

DIGITAL PRESSURE SWITCHES

GS4 Series

Caution: The **GS4** series negative pressure is displayed in -cmHg, while positive pressure is displayed in kgf/cm².

● 1-Point Setting Method

Uses variable hysteresis mode.

● Repeatable Precision

Comparative output ±3% FS max.

● Connector Method

The input/output sector uses the connector, making wiring easy in a short time.



Example of mounting in series

Specifications

Item	Category	Model	Negative pressure			Positive pressure	
			Digital pressure switch		Type 10kgf/cm ²	Type 1kgf/cm ²	
			With piping attachment		With piping attachment	With piping attachment	
			GS410	GS420	GS421		
Rated pressure range			0~-101.3kPa {0~-76cmHg}	0~0.97MPa {0~9.9kgf/cm ² }	0~0.1MPa {0~1.0kgf/cm ² }		
Set pressure range <small>(Note)</small>			0~-76cmHg {0~-101.3kPa}	0~9.9kgf/cm ² {0~0.97MPa}	0~1.0kgf/cm ² {0~0.1MPa}		
Proof pressure			0.5MPa {5.1kgf/cm ² }	1.5MPa {15.3kgf/cm ² }	0.5MPa {5.1kgf/cm ² }		
Media			Air or non-corrosive gas				
Repeatable accuracy (comparative output)			±3% FS max. (display ±2 digits)				
Power supply voltage			DC12~24V ±10% ripple P-P10% max.				
Consumption current			25mA max.				
Output method		Comparative output	NPN transistor open collector ● Output capacity: DC28V, 80mA max. ● Residual voltage: 0.8V max. (at rush current of 80mA)				
		Display	2½ column LCD display (sampling period 2.5 times/second)				
		Operations display lamp	Red LED (lights up when output ON)				
		Temperature range	At a temperature range of 0~+50°C, with detection output of ±3% FS max. at 25°C				
Environmental resistance		Protective configuration	IP40 (IEC144)				
		Anti-noise	240Vp·pulse width 0.5 μs (power supply line radiation)				
		Withstand voltage	AC500V in 1 minute				
		Insulation resistance	100M Ω max. (at DC500 meggers)				
		Anti-vibration	10~55Hz, double amplitude 1.5mm, 2 hours in each X, Y, Z direction				
Material		Shock resistance	196.1m/s ² {20G}, 3 times in each X, Y, Z direction				
		Case	ABS				
		Piping attachment	Aluminium extrusion (anodized)				
	Cable	0.14SQ cabtire cable 3 wick, 1.5m material PVC					
	Mass	55g (including lead wires)					

Note: Display values are for negative pressure in cmHg units and for positive pressure in kgf/cm² units.

Order Codes

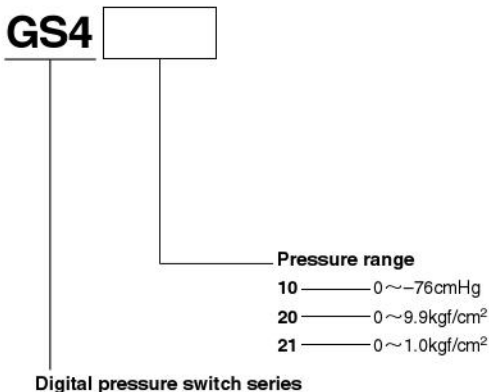

Dimensional Drawings (Scale: 1/1, Unit: mm)

- GS410
- GS420
- GS421

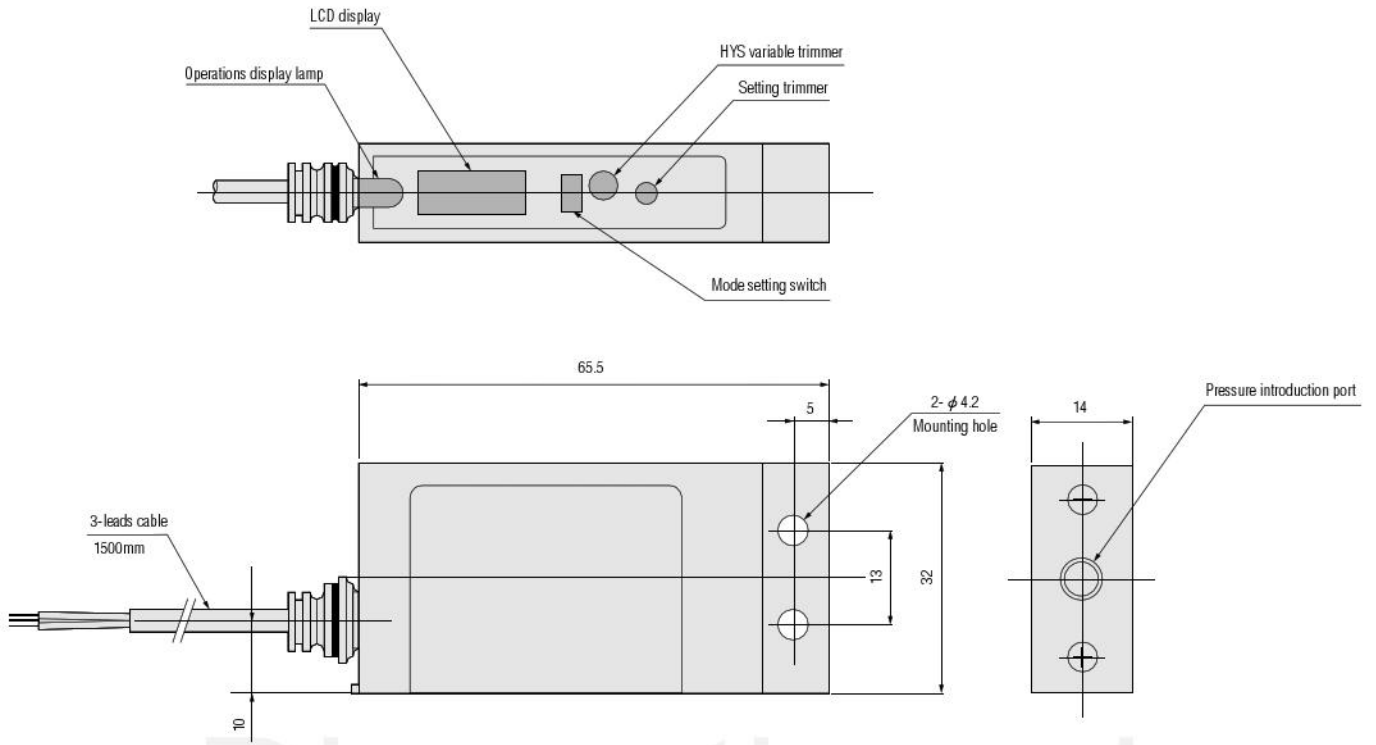

Discontinued

Setting the Operating Pressure

GS4 Series

1) Output mode

The output mode is the 1-point setting hysteresis mode.

- The hysteresis mode setting trimmer (HYS variable trimmer) can be used to change the size of the hysteresis.
- The hysteresis variable range is 0.2~10%FS.

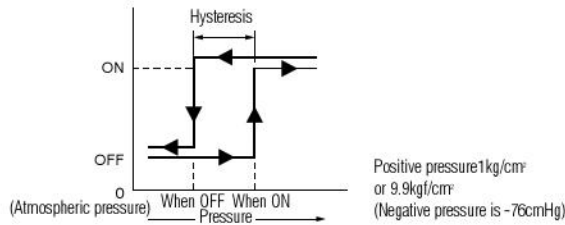

2) Setting method

Display modes include the detection mode and the setting mode, and using the mode change switch allows switching from one mode to another. (The set values are written directly to the EEPROM, and therefore would not be erased when the power supply is turned off.)

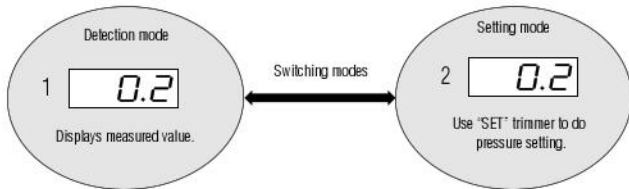
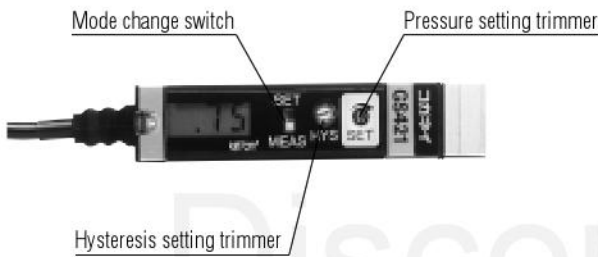

Setting the Hysteresis

Turning the "HYS" trimmer counterclockwise causes the range to become smaller, while turning it clockwise causes the range to become larger.

No.	Setting item	Mode	Setting method																																	
1	Zero-point adjustment	Detection mode	Set the mode setting switch to "MEAS." Confirm that no pressure has been applied. Display value 0 (zero)																																	
2	Level setting	Setting mode	Set the mode setting switch to "SET." Use the "SET" trimmer to set the level. Turning the "SET" trimmer in the counterclockwise direction causes the value to become smaller, while turning it in the clockwise direction causes the value to become larger. <table border="1" style="margin-left: 20px;"> <thead> <tr> <th>Negative pressure</th> <th colspan="2">Positive pressure</th> </tr> <tr> <th>-76cmHg</th> <th>1kgf/cm²</th> <th>10kgf/cm²</th> </tr> </thead> <tbody> <tr> <td>-76</td> <td>1.00</td> <td>10.0</td> </tr> <tr> <td>↑</td> <td>↑</td> <td>↑</td> </tr> <tr> <td>-75</td> <td>.99</td> <td>9.9</td> </tr> <tr> <td>⋮</td> <td>⋮</td> <td>⋮</td> </tr> <tr> <td>⋮</td> <td>⋮</td> <td>⋮</td> </tr> <tr> <td>⋮</td> <td>⋮</td> <td>⋮</td> </tr> <tr> <td>-01</td> <td>.01</td> <td>0.1</td> </tr> <tr> <td>↑</td> <td>↑</td> <td>↑</td> </tr> <tr> <td>-00</td> <td>.00</td> <td>0.0</td> </tr> </tbody> </table>	Negative pressure	Positive pressure		-76cmHg	1kgf/cm ²	10kgf/cm ²	-76	1.00	10.0	↑	↑	↑	-75	.99	9.9	⋮	⋮	⋮	⋮	⋮	⋮	⋮	⋮	⋮	-01	.01	0.1	↑	↑	↑	-00	.00	0.0
Negative pressure	Positive pressure																																			
-76cmHg	1kgf/cm ²	10kgf/cm ²																																		
-76	1.00	10.0																																		
↑	↑	↑																																		
-75	.99	9.9																																		
⋮	⋮	⋮																																		
⋮	⋮	⋮																																		
⋮	⋮	⋮																																		
-01	.01	0.1																																		
↑	↑	↑																																		
-00	.00	0.0																																		
3	—	Detection mode	Set the mode change switch to "MEAS" and complete the setting.																																	

Discontinued

Proper Handling and Precautions

Input/Output Circuit Diagram

GS3 Series/GS4 Series

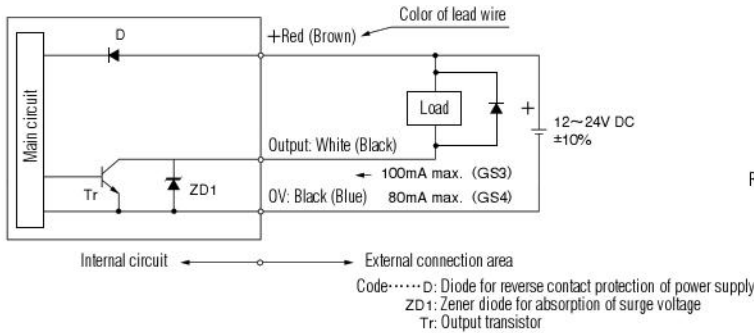

Remark: In 1993, the lead wire colors were changed to the colors shown in parentheses ().

Please Use Correctly

Piping

Since the pressure introduction port is an M5 female thread, screw the fitting into place. In this case, grasp the metallic (aluminium) part of the main body to tighten. The tightening torque should be 98.1N·cm {10kgf·cm} max.

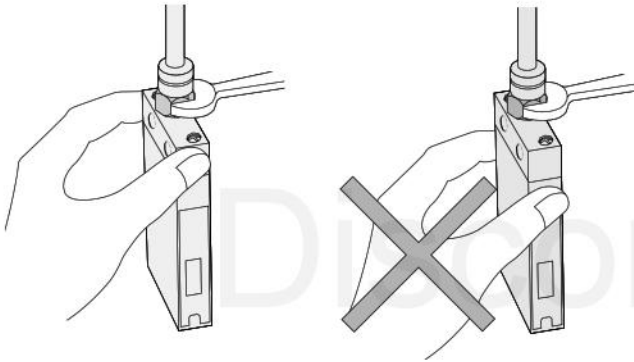

Wiring

Lead connections are as shown in the table below. Be careful not to make mistakes in the wiring.

Also be careful to avoid short circuiting the switch output (white) to the power supply line (red).

Connectors should be adapted as shown below.

Lead connections

Connector No.	Color	Signal
3	Red	V+ (12~24VDC)
4	Black	Common
1	White	Switch output

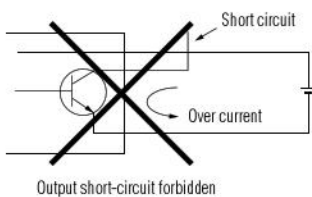

Output short-circuit forbidden

Handling Precautions

1. For the power supply, use a stable DC current. If the power supply line includes such induction loads as relays or solenoids, install a surge voltage absorption circuit. And when using unit power supplies such as switching power supplies, etc., ground it with an FG terminal.

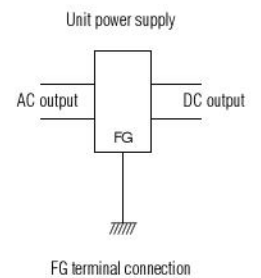

2. Do not let the switch output terminal short-circuit the power supply terminal, or connect a low-resistance load that exceeds the allowable current. Also, install a surge voltage absorption circuit if connecting it to induction loads such as relays or solenoids.

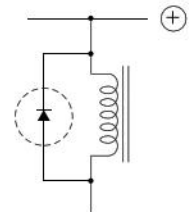

Surge voltage absorption circuit

3. A pressure sensor chip is located inside the pressure introduction port. Never insert wires or other foreign objects into the pressure introduction port, as it could result in a malfunction.



General Precautions

- This product does not have a drip-proof construction. Do not use in locations where it could be exposed to water dripping, etc.
- Applicable media are gases that do not corrode silicon. Do not use liquids or corrosive gases.
- When the main body becomes dirty, wipe down with a rag that has been soaked in a neutral cleaning liquid and then firmly wipe out. Do not use thinner, benzene, etc.

Application Examples

Seating Confirmation (Positive Pressure • Hysteresis Mode)

Application: Machine Tools, Press Machinery, Etc.

Pressure setting can be accurately conducted in 0.1kgf/cm² units.

● Summary

In machining metals, poorly fixed work can lead to degraded machining precision.

Here, low-pressure air supplied from the worktable can be used to check air leaks in the gap between the worktable and the work, to determine whether the work is perfectly seated or not.

● Operating Instructions

As can be seen in the graph at right, the larger the gap, the greater the volume of leakage, and pressure falls. Leakage volume can also be affected by the size of the nozzle diameter.

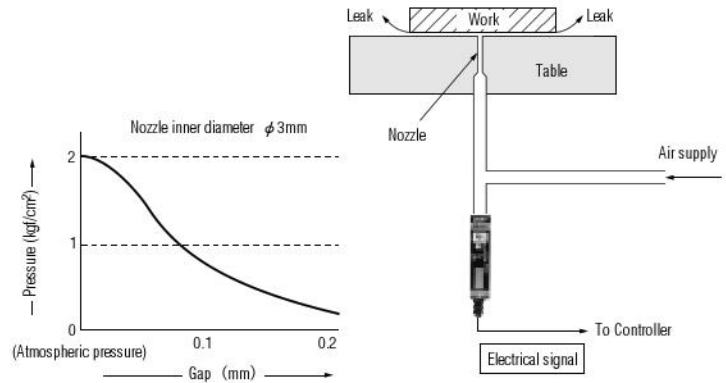

Confirmation of Work Adsorption (Negative Pressure • Hysteresis Mode)

Application: Conveyor Machinery, Semiconductor Manufacturing Equipment, Etc.

● Summary

In a work adsorption conveyor system, a combination of ejectors (vacuum generators) and pressure sensors make an economical air circuit.

● Operating Instructions

The pressure sensor is used to confirm vacuum and air pressure, and to turn the supply of air in the solenoid valve ON or OFF. (Even when the solenoid valve is OFF, the vacuum is maintained until the adsorption is broken.)

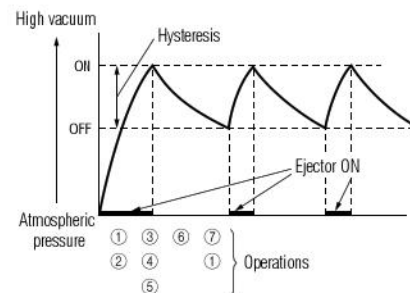
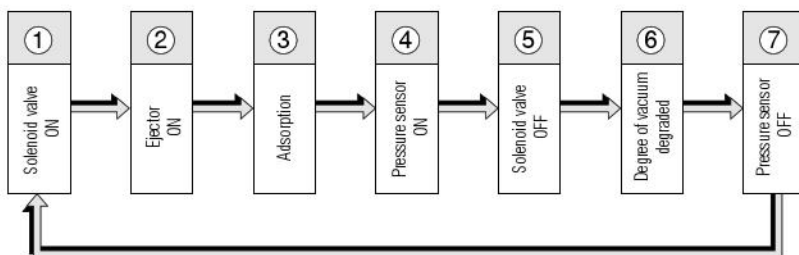
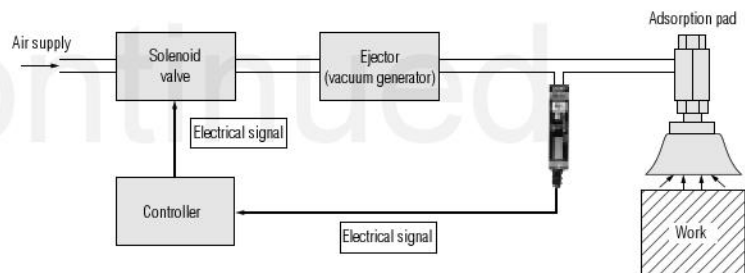

Explanation of Terms

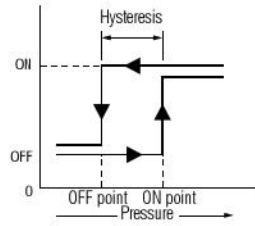
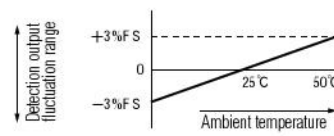
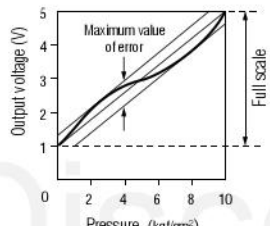
Item	Definition	Item	Definition
Rated pressure range	Pressure range where performance is assured.	Hysteresis	<p>The pressure differential between the comparative output at the ON point and OFF point. Expressed as a percent (%) of the ON point.</p> 
Set pressure range	Operating pressure range where comparative output settings can be made.		
Proof pressure	Maximum pressure at which performance is not degraded when a product is subjected to pressure over the rated pressure range, and then returned to the rated pressure range.		
Repeatable accuracy	<p>The dispersion of pressure values in the ON position, when a product at a certain temperature and a certain voltage is subjected to repeated ON and OFF operations at changing pressures. Expressed as a percent (%) of the full scale.</p> <p style="text-align: center;"> $\frac{\text{Maximum operating point pressure value} - \text{minimum operating point pressure value}}{\text{Rated pressure}}$ </p>	Temperature range	<p>With 25°C as the standard temperature, the range of fluctuation in detection pressure at 25°C, when the ambient temperature changes to the rated temperature, is expressed as a percent (%) of full scale.</p>  <p>This graph is merely a representative example. Trends in characteristics will tend to show some variance between products.</p>
Linearity	<p>While analog output changes nearly linearly in regard to the detection pressure, there is a slight variance from the ideal linearity. This variance is expressed as a percent (%) of the full scale.</p> 		

Pressure Unit Conversion Table

Basic value \ Unit	mmHg	kgf/cm ²	atm	bar	psi	Pa
1mmHg	1	1.3595099×10^{-3}	1.3157895×10^{-3}	1.333224×10^{-3}	1.934×10^{-2}	133.3224
1kgf/cm ²	735.5592	1	0.9678411	0.980665	14.223	98066.5
1atm	760	1.033227	1	1.01325	14.696	101325
1bar	750.0617	1.019716	0.9869233	1	14.504	10 ⁵
1psi	51.715	0.070307	0.0680	0.06895	1	6895
1Pa	7.500617×10^{-3}	1.019716×10^{-5}	9.869233×10^{-6}	10 ⁻⁵	1.45×10^{-4}	1