

DIGITAL PRESSURE SWITCHES

GS3 Series

Caution: **GS3** series negative pressure is displayed in $-cmHg$, while positive pressure is displayed in kgf/cm^2 .

● 2-Point Setting Method

Can select either the hysteresis mode or window comparator mode.

● 2 Types of Connections

Can select from a unit with a piping attachment (M5 screw) or a user-made connection without a piping attachment.

● Repeatability Accuracy

Comparative output $\pm 1\%$ FS max.



Example of mounting in series (Without piping attachment)

Specifications

Item	Category	Negative pressure		Positive pressure			
		Digital pressure switch		10kgf/cm ² type		1kgf/cm ² type	
		Without piping attachment		Without piping attachment		Without piping attachment	
		With piping attachment		With piping attachment		With piping attachment	
Model		GS310N	GS310	GS320N	GS320	GS321N	GS321
Rated pressure range		0~-101.3kPa (0~-76cmHg)		0~0.97MPa (0~9.9kgf/cm ²)		0~0.1MPa (0~1.0kgf/cm ²)	
Set pressure range (Note)		0~-76cmHg (0~-101.3kPa)		0~9.9kgf/cm ² (0~0.97MPa)		0~1.0kgf/cm ² (0~0.1MPa)	
Proof pressure		0.5MPa (5.1kgf/cm ²)		1.5MPa (15.3kgf/cm ²)		0.5MPa (5.1kgf/cm ²)	
Media		Air or non-corrosive gas					
Repeatability accuracy (comparative output)		$\pm 1\%$ FS max. (display ± 1 digit)					
Power supply voltage		DC12~24V $\pm 10\%$ ripple P-P10% max.					
Consumption current		30mA max.					
Output method	Comparative output	NPN transistor open collector ● Output capacity: DC30V,100mA max. ● Residual voltage: 1V max. (at flow current of 100mA)					
	Display	2 1/2 digit LCD display (sampling cycle 4 times/second)					
	Operations display lamp	Red LED (lights up when output is ON)					
	Temperature range	At a temperature range of 0~+50°C, with detection output of $\pm 3\%$ FS max. at 25°C					
Environmental resistance	Protective configuration	IP40 (IEC144)					
	Anti-noise	240Vp • pulse width 0.5 μ s (power supply line radiation)					
	Withstand voltage	AC1000V in 1 minute					
	Insulation resistance	50M Ω max. (at DC500 meggers)					
	Anti-vibration	10~55Hz, double amplitude 1.5mm, 2 hours in each X, Y, Z direction					
Material	Shock resistance	98m/s ² (10G), 3 times in each X, Y, Z direction					
	Case	ABS					
	Piping attachment	Aluminium extrusion (anodized)					
	Cable	0.18SQ cabtire cable 3 wick, 0.5m material PVC					
	Mass	40g (including lead wires; without piping attachment, 30g)					

Note: Display values are for negative pressure in cmHg units, and for positive pressure in kgf/cm² units.

Order Codes

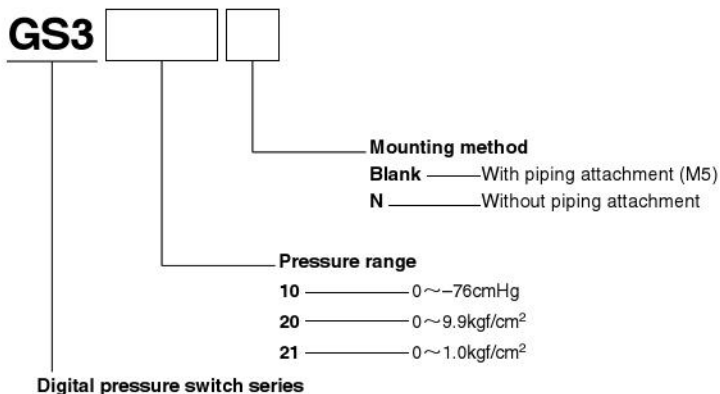

Dimensional Drawings (Scale: 1/1, Unit: mm)

- GS310
- GS320
- GS321

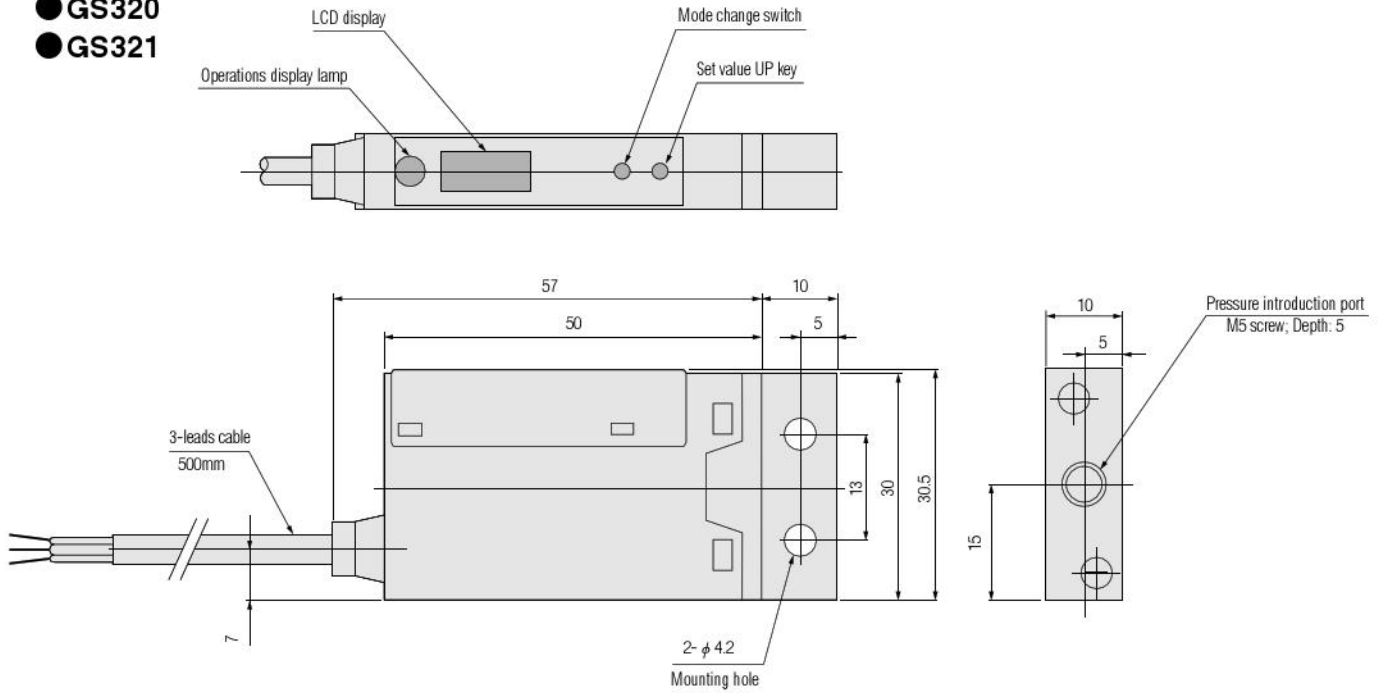

- GS310N
- GS320N
- GS321N

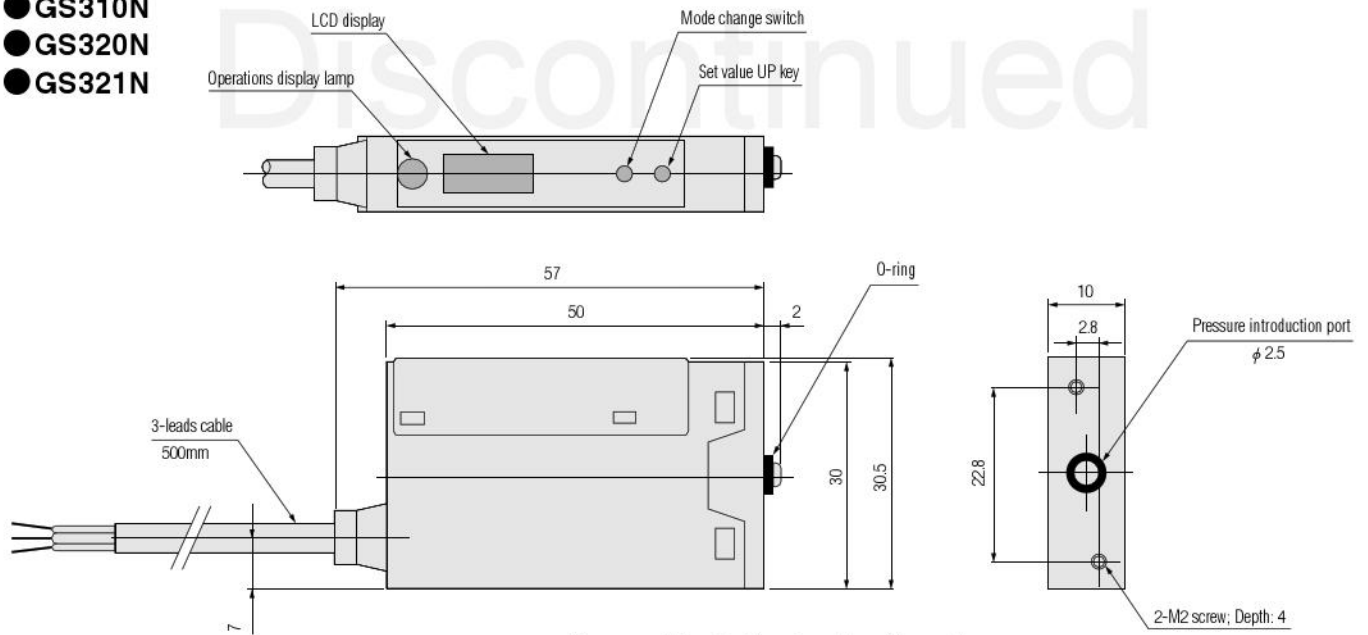

Pressure introduction housing dimensions

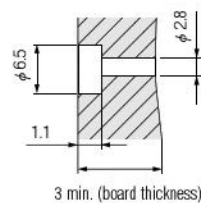

Machine the seal housing dimensions for mounting pressure switches according to the dimensions shown at left. (As it is a sealed surface, it should not be scratched.)

Note: When mounting the switch, be sure to hold the body from the bottom.

Setting the Operating Pressure

GS3 Series

Output operation

M1 and M2 pressure settings allow selection of 2 output modes.

Hysteresis mode (M1 > M2)

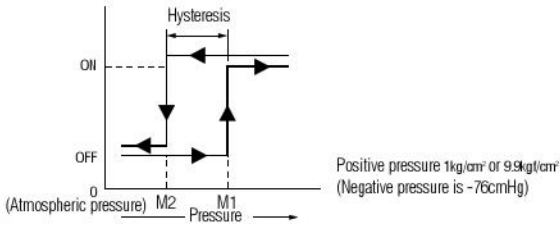

Window comparator mode (M1 < M2)

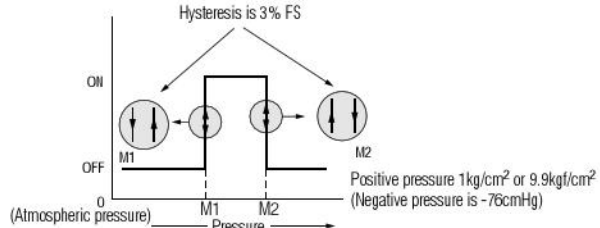

Note: Place a differential of 6%FS min. between M1 and M2. Do not let the M1 and M2 values become identical. This would cause hysteresis to disappear, and create instability in operations.

Operating method

Display modes include the detection mode, zero-point adjustment mode, M1 setting mode and M2 setting mode, and pressing the mode switch can change from one mode to another. (The set values are written directly to the EEPROM, and therefore would not be erased when the power supply is turned off.)



LCD display pattern

- Lights up when in "zero-point adjust" mode
- Lights up when in "M1 setting" mode
- Lights up when in "M2 setting" mode

Extension diagram

At negative pressure, registers as "--"

No.	Mode	LCD display	Setting method																								
1	Zero-point adjustment mode (0-ADJ)	"Zero-point adjustment" DOT lights up. Pressure measurement value light flashes ON and OFF.	Return the applied pressure to atmospheric pressure level, and press the set value UP key to make zero-point adjustment. After adjustment is completed, the light changes from flashing to lighted. If pressure is applied during zero-point adjustment, message E3 is displayed.																								
2	M1 setting mode	"M1 setting" DOT lights up. Displays the last time M1 setting value was set.	Use the setting "UP" key to set the M1. Pressing the "UP" key raises the value. It will speed up if pressing is continued for about 2.5S (5 counts) min. Resets to 0 if setting range is exceeded. <table border="1"> <tr> <th>Negative pressure</th> <th colspan="2">Positive pressure</th> </tr> <tr> <td>-76cmHg</td> <td>1kg/cm²</td> <td>10kg/cm²</td> </tr> <tr> <td>↑</td> <td>↑</td> <td>↑</td> </tr> <tr> <td>-75</td> <td>99</td> <td>9.9</td> </tr> <tr> <td>⋮</td> <td>⋮</td> <td>⋮</td> </tr> <tr> <td>-01</td> <td>.01</td> <td>0.1</td> </tr> <tr> <td>↑</td> <td>↑</td> <td>↑</td> </tr> <tr> <td>-00</td> <td>.00</td> <td>0.0</td> </tr> </table>	Negative pressure	Positive pressure		-76cmHg	1kg/cm²	10kg/cm²	↑	↑	↑	-75	99	9.9	⋮	⋮	⋮	-01	.01	0.1	↑	↑	↑	-00	.00	0.0
Negative pressure	Positive pressure																										
-76cmHg	1kg/cm²	10kg/cm²																									
↑	↑	↑																									
-75	99	9.9																									
⋮	⋮	⋮																									
-01	.01	0.1																									
↑	↑	↑																									
-00	.00	0.0																									
3	M2 setting mode	"M2 setting" DOT lights up. Displays the last time the M2 setting value was set.	In the same way as the M1 level settings, use the setting "UP" key to set the M2.																								
4	Detection mode	All setting display DOT lights turn OFF. Displays the pressure measurement value.	Press the mode change switch to complete the setting.																								

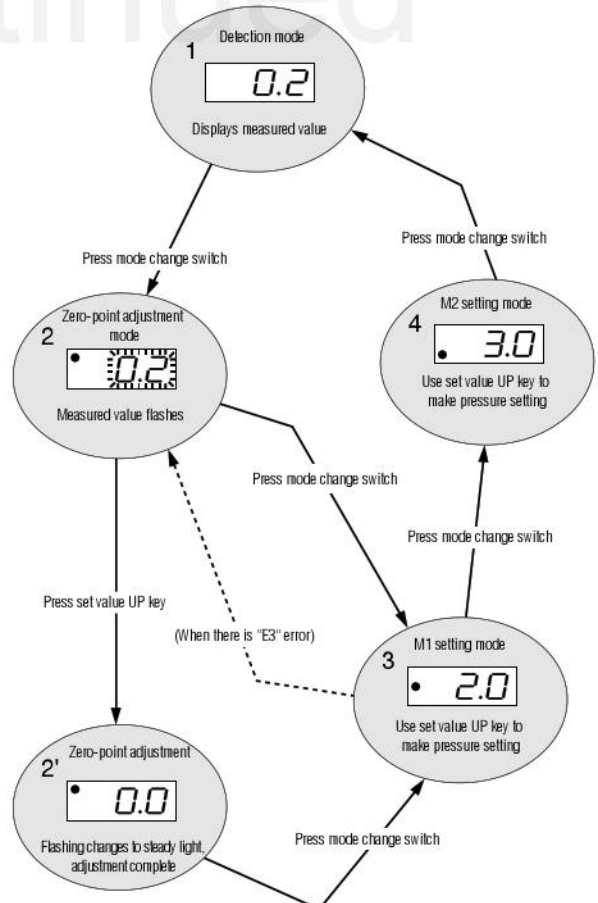

Remark: Output retains the situation during setting operation when the mode change switch was first pressed.

☆ When an error occurs, take the following measures:

Error display	Content	Measures
E1	Load has short-circuited, and eddy current is flowing.	Turn off the power supply and confirm the load.
E2	M1 and M2 setting values in the window comparator mode are smaller than about 6% FS.	Return the value to about 6% FS min., and set again.
E3	Pressure is applied during zero-point adjustment.	Return the applied pressure to atmospheric pressure level, and then make the zero-point adjustment again.
--	Applied pressure surpasses rated pressure range.	Return the applied pressure to within the rated pressure range.