

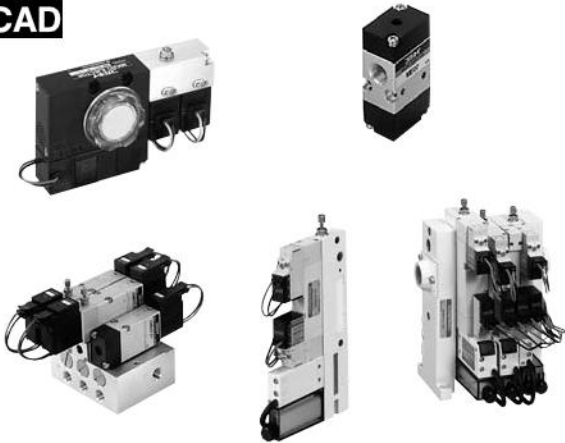

CAD drawing data catalog is available.



KOGANEI

ACCESSORIES GENERAL CATALOG

AIR TREATMENT, AUXILIARY, VACUUM,
AND FLUORORESIN PRODUCTS

MICRO EJECTORS CONTENTS

GME05, GME07, GME10 Series	
Features	679
Specifications	680
Order Codes	682
Operation Principle and Major Parts	683
Symbols	685
Dimensions	686
Handling Instructions and Precautions	689
Air Consumption, Vacuum and Vacuum Flow Rate	692
ME03, ME05, ME07 Series	
Specifications	693
Order Codes	694
Operation Principle and Major Parts	695
Symbols, Mass	696
Dimensions of ME03	697
Dimensions of ME05	698
Dimensions of ME07	700
Dimensions of Electronic Vacuum Switch	702
Handling Instructions and Precautions	703
ME12, ME25, ME60 Series	
Specifications	706
Order Codes, Operation Principle and Major Parts	707
Air Consumption, Vacuum and Vacuum Flow Rate	708
Dimensions of ME12	709
Dimensions of ME25, ME60	710
Handling Instructions and Precautions	711
Time to Reach Vacuum and Vacuum Breaking Time	712



Caution

Before use, be sure to read the "Safety Precautions" on p. 49.

MICRO EJECTORS GME Series

Thin, lightweight and compact.

Downsizing

- The diffuser and ejector body are integrated into a single compact and lightweight plastic unit that is completely downsized.
- Product line-up includes the high response type GME05 and the low wattage type (power consumption 0.5W) GME07 and GME10.
- Can be mounted on the tool plate section of orthogonal robots, etc., which shortens the tubes connecting to vacuum pads to obtain high response.

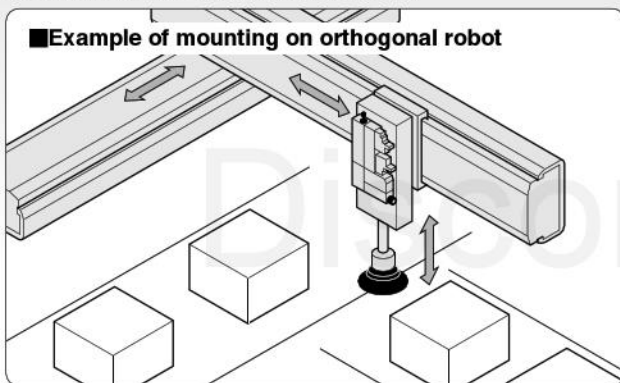

- Combined mounting manifolds of GME05, GME07, and GME10 enable the user to select combinations suitable for each workpiece requirement.
- Manifold types are provided with six types of end blocks to increase the selection of exhaust direction flexibility.
- Individual exhausts for single-unit use are also available as an option.

■ Separate exhaust fitting block

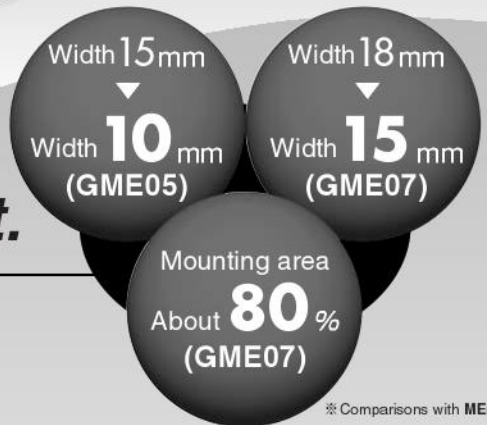
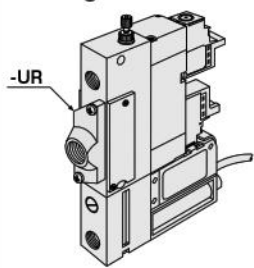

Three series of two types each to match your application needs!

High Response Type

GME05-□ (for single unit)

GAME05-□ (for manifold)

- Nozzle diameter : 0.5mm [0.020in.]
- Vacuum flow rate * : 5.5 ℓ /min [0.194ft³/min.] (ANR)
- Vacuum * : -86.7kPa [-25.6in.Hg]
- Power consumption : 3.2/1.1W (starting/holding)



Low Wattage Type (DC specifications)

GME07-□ (for single unit)

GAME07-□ (for manifold)

- Nozzle diameter : 0.7mm [0.028in.]
- Vacuum flow rate * : 11 ℓ /min [0.39ft³/min.] (ANR)
- Vacuum * : -86.7kPa [-25.6in.Hg]
- Power consumption : 0.5W (DC5~24V)



GME10-□ (for single unit)

GAME10-□ (for manifold)

- Nozzle diameter : 1.0mm [0.039in.]
- Vacuum flow rate * : 22 ℓ /min [0.78ft³/min.] (ANR)
- Vacuum * : -86.7kPa [-25.6in.Hg]
- Power consumption : 0.5W (DC5~24V)



※ Value (approximate) at pressure of 0.5MPa [73psi].

MICRO EJECTORS

GME05, GME07, GME10



Specifications

Basic model		GME05-E1/GAME05-E1 GME05-E2/GAME05-E2	GME07-E1/GAME07-E1 GME07-E2/GAME07-E2	GME10-E1/GAME10-E1 GME10-E2/GAME10-E2	
Media		Air ^{Note2}			
Operating pressure range	MPa [psi.]	0.1~0.6 [15~87]	0.2~0.6 [29~87]		
Proof pressure	MPa [psi.]	0.9 [131]			
Operating temperature range (atmosphere and media) ^{Note3}		5~50 [41~122]			
Nozzle diameter	mm [in.]	0.5 [0.020]	0.7 [0.028]	1.0 [0.039]	
Vacuum ^{Note1}	kPa [in.Hg]	-86.7 [-25.6]			
Vacuum flow rate ^{Note1}	ℓ/min [ft. ³ /min.] (ANR)	5.5 [0.194]	11 [0.39]	22 [0.78]	
Compressed air consumption ^{Note1}	ℓ/min [ft. ³ /min.] (ANR)	11 [0.39]	23 [0.81]	46 [1.62]	
Lubrication		Prohibited			
Filtration		30			
Port size	Vacuum generation port	M5×0.8	Rc1/8		
	Compressed air supply port ^{Note4}	M5×0.8	Rc1/8		
Mounting direction		Any			
Main valve specifications	Response time ^{Note5}	A/B ms	6.5/8.5	18/15.5	
	Operation method		Direct operating	Indirect operating	
	Number of positions, number of ports		2 positions, 2 ports		
	Valve function		Normally closed (NC standard)		
	Effective area	mm ² [Cv]	0.6 [0.03]	2.3 [0.13]	4.5 [0.25]
Shock resistance ^{Note6}		m/s ² [G]	1373 [140] (196 [20])		

- Notes: 1. Value (approximate) at pressure of 0.5MPa [73psi].
 2. Assumes use of pure air from which oil mist and dust, etc., have been removed.
 3. Take heat radiation measures to ensure that the ambient temperature (or when used in a control box, the inside temperature of the box) always remains within the specified temperature range. Moreover, for long-term continuous operation, consult us.
 4. **GAME** □ is blocked with a plug.
 5. The period from when a solenoid valve for controlling air is energized until generation of negative pressure is A, while the period from when a solenoid valve for controlling vacuum breaking air is energized until a generation of vacuum breaking is B.
 6. Figures in parentheses () are shock resistance values in the valve stem axis direction. The shock resistance values are the values where breaking of vacuum holding occurs.

Solenoid Specifications

Mounting solenoid valve models		GA010LE1, GAV010LE1-11				GA010HE1		GA010E1	
Rated voltage		DC5V	DC6V	DC12V	DC24V	DC12V	DC24V	AC100V	AC200V
Operating voltage range	V	4.5~5.5 (5±10%)	5.4~6.6 (6±10%)	10.8~13.2 (12±10%)	21.6~26.4 (24±10%)	10.8~13.2 (12±10%)	21.6~26.4 (24±10%)	90~110 (100±10%)	180~220 (200±10%)
Rated frequency	Hz	—	—	—	—	—	—	50	60
Current (when applied rated voltage)	mA(r·m·s)	100	84	42	21	—	—	11	8
Power consumption		0.5W				—	—	1.1VA	1.6VA
Allowable circuit leakage current	mA	1.0				10	5	1.0	
Current (when applied rated voltage), starting/holding	m·A	—	—	—	—	267/92	133/46	—	—
Power consumption, starting/holding	W	—	—	—	—	3.2/1.1		—	—
Period of starting conditions	m·s	—	—	—	—	48	27	—	—
Insulation resistance	MΩ	100 or more							
Wiring and lead wire length		Grommet type : 300mm [11.8in.], plug connector type : 300mm [11.8in.]							
Color of lead wire		Red (+), Black (-)						Yellow	White
Color of LED indicator		Red							
Surge suppression (standard)		Flywheel diode						Bridge diode	

Mounting solenoid valve

Model	Voltage	Mounting solenoid valve	
GME05	DC	E1	GA010HE1
		E2	GA010HE1, GAV010LE1-11*
GME07	AC	GA010E1	
GME10	DC	GA010LE1	

*: Solenoid valve for vacuum breaking.

Electronic Vacuum Switch Specifications

Model Classification		GME-05E, GME-07E, GME-10E	GME-05EA, GME-07EA, GME-10EA	
Item		Switch 2-output (fixed hysteresis)	Switch 1-output (variable hysteresis) with analog output	
General	Pressure range	0~100kPa [0~29.54in.Hg]	0~100kPa [0~29.54in.Hg]	
	Maximum pressure	200kPa [29psi.]	200kPa [29psi.]	
	Operating temperature	-20~70°C [-4~158°F]		
	Operating ambient humidity	35~85%RH		
	Media	Air or non-corrosive gas		
	Insulation resistance	100MΩ MIN. (at DC500V megger)		
	Cable	Shielded 4 leads×1500mm [59in.] (total length)		
Power supply	Power supply	DC10.8~30V (including ripple)		
	Consumption current	25mA or less <small>Note 1</small>	17mA or less <small>Note 1</small>	
	Number of outputs	2	1	
Switch output	Output type	NPN open collector		
	Pressure setting method	Variable with use of a trimmer		
	Pressure setting range	0~100% of rated vacuum		
	Output display	When ON, operation indication lamp (LED) lights up		
	Accuracy	Within ±3% F.S. <small>Note 2</small>		
	Hysteresis	Within 2% F.S. (fixed)	1~15% variable of the specified value (reference value)	
	Switch capacity	DC30V, 80mA MAX.		
Analog output	Output voltage	1~5V		
	Zero-point voltage (V ^{ZERO})	1±0.1V		
	Span voltage (V ^{SPAN})	4±0.1V		
	Temperature characteristics	V ^{ZERO}	±0.1% F.S./°C [±0.056% F.S./°F] <small>Note 2</small>	
		V ^{SPAN}	±0.1% F.S./°C [±0.056% F.S./°F] <small>Note 2</small>	
	Output current	MAX. 1mA <small>Note 3</small>		
	Linearity/hysteresis	±0.5% F.S. MAX.		
Environmental characteristics	Vibration resistance	98.1m/s ² [10G]		
	Shock resistance	490m/s ² [50G] (non-repeated shock)		

Notes: 1. At power supply of DC24V, and output ON.
 2. 0~50°C [32~122°F], reference point of 25°C [77°F].
 3. Load resistance: 5kΩ or more.

Remark: Unless otherwise specified, ambient temperature is stipulated at 25±5°C [77±9°F], and power supply is DC12V.

Discontinued

Port Size

Basic models		Port size		
		Vacuum generation port	Compressed air supply port	Port exhaust (optional)
Micro ejector	GME05-E1, GME05-E2	M5×0.8	M5×0.8	M6×1
	GME07-E1, GME07-E2	Rc1/8	Rc1/8	Rc1/8
	GME10-E1, GME10-E2			Rc1/4
Manifold	GMEM□A (05 series)	M5×0.8	Rc1/8	Rc3/8 (or muffler)
	GMEM□A (07, 10 series)	Rc1/8		
	Piping connection position	Ejector	Manifold	

Mass

Basic models	Body mass		Additional mass							
	-E1	-E2	Vacuum switch	Exhaust block	Manifold end block					
			-E, -EA	-UR	-ER	-EL	-ED	-KR	-KL	-KD
GME05	153 [5.40]	167 [5.89]	45 [1.59]	14 [0.49]	276 [9.74]	276 [9.74]	274 [9.66]	308 [10.9]	308 [10.9]	338 [11.9]
GME07	207 [7.30]	221 [7.80]	50 [1.76]	17 [0.60]						
GME10	249 [8.78]	263 [9.28]	50 [1.76]	19 [0.67]						

Calculation example **GMEM5A-ER** stn.1~2 **GAME05E2-E-DC24V**
 stn.3~4 **GAME07E2-E-DC24V**
 stn.5 **GAME10E2-E-DC24V**
 $276 + (167 + 45) \times 2 + (221 + 50) \times 2 + 263 + 50 = 1555 [54.85]$

Ejector with Solenoid Valve Order Codes

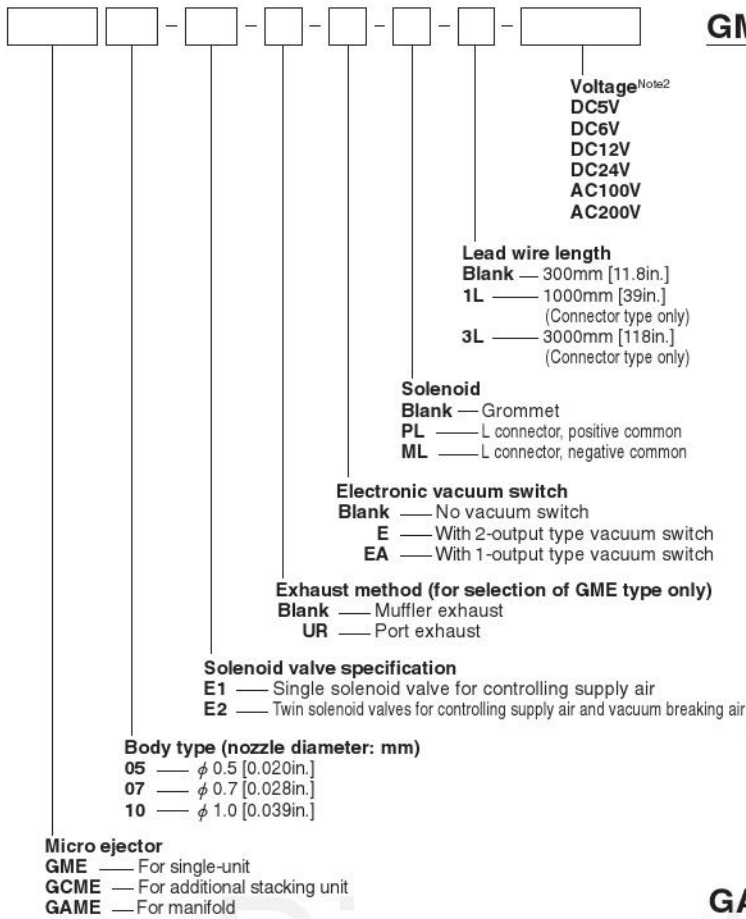

- Notes: 1. Since manifolds of six or more units require a special modification, consult us for delivery times and prices.
 2. Voltage for the GME05 series is limited to DC12V and DC24V. As the mounted solenoid valves vary according to the series, see the table below, and confirm it against the solenoid specifications on p.680.

Model	Voltage	Mounting solenoid valve
GME05	DC	E1 GA010HE1
		E2 GA010HE1, GAV010LE1-11*
GME07	AC	GA010E1
GME10	DC	GA010LE1

* Solenoid valve for controlling vacuum breaking air.

Electronic Vacuum Switch Order Codes

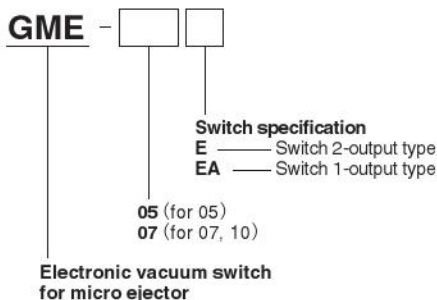

Manifold Order Codes

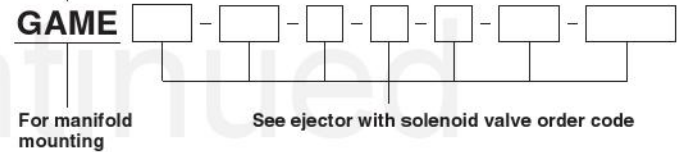
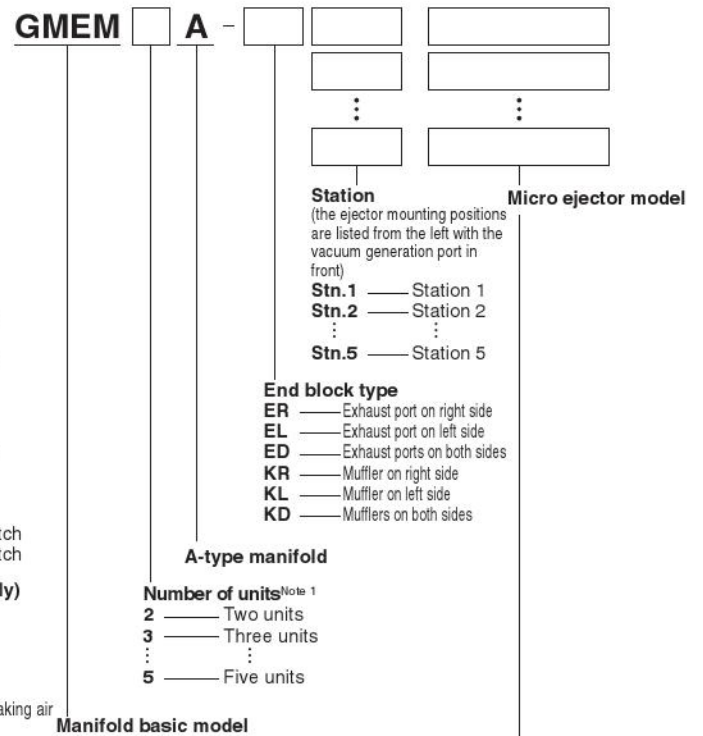

Additional Stacking Unit Order Codes

(for adding one unit when using manifolds)

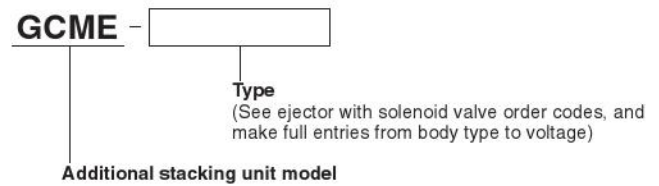

In addition to one manifold use ejector (GCME...), the additional stacking unit includes two stacking rods, one gasket, and one O-ring.

Replacement Filter Order Codes (element only)



Mounting Base Order Code (for direct piping type)

GME-21 (Supplied items: one base, two spacers, two hexagon socket screws)

Muffler Order Codes (only for manifolds)

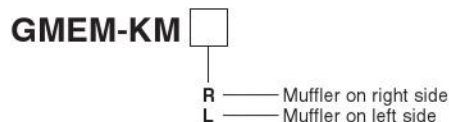

Operation Principle and Major Parts

GME05-E2

● De-energized

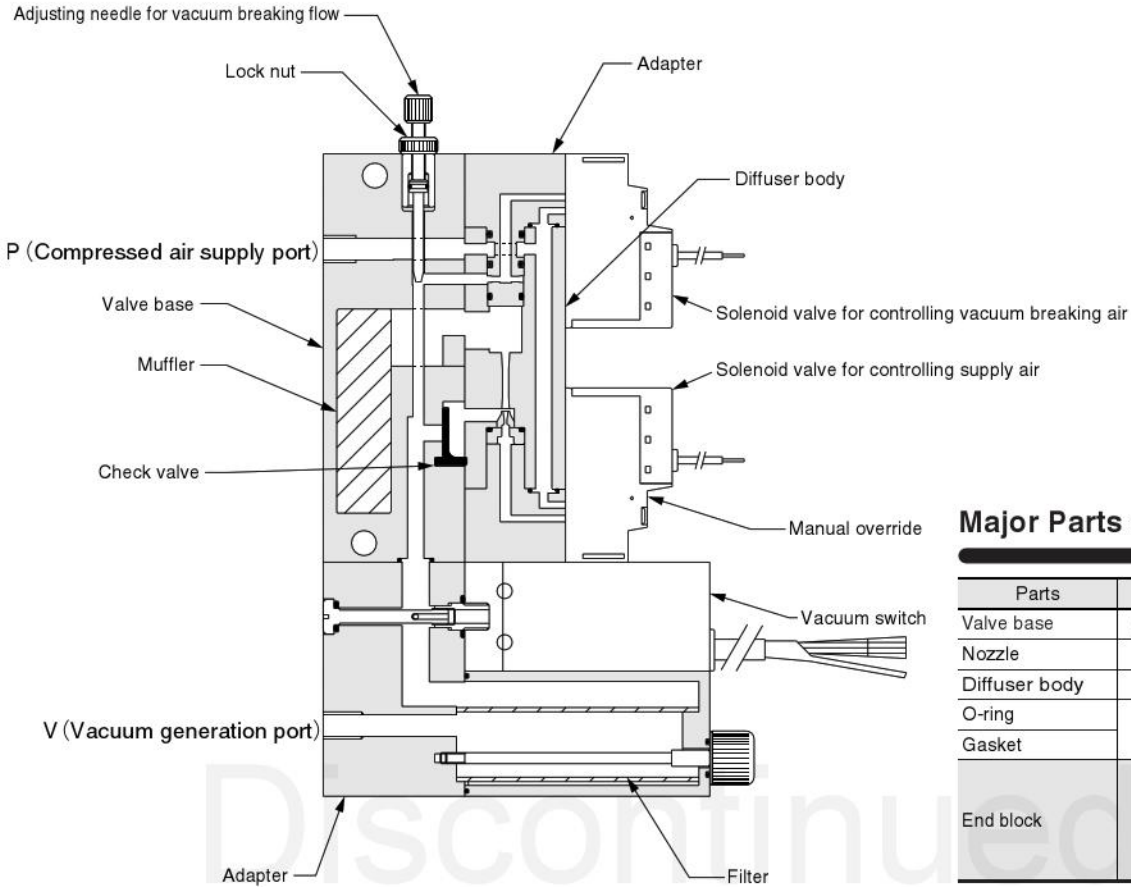

Major Parts and Materials

Parts	Materials
Valve base	Aluminum alloy (painted) and plastic
Nozzle	Brass
Diffuser body	Plastic
O-ring	Synthetic rubber
Gasket	
End block	Aluminum alloy (painted)

● When energizing a solenoid valve for controlling supply air (generating vacuum)

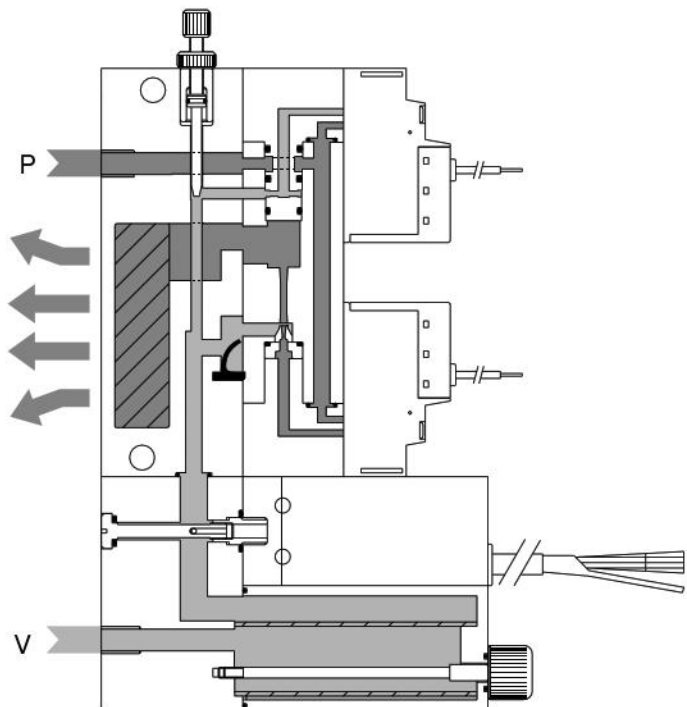

● When energizing a solenoid valve for controlling vacuum breaking air

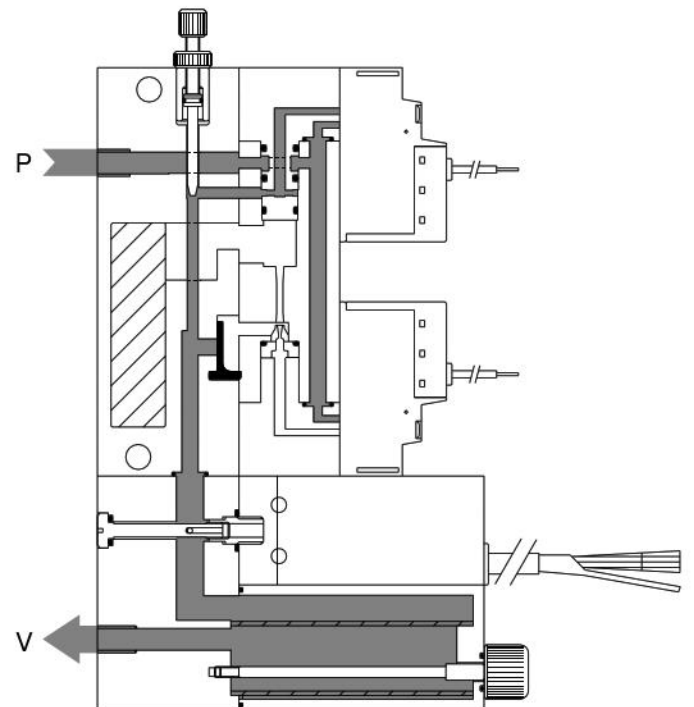

Operation Principle and Major Parts

GME07-E2

GME10-E2

● De-energized

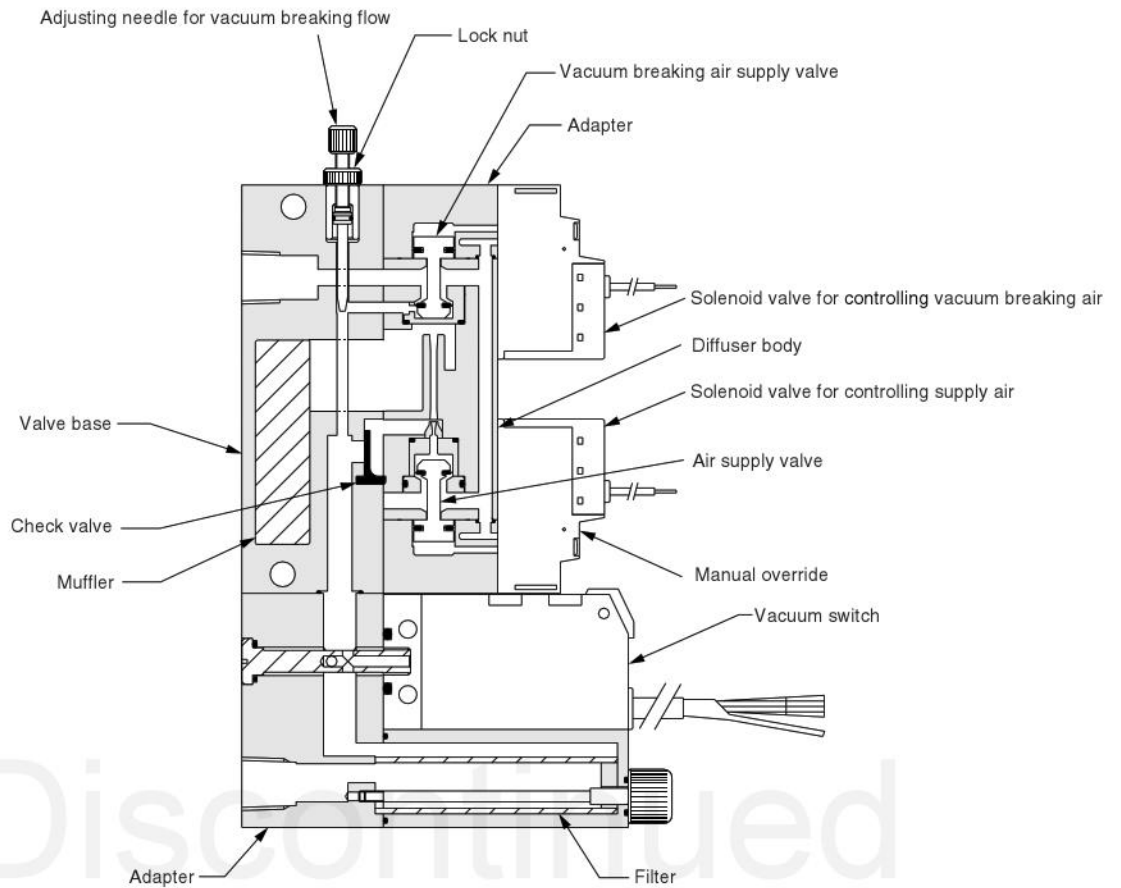

● When energizing a solenoid valve for controlling supply air (generating vacuum)

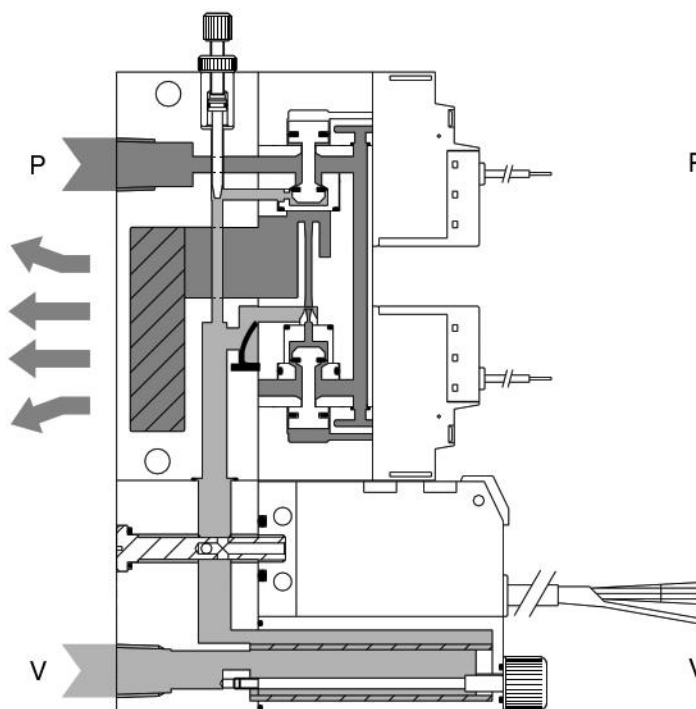

● When energizing a solenoid valve for controlling vacuum breaking air

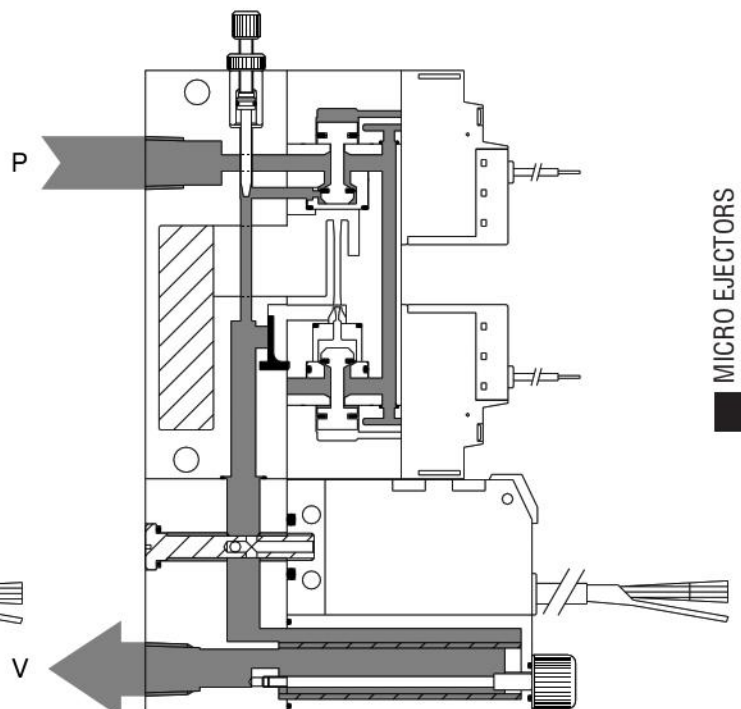

MICRO EJECTORS

Symbols

With single solenoid valve

● GME05-E1

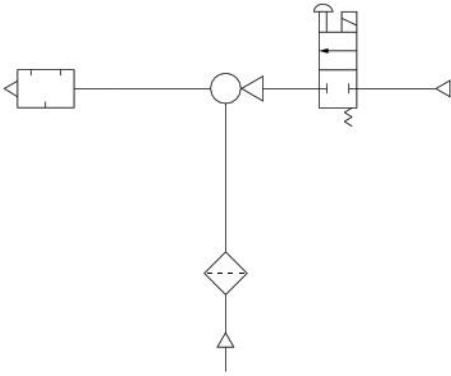

● GME07-E1 ● GME10-E1

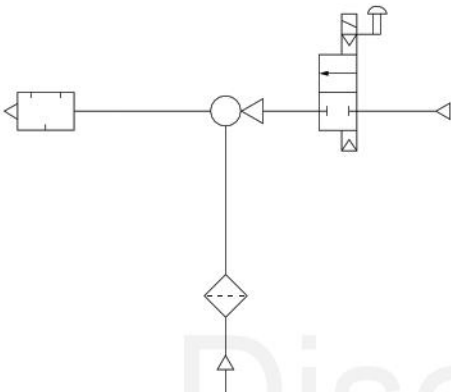

With single solenoid valve and vacuum switch

● GME05-E1-E

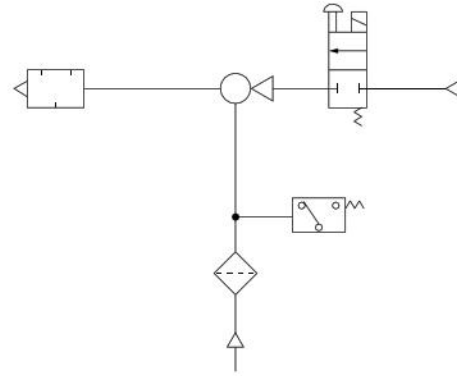

● GME07-E1-E ● GME10-E1-E

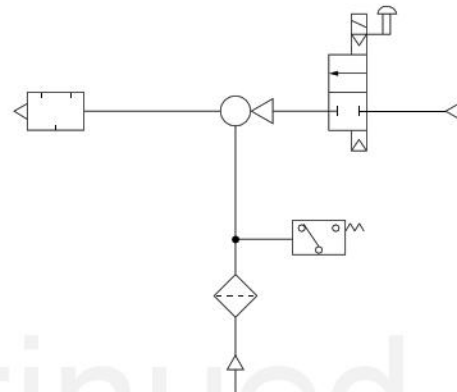

Discontinued

With twin solenoid valves

● GME05-E2

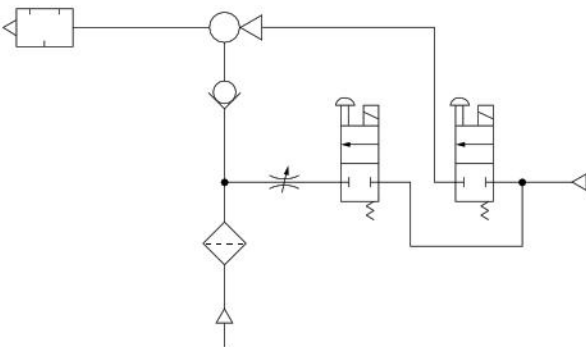

● GME07-E2 ● GME10-E2

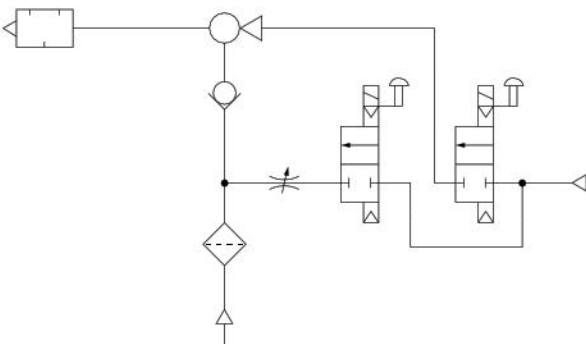

With twin solenoid valves and vacuum switch

● GME05-E2-E

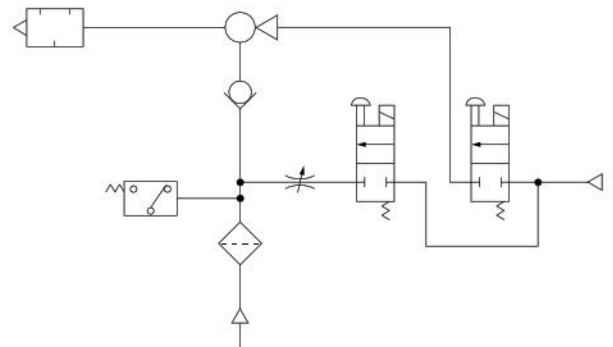

● GME07-E2-E ● GME10-E2-E

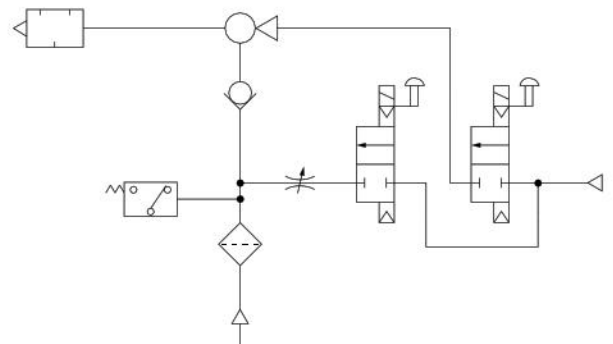

● GME□-E1,E2

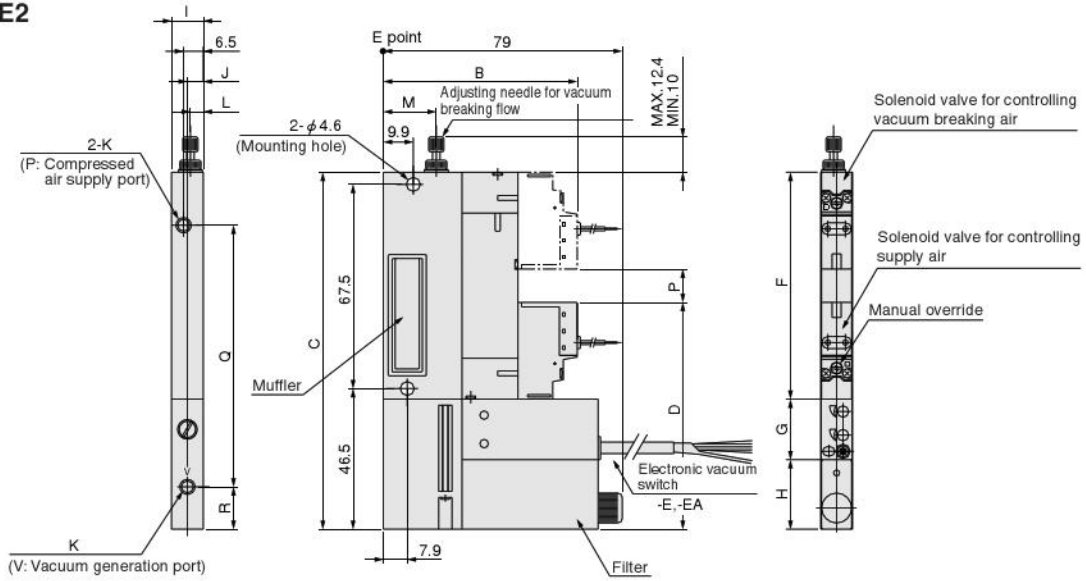

Model	B	C	D	F	G	H	I	J	K	L	M	P	Q	R
GME05-E□	64.1	118	75	75	20	23	10.5	5.25	M5×0.8	4.25	17.5	11	87.5	13
GME07-E□	67.0	118	75	75	25	18	15.5	7.75	Rc1/8	5.75	18.5	11	93.0	8
GME10-E□	67.0	128	75	85	25	18	18.5	9.25	Rc1/8	9.25	18.5	21	95.0	8

Options

● -PL,-ML

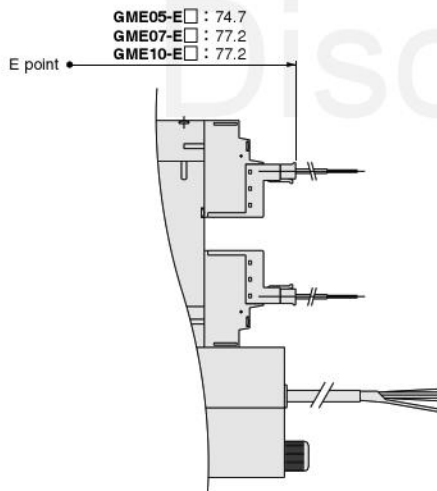

● -21

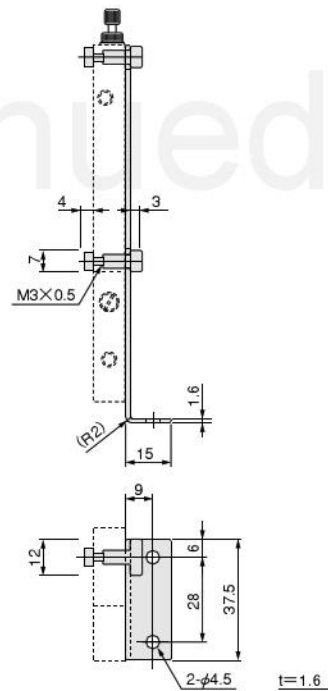

● -UR

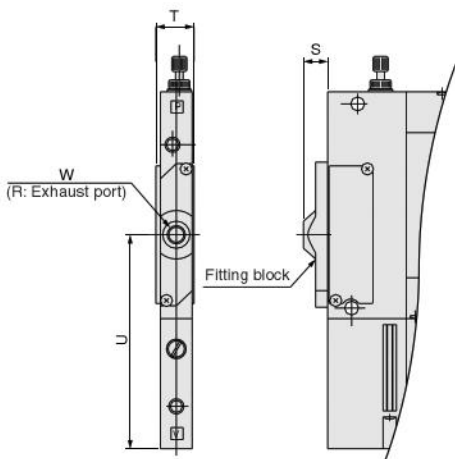

Model	S	T	U	W
GME05-E□	8	15	70.8	M6×1
GME07-E□	10	20	70.8	Rc1/8
GME10-E□	10	23	70.8	Rc1/4

Dimensions (mm)

● GMEM A-ER

Drawings show examples of combined mounting of **GAME05, 07, 10**. For detailed dimensions of each mounted ejector, see p.686.



4-R2.25
Counterbore ϕ 8
depth 4.4 (mounting hole)

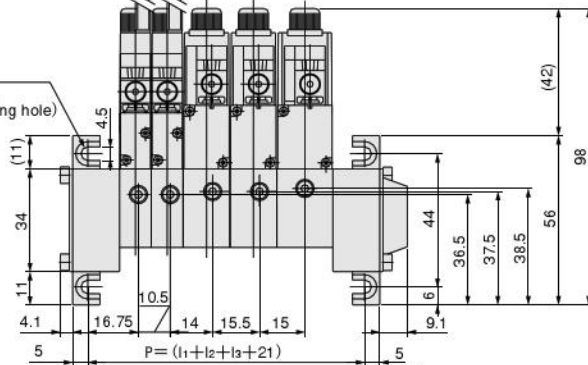

Example diagram GMEM5A-ER

- stn. 1~2 **GAME05-E2-E...**
- stn. 3~4 **GAME07-E2-E...**
- stn. 5 **GAME10-E2-E...**

L dimension calculation methods

$$L = (l_1 + l_2 + l_3 + 31)$$

$$L = 22 + 32 + 19 + 31$$

$$L = 104$$

Number of units	l ₁ (GME05)	l ₂ (GME07)	l ₃ (GME10)
1	11	16	19
2	22	32	38
3	33	48	57
4	44	64	76
5	55	80	95

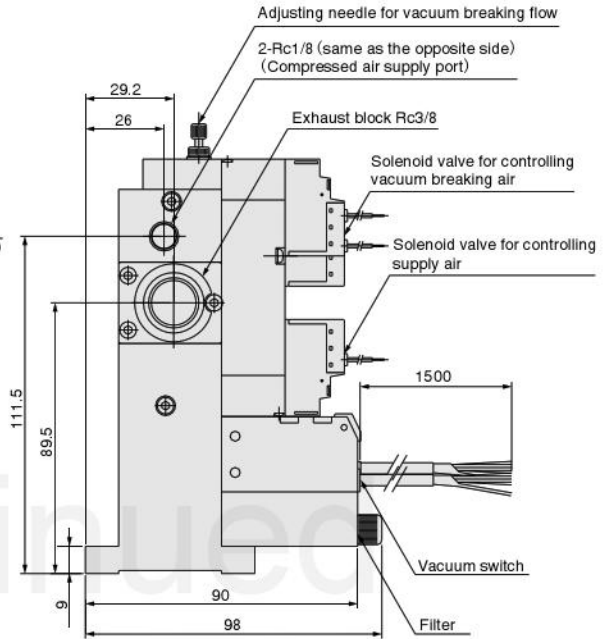
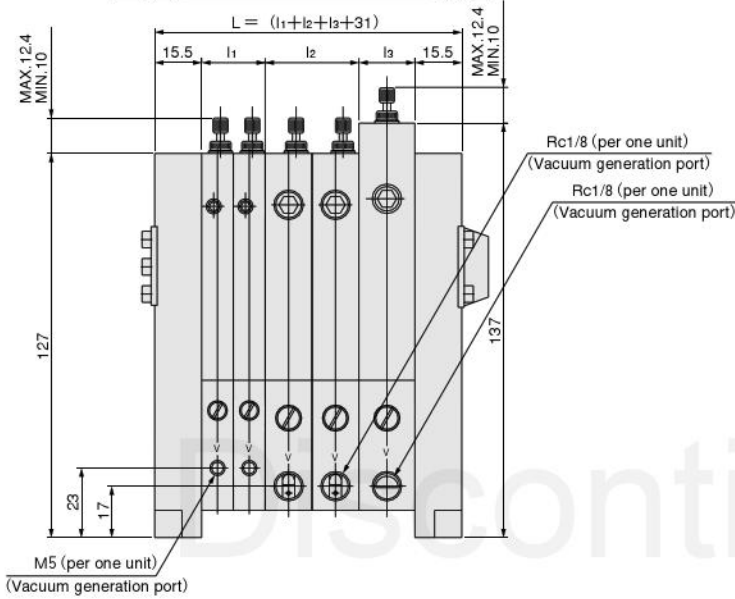

● -EL

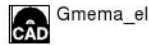

4-R2.25
Counterbore ϕ 8
depth 4.4 (mounting hole)

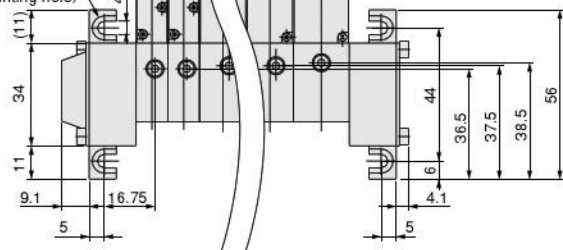

● -ED

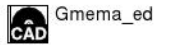

4-R2.25
Counterbore ϕ 8
depth 4.4 (mounting hole)

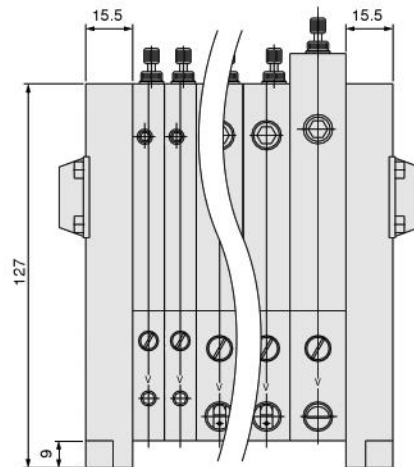
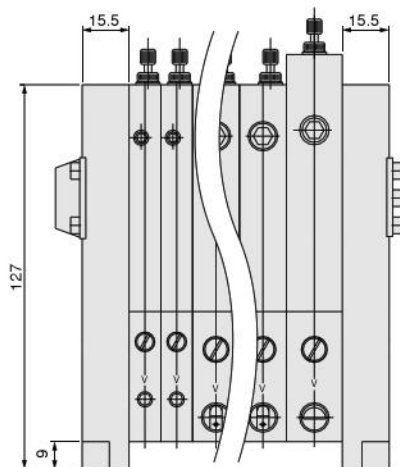
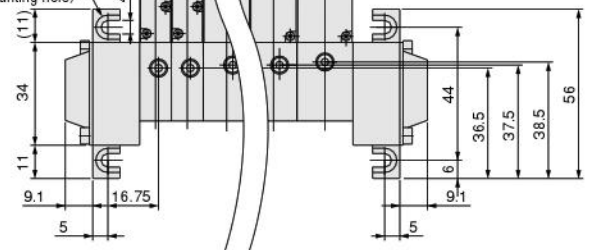

Dimensions (mm)

●-KL

CAD Gmema_kl

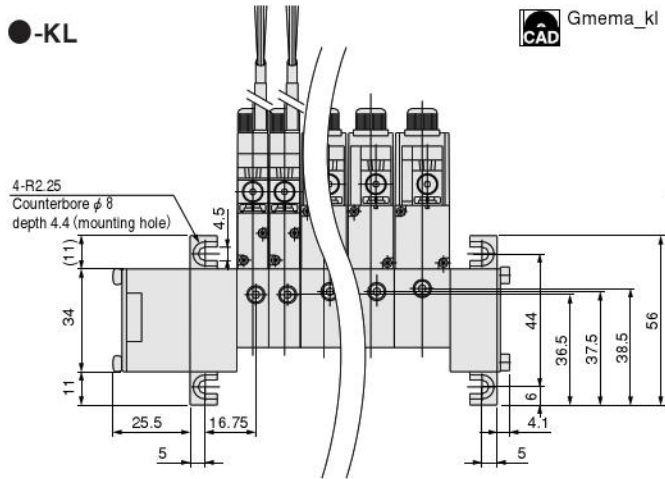

●-KR

CAD Gmema_kr

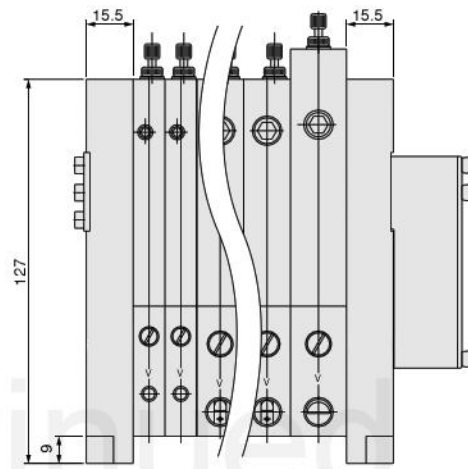
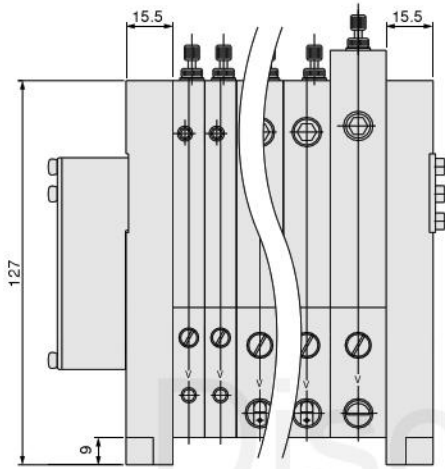
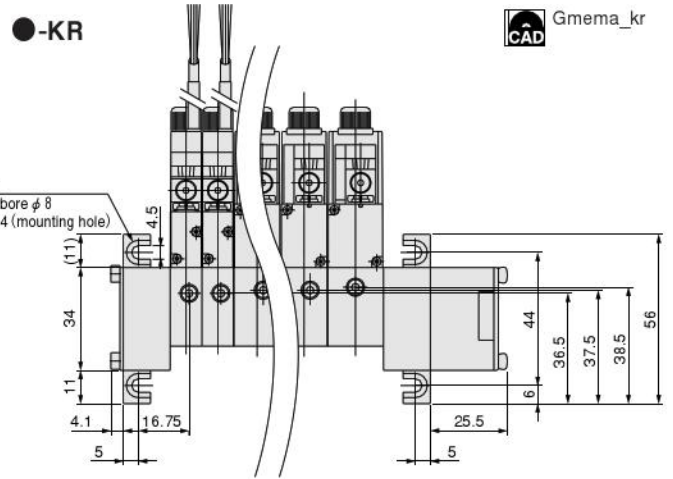

●-KD

CAD Gmema_kd

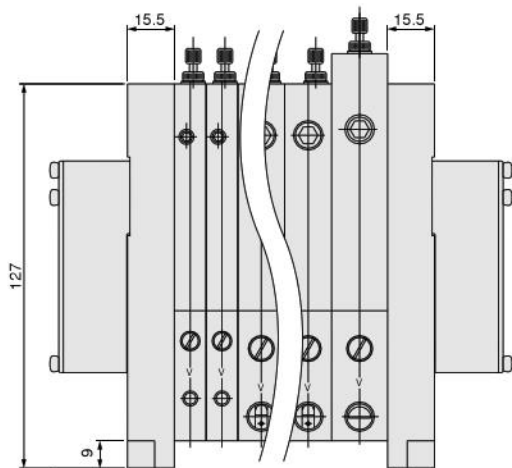
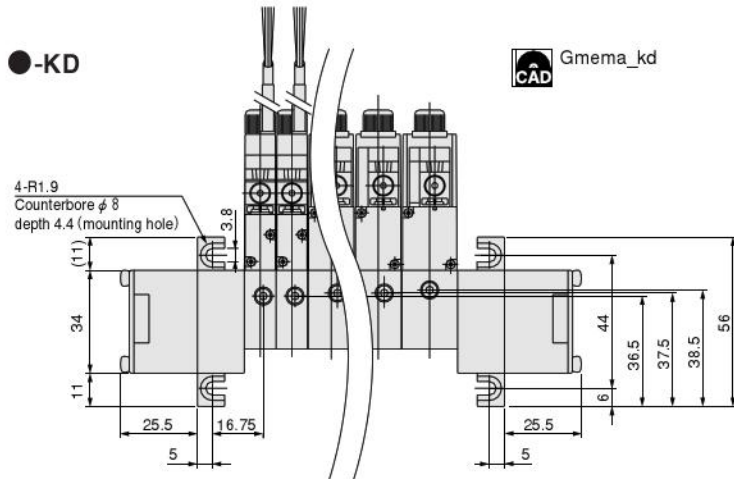



Solenoid

Internal circuit

- DC5V, DC6V, DC12V, DC24V (GA010LE1, GAV010LE1-11)

Solenoid with LED indicator (surge suppression)

- Positive common

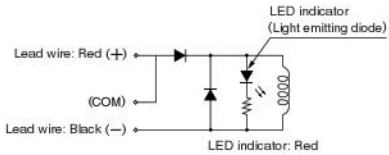

- Negative common (made to order)

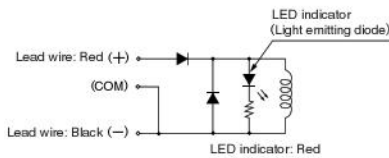

- DC12V, DC24V (GA010HE1)

Solenoid with LED Indicator (surge suppression)

- Positive common

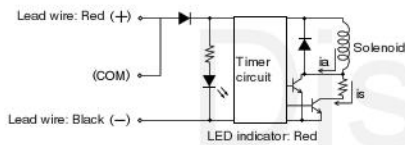

- Negative common (made to order)

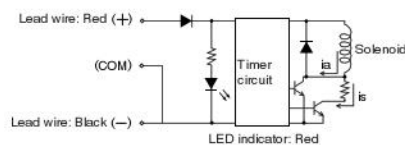

ia : Starting current is : Holding current

- AC100V, AC200V (GA010E1)

Solenoid with LED Indicator (surge suppression)

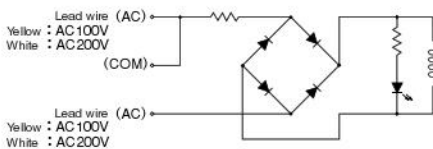

- Cautions:**
1. Do not apply megger between the lead wires.
 2. The DC solenoid will not short circuit even if the wrong polarity is applied, but the valve will not operate.
 3. Leakage current inside the circuit could result in failure of the solenoid valve not to return to home position or other erratic operation. Always use within the range of the allowable leakage current. If circuit conditions, etc., cause the leakage current to exceed the maximum allowable leakage current, consult us.



Plug connector

Attaching and removing plug connector

Use fingers to insert the connector into the pin, push it in until the lever claw latches onto the protruded section of the connector housing, and complete the connection. To remove the connector, squeeze the lever along with the connector, lift the lever claw up from the protruded section of the connector housing, and pull it out.

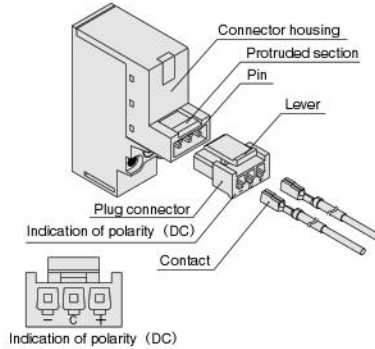

Crimping of connecting lead wire and contact

To crimp lead wires into contacts, strip off 4mm [0.16in.] of the insulation from the end of the lead wire, insert it into the contact, and crimp it. Be sure to avoid catching the insulation on the exposed wire crimping section.

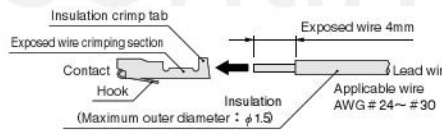

Attaching and removing contact and connector

Insert the contact with a lead wire into a plug connector hole until the contact hook latches on the connector and is secured to the plug connector. Confirm that the lead wire cannot be easily pulled out.

To remove it, insert a tool with a fine tip (such as a small screwdriver) into the rectangular hole on the side of the plug connector to push up on the hook, and then pull out the lead wire.

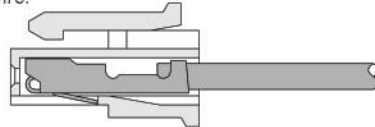

- Cautions:**
1. Do not pull hard on the lead wire. It could result in defective contacts, breaking wires, etc.
 2. If the pin is bent, use a small screwdriver, etc., to gently straighten out the pin, and then complete the connection to the plug connector.
 3. For crimping of connecting lead wire and contact, always use a dedicated crimping tool.
- Contact: Model 706312-2MK
Manufactured by Sumiko Tech, Inc.
- Crimping tool: Model FI
(For 706312-2MK)
Manufactured by Sumiko Tech, Inc.



Manual override

Locking type

To lock the manual override, use a small screwdriver to push down on the manual override all the way and turn it clockwise. When locked, turning the manual override in a counterclockwise direction releases a spring on the manual override, returns it to the original position, and releases the lock. When the manual override is not turned, this type acts just like the non-locking type, the valve will enter into the energized position as long as the manual override is pushed down, and it returns to the rest position upon release.

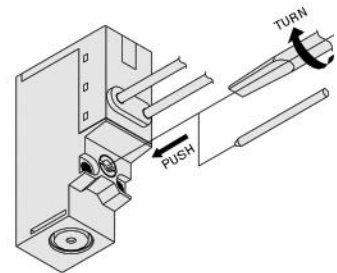

- Cautions:**
1. Always release the lock of the locking type before commencing normal operation.
 2. Do not attempt to operate the manual override with a pin or other object having an extremely fine tip. It could damage the manual override button.



Vacuum breaking

Adjustment of vacuum breaking flow rate

Turning the adjusting needle for vacuum breaking flow (with twin solenoid valves only) in the clockwise direction reduces the breaking flow rate, while turning it in the counterclockwise direction increases the breaking flow rate.

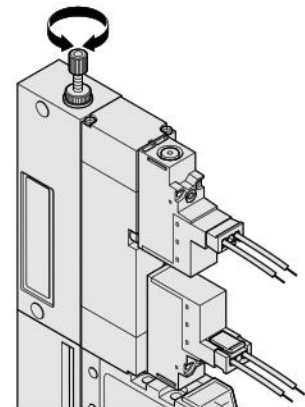

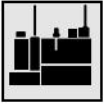

Micro ejector

Device configuration

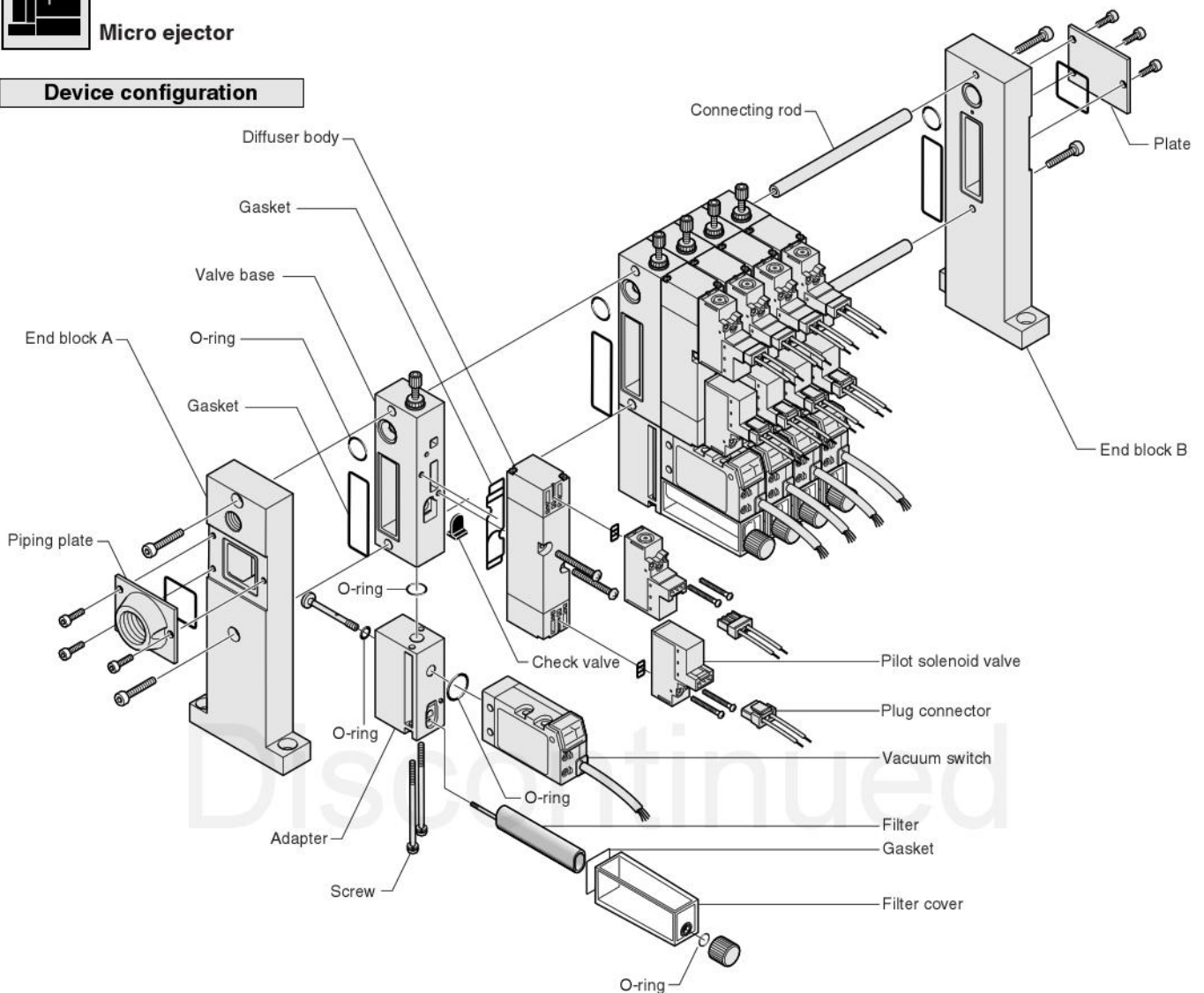

Manifold assembly

Screw the two connecting rods all the way into end block B, and then assemble the ejector bodies into the connecting rods in any order. Finally, place in end block A, and tighten hexagon socket head cap screws to secure it in place. Be sure to place both end blocks on a flat surface when tightening rods and screw.

Additional stacking method (GCME)

Remove two hexagon socket screws, and remove end block A. Screw the two supplied stacking rods into the connecting rods. At this time, check to see whether the connecting rods attached to end block B are secured. Insert the gaskets and O-rings into the locations prescribed in the illustration above, and assemble the ejector body and end blocks.

Caution: Since the ejector bodies in this GME series function as manifolds, they have no block plate. For adding units, assemble the additional stacking unit (GCME) according to the illustration above. Note that linked units cannot be reduced. Consult us in the case. (A special connecting rod is required.)

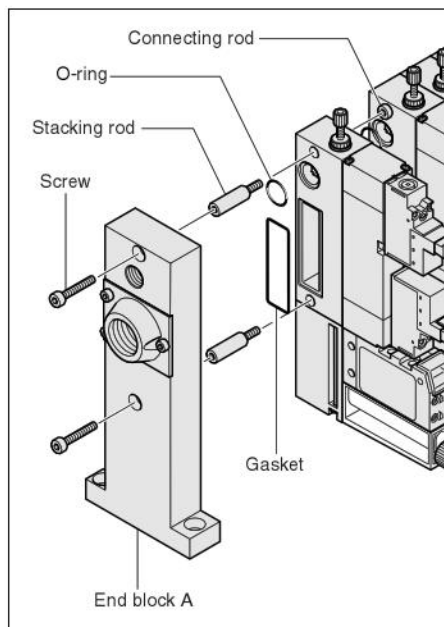

Piping

1. Connect air supply to the compressed air supply port, and connect vacuum pads, etc., to vacuum generation ports.
2. For piping to the micro ejector, use nylon or urethane tubes with inner diameters of $\phi 2.5 \sim \phi 6$ [$\phi 0.098 \sim \phi 0.236$ in.]. For vacuum generation ports, tubes in the following sizes are recommended.
GME05... $\phi 4 \times \phi 2.5$
GME07... $\phi 6 \times \phi 4$
GME10... $\phi 6 \times \phi 4, \phi 8 \times \phi 6$

- Cautions:**
1. Use a fitting that does not reduce inner diameter. A small inner diameter can result in degradation of performance, including flow rate and pressure shortages, insufficient vacuum, or longer periods of time before the vacuum level is reached.
 2. Avoid use of coil tubes and other curved piping. Also, avoid use of elbow fittings, etc., between the micro ejector and vacuum pad, and use piping that is as straight as possible.
 3. In manifolds with many units, where a large number of micro ejectors are operating simultaneously, or where the operation frequency is very high, supply air from P ports on both ends.



Electronic Vacuum Switch

Settings

●-E : Switch 2-output (fixed hysteresis) type

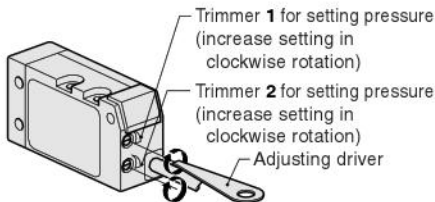

- 1) Apply pressure to operate switch 1, and turn and set trimmer 1 for setting pressure. (LED: red)
- 2) Apply pressure to operate switch 2, and turn and set trimmer 2 for setting pressure. (LED: green)

●-EA : Switch 1-output (variable hysteresis) + analog output type^{Note}

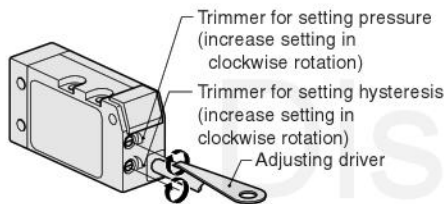

- 1) Use the trimmer for setting hysteresis to set the hysteresis to a suitable one.
- 2) Apply pressure to operate the switch, and turn and set the trimmer for setting pressure.
- 3) Repeat 1) and 2) above, and determine the set point.

Cautions: 1. Do not apply excessive force when handling the trimmer for setting.
2. Do not exceed the rotation torque of the trimmer for setting hysteresis 4.4N · cm [0.39in · lbf].

Wiring instructions

Basic connections

●GME-□E Switch 2-output (fixed hysteresis) type

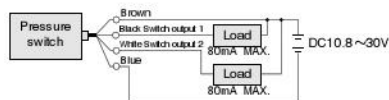

●GME-□EA Switch 1-output (variable hysteresis) + analog output type

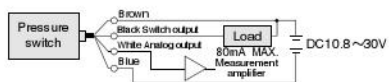

Connections to programmable controller

●GME-□E Switch 2-output (fixed hysteresis) type

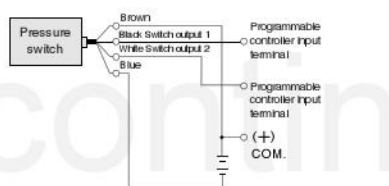

●GME-□EA Switch 1-output (variable hysteresis) + analog output type^{Note}

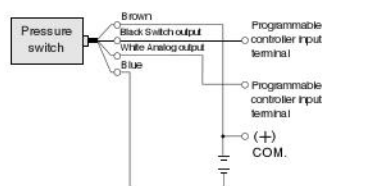

Cautions: 1. Use a stable DC power supply. If using switching power supply or other unit power supply, use with an FG terminal for the ground.
2. Make connections with due attention to the colors of the lead wires. Connection errors could result in erratic operation or damage.
3. Do not short-circuit the switch output terminal with other terminals, and do not connect low-resistance loads where the current exceeds 80mA. This could damage the internal circuit.
4. Use a surge suppression diode, etc., for solenoid relays or other inductive loads.



General precautions

Mounting

1. Although any mounting direction is allowed, always ensure that the ejector body is not directly under strong shocks or vibrations.
2. Avoid using in the locations or environments listed below, because they could be the cause of valve malfunctions. If use in such areas cannot be avoided, always use a cover or take other sufficient protective measures.
 - Locations where the valve is directly subject to dripping water, dripping oil, etc.
 - Environments where the valve body is subject to condensation
 - Locations where the valve is directly subject to chips, dust, etc.
 - Locations subject to salt, corrosive gases, or conductive particles
3. Always thoroughly blow off (use compressed air) the piping before connecting it to the micro ejector. Intrusion into the piping of chips, sealing tape, rust, or other foreign material generated during piping operations could result in valve air leaks or a degradation in micro ejector performance.
4. Use clean air that does not contain deteriorated compressor oil or other contaminants. Install an air filter (with filtration of a minimum 40 μm) close to the micro ejector to eliminate any collected liquid or dust in air line. Always use a mist filter for cases where the compressed air contains large amounts of oils. Moreover, drain the air filter at regular intervals.
5. Use a regulator to adjust the pressure of air supplied to the micro ejector. Where the piping length to the micro ejector is long, set the pressure at a little higher than normal. If using an air supply valve, use a valve with an effective area that is at least three times as large as the area of the micro ejector nozzle.
6. Use one vacuum pad for one micro ejector. Use of two or more pads could result in picking errors, and extend the amount of time required to reach the set vacuum level.
7. Periodically replace the filter installed as standard equipment (Order code: GME-□F) with the micro ejector body.
8. Do not use corrosive gases or fluids for the media.
9. Do not apply pressure to the vacuum switch that exceeds the maximum pressure.
10. Do not subject lead wires to strong tension or excessive bending force. In addition, always carry the product by the body for handling, and do not apply excessive force to the power cord.
11. A mounting base (GME-21) is available for mounting the micro ejector as a single unit. Use the base and a spacer to assemble the micro ejector into place, and tighten hexagon socket head cap screws (tightening torque 59N · cm) [5.2in · lbf].

Wiring

After completing all wiring, be sure to check for no error in the wiring connections.

Air Consumption, Vacuum and Vacuum Flow Rate

● GME05

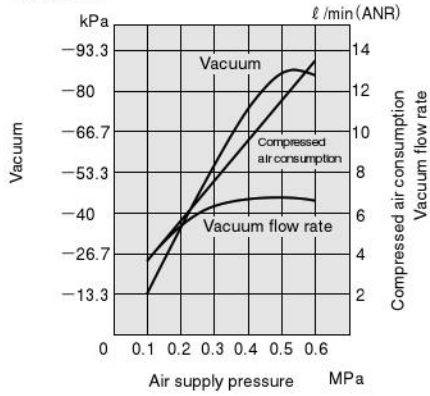

● GME07

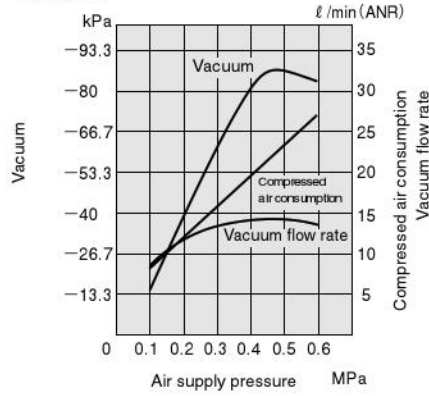

● GME10

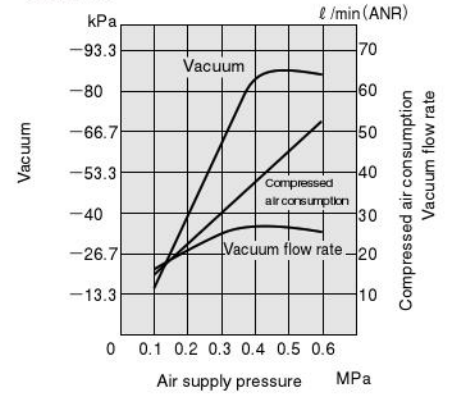

1MPa = 145psi. 1kPa = 0.145psi. 1 l/min = 0.0353ft³/min. -100kPa = -29.54in.Hg

Calculation of the Micro Ejector Response Time

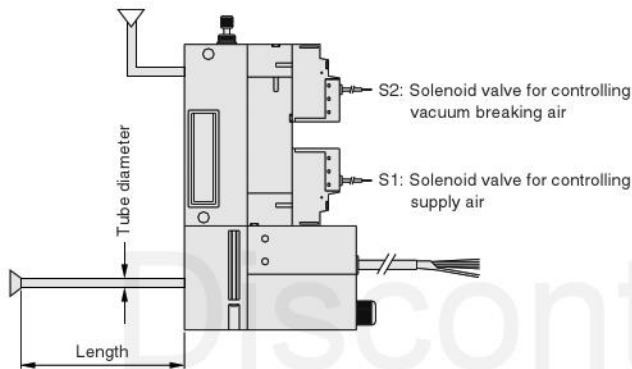

Use the following equation and table of constants to calculate the picking time, and allow for sufficient margin in making the selection.

$$T = \left(\frac{L}{C}\right)^a$$

L : Vacuum piping internal capacity [ℓ]

C : Constant of vacuum

a : Index of nozzle diameter

T : Time to reach vacuum [s]

Basic models	C : Constant of vacuum					a Index
	-40kPa [-11.8in.Hg]	-53.3kPa [-15.7in.Hg]	-66.7kPa [-19.7in.Hg]	-80kPa [-23.6in.Hg]	-86.7kPa [-25.6in.Hg]	
GME05	0.23	0.12	0.065	0.035	0.025	0.98
GME07	0.42	0.25	0.14	0.08	0.055	0.98
GME10	0.77	0.46	0.29	0.16	0.1	0.94

[Example]

● Calculate the piping capacity.

Calculate the piping capacity from the vacuum generation port to the vacuum pad.

In GME05, when the vacuum piping is $\phi 4 \times \phi 2.5$ (O.D. \times I.D.), with length 50cm, and vacuum -80kPa

$$L = 0.0025 [\ell] \left(\frac{\pi \times 0.25^2}{4} \times 50 \div 1000 \right)$$

$$C = 0.035$$

$$a = 0.98$$

$$T = \left(\frac{0.0025}{0.035}\right)^{0.98}$$

$$T = 0.08 [s]$$

$$\left[L = \frac{\pi \times (2.5/25.4)^2}{4} \times 19.7 = 0.15 \text{in}^3 \right]$$

$$= 0.0025 [\ell]$$

MICRO EJECTORS

ME03, ME05, ME07

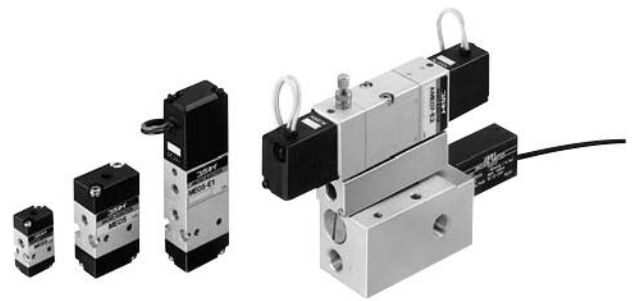

Specifications

Basic model		ME03 □ME03-E1	ME05 □ME05-E1	AME05-E2	ME07 □ME07-E1	AME07-E2
Media		Air				
Operating pressure range MPa [psi.]		0.1~0.6 [15~87]	0.1~0.6 [15~87]	0.2~0.6 [29~87]	0.1~0.6 [15~87]	0.2~0.6 [29~87]
Proof pressure MPa [psi.]		1.03 [149]				
Operating temperature range °C [°F] (atmosphere and media)		Without solenoid valve				
		0~50 [32~122] (No freezing)				
		With solenoid valve				
		5~50 [41~122]				
Nozzle diameter mm [in.]		0.3 [0.012]	0.5 [0.020]		0.7 [0.028]	
Vacuum ^{Note 1} kPa [in.Hg]		-80 [-23.6]	-86.7 [-25.6]			
Vacuum flow rate ^{Note 1} ℓ /min [ft. ³ /min.] (ANR)		3.0 [0.106]	6.3 [0.222]		12.5 [0.441]	
Compressed air consumption ^{Note 1} ℓ /min [ft. ³ /min.] (ANR)		4.5 [0.159]	11.5 [0.406]		23.0 [0.812]	
Lubrication		Prohibited				
Filtration μm		30 (manifold only)				
Port size ^{Note 2}		Vacuum generation port		M5×0.8		Rc1/8
		Compressed air supply port		M3×0.5	M5×0.8	Rc1/8
Mounting direction		Any				
Main valve specifications		Operation type				
		Direct operating				
		Number of positions, number of ports				
		2 positions, 2 ports				
		Valve function				
		Normally closed (NC standard) or normally open (NO optional)				
Effective area mm ² [Cv]		0.2 [0.01]	0.6 [0.03]		0.8 [0.04]	
Shock resistance		Piping direction m/s ² [G]		1372.9 [140]		1372.9 [140]
		Axial direction m/s ² [G]		588.4 [60]		117.7 [12]
Manual override		Non-locking type (Standard)		Non-locking type (standard) or locking protruding type (Optional)		

Notes: 1. Value (approximate) at pressure of 0.5MPa [73psi.]. For details, see p.702.

2. For details, see the port size table.

Solenoid Specifications

Rated voltage		DC12V	DC24V	AC100V	AC200V
Item		Micro ejector basic model			
		□ME03-E1 ^{Note}	□ME05-E□	□ME07-E□	
Type		With built-in flywheel diode for surge suppression		Shading type	
Operating voltage range V		10.8~13.2 (12±10%)	21.6~26.4 (24±10%)	90~132 (100±32%)	180~264 (200±32%)
Current (When rated voltage is applied)		Frequency Hz		50	60
		Starting mA(r.m.s.)		36	32
		Energizing mA(r.m.s.) (with LED indicator)		130 (140)	70 (80)
Maximum allowable leakage current mA		15	5	4	2
Insulation resistance MΩ		100 or more			
Wiring and lead wire length		Standard			
		Grommet type : 300mm			
		Optional			
		Plug connector type: 300mm, (1L : 1000mm) Made to order (3L : 3000mm)			
Color of lead wire		Brown (+) Black (-)	Red (+) Black (-)	Yellow	White
Color of LED indicator (Optional)		Red		Yellow	Green
Surge suppression (as standard)		Flywheel diode		Varistor	

Note: ME003-E1 can be manufactured at DC5V and DC6V. For delivery times, consult us.

Electronic Vacuum Switch Specifications

Item	Model	PS310E	
Media		Air or non-corrosive gas	
Operating temperature range °C [°F]		-10~60 [14~140] (No freezing)	
Operating humidity range %RH		35~95	
Operating pressure range kPa [in.Hg]		-101.3~0 [-29.92~0]	
Proof pressure MPa [psi.]		0.2 [29]	
Pressure setting range kPa [psi.]		-101.3~10.1 [-14.7~1.5]	
Hysteresis ^{Note} %		2~9	
Repeatability		Within ±3%FS (0~50°C) [32~122°F]	
Electrical specifications		Operating type	
		NPN open collector output, NO type (Output ON when falls below set pressure)	
		Operating voltage range DCV	
		12~24±10% (ripple Vp-p10%) or less	
		Switching capacity	
DC30V, 100mA or less (Internal voltage drop: 1V or less at load current 100mA, 0.4V or less at load current 16mA)			
Consumption current mA MAX.		20	
Insulation resistance MΩ		100 or more (DC500V megger, between charging part and case)	
Surge suppression		Zener diode (As standard)	
Mechanical characteristics		Shock resistance m/s ² [G]	
		490.3 [50]	
Vibration resistance		10~55Hz (total amplitude 1.5mm [0.06in.]) or 98.1m/s ² [10G] (2 hours at each X-, Y-, Z-axis MAX.)	
Operations indicator		When ON, LED indicator lights up	
Lead wire		Vinyl cabtyre: 0.14SQ X3-lead X500mm (Overall length)	
Mounting direction		Any	
Materials (Body cover)		Plastic	

Note: Values are at a set pressure of -86.7kPa [-25.6in.Hg].

Port Size

Basic model		Port size	
		Vacuum generation port	Compressed air supply port
Micro ejector	ME03, ME03-E1	M5×0.8	M3×0.5
	ME05, ME05-E1	M5×0.8	
	ME07, ME07-E1	Rc1/8	M5×0.8
Manifold	ME03M□A	M5×0.8	Rc1/8
	ME05M□A, ME05M□AS	M5×0.8	Rc1/8
	ME07M□A, ME07M□AS	Rc1/8	

Micro Ejector Order Codes

● Micro ejector single unit (without solenoid valve)

ME

Body model nozzle diameter : Maximum flow rate on vacuum side
03 ——— ϕ 0.3 : 3.0 ℓ /min. [ϕ 0.012in., 0.106ft³/min.] (ANR)
05 ——— ϕ 0.5 : 6.3 ℓ /min. [ϕ 0.020in., 0.222ft³/min.] (ANR)
07 ——— ϕ 0.7 : 12.5 ℓ /min. [ϕ 0.028in., 0.441ft³/min.] (ANR)

Micro ejector

● Micro ejector with solenoid valve

- - - - - -

Voltage
DC12V (only for ME03-E1)
DC24V
AC100V (only for ME05 and 07)
AC200V (only for ME05 and 07)

Solenoid
Blank ——— Grommet
PSL ^{Note 2} ——— Straight connector
 (with LED indicator)
PLL ^{Note 2} ——— L connector
 (with LED indicator)

Manual override
Blank ——— Non-locking type
83 ——— Protruding locking type
 (only for ME05 and 07)

Solenoid valve function ^{Note 1}
Blank ——— Normally closed (NC)
11 ——— Normally open (NO)

Solenoid valve specifications
E1 ——— With single solenoid valve for controlling supply air
E2 ——— With twin solenoid valves for controlling supply air and
 vacuum breaking air (only for AME05 and 07)

Body model nozzle diameter : Maximum flow rate on vacuum side
03 ——— ϕ 0.3 : 3.0 ℓ /min. [ϕ 0.012in., 0.106ft³/min.] (ANR)
05 ——— ϕ 0.5 : 6.3 ℓ /min. [ϕ 0.020in., 0.222ft³/min.] (ANR)
07 ——— ϕ 0.7 : 12.5 ℓ /min. [ϕ 0.028in., 0.441ft³/min.] (ANR)

Micro ejector

ME ——— For single unit

AME ——— For manifold mounting

Notes: 1. Only for solenoid valve for controlling supply air. The solenoid valve for controlling vacuum breaking air is normally closed (NC) only.
 2. Lead wires in the 1L: 1000mm [39in.] and 3L: 3000mm [118in.] lengths are available as made to order for the plug connector type.

Electronic Vacuum Switch Order Codes

- **DC24V** -

Lead wire length
Blank ——— 500mm
L ——— 2000mm

Switch for DC12~24V

Electronic vacuum switch
PS310 ——— Only body
PS310E ——— For mounting on AS type manifold (with gasket and spring pin)
PS310E-01 ——— For mounting on a single unit (R1/8 male thread specification)

Manifold Order Codes

- - - - - -

Electronic vacuum switch
Blank ——— No vacuum switch
E ——— With vacuum switch ^{Note 2}
 (only for AS type manifold)

Mounting micro ejector model ^{Note 1}
AME03-E1 - - - -
AME05-E - - - -
AME07-E - - - -

Station
 (The micro ejector mounting positions are listed from the left with the vacuum generation port in front.)

stn.1 ——— Station 1
stn.2 ——— Station 2
 :
 :
stn.5 ——— Station 5

Manifold model
A ——— A type manifold (P, V manifold)
AS ——— AS type manifold (P, V manifold for mounting vacuum switch, only for ME05M and ME07M)

Number of units
1 ——— One unit
2 ——— Two units
 :
 :
5 ——— Five units

Manifold basic model
ME03M ——— For mounting AME03-E1
ME05M ——— For mounting AME05-E
ME07M ——— For mounting AME07-E

Notes: 1. For mountings of micro ejector options, see the micro ejector order codes. Also, if not mounting a micro ejector, and placing a block-off plate on the station instead, enter **-BP**.
 2. Lead wires in the 2000mm [79in.] length are available as made to order for the electronic vacuum switch.

Additional Parts (to be ordered separately)

● Block-off plate

ME MA-BP
03 ——— For ME03M
05 ——— For ME05M
07 ——— For ME07M

● Replacement filter

ME MA-F
03 ——— For ME03M
05 ——— For ME05M
07 ——— For ME07M

Operation Principle and Major Parts

● De-energized

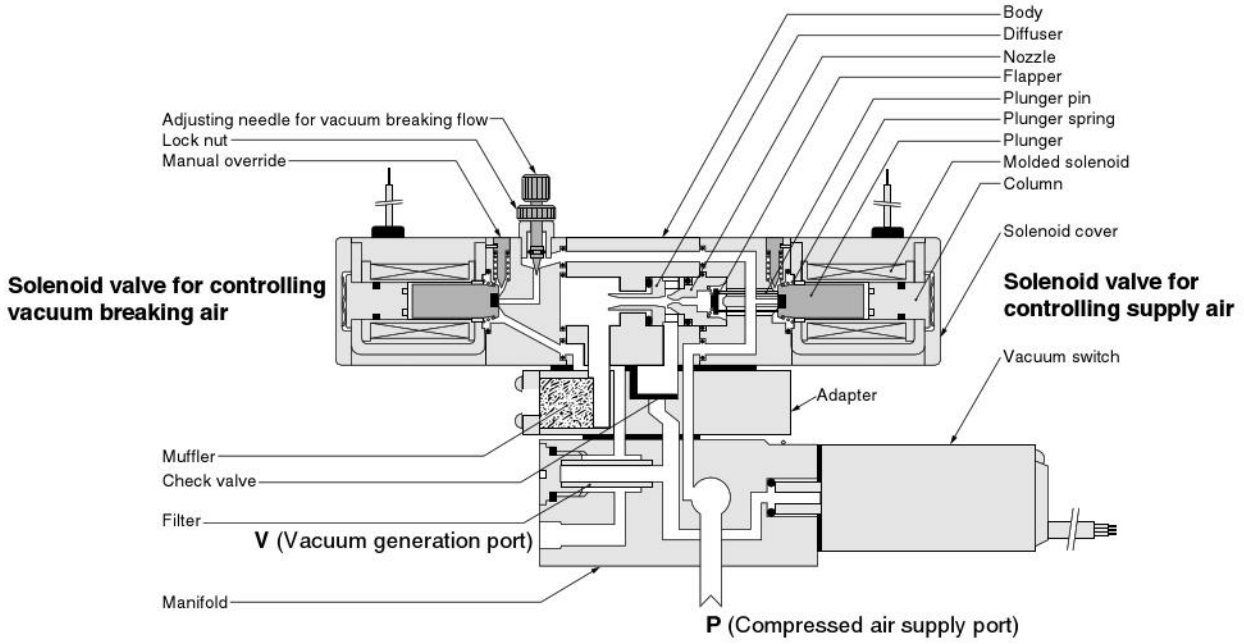

● When energizing a solenoid valve for controlling supply air (generating vacuum)

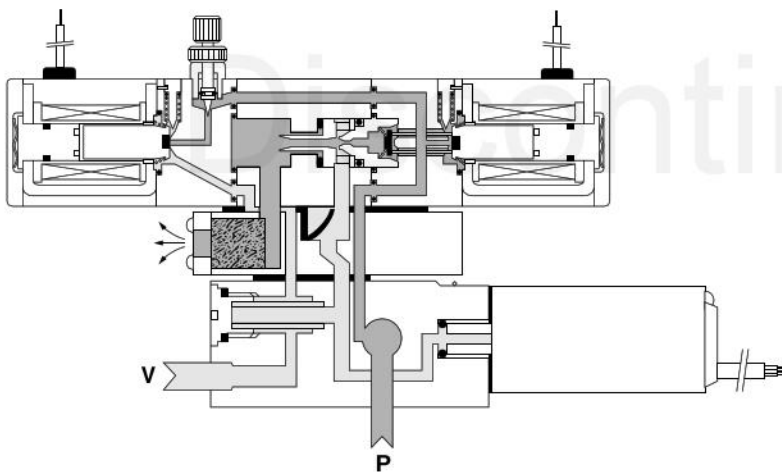

● When energizing solenoid valve for controlling vacuum breaking air

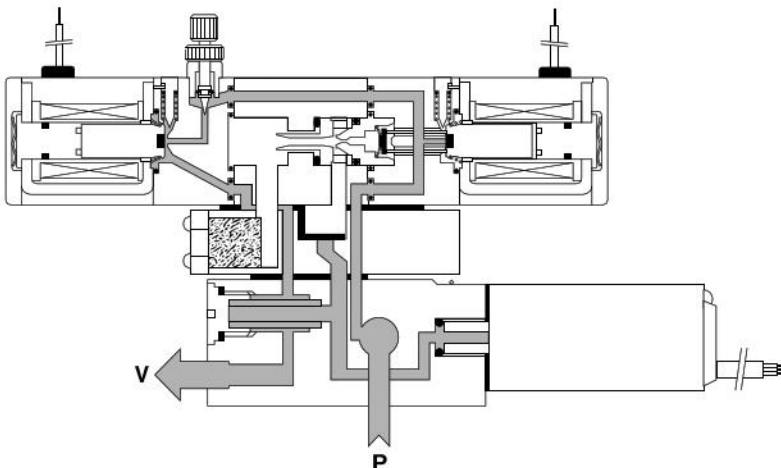

Major Parts and Materials

Parts		Materials
Micro ejector	Body	Aluminum alloy (anodized)
	Adapter	Aluminum alloy (anodized)
	Nozzle, diffuser	Brass
	O-ring	Synthetic rubber (NBR)
	Gasket	Synthetic rubber (NBR)
	Plunger	Magnetic stainless steel
Manifold	Column	Magnetic stainless steel
	Body	Aluminum alloy (anodized)
	Seal	Synthetic rubber (NBR)
	Filter	Plastic (PVF)
	Block-off plate	Mild steel (nickel plated)

Symbols

Single unit

●ME03 ●ME05 ●ME07

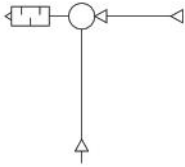

With single solenoid valve

●ME03-E1 ●ME05-E1 ●ME07-E1

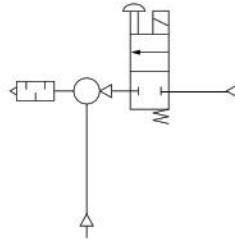

With single solenoid valve

●AME03-E1 ●AME05-E1 ●AME07-E1
(Manifold mounted)

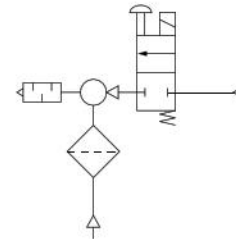

With single solenoid valve and vacuum switch

●AME05-E1-□-E ●AME07-E1-□-E
(AS type manifold mounted)

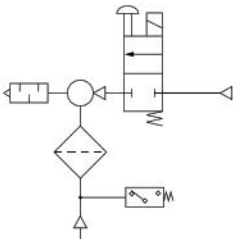

With twin solenoid valves

●AME05-E2 ●AME07-E2
(Manifold mounted)

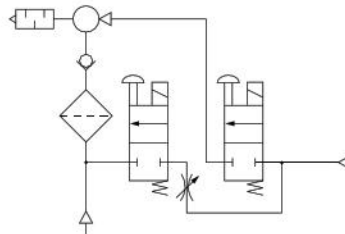

With twin solenoid valves and vacuum switch

●AME05-E2-□-E ●AME07-E2-□-E
(AS type manifold mounted)

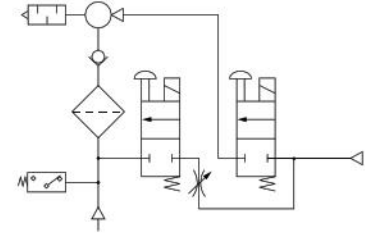

Mass

●Micro ejectors

g [oz.]

Item	Basic model	ME03	ME05	ME07
Without solenoid valve		9 [0.32]	34 [1.20]	52 [1.83]
With single solenoid valve ME□-E1		24 [0.85]	80 [2.82]	103 [3.63]

●With electronic vacuum switch

PS310E (For mounting AS type manifold).....21g [0.74oz.]
PS310E-01 (For mounting single unit).....38g [1.34oz.]

●Manifolds

g [oz.]

Item	Model	ME03		ME05		ME07	
		ME03M□A	ME05M□A	ME05M□AS	ME07M□A	ME07M□AS	
Manifold body for number of units	1 unit	26 [0.92]	62 [2.19]	81 [2.86]	120 [4.23]	148 [5.22]	
	2 units	49 [1.73]	118 [4.16]	154 [5.43]	237 [8.36]	292 [10.30]	
	3 units	64 [2.26]	156 [5.50]	202 [7.13]	313 [11.04]	385 [13.58]	
	4 units	80 [2.82]	193 [6.81]	251 [8.85]	389 [13.72]	478 [16.86]	
	5 units	95 [3.35]	231 [8.15]	299 [10.55]	465 [16.40]	571 [20.14]	
Additional mass	With single solenoid valve -AME□-E1	25 [0.88]	83 [2.93]		108 [3.81]		
	With twin solenoid valve -AME□-E2	—	167 [5.89]		216 [7.62]		
	With electronic vacuum switch -E	—	—	21 [0.74]	—	21 [0.74]	
	Block-off plate -BP	2 [0.07]	6 [0.21]		13 [0.46]		

Calculation example : ME05M5AS

stn.1~2-AME05-E1

stn.3~4-AME05-E2-E

stn.5 mass of -BP 299 + (83 × 2) + (167 + 21) × 2 + 6 = 847g [29.88oz.]

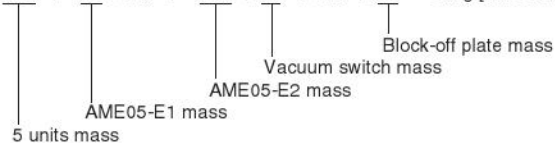

Dimensions of ME03 (mm)

ME03

Single unit

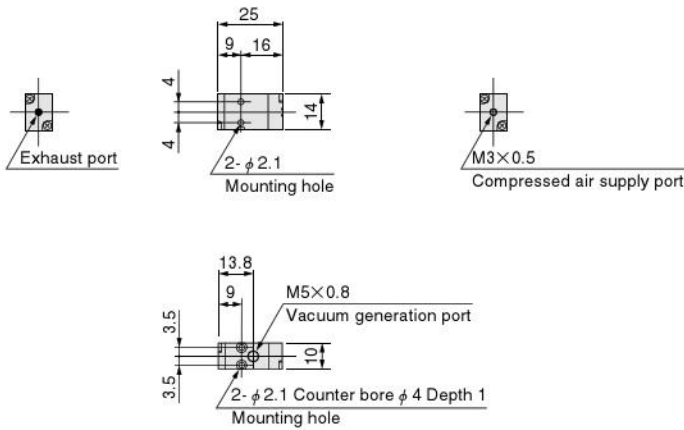

ME03-E1

With solenoid valve

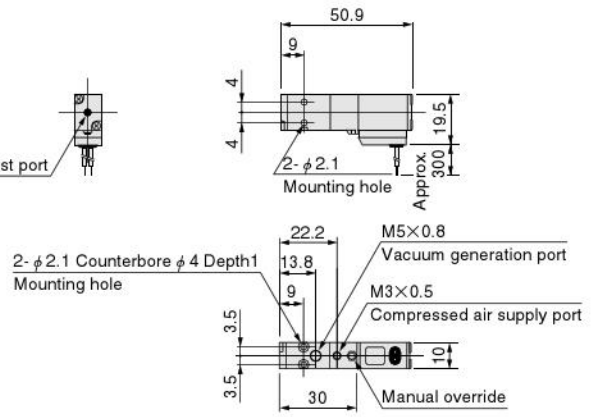

ME03M□A

A type manifold

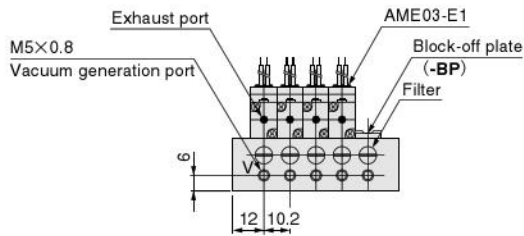
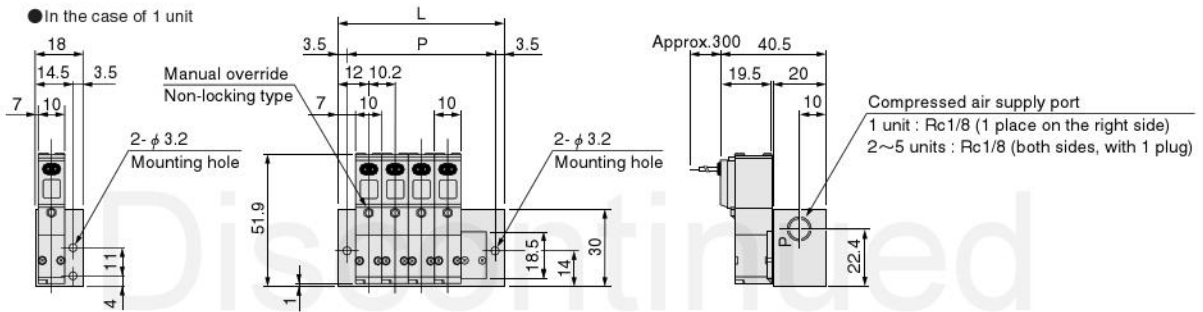

Unit dimensions

Model	L	P
ME03M2A	34.2	27.2
3A	44.4	37.4
4A	54.6	47.6
5A	64.8	57.8

Options

● Solenoid with straight connector: -PSL

● Solenoid with L connector: -PLL

● Lead wire length ℓ -PSL, -PLL: 300

Made to order: 1L: 1000

3L: 3000

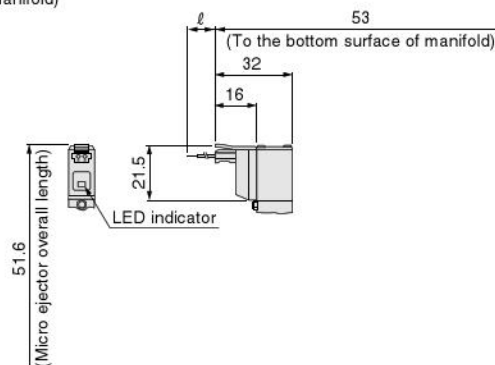
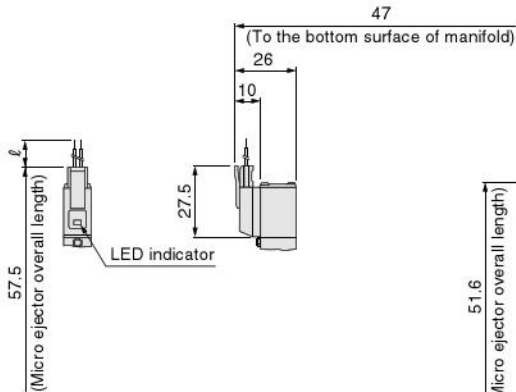

Dimensions of ME05 (mm)

ME05

Single unit

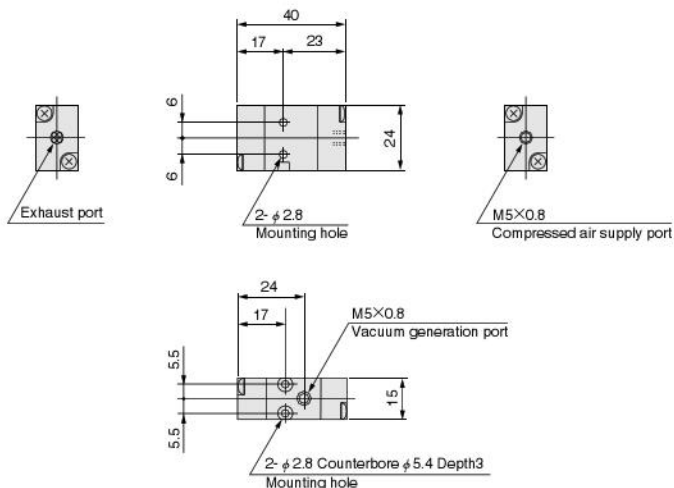

ME05-E1

With solenoid valve

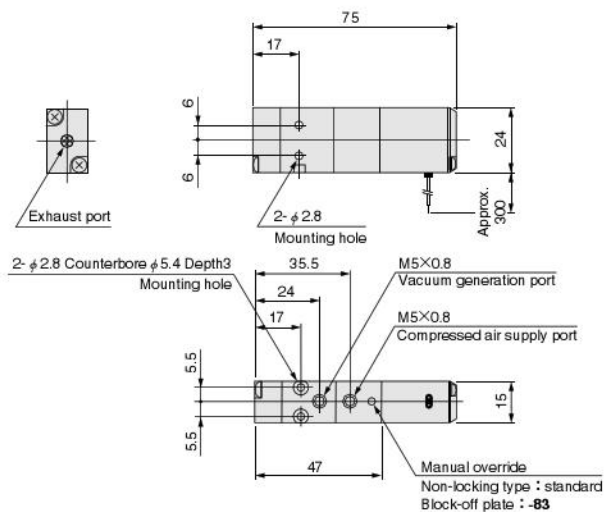

ME05M□A

A type manifold

● In the case of 1 unit

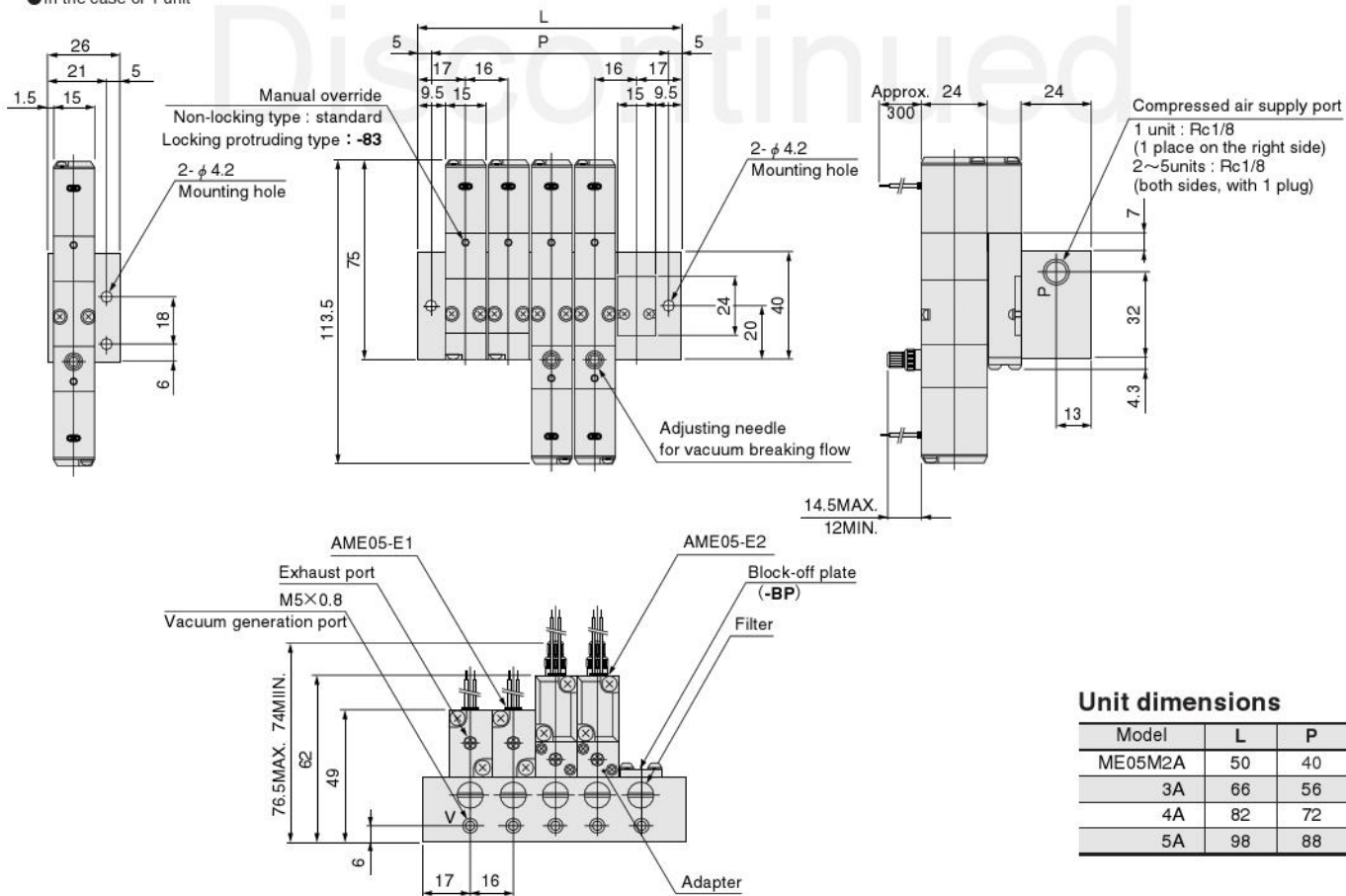

MICRO EJECTORS

Dimensions of ME05 (mm)

ME05M□AS

AS type manifold

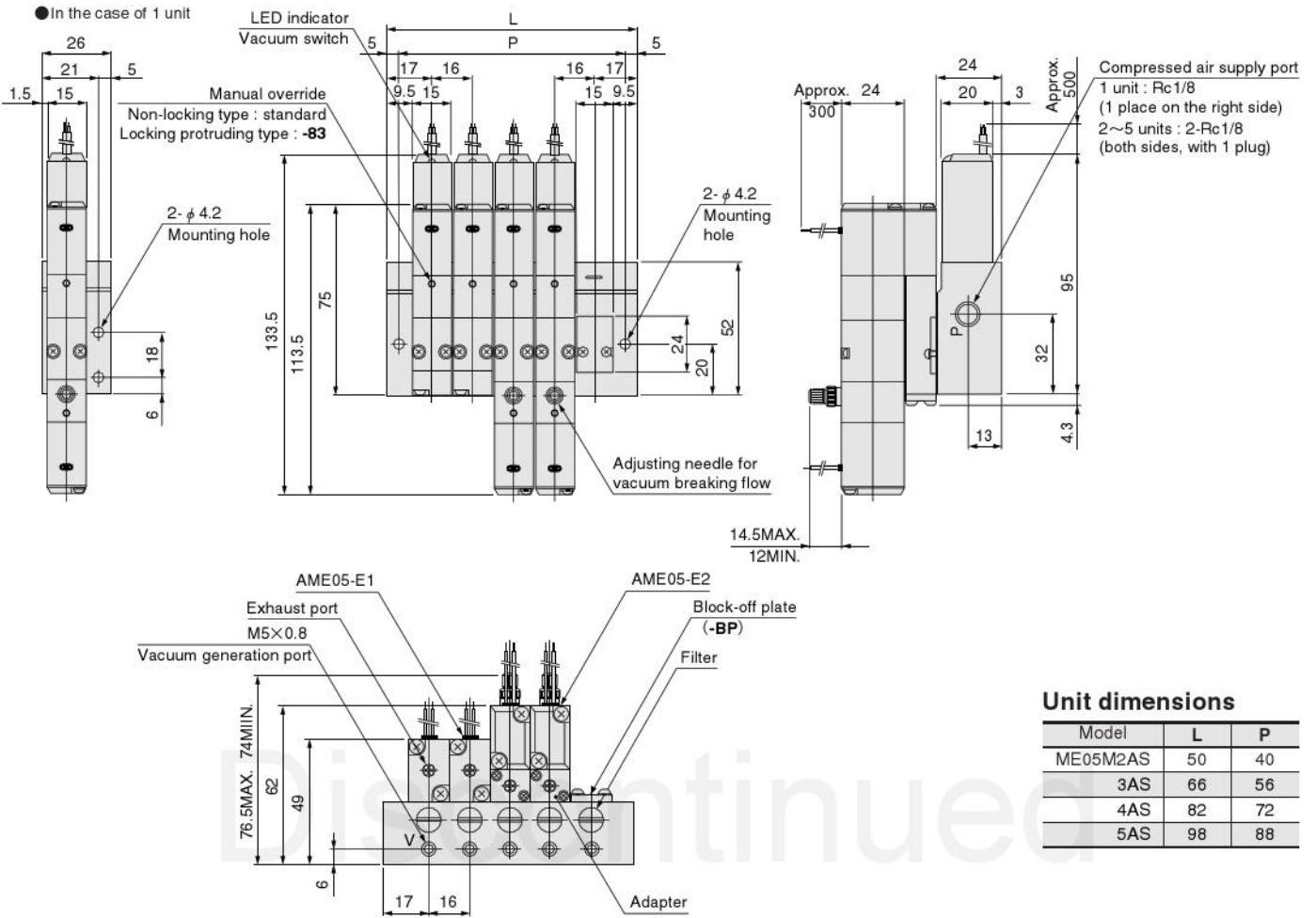

Unit dimensions

Model	L	P
ME05M2AS	50	40
3AS	66	56
4AS	82	72
5AS	98	88

Options

● Solenoid with straight connector : **-PSL**

● Solenoid with L connector : **-PLL**

● Locking protruding type manual override : **-83**

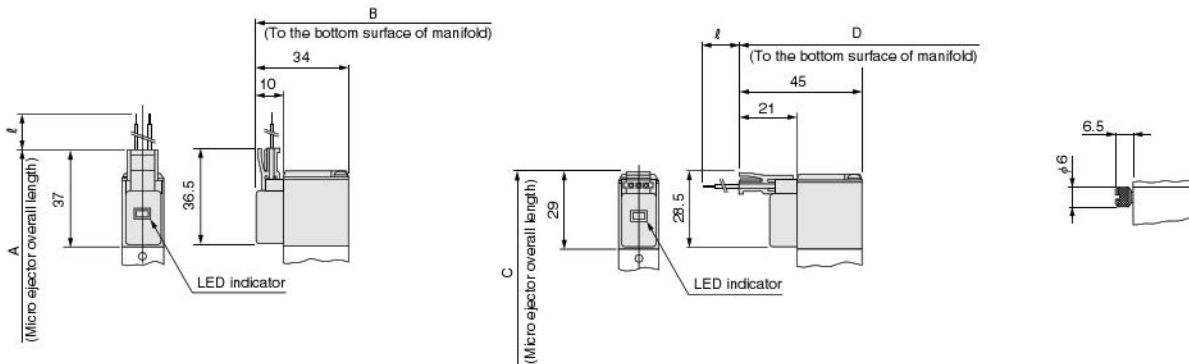

Model	Code	A	B	C	D	l (Lead wire length)
ME05-E1, AME05-E1		84	59	76	70	-PSL, -PLL : 300 Made to order : 1L ; 1000, 3L ; 3000
AME05-E2		131.5	72	115.5	83	

Dimensions of ME07 (mm)

ME07M□AS

AS type manifold

● In the case of 1 unit

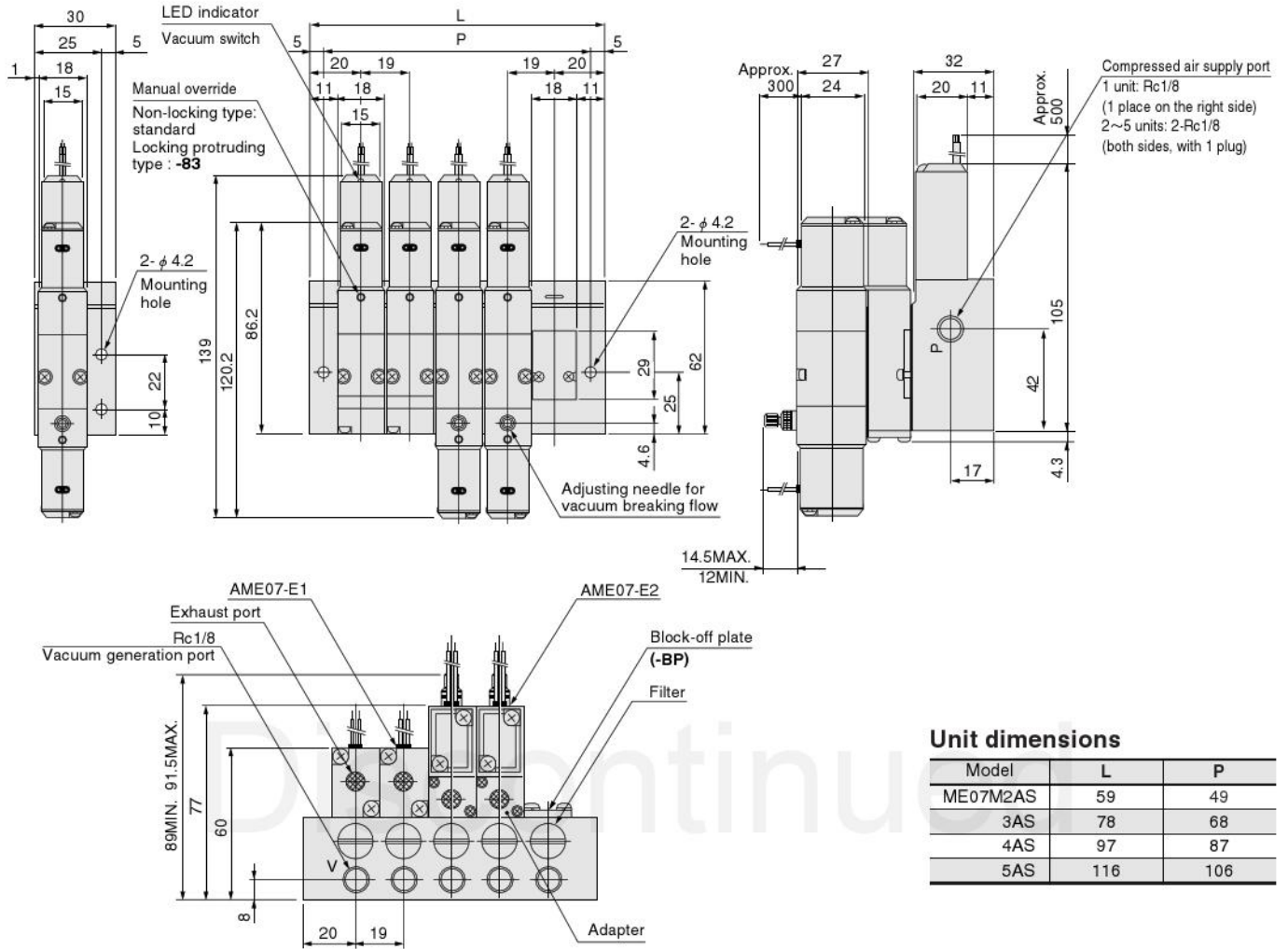

Unit dimensions

Model	L	P
ME07M2AS	59	49
3AS	78	68
4AS	97	87
5AS	116	106

Options

● Solenoid with straight connector : -PSL

● Solenoid with L connector : -PLL

● Locking protruding type manual override : -83

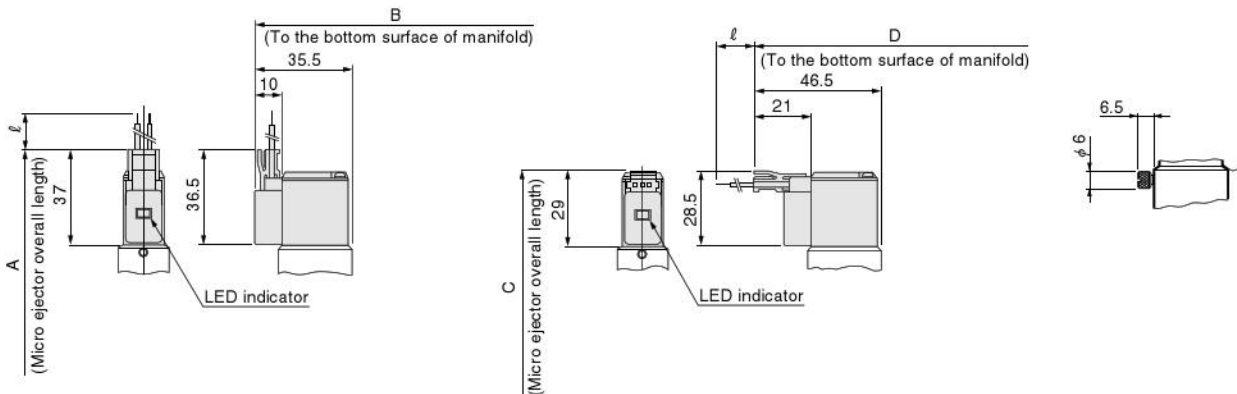

Model	Code	A	B	C	D	l (Lead wire length)
ME07-E1, AME07-E1		95.2	68.5	87.2	79.5	-PSL, -PLL : 300
AME07-E2		138.2	85.5	122.2	96.5	Made to order : 1L ; 1000, 3L ; 3000

Dimensions of Electronic Vacuum Switch (mm)

PS310E-01

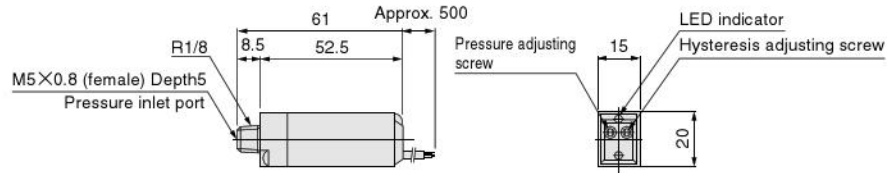

Air Consumption, Vacuum and Vacuum Flow Rate

ME03

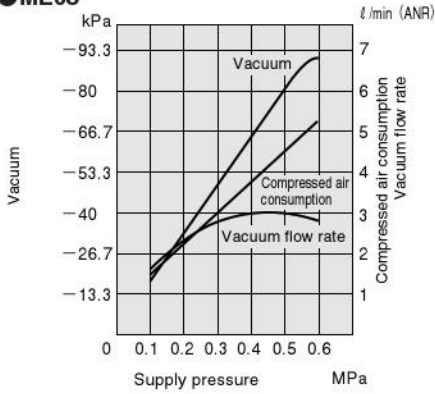

ME05

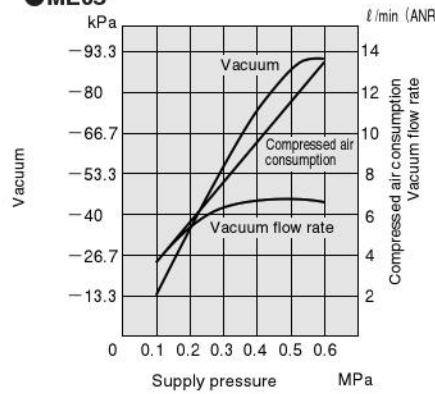

ME07

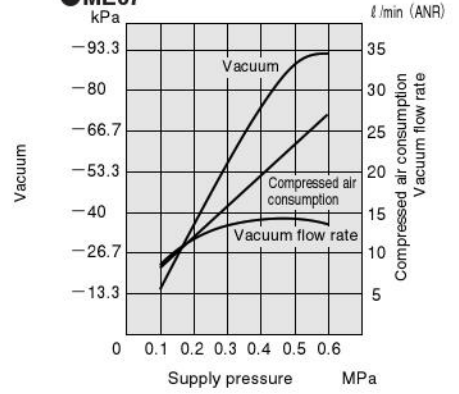

Remark: Graphs are for each single ejector unit. If the unit with solenoid valve requires the same vacuum level, set the supply pressure 0.03~0.05MPa [4.4~7.3psi.] higher than the single ejector unit's case.

1MPa = 145psi. 1kPa = 0.145psi. -100kPa = -29.54in.Hg 1 l/min = 0.0353ft³/min.

Time to Reach Vacuum and Vacuum Breaking Time

Measurement method

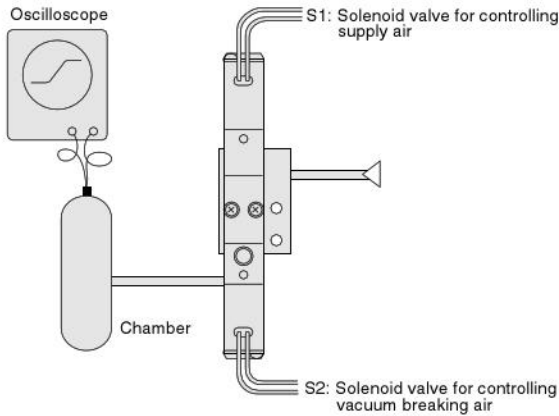

ME□-E1

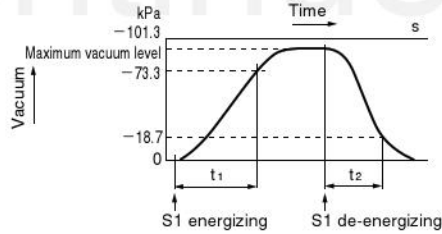

Air pressure: 0.5MPa [73psi.]
Adjusting needle for vacuum breaking flow: Fully open
t₁: Time to reach -73.3kPa [-21.65in.Hg] in the chamber after energizing S1.

t₂: In ME□-E1, time to reach -18.7 kPa [-5.52in.Hg] in the chamber after de-energizing S1.

ME□-E2

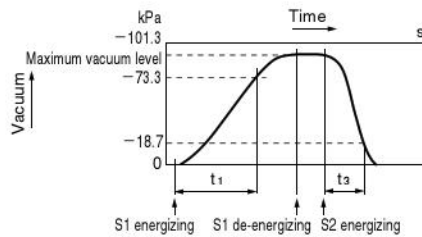

t₃: In ME□-E2, time to reach -18.7kPa [-5.52in.Hg] in the chamber after energizing S2 and when vacuum was at its maximum level.

Response time

Model	Time	5 [0.305]			10 [0.610]			20 [1.22]			50 [3.05]			100 [6.10]			200 [12.2]			500 [30.5]		
		t ₁	t ₂	t ₃	t ₁	t ₂	t ₃	t ₁	t ₂	t ₃	t ₁	t ₂	t ₃	t ₁	t ₂	t ₃	t ₁	t ₂	t ₃	t ₁	t ₂	t ₃
ME03		0.4	0.1	—	0.7	0.2	—	1.1	0.3	—	3.2	0.6	—	5.8	1.1	—	—	—	—	—	—	—
ME05		0.2	0.1	0.1	0.3	0.1	0.1	0.5	0.1	0.1	1.5	0.3	0.1	2.6	0.5	0.2	7.0	0.8	0.4	12.0	1.8	0.8
ME07		0.1	0.1	0.1	0.2	0.1	0.1	0.3	0.1	0.1	0.6	0.2	0.1	1.0	0.3	0.2	1.8	0.4	0.4	4.7	1.0	0.8

Note: Some degree of variation may occur due to piping size and chamber shape. The figures can be viewed as a guide.

Handling Instructions and Precautions

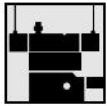

Micro Ejector

Device configuration

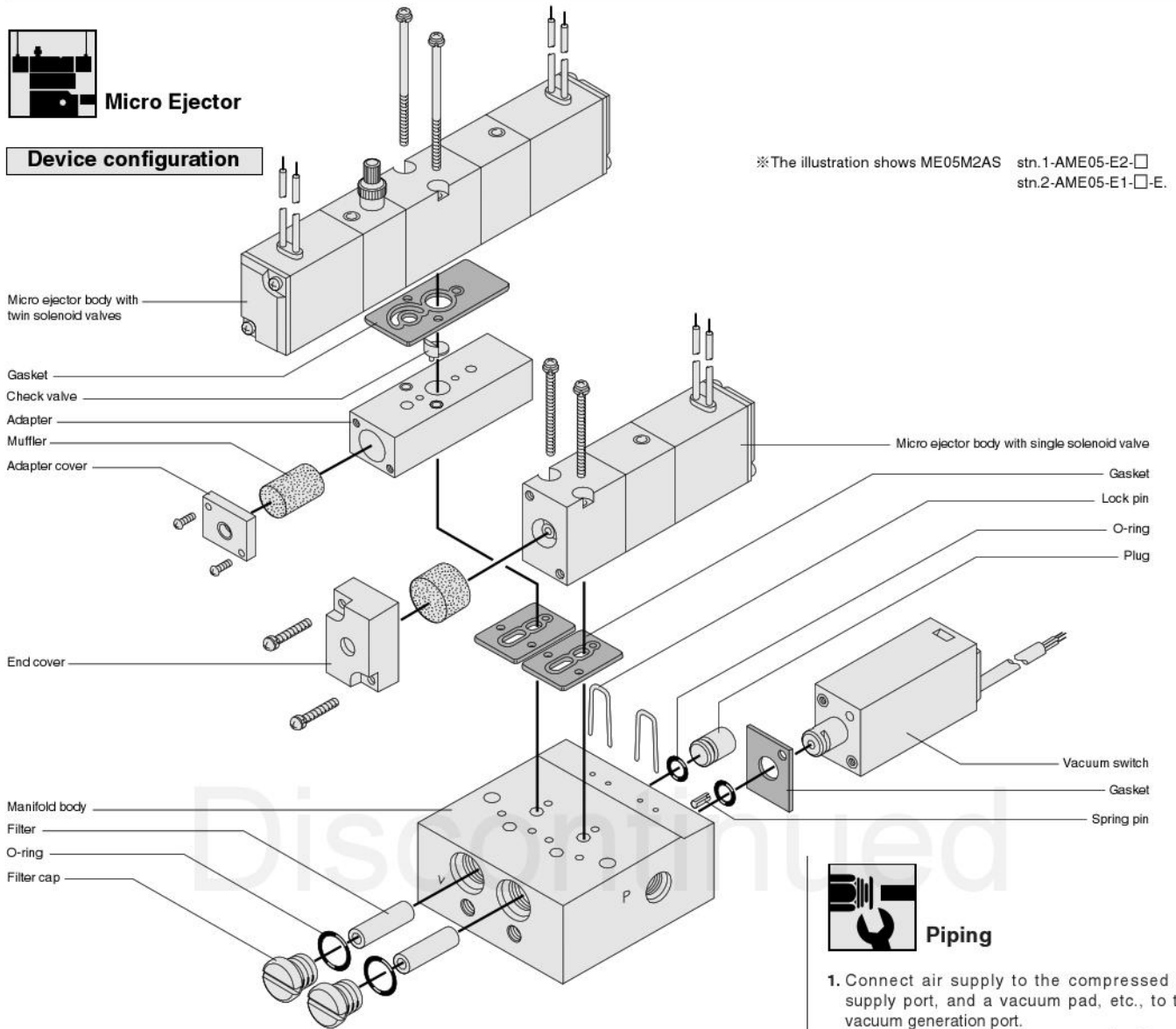

※The illustration shows ME05M2AS strn.1-AME05-E2-□
strn.2-AME05-E1-□-E.

Functions

In addition to a single unit, the Micro Ejector ME03/05/07 series offer models with single solenoid valves for controlling supply air, and with twin solenoid valves for controlling supply air and vacuum breaking air (twin solenoid valves are for AME05/07 only). The unit with twin solenoid valves uses supply of pressurized air to the vacuum side to enable vacuum breaking and blow-off release, and makes use of an adjusting needle for vacuum breaking flow to enable flexible setting of breaking flow. In addition, a built-in check valve ensures that the setting of vacuum level can be maintained even when the power to the solenoid valve for controlling supply air has been switched off, attaining energy savings.

●Control circuit for economizing on air consumption volume when the vacuum is being maintained for long periods of time

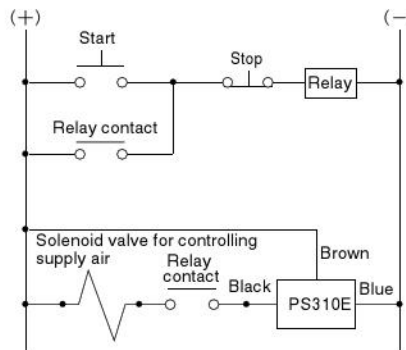

Remark: The above diagram shows the case when the solenoid valve for controlling supply air is normally open (NO; order code: -11).



Piping

1. Connect air supply to the compressed air supply port, and a vacuum pad, etc., to the vacuum generation port.
2. In manifolds with two or more units, P ports (compressed air supply ports) are located on both ends of the manifold, and the piping direction can be selected according to the mounting location. At time of delivery, a port on one side is temporarily blocked off with a plug. Remove the plug and then use sealing tape or other sealing material to re-tighten.
3. Use a block-off plate (order code: ME□MA-BP) to block off unused stations on the manifold.
4. For piping to the micro ejector, use a nylon or urethane tube with inner diameter of $\phi 4 \sim \phi 6$ [$\phi 0.157 \sim \phi 0.236$ in.]. For vacuum generation ports, tubes of the following sizes are recommended.
ME03... $\phi 4 \times 2.5$
ME05... $\phi 4 \times 2.5, \phi 6 \times 4$
ME07... $\phi 6 \times 4$

- Cautions:**
1. Use a fitting that does not reduce inner diameter. A small inner diameter can result in degradation of performance, including pressure shortages, insufficient vacuum, or longer periods of time before the vacuum level is reached.
 2. Avoid use of coil tubes and other curved piping. Also, avoid use of elbow fittings, etc., between the micro ejector and vacuum pad, and use piping that is as straight as possible.
 3. In manifolds with many units, where a large number of micro ejectors are operating simultaneously, or where the operation frequency is very high, supply air from P ports on both ends.



Solenoid

Internal circuit

● DC12V, DC24 (surge suppression)

Standard solenoid

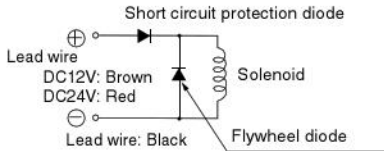

Solenoid with LED indicator

Order code: -PSL, -PLL

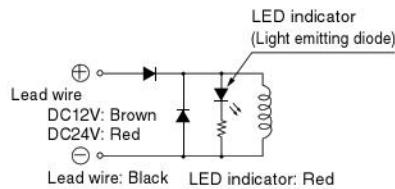

● AC100V, AC200V (surge suppression)

Standard solenoid

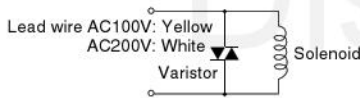

Solenoid with LED indicator

Order code: -PSL, -PLL

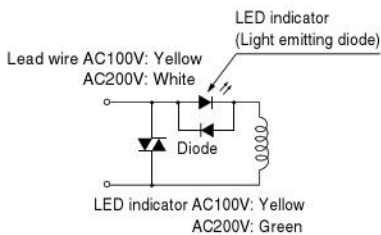

- Cautions:**
1. Do not apply megger between the lead wires.
 2. For DC12V, DC24V, while there is no danger with a solenoid of a short circuit by the wrong polarity, the valve will not operate.
 3. Leakage current inside the circuit could result in failure of the solenoid valve not to return to home position or other erratic operation. Always use within the range of the allowable leakage current. If circuit conditions, etc., cause the leakage current to exceed the maximum allowable leakage current, consult us.



Plug connector

Attaching and removing plug connector

Use fingers to insert the connector into the pin, push it in until the lever claw latches onto the protruded section on the connector housing, and complete the connection.

To remove the connector, squeeze the lever along with the connector, lift the lever claw up from the protruded section of the connector housing, and pull it out.

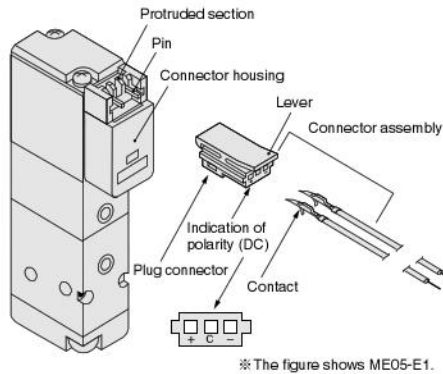

Crimping of connecting lead wire and contact

To crimp lead wires into contacts, strip off 4mm [0.16in.] of the insulation from the end of the lead wire, insert it into the contact, and crimp it. Be sure to avoid catching the insulation on the exposed wire crimping section.

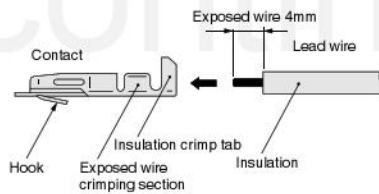

- Lead wire □ ME03 Equivalent to AWG 28
□ ME05
□ ME07 Equivalent to AWG 24

Attaching and removing contact and connector

Insert the contact with a lead wire into a plug connector □ hole until the contact hook latches on the connector and is secured to the plug connector. Confirm that the lead wire cannot be easily pulled out.

To remove it, insert a tool with a fine tip (such as a small screwdriver) into the rectangular hole on the side of the plug connector to push up on the hook, and then pull out the lead wire.

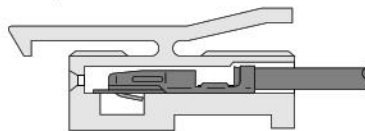

- Cautions:**
1. Do not pull hard on the lead wire. It could result in defective contacts, breaking wires, etc.
 2. If the pin is bent, use a small screwdriver, etc., to gently straighten out the pin, and then complete the connection to the plug connector.
 3. For crimping of connecting the lead wire and contact, always use a dedicated crimping tool.
Contact: Model 702062-2M
Manufactured by Sumiko Tech, Inc.
Crimping tool: Model F1-702062
Manufactured by Sumiko Tech, Inc.



Manual override

Non-locking type and locking protruding type

To operate non-locking type, use a tool with a thin tip (such as a small screwdriver) to press the manual override all the way down. The micro ejector works the same as an energized state as long as the manual override is pushed down, and returns to the reset position upon release.

To lock the locking protruding type manual override, use fingertips or a small screwdriver to push down on the manual override all the way and turn it 45 degrees or more. Either turning direction at this time is acceptable. When locked, turning the manual override from the locking position releases a spring on the manual override, returns it to its original position, and release the lock. If manual override is not turned, this type acts just like the non-locking type. The micro ejector works the same as an energized state as long as the manual override is pushed down, and returns to the reset position upon release.

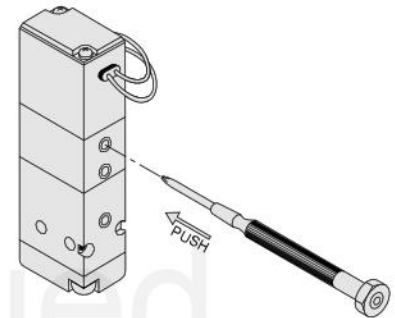

Caution: Always release the lock on the locking protruding type manual override before commencing normal operation.

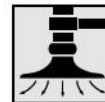

Vacuum breaking

Adjustment of vacuum breaking flow rate

Rotate the adjusting needle for vacuum breaking flow (with twin solenoid valves only) in the clockwise direction to reduce the breaking flow rate, and in the counterclockwise direction to increase the breaking flow rate.

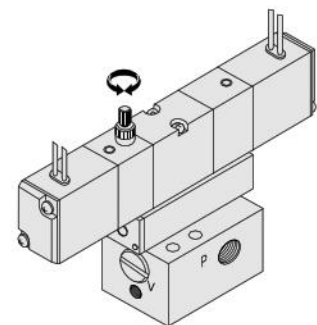

Handling Instructions and Precautions



Electronic Vacuum Switch

Pressure regulation

Rotate the pressure adjusting screw (SET) to set the pressure. Rotating the pressure adjusting screw to the right (clockwise) increases the vacuum setting. In addition, use the hysteresis adjusting screw (HYS) to set the hysteresis. Rotating the hysteresis adjusting screw to the right (clockwise) increases the hysteresis by shifting the OFF position.

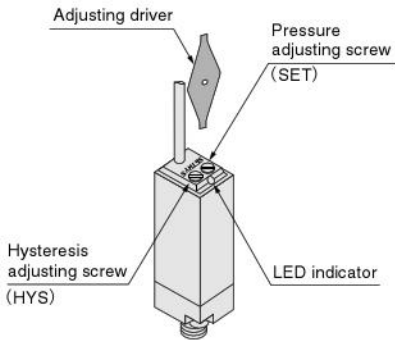

- Cautions:**
1. To set the pressure and hysteresis, use the special screwdriver provided or a small screwdriver of appropriate size, and adjust by rotating them carefully without applying excessive force.
 2. To ensure accurate pressure setting, use a pressure gauge to perform the setting while switching the vacuum switch on and off.
 3. Do not apply pressure to the pressure detection area of more than 0.2MPa [29psi].

Wiring instructions

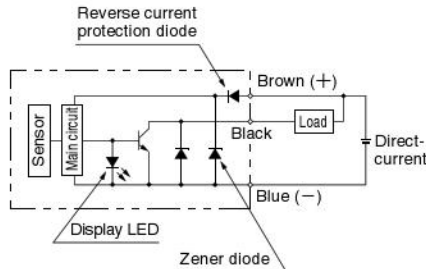

- Brown: Lead wire for connecting the (+) polarity that activates the switch
- Black: Lead wire for connecting the load
- Blue: Lead wire for connecting the (-) polarity

- Cautions:**
1. Do not subject the lead wires to strong pulling force or excessive bending.
 2. Pay attention to the lead wire colors to connect. While the lead wires between brown and blue, for connecting to the power supply, are protected by diodes for protection of reverse current, the output circuits do not have a surge current protection function. Miswiring could cause damage to the output transistor.
 3. Do not connect and use the vacuum switch with a load that exceeds its switching capacity.

Mounting

1. As subjecting the vacuum switch to strong shocks could lead to damage or erratic operation, be careful when handling it.
2. Do not apply a wrench to the body cover when mounting as a single unit (PS310E-01). When tightening, always apply the wrench to the metal part of the adapter.

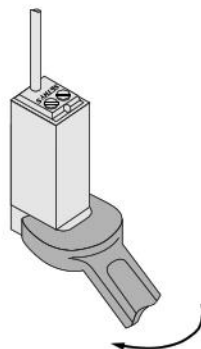

General precautions

1. If using in locations subject to dripping water, dripping oil, etc., or to large amounts of dust, use a cover to protect the unit.
2. Always thoroughly blow off (use compressed air) the piping before connecting it to the micro ejector. Intrusion into the piping of chips, sealing tape, rust, or other foreign material generated during piping operations could result in valve air leaks or a degradation in micro ejector performance.
3. Use clean air that does not contain deteriorated compressor oil or other contaminants. Install an air filter (with filtration of a minimum 40 μm) close to the micro ejector to eliminate any collected liquids or dust in air line. Always use a mist filter for cases where the pressurized air contains large amounts of oils. Moreover, drain the air filter at regular intervals.
4. Use a regulator to adjust the pressure of air supplied to the micro ejector. Where the piping length to the micro ejector is long, set the pressure at a little higher than normal. If using an air supply valve, use a valve with an effective area that is at least three times as large as the area of the micro ejector nozzle.
5. Use one vacuum pad for one micro ejector. Use of two or more pads could result in picking errors, and extend the amount of time required to reach the set vacuum level.
6. At periodic intervals, replace the filters (order code: ME□ MA-F) installed as standard equipment with the micro ejector body.

MICRO EJECTORS

ME12, ME25, ME60



Specifications

● Micro ejectors

Item	Model	ME12	ME25	ME60
Media		Air		
Operating pressure range	MPa [psi.]	0.1~0.6 [15~87]		
Operating temperature range	°C [°F]	0~50 [32~122] (No freezing)		
Nozzle diameter	mm [in.]	0.7 [0.028]	1.0 [0.039]	1.5 [0.059]
Vacuum ^{Note}	kPa [in.Hg]	-92 [-27.2]		
Vacuum flow rate ^{Note}	ℓ/min [ft ³ /min.] (ANR)	12.5 [0.441]	25 [0.88]	58 [2.05]
Compressed air consumption ^{Note}	ℓ/min [ft ³ /min.] (ANR)	23 [0.81]	46 [1.62]	107 [3.78]
Lubrication		Prohibited		
Filtration	μm	30		
Port size		Rc1/8	Rc1/4	

Note: Value is measured at air pressure of 0.5MPa [73psi.].

● Vacuum switches

Item	Operation	When NO	When NC
Setting vacuum	kPa [in.Hg]	-26.7~-80 [-7.89~-23.6]	
Response differential	kPa [in.Hg]	-5.3~-13.3 [-1.57~-3.94]	
Color of connected lead wire		Black, white	Black, red
Electric rating		5A/AC250V, 5A/DC24V (resistance load)	

Remark: For the internal switch, JIS-S2H1PO1 or equivalent is used.

● Single and twin solenoid valves

Item	Basic model	For ME12		For ME25, ME60				
		Single solenoid valve		Single solenoid valve		Twin solenoid valves ^{Note}		
		ME12E1		125EE1		125EE2		
Operation type		Direct operating		Direct operating				
Number of ports		2 ports (NC, NO)		2 ports (NC)				
Port size		Rc1/8		Rc1/4				
Proof pressure	MPa [psi.]	1.03 [149]		1.03 [149]				
Effective area	mm ² [Cv]	1.5 [0.08]		3 [0.16]				
Maximum operating frequency	Hz	5		5				
Mounting direction		Any		Any				
Voltage type		AC100V (Lead wire: yellow) AC200V (Lead wire: white) DC24V (Lead wire: red, black)		AC100V (Lead wire: yellow, black) AC200V (Lead wire: white, black) DC24V (Lead wire: red, black)				
Operating voltage range	AC100V	90~110V (100V±10%)		90~110V (100V±10%)				
	AC200V	180~220V (200V±10%)		180~220V (200V±10%)				
	DC24V	21.6~26.4V (24V±10%)		21.6~26.4V (24V±10%)				
Current	mA	Frequency	50Hz	60Hz	50Hz	60Hz	50Hz	60Hz
		AC100V	40	32	96	95	96	95
		AC200V	23	17	48	46	48	46
		DC24V	125		412		412	
Insulation resistance	MΩ	100 or more		100 or more				
Wiring		Grammet type (Lead wire length 300mm)		Grammet type (Lead wire length 300mm)				
Manual override		Locking and non-locking type		Locking type				
Surge suppression		Flywheel diode (only DC)						

Note: While there are two solenoids in the twin solenoid valves, for vacuum generation use and vacuum breaking use, the configuration prevents power from being sent to both of them at the same time.

Mass

Model	Item	Body mass	Additional mass			
			With filter	With vacuum switch	With single solenoid valve	With twin solenoid valves
ME12		40 [1.41]	25 [0.88]	—	80 [2.82]	—
ME25, 60		335 [11.82]	—	160 [5.64]	90 [3.17]	230 [8.11]

Calculation example: Mass of ME25 with a vacuum switch and twin solenoid valves is 335+160+230=725g [25.57oz.]

Order Codes

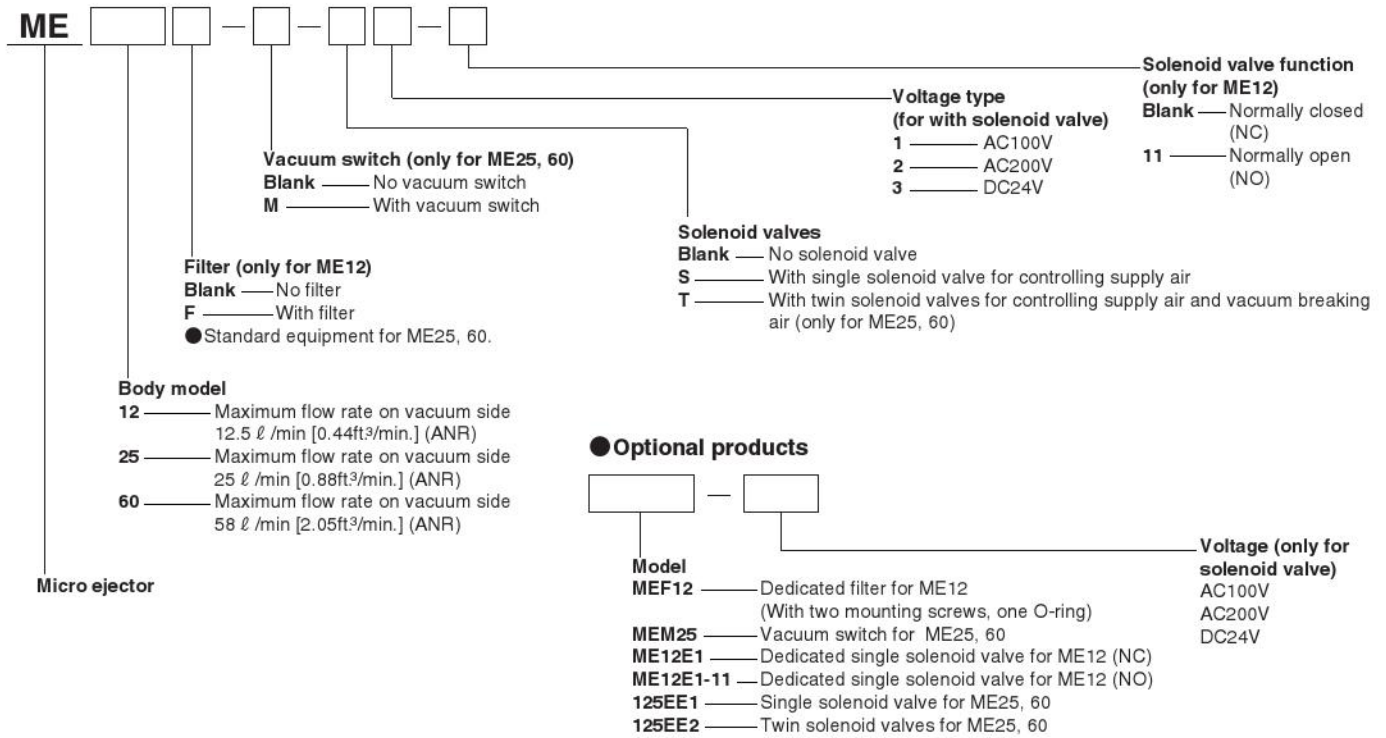

Operation Principle and Major Parts

● Not in operation

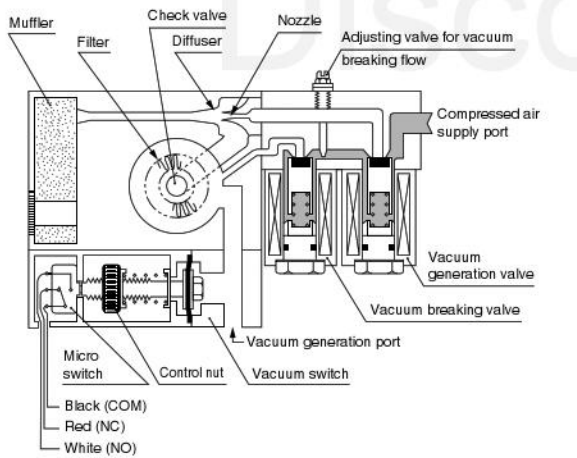
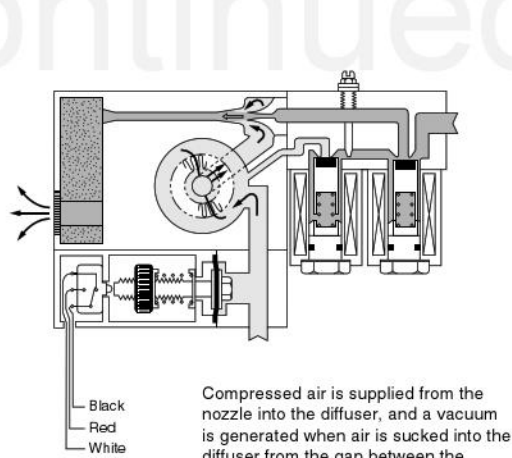

Figure shows with vacuum switch and twin solenoid valves.

● When vacuum generation valve is ON



Compressed air is supplied from the nozzle into the diffuser, and a vacuum is generated when air is sucked into the diffuser from the gap between the nozzle and the diffuser. The vacuum level rises until it exceeds the set vacuum level, causing the vacuum switch to activate.

● When vacuum breaking valve is operating

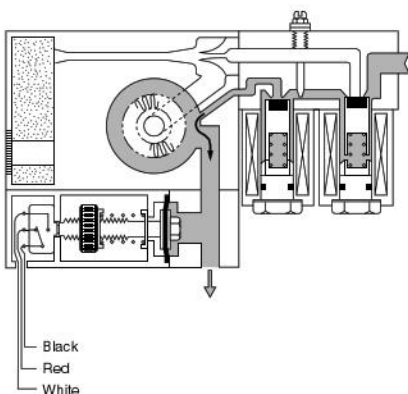

Air Consumption, Vacuum and Vacuum Flow Rate

ME12

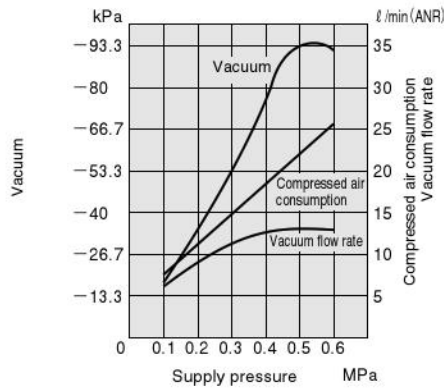

ME25

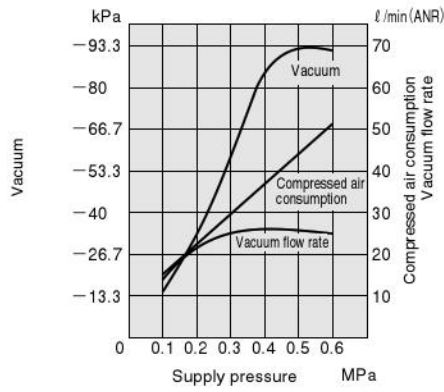

ME60

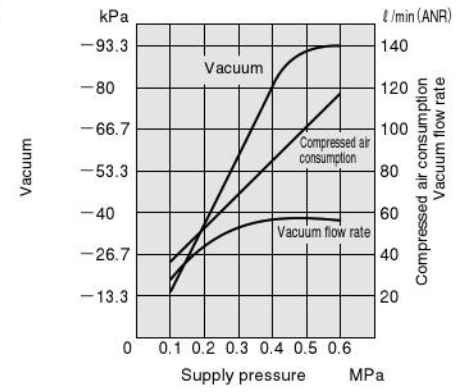

1MPa = 145psi. 1kPa = 0.145psi. -100kPa = -29.54in.Hg. 1 l/min = 0.0353ft³/min.

Symbols

Single unit

ME12

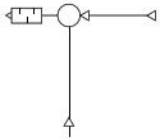

With filter

ME12F ME25 ME60

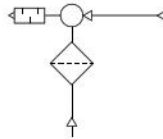

With vacuum switch and filter

ME25-M ME60-M

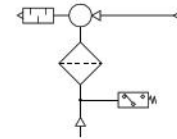

With single solenoid valve

ME12-S

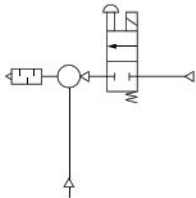

With single solenoid valve and filter

ME12F-S ME25-S ME60-S

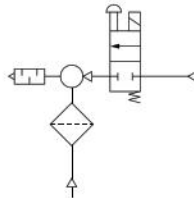

With vacuum switch, single solenoid valve, and filter

ME25-M-S ME60-M-S

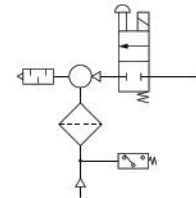

With twin solenoid valves and filter

ME25-T ME60-T

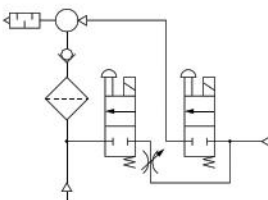

With vacuum switch, twin solenoid valves, and filter

ME25-M-T ME60-M-T

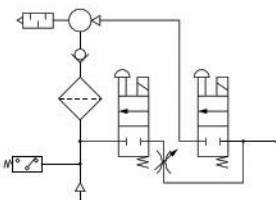

Dimensions of ME12 (mm)

●ME12

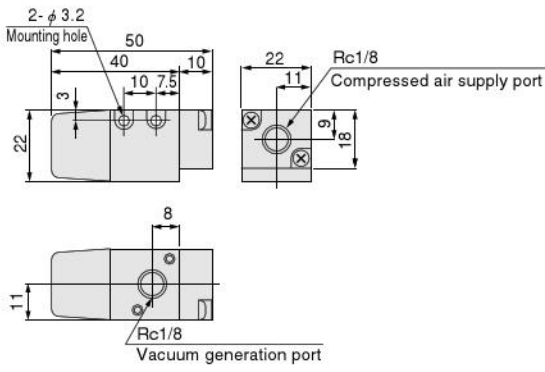

●ME12-S□

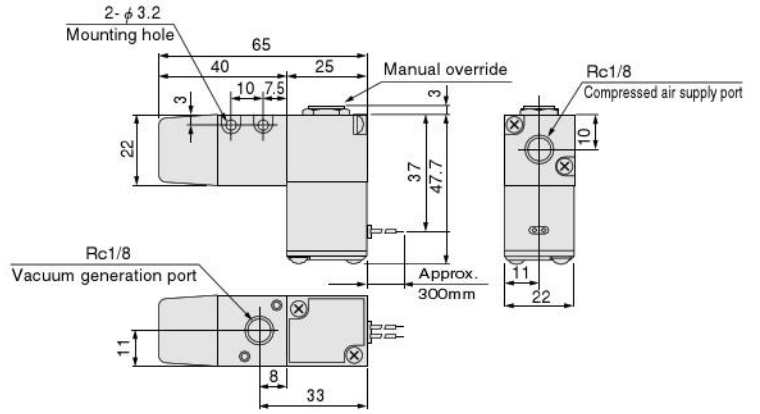

●ME12F

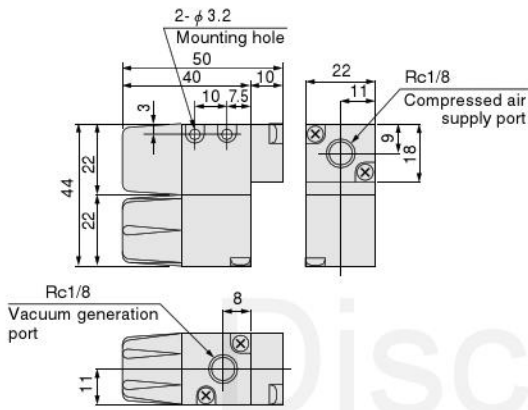

●ME12F-S□

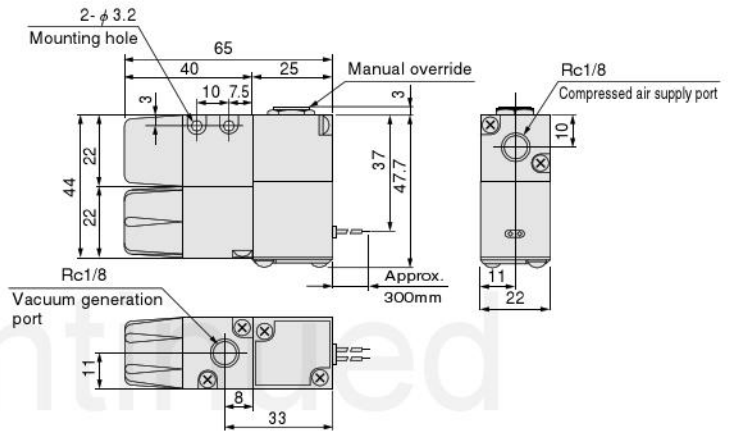

Dimensions of ME25, ME60 (mm)

- ME25
- ME60

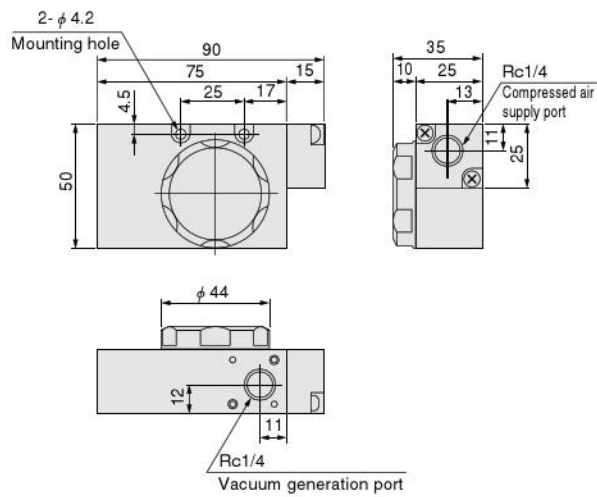

- ME25-M
- ME60-M

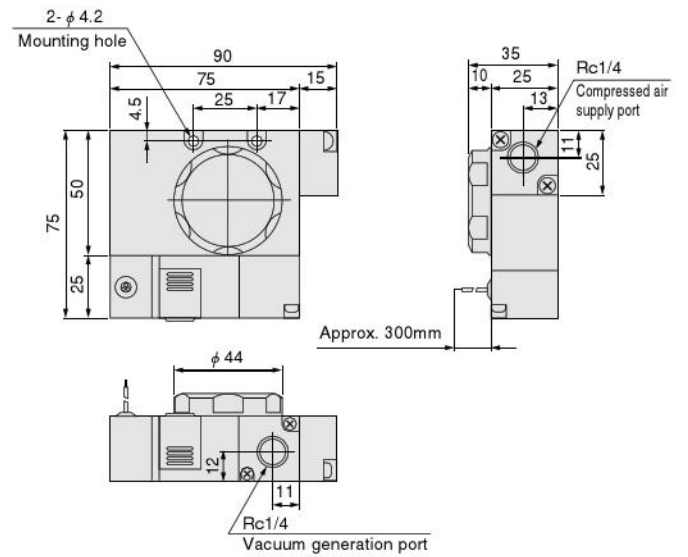

- ME25-S
- ME60-S

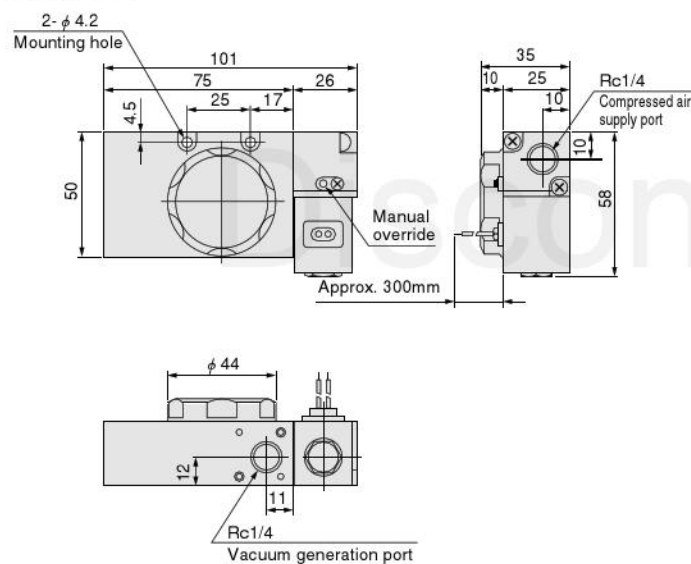

- ME25-M-S
- ME60-M-S

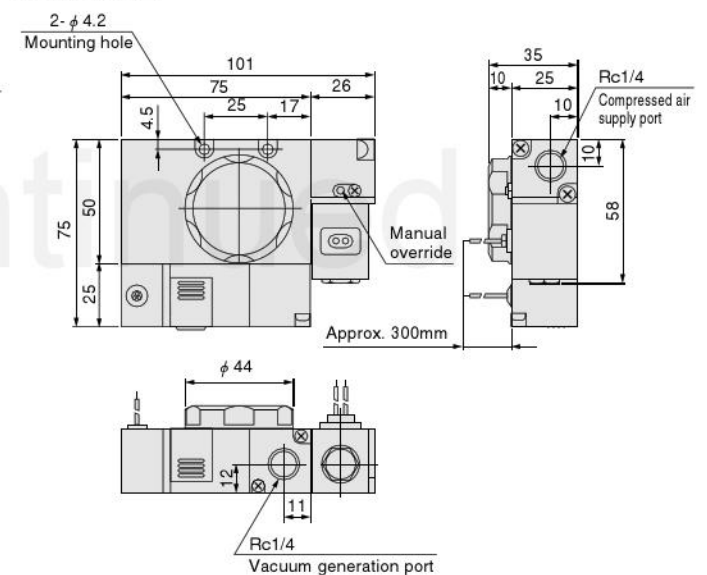

- ME25-T
- ME60-T

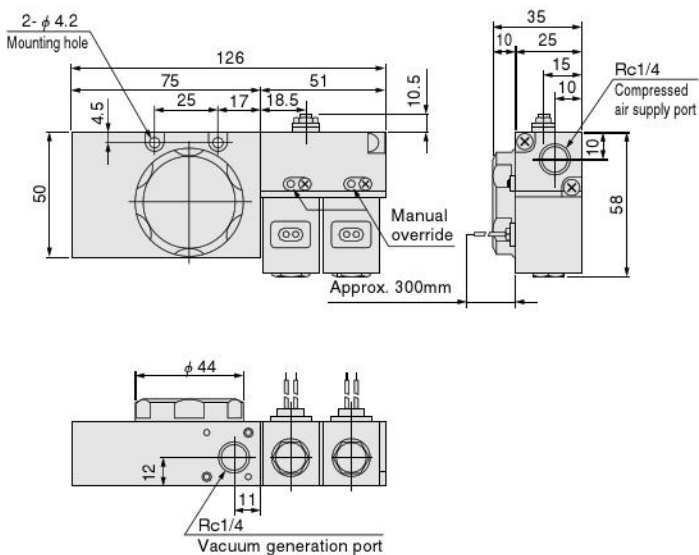

- ME25-M-T
- ME60-M-T

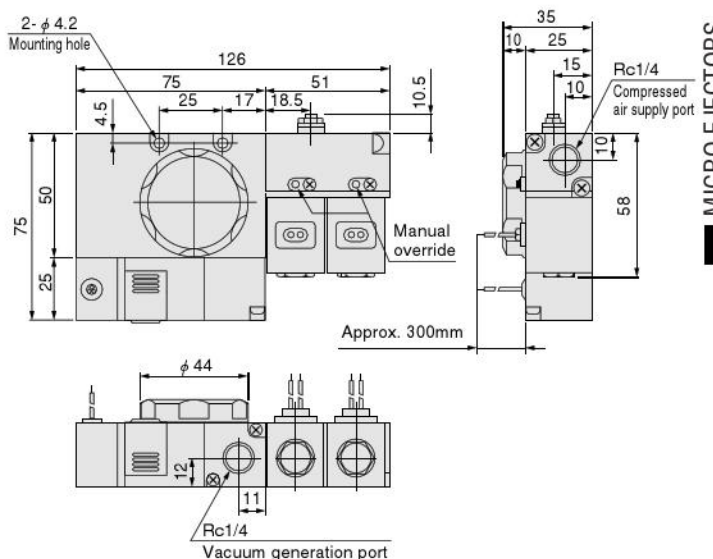



Micro ejector

Device configuration

●ME12

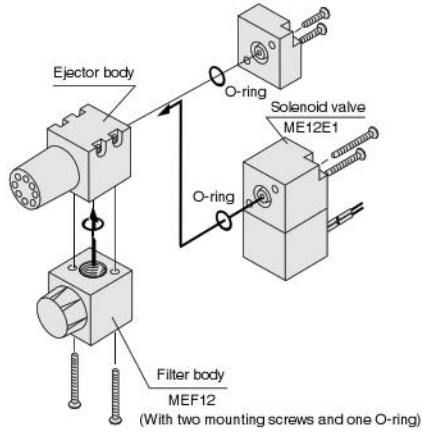

●ME25, 60

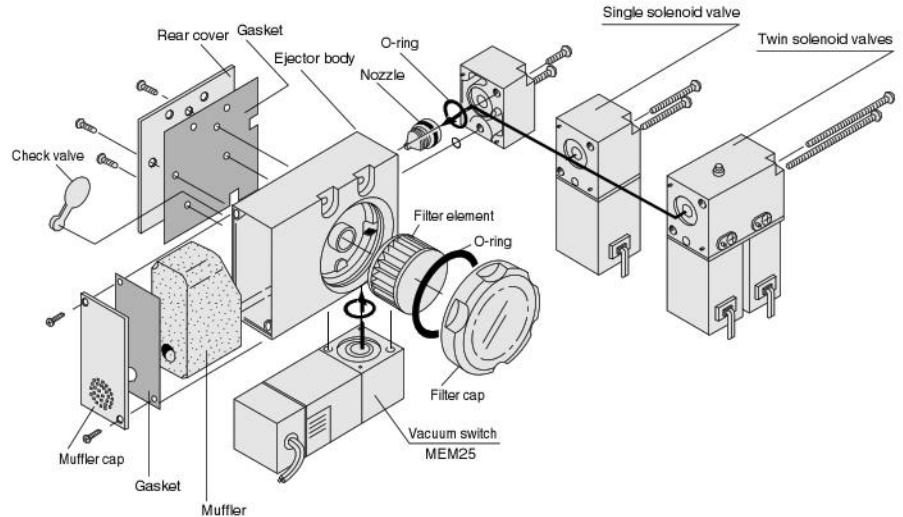

Piping

1. Connect air supply to the compressed air supply port, and a vacuum pad, etc., to the vacuum generation port.
2. For piping to the micro ejector, use a nylon or urethane tube with inner diameter of $\phi 4 \sim \phi 6$ [$\phi 0.157 \sim \phi 0.236$ in.]. For vacuum generation ports, tubes of the following sizes are recommended.

ME12	$\phi 4 \times 2.5 \sim \phi 6 \times 4$
ME25	$\phi 6 \times 4 \sim \phi 8 \times 6$
ME60	$\phi 8 \times 6 \sim \phi 10 \times 8$

- Cautions:**
1. Use a fitting that does not reduce inner diameter. A small inner diameter can result in degradation of performance, including flow rate and pressure shortages, insufficient vacuum, or longer periods of time before the vacuum level is reached.
 2. Avoid using coil tubes and other forms of spiraled piping. Also, avoid use of elbow fittings, etc., between the micro ejector and vacuum pad, and use piping that is as straight as possible.

Vacuum switch

When vacuum reaches the set vacuum level which is adjusted by a control nut, a micro switch operates, and an electrical signal is obtained. Move the cover in the direction of the arrow, and rotate the control nut to adjust the vacuum level. Rotate the control nut in the \downarrow direction to increase the set vacuum level to rise, and rotate it in the \uparrow direction to reduce the vacuum level.

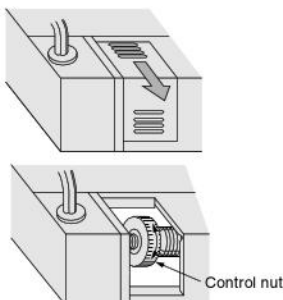

Solenoid valve

The micro ejector includes an optional single solenoid valve for vacuum generation, and optional twin solenoid valves for vacuum generation and vacuum breaking air (twin solenoid valves are for ME25 and 50 only). The twin solenoid valves option uses supply pressurized air to the vacuum side to enable vacuum breaking and blow-off release, and makes use of a breaking flow adjustment valve to allow flexible setting of breaking and release time. In addition, a built-in check valve ensures that the vacuum level setting can be maintained even when the power to the vacuum generation solenoid valve has been switched off, enabling energy savings.

● Energy-saving circuit for maintaining vacuum over long periods

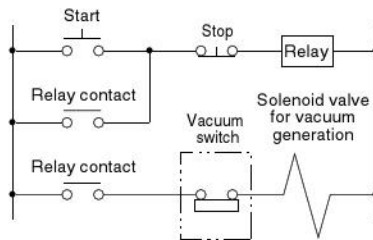

● Solenoid internal circuit

ME12

DC24V (surge suppression)

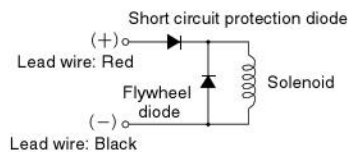

AC100V, AC200V (shading type)

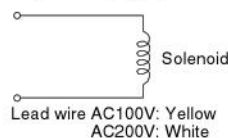

ME25, ME60

For DC and AC (DC surge suppression)

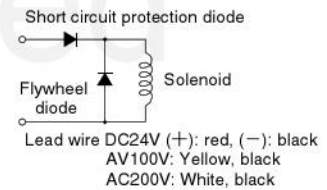

- Cautions:**
1. Do not apply megger between the lead wires.
 2. The DC solenoid will not short circuit even if the wrong polarity is applied, but the valve will not operate.
 3. Leakage current inside the circuit could result in failure of the solenoid valve to return, or other erratic operation. Always use it within the range of the allowable leakage current. If circuit conditions, etc., cause the leakage current to exceed the maximum allowable leakage current, consult us.

● Adjustment of breaking flow rate

Rotate the adjusting needle for vacuum breaking flow rate in the clockwise direction to reduce the vacuum breaking flow rate and lengthen vacuum breaking time, and in the counterclockwise direction to increase the vacuum breaking flow rate and shorten breaking time.

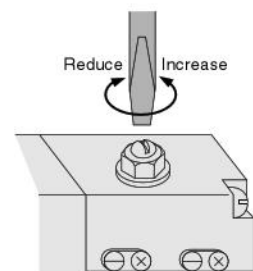

Time to Reach Vacuum and Vacuum Breaking Time

● Measurement circuits and conditions

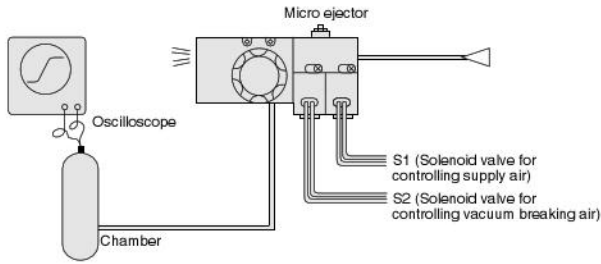

● Measurement method

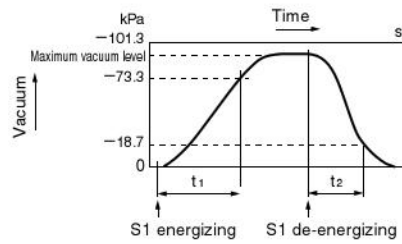

Air pressure: 0.5MPa [73psi.]
 t1: Time to reach -73.3kPa [-21.65in.Hg] in the chamber after energizing S1.
 t2: Time to reach -18.7kPa [-5.52in.Hg] in the chamber after energizing S2.

● Response time

Chamber capacity cm^3 [in ³]	S											
	10 [0.610]		50 [3.05]		200 [12.2]		1000 [61.0]		3000 [183]		5000 [305]	
Model	Time		t ₁	t ₂	t ₁	t ₂	t ₁	t ₂	t ₁	t ₂	t ₁	t ₂
ME12	1.5	—	2.0	—	4.0	—	7.5	—	26.0	—	50.0	—
ME25	1.0	0.1	1.3	0.1	2.0	0.2	3.8	0.4	13.0	1.5	23.0	3.0
ME60	0.5	0.1	1.0	0.1	1.5	0.2	3.0	0.4	10.0	1.5	15.0	3.0

Note: Some degree of variation may occur due to piping size and chamber shape.
 The figures can be viewed as a guide.

● Manual operation

ME12E1

To lock the manual override, use a small screwdriver to push down the manual override all the way and turn it 45 degrees or more. Either turning direction at this time is acceptable. When locked, turning the manual override from the locking position releases a spring on the manual override, returns it to its original position, and release the lock.

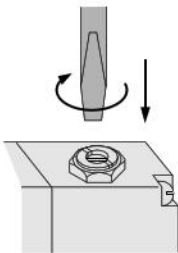

125EE1, 125EE2

To lock, use a screwdriver to rotate the manual override 45 degrees and tilt the screw groove 45 degrees. Either turning direction at this time is acceptable. To release the lock, rotate the manual override by 45 degrees, and return the screw groove to horizontal.

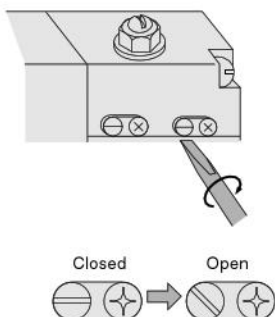

Caution: Always release the lock on the manual override before commencing normal operation.

continued

Discontinued