

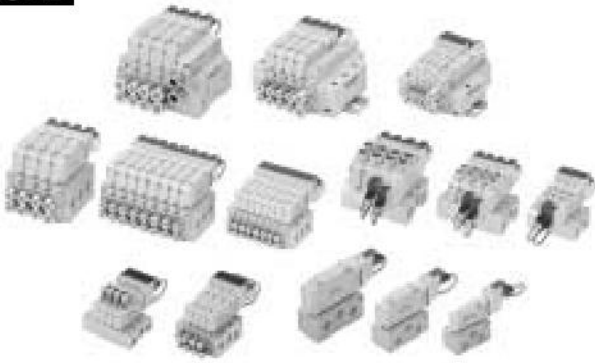

Presenting our CAD drawing
data catalog



KOGANEI

VALVES GENERAL CATALOG

SOLENOID VALVES

GF SERIES

INDEX

Characteristics	434
Variations	436
Table of Cylinder Operating Speed	438
Handling Instructions and Precautions	439
Manifold Disassembly Diagram, Unit Adding Procedure	443
Operating Principle, and Symbol	445
Order Code	447
Solenoid Valves GF10 Series	461
Specifications	462
Dimensions	465
Solenoid Valves GF15 Series	473
Specifications	474
Dimensions	477
Solenoid Valves GF18 Series	485
Specifications	486
Dimensions	489
GF Series Specifications Confirmation Form	497

Discontinued

New valves, further improving user friendlier operability.

GF SERIES SOLENOID VALVES

The GF series solenoid valves inherit the development concept of the F series solenoid valves to achieve easy operability even further in the single valve range. While mounting the same compact, large flow capacity valves as the F series, the GF series achieves the low power consumption of 0.5W (DC24V), and also adds AC200V specifications to the product range. It also offers excellent assembly and maintenance ability for monoblock manifolds (base piping, direct piping) in a confined space. It is the “Best Price & Global Model” equipped with simple but basic functions.

1. More compact, and larger flow rate

Flow rate up by 2~3. 3 times with the same valve width (Koganei company comparison).

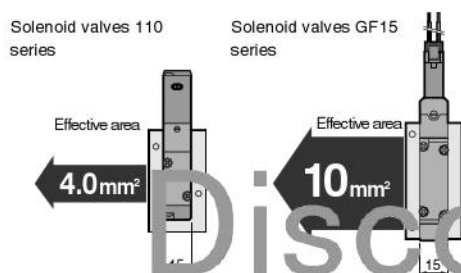

External pilot specification

External pilot (positive pressure) specification allows the main pressure to operate from 0 MPa. Vacuum specification can also be selected.



2. A higher level of easy operation

- By replacing the output blocks for base piping with the direct piping version offers fast change of the valve piping.
(Except monoblock manifold F type, monoblock compact manifold A type and F type)

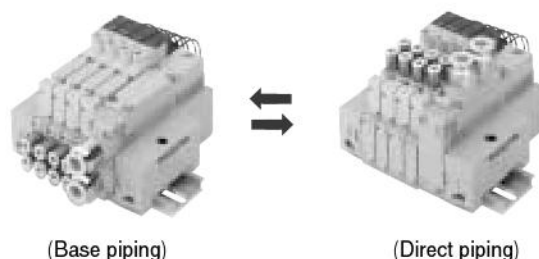

- Female thread block and fitting blocks can be selected.

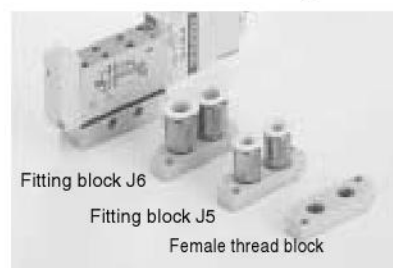

Fitting block tube size

Model		J5	J6
Series			
	GF10	φ 4	φ 6
	GF15	φ 6	φ 8
	GF18	φ 8	φ 10

3. Archives power consumption of 0.5W (current 21mA, DC24V)

※Power consumption per one valve (for DC24V specification)

- Offers individual air supply and exhaust.
Placing dedicated air supply or exhaust spacers between the manifold and valve offers individual air supply or exhaust.



GF 10

SOLENOID VALVES GF10 SERIES

- Valve width: 10mm
- Effective area: 5mm²
- Applicable cylinder bore sizes: $\phi 20 \sim \phi 50$

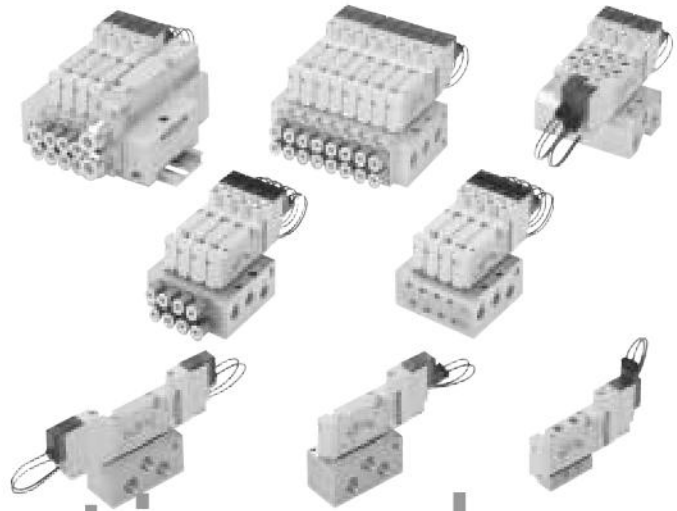

Discontinued

GF 15

SOLENOID VALVES GF15 SERIES

- Valve width: 15mm
- Effective area: 10mm²
- Applicable cylinder bore sizes: $\phi 40 \sim \phi 80$

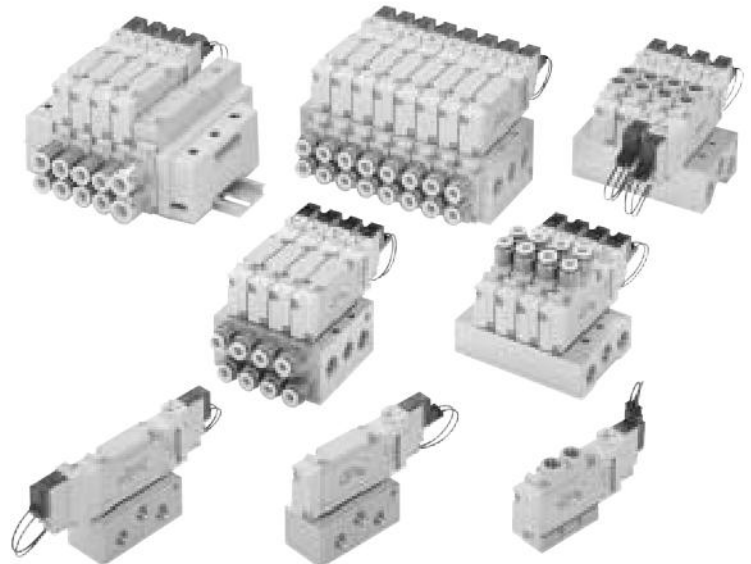

GF 18

SOLENOID VALVES GF18 SERIES

- Valve width: 18mm
- Effective area: 18mm²
- Applicable cylinder bore sizes: $\phi 50 \sim \phi 100$

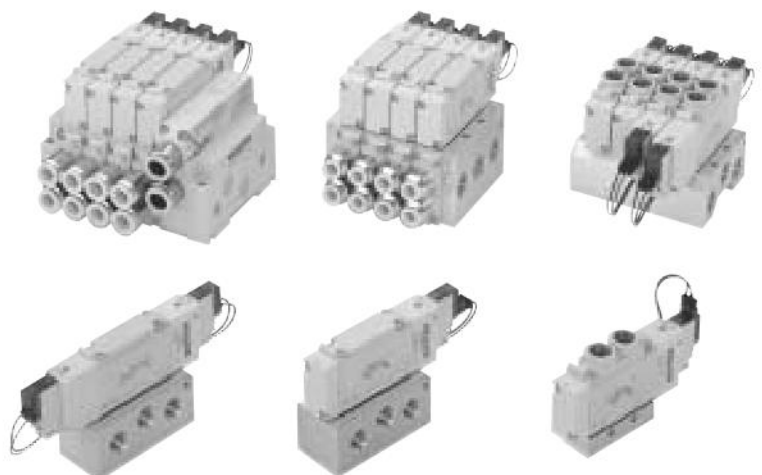

Single Valve Unit

Valves can be used as a single unit by attaching an input port block. Mounting brackets are also provided.

Discontinued

Output port specifications

Series	With sub-base		For single unit or manifold						
	Female thread		With female thread block			With fitting block			
	Rc 1/8	Rc 1/4	M5	Rc 1/8	Rc 1/4	φ 4	φ 6	φ 8	φ 10
GF 10	●		●			●	●		
GF 15	●			●			●	●	
GF 18		●			●			●	●

Order code p. 448,449

GF10 series dimensions p. 465

GF15 series dimensions p. 477

GF18 series dimensions p. 489

With fitting block



※ Illustration shows the GF10 series

With female thread block



With A type sub-base



With mounting bracket

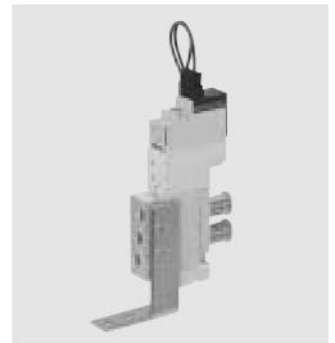

2-position single solenoid

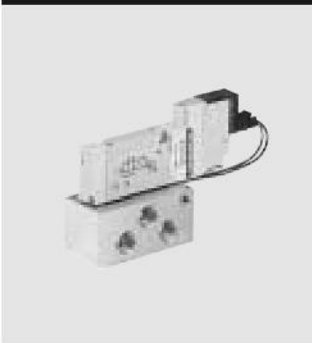

2-position double solenoid



3-position double solenoid



※ Photos show GF10 series with A type sub-base.

Monoblock Manifold A Type (Base Piping Type)

This base piping type manifold achieves in both maintenance and cost performance.

By replacing the output block, also it can be used as a direct piping type.

With fitting block

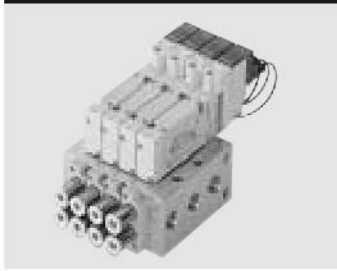

With female thread block

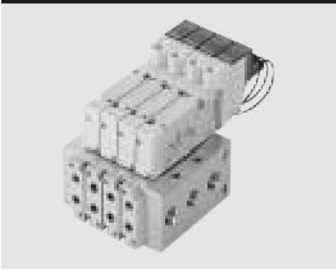

Order code p. 450,451

GF10 series dimensions p. 469

GF15 series dimensions p. 481

GF18 series dimensions p. 493

Monoblock Compact Manifold A Type (Base Piping Type)

Manifold for base piping type achieves low height.

Fitting specification



Female thread specification



Order code p. 452,453

GF10 series dimensions p. 470

GF15 series dimensions p. 482

Discontinued

Monoblock Manifold F Type (Direct Piping Type)

Manifold for direct piping type achieves excellent cost performance.

With fitting block



With female thread block



Order code p. 454,455

GF10 series dimensions p. 469

GF15 series dimensions p. 481

GF18 series dimensions p. 493

Monoblock Compact Manifold F Type (Direct Piping Type)

Manifold for direct piping type achieves low height.

With fitting block



With female thread block



Order code p. 456,457

GF10 series dimensions p. 470

GF15 series dimensions p. 482

Split Manifold Non-Plug-in Type

Allows easy addition or removal of the manifolds stations. This system offers more flexibility in responding to changes in specifications.

With manifold port fitting block



With valve port fitting block



With manifold port female thread block



With valve port female thread block



Order code p. 458,459

GF10 series dimensions p. 471

GF15 series dimensions p. 483

GF18 series dimensions p. 494

Table of Cylinder Operating Speed (Reference)

1. Cylinder mounting direction: vertical

Series	Cylinder speed mm/s	Cylinder series/Conditions/Cylinder bore size mm									
		NEW Pen Cylinder Series		Slim Cylinder Series				NEW DYNA Cylinder Series			
		Pressure: 0.5MPa Load ratio: 50% Cylinder stroke: 150mm Piping (outer diameter × inner diameter × length): φ 6 × φ 4 × 1000mm		Pressure: 0.5MPa Load ratio: 50% Cylinder stroke: 150mm Piping (outer diameter × inner diameter × length): φ 6 × φ 4 × 1000mm				Pressure: 0.5MPa Load ratio: 50% Cylinder stroke: 150mm Piping (outer diameter × inner diameter × length): φ 10 × φ 7.5 × 1000mm			
		10	16	20	25	32	40	50	63	80	100
GF10 series Effective area 5mm ²	150	※									
	300										
	450		※					★			
	600										
GF15 series Effective area 10mm ²	150	※									
	300										
	450		※					★	★		
	600										
GF18 series Effective area 18mm ²	150	※									
	300										
	450		※					★	★	★	
	600										
	750			★							

★: Use each cylinder type within their operating speed ranges.

※: Cylinder speed is restricted by the piping port orifice size.

Remark: For load ratio of other than 50%, see the "Cylinder Operating Speed" in the lists of specifications for each valve.

Discontinued

2. Cylinder mounting direction: horizontal (Roller bearing: Friction coefficient μ=0.1)

Series	Cylinder speed mm/s	Cylinder series/Conditions/Cylinder bore size mm									
		NEW Pen Cylinder Series		Slim Cylinder Series				NEW DYNA Cylinder Series			
		Pressure: 0.5MPa Load ratio: 50% Cylinder stroke: 150mm Piping (outer diameter × inner diameter × length): φ 6 × φ 4 × 1000mm		Pressure: 0.5MPa Load ratio: 50% Cylinder stroke: 150mm Piping (outer diameter × inner diameter × length): φ 6 × φ 4 × 1000mm				Pressure: 0.5MPa Load ratio: 50% Cylinder stroke: 150mm Piping (outer diameter × inner diameter × length): φ 10 × φ 7.5 × 1000mm			
		10	16	20	25	32	40	50	63	80	100
GF10 series Effective area 5mm ²	150										
	300	※									
	450		※					★			
	600										
GF15 series Effective area 10mm ²	150										
	300	※									
	450		※					★	★		
	600										
GF18 series Effective area 18mm ²	150	※									
	300	※									
	450		※					★	★	★	
	600										
	750			★	★	★	★				

★: Use each cylinder type within their operating speed ranges.

※: Cylinder speed is restricted by the piping port orifice size.

Remark: For load ratio of other than 50%, see the "Cylinder Operating Speed" in the lists of specifications for each valve.



Solenoid

Internal circuit

● DC12V, DC24V

Solenoid with LED Indicator (surge suppression)

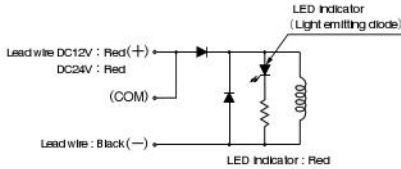

● AC100V, AC200V

Solenoid with LED Indicator (surge suppression)

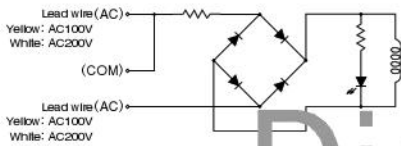

- Cautions:**
1. Do not apply megger between the lead wires.
 2. While there is no danger with a DC solenoid of a short circuit due to the wrong polarity, the valve will not operate.
 3. Leakage current inside the circuit could result in failure of the solenoid valve to return or in other erratic operation. Always use within the range of the allowable leakage current. If circuit conditions, etc., cause the leakage current to exceed the maximum allowable leakage current, consult us.
 4. For double solenoid, avoid energizing both solenoids simultaneously. The valve could fall into a neutral state.



Plug connector

Attaching and removing plug connector

Use fingers to insert the connector into the pin, push in until the lever claw catches on the convex section on the connector housing, and complete the connection. To remove the connector, squeeze the lever along with the connector, lift the lever claw up from the convex section on the connector housing, and pull out.

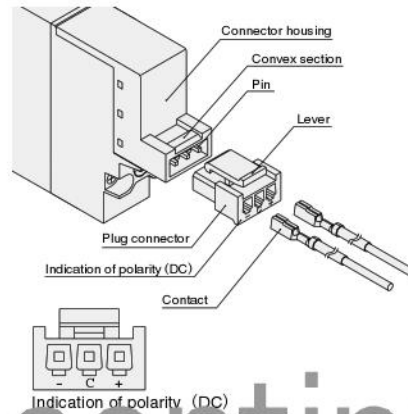

Crimping of connecting lead wire and contact

To crimp lead wires into contacts, strip off 4mm of the insulation from the end of the lead wire, insert it into the contact, and bend down crimp holds. Be sure to avoid catching the insulation on the expose wire crimping section.

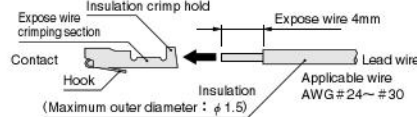

- Cautions:**
1. Do not pull hard on the lead wire.
 2. Always use the dedicated tool for crimping of connecting lead wire and contact.
Contact: Model 706312-2MK
Manufactured by Sumiko Tech, Inc.
Crimping tool: Model F1 (for 706312 2MK)
Manufactured by Sumiko Tech, Inc.

Attaching and removing contact and connector

Insert the contact with lead wire into a plug connector hole until the contact hook catches and is secured to the plug connector. Confirm that the lead wire cannot be easily pulled out. To remove, insert a tool with a fine tip (such as a small screwdriver) into the rectangular hole on the bottom of the plug connector to push up on the hook, and then pull out the lead wire.

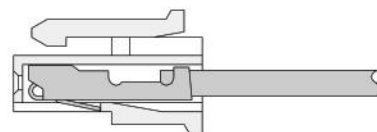

- Cautions:**
1. Do not pull hard on the lead wire. It could result in defective contacts, breaking wires, etc.
 2. If the pin is bent, use a small screwdriver, etc., to gently straighten out the pin, and then complete the connection to the plug connector.
 3. For crimping of connecting lead wire and contact, always use a dedicated crimping tool. If a crimping tool is required, consult us.



Manual override

Manual override (Blank: Locking type, -80: Non-locking type)

To lock in the locking type, use a small screwdriver to push down on the manual override all the way and turn it clockwise 90 degrees. When locked, turning the manual override 90 degrees in a counterclockwise direction releases a spring on the manual override, returns it to the original position, and releases the lock. If the manual override is never turned, this type acts just like the non-locking type, like the valve energizing status as long as the manual override is pushed down, and returning to the rest position upon release.

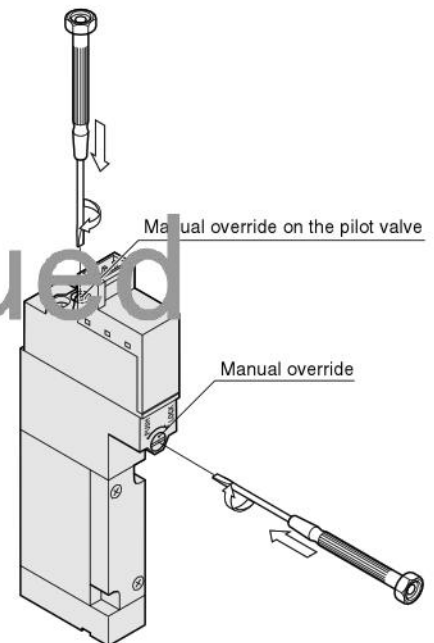

- Cautions:**
1. While manual override operation is also possible on the pilot valve, be sure to always release the lock after completing the manual override operation. Moreover, always check on before valve operation to confirm that the lock on the pilot valve has been released.
 2. The GF series are pilot type solenoid valves. As a result, the manual override cannot switch the main valve without supplying air from the P port.
 3. Always release the lock on the locking type before commencing normal operation.
 4. Do not attempt to operate the manual override with a pin or other object having an extremely fine tip. It could damage the manual override button.



Valve function

3-port valves

When using a 5-port valve as a 3-port valve

In the GF10, GF15 and GF18 series, plug one of the output ports (A or B) enabling to use as a normally closed (NC) or normally open (NO) 3-port valve. In this case, use the exhaust ports (R1 and R2) in the opening status. This can also be applied to a double solenoid type 3-port valve.

Plug position	Plug the B port	Plug the A port
Switching type	Normally closed (NC)	Normally open (NO)
Single solenoid		
Double solenoid		

Discontinued



Manifold

Attaching and removing valves

To remove the valve body from the sub-base or manifold, loosen the valve mounting screws (2 places), and lift up in the direction of the arrows (see diagram at right). For mounting, conduct the same procedure in reverse. The recommended tightening torques for the valve mounting screws are as shown below.

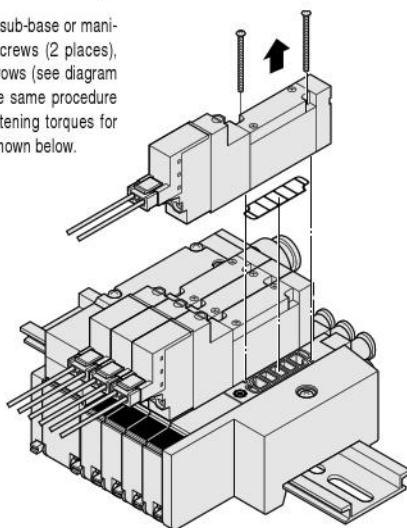

※:Illustration shows the GF10 series. (split manifold)

Series	Recommended tightening torque
GF10	17.6 {1.8}
GF15	49.0 {5.0}
GF18	49.0 {5.0}

N · cm {kgf · cm}

Split

In the split type manifold, fitting splits to the P and R ports between each of the stations isolates the air path between the station installed with splits and stations with smaller numbered stations. Note, however, that a piping block must be placed on both ends.

- Split for the P port (Model : F□Z-SP) — Can supply two different kinds of pressure.
- Split for the R port (Model : F□Z-SR) — Can isolate exhaust air. (prevents exhaust interference)
- Split for the P and R ports (Model : F□Z-SA) — Can supply two different kinds of pressure, and can isolate the exhaust air. (prevents exhaust interference)

※□ shows the valve size.

[GF10, GF15 series]

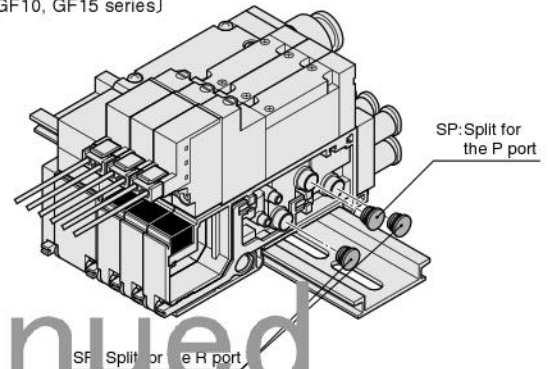

[GF18 series]

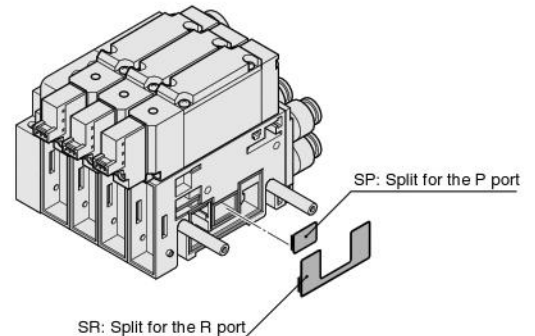

Caution:Mounting splits requires the disassembly and re-assembly of the manifolds. See the disassembly diagram, unit adding procedure, and cautions found on p. 443-444.

Precautions for using manifold

Observe the following precautions when using the split type manifold (excluding the monoblock manifold)

- When using the direct piping type
Avoid using valve at an operating frequency exceeding 2Hz, as such application can result in heat-related breakdowns.
- When using the base piping type
When plugs have been inserted into either or both of the A and B ports, avoid using valve at an operating frequency exceeding 2Hz, as such application can result in heat-related breakdowns.



Fitting

Piping

1. Procedure for replacing the base piping type and the direct piping type

Base piping and direct piping replacement can be done by replacing the plate with a fitting block or a female thread block. (see **Figure 1**).

※ Except monoblock manifold F type, monoblock compact manifold A type and F type

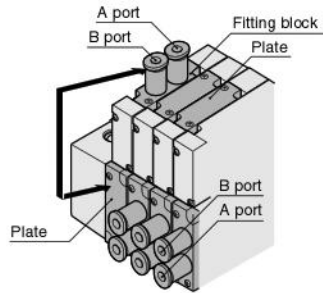

※ Illustration shows the GF10 series.
[Figure 1]

- Cautions:**
1. Firmly tighten the screws after completing a replacement.
 2. Perform piping carefully in regards to the positions of each connection port (see **Figures 2, 3**).
 3. Be careful about losing the gaskets while replacing plate and fitting block.

● Direct piping type

For the **GF10, GF15** series

For the **GF18** series

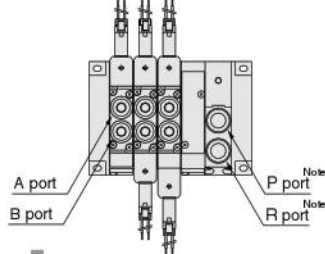
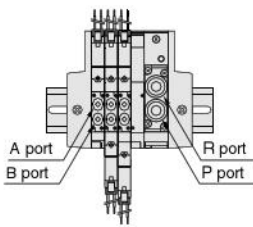

※ Illustration shows the GF10 series.

Note: Be aware that the locations of the P and R ports are reversed from the positions in the GF10, GF15 series.

[Figure 2]

● Base piping type

Port locations of **GF10, GF15, GF18** series are as shown in **Figure 3**.

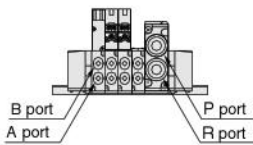

※ Illustration shows the GF10 series.

[Figure 3]

2. Attaching fittings to female thread blocks

When attaching fittings to female thread blocks, tighten within the tightening torques shown below.

Thread size	Tightening torque N·cm {kgf·cm}
Rc 1/8	686 {70}
Rc 1/4	882 {90}

※ For M5, tighten at the torques recommended for the fittings.

3. Attaching fittings to piping blocks [GF18Z(G)-PM]

To attach fittings to the female thread type piping block of the GF18 series, remove the piping block section (the triangular-shaped block section), apply a spanner to the metallic sections of both the P and R ports to fix them in place, and then thread in the fittings. The tightening torque for the mountings (two M3 screws) on the piping block section after the fittings have been attached should be 49.0 N·cm {5.0kgf·cm}.

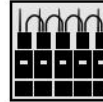

Lead wire for common wiring

Using the lead wire for common wiring, provided as additional parts, saves on wiring work.

Lead wire for common wiring

- **-PS, -PL, -PS3, -PL3** (set of 10 pieces)



● DC plus side and AC common terminal wiring example

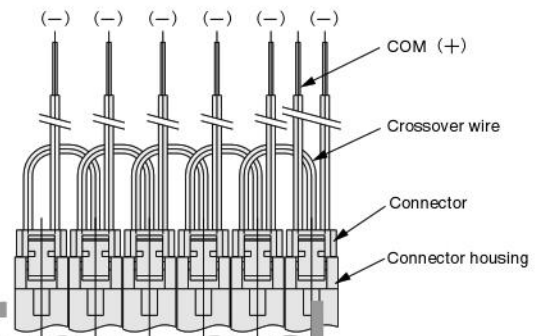

Note: The diagram shows straight connector configuration.

Discontinued

Precautions for use of individual air supply and exhaust spacers

In valve specification **T1**, mounting an individual air supply or exhaust spacer on the manifold allows for isolating air supply or exhaust. Note that when spacers are used, the effective area is reduced by about 30%. If mounting additional spacers to an existing unit, observe the following items.

● Spacer mounting procedure (Valve specification T1 only)

- ① Loosen the valve mounting screws for the installation of individual air supply or exhaust spacer, and remove the valve.
- ② Attach the gaskets and exhaust valve provided with the individual air supply or exhaust spacer, use the mounting screws provided to mount the valve on the manifold. (See Figs. 4 and 5) For the recommended torque of the valve mounting screws, see p. 440.

Remark: If attach fittings to the GF10 spacer, use the recommended fittings shown below.

TSH4-M5M, TSH4-M5, TSH6-M5M, TS4-M50, TS4-M5M

Caution: Locations where the spacers are mounted make the valve height higher by the height of the spacer. (See dimensions at right)

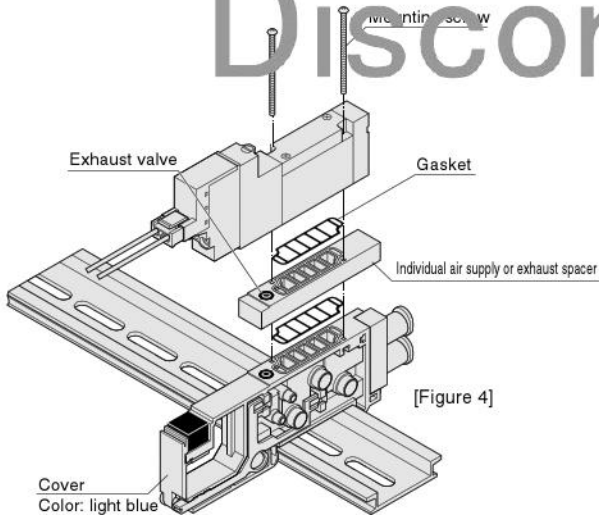

GF10, 15 series

(Illustration shows the split manifold non plug-in type)

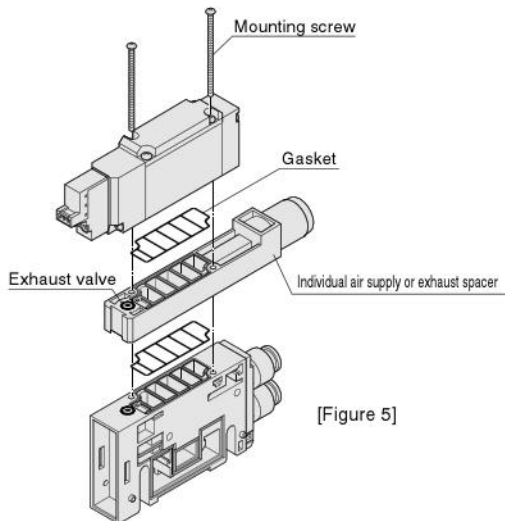

GF18 series

(Illustration shows the split manifold non-plug-in type)

● Muffler for individual exhaust spacer

A muffler for the individual exhaust spacer is available.

For the outward appearance diagrams, see p.472, 484, and 495.

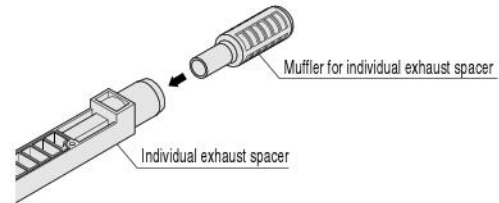

● Dimensions

F10Z-N□□ (For GF10 series) Mass 7g

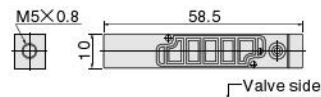

F15Z-N□□ (For GF15 series) mass 26g

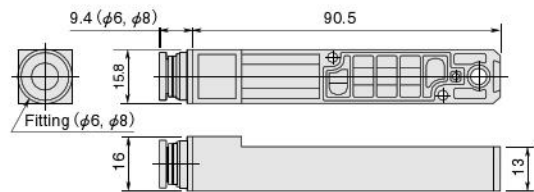

F18Z-N□□ (For GF18 series) Mass 41g

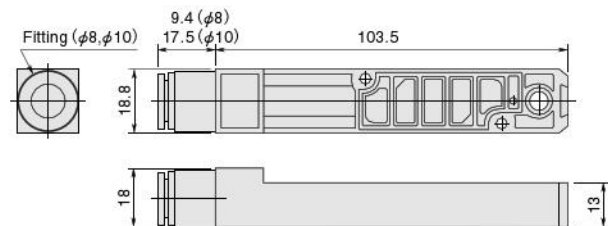

GF10, 15 Series Disassembly Diagram of Split Manifold Non-Plug-in Type

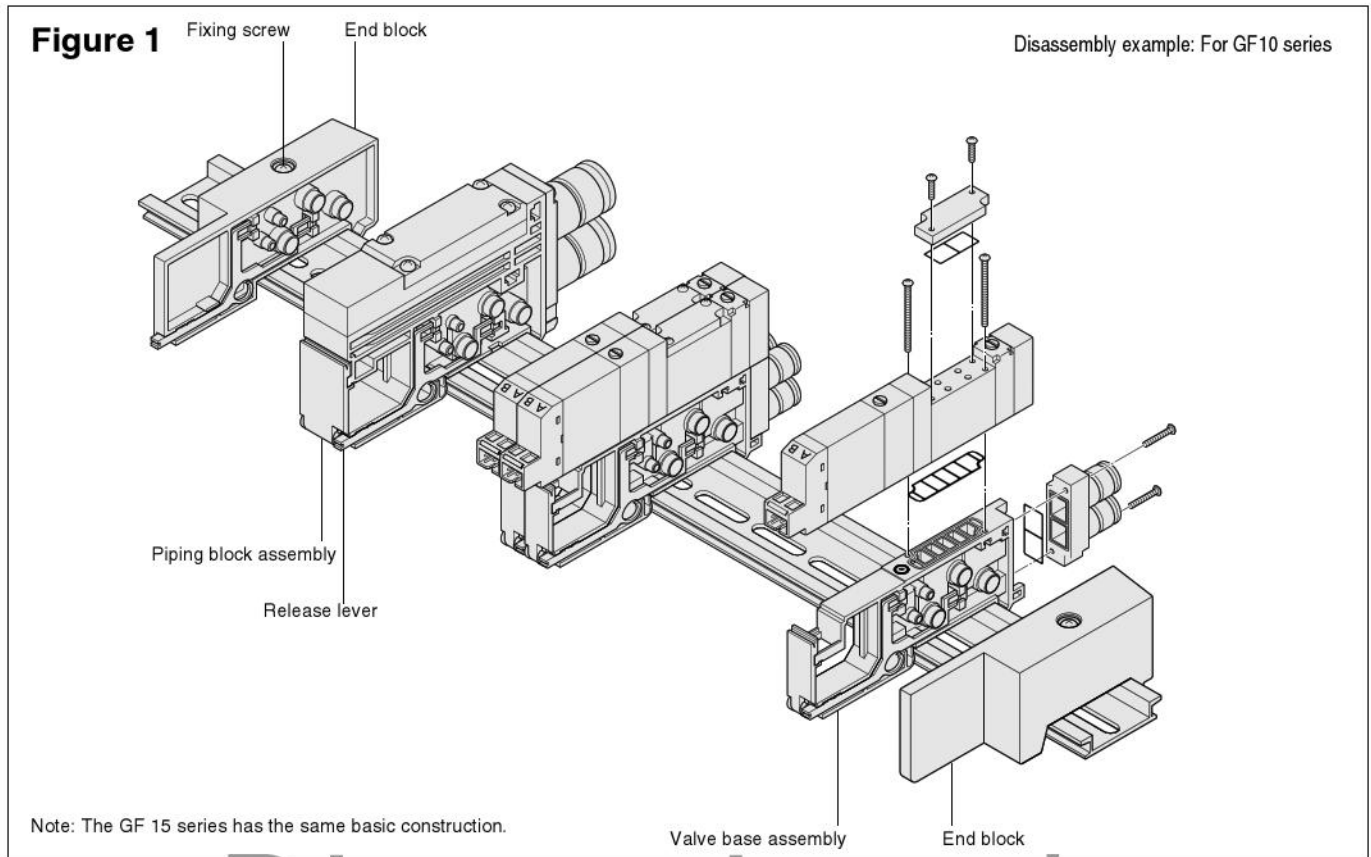

Manifold Unit Adding Procedure (GF10, GF15 Series Non Plug-in Type)

■ Adding valve base unit

Use the valve base assembly to add units.

- ① Loosen the fixing screw on the end block until the end block can slide (see Figure 1).
Note: For the G15 series, loosen the fixing screws on both left and right end blocks (three screws in each).
 - ② Press the release lever on the valve base assembly where the new unit is to be added, and disconnect the link between the bases.
 - ③ Mount the valve base assembly to be added on the DIN rail shown in Figure 2.
 - ④ Return the release lever of the valve base assembly disassembled in Step ② to its original position, as shown in Figure 3. In addition, set the release lever for the valve assembly being added to the same position, then press the valve bases together until they connect and click into place.
 - ⑤ Press the bases together from both sides to ensure that there is no clearance between them, and then tighten the fixed screws on the end block, and fix the units in place on the DIN rail (see Figure 5). Tightening torque : 98N·cm {10kgf·cm}
- Notes: 1. Always follow the steps shown in Figure 4 when tightening the end block fixing screws for the GF15 series.
2. Confirm that the DIN rail mounting bracket's hooks are securely attached to the DIN rail. (see Figure 5).

[Caution]

- Always cut off the power and air supply before working. In addition, always confirm that air has been completely exhausted from the manifold.
- Be careful not to get caught or lose the gaskets.
- Before supplying air to the manifold, always confirm that the bases are connected, the end block fixing screws are tightened, etc. Supplying air when either of the end blocks is not securely fixed on the DIN rail could result in air leaks or in separated manifold bases.
- When there are large number of valves simultaneously supplying air to the secondary side, or when there is a large number of valve units, we recommend to use two sources of air supply and exhaust (on each side).

Note that adding units to the piping block assembly is performed in the same way as adding units to the valve base assembly.

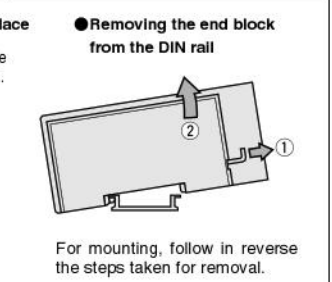
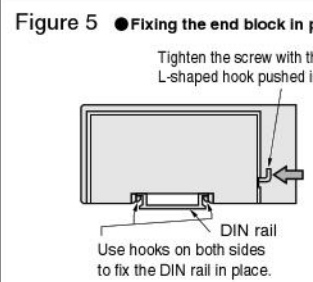
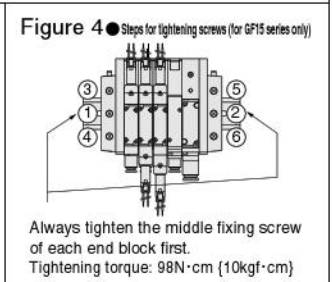
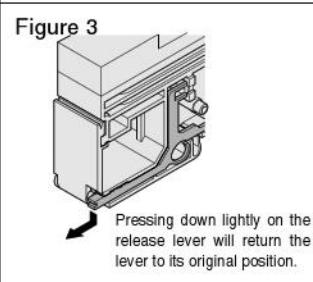
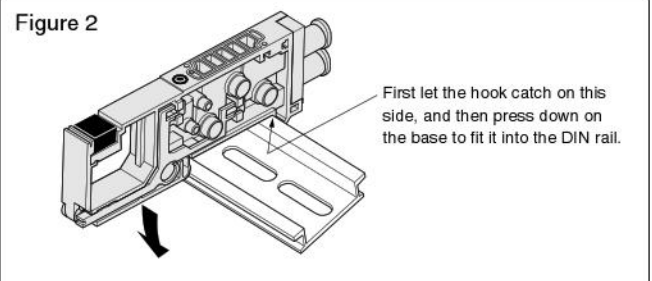

Caution: The new end block for the GF10 series does not include an L-shaped hook. To remove the end block from the DIN rail, loosen the end block fixing screws, and lift it off. (The switch to the new type will commence in October 2000)

SOLENOID VALVES GF SERIES

GF18 Series Disassembly Diagram of Split Manifold Non-Plug-in Type

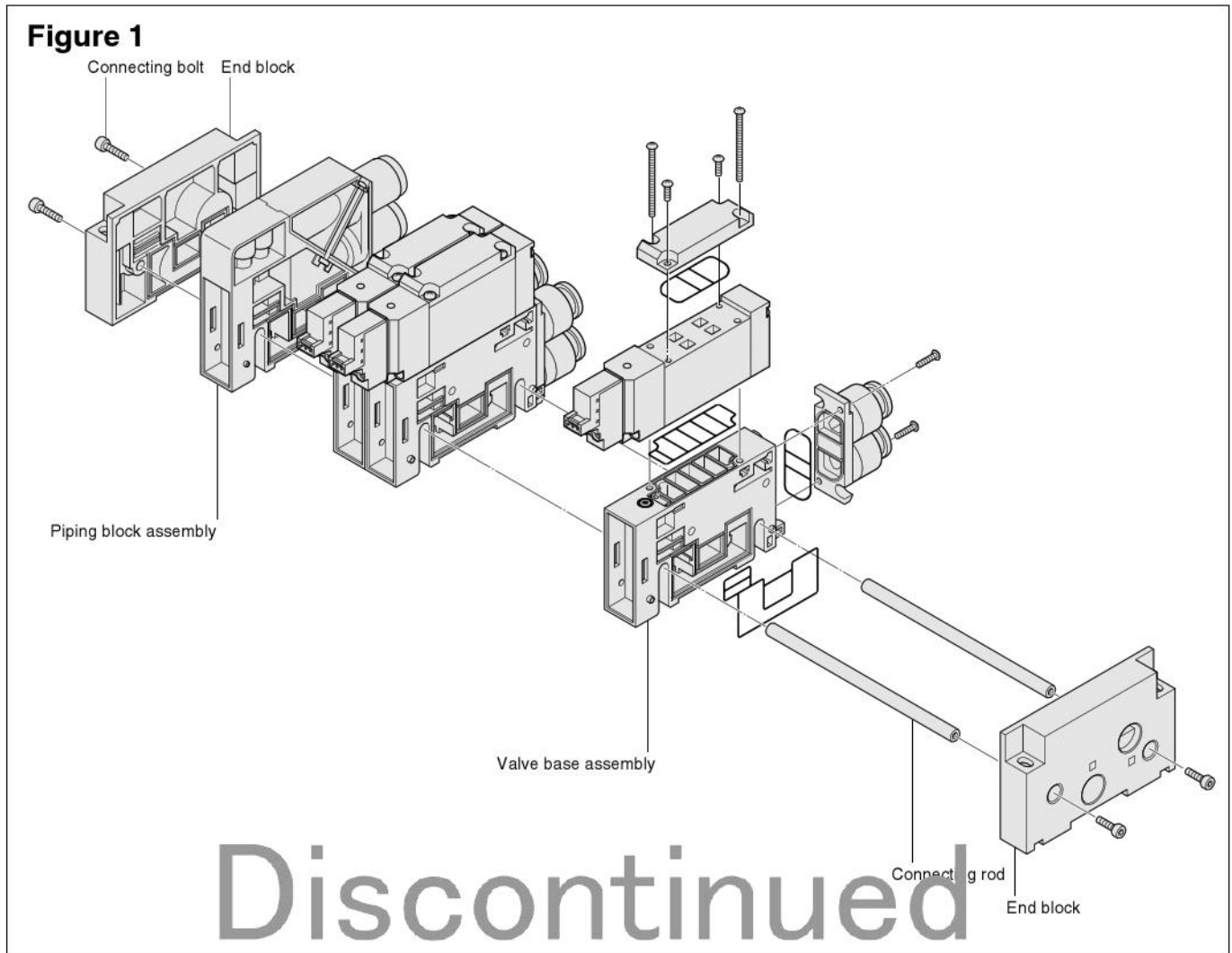

Manifold Unit Adding Procedure (GF18 Series Non-Plug-in Type)

■ Adding valve base unit

Use the valve base assembly and connecting rods to add valve base units.

- ① Remove the connecting bolts on the end block, and separate the end block from the manifold (see Figure 1).
- ② Install the connecting rods to be added, open up spaces where the units are being added, attach gaskets into the valve base assemblies being added, and fit the units on the connecting rods. At this time, securely mount so that no clearance is left between the added valve base assembly and the upper surface of the connecting rods.
- ③ Fit gaskets into the end blocks removed in Step ①, and retighten the connecting bolts. At this time, use a hexagonal bar spanner to hold the connecting bolts on the opposite side in place so as to prevent the bolts from slipping while tightening them into place. Tightening torque: 147N·cm {15kgf·cm}

[Cautions]

- Always cut off the power and air supply before working. In addition, always confirm that air has been completely exhausted from the manifold.
- Be careful not to get caught or lose the gaskets.
- Before supplying air to the manifold, always confirm that the bases are connected, the end block connecting bolts on both sides are securely tightened, etc. Supplying air when either of the end blocks is not securely fixed in place could result in air leaks or in separated manifold bases.
- When there are large number of valves simultaneously supplying air to the secondary side, or when there is a large number of valve units, we recommend to use two sources of air supply and exhaust (on each side).

Note that adding units to the piping block assembly is performed in the same way as adding units to the valve base assembly.

Operating Principle and Symbol

5-port, 2-position

(De-energized)

(De-energized condition after energizing solenoid SB)

Single solenoid
GF10T1-A1-PS

Double solenoid
GF10T2-A1-PS

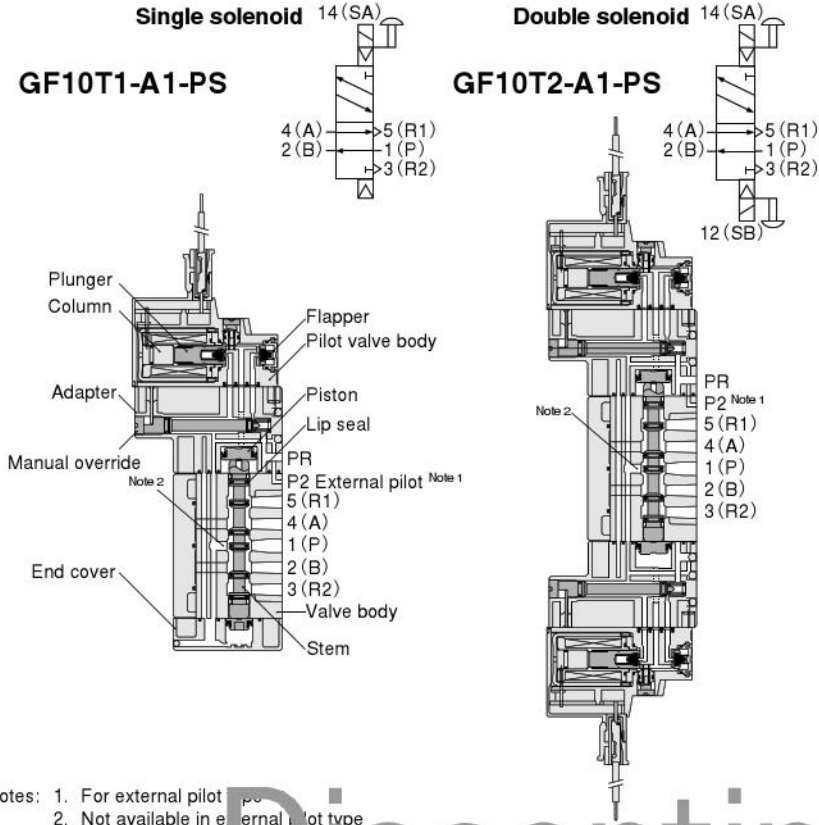

Notes: 1. For external pilot type
2. Not available in external pilot type

Major Parts and Materials

Parts		Materials
Valve	Valve body	Aluminum die-cast
	Pilot valve body	Plastic
	Stem	Aluminum alloy
	Lip seal	Synthetic rubber
	Flapper	Synthetic rubber
	Plunger	Magnetic stainless
	Column	Magnetic stainless
	Piston	Magnetic stainless
	Manual override	Plastic
	Adapter	Plastic
Manifold	End cover	Plastic
	Body	Monoblock type: Aluminum alloy (anodized) Split type: Plastic
	Block off plate	Steel (nickel plated)
	Seal	Synthetic rubber

Discontinued

5-port, 3-position

(Both SA and SB are de-energized)

All port block
GF10T3-A1-PS

ABR connection
GF10T4-A1-PS

PAB connection
GF10T5-A1-PS

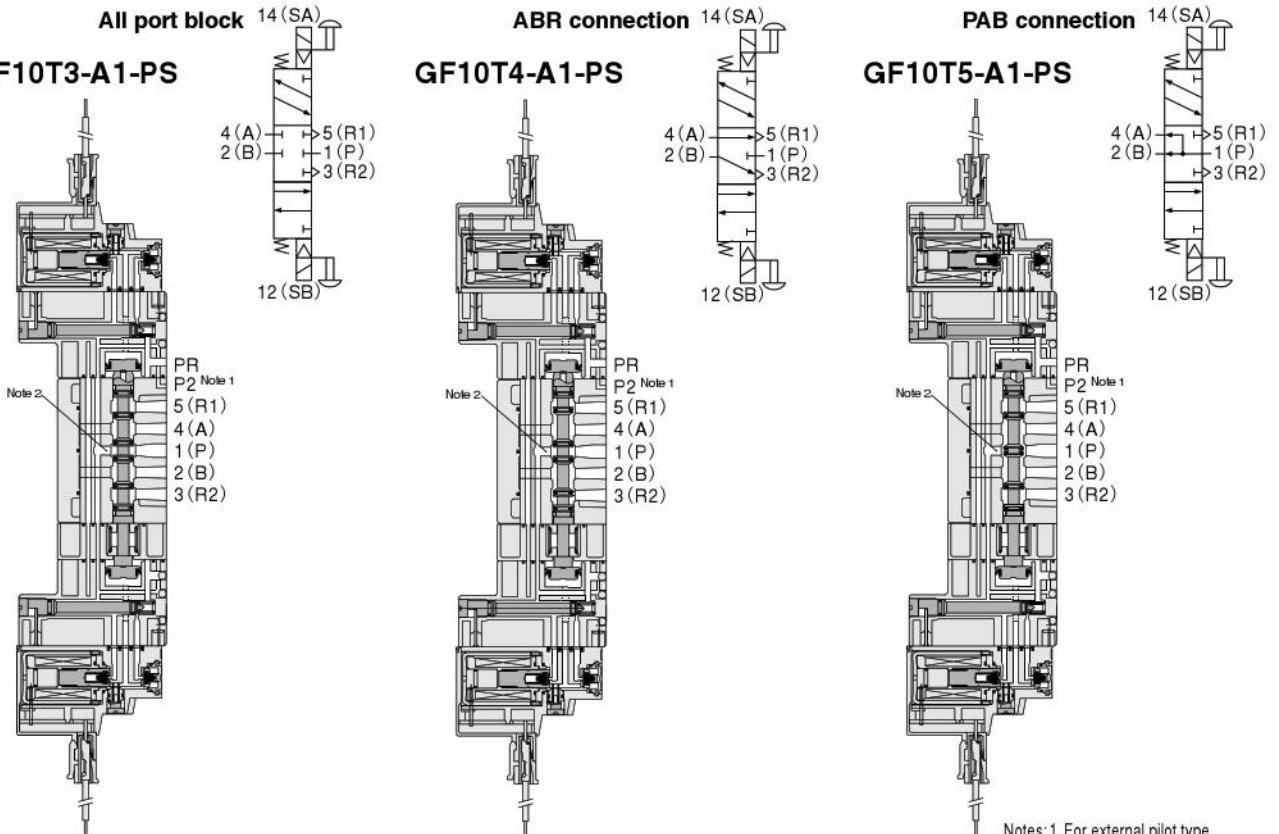

Notes: 1. For external pilot type
2. Not available in external pilot type

GF Series Order Code

The solenoid valves GF series order codes are classified into the following 6 categories.

For details on order codes, see the designated pages.

GF

Koganei solenoid valves **GF**series

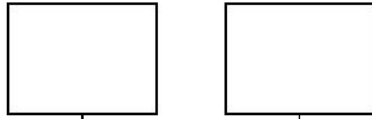

Valve size

- **10**: 10mm width
(Effective area 5mm²)
- **15**: 15mm width
(Effective area 10mm²)
- **18**: 18mm width
(Effective area 18mm²)

T: Single valve unit



p. 448

M **A**: Monoblock manifold
A type (base piping type)

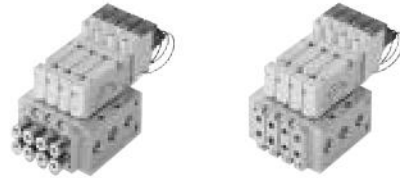

p. 450

M **AC**: Monoblock compact manifold
A type (base piping type)

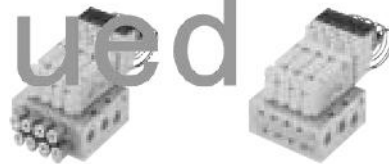

p. 452

M **F**: Monoblock manifold
F type (direct piping type)

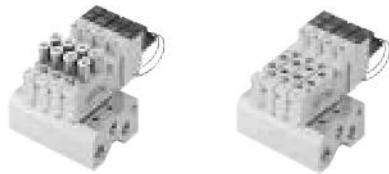

p. 454

M **FC**: Monoblock compact manifold
F type (direct piping type)



p. 456

M **N**: Split manifold non-plug-in type

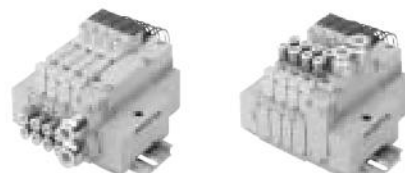

p. 458

Discontinued

Single Valve Unit Order Code



Valve size



Valve specification

2-position
(single solenoid)

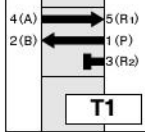

2-position
(double solenoid)

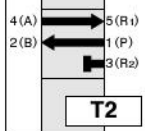

3-position
(all port block)

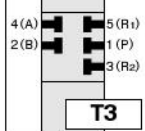

3-position
(ABR connection)

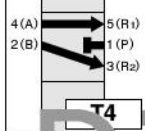

3-position
(PAE connection)

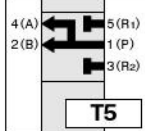

Operation method

Blank
Internal pilot type

G
External pilot type
(for positive pressure)

V
External pilot type
(for vacuum)*
*: This is a vacuum valve.

Manual override

Manual override
(locking type)

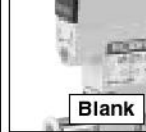

Manual override
(non-locking type)

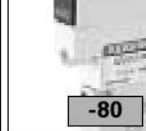

Valve type

Without input/
output block

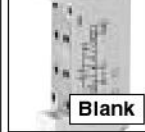

A type
with plate on output section

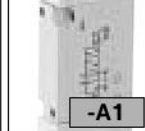

A type with sub-base

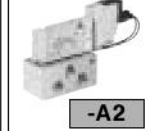

Output port
GF10: Rc1/8
GF15: Rc1/8
GF18: Rc1/4

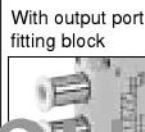

GF10: ϕ 4
GF15: ϕ 6
GF18: ϕ 8

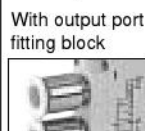

With output port fitting block
GF10: ϕ 6
GF15: ϕ 8
GF18: ϕ 10

With output port
female thread block

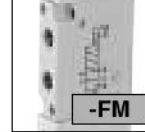

GF10: M5×0.8
GF15: Rc1/8
GF18: Rc1/4

With output port female thread block
With input port female thread block

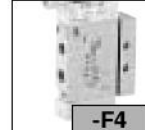

Output port
GF10: M5×0.8
GF15: Rc1/8
GF18: Rc1/4

With output port fitting block
With input port female thread block

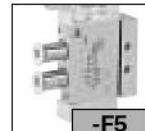

Output port
GF10: ϕ 4
GF15: ϕ 6
GF18: ϕ 8

With output port fitting block
With input port female thread block

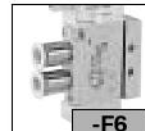

Output port
GF10: ϕ 6
GF15: ϕ 8
GF18: ϕ 10

Wiring

Grommet type
Lead wire length 300mm

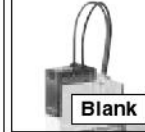

S type plug connector
Lead wire length 300mm

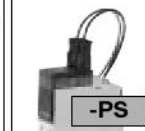

L type plug connector
Lead wire length 300mm



S type plug connector
Lead wire length 3000mm

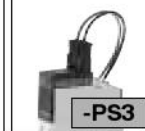

L type plug connector
Lead wire length 3000mm



Valve size

Valve specification

Operation method

Manual override

Valve type

Wiring

Voltage

GF10
GF15
GF18

T1
T2
T3
T4^{Note 3}
T5^{Note 3}

Blank
G
V

Blank
-80

Blank^{Note 1}
-A1^{Note 1}
-A2^{Note 1}
-FJ5^{Note 1}
-FJ6^{Note 1}
-FM^{Note 1}
-F4^{Note 2}
-F5^{Note 2}
-F6^{Note 2}

Blank
-PS
-PL
-PS3
-PL3

DC24V
DC12V
AC100V
AC200V

^{Note 4}

Notes: 1. Two mounting screws for the manifold are included.

2. The units with input port female thread block can respond only to the internal pilot type valve in the operation method.

3. Not available in the vacuum valve.

4. For AC110V~120V or AC 220V~240V specifications, consult us.

Additional Parts Order Code for Single Valve Unit

● For internal pilot

F Z -

Valve size

10: 10mm width
15: 15mm width
18: 18mm width

Parts content

21 : Mounting bracket (mounting bracket, 2 mounting screws) ^{Note 1}
25 : Sub-base (sub-base body, gasket, exhaust valve) ^{Note 2}
P : Plate (plate, gasket, 2 mounting screws)
M : Female thread block (female thread block, gasket, 2 mounting screws)
MP : P port female thread block (P port female thread block, gasket) ^{Note 2}
GS1 : Gasket (gasket, exhaust valve) ^{Note 3}

Notes: 1. Cannot be mounted on any but valve specification T1.
2. Valve mounting screws are not included.
3. Note that this is different from gasket **GS2** used for the split manifold.

● For external pilot

F Z -

Valve size

10: 10mm width
15: 15mm width
18: 18mm width

Parts content

P : Plate (plate, gasket, 2 mounting screws)
M : Female thread block (female thread block, gasket, 2 mounting screws)
GS1 : Gasket (gasket, exhaust valve) ^{Note}

Note: Note that this is different from gasket **GS2** used for the split manifold.

Sub-base for external pilot

F ZG - 25

Valve size

10: 10mm width
15: 15mm width
18: 18mm width

Discontinued

● Fitting block (for both internal pilot and external pilot)

GF Z -

Valve size

10: 10mm width
15: 15mm width
18: 18mm width

Parts content

J5: Fitting block GF10: ϕ 4, GF15: ϕ 6, GF18: ϕ 8 (fitting block, gasket, two mounting screws)
J6: Fitting block GF10: ϕ 6, GF15: ϕ 8, GF18: ϕ 10 (fitting block, gasket, two mounting screws)

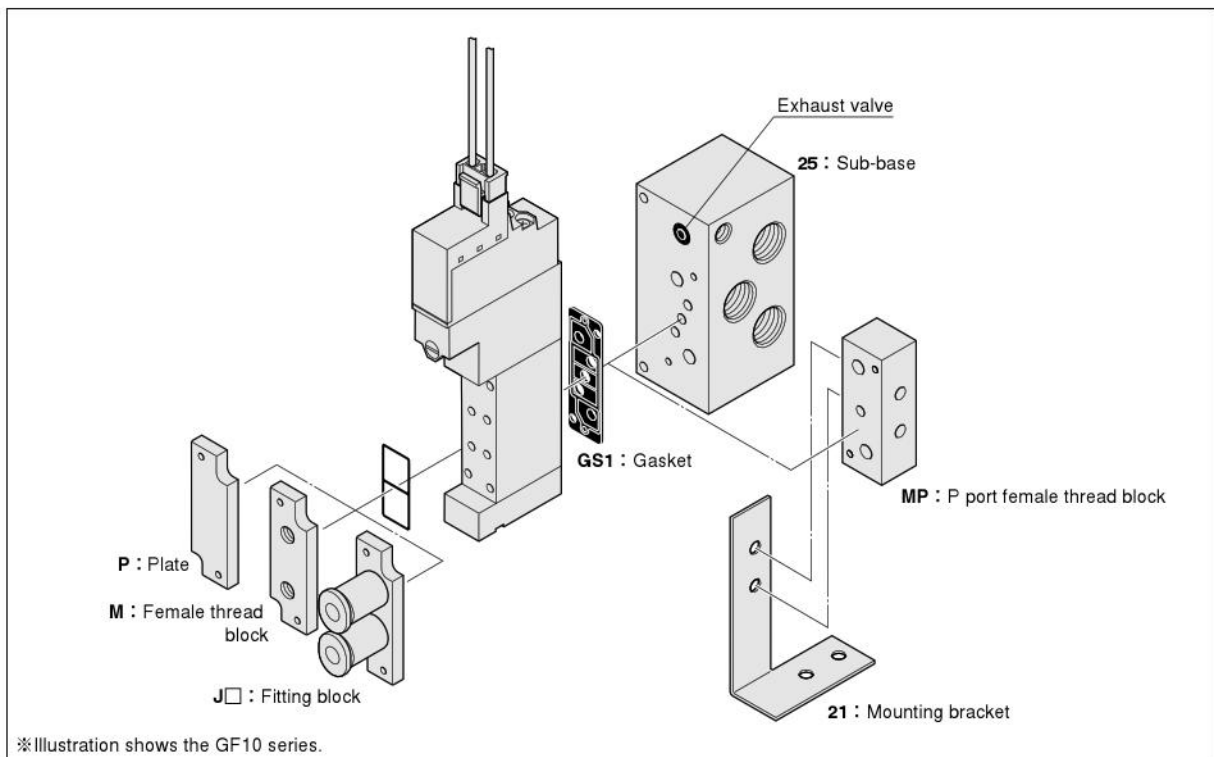

Monoblock Manifold A Type Additional Parts Order Code

Gasket (gasket, exhaust valve)

F Z - GS1

Valve size
 10: 10mm width
 15: 15mm width
 18: 18mm width

Individual air supply and exhaust spacer (spacer, gasket, exhaust valve, 2 mounting screws)

F Z -

Valve size
 10: 10mm width
 15: 15mm width
 18: 18mm width

Specification
 NPM : Individual air supply spacer (with M5 female thread for GF10)
 NP6 : Individual air supply spacer (with ϕ 6 fitting for GF15)
 NP8 : Individual air supply spacer (with ϕ 8 fitting for GF15 and GF18)
 NP0 : Individual air supply spacer (with ϕ 10 fitting for GF18)
 NRM : Individual exhaust spacer (with M5 female thread for GF10)
 NR6 : Individual exhaust spacer (with ϕ 6 fitting for GF15)
 NR8 : Individual exhaust spacer (with ϕ 8 fitting for GF15 and GF18)
 NR0 : Individual exhaust spacer (with ϕ 10 fitting for GF18)

※ For details, see p.442.

Block-off plate (block-off plate, 2 mounting screws)

GF BP

Valve size
 10: 10mm width
 15: 15mm width
 18: 18mm width

Lead wire for common wiring

G010-COM

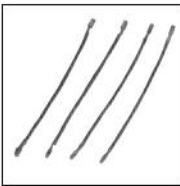

● For -PS, -PL, -PS3, -PL3
 (see p.442 piece)

Discontinued

Muffler

KM - J

Fitting size
 6 : Outer diameter ϕ 6 (for individual exhaust spacer)
 8 : Outer diameter ϕ 8 (for individual exhaust spacer)
 10: Outer diameter ϕ 10 (for individual exhaust spacer)
 (Sales unit: set of 10 pieces)

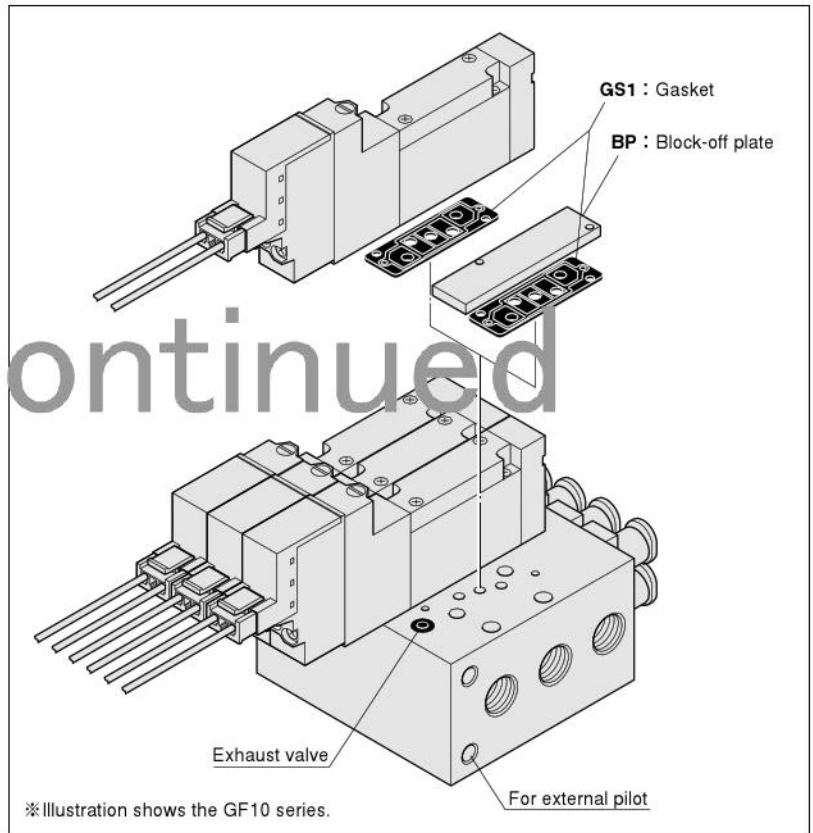

SOLENOID VALVES GF SERIES

Manifold Order Code Example (6 units of GF10 series)

GF10M6AJ

stn.1~2 GF10T1-A1-PS-J5 DC24V
 stn.3~5 GF10T2-A1-PS-J6 DC24V
 stn.6 GF10BP-J5

Note: This order code example has no relationship to the above illustration.

Order Code Precautions

- Manifold output specification
 Select with either a fitting block or a female thread block.
 For repairs and replacements, purchase from the additional parts for single valve unit from GFZ-J (fitting block) or FZ-M (female thread block) on p.449.
- Orders for valves only
 Place order by "Single Valve Unit Order Code" on p.448.
 Note, however, that valve type are limited to -A1 (with plate) only. The -J5 and -J6 codes are for ordering with manifolds.

Additional Parts Order Code for Monoblock Compact Manifold A Type

Gasket (gasket, exhaust valve)

F Z - GS1

Valve size
10: 10mm width
15: 15mm width

Individual air supply and exhaust spacer (spacer, gasket, exhaust valve, 2 mounting screws)

F Z -

Valve size
10: 10mm width
15: 15mm width

Specification

NPM : Individual air supply spacer (with M5 female thread for GF10)
NP6 : Individual air supply spacer (with ϕ 6 fitting for GF15)
NP8 : Individual air supply spacer (with ϕ 8 fitting for GF15)
NRM : Individual exhaust spacer (with M5 female thread for GF10)
NR6 : Individual exhaust spacer (with ϕ 6 fitting for GF15)
NR8 : Individual exhaust spacer (with ϕ 8 fitting for GF15)

Block-off plate (block-off plate, 2 mounting screws)

GF BP

Valve size
10: 10mm width
15: 15mm width

Note : Individual air supply and exhaust spacers cannot be mounted on any but valve specification T1.

※ For details, see p.442.

Lead wire for common wiring

G010-COM

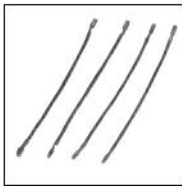

● For -PS, -PL, -PS3, -PL3
(set of 10 pieces)

Discontinued

Muffler

KM - J

Fitting size
6 : Outer diameter ϕ 6 (for individual exhaust spacer)
8 : Outer diameter ϕ 8 (for individual exhaust spacer)
(Sales unit: set of 10 pieces)

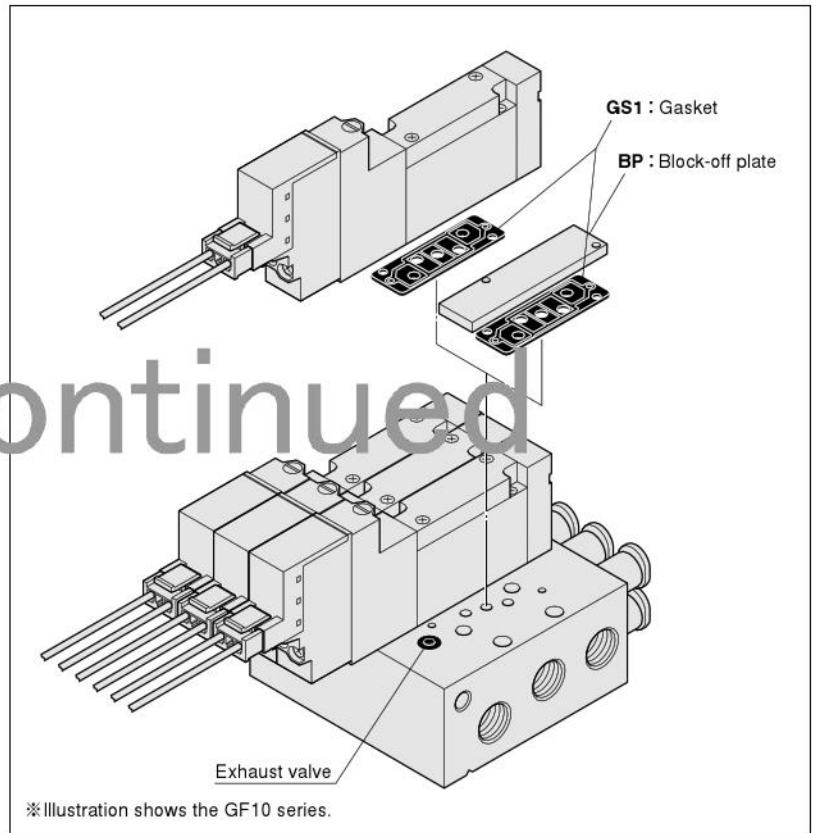

SOLENOID VALVES GF SERIES

Manifold Order Code Example (6 units of GF10 series)

GF10M6ACJ

stn.1~2 GF10T1-A1-PS-J5 DC24V
 stn.3~5 GF10T2-A1-PS-J6 DC24V
 stn.6 GF10BP-J5

Note: This order code example has no relationship to the above illustration.

Order Code Precaution

- Manifold output specification
Select with either fitting specification or female thread specification.
- Orders for valves only
Place order by "Single Valve Unit Order Code" on p.448.
Note, however, that valve type are limited to -A1 (with plate) only. The -J5 and -J6 are for ordering with manifolds.

Monoblock Manifold F type (Direct Piping Type) Order Code

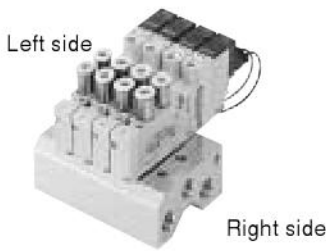

Valve size

10mm width
Effective area 5mm²
GF10

15mm width
Effective area 10mm²
GF15

18mm width
Effective area 18mm²
GF18

Manual override

Manual override (locking type)
Blank

Manual override (non-locking type)
-80

Valve type

With fitting block
-FJ5

Output port fitting
GF10: φ 4
GF15: φ 6
GF18: φ 8

With fitting block
-FJ6

Output port fitting
GF10: φ 6
GF15: φ 8
GF18: φ 10

With female thread block
-FM

Output port female thread
GF10: M5×0.8
GF15: Rc1/8
GF18: Rc1/4

Wiring

Grommet type
Lead wire length 300mm
Blank

S type plug connector
Lead wire length 300mm
-PS

S type plug connector
Lead wire length 300mm
-PS3

L type plug connector
Lead wire length 300mm
-PL

L type plug connector
Lead wire length 300mm
-PL3

Individual air supply and exhaust spacer^{Note 3}

Blank : Without spacer
-NPM : Individual air supply spacer (with M5 female thread for GF10)
-NP6 : Individual air supply spacer (with φ 6 fitting for GF15)
-NP8 : Individual air supply spacer (with φ 8 fitting for GF15 and GF18)
-NP0 : Individual air supply spacer (with φ 10 fitting for GF18)
-NRM : Individual exhaust spacer (with M5 female thread for GF10)
-NR6 : Individual exhaust spacer (with φ 6 fitting for GF15)
-NR8 : Individual exhaust spacer (with φ 8 fitting for GF15 and GF18)
-NR0 : Individual exhaust spacer (with φ 10 fitting for GF18)
 ※ For details, see p. 442.

Discontinued

Note: Valves of different sizes can not be combined together for mounting.

Valve size	Number of units	Station	Valve size	Valve specification	Manual override	Valve type	Wiring	Individual air supply and exhaust spacer	Voltage
Manifold model		Mounting valve type							
GF10M	2	stn. <input type="checkbox"/>	GF10	T1 : 2-position single solenoid	Blank	-FJ5	Blank	Blank	DC24V
GF15M	.	.	GF15	T2 : 2-position double solenoid	-80	-FJ6	-PS	-NPM	DC12V
GF18M	.	.	GF18	T3 : 3-position all port block		-FM	-PL	-NP6	AC100V
	20	stn. <input type="checkbox"/>		T4 : 3-position ABR connection			-PS3	-NP0	AC200V
		Note 1		T5 : 3-position PAB connection			-PL3	-NRM	Note 4
								-NR6	
								-NR8	
								-NR0	
BP (for block-off plate)									

Notes: 1. Valve mounting position from the left, with the solenoid on top and the A and B port in the front.
 2. The external pilot type valve cannot be mounted on the F type manifold.
 3. Individual air supply and exhaust spacers cannot be mounted on any but valve specification T1.
 4. For AC110V~120V or AC 220V~240V specifications, consult us.

Additional Parts Order Code for Monoblock Manifold F Type

Gasket (gasket, exhaust valve)

F Z - GS1

Valve size

- 10: 10mm width
- 15: 15mm width
- 18: 18mm width

Individual air supply and exhaust spacer (spacer, gasket, exhaust valve, 2 mounting screws)

F Z -

Valve size

- 10: 10mm width
- 15: 15mm width
- 18: 18mm width

Specification

- NPM** : Individual air supply spacer (with M5 female thread for GF10)
- NP6** : Individual air supply spacer (with ϕ 6 fitting for GF15)
- NP8** : Individual air supply spacer (with ϕ 8 fitting for GF15 and GF18)
- NP0** : Individual air supply spacer (with ϕ 10 fitting for GF18)
- NRM** : Individual exhaust spacer (with M5 female thread for GF10)
- NR6** : Individual exhaust spacer (with ϕ 6 fitting for GF15)
- NR8** : Individual exhaust spacer (with ϕ 8 fitting for GF15 and GF18)
- NR0** : Individual exhaust spacer (with ϕ 10 fitting for GF18)

Block-off plate (block-off plate, 2 mounting screws)

GF BP

Valve size

- 10: 10mm width
- 15: 15mm width
- 18: 18mm width

※ For details, see p.442.

Lead wire for common wiring

G010-COM

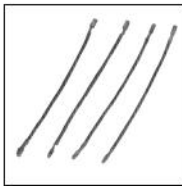

- For -PS, -PL, -PS3, -PL3 (set of 10 pieces)

Muffler

KM - J

Fitting size

- 6** : Outer diameter ϕ 6 (for individual exhaust spacer)
- 8** : Outer diameter ϕ 8 (for individual exhaust spacer)
- 10** : Outer diameter ϕ 10 (for individual exhaust spacer)

(Sales unit: set of 10 pieces)

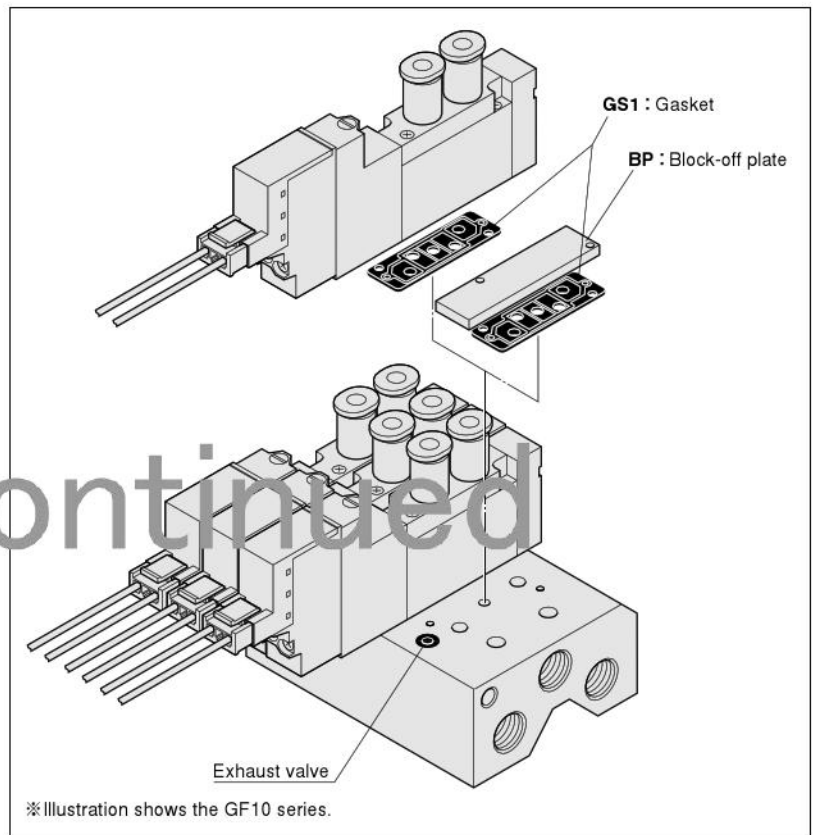

※ Illustration shows the GF10 series.

Discontinued

SOLENOID VALVES GF SERIES

Manifold Order Code Example (4 units of GF10 series)

GF10M4F

- stn.1~2 GF10T1-FJ5-PS DC24V
- stn.3 GF10T2-FJ6-PS DC24V
- stn.4 GF10BP

Note: This order code example has no relationship to the above illustration.

Order Code Precautions

- Orders for valves only
Place order by "Single Valve Unit Order Code" on p.448.
Note, however, that valve type selection is limited to -FJ5, -FJ6, -FM.

Monoblock Compact Manifold F type (Direct Piping Type) Order Code

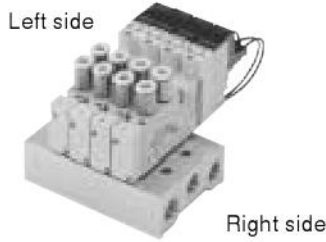

Valve size

10mm width

Effective area 5mm²



15mm width

Effective area 10mm²



Manual override

Manual override (locking type)

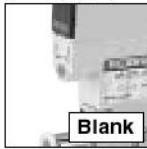

Manual override (non-locking type)

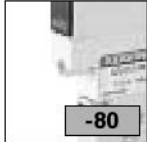

Valve type

With fitting block



Output port fitting
GF10: ϕ 4
GF15: ϕ 6

With fitting block

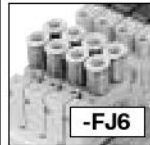

Output port fitting
GF10: ϕ 6
GF15: ϕ 8

With female thread block

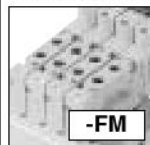

Output port female thread
GF10: M5 \times 0.8
GF15: Rc1/8

Wiring

Grommet type
Lead wire length 300mm

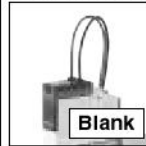

S type plug connector
Lead wire length 300mm

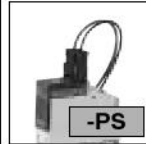

S type plug connector
Lead wire length 300mm

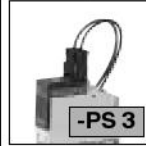

L type plug connector
Lead wire length 300mm

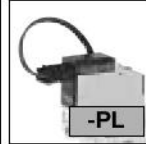

L type plug connector
Lead wire length 300mm

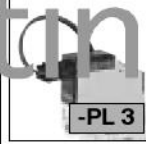

Individual air supply and exhaust spacer^{Note 3}

- Blank** : Without spacer
 - NPM** : Individual air supply spacer (with M5 female thread for GF10)
 - NP6** : Individual air supply spacer (with ϕ 6 fitting for GF15)
 - NP8** : Individual air supply spacer (with ϕ 8 fitting for GF15)
 - NRM** : Individual exhaust spacer (with M5 female thread for GF10)
 - NR6** : Individual exhaust spacer (with ϕ 6 fitting for GF15)
 - NR8** : Individual exhaust spacer (with ϕ 8 fitting for GF15)
- ※ For details, see p. 442.

Discontinued

Note: Valves of different sizes can not be combined together for mounting.

Valve size	Number of units	Station	Valve size	Valve specification	Manual override	Valve type	Wiring	Individual air supply and exhaust spacer	Voltage	
Manifold model		Mounting valve type								
GF10M GF15M	2 . . . 20	FC ^{Note 2}	stn. <input type="checkbox"/> . . . stn. <input type="checkbox"/> Note 1	GF10 GF15	T1 : 2-position single solenoid T2 : 2-position double solenoid T3 : 3-position all port block T4 : 3-position ABR connection T5 : 3-position PAB connection	Blank -80	-FJ5 -FJ6 -FM	Blank -PS -PL -PS3 -PL3	^{Note 3} Blank -NPM -NP6 -NP8 -NRM -NR6 -NR8	DC24V DC12V AC100V AC200V Note 4
BP (for block-off plate)										

Notes: 1. Valve mounting position from the left, with the solenoid on top and the A and B port in the front.
 2. The external pilot type valve cannot be mounted on the F type manifold.
 3. Individual air supply and exhaust spacers cannot be mounted on any but valve specification T1.
 4. For AC110V~120V or AC 220V~240V specifications, consult us.

Monoblock Compact Manifold F type Additional Parts Order Code

Gasket (gasket, exhaust valve)

F **Z - GS1**

Valve size
 10: 10mm width
 15: 15mm width

Individual air supply and exhaust spacer (spacer, gasket, exhaust valve, 2 mounting screws)

F **Z -**

Valve size
 10: 10mm width
 15: 15mm width

Specification
NPM : Individual air supply spacer (with M5 female thread for GF10)
NP6 : Individual air supply spacer (with ϕ 6 fitting for GF15)
NP8 : Individual air supply spacer (with ϕ 8 fitting for GF15)
NRM : Individual exhaust spacer (with M5 female thread for GF10)
NR6 : Individual exhaust spacer (with ϕ 6 fitting for GF15)
NR8 : Individual exhaust spacer (with ϕ 8 fitting for GF15)

Block-off plate (block-off plate, 2 mounting screws)

GF **BP**

Valve size
 10: 10mm width
 15: 15mm width

Note : Individual air supply and exhaust spacers cannot be mounted on any but valve specification **T1**.
 ※ For details, see p.442.

Lead wire for common wiring

G010-COM

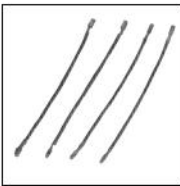

● For -PS, -PL, -PS3, -PL3 (set of 10 pieces)

Discontinued

Muffler

KM - J

Fitting size
6 : Outer diameter ϕ 6 (for individual exhaust spacer)
8 : Outer diameter ϕ 8 (for individual exhaust spacer)
 (Sales unit: set of 10 pieces)

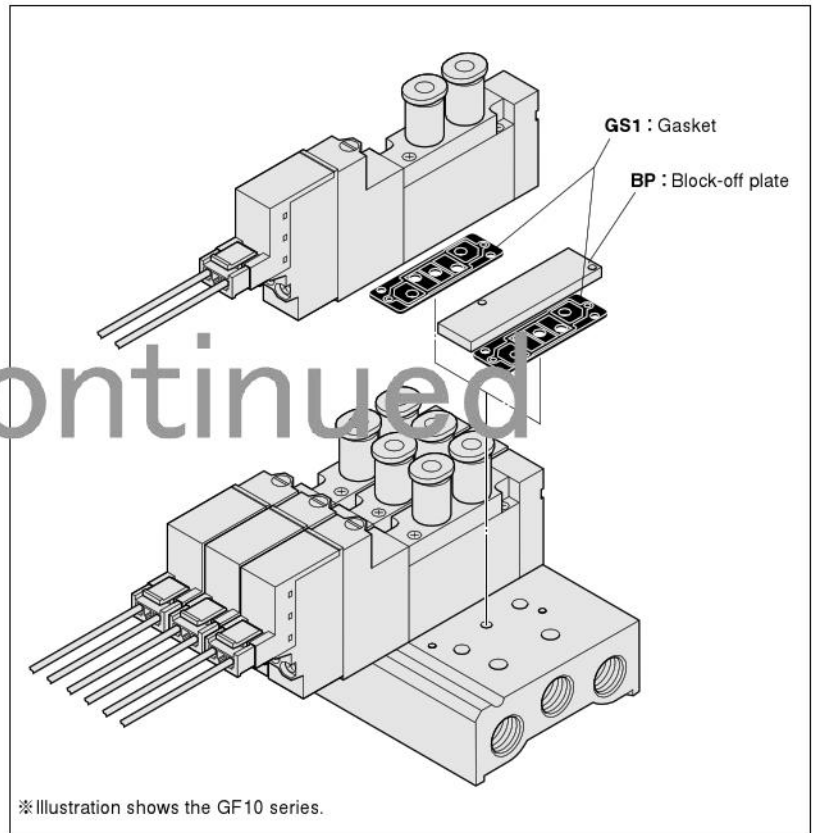

SOLENOID VALVES GF SERIES

Manifold Order Code Example (4 units of GF10 series)

GF10M4FC

stn.1~2 **GF10T1-FJ5-PS DC24V**
 stn.3 **GF10T2-FJ6-PS DC24V**
 stn.4 **GF10BP**

Note: This order code example has no relationship to the above illustration.

Order Code Precautions

- Orders for valves only
 Place order by "Single Valve Unit Order Code" on p.448
 Note, however, that valve type selection is limited to **-FJ5, -FJ6, -FM**.

Split Manifold Non-Plug-in Type Order Code

Manifold output specification

With fitting block (base piping type)

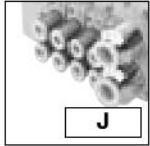

J

Output port fitting

With female thread block (base piping type)

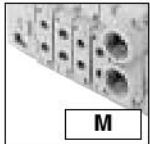

M

Output port female thread
GF10: M5×0.8
GF15: Rc1/8
GF18: Rc1/4

With plate (direct piping type)

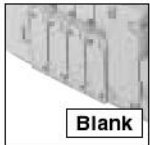

Blank

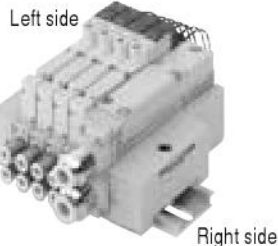

Piping block specification

-JR: With fitting on right side
-JL: With fitting on left side
-JD: With fittings on both sides

P, R port fitting

GF10: φ 8
GF15: φ 10
GF18: φ 12

-MR: With female thread on right side
-ML: With female thread on left side
-MD: With female thread on both sides

P, R port female thread

GF10: Rc1/4
GF15: Rc1/4
GF18: Rc3/8

Manual override

Manual override (locking type)



Blank

Manual override (non-locking type)

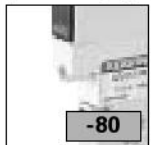

-80

Operation method

Blank

Internal pilot type^{Note 4}

G

External pilot type^{Note 5}
 (for positive pressure)
 ※ No vacuum valve can be mounted.

Valve type

With plate (base piping type)

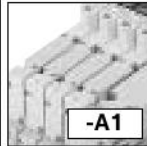

-A1

With fitting block (direct piping type)

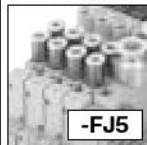

-FJ5

Output port fitting

GF10: φ 4
GF15: φ 6
GF18: φ 8

With fitting block (direct piping type)



-FJ6

Output port fitting

GF10: φ 4
GF15: φ 6
GF18: φ 8

With female thread block (direct piping type)

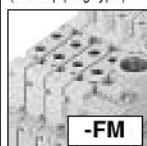

-FM

Output port female thread

GF10: M5×0.8
GF15: Rc1/8
GF18: Rc1/4

Wiring

Grommet type
 Lead wire length 300mm

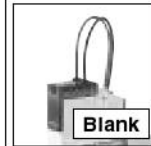

Blank

S type plug connector
 Lead wire length 300mm

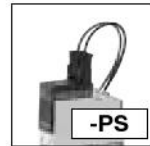

-PS

S type plug connector
 Lead wire length 3000mm

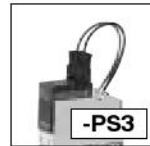

-PS3

L type plug connector
 Lead wire length 300mm

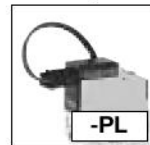

-PL

L type plug connector
 Lead wire length 3000mm

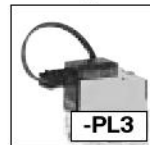

-PL3

Manifold fitting specification

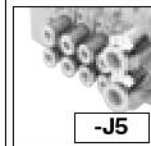

-J5

Manifold side output port fitting

GF10: φ 4
GF15: φ 6
GF18: φ 8

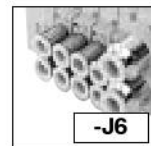

-J6

Manifold side output port fitting

GF10: φ 6
GF15: φ 8
GF18: φ 10

Individual air supply and exhaust spacer^{Note 7}

Blank: Without spacer

-NPM: Individual air supply spacer (with M5 female thread for GF10)
-NP6: Individual air supply spacer (with φ 6 fitting for GF15)
-NP8: Individual air supply spacer (with φ 8 fitting for GF15 and GF18)
-NP0: Individual air supply spacer (with φ 10 fitting for GF18)
-NRM: Individual exhaust spacer (with M5 female thread for GF10)
-NR6: Individual exhaust spacer (with φ 6 fitting for GF15)
-NR8: Individual exhaust spacer (with φ 8 fitting for GF15 and GF18)
-NR0: Individual exhaust spacer (with φ 10 fitting for GF18)
 ※ For details, see p. 442.

Split

Blank: Without split

-SP: For P port^{Note 3}
-SR: For R port^{Note 3}
-SA: For both P and R ports^{Note 3}

Valve size

GF10M

10mm width
 Effective area 5mm²

GF15M

15mm width
 Effective area 10mm²

GF18M

18mm width
 Effective area 18mm²

Pilot specification

Blank

Internal pilot manifold

G

External pilot manifold

Valve specification

T1: 2-position, single solenoid
T2: 2-position, double solenoid
T3: 3-position, all port block
T4: 3-position, ABR connection
T5: 3-position, PAB connection

Note: Valves of different sizes cannot be combined together for mounting.

Valve size	Number of units	Manifold output specification	Pilot specification	Piping block specification	Station	Valve size	Valve specification	Operation method	Manual override	Valve type	Wiring	Manifold fitting specification	Individual air supply and exhaust spacer	Split	Voltage
------------	-----------------	-------------------------------	---------------------	----------------------------	---------	------------	---------------------	------------------	-----------------	------------	--------	--------------------------------	--	-------	---------

Base piping type	Manifold model	Number of units	Manifold output specification	Pilot specification	Piping block specification	Station	Valve size	Valve specification	Operation method	Manual override	Valve type	Wiring	Manifold fitting specification	Individual air supply and exhaust spacer	Split	Voltage	
																	Mounting valve type
Base piping type	J	2	Blank	G	-JR -MR -JL -ML -JD -MD	stn. □ : stn. □ Note 1	GF10 GF15 GF18	T1 T4 T2 T5 T3	Blank ^{Note 4} G ^{Note 5}	Blank	-A1 Note 2	Blank -PS -PL -PS3 -PL3	-J5 -J6 Note 6	Blank -NPM -NP6 -NP8 -NP0 -NRM -NR6 -NR8 -NR0	Blank -SP ^{Note 3} -SR ^{Note 3} -SA ^{Note 3}	DC24V DC12V AC100V AC200V Note 8	
																	BPN(block-off plate)
																	M
Base piping type	M	20	Blank	G	-JR -MR -JL -ML -JD -MD	stn. □ : stn. □ Note 1	GF10 GF15 GF18	T1 T4 T2 T5 T3	Blank ^{Note 4} G ^{Note 5}	Blank	-A1 Note 2	Blank -PS -PL -PS3 -PL3	Blank -NPM -NP6 -NP8 -NP0 -NRM -NR6 -NR8 -NR0	Blank -SP ^{Note 3} -SR ^{Note 3} -SA ^{Note 3}	DC24V DC12V AC100V AC200V Note 8		
																BPN(block-off plate)	
																Blank	
Direct piping type	Blank	Blank	G	-JR -MR -JL -ML -JD -MD	stn. □ : stn. □ Note 1	GF10 GF15 GF18	T1 T4 T2 T5 T3	Blank ^{Note 4} G ^{Note 5}	Blank	-FJ5 -FJ6 -FM	Blank -PS -PL -PS3 -PL3	Blank -NPM -NP6 -NP8 -NP0 -NRM -NR6 -NR8 -NR0	Blank -SP ^{Note 3} -SR ^{Note 3} -SA ^{Note 3}	DC24V DC12V AC100V AC200V Note 8			
															BPN(block-off plate)		

- Notes: 1. Valve mounting position from the left, with the solenoid on top and the A and B port in the front.
 2. When selecting **J** or **M** (base piping type) for the manifold output specification, always enter **-A1** (with plate) for the valve type.
 3. Split can be mounted as long as piping blocks are attached to both sides. In addition, the number of splits that can be mounted on one manifold is limited to one location (one station).
 Splits are installed at time of delivery in the place between the designated station and the station to its left (the side with the smaller station number).
 4. Cannot be mounted on the external pilot manifold.
 5. Cannot be mounted on the internal pilot manifold.
 6. To select the fitting on the manifold, always enter **-J5** or **-J6** after the valve or block-off plate code.
 7. Individual air supply and exhaust spacers cannot be mounted on any but valve specification **T1**.
 8. For AC110V~120V or AC 220V~240V specifications, consult us.

Additional Parts Order Code for Split Manifold Non-Plug-in Type

Part for manifold

F Z -

Valve size

- 10: 10mm width
- 15: 15mm width
- 18: 18mm width

Parts content

- GS2 :Gasket (gasket, exhaust valve)
- SP :Split (for P port)
- SR :Split (for R port)
- SA :Split (for both P and R ports)

Individual air supply and exhaust spacer (spacer, gasket, exhaust valve, 2 mounting screws)

F Z -

Valve size

- 10: 10mm width
- 15: 15mm width
- 18: 18mm width

Specification

- NPM : Individual air supply spacer (with M5 female thread for GF10)
- NP6 : Individual air supply spacer (with ϕ 6 fitting for GF15)
- NP8 : Individual air supply spacer (with ϕ 8 fitting for GF15 and GF18)
- NP0 : Individual air supply spacer (with ϕ 10 fitting for GF18)
- NRM : Individual exhaust spacer (with M5 female thread for GF10)
- NR6 : Individual exhaust spacer (with ϕ 6 fitting for GF15)
- NR8 : Individual exhaust spacer (with ϕ 8 fitting for GF15 and GF18)
- NRO : Individual exhaust spacer (with ϕ 10 fitting for GF18)

Block-off plate (block-off plate, 2 mounting screws)

GF BP N

Valve size

- 10: 10mm width
- 15: 15mm width
- 18: 18mm width

For non-plug-in

※ For details, see p. 442.

Valve base assembly (valve base, gasket, plug ※1)

GF Z -

Valve size

- 10: 10mm width
- 15: 15mm width
- 18: 18mm width

Piping specification

- VJ5 :Valve base fitting (GF10: ϕ 4, GF15: ϕ 6, GF18: ϕ 8)
- VJ6 :Valve base fitting (GF10: ϕ 6, GF15: ϕ 8, GF18: ϕ 10)
- VM :Valve base female thread
- VP :Valve base plate

Pilot specification

- Blank : Internal pilot※2
- G : External pilot (GF10 and GF15 only)

※ 1: No plug included for GF18.

※ 2: For GF18 covers both internal pilot and external pilot.

End block (a set of left and right)

F Z - E

Valve size

- 10: 10mm width
- 15: 15mm width
- 18: 18mm width

Pilot specification

- Blank : Internal pilot※
- G : External pilot (GF10 and GF15 only)

※ : End block for the GF18 is for both internal pilot and external pilot.

Piping block assembly

GF Z -

Valve size

- 10: 10mm width
- 15: 15mm width
- 18: 18mm width

Piping specification

- PJ : Piping block fitting
- PM : Piping block female thread

Pilot specification

- Blank : Internal pilot
- G : External pilot

Muffler

KM - J

Fitting size

- 6 : Outer diameter ϕ 6 (for individual exhaust spacer)
 - 8 : Outer diameter ϕ 8 (for GF10 or individual exhaust spacer)
 - 10 : Outer diameter ϕ 10 (for GF15 or individual exhaust spacer)
 - 12 : Outer diameter ϕ 12 (for GF18)
- (Sales unit: set of 10 pieces)

Lead wire for common wiring

G010-COM

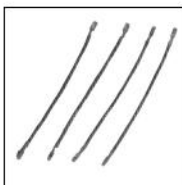

- For -PS, -PL, -PS3, -PL3 (set of 10 pieces)

Discontinued

Connecting rod (GF18 series only)

F18Z - -

Additional unit number

01~20 (RH is 01~04)

※ For reduction of unit, consult us.

Specification

- RV: For valve base
- RH: For piping base

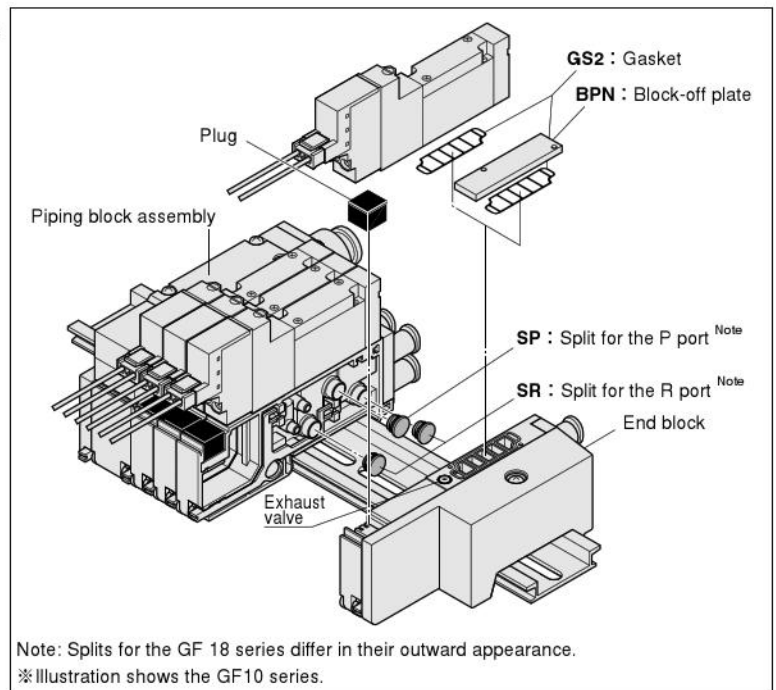

SOLENOID VALVES GF SERIES

Manifold Order Code Example

(4 units of GF10 series)

GF10M4NJ-JR

- stn.1 ~ 2 GF10T1-A1-PS-J5 DC24V
- stn.3 GF10T2-A1-PS-J6 DC24V
- stn.4 GF10BPN-J5

Note: This order code example has no relationship to the above illustration.

Order Code Precautions

- Orders for valves only
Place order by "Single Valve Unit Order Code" on p.448.
Note, however, that **Blank, A2, F4, F5, F6** cannot be selected as the valve type.

SOLENOID VALVES GF10 SERIES

INDEX

Specifications	462
Dimensions of Single Valve Unit	465
Dimensions of Monoblock	
Manifold	469
Dimensions of Monoblock	
Compact Manifold	470
Dimensions of Split Non-Plug-in Type	471



Discontinued

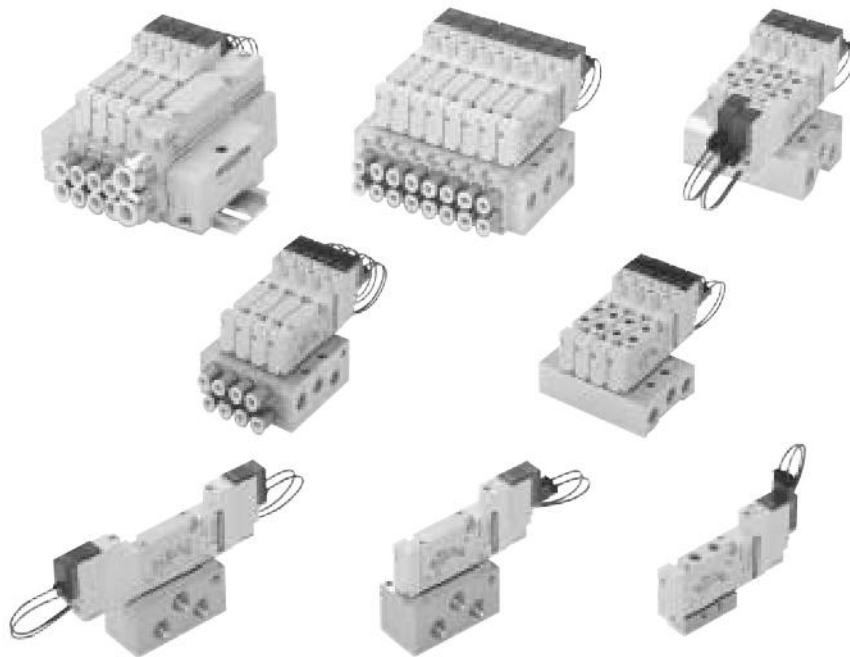

GF10 SERIES SPECIFICATIONS

Specifications

Basic Models and Valve Functions

Item	Basic model	GF10T1 GF10T2	GF10T3 GF10T4 GF10T5
	Number of positions	2 positions	
Number of ports	5		
Valve function	Single solenoid or double solenoid		All port block, ABR connection or PAB connection

Remarks: For optional specifications and order code, see p.448~459.

Specifications

Item	Basic model	GF10T1 GF10T2	GF10T3 GF10T4 GF10T5	GF10T1G GF10T2G	GF10T3G GF10T4G GF10T5G	GF10T1V GF10T2V	GF10T3V
	Media	Air					
Operation method	Internal pilot type		External pilot type (for positive pressure)		External pilot type (for vacuum)		
Effective area (Cv) ^{Note 1}	mm ²	5 (0.28)	4.5 (0.25)	5 (0.28)	4.5 (0.25)	5 (0.28)	4.5 (0.25)
Port size ^{Note 2}	M5×0.8, φ4, φ6 fitting, Rc1/8						
Lubrication	Not required						
Operating pressure range	Main valve	0.2~0.7MPa {2~7.1kgf/cm ² }		0~0.7MPa {0~7.1kgf/cm ² } ^{Note 3}		0.15MPa~100kPa {1.5kgf/cm ² ~750.1mmHg}	
	External pilot	—		0.2~0.7MPa {2~7.1kgf/cm ² } ^{Note 3}		0.2~0.7MPa {2~7.1kgf/cm ² }	
Proof pressure	MPa (kgf/cm ²)	1.05 (10.7)					
Response time ^{Note 4}	DC12V, DC24V	15/20, {20}	15/30	15/20, {20}	15/30	15/20, {20}	15/30
	AC100V, AC200V	15/15, {20}	15/25	15/15, {20}	15/25	15/15, {20}	15/25
Maximum operating frequency	Hz	5					
Minimum time to energize for self holding ^{Note 5}	ms	50	—	50	—	50	—
Operating temperature range (atmosphere and media)	°C	5~50					
Shock resistance	m/s ² (G)	1373 {140.0}	294.2 {30.0}	1373 {140.0}	294.2 {30.0}	1373 {140.0}	294.2 {30.0}
		[pilot valve axial direction 294.2 {30.0}]		[pilot valve axial direction 294.2 {30.0}]		[pilot valve axial direction 294.2 {30.0}]	
Mounting direction	Any						

Notes: 1. For details, see the effective area on p.463.

2. For details, see the port size on p.463.

3. When the main valve pressure is 0.2~0.7MPa, set the external pilot pressure to the main valve pressure or higher and to 0.7 MPa or less.

4. Values when air pressure is 0.5MPa. Values in brackets () are for T2. And the values for 3-position valves are those switching from the neutral position.
For switching phase timing, add a maximum of 5 ms to the response time of AC specification.

5. For the double solenoid.

Remark: Conversion to psi., 1Mpa=145psi., 1kgf/cm²=14.2psi., e.g. 0.2Mpa=29psi.

Solenoid Specifications

Item	Rated voltage	DC12V	DC24V	AC100V ^{Note}	AC200V ^{Note}
	Operating voltage range	V	10.8~13.2 (12±10%)	21.6~26.4 (24±10%)	90~110 (100±10%)
Rated frequency	Hz	—	—	50 60	50 60
Current (When rated voltage is applied)	mA (r.m.s)	42	21	11	8
Power consumption		0.5W	0.5W	1.1VA	1.6VA
Allowable leakage current	mA	1.0	1.0	1.0	1.0
Insulation resistance	MΩ	Min. 100 (value at DC500V megger)			
Wiring and lead wire length		Grommet type: 300mm Plug connector type: 300mm,3000mm			
Color of lead wire		Red (+), Black (-)		Yellow	White
Color of LED indicator		Red			
Surge suppression (as standard)		Flywheel diode		Bridge diode	

Notes: 1. Since the AC types have built-in bridge diodes, the starting current value and energizing current value are virtually the same.

2. For long time continuous energizing of AC types, consult us.

3. Provide heat radiation measures to ensure that the ambient temperature (or when using a control box, the internal temperature of the box) always remains within the temperature range specifications.

Cylinder Operating Speed

How to obtain cylinder speed

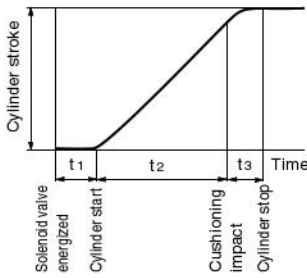

Measurement conditions

- Air pressure: 0.5MPa [5.1kgf/cm²]
- Piping (outer diameter X inner diameter X length): φ6 X φ4 X 1000mm
- Fitting: Quick fitting TS6-01
- Load ratio = $\frac{\text{Load}}{\text{Cylinder theoretical thrust}} (\%)$
- Cylinder stroke: 150mm

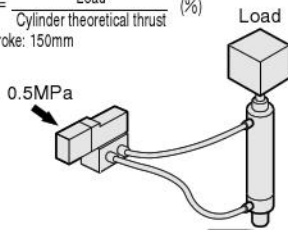

Maximum operating speed

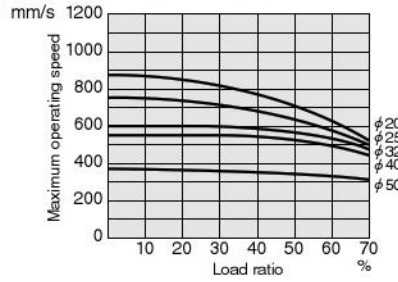

Delay time

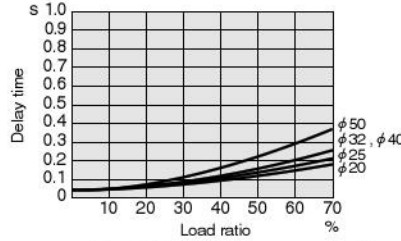

Note: Delay time may vary according to the cylinder stroke

Flow Rate

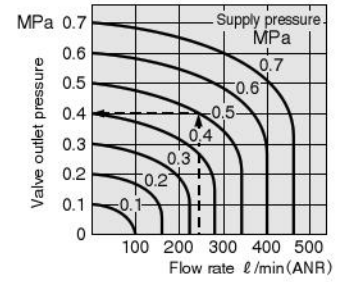

How to read the graph

If supply pressure is 0.5MPa and flow rate is 240 l/min (ANR), the valve outlet pressure becomes 0.4MPa.

Discontinued

Port Size

● GF10 Series

Item/Piping specification		PR	P2	A, B	P, R
With sub-base		M5×0.8	M5×0.8	Rc 1/8	Rc 1/8
Single unit	With female thread block	—	—	M5×0.8	M5×0.8
	With fitting block	—	—	φ4, φ6	M5×0.8
Manifold	Monoblock type (with female thread block, female thread specification)	M5×0.8	M5×0.8	M5×0.8	Rc 1/8
	Monoblock type (with fitting block, fitting specification)	M5×0.8	M5×0.8	φ4, φ6	Rc 1/8
	Split type with female thread block	—	M5×0.8	M5×0.8	Rc 1/4
	Split type with fitting block	—	M5×0.8	φ4, φ6	φ8

Effective Area [Cv]

● When using as a single unit mm²

Basic model	Effective Area [Cv]
GF10T1□-A2 GF10T2□-A2	5.0 [0.28]
GF10T3□-A2 GF10T4□-A2 GF10T5□-A2	4.5 [0.25]
GF10T1□-F4 GF10T2□-F4	3.8 [0.21]
GF10T3□-F4 GF10T4□-F4 GF10T5□-F4	3.5 [0.19]
GF10T1□-F5 GF10T2□-F5 GF10T3□-F5 GF10T4□-F5 GF10T5□-F5	3.5 [0.19]
GF10T1□-F6 GF10T2□-F6 GF10T3□-F6 GF10T4□-F6 GF10T5□-F6	3.5 [0.19]

● When mounted on the manifold mm²

Valve model		Manifold model					
		GF10M□F	GF10M□FC	GF10M□A	GF10M□AC	GF10M□N	
GF10T1□ GF10T2□	Output port	4.5 [0.25]	4.0 [0.22]	4.0 [0.22]	3.5 [0.19]	5.0 [0.28]	
GF10T3□ GF10T4□ GF10T5□		Female thread	4.5 [0.25]	4.0 [0.22]	4.0 [0.22]	3.5 [0.19]	4.5 [0.25]
GF10T1□ GF10T2□	Output port	3.5 [0.19]	3.5 [0.19]	3.3 [0.18]	3.3 [0.18]	4.3 [0.24]	
GF10T3□ GF10T4□		φ4 fitting φ6 fitting	3.5 [0.19]	3.5 [0.19]	3.3 [0.18]	3.3 [0.18]	3.8 [0.21]
GF10T5□							

Mass

Single Valve Unit Mass

g

Valve specification	Model	GF10T□□	GF10T□□-A1	GF10T□□-A2	GF10T□□-FJ5	GF10T□□-FJ6	GF10T□□-FM	GF10T□□-F4	GF10T□□-F5	GF10T□□-F6
	Output section	Output section None	Output section With plate	Output section With plate	Output section With φ 4 fitting block	Output section With φ 6 fitting block	Output section With female thread block	Output section With female thread block	Output section With φ 4 fitting block	Output section With φ 6 fitting block
	Input section	Input section None	Input section None	Input section With A type sub-base	Input section None	Input section None	Input section None	Input section With female thread block	Input section With female thread block	Input section With female thread block
T1		33	36	105	47	49	40	48	54	57
T2		49	52	121	62	65	56	64	70	73
T3, T4, T5		51	54	123	64	67	58	66	72	75

Block-off plate: 5.1g

Monoblock Manifold Mass

g

Monoblock manifold	Mass calculation of each unit (n=number of units)			Additional mass
Monoblock manifold A type	Manifold A, B port output specification			70
	With female thread block	-J5 with φ 4 fitting block	-J6 with φ 6 fitting block	
	(50×n)	(57×n)	(59×n)	
Monoblock manifold F type	(25×n)			70

Calculation example: **GF10M8AJ**

stn.1~stn.8 GF10T1-A1-PS-J5 DC24V

$$(57 \times 7) + 7 + (36 \times 8) = 814\text{g}$$

Discontinued

Monoblock Compact Manifold Mass

g

Monoblock compact manifold	Mass calculation of each unit (n=number of units)			Additional mass
Monoblock compact manifold A type	Manifold A, B port output specification			57
	Female thread specification	-J5 with φ 4 fitting specification	-J6 with φ 6 fitting specification	
	(35×n)	(42×n)	(44×n)	
Monoblock compact manifold F type	(18×n)			44

Calculation example: **GF10M8ACJ**

stn.1~stn.8 GF10T1-A1-PS-J5 DC24V

$$(42 \times 8) + 57 + (36 \times 8) = 681\text{g}$$

Split Type Manifold Mass

g

Split type manifold	Mass calculation of each unit (n=number of units)			Additional mass		
Base piping type	Manifold A, B port output specification			Piping block		End block
	With female thread block	-J5 with φ 4 fitting block	-J6 with φ 6 fitting block	With female thread	With fitting block	
	(25×n)	(32×n)	(34×n)	141	182	
Direct piping type	(21×n)			141	182	156

Calculation example: **GF10M8NJ-JR**

stn.1~stn.8 GF10T1-A1-PS-J5 DC24V

$$(32 \times 8) + 182 + 156 + (36 \times 8) = 882\text{g}$$

GF10 Series Dimensions of Single Valve Unit (Scale 1/3, Unit mm)

GF10T1-F5-PS

With output port fitting block
With input port female thread block
S type plug connector

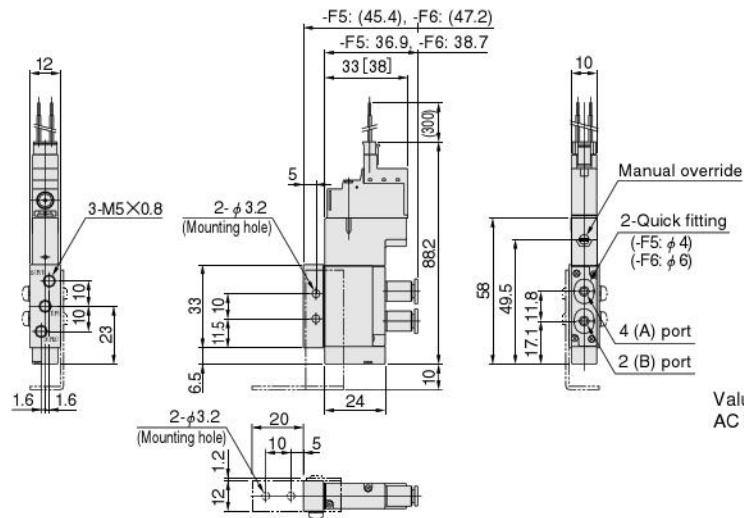

Values in brackets [] are for AC 200V specification.

GF10T2-F5-PS

With output port fitting block
With input port female thread block
S type plug connector

Discontinued

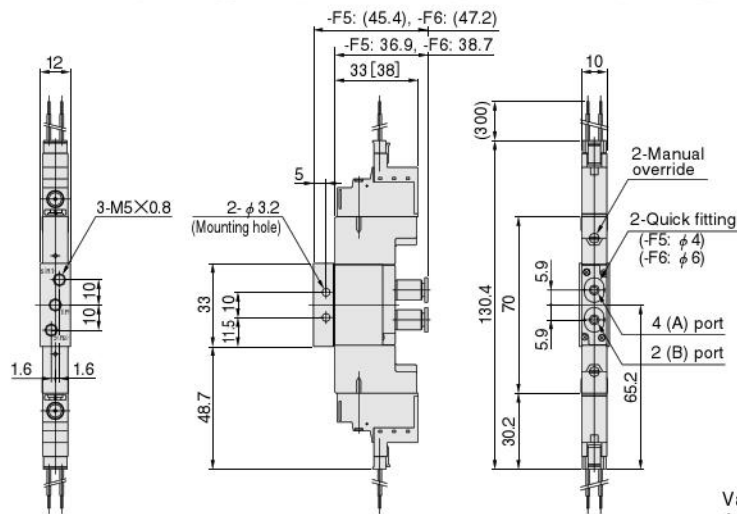

Values in brackets [] are for AC 200V specification.

GF10T3-F5-PS

GF10T4-F5-PS

GF10T5-F5-PS

With output port fitting block
With input port female thread block
S type plug connector

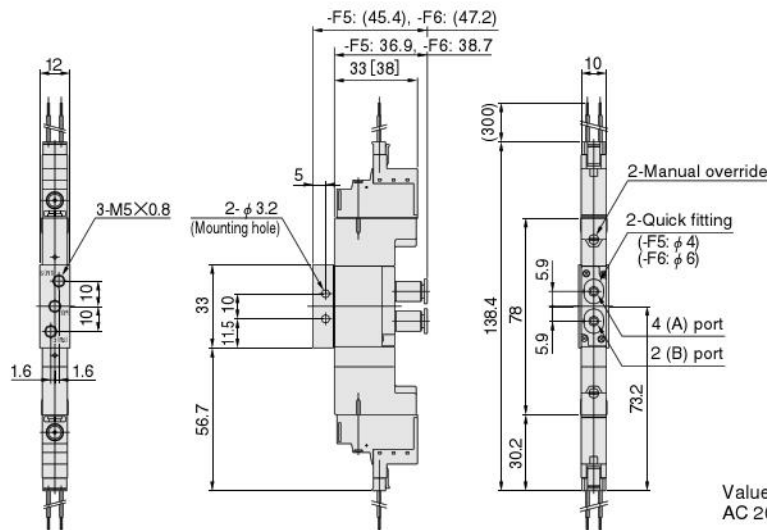

Values in brackets [] are for AC 200V specification.

GF10 Series Dimensions of Single Valve Unit (Scale 1/3, Unit mm)

GF10T1-F4-PS

With output port female thread block
With input port female thread block
S type plug connector

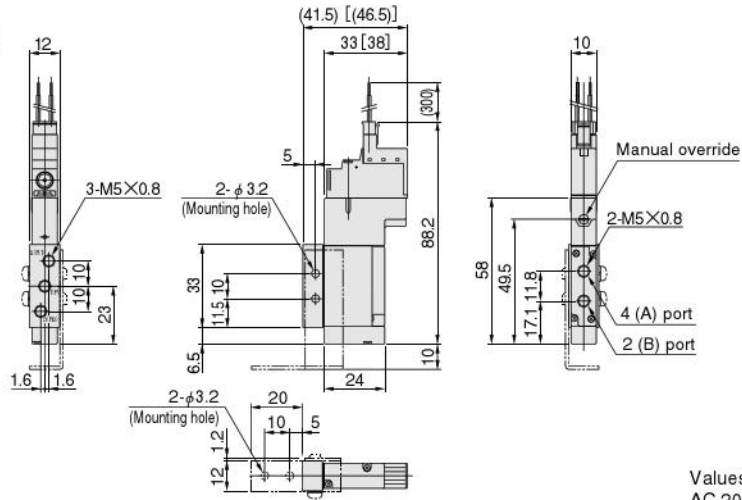
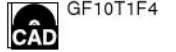

Values in brackets [] are for AC 200V specification.

GF10T2-F4-PS

With output port female thread block
With input port female thread block
S type plug connector

Discontinued

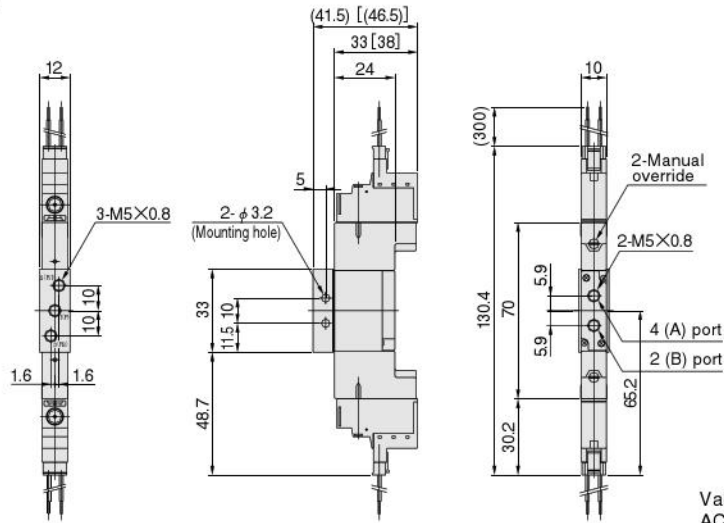

Values in brackets [] are for AC 200V specification.

GF10T3-F4-PS

GF10T4-F4-PS

GF10T5-F4-PS

With output port female thread block
With input port female thread block
S type plug connector

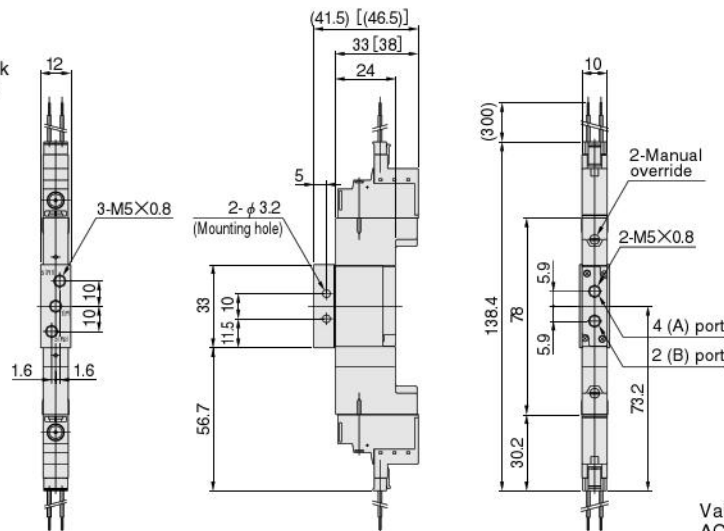
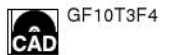

Values in brackets [] are for AC 200V specification.

External pilot specification

GF10T1G-A2-PS

With A type sub-base
S type plug connector

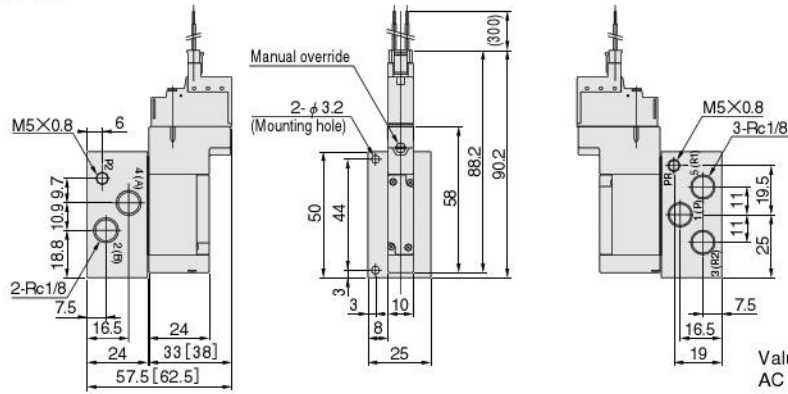

Values in brackets [] are for AC 200V specification.

Discontinued

Wiring



● When mounting DC12V, DC24V, AC100V

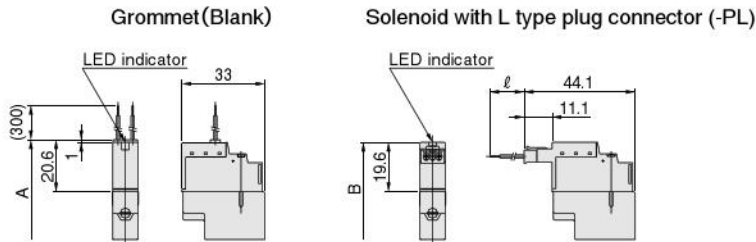

● When mounting AC200V

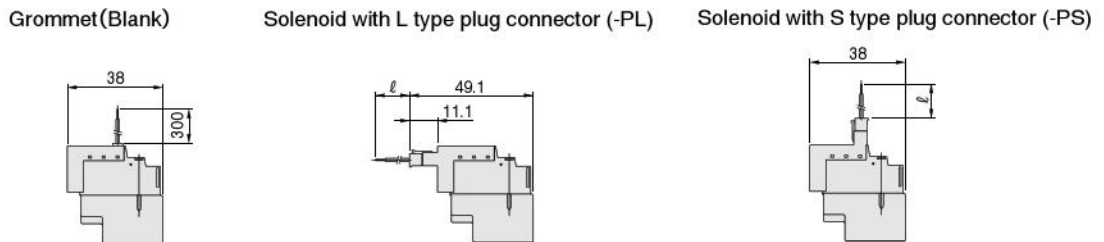

Code	A	B	ℓ (lead wire length)	Remarks
Model				
GF10T1	78.6	77.6	Standard: 300 -P□3: 3000	Length to the end of the valve
GF10T2	111.2	109.2		Total length to the end of the opposite solenoid
GF10T3, 4, 5	119.2	117.2		

GF10 Series Dimensions of Monoblock Manifold A Type and F Type (Scale 1/3, Unit mm)

GF10M Number of units **A** **M** Pilot specification (base piping type)



Monoblock manifold A type
With manifold output port fitting block
S type plug connector

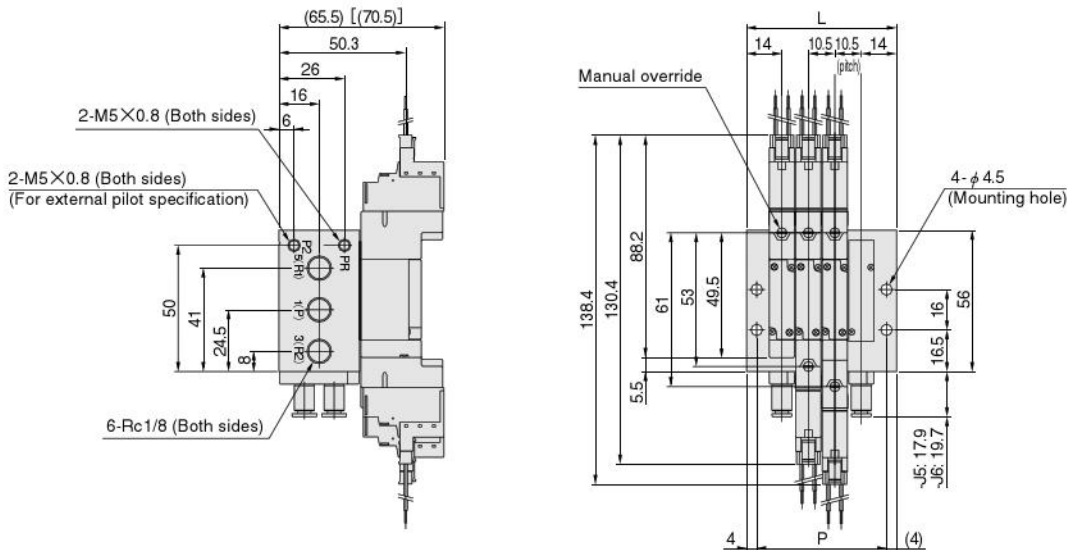

Unit dimensions

Number of units	L	P
2	38.5	30.5
3	49.0	41.0
4	59.5	51.5
5	70.0	62.0
6	80.5	72.5
7	91.0	83.0
8	101.5	93.5
9	112.0	104.0
10	122.5	114.5
11	133.0	125.0
12	143.5	135.5
13	154.0	146.0
14	164.5	156.5
15	175.0	167.0
16	185.5	177.5
17	196.0	188.0
18	206.5	198.5
19	217.0	209.0
20	227.5	219.5

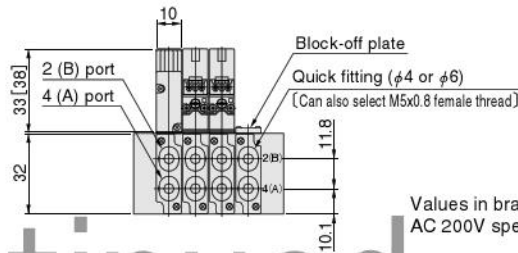

Values in brackets [] are for AC 200V specification.

GF10M Number of units **F** (direct piping type)

Monoblock manifold F type
With valve output port fitting block
S type plug connector

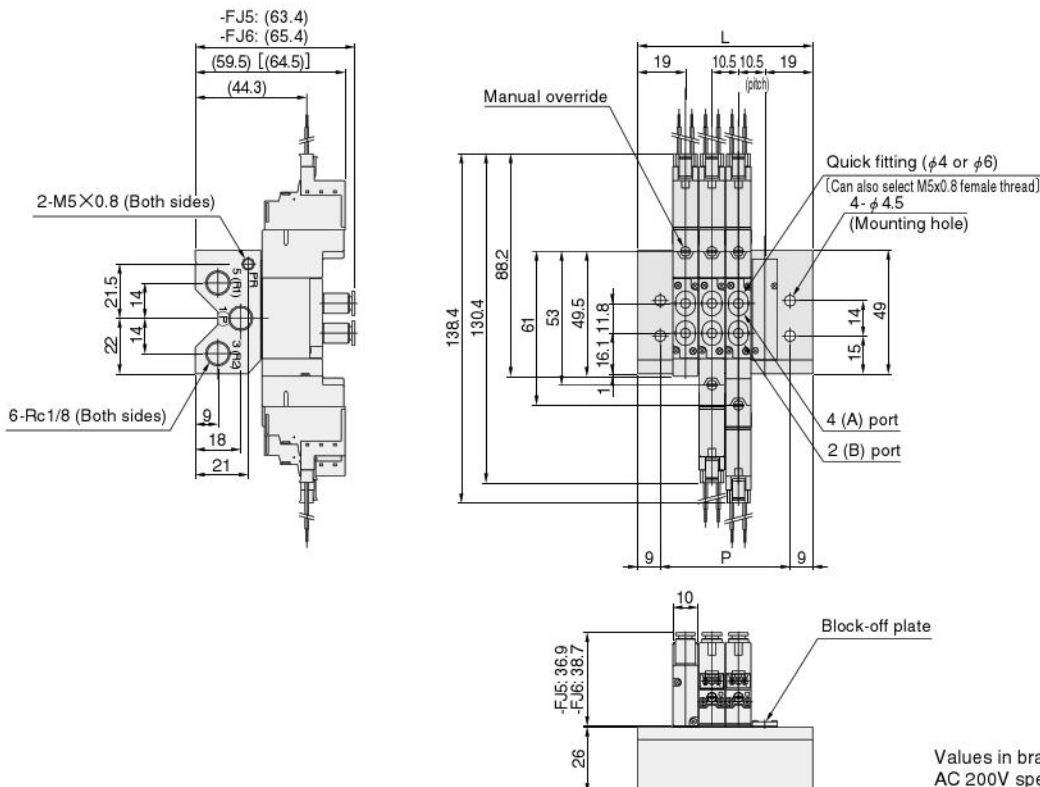

Unit dimensions

Number of units	L	P
2	48.5	30.5
3	59.0	41.0
4	69.5	51.5
5	80.0	62.0
6	90.5	72.5
7	101.0	83.0
8	111.5	93.5
9	122.0	104.0
10	132.5	114.5
11	143.0	125.0
12	153.5	135.5
13	164.0	146.0
14	174.5	156.5
15	185.0	167.0
16	195.5	177.5
17	206.0	188.0
18	216.5	198.5
19	227.0	209.0
20	237.5	219.5

Values in brackets [] are for AC 200V specification.

Discontinued

GF10 Series Dimensions of Monoblock Compact Manifold A Type and F Type (Scale 1/3, Unit mm)

GF10M Number of units AC ^J_M

Monoblock compact manifold A type
With manifold output port fitting
S type plug connector

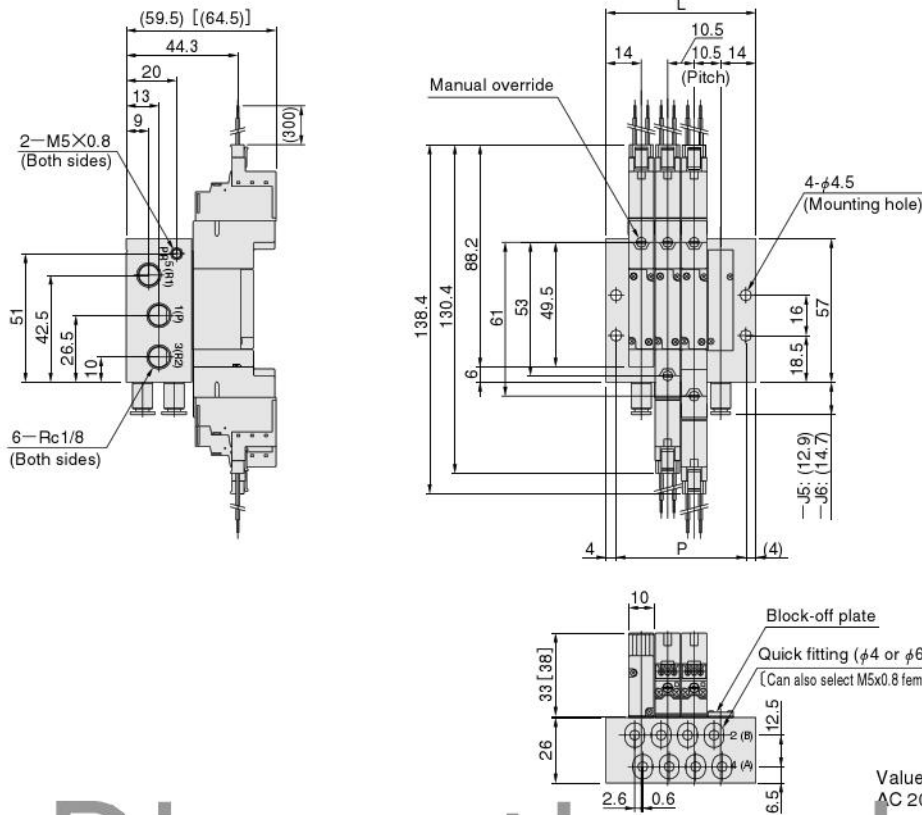

Unit dimensions

Number of units	L	P
2	38.5	30.5
3	49.0	41.0
4	59.5	51.5
5	70.0	62.0
6	80.5	72.5
7	91.0	83.0
8	101.5	93.5
9	112.0	104.0
10	122.5	114.5
11	133.0	125.0
12	143.5	135.5
13	154.0	146.0
14	164.5	156.5
15	175.0	167.0
16	185.5	177.5
17	196.0	188.0
18	206.5	198.5
19	217.0	209.0
20	227.5	219.5

GF10M Number of units FC

Monoblock compact manifold F type
With valve output port fitting block
S type plug connector

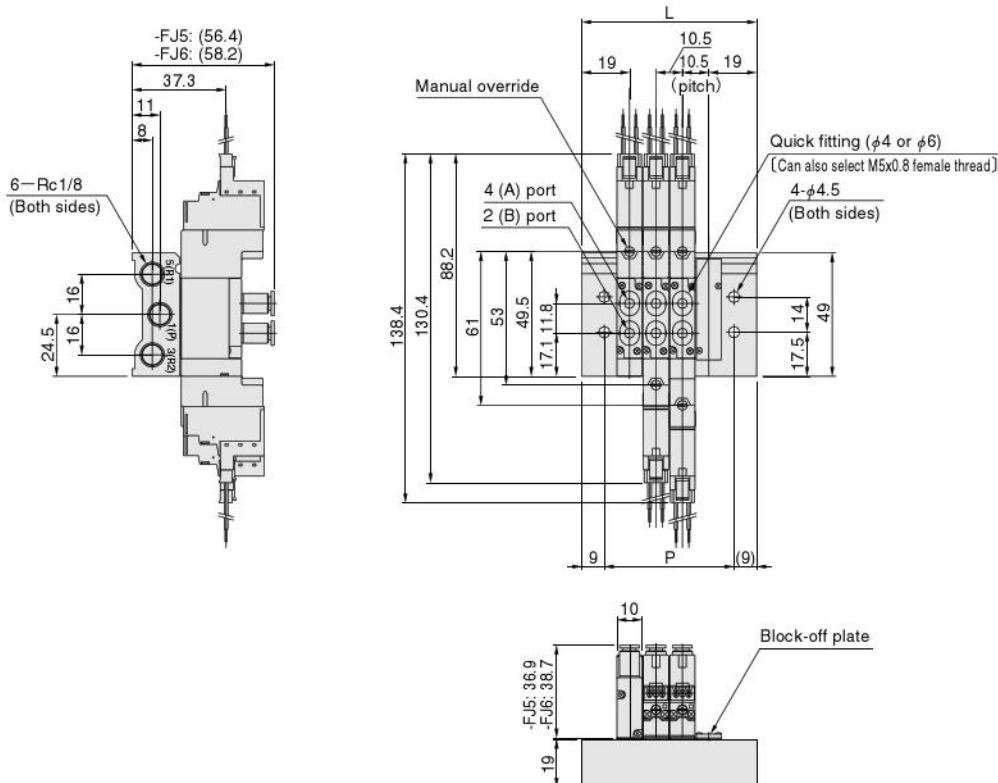

Unit dimensions

Number of units	L	P
2	48.5	30.5
3	59.0	41.0
4	69.5	51.5
5	80.0	62.0
6	90.5	72.5
7	101.0	83.0
8	111.5	93.5
9	122.0	104.0
10	132.5	114.5
11	143.0	125.0
12	153.5	135.5
13	164.0	146.0
14	174.5	156.5
15	185.0	167.0
16	195.5	177.5
17	206.0	188.0
18	216.5	198.5
19	227.0	209.0
20	237.5	219.5

GF10 Series Dimensions of Split Manifold, Non-Plug-in Type (Scale 1/3, Unit mm)

GF10M N Pilot specification (base piping type)



With manifold output port fitting block
S type plug connector

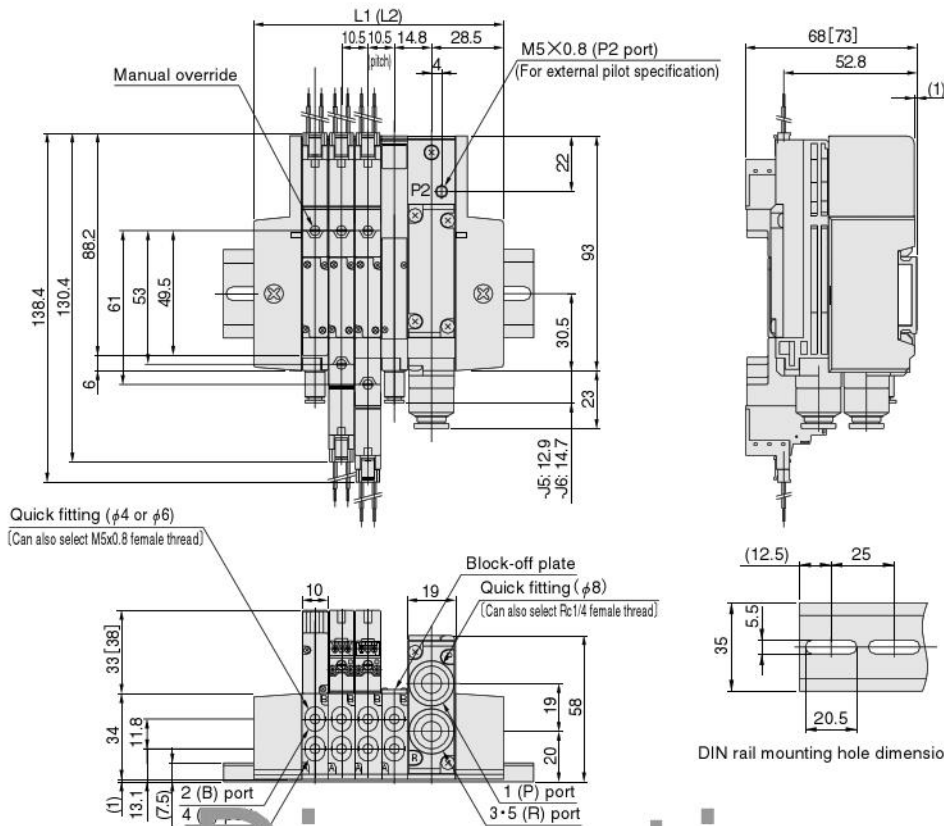

Unit dimensions

Number of units	L1	DIN rail length	L2 Note	DIN rail length Note
2	78.0	125	97.0	125
3	88.5	125	107.5	150
4	99.0	125	118.0	150
5	109.5	150	128.5	175
6	120.0	150	139.0	175
7	130.5	175	149.5	175
8	141.0	175	160.0	200
9	151.5	200	170.5	200
10	162.0	200	181.0	225
11	172.5	200	191.5	225
12	183.0	225	202.0	250
13	193.5	225	212.5	250
14	204.0	250	223.0	250
15	214.5	250	233.5	275
16	225.0	275	244.0	275
17	235.5	275	254.5	300
18	246.0	275	265.0	300
19	256.5	300	275.5	325
20	267.0	300	286.0	325

Note: When using two piping blocks.

Values in brackets [] are for AC 200V specification.

GF10M N Pilot specification (direct piping type)



With valve output port fitting block
S type plug connector

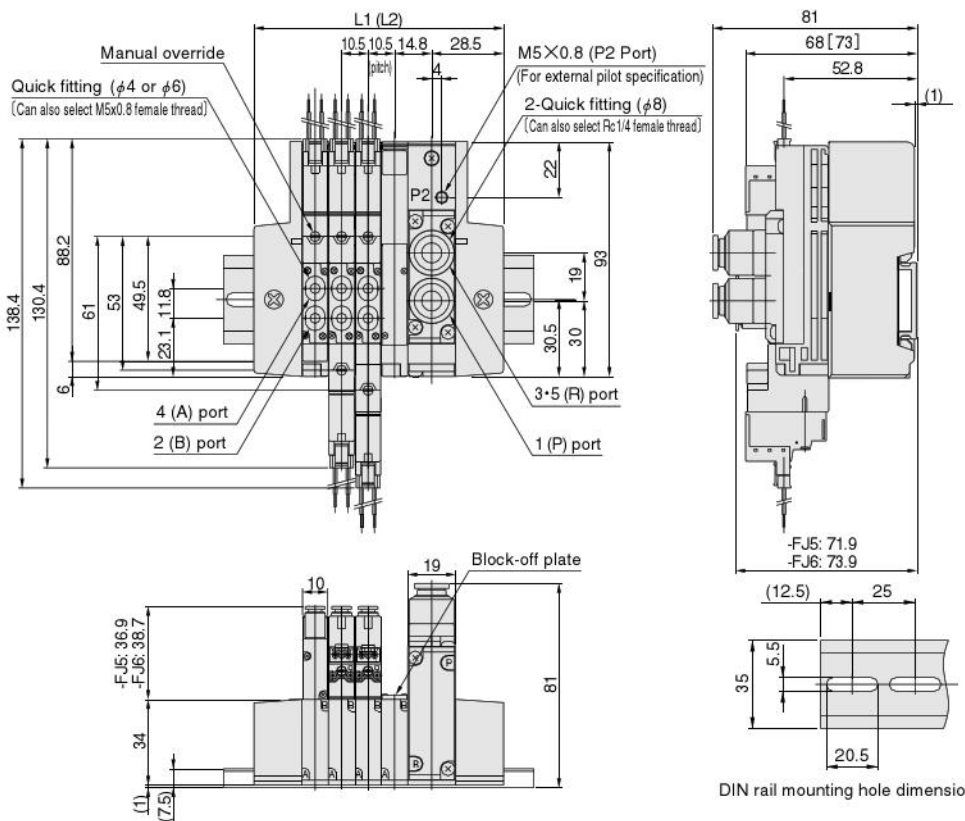

Unit dimensions

Number of units	L1	DIN rail length	L2 Note	DIN rail length Note
2	78.0	125	97.0	125
3	88.5	125	107.5	150
4	99.0	125	118.0	150
5	109.5	150	128.5	175
6	120.0	150	139.0	175
7	130.5	175	149.5	175
8	141.0	175	160.0	200
9	151.5	200	170.5	200
10	162.0	200	181.0	225
11	172.5	200	191.5	225
12	183.0	225	202.0	250
13	193.5	225	212.5	250
14	204.0	250	223.0	250
15	214.5	250	233.5	275
16	225.0	275	244.0	275
17	235.5	275	254.5	300
18	246.0	275	265.0	300
19	256.5	300	275.5	325
20	267.0	300	286.0	325

Note: When using two piping blocks.

Values in brackets [] are for AC 200V specification.

Female Thread Specification (Scale 1/3, Unit mm)

● Split manifold non-plug-in type

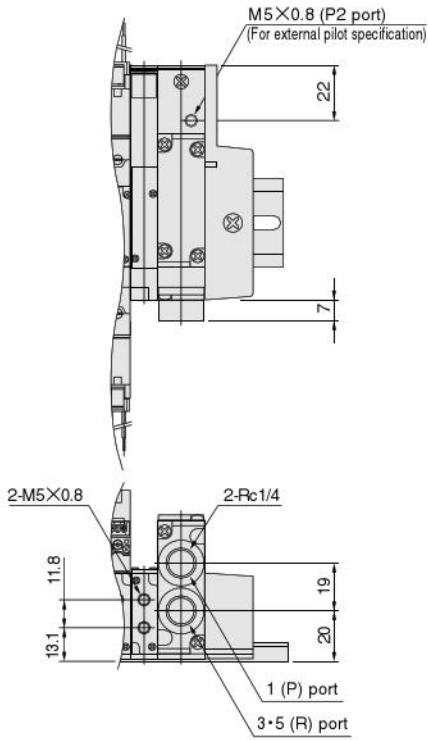

● Monoblock compact manifold A type

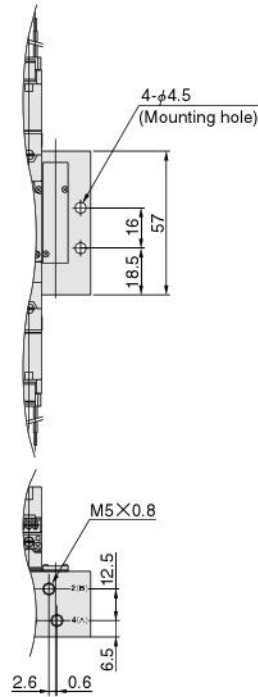

Additional Part: (Sold Separately)

● Muffler: **KM-J8**

(Scale 2/3, Unit mm)

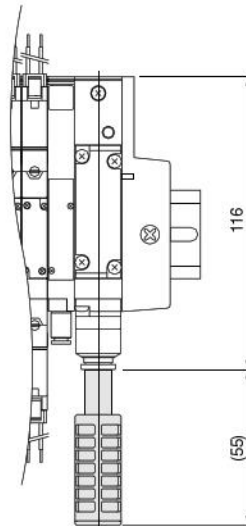
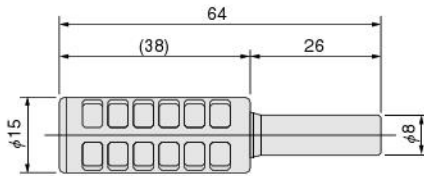

SOLENOID VALVES GF15 SERIES

INDEX

Specifications	474
Dimensions of Single Valve Unit	477
Dimensions of Monoblock Manifold	481
Dimensions of Monoblock Compact Manifold	482
Dimensions of Split Non-Plug-in Type	483



Discontinued

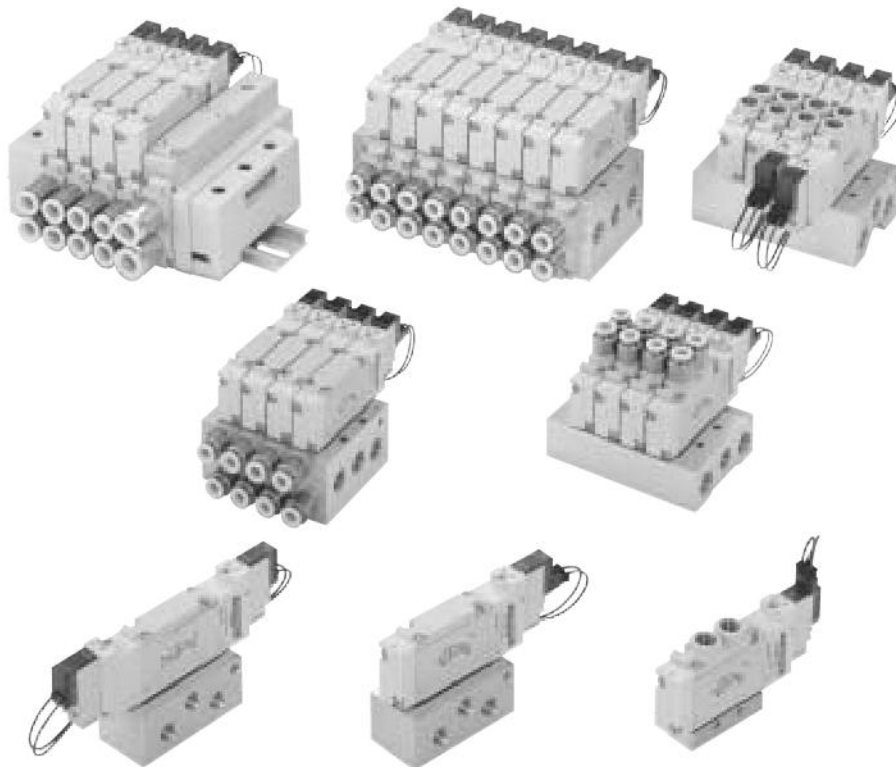

GF15 SERIES SPECIFICATIONS

Specifications

Basic Models and Valve Functions

Item	Basic model	GF15T1 GF15T2	GF15T3 GF15T4 GF15T5
	Number of positions		2 positions
Number of ports		5	
Valve function		Single solenoid or double solenoid	All port block, ABR connection or PAB connection

Remarks: For optional specifications and order code, see p.448~459.

Specifications

Item	Basic model	GF15T1 GF15T2	GF15T3 GF15T4 GF15T5	GF15T1G GF15T2G	GF15T3G GF15T4G GF15T5G	GF15T1V GF15T2V	GF15T3V
	Media		Air		Air		Air
Operation method		Internal pilot type		External pilot type (for positive pressure)		External pilot type (for vacuum)	
Effective area (Cv) ^{Note 1}	mm ²	10 [0.56]					
Port size ^{Note 2}		φ 6, φ 8 fitting, Rc1/8		M5×0.8, φ 6, φ 8 fitting, Rc1/8			
Lubrication		Not required					
Operating pressure range	Main valve	0.15~0.7MPa {1.5~7.1kgf/cm ² }		0~0.7MPa {0~7.1kgf/cm ² } ^{Note 3}		0.15MPa~100kPa {1.5kgf/cm ² ~750.1mmHg}	
	External pilot	—		0.2~0.7MPa {2~7.1kgf/cm ² } ^{Note 3}		0.2~0.7MPa {2~7.1kgf/cm ² }	
Proof pressure	MPa {kgf/cm ² }	1.05 [10.7]					
Response time ^{Note 4}	DC12V, DC24V	20/35, [25]	15/50	20/35, [25]	15/50	20/35, [25]	15/50
	AC100V, AC200V	20/25, [20]	15/40	20/25, [20]	15/40	20/25, [20]	15/40
ON/OFF	ms						
Maximum operating frequency	Hz	5					
Minimum time to energize for self holding ^{Note 5}	ms	50	—	50	—	50	—
Operating temperature range (atmosphere and media)	°C	5~50					
Shock resistance	m/s ² [G]	1373 [140.0]	294.2 [30.0]	1373 [140.0]	294.2 [30.0]	1373 [140.0]	294.2 [30.0]
		[pilot valve axial direction]		[pilot valve axial direction]		[pilot valve axial direction]	
Mounting direction		Any					

Notes: 1. For details, see the effective area on p.475.

2. For details, see the port size on p.475.

3. When the main valve pressure is 0.2~0.7MPa, set the external pilot pressure to the main valve pressure or higher and to 0.7 MPa or less.

4. Values when air pressure is 0.5MPa. Values in brackets [] are for T2. And the values for 3-position valves are those switching from the neutral position. For switching phase timing, add a maximum of 5 ms to the response time in AC specification.

5. For the double solenoid.

Remark: Conversion to psi., 1Mpa=145psi., 1kgf/cm²=14.2psi., e.g. 0.15Mpa=21.8psi.

Solenoid Specifications

Item	Rated voltage	DC12V	DC24V	AC100V ^{Note}	AC200V ^{Note}
	Operating voltage range	V	10.8~13.2 (12±10%)	21.6~26.4 (24±10%)	90~110 (100±10%)
Rated frequency	Hz	—	—	50 60	50 60
Current (When rated voltage is applied)	mA (r.m.s)	42	21	11	8
Power consumption		0.5W	0.5W	1.1VA	1.6VA
Allowable leakage current	mA	1.0	1.0	1.0	1.0
Insulation resistance	MΩ	Min. 100 (value at DC500V megger)			
Wiring and lead wire length		Grommet type: 300mm Plug connector type: 300mm, 3000mm			
Color of lead wire		Red (+), Black (-)		Yellow	White
Color of LED indicator		Red			
Surge suppression (as standard)		Flywheel diode		Bridge diode	

Notes: 1. Since the AC types have built-in bridge diodes, the starting current value and energizing current value are virtually the same.

2. For long time continuous energizing of AC types, consult us.

3. Provide heat radiation measures to ensure that the ambient temperature (or when using a control box, the internal temperature of the box) always remains within the temperature range specifications.

Cylinder Operating Speed

How to obtain cylinder speed

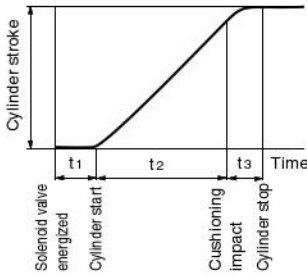

Measurement conditions

- Air pressure: 0.5MPa {5.1kgf/cm²}
- Piping (outer diameter X inner diameter X length):
φ8 X φ6 X 1000mm
- Fitting: Quick fitting TS8-01
- Load ratio = $\frac{\text{Load}}{\text{Cylinder theoretical thrust}}$ (%)
- Cylinder stroke: 150mm

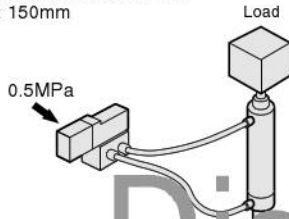

Maximum operating speed

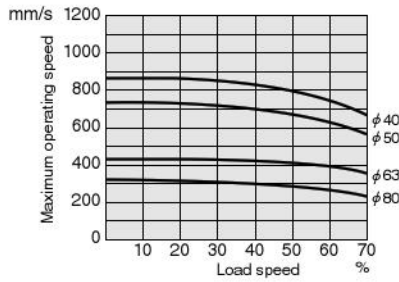

Delay time

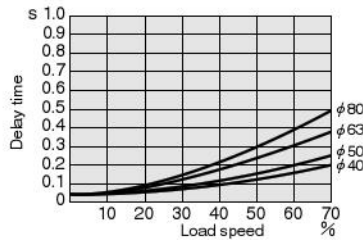

Note: Delay time may vary according to the cylinder stroke.

Flow Rate

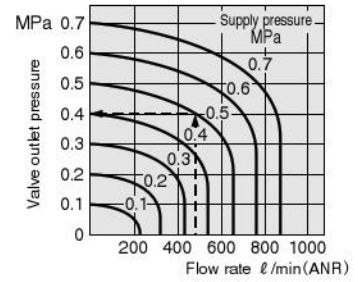

How to read the graph

If supply pressure is 0.5MPa and flow rate is 500 l/min (ANR), the valve outlet pressure becomes 0.4MPa.

Discontinued

Port Size

● GF15 Series

Item/Piping specification		PR	P2	A, B	P, R
With sub-base		M5 X 0.8	M5 X 0.8	Rc 1/8	Rc 1/8
Single unit	With female thread block	—	—	Rc 1/8	Rc 1/8
	With fitting block	—	—	φ 6, φ 8	Rc 1/8
Manifold	Monoblock type (with female thread block, female thread specification)	M5 X 0.8	M5 X 0.8	Rc 1/8	Rc 1/4
	Monoblock type (with fitting block, fitting specification)	M5 X 0.8	M5 X 0.8	φ 6, φ 8	Rc 1/4
	Split type with female thread block	—	M5 X 0.8	Rc 1/8	Rc 1/4
	Split type with fitting block	—	M5 X 0.8	φ 6, φ 8	φ 10

Effective Area [Cv]

● When using as a single unit

Basic model	Effective Area [Cv] mm ²
GF15T1□-A2 GF15T2□-A2 GF15T3□-A2 GF15T4□-A2 GF15T5□-A2	9.5 [0.53]
GF15T1□-F4 GF15T2□-F4 GF15T3□-F4 GF15T4□-F4 GF15T5□-F4	9.5 [0.53]
GF15T1□-F5 GF15T2□-F5 GF15T3□-F5 GF15T4□-F5 GF15T5□-F5	8.0 [0.44]
GF15T1□-F6 GF15T2□-F6 GF15T3□-F6 GF15T4□-F6 GF15T5□-F6	8.5 [0.47]

● When mounted on the manifold

Manifold model		mm ²				
Valve model		GF15M□F	GF15M□FC	GF15M□A	GF15M□AC	GF15M□N
GF15T1□ GF15T2□	Output port female thread	9.2 [0.51]	9.2 [0.51]	8.5 [0.47]	8.5 [0.47]	10.0 [0.56]
	GF15T3□ GF15T4□ GF15T5□	Output port φ 6 fitting	7.7 [0.43]	7.7 [0.43]	7.2 [0.40]	7.2 [0.40]
Output port φ 8 fitting		8.2 [0.45]	8.2 [0.45]	8.0 [0.44]	8.0 [0.44]	9.7 [0.54]

Mass

Single Valve Unit Mass

g

Valve specification	Model	GF15T□□	GF15T□□-A1	GF15T□□-A2	GF15T□□-FJ5	GF15T□□-FJ6	GF15T□□-FM	GF15T□□-F4	GF15T□□-F5	GF15T□□-F6
	Output section	Output section None	Output section With plate	Output section With plate	Output section With φ 6 fitting block	Output section With φ 8 fitting block	Output section With female thread block	Output section With female thread block	Output section With φ 6 fitting block	Output section With φ 8 fitting block
	Input section	Input section None	Input section None	Input section With A type sub-base	Input section None	Input section None	Input section None	Input section With female thread block	Input section With female thread block	Input section With female thread block
T1		70	89	201	114	118	93	108	120	134
T2		89	108	220	133	137	112	127	148	153
T3, T4, T5		95	113	225	138	143	117	133	154	158

Block-off plate: 14g

Monoblock Manifold Mass

g

Monoblock manifold	Mass calculation of each unit (n=number of units)			Additional mass
Monoblock manifold A type	Manifold A, B port output specification			127
	With female thread block	-J5 with φ 6 fitting block	-J6 with φ 8 fitting block	
	(131×n)	(150×n)	(156×n)	
Monoblock manifold F type	(58×n)			125

Calculation example: **GF15M8AJ**

stn.1~stn.8 GF15T1-A1-PS-J5 DC24V
 $(150 \times 8) + 127 + (89 \times 8) = 2039g$

Discontinued

Monoblock Compact Manifold Mass

g

Monoblock compact manifold	Mass calculation of each unit (n=number of units)			Additional mass
Monoblock compact manifold A type	Manifold A, B port output specification			71
	Female thread specification	-J5 with φ 4 fitting specification	-J6 with φ 6 fitting specification	
	(93×n)	(115×n)	(120×n)	
Monoblock compact manifold F type	(48×n)			86

Calculation example: **GF15M8ACJ**

stn.1~stn.8 GF15T1-A1-PS-J5 DC24V
 $(115 \times 8) + 71 + (89 \times 8) = 1703g$

Split Type Manifold Mass

g

Split type manifold	Mass calculation of each unit (n=number of units)			Additional mass		
Base piping type	Manifold A, B port output specification			Piping block		End block
	With female thread block	-J5 with φ 6 fitting block	-J6 with φ 8 fitting block	With female thread	With fitting block	
	(78×n)	(99×n)	(103×n)	150	204	
Direct piping type	(74×n)			150	204	124

Calculation example: **GF15M8NJ-JR**

stn.1~stn.8 GF15T1-A1-PS-J5 DC24V
 $(99 \times 8) + 204 + 124 + (89 \times 8) = 1832g$

GF15 Series Dimensions of Single Valve Unit (Scale 1/3, Unit mm)

GF15T1-F5-PS

With output port fitting block
With input port female thread block
S type plug connector

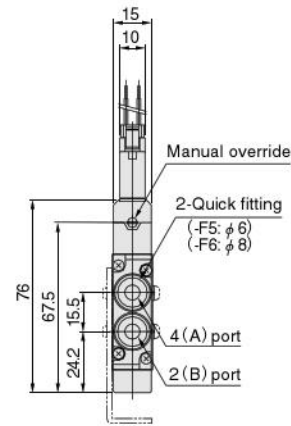
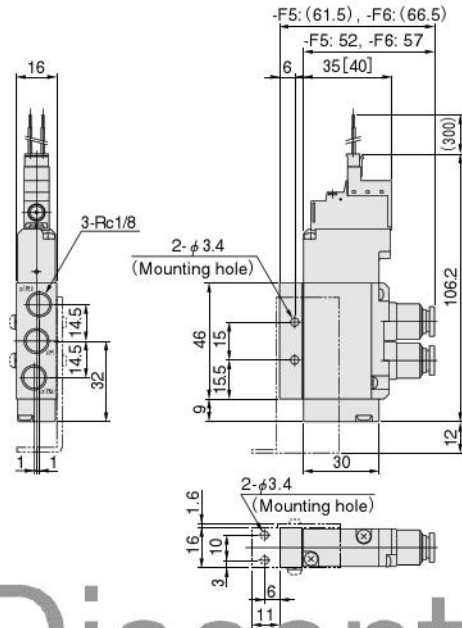

Values in brackets [] are for AC 200V specification.



Discontinued

GF15T2-F5-PS

With output port fitting block
With input port female thread block
S type plug connector

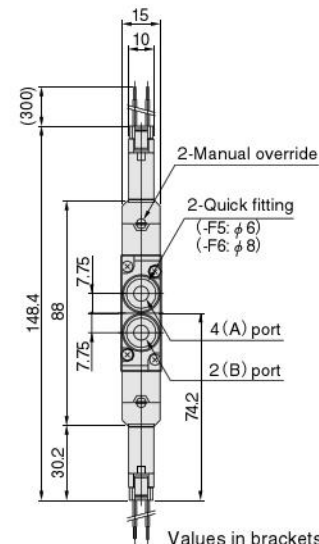
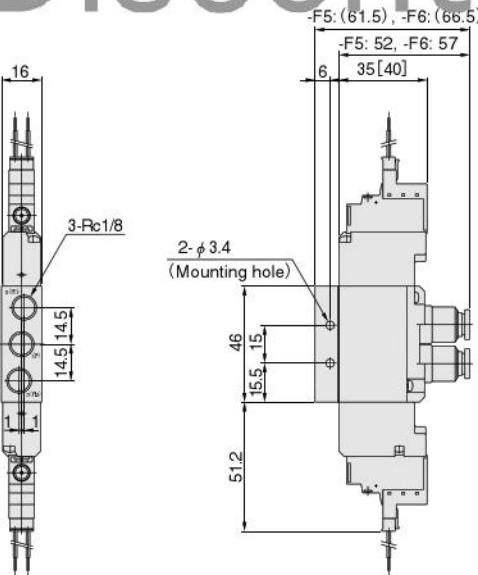

Values in brackets [] are for AC 200V specification.



GF15T3-F5-PS GF15T4-F5-PS GF15T5-F5-PS

With output port fitting block
With input port female thread block
S type plug connector

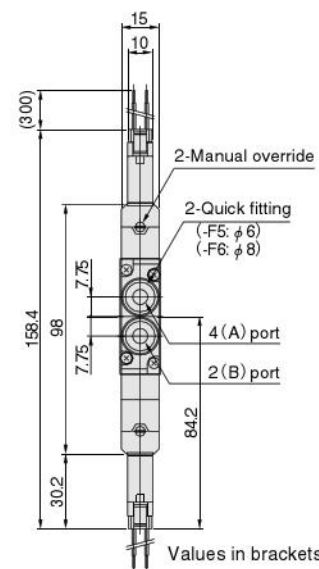
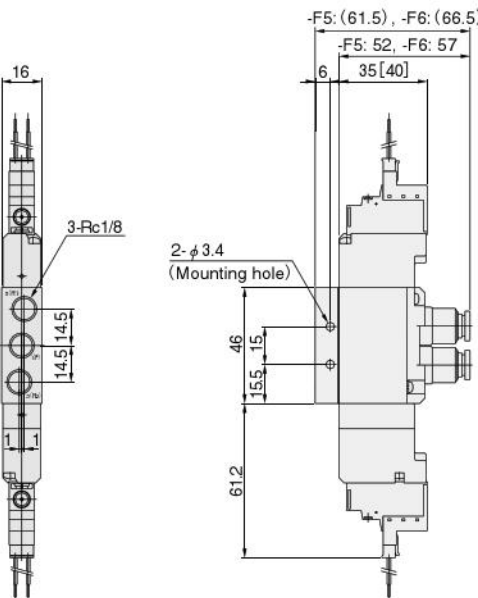

Values in brackets [] are for AC 200V specification.



GF15 Series Dimensions of Single Valve Unit (Scale 1/3, Unit mm)

GF15T1-F4-PS

With output port female thread block
With input port female thread block
S type plug connector

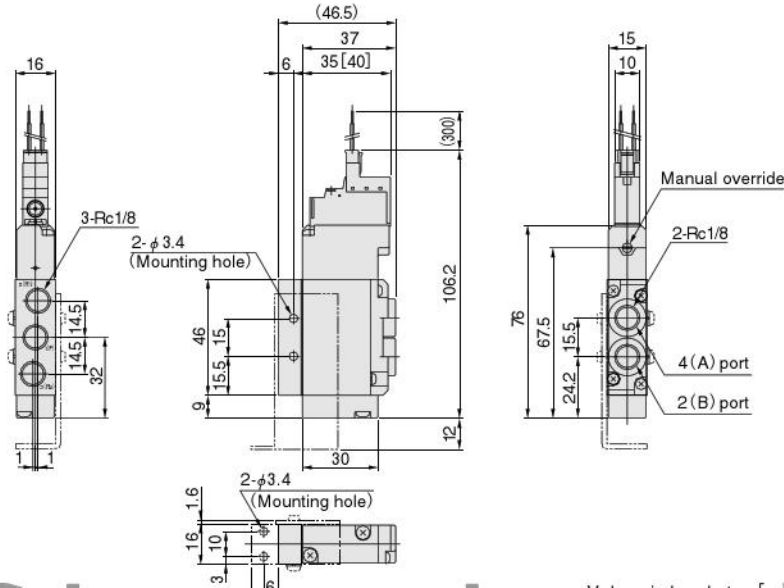

Discontinued

GF15T2-F4-PS

With output port female thread block
With input port female thread block
S type plug connector

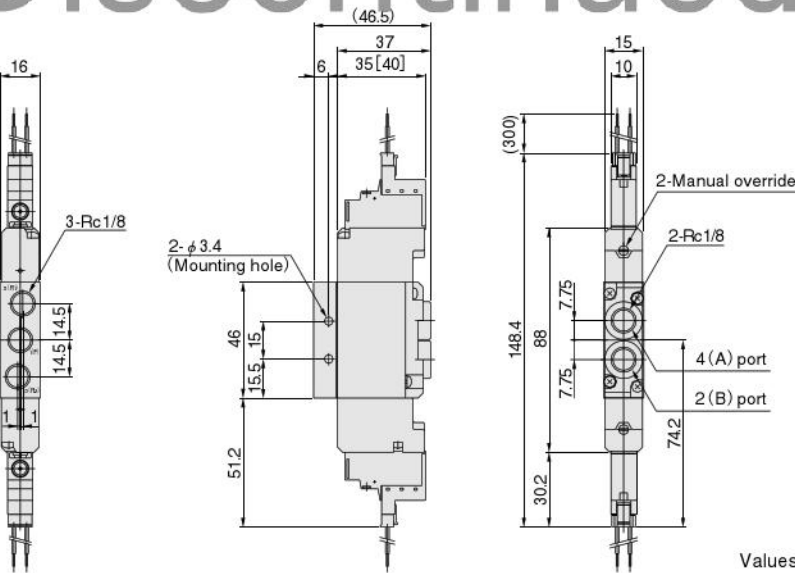

Values in brackets [] are for AC 200V specification.

GF15T3-F4-PS

GF15T4-F4-PS

GF15T5-F4-PS

With output port female thread block
With input port female thread block
S type plug connector

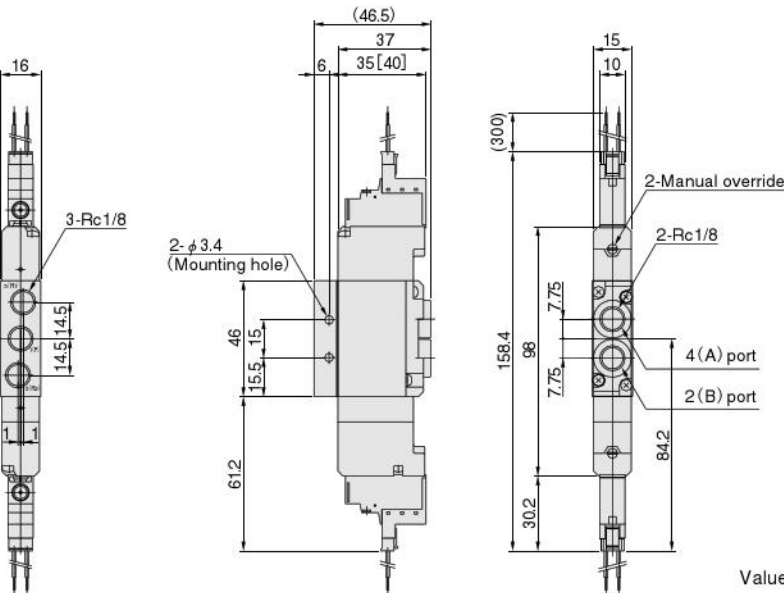

Values in brackets [] are for AC 200V specification.

GF15 Series Dimensions of Single Valve Unit (Scale 1/3, Unit mm)

GF15T1-A2-PS

With A type sub-base
S type plug connector

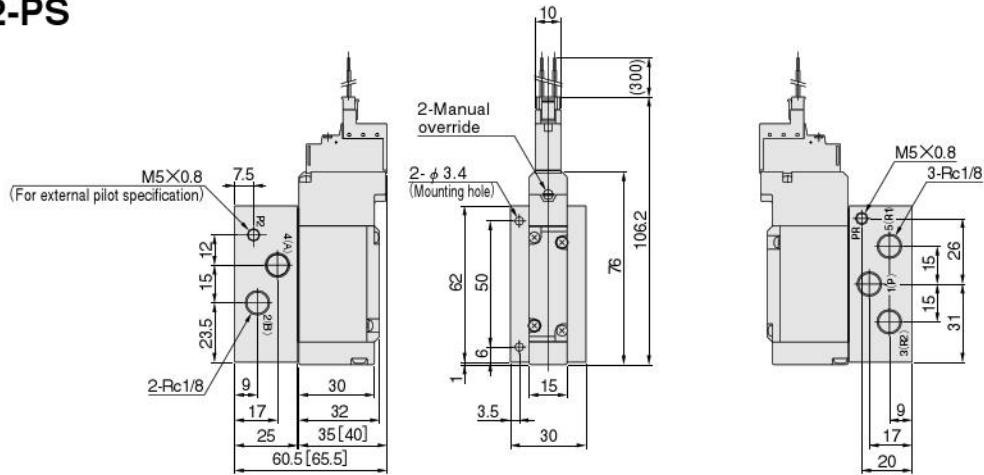

Values in brackets [] are for AC 200V specification.

GF15T2-A2-PS

With A type sub-base
S type plug connector

Discontinued

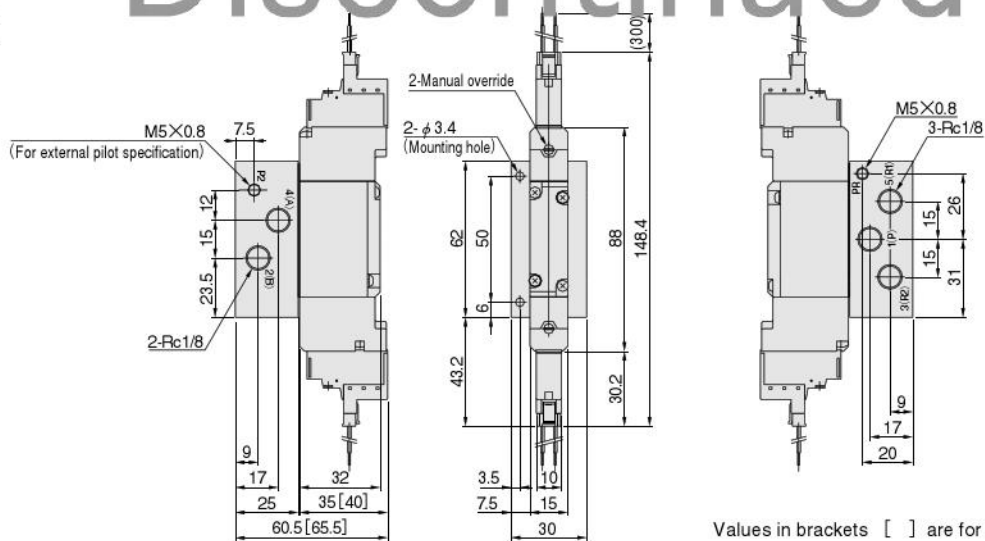

Values in brackets [] are for AC 200V specification.

GF15T3-A2-PS GF15T4-A2-PS GF15T5-A2-PS

With A type sub-base
S type plug connector

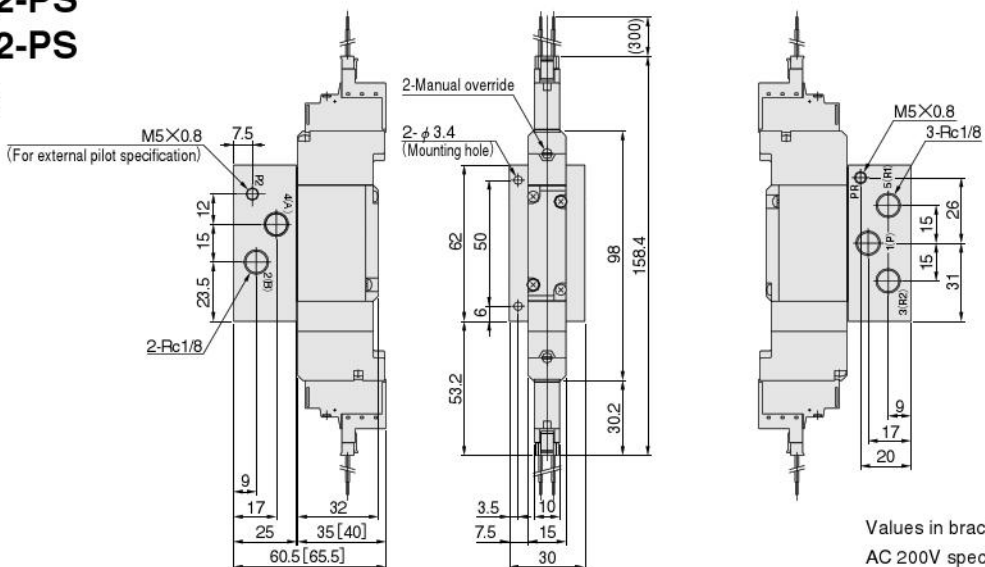

Values in brackets [] are for AC 200V specification.

Wiring



●When mounting DC12V, DC24V, AC100V

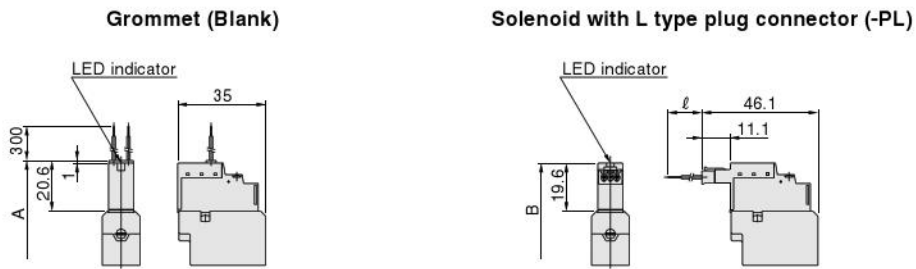

●When mounting AC200V

Grommet (Blank) Solenoid with L type plug connector (-PL) Solenoid with S type plug connector (-PS)

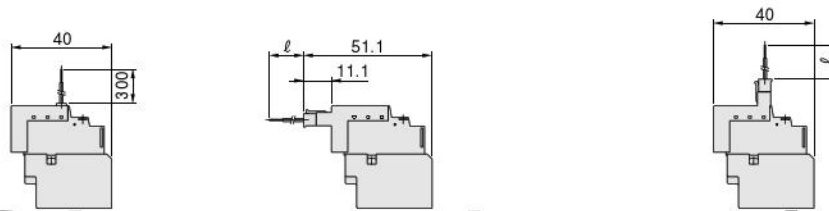

Discontinued

Code	A	B	ℓ (lead wire length)	Remarks
Model				
GF15T1	96.6	95.6	Standard: 300 -P□3: 3000	Length to the end of the valve
GF15T2	129.2	127.2		Total length to the end of the opposite solenoid
GF15T3, 4, 5	139.2	137.2		

GF15 Series Dimensions of Monoblock Manifold A Type and F Type (Scale 1/3, Unit mm)

GF15M Number of units **A_M** Pilot specification (base piping type)



Monoblock manifold A type
With manifold output port fitting block
S type plug connector

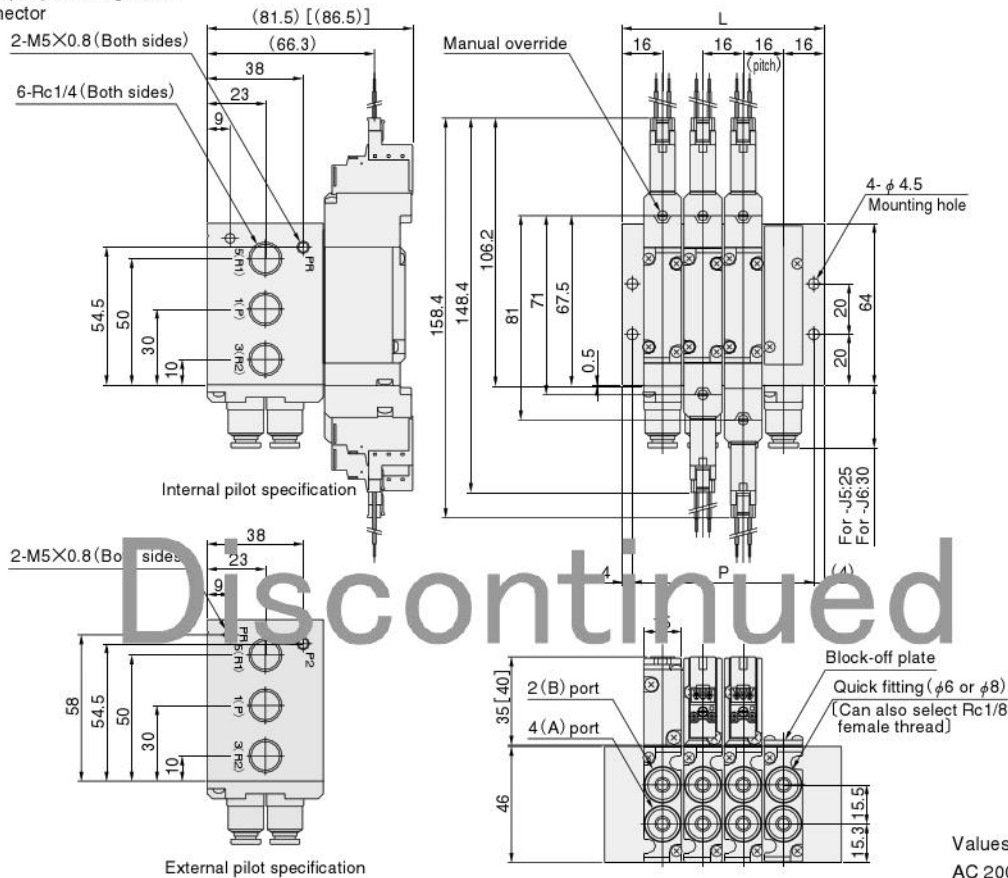

Unit dimensions

Number of units	L	P
2	48	40
3	64	56
4	80	72
5	96	88
6	112	104
7	128	120
8	144	136
9	160	152
10	176	168
11	192	184
12	208	200
13	224	216
14	240	232
15	256	248
16	272	264
17	288	280
18	304	296
19	320	312
20	336	328

Values in brackets [] are for AC 200V specification.

GF15M Number of units **F** (direct piping type)



Monoblock manifold F type
With valve output port fitting block
S type plug connector

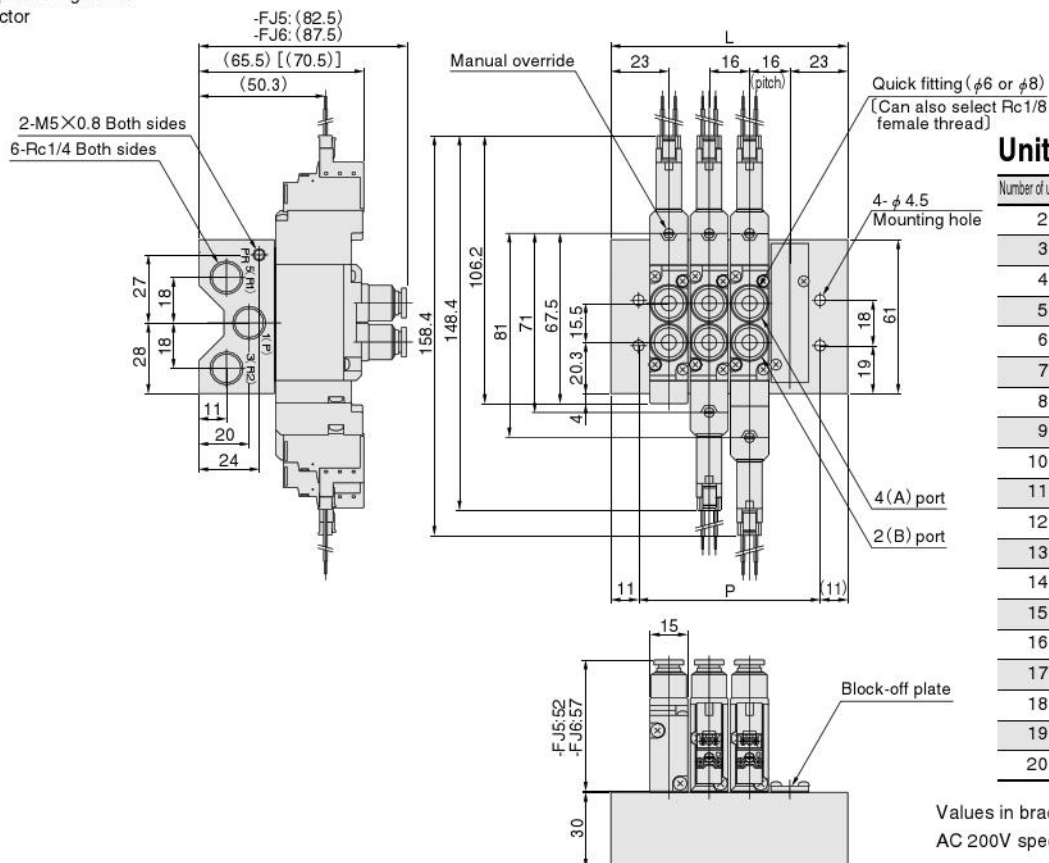

Unit dimensions

Number of units	L	P
2	62	40
3	78	56
4	94	72
5	110	88
6	126	104
7	142	120
8	158	136
9	174	152
10	190	168
11	206	184
12	222	200
13	238	216
14	254	232
15	270	248
16	286	264
17	302	280
18	318	296
19	334	312
20	350	328

Values in brackets [] are for AC 200V specification.

GF15 Series Dimensions of Monoblock Compact Manifold A type and F type (Scale 1/3, Unit mm)

GF15M Number of units AC $\overset{J}{M}$

Monoblock compact manifold A type
With manifold output port fitting
S type plug connector

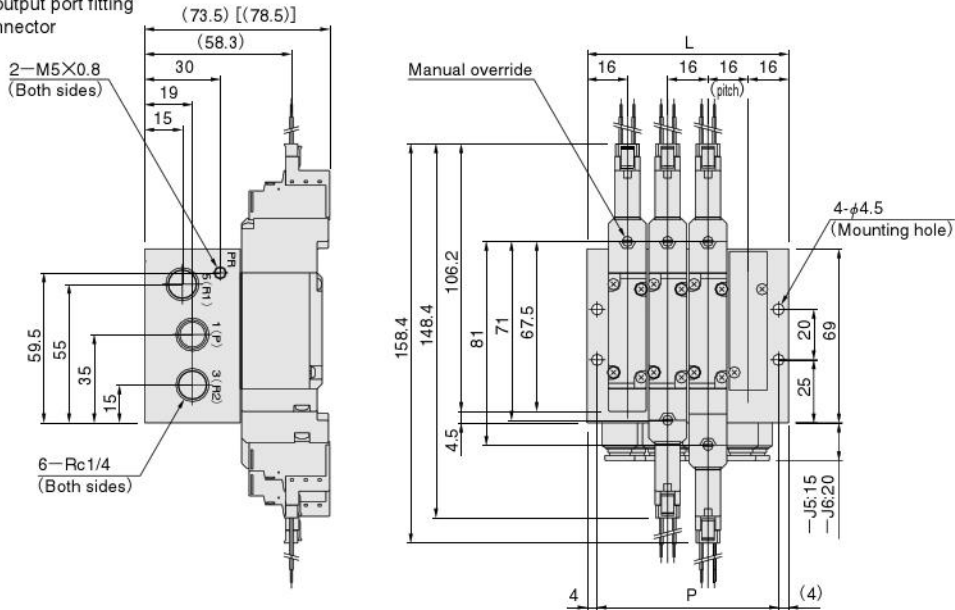

Unit dimensions

Number of units	L	P
2	48	40
3	64	56
4	80	72
5	96	88
6	112	104
7	128	120
8	144	136
9	160	152
10	176	167
11	192	184
12	208	200
13	224	216
14	240	232
15	256	248
16	272	264
17	288	280
18	304	296
19	320	312
20	336	328

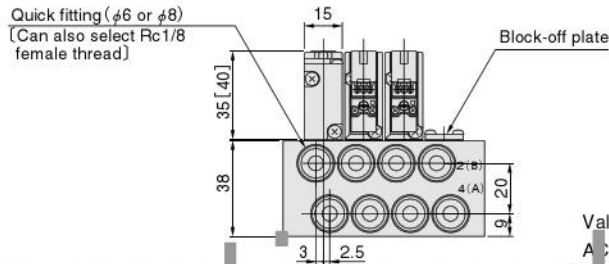

Values in brackets [] are for AC 200V specification.

GF15M Number of units FC

Monoblock compact manifold F type
With valve output port fitting block
S type plug connector

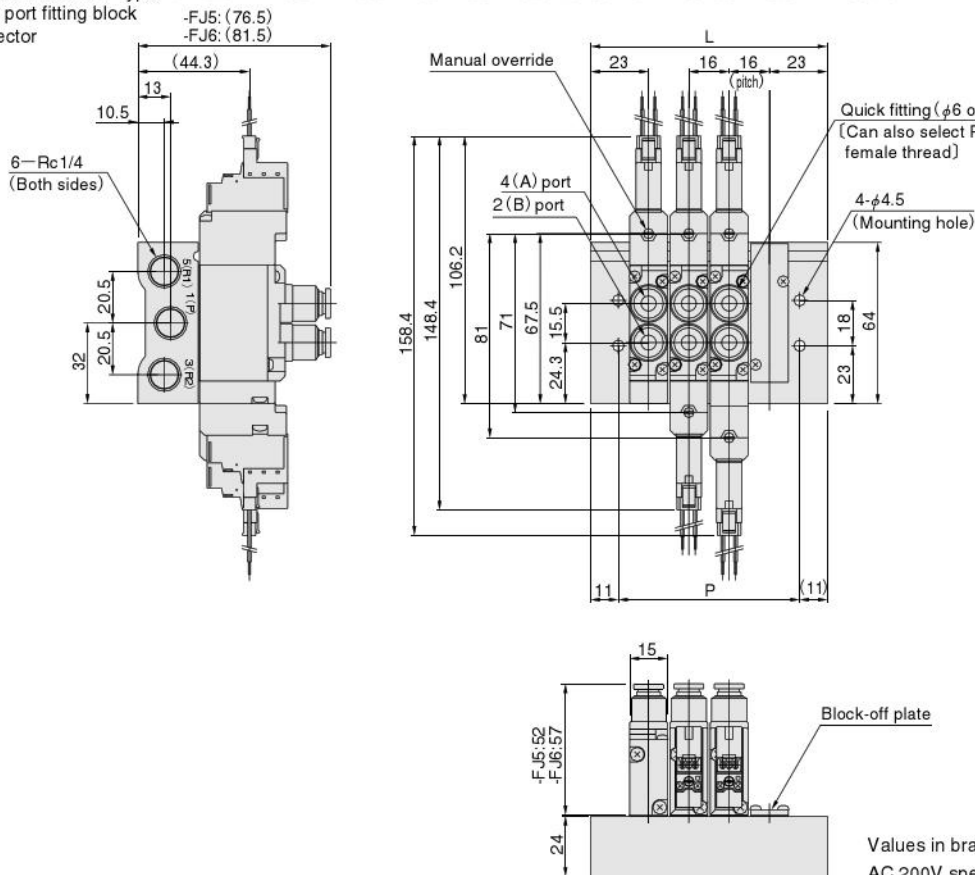

Unit dimensions

Number of units	L	P
2	62	40
3	78	56
4	94	72
5	110	88
6	126	104
7	142	120
8	158	136
9	174	152
10	190	168
11	206	184
12	222	200
13	238	216
14	254	232
15	270	248
16	286	264
17	302	280
18	318	296
19	334	312
20	350	328

Values in brackets [] are for AC 200V specification.

GF15 Series Dimensions of Split Manifold, Non-Plug-in Type

(Scale 1/3, Unit mm)

GF15M Number of units **N** Pilot specification **M** (base piping type)



With manifold output port fitting block
S type plug connector

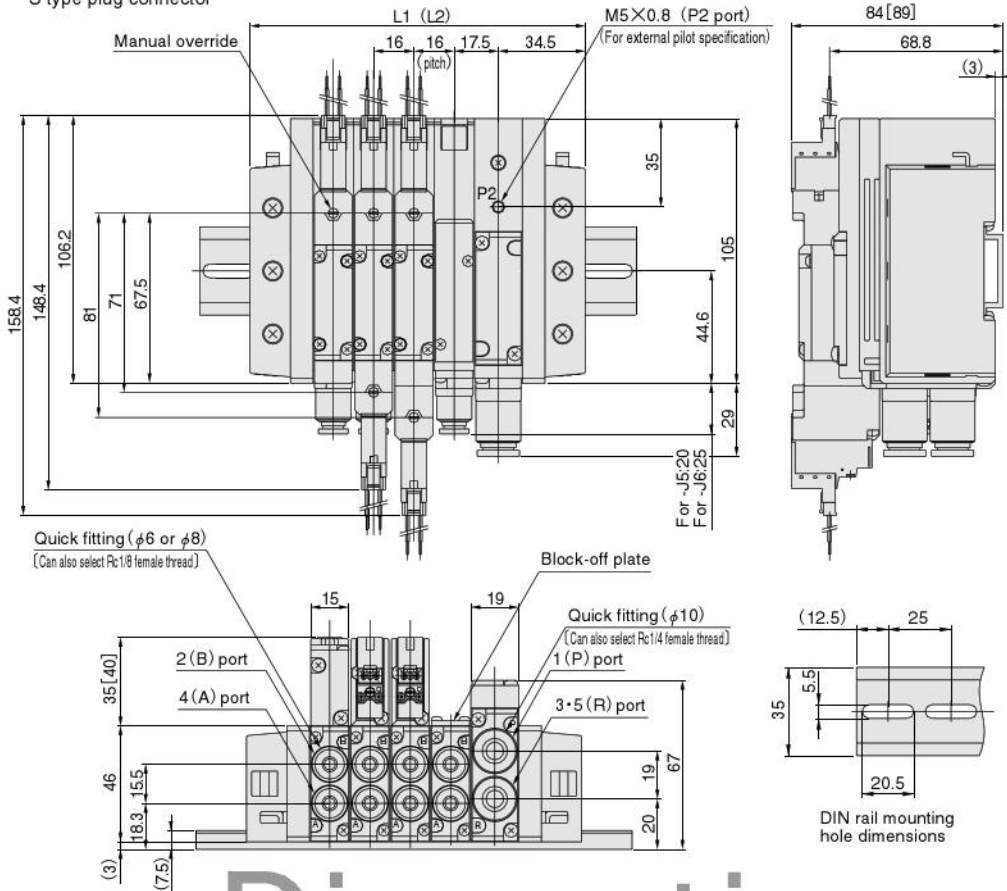

Unit dimensions

Number of units	L1	DIN rail length	L2 <small>Note</small>	DIN rail length <small>Note</small>
2	101	150	120	150
3	117	150	136	175
4	133	175	152	200
5	149	175	168	200
6	165	200	184	225
7	181	225	200	250
8	197	225	216	250
9	213	250	232	275
10	229	275	248	275
11	245	275	264	300
12	261	300	280	325
13	277	325	296	325
14	293	325	312	350
15	309	350	328	375
16	325	375	344	375
17	341	375	360	400
18	357	400	376	425
19	373	400	392	425
20	389	425	408	450

Note: When using two piping blocks.

Values in brackets [] are for AC 200V specification.

GF15M Number of unit **N** Pilot specification **M** (direct piping type)



With valve output port fitting block
S type plug connector

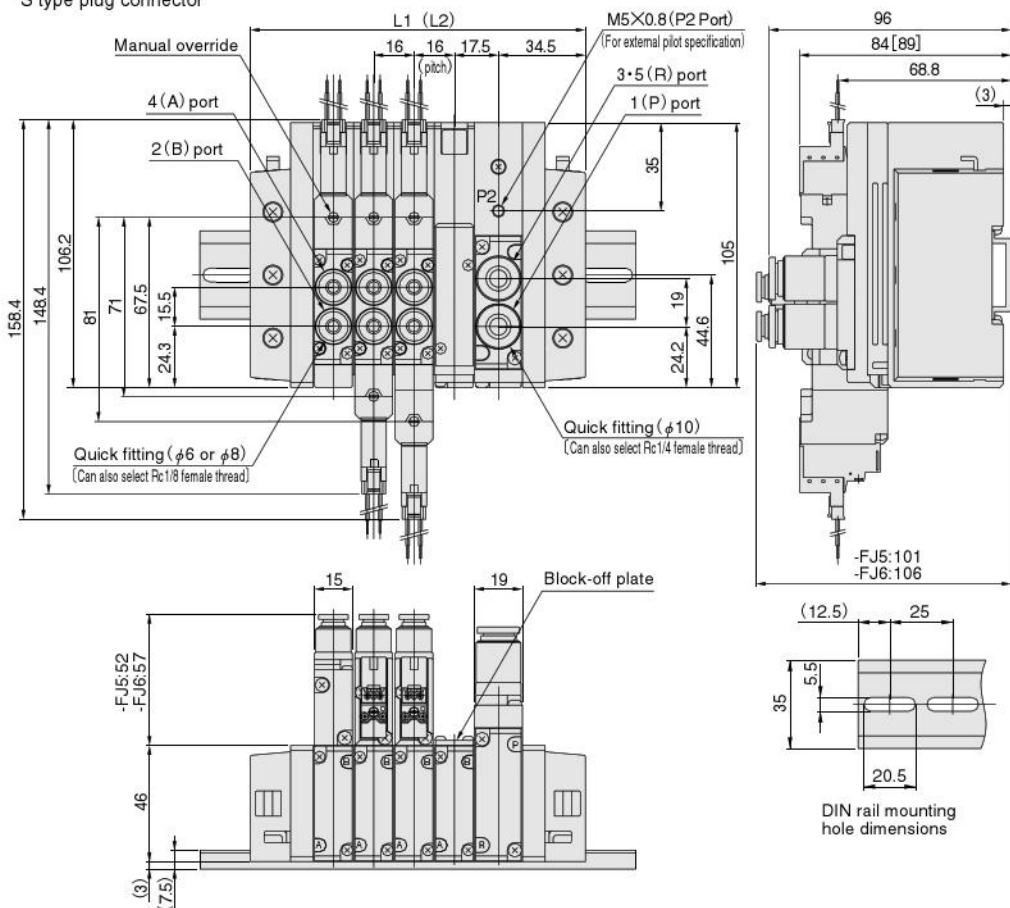

Unit dimensions

Number of units	L1	DIN rail length	L2 <small>Note</small>	DIN rail length <small>Note</small>
2	101	150	120	150
3	117	150	136	175
4	133	175	152	200
5	149	175	168	200
6	165	200	184	225
7	181	225	200	250
8	197	225	216	250
9	213	250	232	275
10	229	275	248	275
11	245	275	264	300
12	261	300	280	325
13	277	325	296	325
14	293	325	312	350
15	309	350	328	375
16	325	375	344	375
17	341	375	360	400
18	357	400	376	425
19	373	400	392	425
20	389	425	408	450

Note: When using two piping blocks.

Values in brackets [] are for AC 200V specification.

Female Thread Specification (Scale 1/3, Unit mm)

● Split manifold non-plug-in type

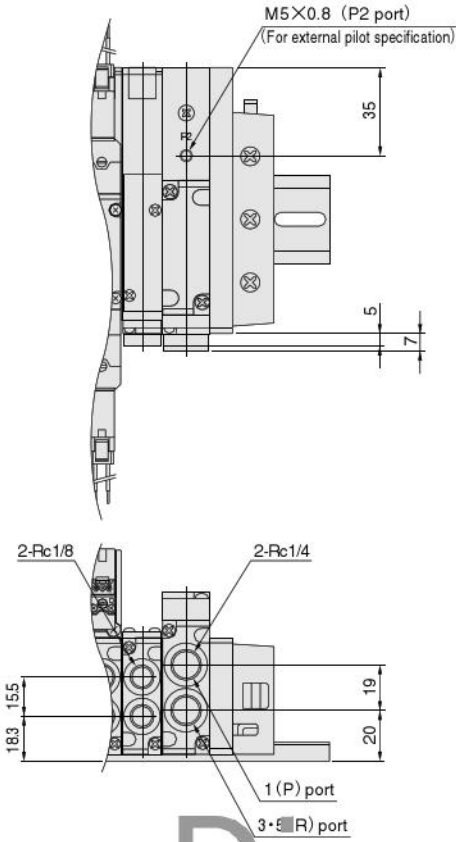

● Monoblock compact manifold A type

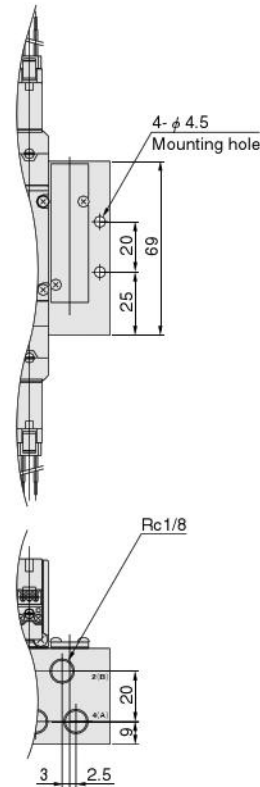

Discontinued

Additional Parts (Sold Separately)

● Muffler: **KM-J10**

(Scale 2/3, Unit mm)

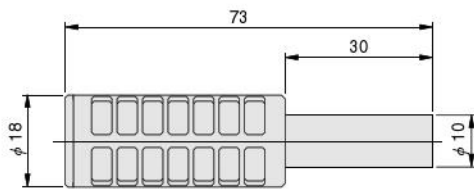

● Muffler: **KM-J6** [For individual air supply and exhaust spacer only]

(Scale 2/3, Unit mm)

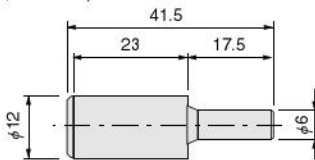

● Muffler: **KM-J8** [For individual air supply and exhaust spacer only]

(Scale 2/3, Unit mm)

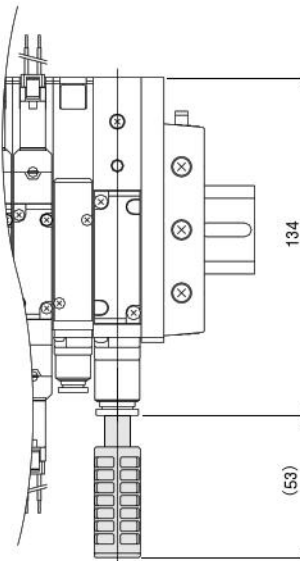
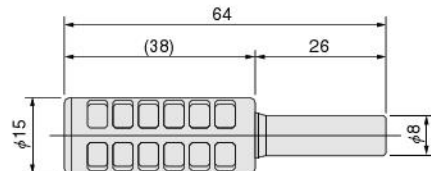

SOLENOID VALVES GF18 SERIES

INDEX

Specifications	486
Dimensions of Single Valve Unit	489
Dimensions of Monoblock Manifold	493
Dimensions of Split Non-Plug-in Type	494



Discontinued

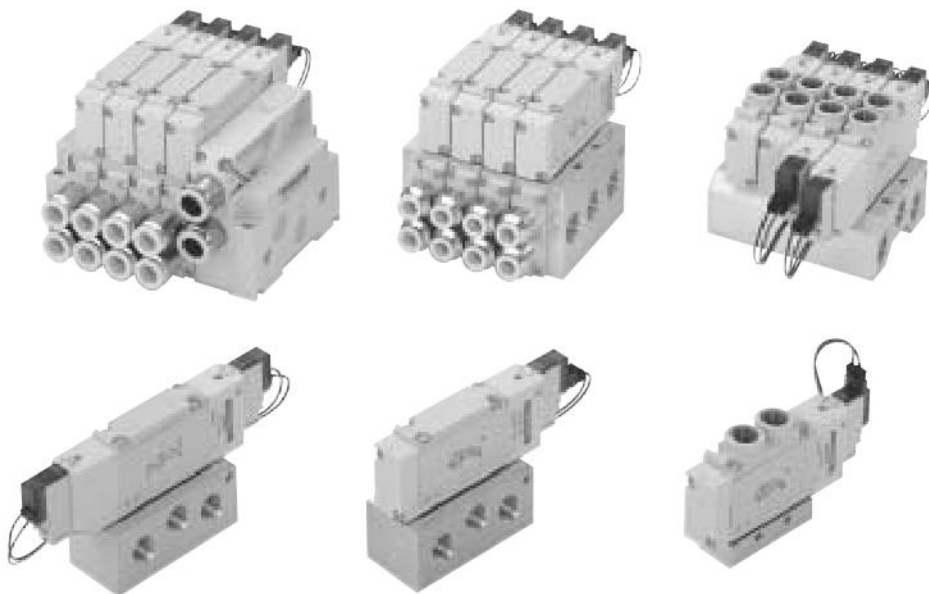

GF18 SERIES SPECIFICATIONS

Specifications

Basic Models and Valve Functions

Item \ Basic model	GF18T1 GF18T2	GF18T3 GF18T4 GF18T5
Number of positions	2 positions	3 positions
Number of ports	5	
Valve function	Single solenoid or double solenoid	All port block, ABR connection or PAB connection

Remarks: For optional specifications and order code, see p. 448~459.

Specifications

Item \ Basic model	GF18T1 GF18T2	GF18T3 GF18T4 GF18T5	GF18T1G GF18T2G	GF18T3G GF18T4G GF18T5G	GF18T1V GF18T2V	GF18T3V
Media	Air					
Operation method	Internal pilot type		External pilot type (for positive pressure)		External pilot type (for vacuum)	
Effective area [Cv] ^{Note 1} mm ²	18 [1]					
Port size ^{Note 2}	φ 8, φ 10 fitting, Rc1/4		M5×0.8, φ 8, φ 10 fitting, Rc1/4			
Lubrication	Not required					
Operating pressure range	Main valve	0.15~0.7MPa {1.5~7.1kgf/cm ² }	0~0.7MPa {0~7.1kgf/cm ² } ^{Note 3}		0.15MPa~100kPa {1.5kgf/cm ² ~750.1mmHg}	
	External pilot	—	0.2~0.7MPa {2~7.1kgf/cm ² } ^{Note 3}		0.2~0.7MPa {2~7.1kgf/cm ² }	
Proof pressure	MPa {kgf/cm ² } 1.05 {10.7}					
Response time ^{Note 4} ms	DC12V, DC24V	30/50, [35]	20/70	30/50, [35]	20/70	30/50, [35]
	AC100V, AC200V	25/40, [30]	20/60	25/40, [30]	20/60	25/40, [30]
Maximum operating frequency	Hz 5					
Minimum time to energize for self holding ^{Note 5}	ms 50					
Operating temperature range (atmosphere and media)	°C 5~50					
Shock resistance	m/s ² [G]	1373 {140.0}	294.2 {30.0}	1373 {140.0}	294.2 {30.0}	1373 {140.0}
		[pilot valve axial direction] 294.2 {30.0}		[pilot valve axial direction] 294.2 {30.0}		[pilot valve axial direction] 294.2 {30.0}
Mounting direction	Any					

Notes: 1. For details, see the effective area on p.487.

2. For details, see the port size on p.487.

3. When the main valve pressure is 0.2~0.7MPa, set the external pilot pressure to the main valve pressure or higher and to 0.7 MPa or less.

4. Values when air pressure is 0.5MPa. Values in brackets [] are for T2. And the values for 3-position valves are those switching from the neutral position. For switching phase timing, add a maximum of 5 ms to the response time of AC specification.

5. For the double solenoid.

Remark: Conversion to psi., 1Mpa=145psi., 1kgf/cm²=14.2psi., e.g. 0.15Mpa=21.8psi.

Solenoid Specifications

Item \ Rated voltage	DC12V	DC24V	AC100V ^{Note}		AC200V ^{Note}	
Operating voltage range	V 10.8~13.2 (12±10%)	21.6~26.4 (24±10%)	90~110 (100±10%)		180~220 (200±10%)	
Rated frequency	Hz —	—	50	60	50	60
Current (When rated voltage is applied)	mA (r.m.s) 42	21	11		8	
Power consumption	0.5W	0.5W	1.1VA		1.6VA	
Allowable leakage current	mA 1.0	1.0	1.0		1.0	
Insulation resistance	MΩ Min. 100 (value at DC500V megger)					
Wiring and lead wire length	Grommet type: 300mm Plug connector type: 300mm, 3000mm					
Color of lead wire	Red (+), Black (-)		Yellow		White	
Color of LED indicator	Red					
Surge suppression (as standard)	Flywheel diode			Bridge diode		

Notes: 1. Since the AC types have built-in bridge diodes, the starting current value and energizing current value are virtually the same.

2. For long time continuous energizing of AC types, consult us.

3. Provide heat radiation measures to ensure that the ambient temperature (or when using a control box, the internal temperature of the box) always remains within the temperature range specifications.

Cylinder Operating Speed

How to obtain cylinder speed

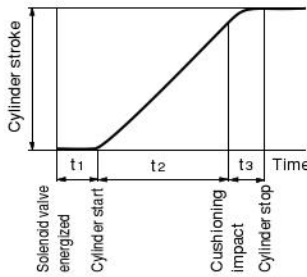

Measurement conditions

- Air pressure: 0.5MPa {5.1kgf/cm²}
- Piping (outer diameter X inner diameter X length): φ10Xφ7.5X1000mm
- Fitting: Quick fitting TS10-02
- Load ratio = $\frac{\text{Load}}{\text{Cylinder theoretical thrust}}$ (%)
- Cylinder stroke: 150mm

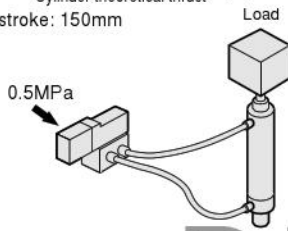

Maximum operating speed

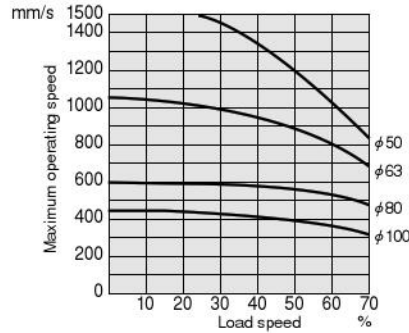

Delay time

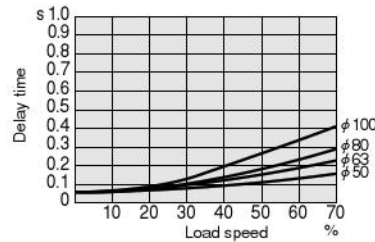

Note: Delay time may vary according to the cylinder stroke.

Flow Rate

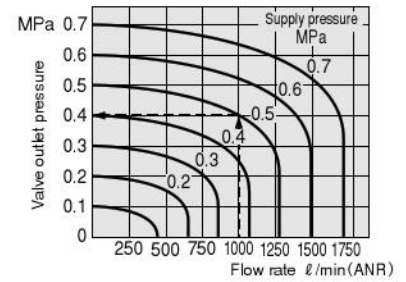

How to read the graph

If supply pressure is 0.5MPa and flow rate is 1000 l/min (ANR), the valve outlet pressure becomes 0.4MPa.

Port Size

Discontinued

● GF18 series

Item/Piping specification		PR	P2	A, B	P, R
Single unit	With sub-base	M5×0.8	M5×0.8	Rc 1/4	Rc 1/4
	With female thread block	—	—	Rc 1/4	Rc 1/4
	With fitting block	—	—	φ 8, φ 10	Rc 1/4
Manifold	Monoblock type with female thread block	M5×0.8	M5×0.8	Rc 1/4	Rc 3/8
	Monoblock type with fitting block	M5×0.8	M5×0.8	φ 8, φ 10	Rc 3/8
	Split type with female thread block	—	M5×0.8	Rc 1/4	Rc 3/8
	Split type with fitting block	—	M5×0.8	φ 8, φ 10	φ 12

Effective Area [Cv]

● When using as a single unit

Basic model	Effective Area [Cv]	mm ²
GF18T1□-A2 GF18T2□-A2 GF18T3□-A2 GF18T4□-A2 GF18T5□-A2	17.3 [0.96]	
GF18T1□-F4 GF18T2□-F4 GF18T3□-F4 GF18T4□-F4 GF18T5□-F4	17.3 [0.96]	
GF18T1□-F5 GF18T2□-F5 GF18T3□-F5 GF18T4□-F5 GF18T5□-F5	15.0 [0.83]	
GF18T1□-F6 GF18T2□-F6 GF18T3□-F6 GF18T4□-F6 GF18T5□-F6	16.5 [0.91]	

● When mounted on the manifold

		Manifold model			mm ²
Valve model		GF18M□F	GF18M□A	GF18M□N	
GF18T1□ GF18T2□ GF18T3□ GF18T4□ GF18T5□	Output port Female thread	17.0 [0.94]	16.0 [0.89]	18.0 [1]	
	Output port φ 8 fitting	15.0 [0.83]	14.7 [0.82]	16.7 [0.93]	
	Output port φ 10 fitting	16.5 [0.91]	15.0 [0.83]	17.0 [0.94]	

Mass

Single Valve Unit

g

Model	GF18T□□	GF18T□□-A1	GF18T□□-A2	GF18T□□-FJ5	GF18T□□-FJ6	GF18T□□-FM	GF18T□□-F4	GF18T□□-F5	GF18T□□-F6
	Output section None	Output section With plate	Output section With plate	Output section With φ 8 fitting block	Output section With φ 10 fitting block	Output section With female thread block	Output section With female thread block	Output section With φ 8 fitting block	Output section With φ 10 fitting block
	Input section None	Input section None	Input section With A type sub-base	Input section None	Input section None	Input section None	Input section With female thread block	Input section With female thread block	Input section With female thread block
T1	100	126	291	171	181	133	158	196	206
T2	120	147	312	192	202	154	178	217	226
T3, T4, T5	129	156	321	201	210	162	187	226	235

Block-off plate: 32g

Monoblock Manifold Mass

g

Monoblock manifold	Mass calculation of each unit (n=number of units)			Additional mass
Monoblock manifold A type	Manifold A, B port output specification			128
	With female thread block	-J5 with φ 8 fitting block	-J6 with φ 10 fitting block	
	(225×n)	(263×n)	(273×n)	
Monoblock manifold F type	(86×n)			124

Calculation example: **GF18M8AJ**

stn.1~stn.8 GF18T1-A1-PS-J5 DC24V

$(263 \times 8) + 128 + (126 \times 8) = 3240\text{g}$

Discontinued

Split Type Manifold Mass

g

Split type manifold	Mass calculation of each unit (n=number of units)			Additional mass		
Base piping type	Manifold A, B port output specification			Piping block		End block
	With female thread block	-J5 with φ 8 fitting block	-J6 with φ 10 fitting block	With female thread	With fitting block	116
	(148×n)	(187×n)	(197×n)	164	156	
Direct piping type	(142×n)			164	156	116

Calculation example: **GF18M8NJ-JR**

stn.1~stn.8 GF18T1-A1-PS-J5 DC24V

$(187 \times 8) + 156 + 116 + (126 \times 8) = 2776\text{g}$

GF18 Series Dimensions of Single Valve Unit (Scale 1/3, Unit mm)

GF18T1-F5-PS

With output port fitting block
With input port female thread block
S type plug connector

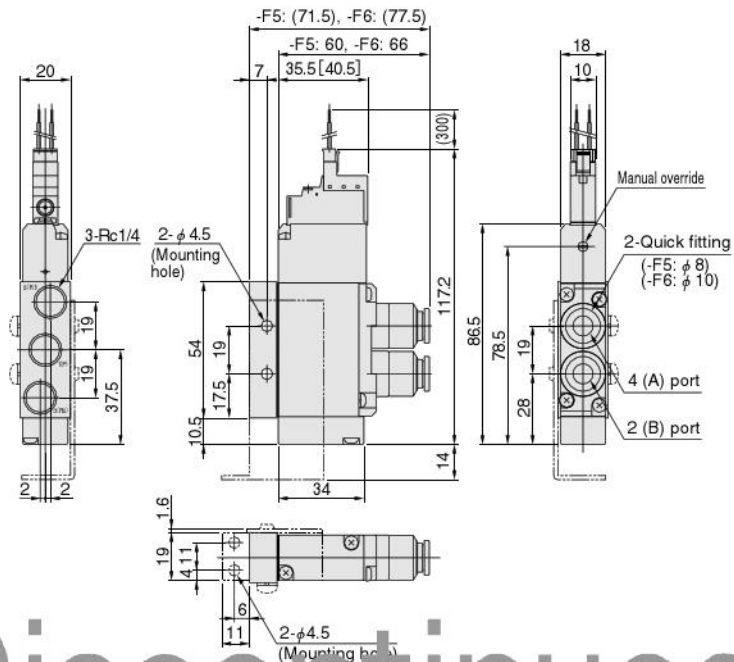

CAD GF18T1F5

Values in brackets [] are for AC 200V specification.

Discontinued

GF18T2-F5-PS

With output port fitting block
With input port female thread block
S type plug connector

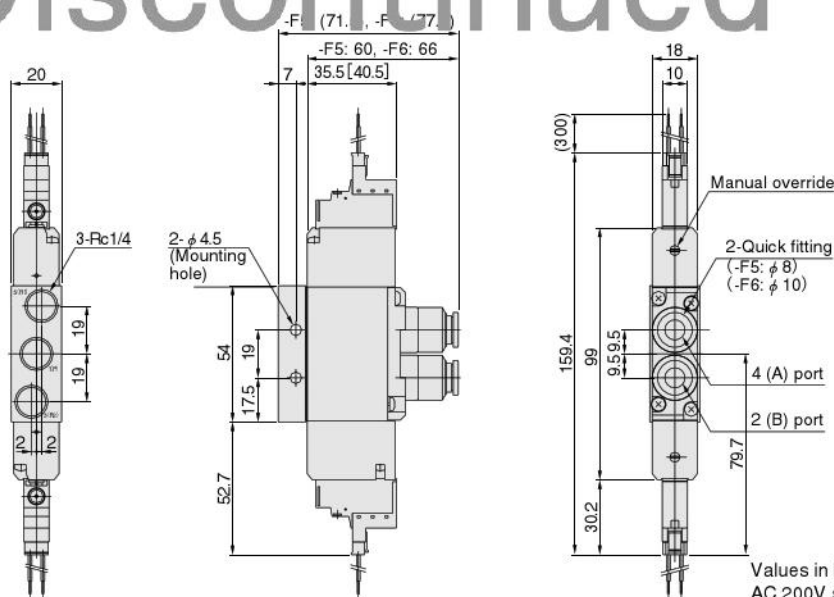

CAD GF18T2F5

Values in brackets [] are for AC 200V specification.

GF18T3-F5-PS GF18T4-F5-PS GF18T5-F5-PS

With output port fitting block
With input port female thread block
S type plug connector

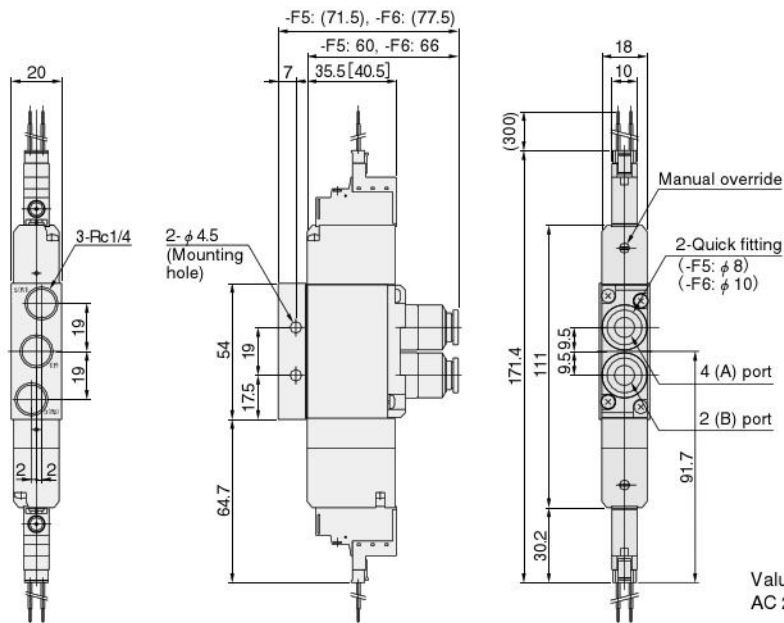

CAD GF18T3F5

Values in brackets [] are for AC 200V specification.

GF18 Series Dimensions of Single Valve Unit (Scale 1/3, Unit mm)

GF18T1-F4-PS

With output port female thread block
With input port female thread block
S type plug connector

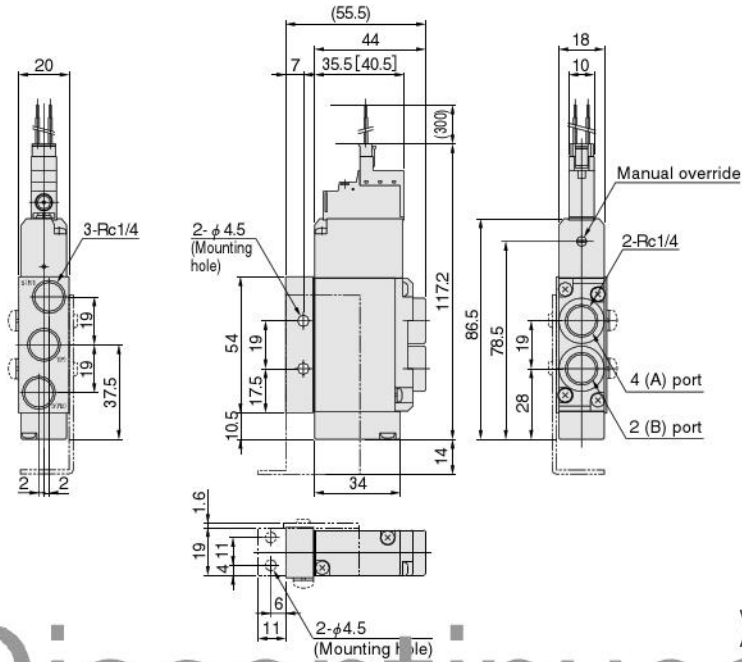

Values in brackets [] are for AC 00V specification.

GF18T2-F4-PS

With output port female thread block
With input port female thread block
S type plug connector

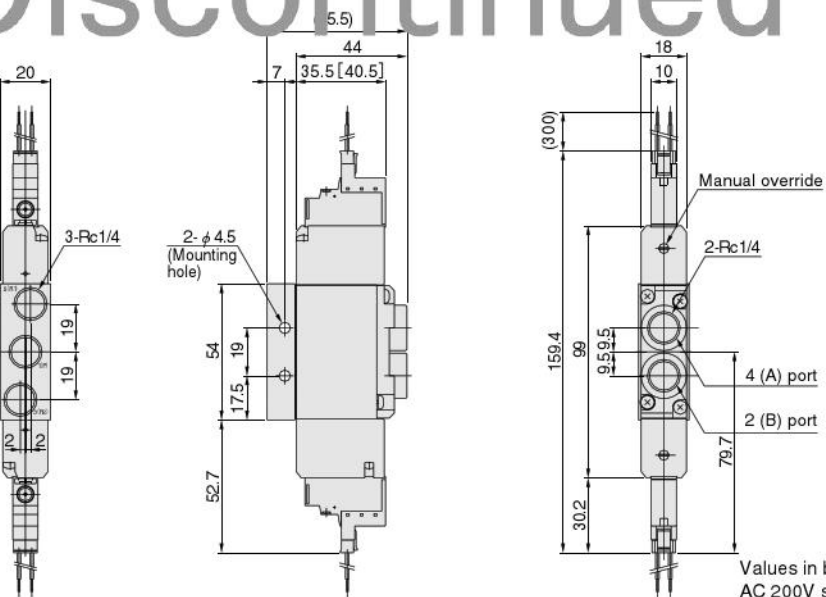
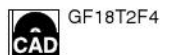

Values in brackets [] are for AC 200V specification.

GF18T3-F4-PS

GF18T4-F4-PS

GF18T5-F4-PS

With output port female thread block
With input port female thread block
S type plug connector

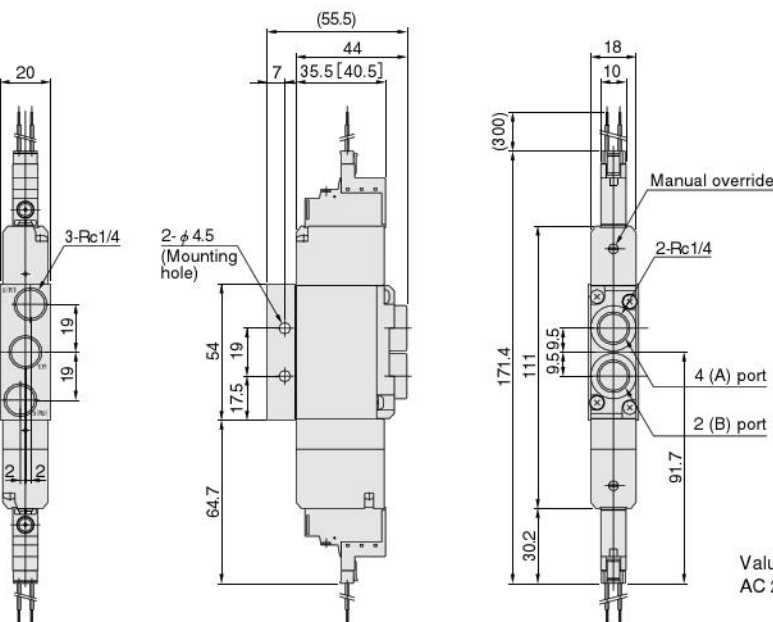

Values in brackets [] are for AC 200V specification.

GF18 Series Dimensions of Single Valve Unit (Scale 1/3, Unit mm)

GF18T1-A2-PS

With A type sub-base
S type plug connector

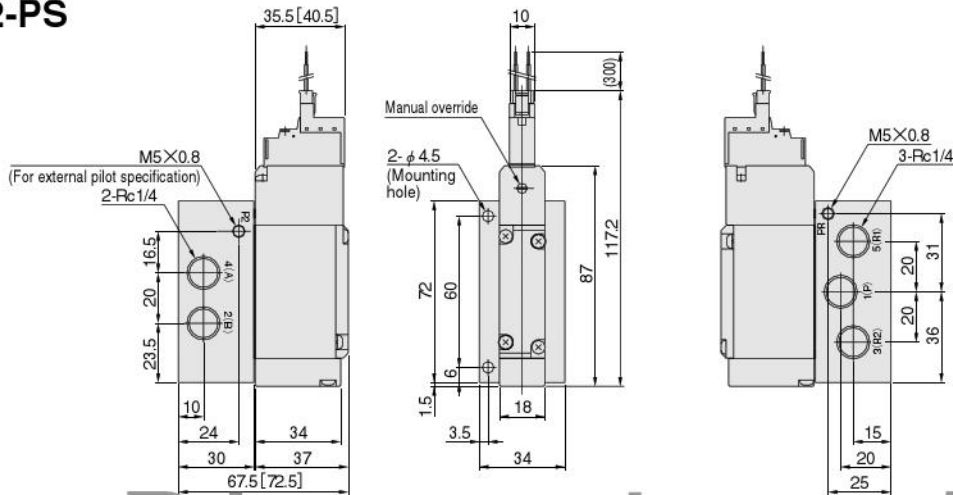

CAD GF18T1A2

Discontinued

Values in brackets [] are for AC 200V specification.

GF18T2-A2-PS

With A type sub-base
S type plug connector

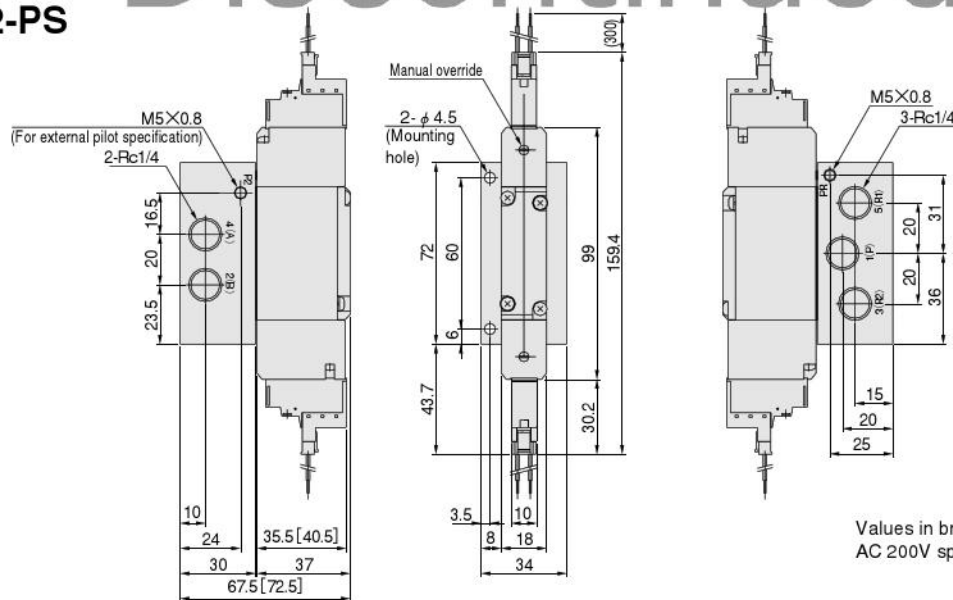

CAD GF18T2A2

Values in brackets [] are for AC 200V specification.

GF18T3-A2-PS GF18T4-A2-PS GF18T5-A2-PS

With A type sub-base
S type plug connector

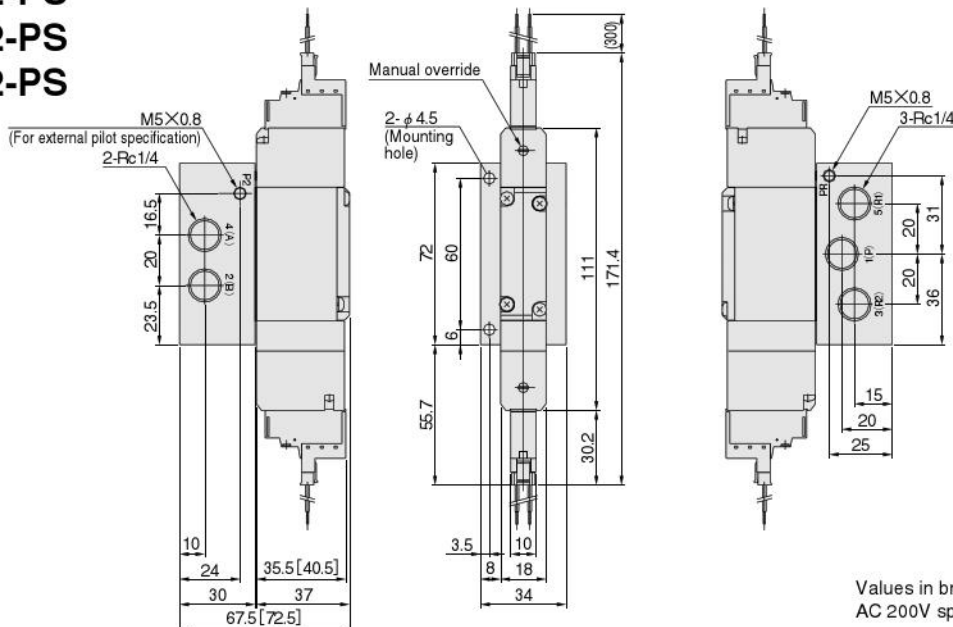

CAD GF18T3A2

Values in brackets [] are for AC 200V specification.

Wiring



●When mounting DC12V, DC24V, AC100V

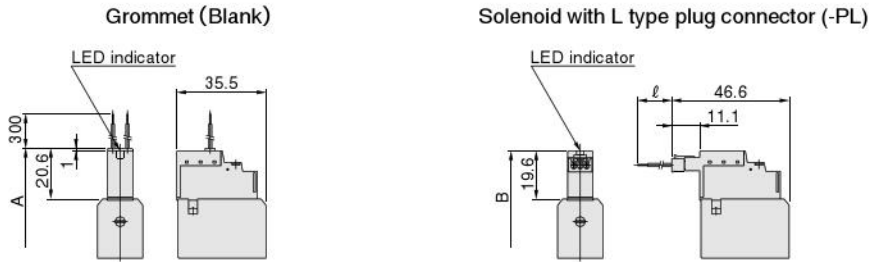

Discontinued

●When mounting AC200V

Grommet (Blank) Solenoid with L type plug connector (-PL) Solenoid with S type plug connector (-PS)

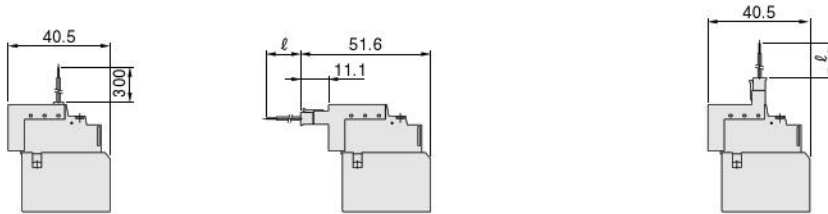

Code	A	B	ℓ (lead wire length)	Remarks
Model				
GF18T1	107.6	106.6	Standard: 300 -P□3: 3000	Length to the end of the valve
GF18T2	140.2	138.2		Total length to the end of the opposite solenoid
GF18T3, 4, 5	152.2	150.2		

GF18 Series Dimensions of Monoblock Manifold A Type and F Type (Scale 1/3, Unit mm)

GF18M Number of units **A^J** Pilot specification (base piping type)



Monoblock manifold A type
With manifold output port fitting block
S type plug connector

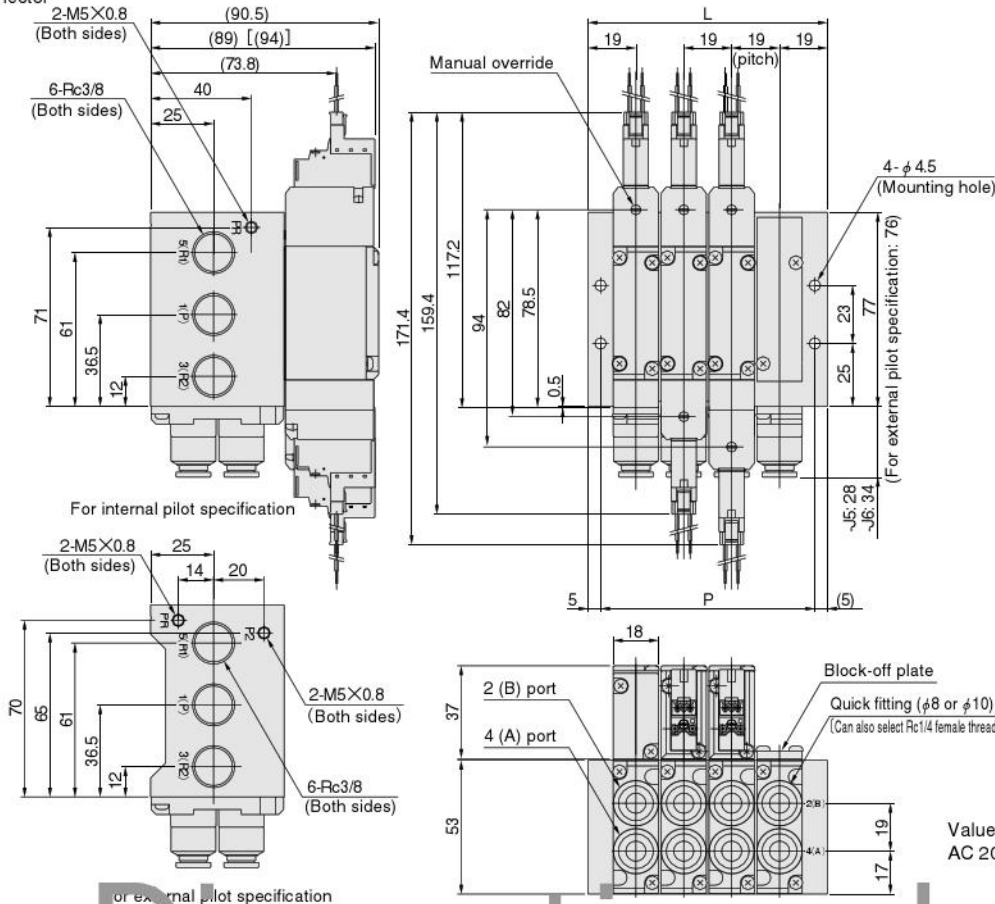

Unit dimensions

Number of units	L	P
2	57	47
3	76	66
4	95	85
5	114	104
6	133	123
7	152	142
8	171	161
9	190	180
10	209	199
11	228	218
12	247	237
13	266	256
14	285	275
15	304	294
16	323	313
17	342	332
18	361	351
19	380	370
20	399	389

Values in brackets [] are for AC 200V specification.

GF18M Number of units **F** (base piping type)



Monoblock manifold F type
With valve output port fitting block
S type plug connector

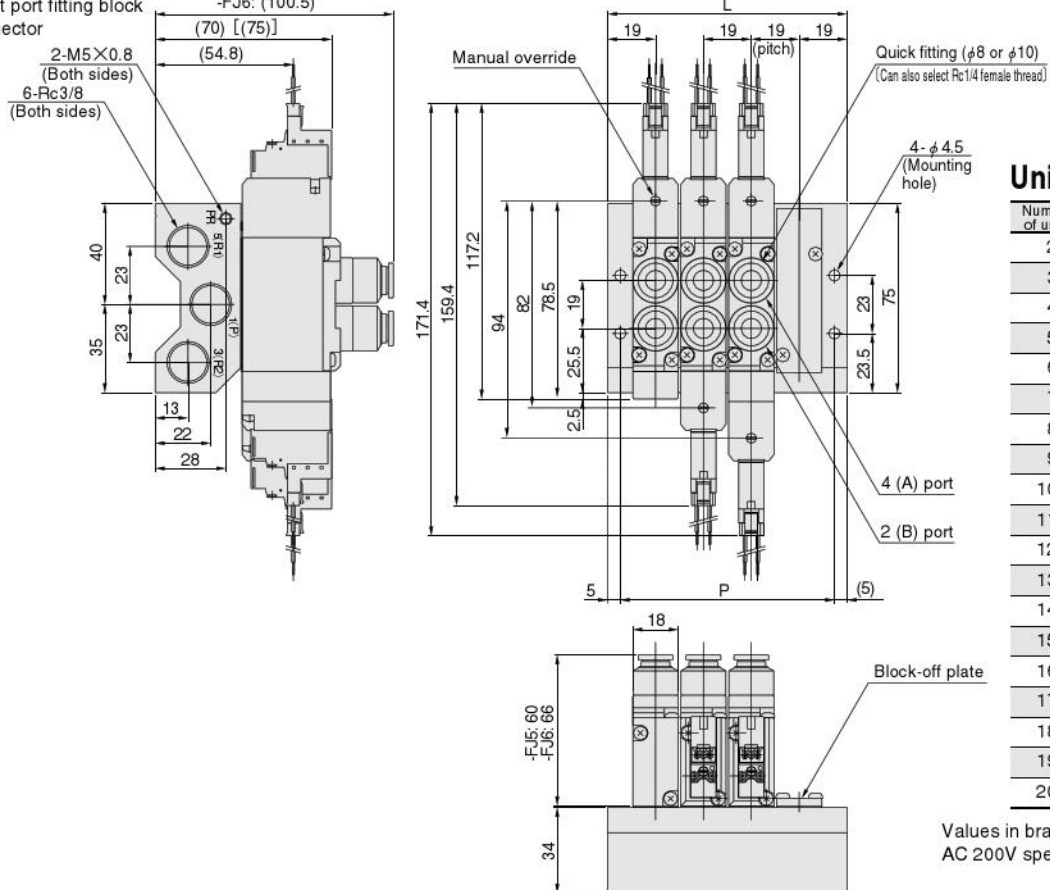

Unit dimensions

Number of units	L	P
2	57	47
3	76	66
4	95	85
5	114	104
6	133	123
7	152	142
8	171	161
9	190	180
10	209	199
11	228	218
12	247	237
13	266	256
14	285	275
15	304	294
16	323	313
17	342	332
18	361	351
19	380	370
20	399	389

Values in brackets [] are for AC 200V specification.

Discontinued

GF18 Series Dimensions of Split Manifold, Non-Plug-in Type (Scale 1/3, Unit mm)

GF18M Number of units N M Pilot specification (base piping type)



With manifold output port fitting block
S type plug connector

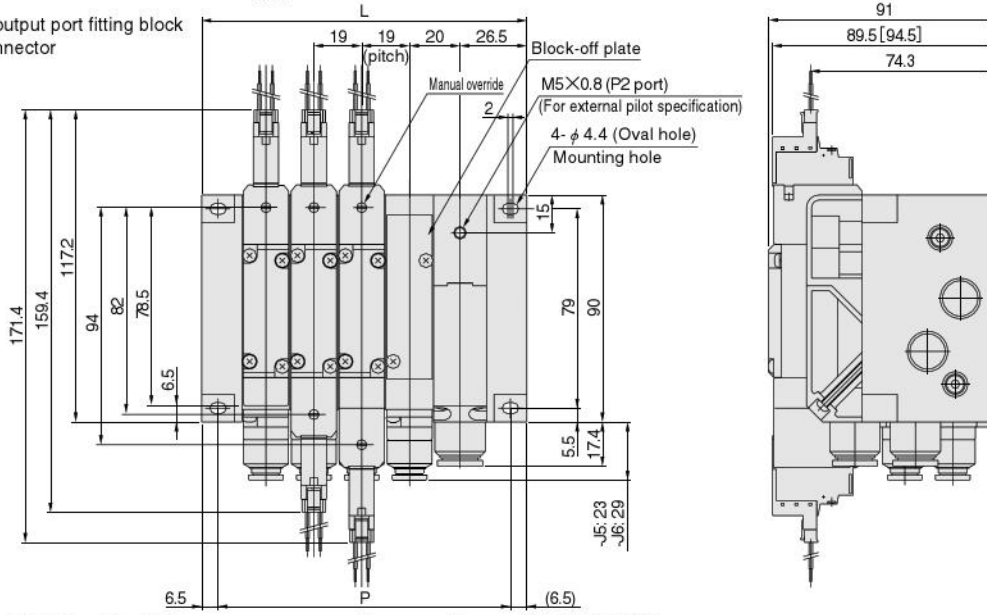

Unit dimensions

Number of units	L	P
2	91	78
3	110	97
4	129	116
5	148	135
6	167	154
7	186	173
8	205	192
9	224	211
10	243	230
11	262	249
12	281	268
13	300	287
14	319	306
15	348	325
16	357	344
17	376	363
18	395	382
19	414	401
20	433	420

Remark: When using two piping blocks, add 21 to the above L and P dimensions.

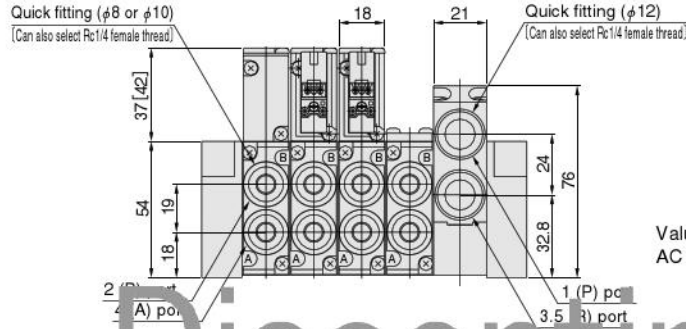

Values in brackets [] are for AC 200V specification.

GF18M Number of units N Pilot specification (direct piping type)



With valve output port fitting block
S type plug connector

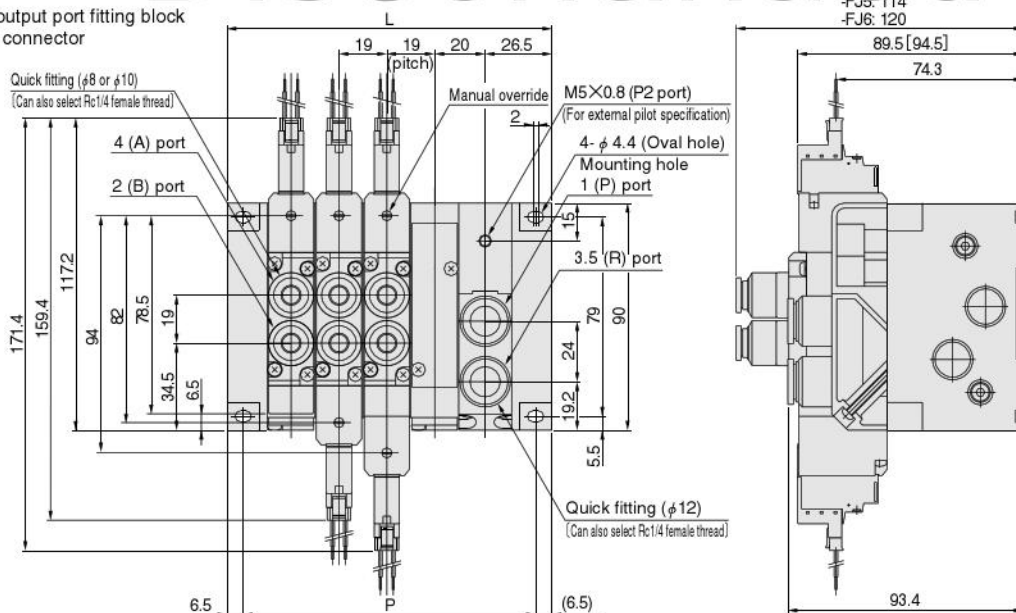

Unit dimensions

Number of units	L	P
2	91	78
3	110	97
4	129	116
5	148	135
6	167	154
7	186	173
8	205	192
9	224	211
10	243	230
11	262	249
12	281	268
13	300	287
14	319	306
15	348	325
16	357	344
17	376	363
18	395	382
19	414	401
20	433	420

Remark: When using two piping blocks, add 21 to the above L and P dimensions.

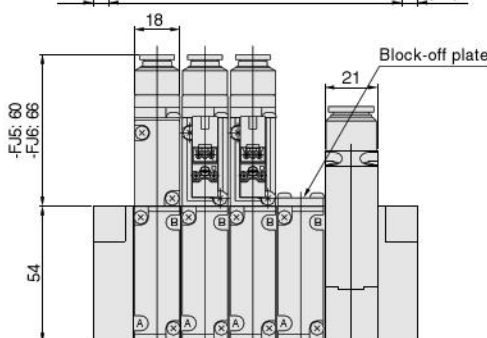

Values in brackets [] are for AC 200V specification.

Female Thread Specification (Scale 1/4, Unit mm)

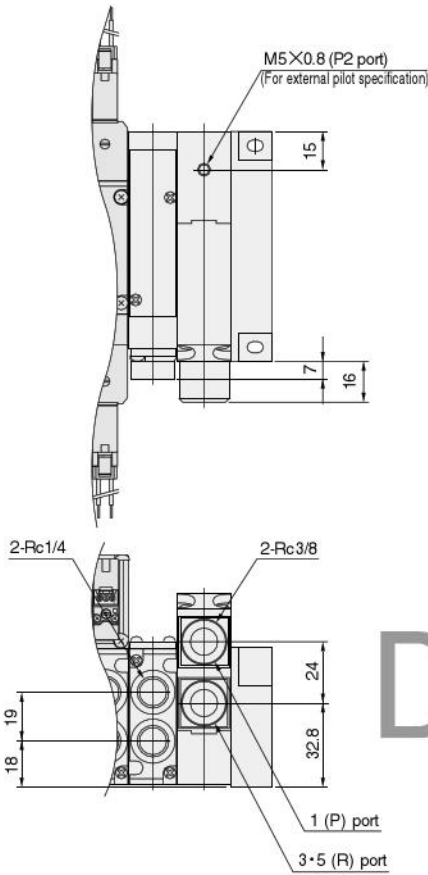

Discontinued

Additional Parts (Sold Separately)

● Muffler: **KM-J12**

(Scale 2/3, Unit mm)

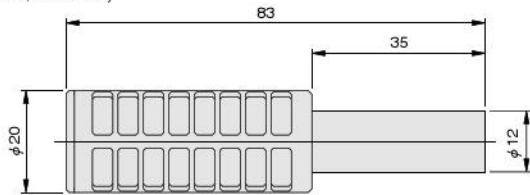

● Muffler: **KM-J8** [For individual air supply and exhaust spacer only]

(Scale 2/3, Unit mm)

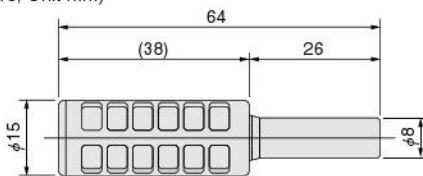

● Muffler: **KM-J10** [For individual air supply and exhaust spacer only]

(Scale 2/3, Unit mm)

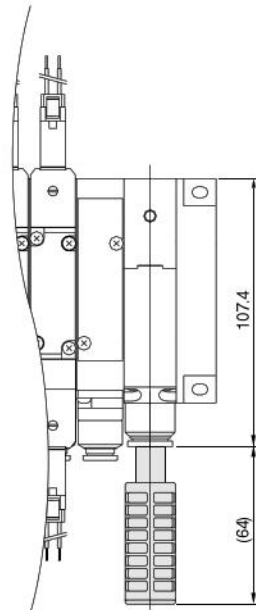
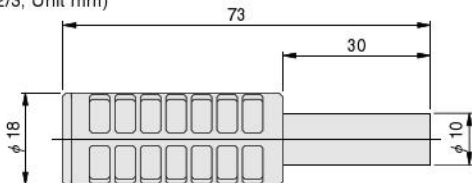

GF SERIES SPECIFICATIONS CONFIRMATION FORM

INDEX

Example of Specifications Confirmation Form	498
Monoblock Manifold A type	499
Monoblock Compact Manifold A type	500
Monoblock Manifold F type	501
Monoblock Compact Manifold F type	502
Split Non-Plug-in Type	503



Example of Specifications Confirmation Form

Example

When ordering GF series manifolds, use this specifications confirmation form for complicated model configurations, for confirming specifications, etc. Using the example below for reference, fill out the required items in the "Specifications Confirmation Forms" found on p. 499 and up, and send it to us. (Make A4 size copies of the Specifications Confirmation Form for your use.)

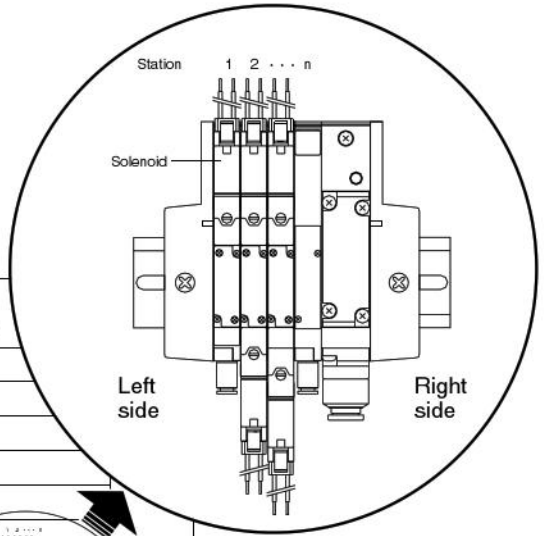

Solenoid Valves GF Series Split manifold non-plug-in type Specifications Confirmation Form

● Fill in selections inside the thick-lined boxes.

Order date Month/ Date/

Company name _____
Name of the person in charge _____
Order number _____
Equipment name _____

Illustration shows the GF10 series.

Manifold model: **GF10M8NJ-JR**

Valve size: 10: 10mm width, 15: 15mm width, 18: 18mm width

Number of units: 2~20

Pilot specification: Blank: Internal pilot manifold, G: External pilot manifold

Manifold output specification: J: With fitting block, M: With female thread block, Blank: With plate (direct piping type)

Piping block specification: JR: With fitting on right side, JL: With fitting on left side, JD: With fittings on both sides, MR: With female thread on right side, MD: With female threads on both sides, ML: With female thread on left side

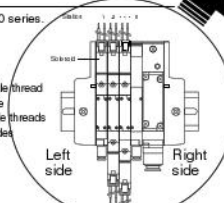

Manifolding valve type: **strn. GF Valve size T Valve specification**

Manual override: Blank: Locking type manual override, 80: Non-locking type manual override

Operation method: Blank: Internal pilot type, G: External pilot type

Wiring: Blank: Grommet type, lead wire 300mm, PS: S type plug connector, lead wire 3000mm, PL: L type plug connector, lead wire 3000mm

Split: Blank: Without split, SP: For P port, SR: For R port, SA: For both P and R ports

Individual air supply and exhaust spacer: Blank: Without spacer, NPM: Individual air supply spacer (with M5 female thread for GF10), NPF: Individual air supply spacer (with #6 fitting for GF15), NPS: Individual air supply spacer (with #8 fitting for GF15 and GF18), NPO: Individual air supply spacer (with #10 fitting for GF18), NRM: Individual exhaust spacer (with M5 female thread for GF10), NRE: Individual exhaust spacer (with #6 fitting for GF15), NRS: Individual exhaust spacer (with #8 fitting for GF15 and GF18), NRO: Individual exhaust spacer (with #10 fitting for GF18)

Manifold fitting specification: J5: Can be selected with manifold output specification J (with fitting block), manifold output port fitting GF10: #4, GF15: #6, GF18: #8, J6: Can be selected with manifold output specification J (with fitting block), manifold output port fitting GF10: #6, GF15: #8, GF18: #10

Valve type: A1: With plate (When manifold output specifications are J or M, the valve type is A1), FJ5: With fitting block (Can be selected when manifold output specification is "Blank", valve output fittings GF10: #4, GF15: #6, GF18: #8), FJ6: With fitting block (Can be selected when manifold output specification is "Blank", valve output fittings GF10: #6, GF15: #8, GF18: #10), FM: With female thread block (Can be selected when manifold output specification is "Blank", valve output female thread GF10: M5 x 0.8, GF15: Rc1/8, GF18: Rc1/4)

※ For the valve and block-off plate mounted at each station, enter ○ for each designated station below.

Mounting valve, block-off plate	Station	1	2	3	4	5	6	7	8	9	10	11	12	13	14	15	16	17	18	19	20	Quantity
GF...T1 2-position, single solenoid specification		○	○																			3
GF...T2 2-position, double solenoid specification				○	○																	2
GF...T3 3-position, all port block						○																1
GF...T4 3-position, ABR connection							○															1
GF...T5 3-position, FAB connection								○														1
GF...BPN Block-off plate									○													1
Manual override (-80) Non-locking type manual override		○	○																			2
Valve type	FJ5 With fitting block																					
	FJ6 With fitting block																					
	FM With female thread block																					
Manifold Fitting Specification	J5 Manifold side fitting	○	○	○	○	○																5
	J6 Manifold side fitting						○	○	○													3
Split (-SP) For P port																						
Split (-SR) For R port																						
Split (-SA) For both P and R ports																						
NPM Individual air supply spacer (with M5 female thread for GF10)																						
NPF Individual air supply spacer (with #6 fitting for GF15)																						
NPS Individual air supply spacer (with #8 fitting for GF15 and GF18)																						
NPO Individual air supply spacer (with #10 fitting for GF18)																						
NRM Individual exhaust spacer (with M5 female thread for GF10)																						
NRE Individual exhaust spacer (with #6 fitting for GF15)																						
NRS Individual exhaust spacer (with #8 fitting for GF15 and GF18)																						
NRO Individual exhaust spacer (with #10 fitting for GF18)																						

Notes: 1. Cannot be mounted on the external pilot manifold. 2. Cannot be mounted on the internal pilot manifold. 3. To designate a non-locking type manual override, enter ○ in the manual override column of the designated stations in the above table. 4. When the manifold output specifications are "Blank", select from FJ5, FJ6 or FM in the valve type column of the above table, and enter ○ for each station. 5. When the manifold output specifications are J (with fitting block), select from J5 or J6 in the manifold fitting specification column of the above table, and enter ○ for each station. 6. To designate a split, enter ○ in the split column of the designated stations in the above table. 7. Split can be mounted as long as piping blocks are attached to both sides. In addition, the number of splits that can be mounted on one manifold set is limited to one location (one station). Splits are equipped at time of delivery in the space between the designated station and the station to its left (the side with the smaller station number). 8. When mounting the individual air supply or exhaust spacer, enter ○ in the spacer column of the designated stations in the above table. Note that the spacer cannot be mounted on stations other than with valve specification T1.

Quantity **5** set Delivery date **June 1** 503

Solenoid Valves GF Series

Monoblock manifold A type

Specifications Confirmation Form

● Fill in selections inside the thick-lined boxes.

Company name	
Name of the person in charge	
Order number	
Equipment name	

Manifold model

GF M A

Valve size
 10: 10mm width
 15: 15mm width
 18: 18mm width

Number of units
 2~20

Pilot specification
 Blank : Internal pilot manifold
 G : External pilot manifold

Manifold output specification
 J : With fitting block
 M : With female thread block

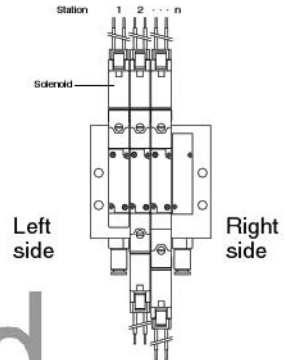

Discontinued

Illustration shows the GF10 series.

stn. GF Valve size T Valve specification - Note 3 - A1 - - Note 4 - Note 6

Manual override
 Blank : Locking type manual override
 80 : Non-locking type manual override^{Note 3}

Operation method
 Blank : Internal pilot type^{Note 1}
 G : External pilot type (for positive pressure)^{Note 2}
 V : External pilot type (for vacuum)^{Note 2}

Wiring
 Blank: Grommet type, lead wire 300mm
 PS: S type plug connector, lead wire 300mm
 PS3: S type plug connector, lead wire 3000mm
 PL: L type plug connector, lead wire 300mm
 PL3: L type plug connector, lead wire 3000mm

Manifold fitting specification^{Note 4}
 J5: Can be selected with manifold output specification J (with fitting block), manifold output port fitting GF10: φ 4, GF15: φ 6, GF18: φ 8
 J6: Can be selected with manifold output specification J (with fitting block), manifold output port fitting GF10: φ 6, GF15: φ 8, GF18: φ 10

Individual air supply and exhaust spacer^{Note 6}
 Blank: Without spacer
 NPM: Individual air supply spacer (with M5 female thread for GF10)
 NP6: Individual air supply spacer (with φ 6 fitting for GF15)
 NP8: Individual air supply spacer (with φ 8 fitting for GF15 and GF18)
 NP0: Individual air supply spacer (with φ 10 fitting for GF18)
 NRM: Individual exhaust spacer (with M5 female thread for GF10)
 NR6: Individual exhaust spacer (with φ 6 fitting for GF15)
 NR8: Individual exhaust spacer (with φ 8 fitting for GF15 and GF18)
 NR0: Individual exhaust spacer (with φ 10 fitting for GF18)

Voltage
 DC24V, DC12V,
 AC100V, AC200V

Mounting valve type

SOLENOID VALVES GF SERIES

※For the valve and block-off plate mounted at each station, enter ○ for each designated station below.

Mounting valve, block-off plate	Station	1	2	3	4	5	6	7	8	9	10	11	12	13	14	15	16	17	18	19	20	Quantities
GF <input type="text"/> T1	2-position, single solenoid specification																					
GF <input type="text"/> T2	2-position, double solenoid specification																					
GF <input type="text"/> T3	3-position, all port block																					
GF <input type="text"/> T4	3-position, ABR connection ^{Note 5}																					
GF <input type="text"/> T5	3-position, PAB connection ^{Note 5}																					
GF <input type="text"/> BP	Block-off plate																					
Manual override (-80)	Non-locking type manual override																					
Manifold Fitting Specification	J5 Manifold side fitting																					
	J6 Manifold side fitting																					
NPM	Individual air supply spacer (with M5 female thread for GF10)																					
NP6	Individual air supply spacer (with φ 6 fitting for GF15)																					
NP8	Individual air supply spacer (with φ 8 fitting for GF15 and GF18)																					
NP0	Individual air supply spacer (with φ 10 fitting for GF18)																					
NRM	Individual exhaust spacer (with M5 female thread for GF10)																					
NR6	Individual exhaust spacer (with φ 6 fitting for GF15)																					
NR8	Individual exhaust spacer (with φ 8 fitting for GF15 and GF18)																					
NR0	Individual exhaust spacer (with φ 10 fitting for GF18)																					

- Notes: 1. Cannot be mounted on the external pilot manifold.
 2. Cannot be mounted on the internal pilot manifold.
 3. To designate a non-locking type manual override, enter ○ in the manual override column of the designated stations in the above table.
 4. When the manifold output specifications are J (with fitting block), select from J5 or J6 in the manifold fitting specification column of the above table, and enter ○ for each station.
 5. Not available with vacuum valve.
 6. When mounting the individual air supply or exhaust spacer, enter ○ in the spacer column of the designated stations in the above table. Note that the spacer cannot be mounted on stations other than with valve specification T1.

Quantity	set	Delivery date
----------	-----	---------------

Solenoid Valves GF Series

Monoblock compact manifold A type

Specifications Confirmation Form

● Fill in selections inside the thick-lined boxes.

Company name	
Name of the person in charge	
Order number	
Equipment name	

Manifold model

GF M AC

Valve size
10: 10mm width
15: 15mm width

Number of units
2~20

Manifold output specification
J: With fitting block
M: With female thread block

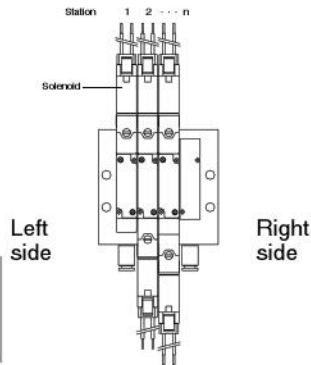

Discontinued

Illustration shows the GF10 series.

Mounting valve type

stn. GF Valve size T Valve specification Note 1 - A1 - - Note 2 - Note 3

Manual override
Blank: Locking type manual override
80: Non-locking type manual override^{Note 1}

Wiring
Blank: Grommet type, lead wire 300mm
PS: S type plug connector, lead wire 300mm
PS3: S type plug connector, lead wire 3000mm
PL: L type plug connector, lead wire 300mm
PL3: L type plug connector, lead wire 3000mm

Manifold fitting specification^{Note 2}
J5: Can be selected with manifold output specification J (with fitting block), manifold output port fitting GF10: φ 4, GF15: φ 6
J6: Can be selected with manifold output specification J (with fitting block), manifold output port fitting GF10: φ 6, GF15: φ 8

Voltage
DC24V
DC12V
AC100V
AC200V

Individual air supply and exhaust spacer^{Note 3}
Blank: Without spacer
NPM: Individual air supply spacer (with M5 female thread for GF10)
NP6: Individual air supply spacer (with φ 6 fitting for GF15)
NP8: Individual air supply spacer (with φ 8 fitting for GF15)
NRM: Individual exhaust spacer (with M5 female thread for GF10)
NR6: Individual exhaust spacer (with φ 6 fitting for GF15)
NR8: Individual exhaust spacer (with φ 8 fitting for GF15)

※For the valve and block-off plate mounted at each station, enter ○ for each designated station below.

Mounting valve, block-off plate	Station	1	2	3	4	5	6	7	8	9	10	11	12	13	14	15	16	17	18	19	20	Quantities	
GF <input type="text"/> T1	2-position, single solenoid specification																						
GF <input type="text"/> T2	2-position, double solenoid specification																						
GF <input type="text"/> T3	3-position, all port block																						
GF <input type="text"/> T4	3-position, ABR connection																						
GF <input type="text"/> T5	3-position, PAB connection																						
GF <input type="text"/> BP	Block-off plate																						
Manual override (-80) Non-locking type manual override																							
Manifold Fitting Specification	J5 Manifold side fitting																						
	J6 Manifold side fitting																						
NPM	Individual air supply spacer (with M5 female thread for GF10)																						
NP6	Individual air supply spacer (with φ 6 fitting for GF15)																						
NP8	Individual air supply spacer (with φ 8 fitting for GF15)																						
NRM	Individual exhaust spacer (with M5 female thread for GF10)																						
NR6	Individual exhaust spacer (with φ 6 fitting for GF15)																						
NR8	Individual exhaust spacer (with φ 8 fitting for GF15)																						

- Notes: 1.To designate a non-locking type manual override, enter ○ in the manual override column of the designated stations in the above table.
 2.When the manifold output specifications are J (with fitting block), select from J5 or J6 in the manifold fitting specification column of the above table, and enter ○ for each station.
 3.When mounting the individual air supply or exhaust spacer, enter ○ in the spacer column of the designated stations in the above table. Note that the spacer cannot be mounted on stations other than with valve specification T1.

Quantity	set	Delivery date
----------	-----	---------------

Solenoid Valves GF Series

Monoblock manifold F type

Specifications Confirmation Form

● Fill in selections inside the thick-lined boxes.

Company name	
Name of the person in charge	
Order number	
Equipment name	

Manifold model

GF M F

Valve size
 10: 10mm width
 15: 15mm width
 18: 18mm width

Number of units
 2 ~ 20

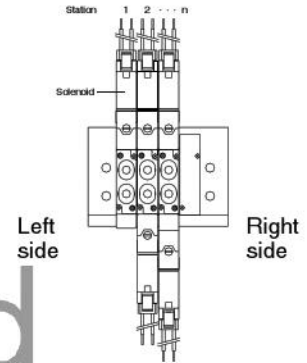

Discontinued

Illustration shows the GF10 series.

stn. GF Valve size T Valve specification - Note 1 - Note 2 - - Note 3

Valve type
FJ5: With fitting block (GF10: φ 4, GF15: φ 6, GF18: φ 8) Note 2
FJ6: With fitting block (GF10: φ 6, GF15: φ 8, GF18: φ 10) Note 2
FM: With female thread block (GF10: M5×0.8, GF15: Rc1/8, GF18: Rc1/4) Note 2

Manual override
Blank: Locking type manual override
80: Non-locking type manual override Note 1

Wiring
Blank: Grommet type, lead wire 300mm
PS: S type plug connector, lead wire 300mm
PS3: S type plug connector, lead wire 3000mm
PL: L type plug connector, lead wire 300mm
PL3: L type plug connector, lead wire 3000mm

Voltage
 DC24V
 DC12V
 AC100V
 AC200V

Individual air supply and exhaust spacer Note 3
Blank: Without spacer
NPM: Individual air supply spacer (with M5 female thread for GF10)
NP6: Individual air supply spacer (with φ 6 fitting for GF15)
NP8: Individual air supply spacer (with φ 8 fitting for GF15 and GF18)
NP0: Individual air supply spacer (with φ 10 fitting for GF18)
NRM: Individual exhaust spacer (with M5 female thread for GF10)
NR6: Individual exhaust spacer (with φ 6 fitting for GF15)
NR8: Individual exhaust spacer (with φ 8 fitting for GF15 and GF18)
NR0: Individual exhaust spacer (with φ 10 fitting for GF18)

※For the valve and block-off plate mounted at each station, enter ○ for each designated station below.

Mounting valve, block-off plate	Station	1	2	3	4	5	6	7	8	9	10	11	12	13	14	15	16	17	18	19	20	Quantities	
GF <input type="text"/> T1	2-position, single solenoid specification																						
GF <input type="text"/> T2	2-position, double solenoid specification																						
GF <input type="text"/> T3	3-position, all port block																						
GF <input type="text"/> T4	3-position, ABR connection																						
GF <input type="text"/> T5	3-position, PAB connection																						
GF <input type="text"/> BP	Block-off plate																						
Manual override (-80)	Non-locking type manual override																						
Valve type	FJ5 With fitting block																						
	FJ6 With fitting block																						
	FM With female thread block																						
NPM	Individual air supply spacer (with M5 female thread for GF10)																						
NP6	Individual air supply spacer (with φ 6 fitting for GF15)																						
NP8	Individual air supply spacer (with φ 8 fitting for GF15 and GF18)																						
NP0	Individual air supply spacer (with φ 10 fitting for GF18)																						
NRM	Individual exhaust spacer (with M5 female thread for GF10)																						
NR6	Individual exhaust spacer (with φ 6 fitting for GF15)																						
NR8	Individual exhaust spacer (with φ 8 fitting for GF15 and GF18)																						
NR0	Individual exhaust spacer (with φ 10 fitting for GF18)																						

Notes: 1. To designate a non-locking type manual override, enter ○ in the manual override column of the designated stations in the above table.
 2. Select from **FJ5**, **FJ6** or **FM** in the valve type column of the above table, and enter ○ for each station.
 3. When mounting the individual air supply or exhaust spacer, enter ○ in the spacer column of the designated stations in the above table. Note that the spacer cannot be mounted on stations other than with valve specification **T1**.

Quantity	set	Delivery date
----------	-----	---------------

Solenoid Valves GF Series

Monoblock compact manifold F type

Specifications Confirmation Form

● Fill in selections inside the thick-lined boxes.

Company name	
Name of the person in charge	
Order number	
Equipment name	

Manifold model

GF **M** **FC**

Valve size
 10: 10mm width
 15: 15mm width

Number of units
 2~20

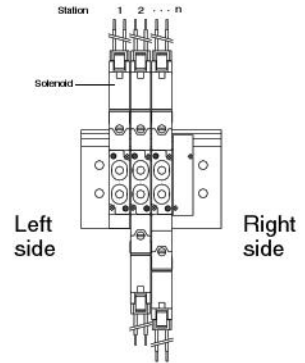

Illustration shows the GF10 series.

Discontinued

Mounting valve type

stn. **GF** Valve size **T** Valve specification - Note 1 - Note 2 - - Note 3

Valve type
FJ5: With fitting block (GF10: φ 4, GF15: φ 6)^{Note 2}
FJ6: With fitting block (GF10: φ 6, GF15: φ 8)^{Note 2}
FM: With female thread block (GF10: M5×0.8, GF15: Rc1/8)^{Note 2}

Manual override
Blank: Locking type manual override
80: Non-locking type manual override^{Note 1}

Wiring
Blank: Grommet type, lead wire 300mm
PS: S type plug connector, lead wire 300mm
PS3: S type plug connector, lead wire 3000mm
PL: L type plug connector, lead wire 300mm
PL3: L type plug connector, lead wire 3000mm

Individual air supply and exhaust spacer^{Note 3}
Blank: Without spacer
NPM: Individual air supply spacer (with M5 female thread for GF10)
NP6: Individual air supply spacer (with φ 6 fitting for GF15)
NP8: Individual air supply spacer (with φ 8 fitting for GF15)
NRM: Individual exhaust spacer (with M5 female thread for GF10)
NR6: Individual exhaust spacer (with φ 6 fitting for GF15)
NR8: Individual exhaust spacer (with φ 8 fitting for GF15)

Voltage
 DC24V
 DC12V
 AC100V
 AC200V

※For the valve and block-off plate mounted at each station, enter ○ for each designated station below.

Mounting valve, block-off plate	Station	1	2	3	4	5	6	7	8	9	10	11	12	13	14	15	16	17	18	19	20	Quantities	
GF <input type="checkbox"/> T1	2-position, single solenoid specification																						
GF <input type="checkbox"/> T2	2-position, double solenoid specification																						
GF <input type="checkbox"/> T3	3-position, all port block																						
GF <input type="checkbox"/> T4	3-position, ABR connection																						
GF <input type="checkbox"/> T5	3-position, PAB connection																						
GF <input type="checkbox"/> BP	Block-off plate																						
Manual override (-80) Non-locking type manual override																							
Valve type	FJ5 With fitting block																						
	FJ6 With fitting block																						
	FM With female thread block																						
NPM	Individual air supply spacer (with M5 female thread for GF10)																						
NP6	Individual air supply spacer (with φ 6 fitting for GF15)																						
NP8	Individual air supply spacer (with φ 8 fitting for GF15)																						
NRM	Individual exhaust spacer (with M5 female thread for GF10)																						
NR6	Individual exhaust spacer (with φ 6 fitting for GF15)																						
NR8	Individual exhaust spacer (with φ 8 fitting for GF15)																						

Notes: 1.To designate a non-locking type manual override, enter ○ in the manual override column of the designated stations in the above table.
 2.Select from FJ5, FJ6 or FM in the valve type column of the above table, and enter ○ for each station.
 3.When mounting the individual air supply or exhaust spacer, enter ○ in the spacer column of the designated stations in the above table. Note that the spacer cannot be mounted on stations other than with valve specification T1.

Quantity	set	Delivery date
----------	-----	---------------

Solenoid Valves GF Series

Split manifold non-plug-in type

Specifications Confirmation Form

● Fill in selections inside the thick-lined boxes.

Company name	
Name of the person in charge	
Order number	
Equipment name	

Manifold model: **GF** **M** **N** -

Valve size
 10: 10mm width
 15: 15mm width
 18: 18mm width

Number of units
 2~20

Pilot specification
Blank: Internal pilot manifold
G: External pilot manifold

Piping block specification
JR: With fitting on right side
JL: With fitting on left side
JD: With fittings on both sides
MR: With female thread on right side
ML: With female thread on left side
MD: With female threads on both sides

Manifold output specification
J: With fitting block
M: With female thread block
Blank: With plate (direct piping type)

stn. **GF** Valve size **T** Valve specification - Note 3 - - Note 4 - - Note 5 - Note 8 - Note 6 -

Manual override
Blank: Locking type manual override
80: Non-locking type manual override

Operation method
Blank: Internal pilot type^{Note 1}
G: External pilot type^{Note 2}

Wiring
Blank: Common type, lead wire 300mm
PS: S type plug connector, lead wire 300mm
PS3: S type plug connector, lead wire 3000mm
PL: L type plug connector, lead wire 300mm
PL3: L type plug connector, lead wire 3000mm

Split
Blank: Without split
SP: For P port^{Note 6}
SR: For R port^{Note 6}
SA: For both P and R ports^{Note 6}

Individual air supply and exhaust spacer^{Note 8}
Blank: Without spacer
NPM: Individual air supply spacer (with M5 female thread for GF10)
NP6: Individual air supply spacer (with φ6 fitting for GF15)
NP8: Individual air supply spacer (with φ8 fitting for GF15 and GF18)
NP0: Individual air supply spacer (with φ10 fitting for GF18)
NRM: Individual exhaust spacer (with M5 female thread for GF10)
NR6: Individual exhaust spacer (with φ6 fitting for GF15)
NR8: Individual exhaust spacer (with φ8 fitting for GF15 and GF18)
NR0: Individual exhaust spacer (with φ10 fitting for GF18)

Valve type
A1: With plate (When manifold output specifications are **J** or **M**, the valve type is **A1**)
FJ5: With fitting block (Can be selected when manifold output specification is "Blank," valve output fittings **GF10**: φ4, **GF15**: φ6, **GF18**: φ8)^{Note 4}
FJ6: With fitting block (Can be selected when manifold output specification is "Blank," valve output fittings **GF10**: φ6, **GF15**: φ8, **GF18**: φ10)^{Note 4}
FM: With female thread block (Can be selected when manifold output specification is "Blank," valve output female thread **GF10**: M5 x 0.8, **GF15**: Rc1/8, **GF18**: Rc1/4)^{Note 4}

※For the valve and block-off plate mounted at each station, enter ○ for each designated station below.

Mounting valve type	Station	1	2	3	4	5	6	7	8	9	10	11	12	13	14	15	16	17	18	19	20	Quantities
GF□T1	2-position, single solenoid specification																					
GF□T2	2-position, double solenoid specification																					
GF□T3	3-position, all port block																					
GF□T4	3-position, ABR connection																					
GF□T5	3-position, PAB connection																					
GF□BPN	Block-off plate																					
Manual override (-80)	Non-locking type manual override																					
Valve type	FJ5 With fitting block																					
	FJ6 With fitting block																					
	FM With female thread block																					
Manifold Fitting Specification	J5 Manifold side fitting																					
	J6 Manifold side fitting																					
Split (-SP)	For P port ^{Note 7}																					
Split (-SR)	For R port ^{Note 7}																					
Split (-SA)	For both P and R ports ^{Note 7}																					
NPM	Individual air supply spacer (with M5 female thread for GF10)																					
NP6	Individual air supply spacer (with φ6 fitting for GF15)																					
NP8	Individual air supply spacer (with φ8 fitting for GF15 and GF18)																					
NP0	Individual air supply spacer (with φ10 fitting for GF18)																					
NRM	Individual exhaust spacer (with M5 female thread for GF10)																					
NR6	Individual exhaust spacer (with φ6 fitting for GF15)																					
NR8	Individual exhaust spacer (with φ8 fitting for GF15 and GF18)																					
NR0	Individual exhaust spacer (with φ10 fitting for GF18)																					

- Notes: 1. Cannot be mounted on the external pilot manifold.
 2. Cannot be mounted on the internal pilot manifold.
 3. To designate a non-locking type manual override, enter ○ in the manual override column of the designated stations in the above table.
 4. When the manifold output specifications are "Blank," select from **FJ5**, **FJ6** or **FM** in the valve type column of the above table, and enter ○ for each station.
 5. When the manifold output specifications are **J** (with fitting block), select from **J5** or **J6** in the manifold fitting specification column of the above table, and enter ○ for each station.
 6. To designate a split, enter ○ in the split column of the designated stations in the above table.

7. Split can be mounted as long as piping blocks are attached to both sides. In addition, the number of splits that can be mounted on one manifold set is limited to one location (one station). Splits are equipped at time of delivery in the space between the designated station and the station to its left (the side with the smaller station number).
 8. When mounting the individual air supply or exhaust spacer, enter ○ in the spacer column of the designated stations in the above table. Note that the spacer cannot be mounted on stations other than with valve specification **T1**.

Quantity	set	Delivery date
----------	-----	---------------