

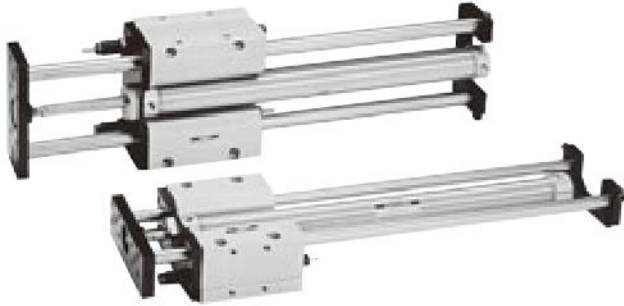

CAD drawing data catalog  
is available.



# KOGANEI

## ACTUATORS GENERAL CATALOG

# CYLINDERS WITH GUIDES GA SERIES CONTENTS

CYLINDERS WITH GUIDES GA SERIES

Specifications/Order Codes	739
Inner Construction, Major Parts and Materials	740
Dimensions	741
Allowable Load at the End Plate, and Guide Plate Eccentricities	742
Handling Instructions and Precautions	743

# Discontinued



**Caution**

Before use, be sure to read the "Safety Precautions" on p. 57.

# CYLINDERS WITH GUIDES



## Symbol

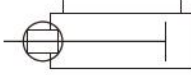

## Specifications

Item	Bore size mm [in.]	20 [0.787]	25 [0.984]	32 [1.260]	40 [1.575]
Operation type		Double acting type			
Media		Air			
Mounting type		Upper surface mounting, Lower surface mounting, Side mounting			
Operating pressure range MPa [psi.]		0.14~0.9 [20~131]	0.12~0.9 [17~131]		
Proof pressure MPa [psi.]		1.32 [191]			
Operating temperature range °C [°F]		0~70 [32~158]			
Operating speed range mm/s [in./sec.]		50~700 [2.0~27.6]			
Cushion	Standard	None			
	Option	Shock absorber			
Lubrication		Not required			
Non-rotating accuracy		±0.025° or less			
Stroke adjusting range mm [in.]		-10~0 [-0.394~0] (per side)			
Port size		Rc1/8			

## Bore Size and Stroke

Bore size	Standard strokes Note							
	mm							
20	50	75	100	125	150	200	250	300
25	50	75	100	125	150	200	250	300
32	50	75	100	125	150	200	300	350 400
40	50	75	100	125	150	200	300	350 400

Note: Consult us for strokes other than the standard strokes.

## Order Codes

**GA** **DA 20×50-A** — [ ] — [ ] — [ ] — [ ] — [ ]

**Cylinder status**  
**N** [ Bore size ] × [ Stroke ]  
 : No cylinder  
**DA** [ Bore size ] × [ Stroke ] -A  
 : With cylinder

**Stroke adjusting screw**  
**Blank** — No stroke adjusting screw  
**S1** — With 1 stroke adjusting screw (Head side)  
**S2** — With 2 stroke adjusting screws (Head side, rod side)

**Number of sensor switches**  
**1** — With 1 sensor switch  
**2** — With 2 sensor switches  
**3** — With 3 sensor switches  
 ⋮

**Lead wire length (Not applicable to CS□F)**  
**A** — 1000mm [39in.]  
**B** — 3000mm [118in.]

**Shock absorber**  
**Blank** — No shock absorber  
**K1** — With 1 shock absorber (Head side)  
**K2** — With 2 shock absorbers (Head side, rod side)

**Sensor switch (for cylinders with sensor switches)**  
**Blank** — No sensor switch  
**ZG530** — 2-lead wire solid state type with indicator lamp DC10~28V  
**ZG553** — 3-lead wire solid state type with indicator lamp DC4.5~28V

**CS3M** — Reed switch type with indicator lamp DC10~30V AC85~230V  
**CS4M** — Reed switch type with indicator lamp DC10~30V AC85~115V  
**CS5M** — Reed switch type without indicator lamp DC3~30V AC85~115V

**CS2F** — Reed switch type with indicator lamp AC85~230V  
**CS3F** — Reed switch type with indicator lamp DC10~30V  
**CS4F** — Reed switch type with indicator lamp DC10~30V  
**CS5F** — Reed switch type without indicator lamp DC3~30V

Note: If ordering a cylinder afterward for mounting, always use a cylinder with a stroke that is at least 4mm [0.157in.] longer than the required stroke.

Remark: For order codes of single units of shock absorbers and stroke adjusting screws, see p.743.

- CS□F comes with DIN connector. All others are grommet type.
- For details of sensor switches, see p.1544.
- For the order codes for sensor switches only, and mounting bands only, see p.416.

## Application Example and Features

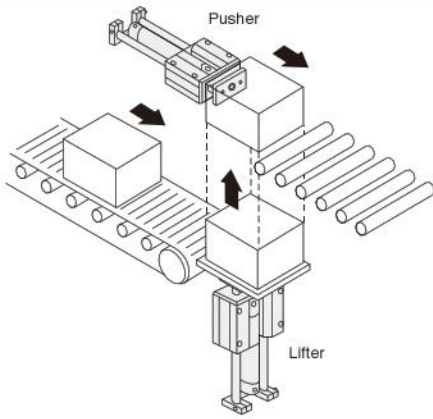

- The bore sizes of Slim cylinders are  $\phi 20$ ,  $\phi 25$ ,  $\phi 32$ , and  $\phi 40$ .  
The stroke can respond to long strokes of 50mm~400mm.
- Bearings are as standard.
- Magnets for sensor switches are as standard for all models.
- Two high-precision guide rods improve non-rotating accuracy.  
Non-rotating accuracy  $\pm 0.025^\circ$
- Enables upper surface, lower surface, and side mounting.

## Inner Construction

Diagram is for  $\phi 20$ . (With shock absorber)

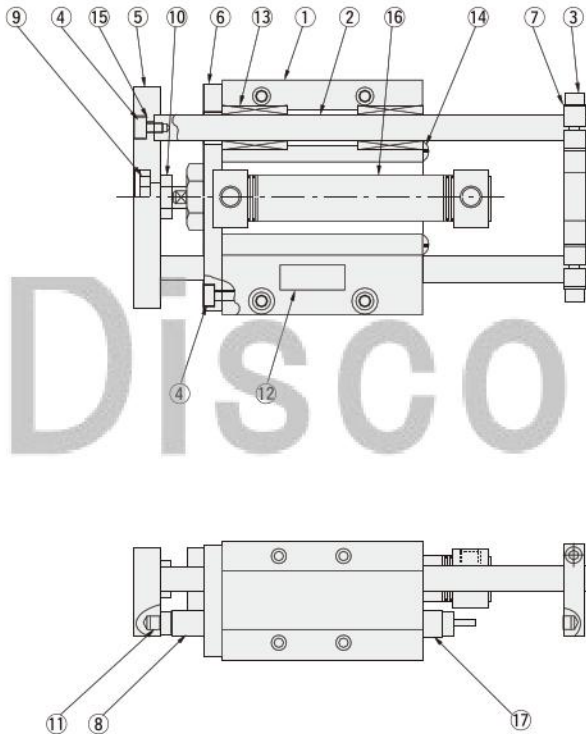

## Major Parts and Materials

No.	Parts	Materials	Remarks
①	Body	Aluminum alloy	Anodized
②	Guide rod	Steel	—
③, ④	Bolt	Steel	Nickel plated
⑤	Guide plate		
⑥	Plate F		
⑦	End plate		
⑧	Stroke adjusting screw	Mild steel	Black oxide
⑨	Joint nut A		Zinc plated
⑩	Joint nut B	Steel	—
⑪	Striker pin		
⑫	Label	—	Linear ball bearing
⑬	Bearing		
⑭	Screw	Mild steel	Zinc plated
⑮	Washer	Spring steel	
⑯	Slim cylinder <sup>Note</sup>	—	—
⑰	Shock absorber <sup>Note</sup>	—	—

Note: Slim cylinders and shock absorbers correspond to their respective standard products.

## Mass

### ● For GAN (Without cylinder)

kg [lb.]

Bore size mm [in.]	Zero stroke mass	Additional mass for each 1mm [0.0394in.] stroke	1 stroke adjusting screw	1 shock absorber
20 [0.787]	2.007 [4.425]	0.0018 [0.0040]	0.037 [0.082]	0.043 [0.095]
25 [0.984]	3.533 [7.789]	0.0032 [0.0071]	0.09 [0.198]	0.102 [0.225]
32 [1.260]	4.146 [9.141]	0.0032 [0.0071]	0.09 [0.198]	0.102 [0.225]
40 [1.575]	6.868 [15.142]	0.005 [0.011]	0.134 [0.295]	0.144 [0.318]

### ● For GADA (With cylinder)

kg [lb.]

Bore size mm [in.]	Zero stroke mass	Additional mass for each 1mm [0.0394in.] stroke	1 stroke adjusting screw	1 shock absorber
20 [0.787]	2.157 [4.756]	0.0026 [0.0057]	0.037 [0.082]	0.043 [0.095]
25 [0.984]	3.733 [8.230]	0.0043 [0.0095]	0.09 [0.198]	0.102 [0.225]
32 [1.260]	4.456 [9.824]	0.0047 [0.0104]	0.09 [0.198]	0.102 [0.225]
40 [1.575]	7.318 [16.134]	0.0074 [0.0163]	0.134 [0.295]	0.144 [0.318]

# Dimensions of Cylinders with Guides (mm)

GADA Bore size × Stroke -K -S

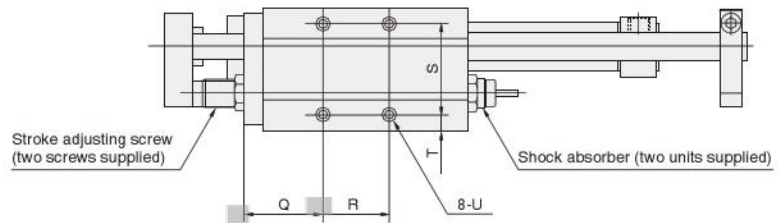
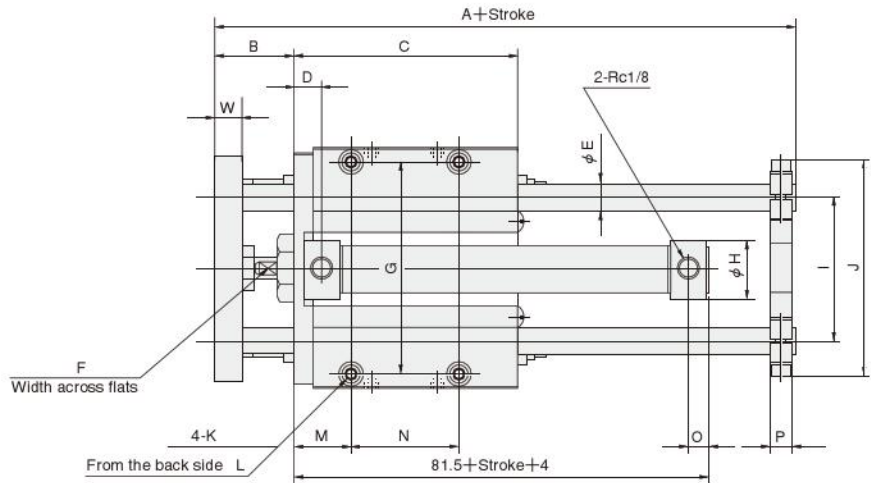
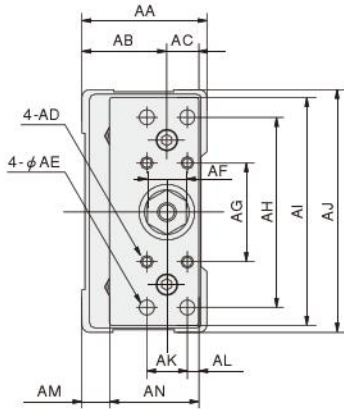
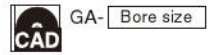

Note: Drawings show φ 20.

Bore mm [in.]	Code	A	B	C	D	E	F	G	H	I	J	K	L
20 [0.787]		159	(35)	100	12.5	12	6	94	27	64	(96)	φ 6.6 Thru hole φ 11 Counterbore, Depth 6.5	M8×1.25 Depth 12
25 [0.984]		194	(38)	120	12.5	16	8	114	29	76	(114)	φ 6.6 Thru hole φ 11 Counterbore, Depth 6.5	M8×1.25 Depth 12
32 [1.260]		204	(43)	130	12.5	16	10	122	35	84	(122)	φ 6.6 Thru hole φ 11 Counterbore, Depth 6.5	M8×1.25 Depth 12
40 [1.575]		232	(43)	154	12.5	20	14	144	41.6	100	(148)	φ 9 Thru hole φ 14 Counterbore, Depth 8.6	M12×1.75 Depth 18

Bore mm [in.]	Code	M	N	O	P	Q	R	S	T	U	W
20 [0.787]		26	48	9	10	35	30	40	7.5	M6×1 Depth 10	12
25 [0.984]		30	60	9	12	40	40	48	8	M6×1 Depth 10	12
32 [1.260]		30	70	9	12	40	50	53	8	M8×1.25 Depth 12	12
40 [1.575]		30	94	9	15	45	64	63	8	M8×1.25 Depth 12	15

Bore mm [in.]	Code	AA	AB	AC	AD	AE	AF	AG	AH	AI	AJ	AK	AL	AM	AN
20 [0.787]		55	37.5	14.5	M6×1	6.6	17	44	84	102	108	18	(5.5)	11.5	40.5
25 [0.984]		64	43	18.5	M6×1	6.6	19	50	100	123	128	24	(6.5)	11.5	50
32 [1.260]		69	47	18.5	M6×1	6.6	19	50	110	124	136	24	(6.5)	12.5	53
40 [1.575]		79	54	22.5	M8×1.25	9	22	60	130	150	164	30	7.5	14.5	62

# Allowable Load at the End Plate, and Guide Plate Eccentricities

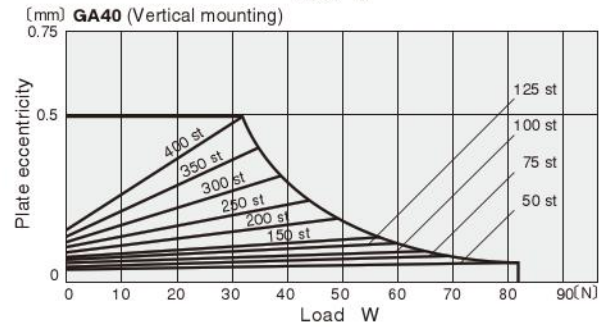
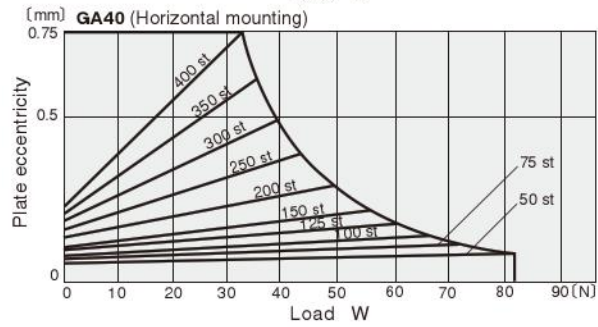
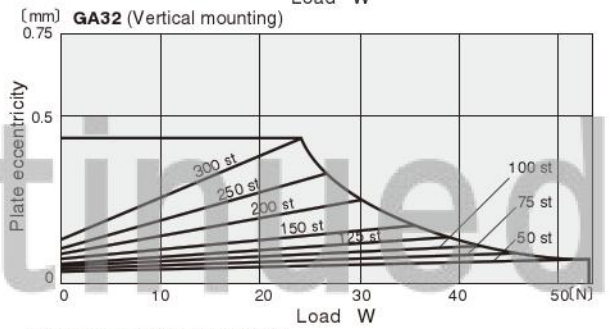
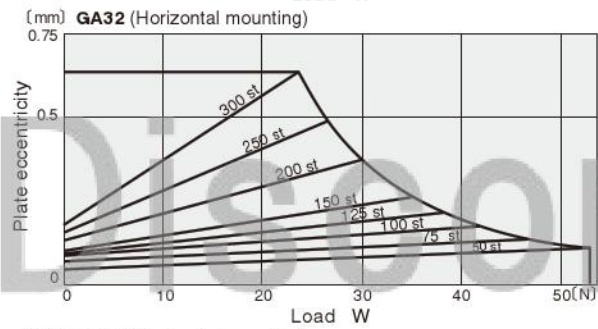
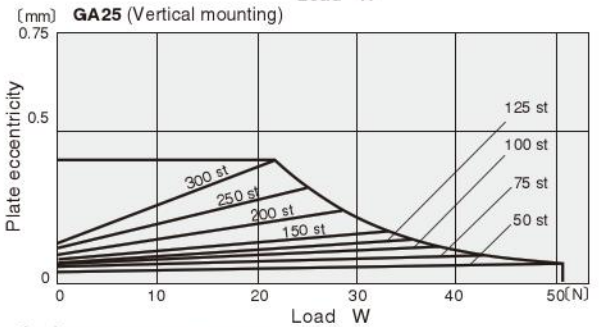
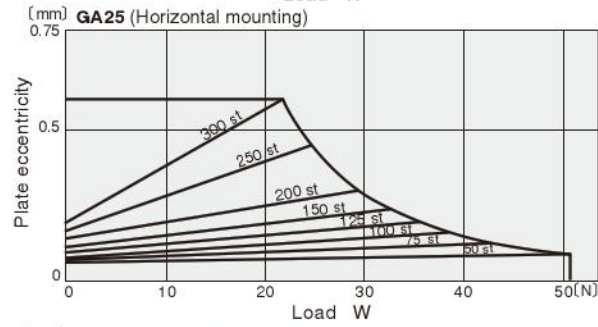
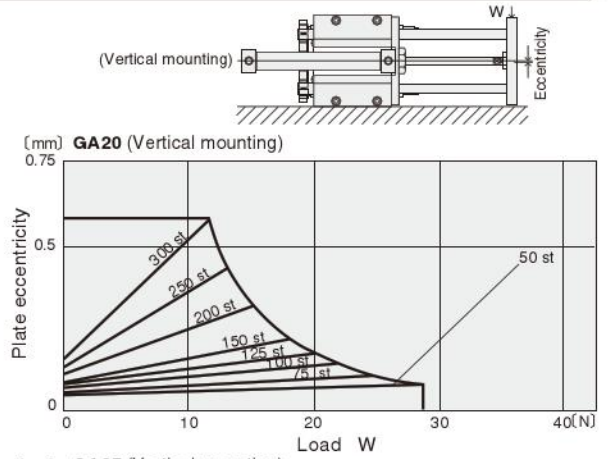
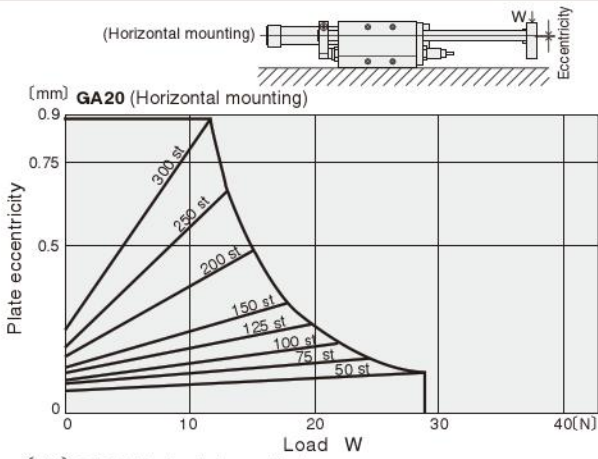

1mm = 0.0394in.  
 1N = 0.2248lbf.  
 1N·cm = 0.08851in·lbf

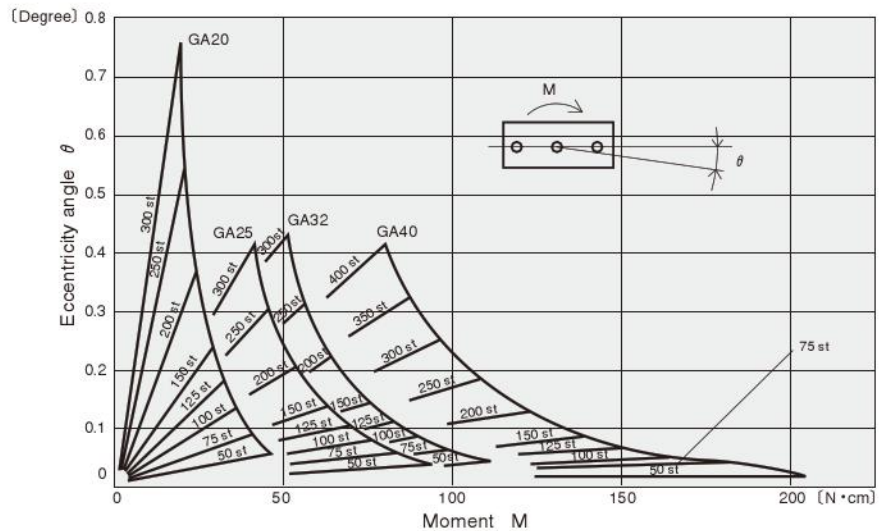

# Handling Instructions and Precautions



## Mounting and adjustment

### Stroke adjustment

The Cylinders with Guides GA series can be used with a shortened stroke on the extended side.

Loosen the tightening bolt on the end plate and move the plate, then find the mounting balance between the plate and the double guide rod, and follow the tightening torque shown below to firmly secure in place.

N·m [ft·lbf]	
Bore size	Tightening torque
20, 25	2.94 [2.17]
32	4.9 [3.61]
40	11.8 [8.70]

### Shock absorbers and stroke adjusting screws

For the Cylinders with Guides GA Series, shock absorbers and stroke adjusting screws can be separately ordered as a single unit from the other options.

#### Shock absorber order code

For GA20 and GAN20 : **KSHE6** × 10

For GA25 and GAN25 : **KSHE8** × 15

For GA32 and GAN32 : **KSHE8** × 15

For GA40 and GAN40 : **KSHE10** × 20

#### Stroke adjusting screw order code

For GA20 and GAN20 : **GAS20**

For GA25 and GAN25 : **GAS25**

For GA32 and GAN32 : **GAS32**

For GA40 and GAN40 : **GAS40**



## General precautions

### Piping

Always thoroughly blow off (use compressed air) the tubing before connecting it to the cylinder. Entering chips, sealing tape, rust, etc., generated during piping work could result in air leaks or other defective operation.

### Atmosphere

1. If using in locations subject to dripping water, dripping oil, etc., or to large amounts of dust, use a cover to protect the unit.
2. The product cannot be used when the media or ambient atmosphere contains any of the substances listed below.  
Organic solvents, phosphate ester type hydraulic oil, sulphur dioxide, chlorine gas, or acids, etc.

### Lubrication

The product can be used without lubrication, if lubrication is required, use Turbine Oil Class 1 (**ISO VG32**) or equivalent.  
Avoid using spindle oil or machine oil.

### Media

1. Use air for the media. For the use of any other media, consult us.
2. Air used for the Cylinder with Guide should be clean air that contains no deteriorated compressor oil, etc. Install an air filter (filtration of a minimum 40 µm) near the cylinder or valve to remove collected liquid or dust. In addition, drain the air filter periodically.

- For detailed specifications, special specifications, etc., regarding the Cylinders with Guides GA Series, consult us.