

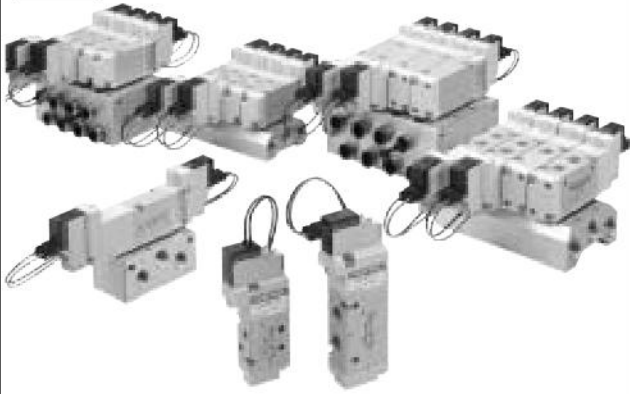

Presenting our CAD drawing
data catalog



KOGANEI

VALVES GENERAL CATALOG

SOLENOID VALVES

G110, G180 SERIES

INDEX

Characteristics	186
Handling Instructions and Precautions	188
G110 Series	191
Specifications	193
Cylinder Operating Speed	195
Solenoid Valve Order Code	196
Manifold Order Code	197
Operating Principle and Symbol	198
Dimensions	199
G180 Series	203
Specifications	205
Cylinder Operating Speed	207
Solenoid Valve Order Code	208
Manifold Order Code	209
Operating Principle and Symbol	210
Dimensions	211

Discontinued

Best Price & Global Model

G110, G180 SERIES SOLENOID VALVES

The high-performance 110, 180 series solenoid valve, in combination with the low power consumption G010 solenoid valves, offer the "best price & global model," achieving the basic performance required of a solenoid valve.

G010 series solenoid valves are used as the pilot valve. It achieves a low power consumption of 0.5W (DCV).

Wiring specifications:
 Grommet (standard)
 Straight connector, L connector (option)
 Lead wire length 1000mm, 3000mm (made to order)

Manual override:
 Non-locking type (standard)
 Locking type (option)

Standard type
 Simple form emphasizes basic performance, for versatile applications at the best price.

The solenoid valves of both 100, 180 series and of G110, G180 series can be mounted on the F, FE, A, and AJ type manifolds.

The G110, G180 series solenoid valves' mounting is compatible with 100, 180 series manifolds.

(Note, however, that the outer shape of the G110, 180 series are different from that of 110, 180 series. Confirm the outer dimensions before use.)

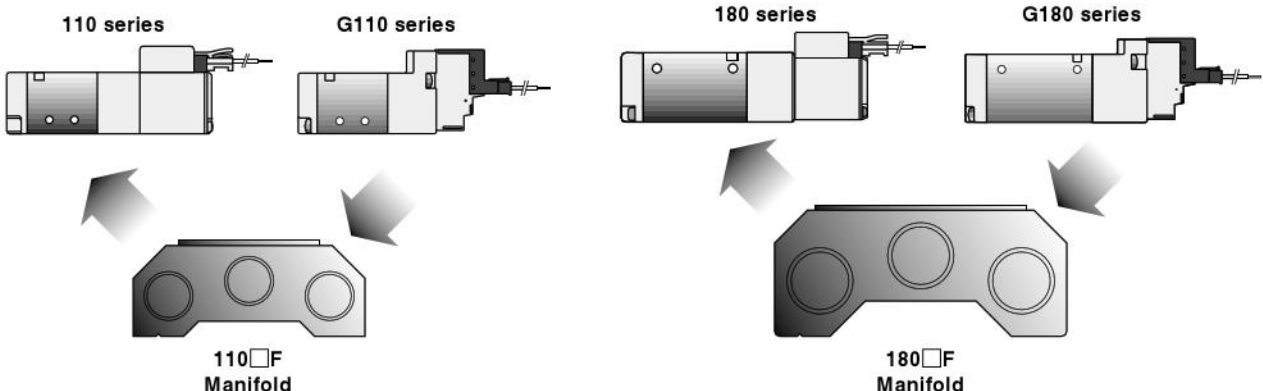

F type manifold

Low-priced type. Direct piping type valves can be mounted directly on this manifold. FE type (P, R, PR) manifold is also available.

AJ type manifold

Combines all ports into a manifold base. Quick fittings are installed into the output (A, B) ports, achieving excellent assembly and maintenance in a confined space.

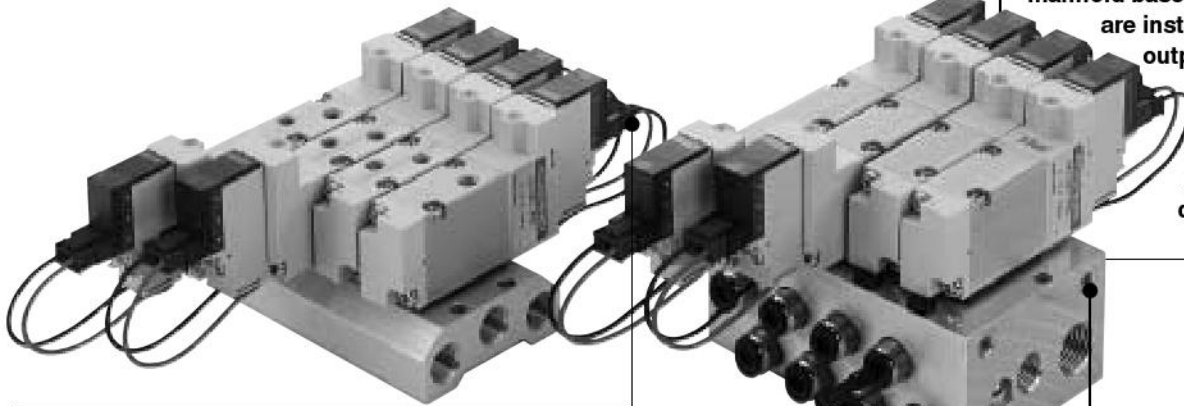

Lead wire for common wiring. Using the lead wire for common wiring provided as additional part saves on wiring work.

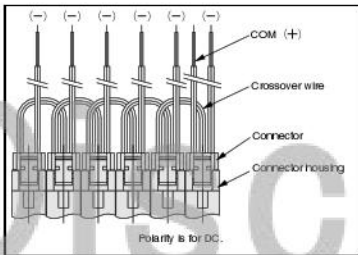

For the output port quick fittings, select from $\phi 4$ or $\phi 6$ tubes for each station in accordance with actuator size.

Pipings to the pilot exhaust ports is also possible, to keep the control box inside and working environment from becoming contaminated. The built-in check mechanism prevents exhaust interference.

The solenoid equipped with a bridge diode for AC and a flywheel diode for DC as standard offers complete surge suppression.

A manual override (non-lock type) is standard equipment, offers easy adjustment during assembly and maintenance. A locking type manual override is also available as an option.

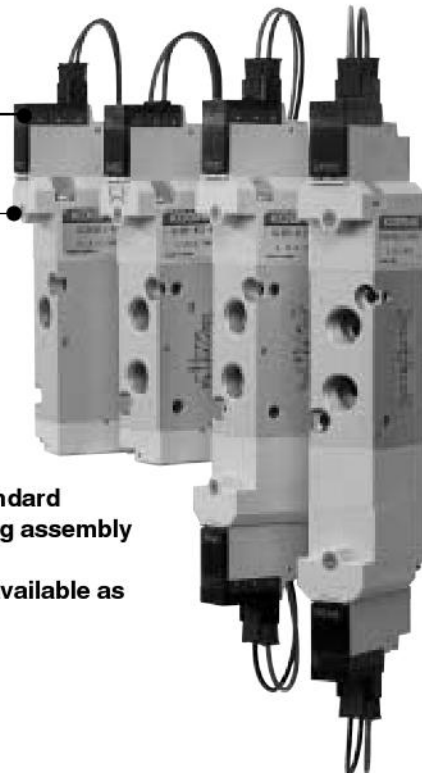



Solenoid

Internal circuit

● DC12V, DC24V

Solenoid with LED Indicator (surge suppression)

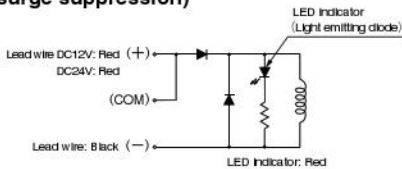

● AC100V, AC200V

Solenoid with LED Indicator (surge suppression)

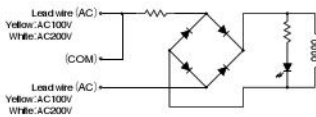

- Cautions:**
1. Do not apply megger between the lead wires.
 2. While there is no danger with a DC solenoid of a short circuit due to the wrong polarity, the valve will not operate.
 3. Leakage current inside the circuit could result in failure of the solenoid valve to return or in other erratic operation. Always use within the range of the allowable leakage current. If circuit conditions, etc., cause the leakage current to exceed the maximum allowable leakage current, consult us.
 4. For double solenoid, avoid energizing both solenoids simultaneously. The valve could fall into a neutral state.



Plug connector

Attaching and removing plug connector

Use fingers to insert the connector into the pin, push in until the lever claw catches on the convex section on the connector housing, and complete the connection. To remove the connector, squeeze the lever along with the connector, lift the lever claw up from the convex section on the connector housing, and pull out.

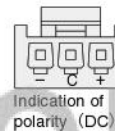
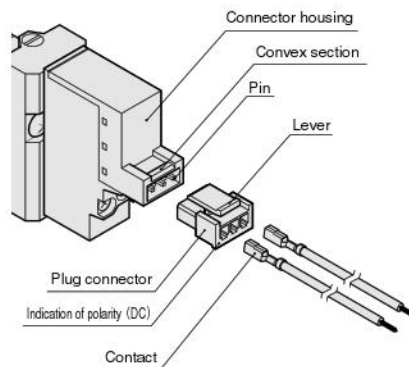

Crimping of connecting lead wire and contact

To crimp lead wires into contacts, strip off 4mm of the insulation from the tip of the lead wire, insert into the contact, and crimp it. Be sure at this time to avoid catching the insulation on the core wire as crimping section.

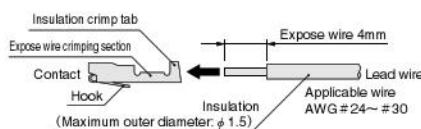

- Cautions**
1. Do not pull hard on the lead wire.
 2. Always use the dedicated tool for crimping of connecting lead wire and contact.
Contact: Model 706312-2MK
Manufactured by Sumiko Tech, Inc.
Crimping tool: Model F1
(for 706312-2MK)
Manufactured by Sumiko Tech, Inc.

Attaching and removing contact and connector

Insert the contact with lead wire into a plug connector □ hole until the contact hook catches and is secured to the plug connector. Confirm that the lead wire cannot be easily pulled out.

To remove, insert a tool with a fine tip (such as a jeweler's screwdriver) into the rectangular hole on the bottom of the plug connector to push up on the hook, and then pull out the lead wire.

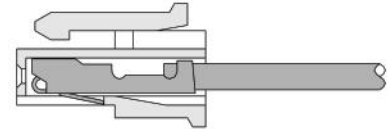

- Cautions:**
1. Do not pull hard on the lead wire. It could result in defective contacts, shorted circuit, etc.
 2. If the pin is bent, use a small screwdriver, etc., to gently straighten out the pin, and then complete the connection to the plug connector.
 3. For crimping of connecting lead wire and contact, always use a dedicated crimping tool. If a crimping tool is required, consult us.



Manual override

Non-locking type

To operate, press the manual override all the way down. The valve works the same as an energized state as long as the manual override is pushed down, and returns to the rest position upon release.

In the double solenoid, pressing the manual override on the SA(SB) side switches the state of the SA(SB) to energized state, and the unit remains in that state even after the manual override is released. To return to the rest position, operate the manual override on the SB (SA) side.

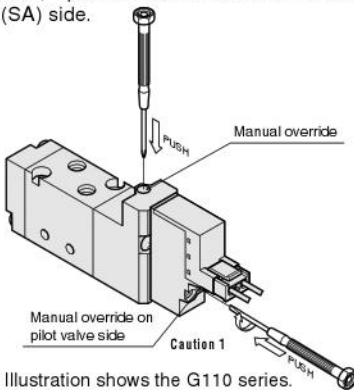

Locking type

To lock in the lock type, use a small screwdriver to push down on the manual override all the way down and turn it clockwise 90 degrees. When locked, turning the manual override 90 degrees in a counterclockwise direction releases a spring on the manual override, returns it to the original position, and releases the lock. If the manual override is never turned, this type acts just like the non-lock type, like the valve energizing status as long as the manual override is pushed down, and returning to the rest position upon release.

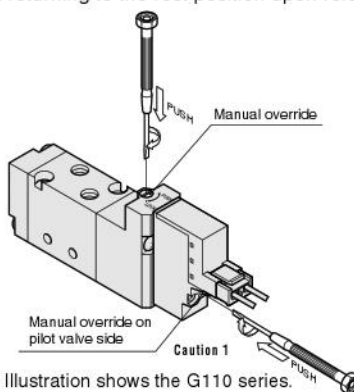

- Cautions**
1. While manual override is also possible on the pilot valve side, be sure to release the lock after completing the manual operation. Moreover, always check during valve operation to confirm that the lock on the pilot valve side has been released.
 2. Since the G110 and G180 series are internal pilot type solenoid valves, the manual override cannot switch the main valve without supplying air from the P port.
 3. Always release the lock on the lock type manual override before commencing normal operation.
 4. Do not attempt to operate the manual override with a pin or other object having an extremely fine tip. It could damage the manual override button.

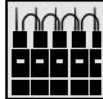

Lead wire for common wiring

Using the lead wire for common wiring, provided as additional parts, saves on wiring.

Common terminal wiring example for DC plus side and AC

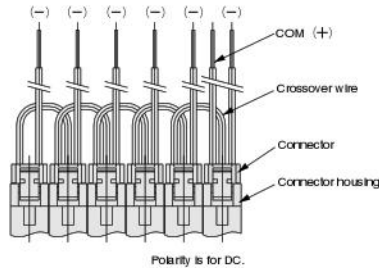

Note: The diagram shows a straight connector.

Mounting a valve on the manifold

When mounting a valve on the manifold, use the following recommended tightening torque for the valve mounting screws.
G110 series: 39.2N·cm {4kgf·cm}
G180 series: 49N·cm {5kgf·cm}

continued

Discontinued

SOLENOID VALVES G110 SERIES

INDEX

Basic Models and Configuration	192
Specifications	193
Cylinder Operating Speed	195
Solenoid Valve Order Code	196
Manifold Order Code	197
Operating Principle and Symbol	198
Dimensions of Solenoid Valve	199
Dimensions of Manifold	200
Wiring Specifications	202





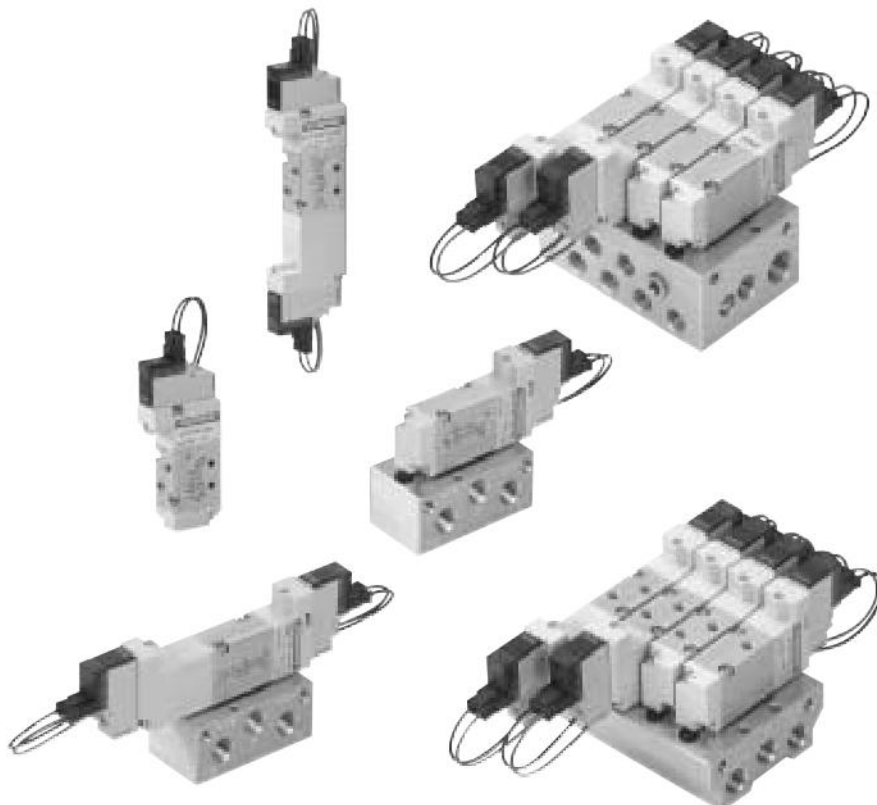







Discontinued



Basic Models and Configuration of G110 Series

Single unit

		5-port				
Direct piping	2-position	Single solenoid  G110-4E1	Double solenoid  G110-4E2	All port block  G113-4E2	3-position ABR connection  G113-4E2-13	PAB connection  G113-4E2-14
	Remark: Photo shows wiring specification -PSL.					
Sub-base piping	2-position	Single solenoid  GA110-4E1-25	Double solenoid  GA110-4E2-25	All port block  GA113-4E2-25	3-position ABR connection  GA113-4E2-13-25	PAB connection  GA113-4E2-14-25
	Remark: Photo shows wiring specification -PSL.					

Discontinued

Manifold

Manifold for combined mounting of 2-, 3-, 5-port valves

G110M□F—F type (P, R) manifold

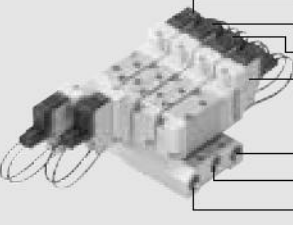

- G113-4E2, G113-4E2-13, G113-4E2-14
- G110-4E2
- G110-4E1
- G110E1, G110E1-11^{Note}
- (2-, 3-port valve for manifold only)
- 5(R1)
- 1(P)
- 3(R2)

G110M□A—A type (all port) manifold

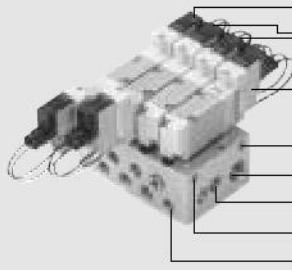

- GA113-4E2, GA113-4E2-13, GA113-4E2-14
- GA110-4E2
- GA110-4E1
- GA110E1, GA110E1-11^{Note}
- (2-, 3-port valve for manifold only)
- PR1
- 3·5(R)
- 1(P)
- PR2
- 4(A), 2(B)

G110M□FE—FE type (P, R, PR) manifold

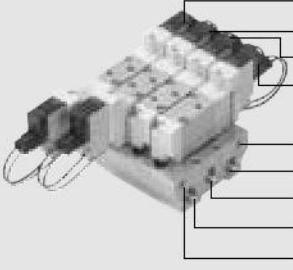

- G113-4E2, G113-4E2-13, G113-4E2-14
- G110-4E2
- G110-4E1
- G110E1, G110E1-11^{Note}
- (2-, 3-port valve for manifold only)
- PR1
- 5(R1)
- 1(P)
- 3(R2)
- PR2

G110M□AJ—AJ type (all port, with quick fitting) manifold

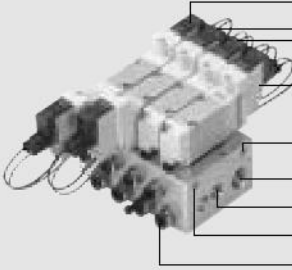

- GA113-4E2, GA113-4E2-13, GA113-4E2-14
- GA110-4E2
- GA110-4E1
- GA110E1, GA110E1-11^{Note}
- (2-, 3-port valve for manifold only)
- PR1
- 3·5(R)
- 1(P)
- PR2
- 4(A), 2(B) (with quick fitting)

Note: G110E1 and GA110E1 are dedicated valves for manifolds for combined mounting of 2-, 3-, 5-port valves. They cannot be used as a single unit.

SOLENOID VALVES G110 SERIES

Specifications

Basic Models and Functions

Item	Basic model			
	Direct piping, F, FE type manifold	G110E1 ^{Note}	G110-4E1 G110-4E2	G113-4E2
	Sub-base piping, A, AJ type manifold	GA110E1 ^{Note}	GA110-4E1 GA110-4E2	GA113-4E2
Number of positions		2 positions		3 positions
Number of ports		2, 3 ports		5 ports
Valve function		Normally closed (NC, standard) or Normally open (NO, option)	Single solenoid or Double solenoid	All port block (standard), ABR connection (option) or PAB connection (option)

Remark: For optional specifications and order code, see p. 196~197.

Note: G110E1 and GA110E1 are for manifolds for combined mounting of 2-, 3-, 5-port valves only. They cannot be used as a single unit.

Specifications

Item	Basic model			
	Direct piping, F, FE type manifold	G110E1	G110-4E1 G110-4E2	G113-4E2
	Sub-base piping, A, AJ type manifold	GA110E1	GA110-4E1 GA110-4E2	GA113-4E2
Media		Air		
Operation method		Internal pilot type		
Effective area [Cv] ^{Note 1}	mm ²	4.2 [0.23]		3.8 [0.21]
Port size ^{Note 2}		M5×0.8		
Lubrication		Not required		
Operating pressure range	MPa [kgf/cm ²]	0.15~0.7 [1.5~7.1]		
Proof pressure	MPa [kgf/cm ²]	1.05 [10.7]		
Response time ^{Note 3}	ms	DC12V, DC24V	15/25	15/40
		AC100V, AC200V	15/15	15/35
Maximum operating frequency	Hz	5		
Minimum time to energize for self holding	ms	—	50 (□110-4E2)	—
Operating temperature range (atmosphere and media)	°C	5~50		
Shock resistance	m/s ² [G]	1373.0 {140.0} (pilot valve axial direction 294.2 {30})		294.2 {30.0}
Mounting direction		Any		

Notes: 1. For details, see the effective area on p. 194.

2. For details, see the port size on p. 194.

3. Values when air pressure is 0.5MPa [5.1kgf/cm²]. For switching phase timing, add a maximum of 5 ms to the response time of AC specifications. Values in brackets [] are for G110-4E2. In addition, values for G113-4E2 are those of the all port block valve, switching from neutral state.

Remark: Conversion to psi., 1MPa=145psi., 1kgf/cm²=14.2psi., e.g. 0.7MPa=102psi.

Solenoid Specifications

Item	Rated voltage	DC12V		DC24V		AC100V ^{Note}		AC200V ^{Note}	
Operating voltage range	V	10.8~13.2 (12±10%)		21.6~26.4 (24±10%)		90~110 (100±10%)		180~220 (200±10%)	
Rated frequency	Hz	—		—		50	60	50	60
Current (When rated voltage is applied)	mA (r.m.s)	42		21		11		8	
Power consumption		0.5W		0.5W		1.1VA		1.6VA	
Maximum allowable leakage current	mA	1.0		1.0		1.0		1.0	
Insulation resistance	MΩ	Min. 100 (value at DC500V megger)							
Wiring and lead wire length		Grommet type: 300mm, Plug connector type: 300mm							
Color of lead wire		Red (+), Black (-)				Yellow		White	
Color of LED indicator		Red							
Surge suppression (as standard)		Flywheel diode				Bridge diode			

Notes: 1. Since the AC types have built-in bridge diodes, the starting current value and energizing current value are virtually the same.

2. For long-time continuous energizing, consult us.

3. Provide heat radiation measures to ensure that the ambient temperature (or when using a control box, the internal temperature of the box) always remains within the temperature range specifications.

Effective Area [Cv]

mm²

Basic model	Standard (single valve)	Built-in quick fitting	Remarks
G110E1 G110-4E1 G110-4E2	4.2 [0.23]	—	<ul style="list-style-type: none"> ● Attaching TS4-M5 to P, A, B ports brings the value to 1.8. ● On the F type manifold, attaching TS4-M5 to the A, B ports brings the value to 2.1.
G113-4E2	3.8 [0.21]		
GA110E1 GA110-4E1 GA110-4E2	4.0 [0.22]	~J4: 3.6 [0.20] ~J6: 4.0 [0.22]	<ul style="list-style-type: none"> ● When mounting on a sub-base or manifold. ● Attaching TS4-01 to the sub-base P, A, B ports brings the value to 3.2.
GA113-4E2	3.6 [0.20]	3.6 [0.20]	

Solenoid Valve Port Size

Basic model	Port specifications		Port size
G110E1 ^{Note}	Standard	Female thread	M5×0.8
G110-4E1 G110-4E2 G113-4E2	Standard	Female thread	M5×0.8
GA110-4E1-25 GA110-4E2-25 GA113-4E2-25	1(P)	Female thread	Rc1/8
	4(A), 2(B)		
	3·5(R)		
	PR	Female thread	M5×0.8

Note: Since G110E1 is for manifold only, piping to the P port with a fitting is not possible.

Manifold Connection Port Size

Manifold model	Port	Location of piping connection	Port size
G110M□F	1(P)	Manifold	Rc1/8
	4(A), 2(B)	Valve	M5×0.8
	3·5(R)	Manifold	Rc1/8
G110M□FE	1(P)	Manifold	Rc1/8
	4(A), 2(B)	Valve	M5×0.8
	3·5(R)	Manifold	Rc1/8
	PR		M5×0.8
G110M□A	1(P)	Manifold	Rc1/8
	4(A), 2(B)		
	3·5(R)		Rc1/4
	PR		M5×0.8
G110M□AJ	1(P)	Manifold	Rc1/8
	4(A), 2(B)		Quick fitting for $\phi 4$ or $\phi 6$
	3·5(R)		Rc1/4
	PR		M5×0.8

Valve Mass

g

Basic model	Mass
G110E1	53
G110-4E1	52
G110-4E2	72
G113-4E2	79
GA110E1	54 (149)
GA110-4E1	53 (148)
GA110-4E2	73 (168)
GA113-4E2	81 (176)

Remark: Figures in parentheses () are the mass with sub-base: -25.

Manifold Mass

g

Manifold model	Mass calculation of each unit (n=number of units)	Block-off plate
G110M□F	(20×n) + 30	6
G110M□FE	(40×n) + 50	11
G110M□A	(60×n) + 60	
G110M□AJ	~J4: (67×n) + 60 ~J6: (64×n) + 60	

Cylinder Operating Speed

How to obtain cylinder speed

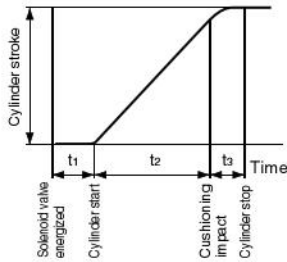

To obtain the time required for the cylinder to complete full stroke, add cylinder's delay time t_1 (time between energizing of solenoid valve and actual starting of cylinder), to the cylinder's max. operating speed time t_2 . When a cushion is used, add the cushioning time t_3 , to the above calculation. Standard cushioning time t_3 is approximately 0.2 seconds.

G110-4E1 G113-4E2

● Measurement conditions

- Air pressure: 0.5MPa (5.1kgf/cm²)
- Piping inner diameter and length: $\phi 2.5 \times 1000\text{mm}$
- Fitting: Quick fitting TS4-M5
- Load ratio = $\frac{\text{Load}}{\text{Cylinder theoretical thrust}}$ (%)
- Cylinder stroke: 150mm

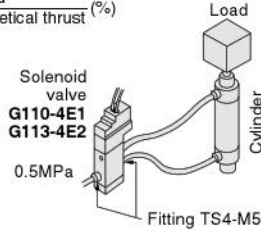

Maximum operating speed

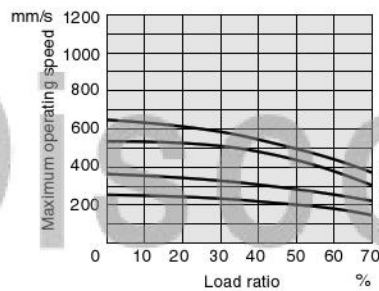

Delay time

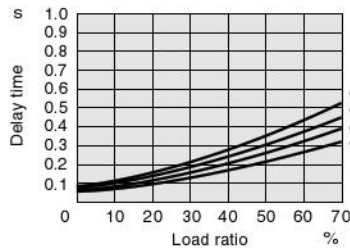

GA110-4E1-25 GA113-4E2-25

● Measurement conditions

- Air pressure: 0.5MPa (5.1kgf/cm²)
- Piping inner diameter and length: $\phi 4 \times 1000\text{mm}$
- Fitting: Quick fitting TS6-01
- Load ratio = $\frac{\text{Load}}{\text{Cylinder theoretical thrust}}$ (%)
- Cylinder stroke: 150mm

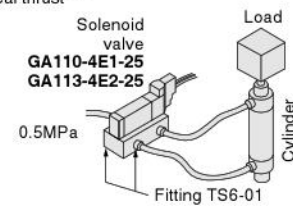

Maximum operating speed

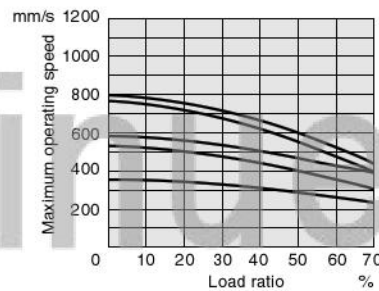

Delay time

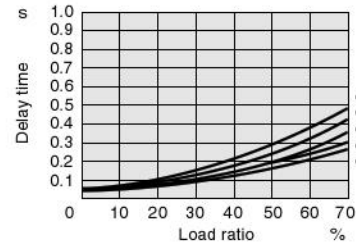

Flow Rate

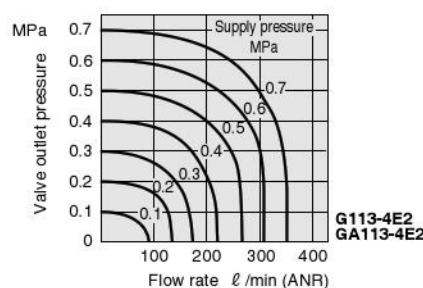
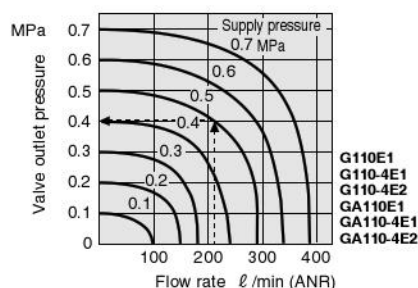

How to read the graph

If supply pressure is 0.5MPa and flow rate is 214 l/min (ANR), the valve outlet pressure becomes 0.4MPa.

G110 Series Manifold Order Code

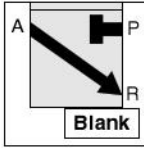
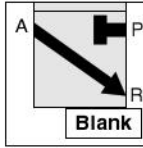
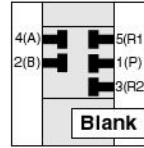
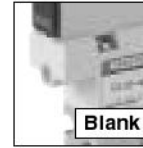
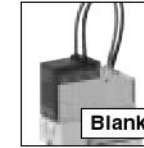
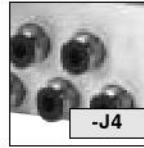
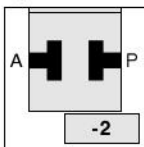
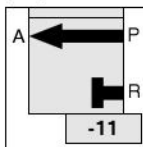
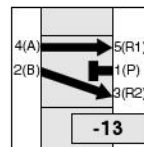
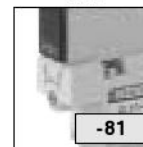
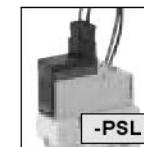
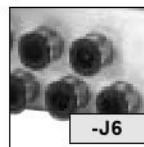
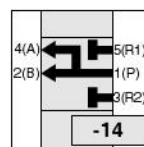
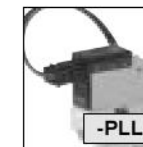
2-, 3-port valve Number of ports		2-, 3-port valve Valve function		3-position valve Valve function		Manual override		Wiring		Manifold Connection port	
3-port  Blank		Normally closed (NC)  Blank		All port block  Blank		Non-locking type  Blank		Grommet type with LED indicator  Blank		Quick fitting for ϕ 4 tube  -J4	
2-port  -2		Normally open (NO)  -11		ABR connection  -13		Locking type  -81		Straight connector with LED indicator  -PSL		Quick fitting for ϕ 6 tube  -J6	
				PAB connection  -14				L connector with LED indicator  -PLL			

Manifold model Number of units	Station	Basic model	Voltage ^{Note}				
G110M 2 ⋮ 20	F FE stn. <input type="checkbox"/> ⋮ stn. <input type="checkbox"/>	-G110E1	-2	-11	DC12V DC24V AC100V AC200V		
		-G110-4E1					
		-G110-4E2					
		-G113-4E2		-13,-14			
		-GA110E1	-2	-11			
		-GA110-4E1					
	A AJ stn. <input type="checkbox"/> ⋮ stn. <input type="checkbox"/>	-GA110-4E2				DC12V DC24V AC100V AC200V	
		-GA113-4E2		-13,-14			
					-81		-PSL -PLL
					-81		-PSL -PLL
							-J4 -J6

- Valve mounting location from the left-hand side when facing A, B port.
- Specify the valve type for each station.
- Enter -BP when closing a station with a block-off plate without mounting a valve.
- For the AJ type manifold only, specify one or the other.

Note: For AC 110V~120V or AC 220V~240V specifications, consult us.

SOLENOID VALVES G110, G180 SERIES

Operating Principle and Symbol

3-port

Normally closed (NC)

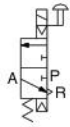

G110E1
De-energized

Normally open (NO)

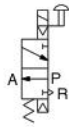

G110E1-11
De-energized

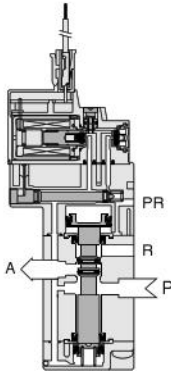
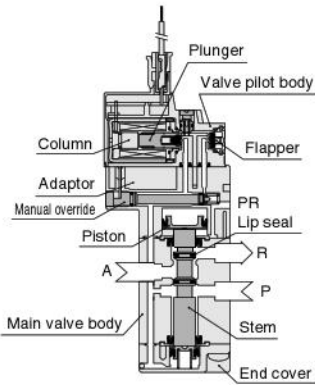

5-port, 2-position

Single solenoid

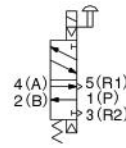

G110-4E1

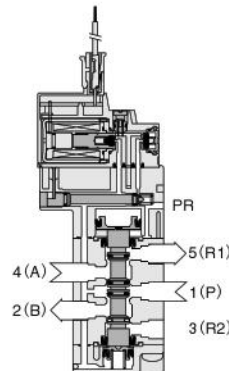

Double solenoid

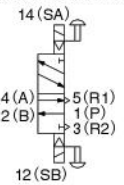

G110-4E2
(De-energized condition after energizing solenoid SA)

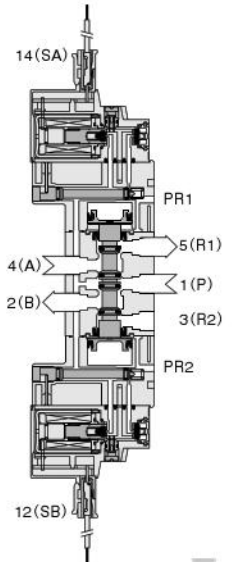

5-port, 3-position

(Both solenoid SA and SB are de-energized.)

All port block

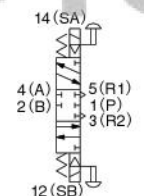

G113-4E2

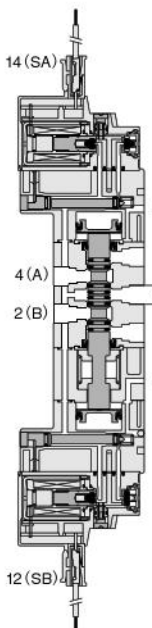

ABR connection

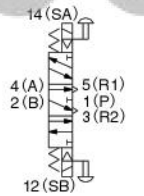

G113-4E2-13

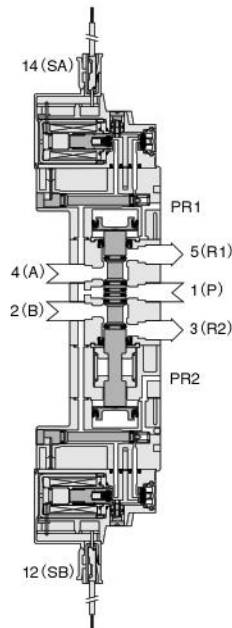

PAB connection

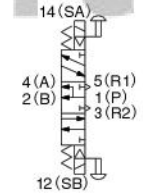

G113-4E2-14

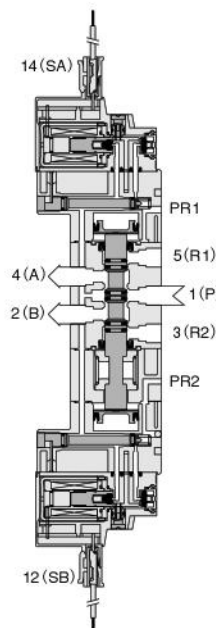

Major Parts and Materials

	Parts	Materials
Valve (main valve)	Body	Aluminum alloy (anodized)
	Stem	Aluminum alloy (anodized)
	Lip seal	Synthetic rubber
	Sub-base	Aluminum alloy (anodized)
	End cover	Aluminum alloy (anodized)
Valve (pilot)	Adapter	Plastic
	Body	Plastic
	Plunger	Magnetic stainless
Manifold	Column	Magnetic stainless
	Flapper	Synthetic rubber
	Body	Aluminum alloy (anodized)
	Block-off plate	Steel (nickel plated)
	Seal	Synthetic rubber

G110-4E1-PSL  G110_4E1

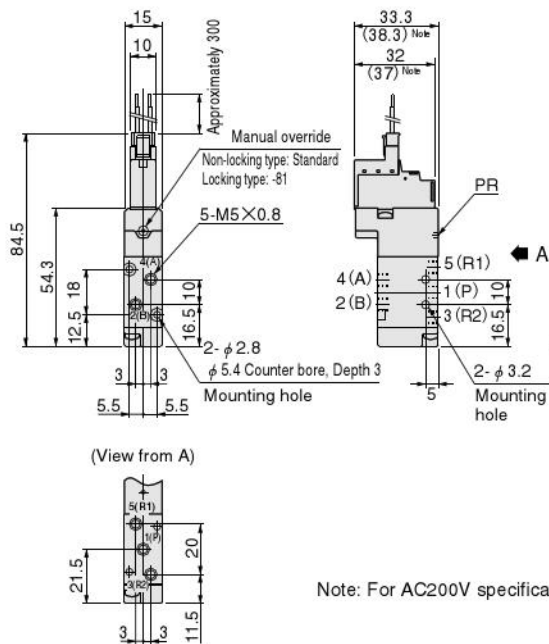

GA110E1-25-PSL

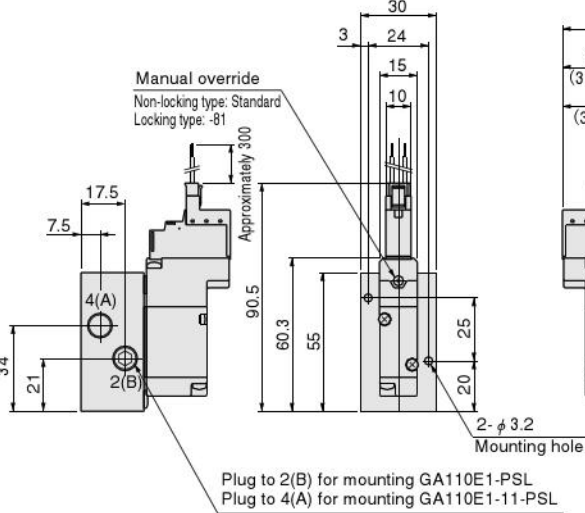

GA110-4E1-25-PSL  GA110E1

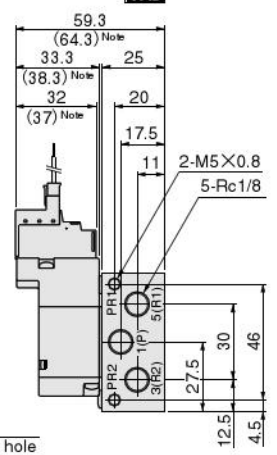

G110-4E2-PSL  G110_4E2

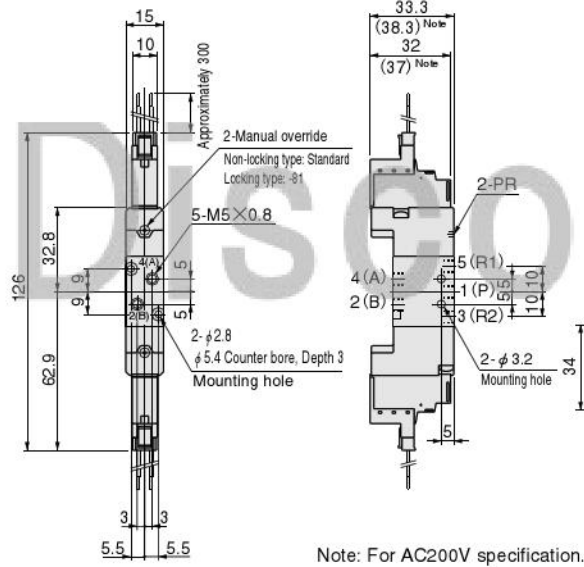

GA110-4E2-25-PSL  GA110_4E

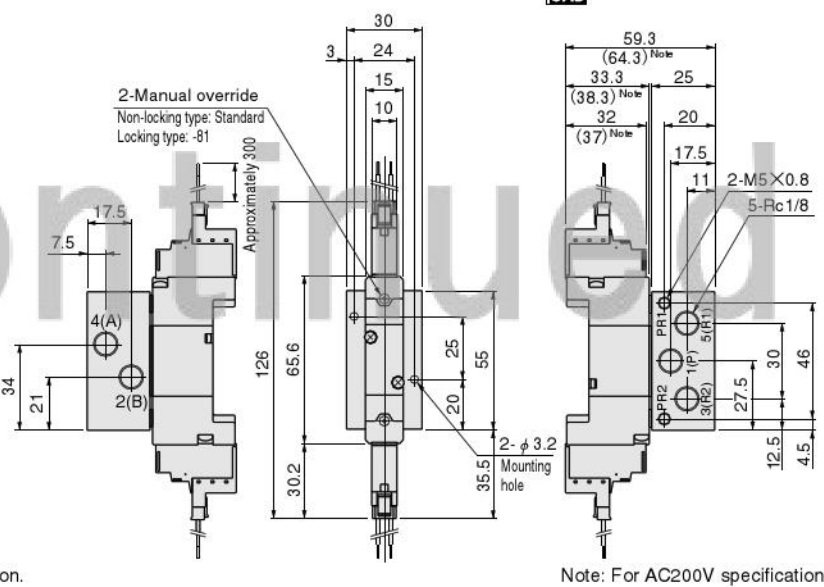

G113-4E2-PSL  G113_4E2

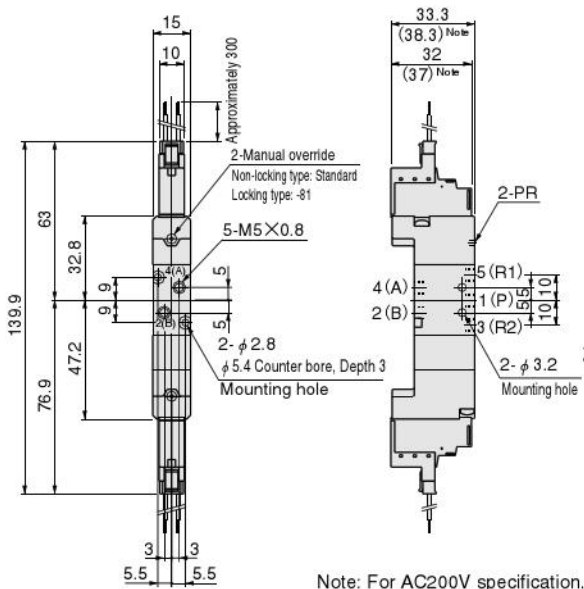

GA113-4E2-25-PSL  GA113_4E

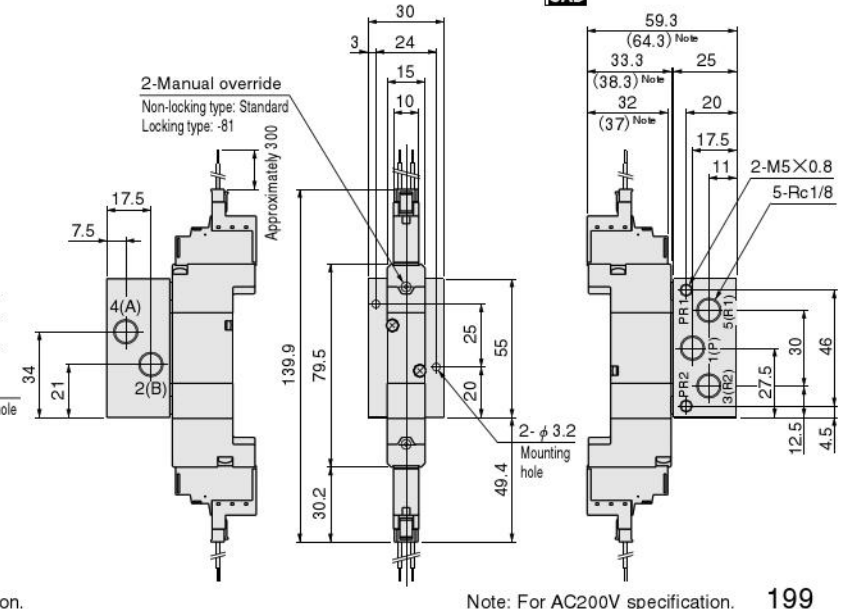

Dimensions of Manifold for Combined Mounting of 2-, 3-, 5-port Valves (Scale 1/3, Unit mm)

G110M□F

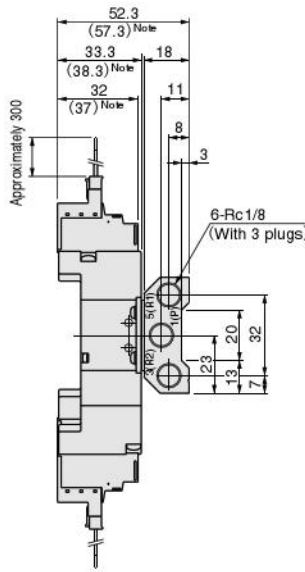
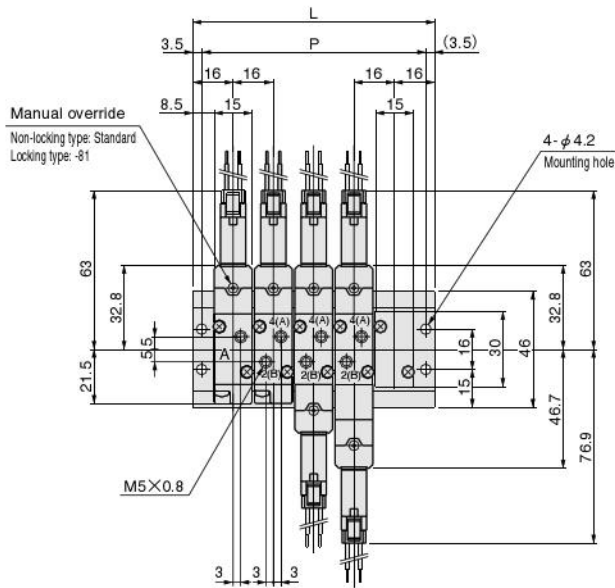
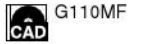

Unit dimensions

Number of units	L	P
2	48	41
3	64	57
4	80	73
5	96	89
6	112	105
7	128	121
8	144	137
9	160	153
10	176	169
11	192	185
12	208	201
13	224	217
14	240	233
15	256	249
16	272	265
17	288	281
18	304	297
19	320	313
20	336	329

Note: For AC200V specification.

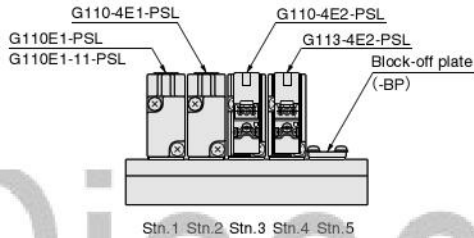

G110M□FE

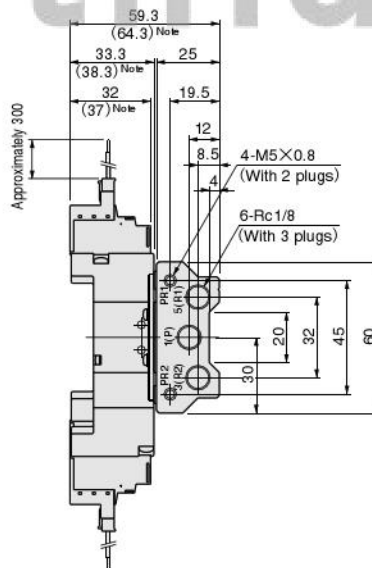
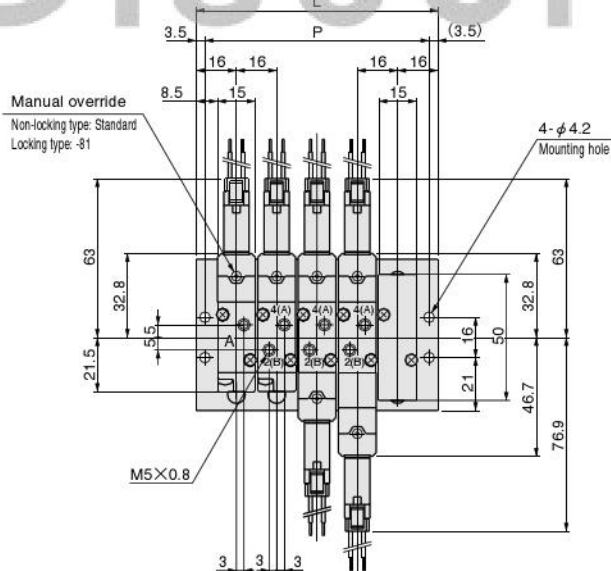

Unit dimensions

Number of units	L	P
2	48	41
3	64	57
4	80	73
5	96	89
6	112	105
7	128	121
8	144	137
9	160	153
10	176	169
11	192	185
12	208	201
13	224	217
14	240	233
15	256	249
16	272	265
17	288	281
18	304	297
19	320	313
20	336	329

Note: For AC200V specification.

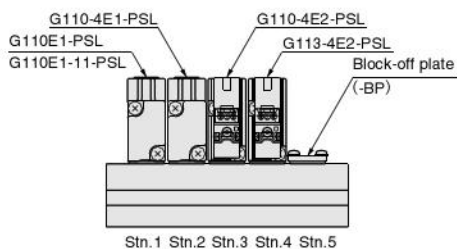

For wiring specifications, see p. 202.

G110M□A

CAD G110MA

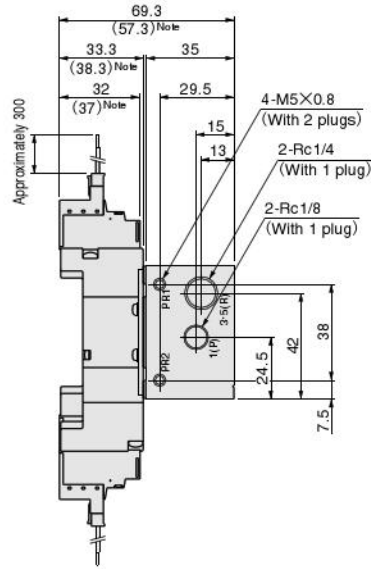
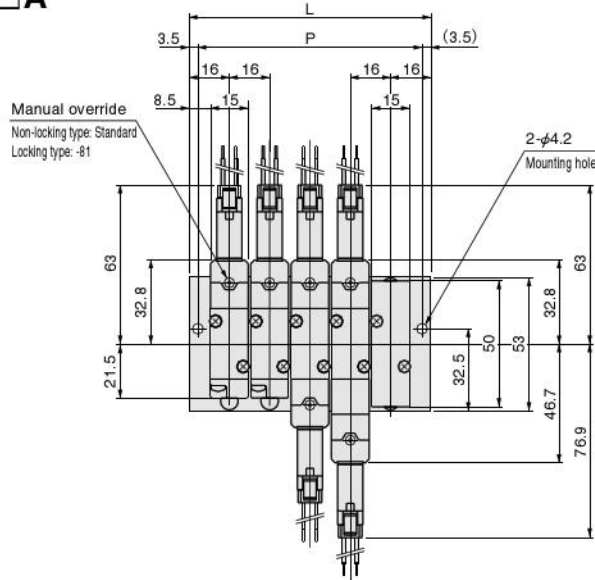

Unit dimensions

Number of units	L	P
2	48	41
3	64	57
4	80	73
5	96	89
6	112	105
7	128	121
8	144	137
9	160	153
10	176	169
11	192	185
12	208	201
13	224	217
14	240	233
15	256	249
16	272	265
17	288	281
18	304	297
19	320	313
20	336	329

Note: For AC200V specification.

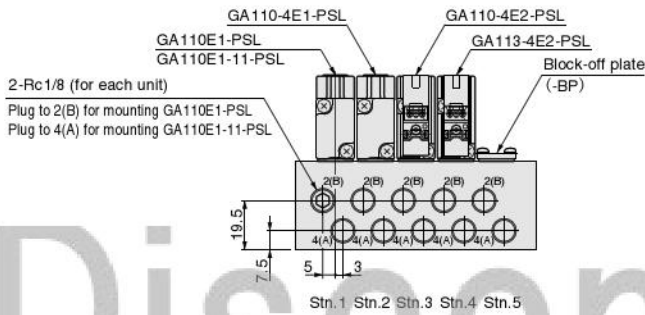

G110M□AJ

CAD G110MAJ

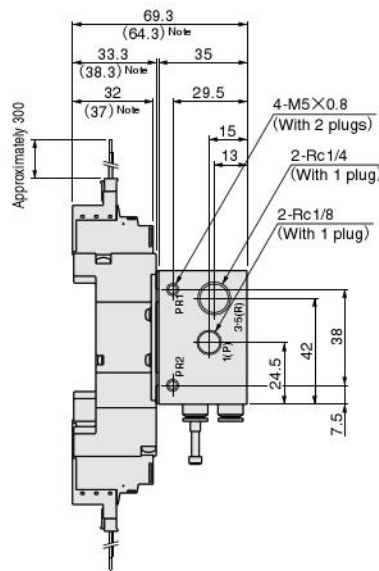
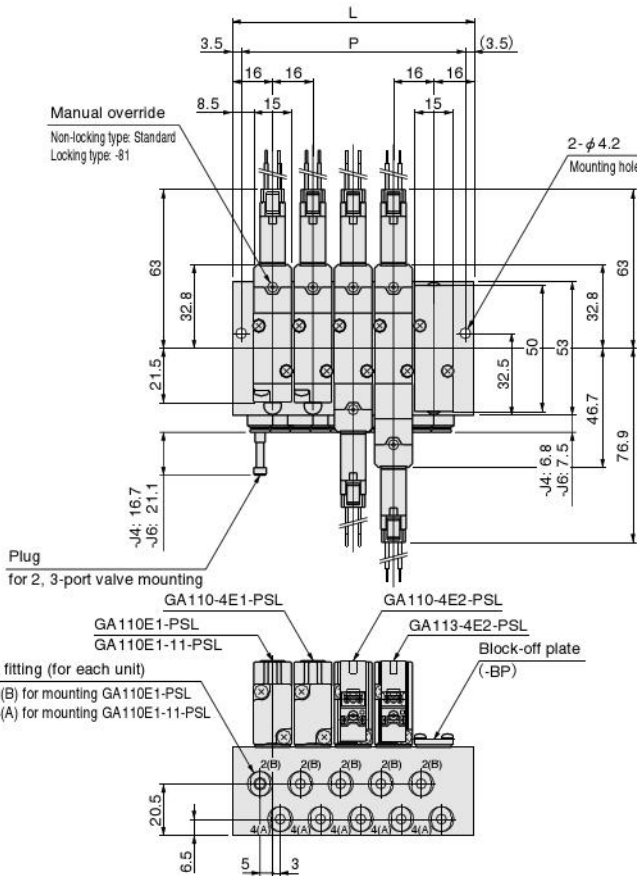

Unit dimensions

Number of units	L	P
2	48	41
3	64	57
4	80	73
5	96	89
6	112	105
7	128	121
8	144	137
9	160	153
10	176	169
11	192	185
12	208	201
13	224	217
14	240	233
15	256	249
16	272	265
17	288	281
18	304	297
19	320	313
20	336	329

Note: For AC200V specification.

For wiring specifications, see p. 202.

Stn.1 Stn.2 Stn.3 Stn.4 Stn.5

SOLENOID VALVES G110, G180 SERIES

Discontinued

■ For DC12V, 24V, AC100V

● Grommet: Blank

● Solenoid with straight connector: -PSL

● Solenoid with L connector: -PLL

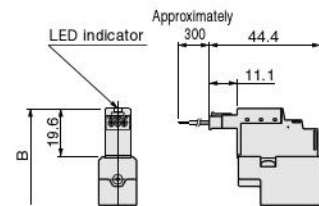
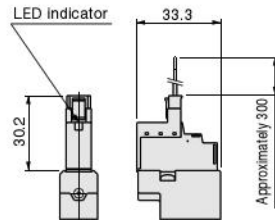
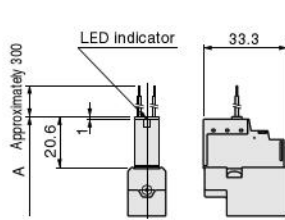

■ For AC200V

● Grommet: Blank

● Solenoid with straight connector: -PSL

● Solenoid with L connector: -PLL

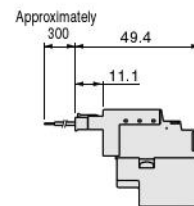
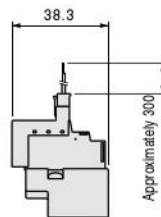
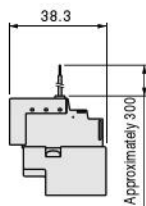

mm

Model	Code	A	B	Remarks
G110E1, G110-4E1		74.9	73.9	Length to the end of the valve or sub-base
GA110E1-25, GA110-4E1-25		80.9	79.9	
G110-4E2, GA110-4E2-25		106.8	104.8	Total length to the end of the opposite solenoid
G113-4E2, GA113-4E2-25		120.7	118.7	

SOLENOID VALVES G180 SERIES

INDEX

Basic Models and Configuration	204
Specifications	205
Cylinder Operating Speed	207
Solenoid Valve Order Code	208
Manifold Order Code	209
Operating Principle and Symbol	210
Dimensions of Solenoid Valve	211
Dimensions of Manifold	212
Wiring Specifications	214





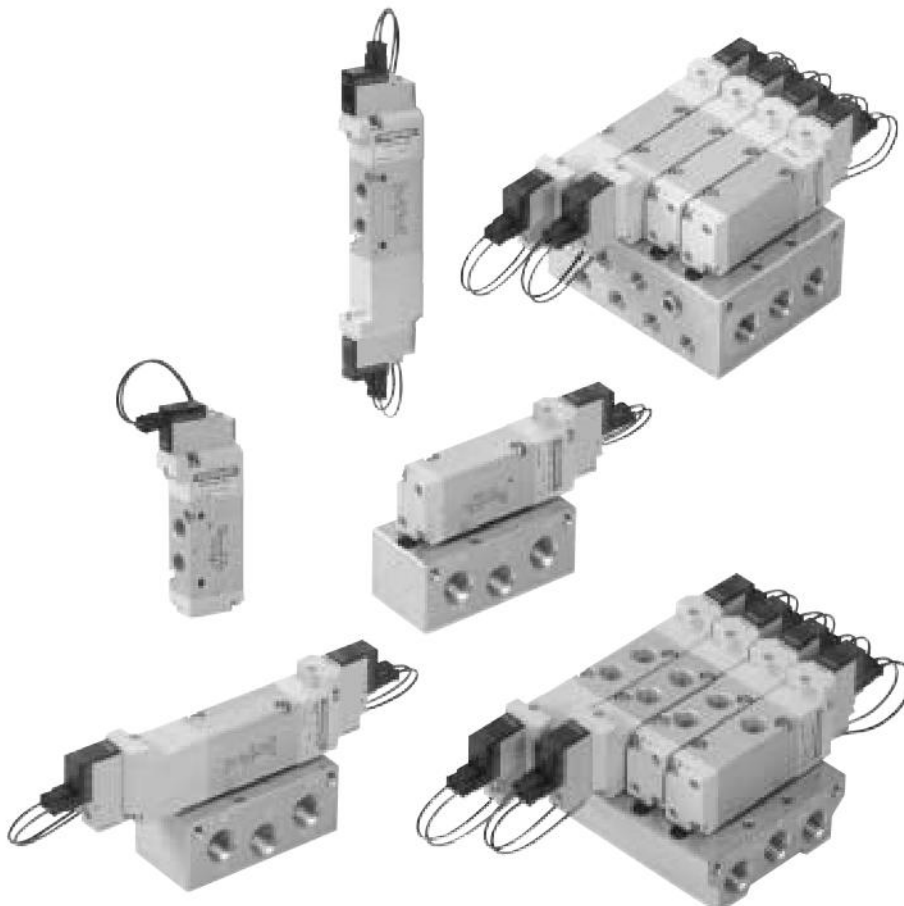





Dis G180 ed

SOLENOID VALVES G110, G180 SERIES



Basic Models and Configuration of G180 Series

Single unit

		5-port					
Direct piping	2-position	Single solenoid	Double solenoid	All port block	3-position	ABR connection	PAB connection
							
		G180-4E1	G180-4E2	G183-4E2	G183-4E2-13	G183-4E2-14	Remark: Photo shows wiring specification -PSL.
Sub-base piping	2-position	Single solenoid	Double solenoid	All port block	3-position	ABR connection	PAB connection
							
		GA180-4E1-25	GA180-4E2-25	GA183-4E2-25	GA183-4E2-13-25	GA183-4E2-14-25	Remark: Photo shows wiring specification -PSL.

Manifold

Manifold for combined mounting of 2-, 3-, 5-port valves

G180M□F—F type (P,R) manifold

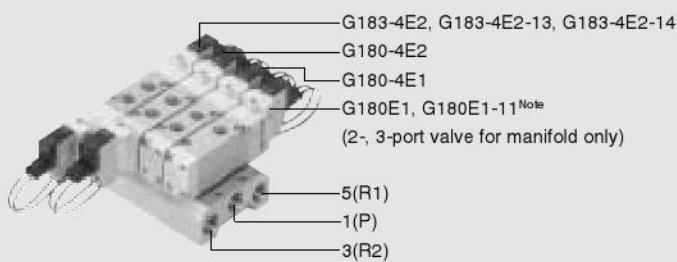

G180M□A—A type (all port) manifold

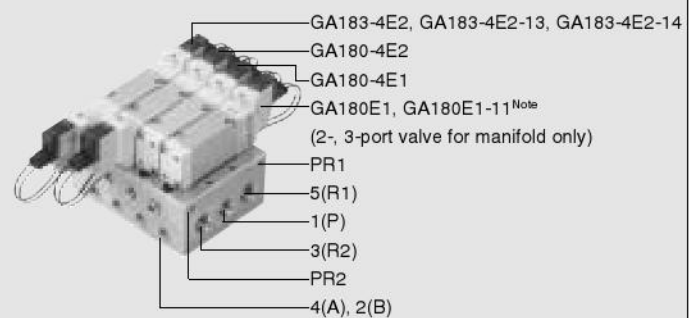

G180M□FE—FE type (P, R, PR) manifold

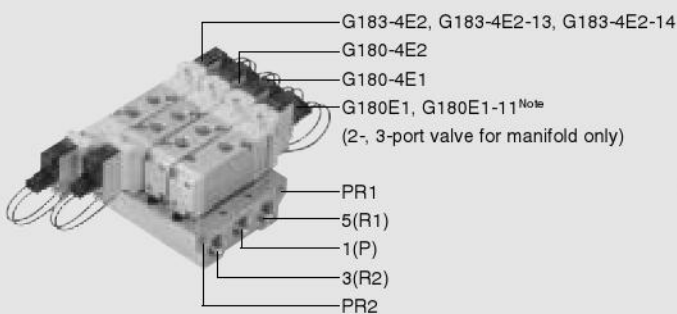

G180M□AJ—AJ type (all port, with quick fitting) manifold

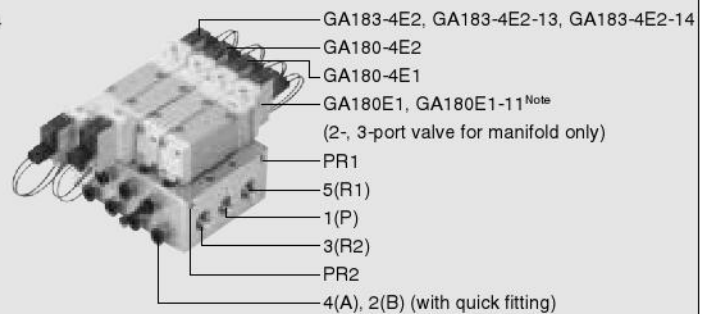

Remark: Wiring specifications of solenoid valves in photos are -PSL.

Note: G180E1 and GA180E1 are dedicated valves for manifolds for combined mounting of 2-, 3-, 5-port valves. They cannot be used as a single unit.

SOLENOID VALVES G180 SERIES

Specifications

Basic Models and Functions

Basic model	Direct piping, F, FE type manifold	G180E1 ^{Note}	G180-4E1 G180-4E2	G183-4E2
	Sub-base piping, A, AJ type manifold	GA180E1 ^{Note}	GA180-4E1 GA180-4E2	GA183-4E2
Item				
Number of positions	2 positions			3 positions
Number of ports	2, 3 ports		5 ports	
Valve function	Normally closed (NC, standard) or Normally open (NO, option)		Single solenoid or Double solenoid	All port block (standard), ABR connection or PAB connection (option)

Remark: For optional specifications and order code, see p. 208~209.

Note: G180E1 and GA180E1 are for manifolds for combined mounting of 2-, 3-, 5-port valves only. They cannot be used as a single unit.

Specifications

Basic model	Direct piping, F, FE type manifold	G180E1	G180-4E1 G180-4E2	G183-4E2
	Sub-base piping, A, AJ type manifold	GA180E1	GA180-4E1 GA180-4E2	GA183-4E2
Item				
Media	Air			
Operation method	Internal pilot type			
Effective area (Cv) ^{Note 1}	mm ²	10.2 (0.57)		9.0 (0.50)
Port size ^{Note 2}		Rc1/8		
Lubrication		Not required		
Operating pressure range	MPa (kgf/cm ²)	0.15~0.7 (1.5~7.1)		
Proof pressure	MPa (kgf/cm ²)	1.05 (10.7)		
Response time ^{Note 3}	DC12V, DC24V	20/30	20/30, [20]	20/65
	ON/OFF	AC100V, AC200V	20/25	20/55
Maximum operating frequency	Hz	5		
Minimum time to energize for self holding	ms	—	50 (□180-4E2)	—
Operating temperature range (atmosphere and media)	°C	5~50		
Shock resistance	m/s ² {G}	1373.0 (140.0) (pilot valve axial direction 294.2 (30.0))		294.2 (30.0)
Mounting direction		Any		

Notes: 1. For details, see the effective area on p. 206.

2. For details, see the port size on p. 206.

3. Values when air pressure is 0.5MPa (5.1kgf/cm²). For switching phase timing, add a maximum of 5 ms to the response time of AC specifications. Values in brackets [] are for G180-4E2. In addition, values for G183-4E2 are those of the all port block valve switching from neutral state.

Remark: Conversion to psi., 1MPa=145psi., 1kgf/cm²=14.2psi., e.g. 0.7MPa=102psi.

Solenoid specifications

Item	Rated voltage	DC12V		DC24V		AC100V ^{Note}		AC200V ^{Note}	
Operating voltage range	V	10.8~13.2 (12±10%)		21.6~26.4 (24±10%)		90~110 (100±10%)		180~220 (200±10%)	
Rated frequency	Hz	—		—		50	60	50	60
Current (When rated voltage is applied)	mA (r.m.s)	42		21		11		8	
Power consumption		0.5W		0.5W		1.1VA		1.6VA	
Maximum allowable leakage current	mA	1.0		1.0		1.0		1.0	
Insulation resistance	MΩ	Min. 100 (value at DC500V megger)							
Wiring and lead wire length		Grommet type: 300mm, Plug connector type: 300mm							
Color of lead wire		Red (+), Black (-)				Yellow		White	
Color of LED indicator		Red							
Surge suppression (as standard)		Flywheel diode				Bridge diode			

Notes: 1. Since the AC types have built-in bridge diodes, the starting current value and energizing current value are virtually the same.

2. For long-time continuous energizing, consult us.

3. Provide heat radiation measures to ensure that the ambient temperature (or when using a control box, the internal temperature of the box) always remains within the temperature range specifications.

Effective Area [Cv]

mm²

Basic model	Standard (single valve)	Built-in quick fitting	Remarks
G180E1 G180-4E1 G180-4E2	10.2 (0.57)	—	—
G183-4E2	9.0 (0.50)	—	—
GA180E1 GA180-4E1 GA180-4E2 GA183-4E2	8.2 (0.46)	-J4: 4.4 [0.24] -J6: 7.9 [0.44]	<ul style="list-style-type: none"> ●When mounting on a sub-base or manifold. ●Attaching TS6-02 to the sub-base P, A, B ports brings the value to 7.5.

Solenoid Valve Port Size

Basic model	Port specification		Port size
G180E1 ^{Note}	Standard	Female thread	Rc1/8
G180-4E1 G180-4E2 G183-4E2	Standard	Female thread	Rc1/8
GA180-4E1-25 GA180-4E2-25 GA183-4E2-25	1(P)	Female thread	Rc1/4
	4(A), 2(B)		
	3·5(R)		
	PR	Female thread	M5×0.8

Note: Since G180E1 is for manifold only, piping to the P port with a fitting is not possible.

Manifold Connection Port Size

Manifold model	Port	Location of piping connection	Port size
G180M□F	1(P)	Manifold	Rc1/4
	4(A), 2(B)	Valve	Rc1/8
	3·5(R)	Manifold	Rc1/4
G180M□FE	1(P)	Manifold	Rc1/4
	4(A), 2(B)	Valve	Rc1/8
	3·5(R)	Manifold	Rc1/4
	PR		M5×0.8
G180M□A	1(P)	Manifold	Rc1/4
	4(A), 2(B)		Rc1/8
	3·5(R)		Rc1/4
	PR		M5×0.8
G180M□AJ	1(P)	Manifold	Rc1/4
	4(A), 2(B)		Quick fitting for $\phi 4$ or $\phi 6$
	3·5(R)		Rc1/4
	PR		M5×0.8

Valve Mass

g

Basic model	Mass
G180E1	85
G180-4E1	80
G180-4E2	101
G183-4E2	111
GA180E1	86 (246)
GA180-4E1	85 (245)
GA180-4E2	106 (266)
GA183-4E2	115 (275)

Remark: Figures in parentheses () are the mass with sub-base: -25.

Manifold Mass

g

Manifold model	Mass calculation of each unit (n=number of units)	Block-off plate
G180M□F	$(42 \times n) + 40$	19
G180M□FE	$(60 \times n) + 70$	30
G180M□A	$(120 \times n) + 120$	
G180M□AJ	-J4: $(135 \times n) + 120$	
	-J6: $(138 \times n) + 120$	

Cylinder Operating Speed

How to obtain cylinder speed

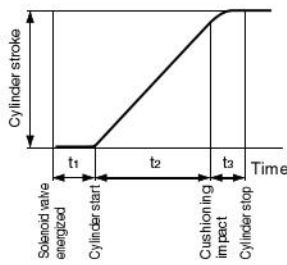

To obtain the time required for the cylinder to complete full stroke, add cylinder's delay time t_1 (time between energizing of solenoid valve and actual starting of cylinder), to the cylinder's max. operating time t_2 . When a cushion is used, add the cushioning time t_3 , to the above calculation. Standard cushioning time t_3 is approximately 0.2 seconds.

G180-4E1 G183-4E2

● Measurement conditions

- Air pressure: 0.5MPa {5.1kgf/cm²}
- Piping inner diameter and length: $\phi 6 \times 1000$ mm
- Fitting: Quick fitting TS8-01
- Load ratio = $\frac{\text{Load}}{\text{Cylinder theoretical thrust}}$ (%)
- Cylinder stroke: 150mm

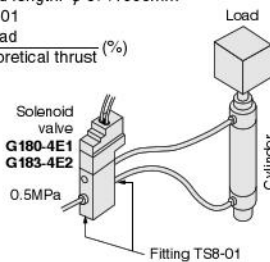

Maximum operating speed

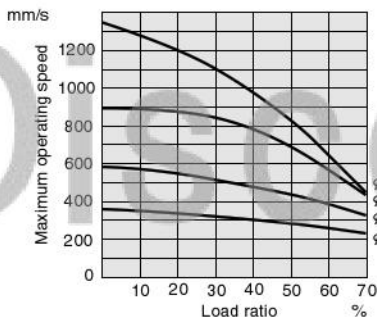

Delay time

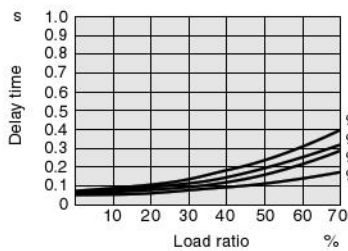

GA180-4E1-25 GA183-4E2-25

● Measurement conditions

- Air pressure: 0.5MPa {5.1kgf/cm²}
- Piping inner diameter and length: $\phi 6 \times 1000$ mm
- Fitting: Quick fitting TS8-02
- Load ratio = $\frac{\text{Load}}{\text{Cylinder theoretical thrust}}$ (%)
- Cylinder stroke: 150mm

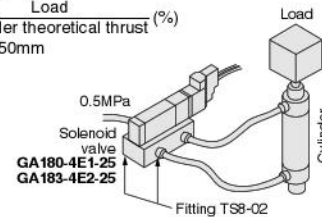

Maximum operating speed

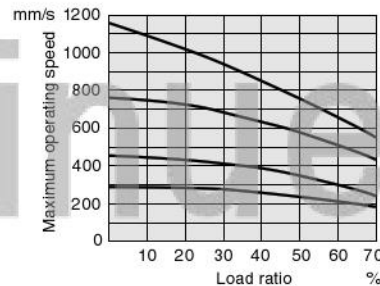

Delay time

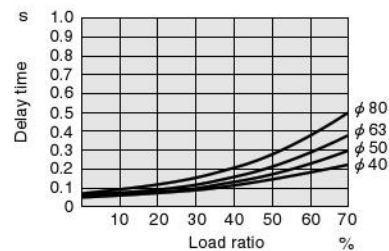

Flow Rate

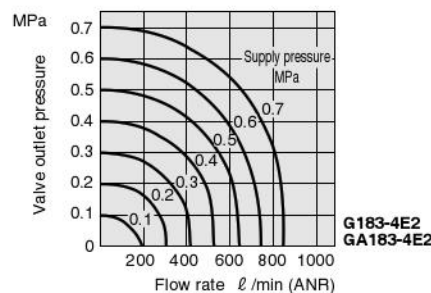
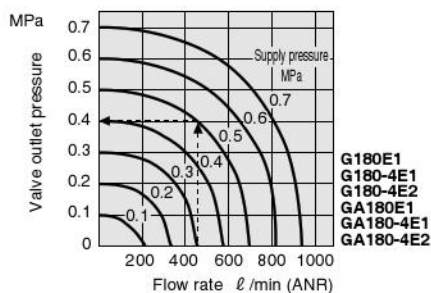

How to read the graph

If supply pressure is 0.5MPa and flow rate is 460 l/min (ANR), the valve outlet pressure becomes 0.4MPa.

G180 Series Solenoid Valve Order Code

2-, 3-port valve Number of ports		2-, 3-port valve Valve function		3-position valve Valve function		Sub-base		Manual override		Wiring		
3-port 		Normally closed (NC) 		All port block 		Without sub-base 		Non-locking type 		Grommet type with LED indicator 		
2-port 		Normally open (NO) 		ABR connection 		With sub-base 		Locking type 		Straight connector with LED indicator 		
				PAB connection 						L connector with LED indicator 		
										Voltage ^{Note 2}		
Direct piping	5-port single solenoid	G180-4E1								-81	-PSL -PLL	DC12V DC24V AC100V AC200V
	5-port double solenoid	G180-4E2										
	5-port 3-position	G183-4E2		-13, -14								
Sub-base piping	5-port single solenoid	GA180-4E1				-25				-81	-PSL -PLL	DC12V DC24V AC100V AC200V
	5-port double solenoid	GA180-4E2										
	5-port 3-position	GA183-4E2		-13, -14								
For manifold for combined mounting of 2-, 3-, 5-port valves only ^{Note 1}	2-, 3-port for G180□ F, FE	G180E1		-2 -11						-81	-PSL -PLL	DC12V DC24V AC100V AC200V
	2-, 3-port for G180□ A, AJ	GA180E1		-2 -11		-25						

Notes: 1. They cannot be used as a single unit.
2. For AC 110V~120V or AC 220V~240V specifications, consult us.

Additional Parts (Sold Separately)

Block-off plate



● G180M□F-BP
180—For G180M

F —For F type manifold
FE—For FE type manifold
A —For A type, AJ type manifold

Lead wire for common wiring

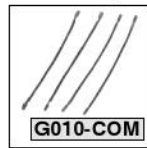

● For -PSL, -PLL
(10-piece set)

Made to Order (After the wiring order code, enter the codes below.)

Lead wire length

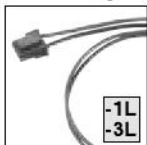

● For plug connector
● Length -1L: 1000 (mm)
-3L: 3000

G180 Series Manifold Order Code

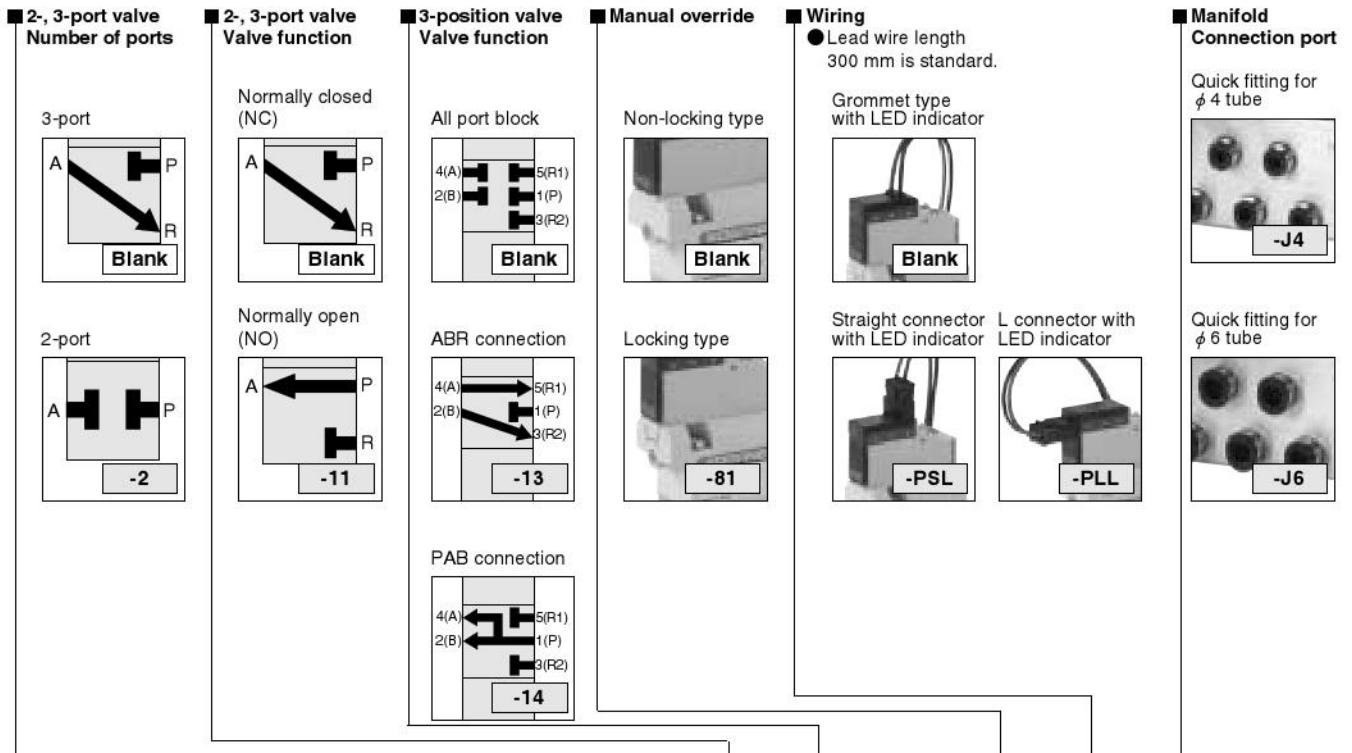

Manifold model Number of units	Station	Basic model	Valve function		Manual override	Wiring	Manifold Connection port	Voltage ^{Note}	
			NC	NO					
G180M 2 ⋮ 20	F FE	stn. <input type="checkbox"/>	-G180E1	-2	-11	-81	-PSL -PLL	DC12V DC24V AC100V AC200V	
		stn. <input type="checkbox"/>	-G180-4E1						
		stn. <input type="checkbox"/>	-G180-4E2						
		stn. <input type="checkbox"/>	-G183-4E2	-13,-14					
	A AJ	stn. <input type="checkbox"/>	-GA180E1	-2	-11	-81	-PSL -PLL	-J4 -J6	DC12V DC24V AC100V AC200V
		stn. <input type="checkbox"/>	-GA180-4E1						
		stn. <input type="checkbox"/>	-GA180-4E2	-13					
		stn. <input type="checkbox"/>	-GA183-4E2	-14					

Note: For AC 110V~120V or AC 220V~240V specifications, consult us.

- Specify the valve type for each station.
- Enter **-BP** when closing a station with a block-off plate without mounting a valve.
- For the AJ type manifold only.
- Valve mounting location from the left-hand side when facing A, B port.

Operating Principle and Symbol

3-port

Normally closed (NC)

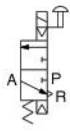

G180E1
De-energized

Normally open (NO)

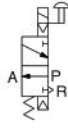

G180E1-11
De-energized

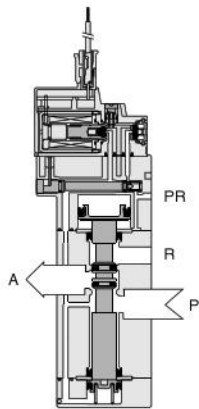
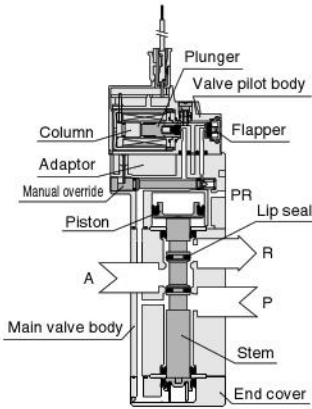

5-port, 2-position

Single solenoid

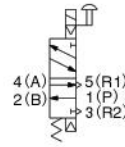

G180-4E1

Double solenoid

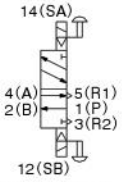

G180-4E2
(De-energized condition after energizing solenoid SA)

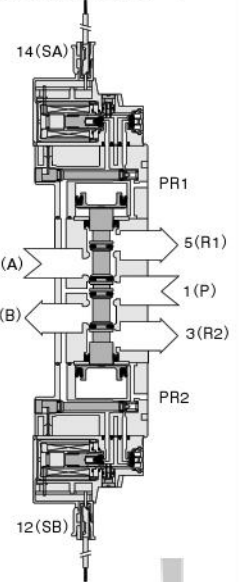
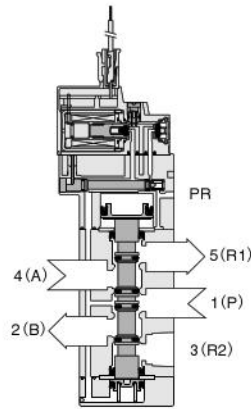

5-port, 3-position

All port block

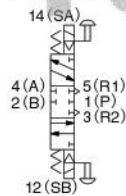

G183-4E2

ABR connection

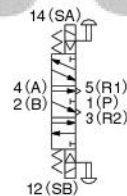

G183-4E2-13

PAB connection

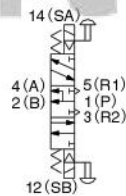

G183-4E2-14

(Both solenoid SA and SB are de-energized)

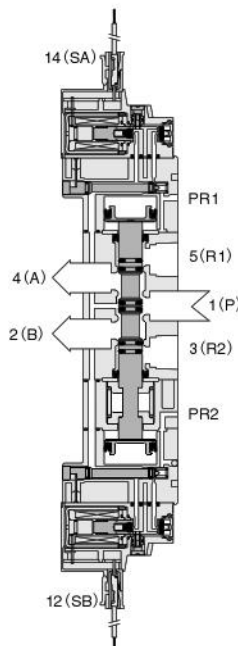
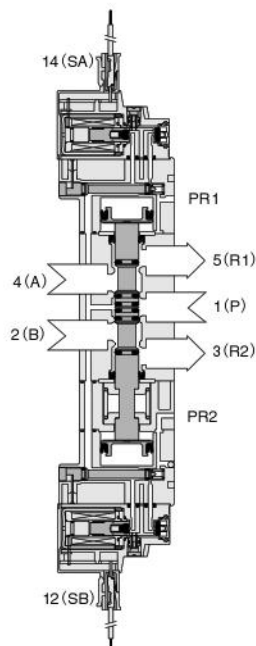
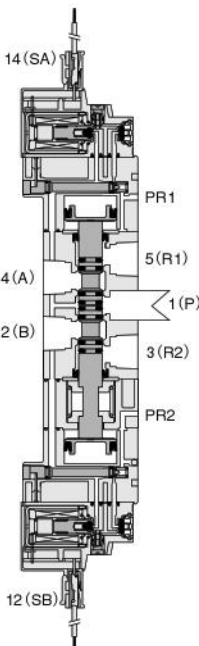

Major Parts and Materials

Parts		Materials
Valve (main valve)	Body	Aluminum alloy (anodized)
	Stem	(anodized)
	Lip seal	Synthetic rubber
	Sub-base	Aluminum alloy (anodized)
	End cover	Plastic
Valve (pilot)	Body	Plastic
	Plunger	Magnetic stainless
	Column	Magnetic stainless
Manifold	Flapper	Synthetic rubber
	Body	Aluminum alloy (anodized)
	Block-off plate	Steel (nickel plated)
	Seal	Synthetic rubber

Dimensions of Solenoid Valve 5-port , 2-, 3-position (Scale 1/3, Unit mm)

G180-4E1-PSL  G180_4E1

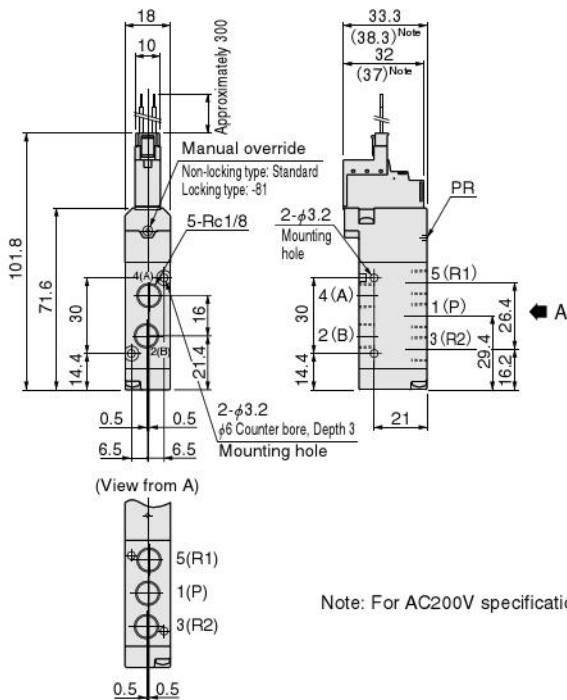

GA180E1-25-PSL **GA180-4E1-25-PSL**  GA180E1

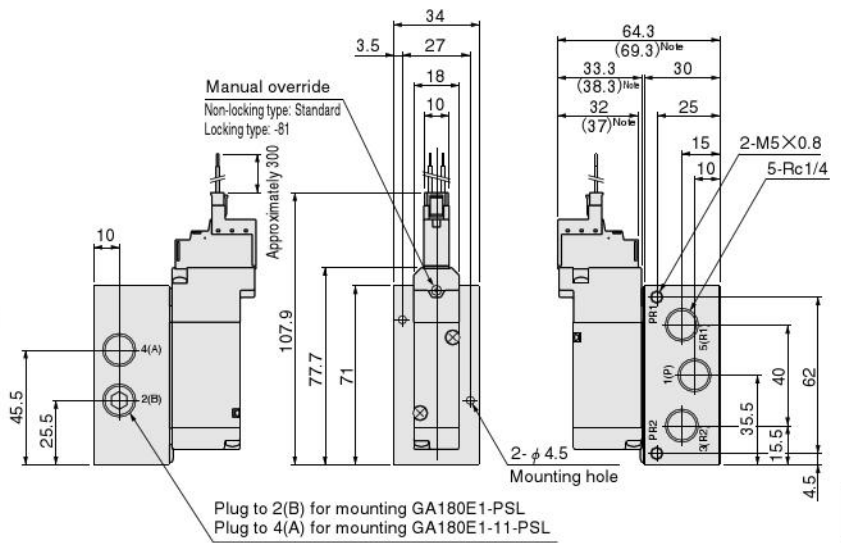

G180-4E2-PSL  G180_4E2

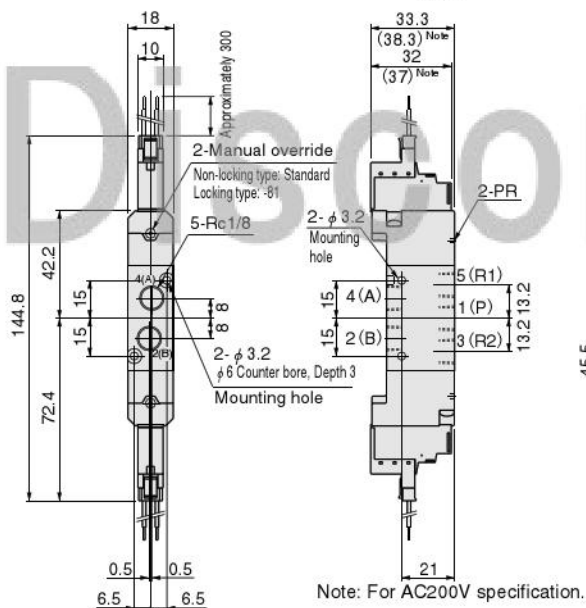

GA180-4E2-25-PSL  GA180_4E

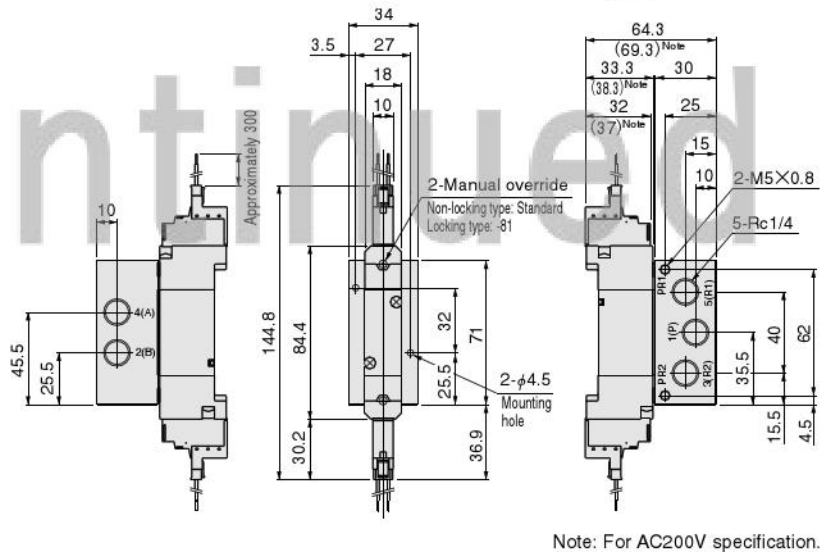

G183-4E2-PSL  G183_4E2

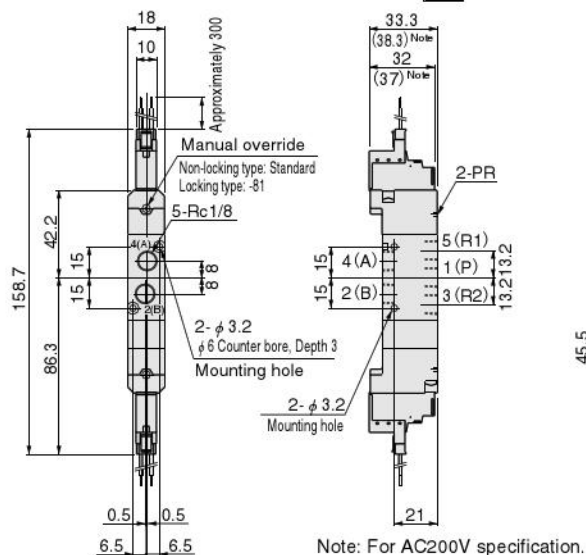

GA183-4E2-25-PSL  GA183_4E

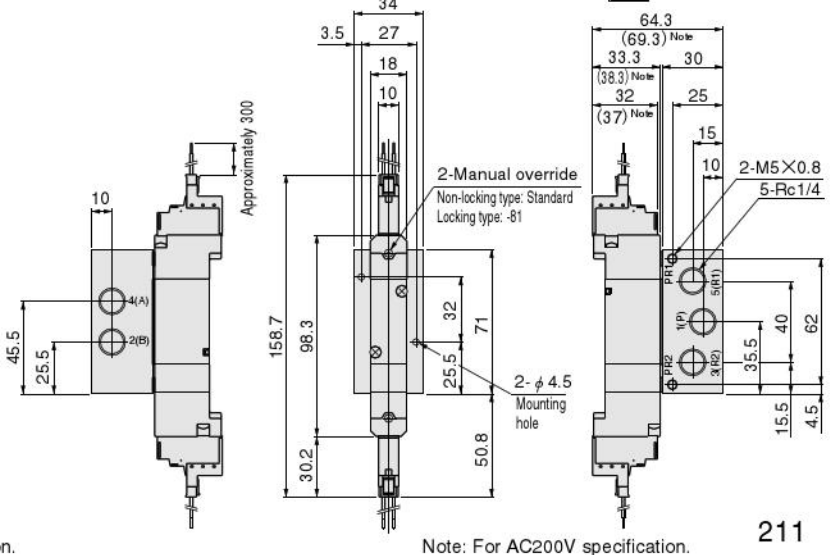

G180M□A

CAD G180MA

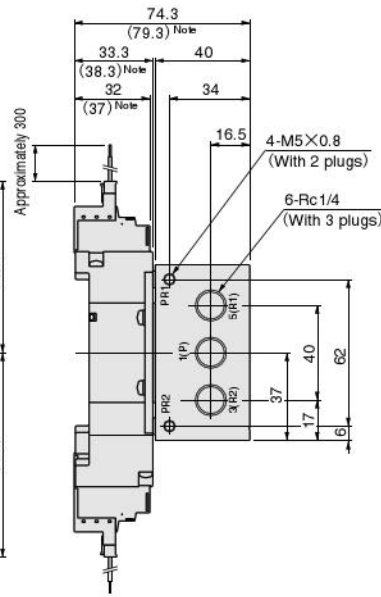
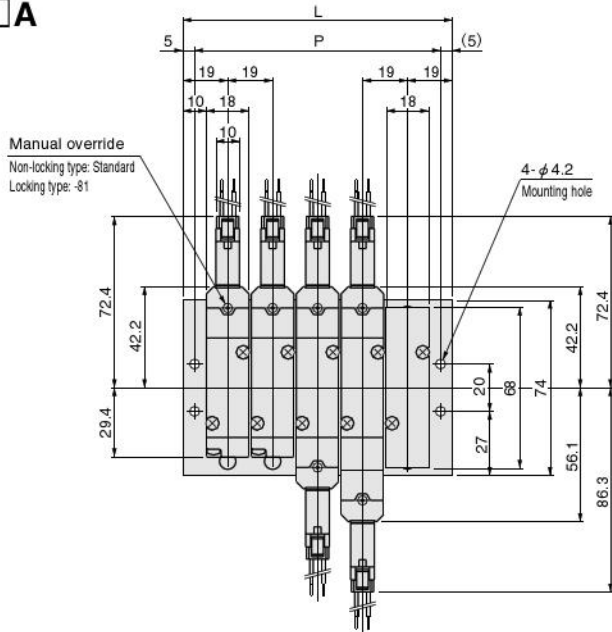

Unit dimensions

Number of units	L	P
2	57	47
3	76	66
4	95	85
5	114	104
6	133	123
7	152	142
8	171	161
9	190	180
10	209	199
11	228	218
12	247	237
13	266	256
14	285	275
15	304	294
16	323	313
17	342	332
18	361	351
19	380	370
20	399	389

Note: For AC200V specification.

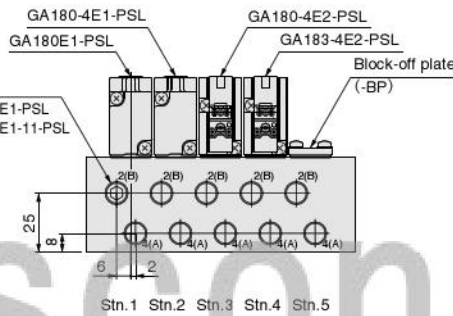

Discontinued

G180M□AJ

CAD G180MAJ

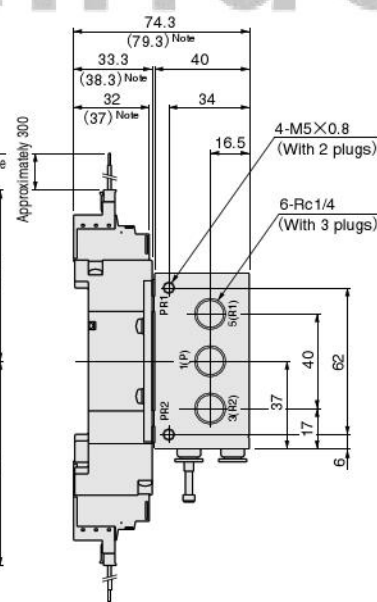
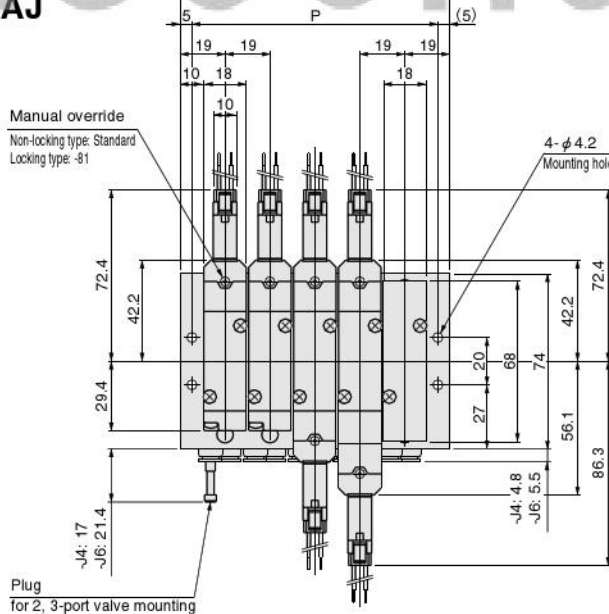

Unit dimensions

Number of units	L	P
2	57	47
3	76	66
4	95	85
5	114	104
6	133	123
7	152	142
8	171	161
9	190	180
10	209	199
11	228	218
12	247	237
13	266	256
14	285	275
15	304	294
16	323	313
17	342	332
18	361	351
19	380	370
20	399	389

Note: For AC200V specification.

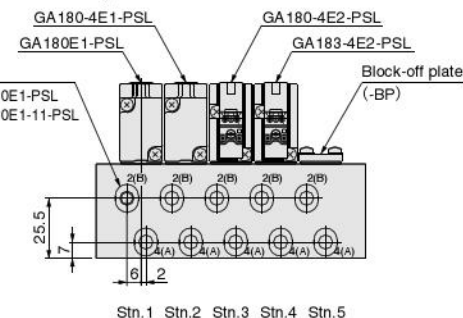

For wiring specifications, see p. 214.

■ For DC12V, 24V, AC100V

● Grommet: Blank

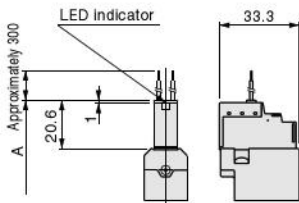

● Solenoid with straight connector: -PSL

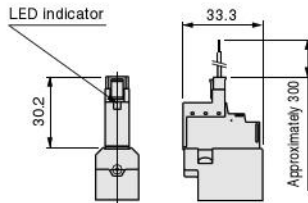

● Solenoid with L connector: -PLL

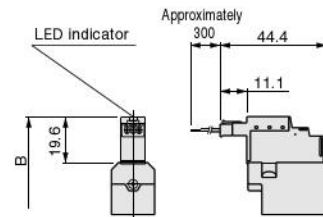

■ For AC200V

● Grommet: Blank

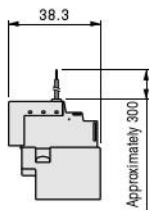

● Solenoid with straight connector: -PSL

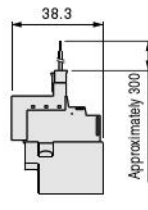

● Solenoid with L connector: -PLL

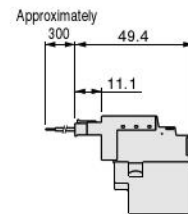

mm

Model	Code	A	B	Remarks
G180E1, G180-4E1		92.2	91.2	Length to the end of the valve or sub-base
GA180E1-25, GA180-4E1-25		98.3	97.3	
G180-4E2, GA180-4E2-25		125.6	123.6	Total length to the end of the opposite solenoid
G183-4E2, GA183-4E2-25		139.5	137.5	

Discontinued