

Multi-channel Flow Rate Sensor Controllers

The Flow rate sensor detects workpieces lifted by vacuum that could not be detected by the pressure sensor.

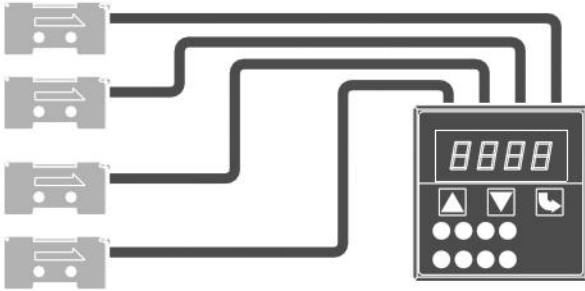

A single controller detects four points at the same time



Connectable to a personal computer

- Use a PC to perform flow rate setting, capture of flow rate value, and reference flow rate setting.



Three types of sensor heads, depending on flow rate range

- Three types are available, including
 - 500~500 ml/min (ANR), [–30.5~30.5 in.³/min.]
 - 3~3 l/min (ANR), [–0.11~0.11 ft.³/min.]
 - and 0~10 l/min (ANR), [0~0.35 ft.³/min.].



Not affected by piping resistance

- Since the flow rate sensor head is not affected by piping resistance, there is no restriction on mounting position.

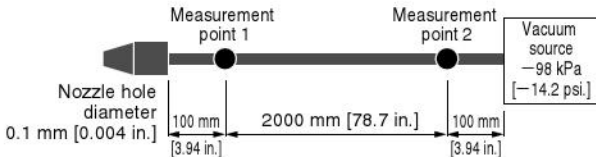

Measurement results using $\phi 1.8$ [0.071 in.] tube

	Measurement point 1	Measurement point 2
Flow rate sensor	0.11 l/min [0.0039 ft. ³ /min.]	0.12 l/min [0.0042 ft. ³ /min.]
Pressure sensor	-78 kPa [-11.3 psi.]	-95 kPa [-13.8 psi.]

※ Based on Koganei test standard.

Output Mode

Window comparator mode 1

- Mode for freely setting L1 and L2. Note, however, that switch output does not go ON while flow rate is increasing.

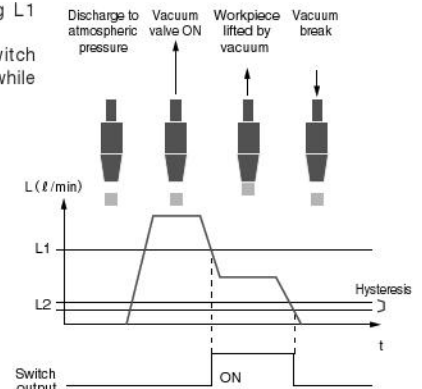

Window comparator mode 2 and 3

- Modes for automatically setting L1, using ΔL setting and reference flow rate capture. (L1 = Reference flow rate - ΔL)

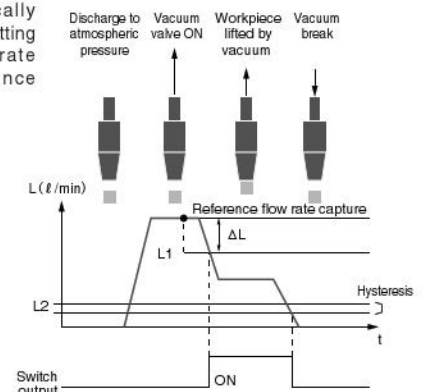

Window comparator mode 2

- When L1 has been set, this mode maintains it unchanged until reference flow rate capture is performed again.

Window comparator mode 3

- Each time the L1 setting is deleted when switch output goes OFF, this mode performs reference flow rate capture and sets L1. Effective for situations where flow rate fluctuation is severe. When using window comparator mode 3, use RS232C to perform reference flow rate capture from outside.

Window comparator mode 4

- Mode for freely setting L1 and L2.

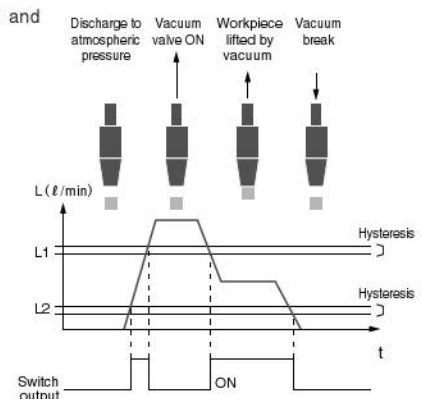

DANGER

- While the product is in operation, do not attempt to adjust the attached mechanisms (connecting and disconnecting the wiring connector, or attach or position the sensor head, etc.). Abnormal operations could result in injury.

WARNING

- While the Multi-channel Flow Rate Sensor Controller is in operation, do not apply an external magnetic field to the controller and sensor head. This could cause unintentional operation leading to damage to equipment or to personal injury.
- When wiring, be careful to ensure that the wiring polarity is correct.
A wrong polarity could result in damage to the Multi-channel Flow Rate Sensor controller.

CAUTION

- Always use the specified sensor head with this product.
Use of an unspecified item could result in erratic operation.
- When handling the Multi-channel Flow Rate Sensor Controller and sensor head, avoid hitting, dropping, or bumping with excessive force (490 m/s² [50 G] or more). Even if not apparently damaged, the internal parts could be damaged, leading to erratic operation.
- Do not short the load.
Switching on sensor output with a shorted load could cause damage to the Multi-channel Flow Rate Sensor Controller due to overcurrent.
Example of load shorting: Connecting the output lead wires for sensor output directly to the power supply.
- When mounting the fitting to the sensor head, the tightening torque should not exceed 2.5 N·m [1.84 ft·lbf]. In addition, when securing the sensor head, use an M3 screw and the tightening torque should not exceed 0.6 N·m [0.44 ft·lbf]. Excessive tightening could damage the sensor head, etc.
Always switch off the power before connecting the sensor head and controller. Attempting to connect the sensor head with the power on could cause erratic operation in the controller due to surge voltage, etc.



General precautions

Wiring

1. If power is supplied from a commercial switching regulator, ensure that the frame ground (F.G.) terminal of the power supply is connected to an actual ground.
2. In the case of noise generating equipment (switching regulator, inverter motor, etc.) being used in the vicinity of sensor mounting portion, connect the frame ground (F.G.) terminal of the equipment to an actual ground.
3. When wiring is completed, check that there is no error in the wiring connections.

Others

1. Sensor head is designed for use with non-corrosive gas. It cannot be used for liquid or corrosive gas.
2. Use within the rated voltage range for power supply.
3. Do not use during the initial transient time (0.5 sec.) after the power supply is switched on.
4. Do not operate the keys with pointed or sharp objects.
5. When using window comparator mode 2 in operations that capture repeated utilization of the reference flow rate, the guaranteed number of times may be exceeded in a short period of time. In such cases, use window comparator mode 3.
6. If using with window comparator mode 3, use FSU-S-D.

Handling Instructions and Precautions



Mounting and wiring

Sensor head and connector connection procedure

When the sensor head FSU-□-□ is supplied, the sensor head body and mini clamp connector (male) are not yet connected. Follow the procedure below to perform the connection.

1. Check that the connector cover (the part where lead wires are to be inserted) is protruding from the connector body.

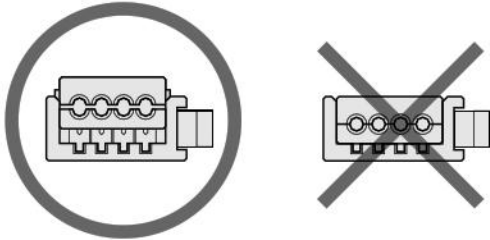

It cannot be used if it's flat and placed at the same level against the body.

2. Cut the cable at the length required for the sensor head. Strip off the cable sheath for 50 mm [1.97 in.] from the cable end, and expose the lead wires. At this time, do not take off the lead wire insulation.

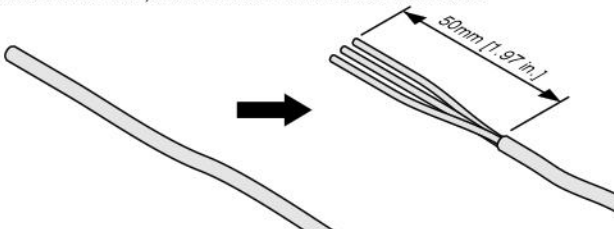

3. Follow the instructions in the table below to insert the lead wires into the hole in the connector cover. Look through the top of the semi-transparent cover to check that the lead wires have been firmly inserted all the way to the back. (Insertion length is about 9 mm [0.35 in.])

Use caution in making the connections, since switching on the power with wrong connections will damage the sensor head and controller.

No. on the connector	Signal name	Color of lead wire
1	Sensor head power supply (+)	Sensor head brown wire
2	Sensor head voltage output	Sensor head black wire
3	Sensor head power supply (0V)	Sensor head blue wire
4	Reference flow rate capture	Prepared by customer AWG 24-26 (0.14-0.3sq) Insulation diameter: φ 0.8~1.0 mm [0.031~0.039 in.]

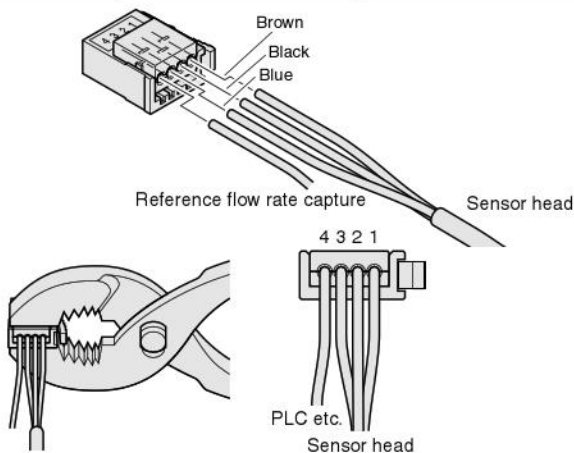

4. Taking care to avoid letting the lead wires slip out from the connector, use pliers or some other hand tool to crimp the cover and connector body, and push the cover into the connector body. Limit the crimping force to 980.7 N [220.5 lbf.]. When the cover is flat and placed at the same level against the connector body, the connection is complete.
5. In the same way, handle the sensor head relay cable PSUK-□ mini-clamp connectors (male, female).
6. Check one more time that the wiring is correct.

7. On the sensor head body, connect the sensor head-side connector. Open the sensor head cover, connect the connector, and then close the cover.

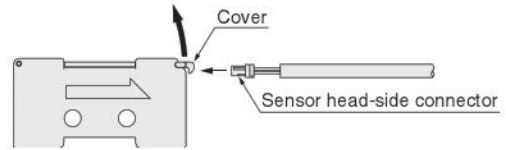

Attaching and removing of the sensor head, and the power supply, switch, and communication cable

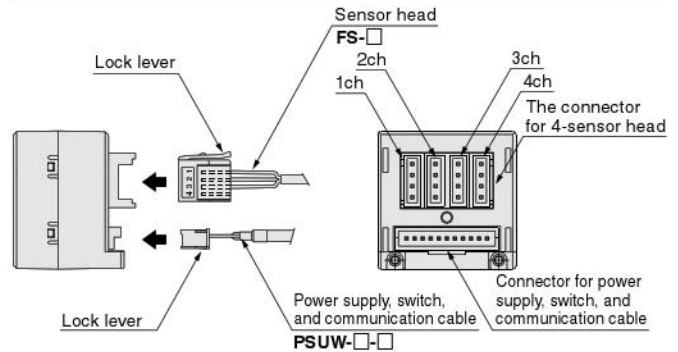

To mount the sensor head and the power supply, switch, and communication cable, align the lock lever position as shown in the figure, and push until the lock hooks on the controller-side connector.

To remove, push down completely on the lock lever, take the connector and pull it out. At this time, be careful to avoid applying excessive force on the lead wires.

Attaching the panel mounting parts and protective front cover

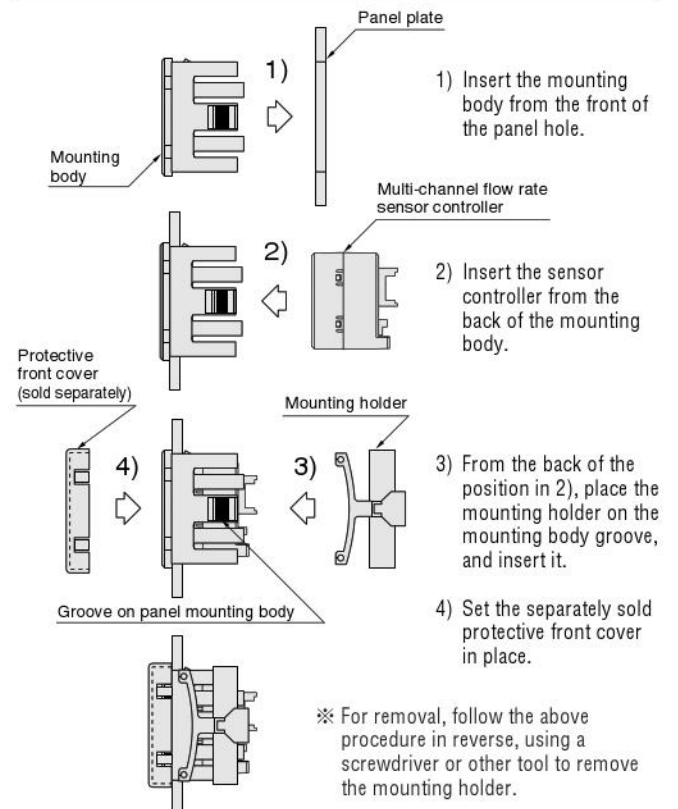

Attaching the mounting bracket

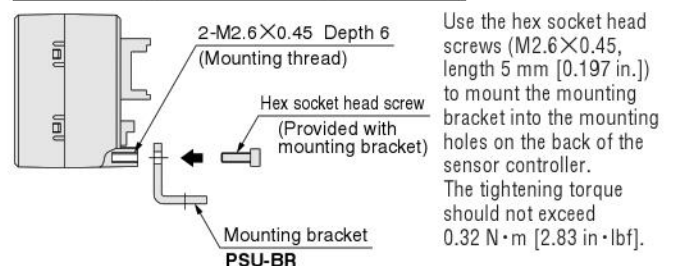

Setting procedure

⚠ Caution

1. Since miswiring in the sensor head, or in the power supply, switch, and communication cable, can damage both the controller and sensor head, always check the wiring before switching on the power.
2. The setting conditions are written to EEPROM and saved. Be aware that EEPROM has a finite lifetime, with guaranteed number of times up to 100,000 times.
3. When using window comparator mode 2 in operations that involve repeated reference flow rate capture, the EEPROM guaranteed number of times may be exceeded in a short period of time. In such cases, use window comparator mode 3.
4. In this catalog, window comparator mode 1 is called by code: CO1, window comparator mode 2 by code: CO2, window comparator mode 3 by code: CO3, and window comparator mode 4 by code: CO4.

■ Major parts and functions

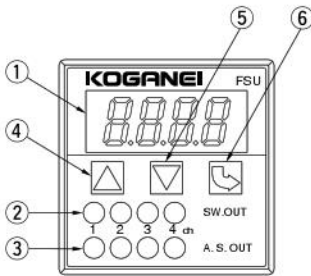

Figure 1

No.	Name	Description
①	LED display (red)	Displays the detected flow rate value, setting contents, and error content
②	Switch output indicator (red)	Lights up when switch output is ON
③	Autoscan indicator (green)	The channel whose current flow rate is displayed on the LED lights up
④	UP key (▲)	Used when adjusting set value upward
⑤	DOWN key (▼)	Used when adjusting set value downward
⑥	Mode key (⏏)	Used for all types of settings

■ Setting preparation

- Connect the connectors to the sensor heads.
(See p.801 for the connection procedure for the sensor head connectors.)
- Connect the sensor heads (one to four pcs.) and the power supply, switch, and communication cable to the controller. (See p.801 for attaching and removing of the sensor head and the power supply, switch, and communication cable.)

■ Setting procedure

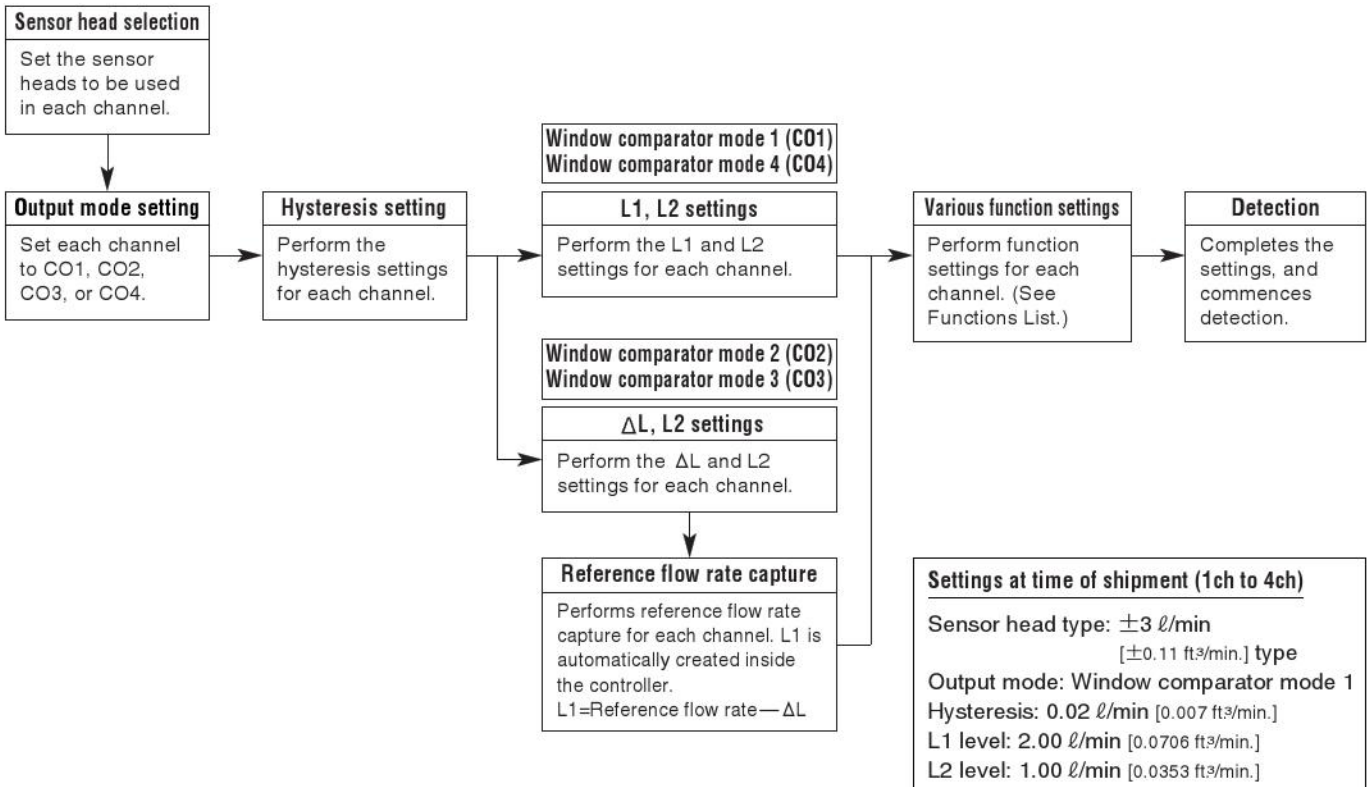

Setting Procedure

Setting

Reference flow rate capture method in window comparator mode 2 and 3

Device key operation method	For the operations method, see p.804
RS232C method	For RS232C commands, see p.806
General-purpose I/O input method	See diagram below

Reference flow rate capture method using general-purpose I/O input

Set PIN (sensor head connector 4-pin) for corresponding channel to "L level" (0.5V or less, 10 ms or longer).

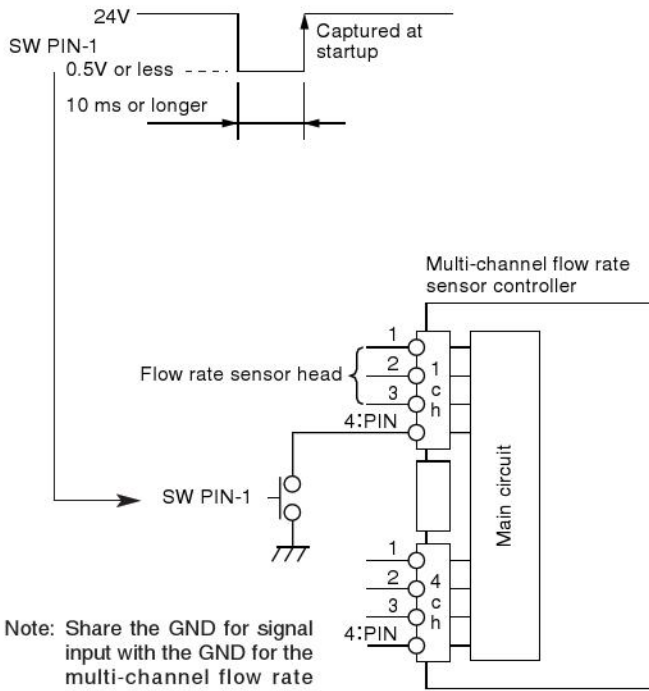

If not using general-purpose I/O input to perform reference flow rate capture, do not connect anything to the PIN. (Note: PIN is pulled up at 24V.)

Functions List (For details about operations, see the each operation method)

Function	Device button command	Serial communication command (-D only)
Flow rate display	○	@A
L1 (ΔL)/L2 point settings	○	@PRE
Hysteresis setting	○	@HYS
Reference flow rate capture	○	@P
Mode selection	○	@MODE
Sensor head type setting	○	@TYPE
Zero reset	○	@B
Flow rate display autoscan	○	@AS
Switch output reversal (Enabled in mode 4 only)	○	@INV
Peak hold	○	@PHL
Bottom hold	○	@BHL
Flow rate display deleted	○	@DIS
Output mode check	×	@MD
Sensor head type check	×	@TP
ON (ΔL)/OFF point check	×	@C
Reference flow rate, ΔL/OFF point check	×	@E (Enabled for modes 2 and 3 only)
Switch output condition display	×	@SW
Version display	×	@VER

Detection mode

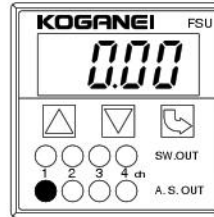

Figure 2

- Switching on the power supply (DC24V voltage) automatically provides detection mode.
- The flow rate of the selected channel is indicated in the LED display. (The selected channel's A.S.OUT LED (green) lights up. See Figure 2.)
- The SW.OUT LED (red) lights up when the switch output is turned ON.
- Pressing the key or key changes the selected channel.
- If the display appears, it means that the selected channel's sensor head was not connected or has a wire break.
- In the case of a wire break, shut off the power and replace the sensor head.

Sensor head selection

Use the following procedure to perform settings for the sensor head used in each channel.

Procedure	Device operation	7-seg display	Remark
1		SE1	
2		SE	
3	(Push both at the same time)	CH1	Use or to select channel
4		SE1	Use or to select sensor head
5			Sensor head determined

Note: SE2 and SE4 cannot be used.

[Sensor head selection]

SE1: -3.00 to 3.00: $\pm 3\ell$ [± 0.11 ft.³] type

SE2: Cannot be used

SE3: -500 to 500: ± 500 [± 30.5 in.³] mℓ type

SE4: Cannot be used

SE5: 0.00 to 10.00: 10ℓ [± 0.35 ft.³] type

Output mode selection

Use the following procedure to perform output mode settings for each channel.

Procedure	Device operation	7-seg display	Remark
1		SE1	
2		SE	
3	(Push both at the same time)	CO1	Use or to select channel
4		CO1	Use or to select output mode
5			Output mode determined

[Output mode selection]

CO1: Window comparator mode 1

CO2: Window comparator mode 2

CO3: Window comparator mode 3

CO4: Window comparator mode 4

Hysteresis setting

Use the following procedure to change the hysteresis for each channel.

Procedure	Device operation	7-seg display	Remark
1		SEF 1	
2		SEF 2	
3		SEF	
4	(Push both at the same time)	HYS 1	Use or to select channel
		0002	Use or to perform hysteresis setting
5			Hysteresis determined

[Hysteresis selection]

HYS1: 1ch
HYS2: 2ch
HYS3: 3ch
HYS4: 4ch

- To prevent chattering, set hysteresis to 2 digits or more.

Threshold value setting (L1 (ΔL)/L2 setting)

Use the following procedure to perform threshold value settings for each channel.

Procedure	Device operation	7-seg display	Remark
1		SEF 1	
2		SEF	
3		11	Use or to select channel
4		***	Use or to set threshold value
5			Threshold value determined

[Threshold value setting]

11: 1ch_L1/ΔL
12: 1ch_L2
21: 2ch_L1/ΔL
22: 2ch_L2
31: 3ch_L1/ΔL
32: 3ch_L2
41: 4ch_L1/ΔL
42: 4ch_L2

Reference flow rate capture (for window comparator mode 2 and 3)

When using window comparator mode 2 or 3, use the following procedure to perform reference flow rate capture.

Procedure	Device operation	7-seg display	Remark
1		SEF 1	
2		SEF	
3	(Push both at the same time)	REF 1	Use or to select channel
4			Reference flow rate captured

[Reference flow rate capture]

REF1: 1ch
REF2: 2ch
REF3: 3ch
REF4: 4ch

Flow rate display switch-off

Use the following procedure to switch off the flow rate display.

Procedure	Device operation	7-seg display	Remark
1		SEF 1	
2		SEF 2	
3		SEF	
4	(Push both at the same time)		7-seg LED off
5	(Push both at the same time)	***	7-seg LED re-lighted

Flow rate display autoscan

Use the following procedure to switch the flow rate display to autoscan mode.

Since autoscan mode is combined with the key lock function, no key operation other than cancellation of autoscan can be performed.

Procedure	Device operation	7-seg display	Remark
1		SEF 1	
2		SEF 2	
3		SEF	
4	(Push both at the same time)		Autoscan start
5	(Push both at the same time)		Autoscan stop

Note: Autoscan mode is cancelled when the power supply is switched OFF.

Switch output reversal (enabled for window comparator mode 4 only)

Use the following procedure to reverse the switch output for each channel.

Procedure	Device operation	7-seg display	Remark
1		SEF 1	
2		SEF 2	
3		SEF 3	
		SEF	
4	(Push both at the same time)	CH 1	Use or to select channel
		S-0	Use or to set
5			Output mode determined

Note: Cannot be used with any mode other than window comparator mode 4.

[Switch output reversal]

S-0: Not reversed (A-contact)
S-1: Reversed (B-contact)

Setting procedure

Zero point correction (Zero reset)

Use the following procedure to perform zero point correction for each channel.

Procedure	Device operation	7-seg display	Remark
1		SEF 1	
2		SEF 2	
3		SEF 3	
4		SEF	
5	(Push both at the same time)	b-1	Use or to select channel
6			Zero point correction

Note: Zero point is cancelled when the power supply is switched OFF.

[Zero point correction]

b-1: 1ch

b-2: 2ch

b-3: 3ch

b-4: 4ch

Peak hold and bottom hold

Use the following procedure to put the flow rate display on peak hold or bottom hold. The display channel can be switched back and forth while in the hold position.

Procedure	Peak hold	7-seg display	Bottom hold	7-seg display	Remark
1		SEF 1		SEF 1	
2		SEF 2		SEF 2	
3		SEF 3		SEF 3	
4		SEF 4		SEF 4	
5		SEF		SEF	
6	(Push both at the same time)	PHL	(Push both at the same time)	bHL	Hold start
7	(Push both at the same time)		(Push both at the same time)		Hold cancel

Note: Peak hold and bottom hold are cancelled when the power supply is switched OFF.
Peak hold and bottom hold cannot be implemented at the same time.

Error Display

Error display	Error description	Error cancel
oFF	Sensor head on selected channel either not connected or has a wire break.	In the case of a wire break, shut off the power and replace the sensor head.
E-1	In window comparator mode 2 and 3, threshold is set outside the measured range.	Correct the error, and then press the mode key for at least 1 second.
E-2 n (n is the targeted channel)	Overvoltage (5V or more) applied to sensor input (AN0 to AN3).	
E-3 n (n is the targeted channel)	Overcurrent flowing to switch output.	

Communication

Communication with personal computer

● Hardware and operations environment

PC: PC-98 series (excluding PC-98LT) or equivalent DOS/V machine
OS: Windows95 or later

● Software and operations environment

Hyperterminal with Windows95 or later as the standard.
※Windows is a registered trademark of Microsoft Corp.

● Communication parameter

Baud rate	9600 (baud)
Stop bit length	1 [bit]
Parity	Odd
Parity check	Yes
Data bit length	8 [bit]
Communication method	Full duplex
Return key send procedure	CR code, LF code

● Communication cable specification and connection

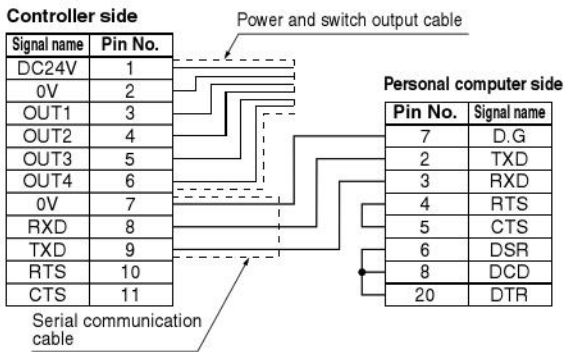

D-sub 25 pin configuration

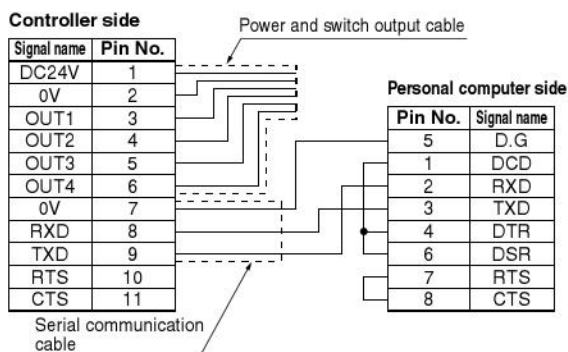

D-sub 9 pin configuration

● Communication command detail

Command List Note: " " denotes a space.

@A

Function: Reads out the current flow rate value (1ch-4ch).

Send example: @A c/r/f

Response example: 1 = -3.00 c/r/f
2 = -3.00 c/r/f
c/r/f ← When sensor head is not connected
4 = 0.00 c/r/f
c/r/f

Response example: NG c/r/f

21: illegal type

@PRE

Function: Sets the ON and OFF points for each channel.

Send example: @PRE11_ -3.00 c/r/f

Response example: OK c/r/f

Response example: NG c/r/f

21: illegal type

@PRE11: Sets L1/ΔL for Channel 1

@PRE12: Sets L2 for Channel 1

@PRE21: Sets L1/ΔL for Channel 2

@PRE22: Sets L2 for Channel 2

@PRE31: Sets L1/ΔL for Channel 3

@PRE32: Sets L2 for Channel 3

@PRE41: Sets L1/ΔL for Channel 4

@PRE42: Sets L2 for Channel 4

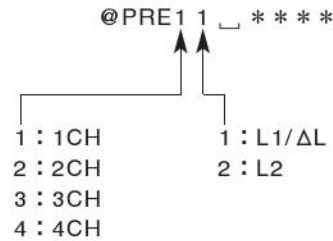

@HYS

Function: Sets the hysteresis width for each channel.

Send example: @HYS11_0.02 c/r/f

Response example: OK c/r/f

Response example: NG c/r/f

21: illegal type

@HYS11: Hysteresis width setting for Channel 1

@HYS21: Hysteresis width setting for Channel 2

@HYS31: Hysteresis width setting for Channel 3

@HYS41: Hysteresis width setting for Channel 4

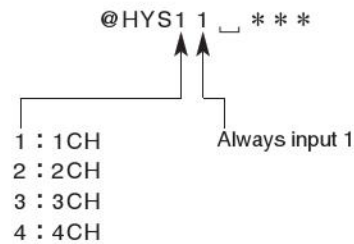

@P

Function: In output mode, the reference flow rate capture when comparator modes 2 and 3 are selected.

Send example: @P c/r/f
 Response example: OK c/r/f
 Response example: NG c/r/f
 21: illegal type

@P1: Channel 1 reference value setting
 @P2: Channel 2 reference value setting
 @P3: Channel 3 reference value setting
 @P4: Channel 4 reference value setting

@P1
 ↑
 1 : 1CH
 2 : 2CH
 3 : 3CH
 4 : 4CH

@MODE

Function: Sets the output mode for each channel.

Send example: @MODE1_1c/r/f
 Response example: OK c/r/f
 Response example: NG c/r/f
 21: illegal type

@MODE1_1
 ↑ ↑
 1 : 1CH 1: Window comparator mode 1
 2 : 2CH 2: Window comparator mode 2
 3 : 3CH 3: Window comparator mode 3
 4 : 4CH 4: Window comparator mode 4

@TYPE

Function: Sets the sensor head type for each channel.

Send example: @TYPE1_1c/r/f
 Response example: OK c/r/f
 Response example: NG c/r/f
 21: illegal type

@TYPE1_1
 ↑ ↑
 1 : 1CH 1: -3.00~3.00
 2 : 2CH 2: Cannot be used
 3 : 3CH 3: -500~500
 4 : 4CH 4: Cannot be used
 5: 0.00~10.00

@INV (Enabled for window comparator mode 4 only)

Function: Sets switch output reversed/not reversed.

Send example: @INV1_0c/r/f
 Response example: OK c/r/f
 Response example: NG c/r/f
 21: illegal type

@INV1_0
 ↑ ↑
 1 : 1CH 0: Not reversed
 2 : 2CH 1: Reversed
 3 : 3CH
 4 : 4CH

@B

Function: Performs zero correction for each channel.

Send example: @B1 c/r/f
 Response example: OK c/r/f
 Response example: NG c/r/f
 21: illegal type

@B1
 ↑
 1 : 1CH
 2 : 2CH
 3 : 3CH
 4 : 4CH

@SW

Function: Displays the switch output for each channel.

Send example: @SW c/r/f
 Response example: 1010 c/r/f
 Response example: NG c/r/f
 21: illegal type

1 0 1 0
 ↑ ↑ ↑ ↑
 1 2 3 4
 ch ch ch ch

1: Switch output ON
 0: Switch output OFF

@MD

Function: Displays the output mode for each channel.

Send example: @MD c/r/f
 Response example: 1231 c/r/f
 Response example: NG c/r/f
 21: illegal type

1 2 3 1
 ↑ ↑ ↑ ↑
 1 2 3 4
 ch ch ch ch

1: Window comparator mode 1
 2: Window comparator mode 2
 3: Window comparator mode 3
 4: Window comparator mode 4

@TP

Function: Displays the sensor head type for each channel.

Send example: @TP c/r/f
 Response example: 1135 c/r/f
 Response example: NG c/r/f
 21: illegal type

1 1 3 5
 ↑ ↑ ↑ ↑
 1 2 3 4
 ch ch ch ch

1: -3.00~3.00
 2: Cannot be used
 3: -500~500
 4: Cannot be used
 5: 0.00~10.00

@C

Function: Displays the L1 (ΔL) and L2 points for each channel.

Send example: @C1 c/r/f
 Response example: 1.00 c/r/f ←L1 (ΔL)
 0.50 c/r/f ←L2
 c/r/f
 Response example: NG c/r/f
 21: illegal type

@C1
 ↑
 1 : 1CH
 2 : 2CH
 3 : 3CH
 4 : 4CH

@E
 Function: Displays L1 = Reference flow rate— ΔL , and L2 for each channel.
 Send example: @E1 c/r/f
 Response example: 1.00 c/r/f ←L1 = Reference flow rate— ΔL
 0.50 c/r/f ←L2
 c/r/f
 Response example: NG c/r/f
 21: illegal type

@E1
 ↑
 1 : 1CH
 2 : 2CH
 3 : 3CH
 4 : 4CH

@DIS
 Function: Switches off (Locks) the main unit LED.
 Send example: @DIS_1 c/r/f @DIS_1
 Response example: OK c/r/f
 Response example: NG c/r/f
 21: illegal type

@DIS_1
 ↑
 1: Not lighted
 0: Lighted

@AS
 Function: Sets ON/OFF for autoscan function.
 Send example: @AS_1 c/r/f @AS_1
 Response example: OK c/r/f
 Response example: NG c/r/f
 21: illegal type

@AS_1
 ↑
 1 : ON
 0 : OFF

@PHL
 Function: Sets ON/OFF for peak hold function.
 Send example: @PHL_1 c/r/f @PHL_1
 Response example: OK c/r/f
 Response example: NG c/r/f
 21: illegal type

@PHL_1
 ↑
 1 : ON
 0 : OFF

@BHL
 Function: Sets ON/OFF for bottom hold function.
 Send example: @BHL_1 c/r/f @BHL_1
 Response example: OK c/r/f
 Response example: NG c/r/f
 21: illegal type

@BHL_1
 ↑
 1 : ON
 0 : OFF

For sending @A

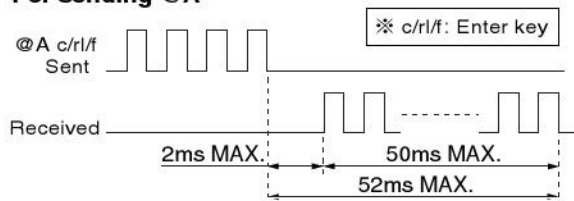

For sending @P, @PRE, @MODE

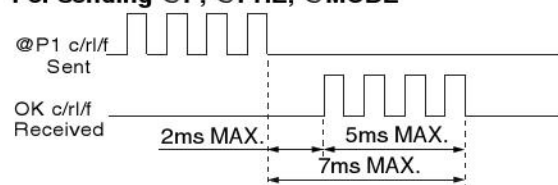

Communication

● Hyperterminal setting method

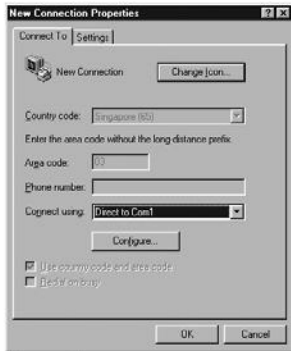

Figure 1

Click **File**, and then click **Property** to open the window at left, and set **Connect To**.

Click on **Configure...**

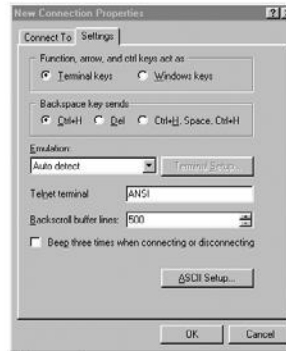

Figure 3

Clicking on the tag of the **Settings** in Figure 1 displays Figure 3. Click the **ASCII Setup...** button.



Figure 2

As shown in Figure 2, set the baud rate, etc.

Bits per second : 9600
 Data bits : 8
 Parity : Odd
 Stop bits : 1
 Flow control : Xon/Xoff

When the settings are complete, click **OK**.

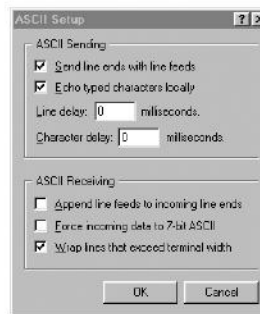
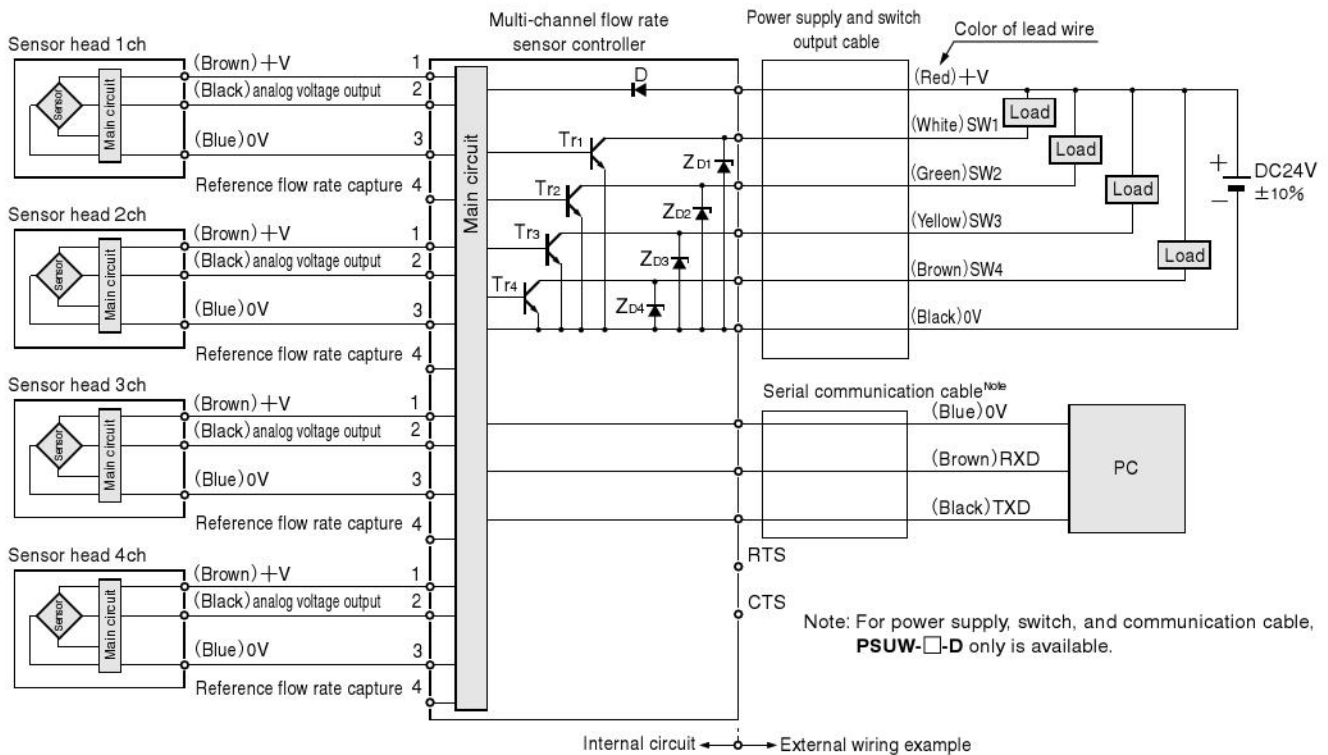

Figure 4

Set as shown in Figure 4, and click **OK**.

Return to Figure 3. Click **OK** again.

Internal Circuit Diagram and Wiring Specifications (External Wiring Example)



Note: Be aware that voltage drops as cable resistance increases when extending the cable.

Code D : Diode for reverse connecting protection of power supply
 ZD1~ZD4 : Zener diode for surge voltage absorption
 Tr1~Tr4 : NPN output transistor

MULTI-CHANNEL FLOW RATE SENSOR CONTROLLERS

FSU



Specifications

● Multi-channel flow rate sensor controller

Item		Model	FSU
Power supply	Voltage		DC24V±10%
	Sensor head supply voltage		DC24V±10% ^{Note 1}
	Consumption current		100 mA MAX. (Not including current supplied to sensors)
Sensor input	Compatible sensor heads		Rated flow rate • -500~500 ml/min [-30.5~30.5 in ³ /min.] (ANR) type • -3~3 l/min [-0.11~0.11 ft ³ /min.] (ANR) type • 0~10 l/min [0~0.35 ft ³ /min.] (ANR) type
	Number of connectable sensors		1~4
	Input voltage range		DC1.0~5.0V
	Maximum input voltage		5.3V MAX.
SW output	Number of outputs		4
	Output method		NPN open collector
	Response time		3 ms
	Load voltage		DC30V MAX.
	Load current		50 mA MAX.
	Internal voltage drop		0.3V MAX./at load current 5 mA
	Output mode		Window comparator mode 1 Window comparator mode 2 Window comparator mode 3 Window comparator mode 4
	Switch output reversal		Compatible with window comparator mode 4 only
Display	Hysteresis		Variable (Can be freely set at 2 digits or more)
	Flow rate display		7-segment LED, 3-digit display
	Switch output display (SW.OUT)		Red LED lights up when ON
Setting method	Flow rate display channel indication (A.S.OUT)		Flow rate display channel green LED lights up
	Body key setting		△: UP, ▽: DOWN, ⊞: MODE
General	External setting (optional) ^{Note 2}		Conforms with RS232C
	Operating temperature range		-10~50°C [14~122°F], storage: -20~80°C [-4~176°F], (no condensation and freezing)
	Noise resistance		IEC61000-4-4 Power supply line: 1KV (level 2) Sensor input signal line: 1KV (level 3)
	Dielectric strength		AC500V 1 minute
	Insulation resistance		100 MΩ or more (at DC500V megger)
	Vibration resistance		88.3 m/s ² [9G] (total amplitude 1.5 mm [0.059 in.], 10~55 Hz)
	Shock resistance		294.2 m/s ² [30G] (Non-repeated shock)
	Material		Case: PBT
	Mass		45 g [1.59 oz.] (excluding cable)

Notes: 1. The supply voltage to the sensor head is lower by 0.5V MAX than the controller power supply voltage.
 2. FSU-S-D-□-□ only.

Wiring specifications

Connector type	Item	Specification	
B11B-XASK-1 made by JST	Power supply	1 pin : 24V (red)	
		2 pin : 0V (black)	
	Switch output	3 pin : SW1 (white)	
		4 pin : SW2 (green)	
		5 pin : SW3 (yellow)	
		6 pin : SW4 (brown)	
	Data input and output	RS232C ^{Note}	7 pin : 0V (blue)
			8 pin : RXD (brown)
			9 pin : TXD (black)
			10 pin : N.C
			11 pin : N.C
37104-3101 made by SUMITOMO 3M	Data input	1 pin : +V (brown)	
		2 pin : Sensor output (black)	
		3 pin : 0V (blue)	
		4 pin : PIN	

Note: FSU-S-D-□-□ only.

Specifications

● Flow rate sensor heads

Item	Model	FS-R3	FS-R05	FS-10
Gases targeted for measurement		Air/nitrogen. However, the detection media cannot contain chlorine, sulfur, acid, or other corrosive substances. Gas must also be dry. Gas must be clean gas devoid of dust and mist (oil mist).		
Measurement flow rate range		-3~+3 l/min [-0.11~0.11 ft ³ /min.]	-500~+500 ml/min [-30.5~30.5 in. ³ /min.]	0~+10 l/min [0~0.35 ft ³ /min.]
		Converted volume flow rate at 20°C [68°F], 1 atm [14.7 psi.]		
Response		5 ms or less (95% response to stepped changes in flow rate)		
Output signal		DC1~5V (nonlinear characteristics), Allowable load resistance 10 kΩ or more		
Operating temperature range		0~50°C [32~122°F] (for both ambient temperature and measured media temperature)		
Storage temperature range		-10~60°C [14~140°F]		
Operating and storage humidity range		10~80%RH (no condensation)		
Operating pressure range		-100~+200 kPa [-14.5~29.0 psi.] (Pressure characteristic warranty range is -70~+200 kPa [-10.2~29.0 psi.])		
Proof pressure		300 kPa [43.5 psi.]		
Output voltage accuracy		±5%FS MAX.	±5%FS MAX.	±5%FS MAX.
Standard flow rate characteristics		0.0 l/min [0.000 ft ³ /min.]: 3.00±0.15V	0.0 l/min [0.000 ft ³ /min.]: 3.00±0.20V	0.0 l/min [0.000 ft ³ /min.]: 1.00±0.20V
		0.5 l/min [0.018 ft ³ /min.]: 3.88±0.15V	0.1 l/min [0.004 ft ³ /min.]: 3.77±0.20V	3.0 l/min [0.106 ft ³ /min.]: 3.89±0.15V
		1.5 l/min [0.053 ft ³ /min.]: 4.49±0.15V	0.3 l/min [0.011 ft ³ /min.]: 4.53±0.20V	5.0 l/min [0.177 ft ³ /min.]: 4.46±0.15V
		3.0 l/min [0.106 ft ³ /min.]: 5.00±0.20V	0.5 l/min [0.018 ft ³ /min.]: 5.00±0.20V	10.0 l/min [0.353 ft ³ /min.]: 5.00±0.20V
Repeatability		±3.5%FS MAX.	±2%FS MAX.	±6%FS MAX.
		Assuming the same temperature and pressure conditions at time of measurement		
Pressure characteristics		±0.01%FS/kPa	±0.01%FS/kPa	±0.01%FS/kPa (0~+200 kPa [0~29.0 psi.])
		In -70~+200 kPa [-10.2~29.0 psi.] pressure range		±0.03%FS/kPa (-70~0 kPa [-10.2~0 psi.])
Temperature characteristics		0.0 l/min [0.000 ft ³ /min.]: ±0.1%FS/°C	0.0 l/min [0.000 ft ³ /min.]: ±0.1%FS/°C	0.0 l/min [0.000 ft ³ /min.]: ±0.1%FS/°C
		1.5 l/min [0.053 ft ³ /min.]: ±0.15%FS/°C	0.3 l/min [0.011 ft ³ /min.]: ±0.15%FS/°C	5.0 l/min [0.177 ft ³ /min.]: ±0.2%FS/°C
Power supply voltage		DC24V (supplied from sensor controller)		
Allowable voltage fluctuation range		In the DC21.6~26.4V range, ±2%FS or less in relation to output value at DC24V ^{Note 2}		
Output stabilization time		Time required to come within ±5%FS of final attained voltage (flow rate): Instantaneous Time required to come within ±1%FS of final attained voltage (flow rate): Within 10 sec.		
Consumption current		12 mA MAX.		
Dielectric strength		Between all external connector terminals and body: AC500V for 1 min., or AC600V for 1 sec.		
Insulation resistance		Between all external connector terminals and body: 50 MΩ (at DC500V megger)		
Connection method		M5 female thread (brass insertion), tightening torque at 2.5 N·m [1.84 ft·lbf] or less		
Material		Gas contact part: PPS plastic (flow path body), ceramic (substrate), brass (connections) Cover part: PC plastic (polycarbonate)		
Mounting direction		Any direction except where cover part faces downward		
Mounting conditions		When using the mounting holes on this device, use M3 screws and a tightening torque of 0.6 N·m [5.3in·lbf] or less. In addition, install a filter upstream from the device that is capable of collecting dust and mist particles of 10μm or larger.		
Straight piping length		Unnecessary either upstream or downstream from the device		
Vibration resistance		10~55 Hz, total amplitude 1.5 mm [0.059 in.], XYZ directions each two hours		
Mass		9 g [0.32 oz.]		
Electrical connection (special connectors)		Cable with dedicated connector		
		Flow rate sensor heads side: SM03B-SRSS-G-TB made by JST Mfg. Co., Ltd. Mating side: SHR-03V-S-B (housing), SSH-003GA-P0.2 (contact) made by JST Mfg Co., Ltd.		

Notes: 1. The %FS in the table assumes full-scale output voltage of 4V (1~5V).

2. Near the upper limit of the measurement flow rate range, output fluctuation after flow rate stabilization can be generated up to a maximum of ±1%FS (amount of drift 500 seconds after flow rate stabilization).

Flow Rate Sensor Head Flow Rate and Output Characteristics Graphs

● FS-R05

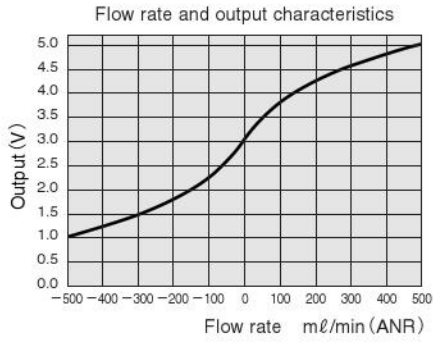

● FS-R3

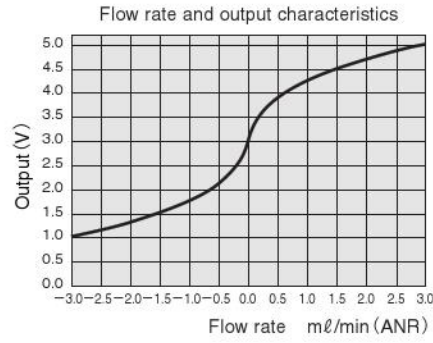

● FS-10

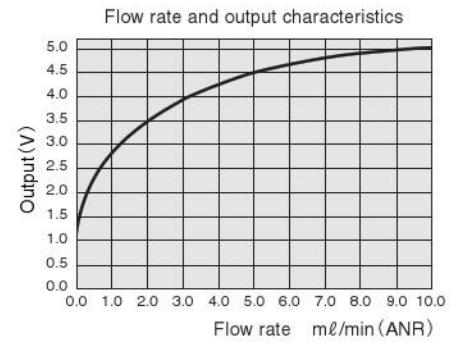

1 ml = 0.0610 in.³ 1 l/min = 0.03536 ft.³/min.

Order Codes

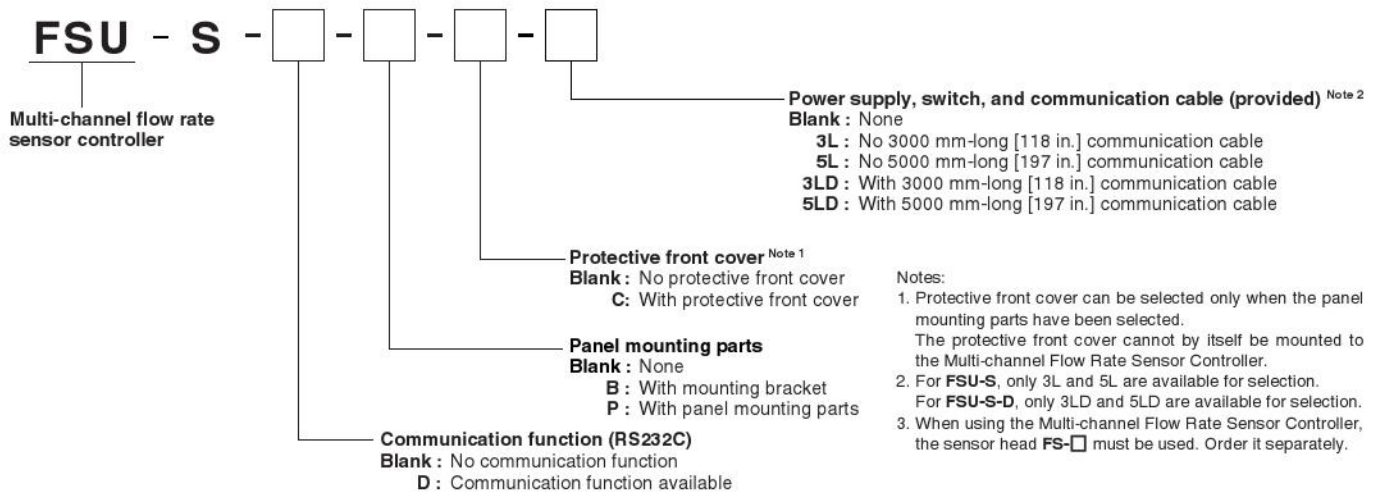

Additional Parts (To Be Ordered Separately)

Flow rate sensor head

● **FS** - []

Flow rate sensor head

Flow rate range

R05: -500~500 ml/min
 [-30.5~30.5 in.³/min.] (ANR)

R3: -3~3 l/min
 [-0.11~0.11 ft.³/min.] (ANR)

10: 0~10 l/min
 [0~0.35 ft.³/min.] (ANR)

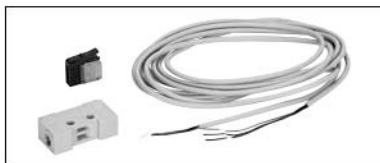

Sensor head connecting cable

● **PSUK** - []

Cable length

3L: 3000 mm [118 in.]
5L: 5000 mm [197 in.]



Power supply, switch, and communication cable

● **PSUW** - [] - []

Cable length

3L: 3000 mm [118 in.]
5L: 5000 mm [197 in.]

Communication cable

Blank: No communication cable ^{Note 1}
D: With communication function ^{Note 2}



Notes: 1. Can be used with **FSU-S** only.
 2. Can be used with **FSU-S-D** only.



Dimensions mm [in.]

● FSU-S-□

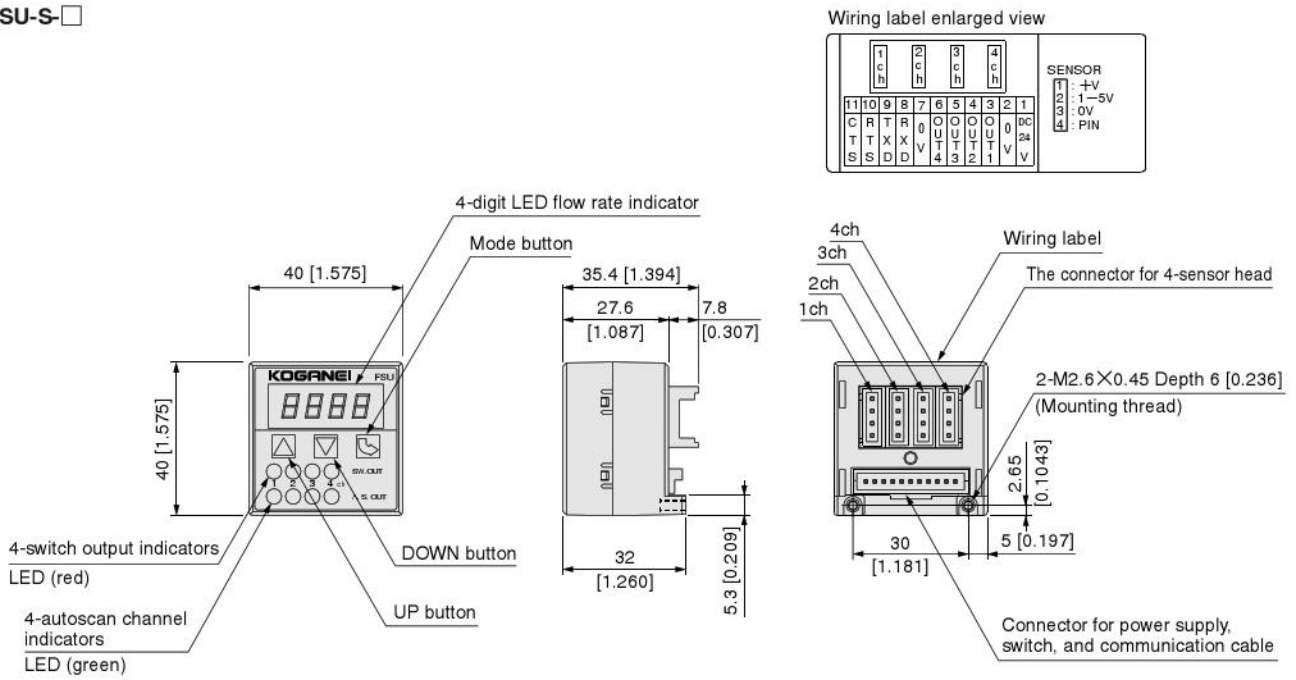

● FS-□

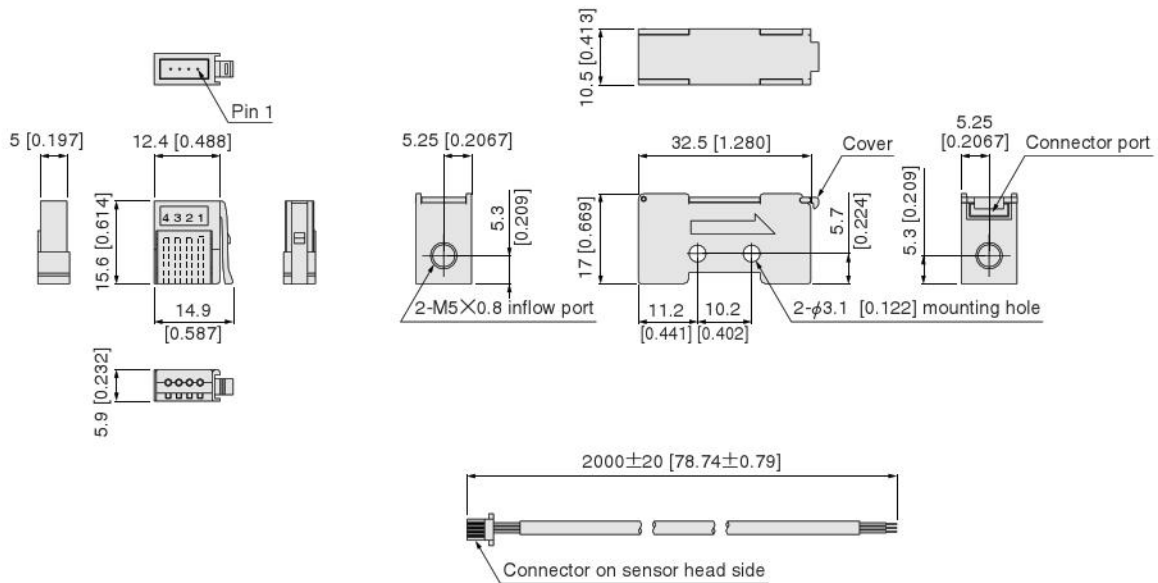

● PSUK-□

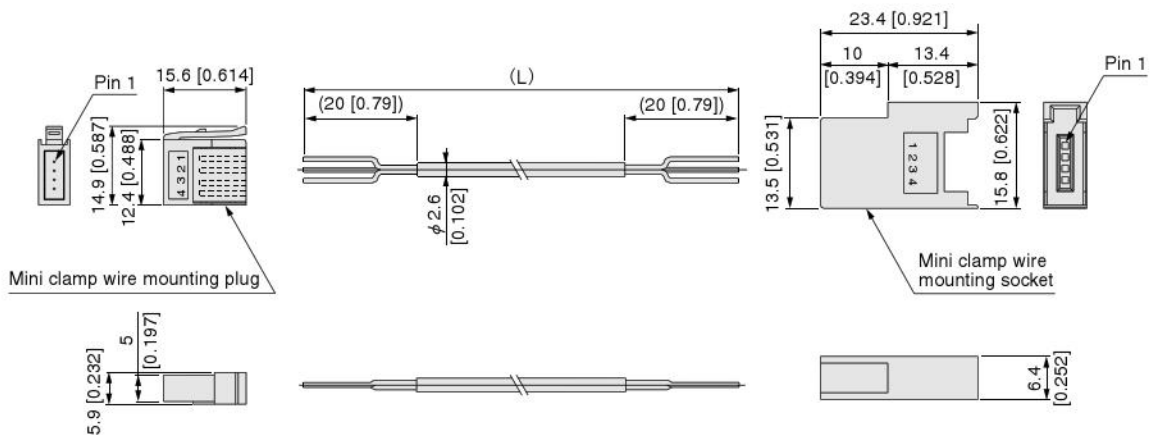

Model	L
PSUK-3L	3000 [118]
PSUK-5L	5000 [197]

Dimensions mm [in.]

● PSUW-□-□

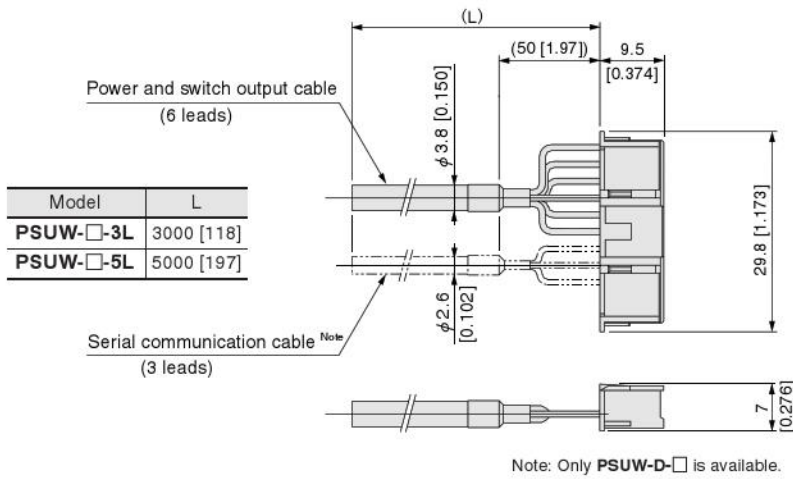

● PSU-BR

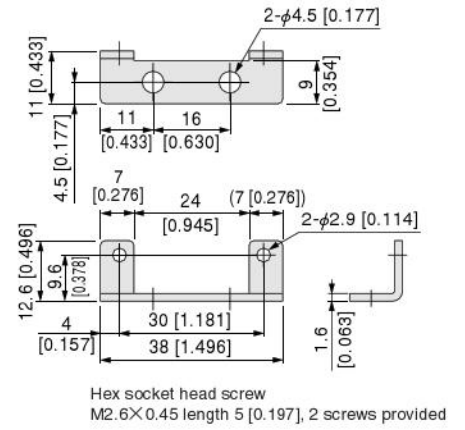

● PSU-□-P (Drawings for panel mounting)

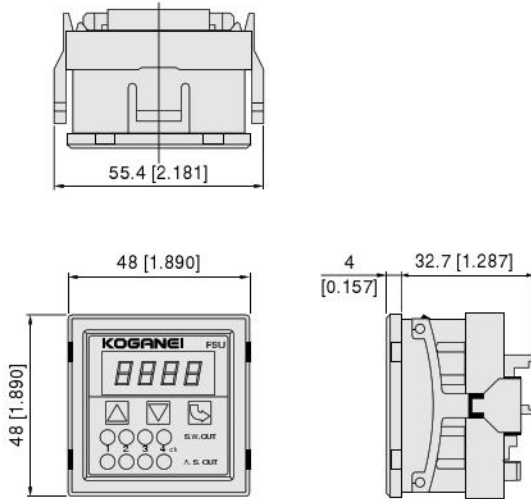

● Dimensions of cut panel for sensor controller mounting

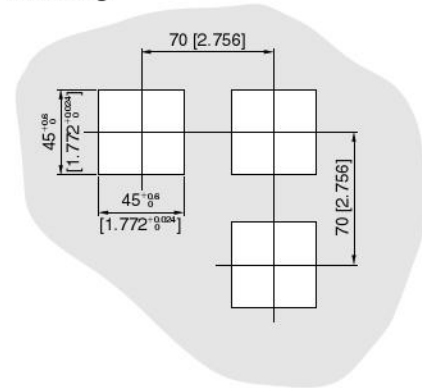

- Notes:
1. The mounting plate thickness should be 1~3.2 mm. [0.039~0.126in.]
 2. If mounting in a series, space the units at intervals of the value shown in the figure above or greater.
 3. Conforms to **DIN43700** standard.

● KB100

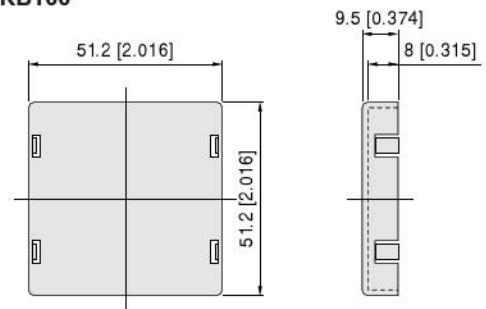



● Vacuum Valve Unit with flow rate sensor

CRCB-0064W

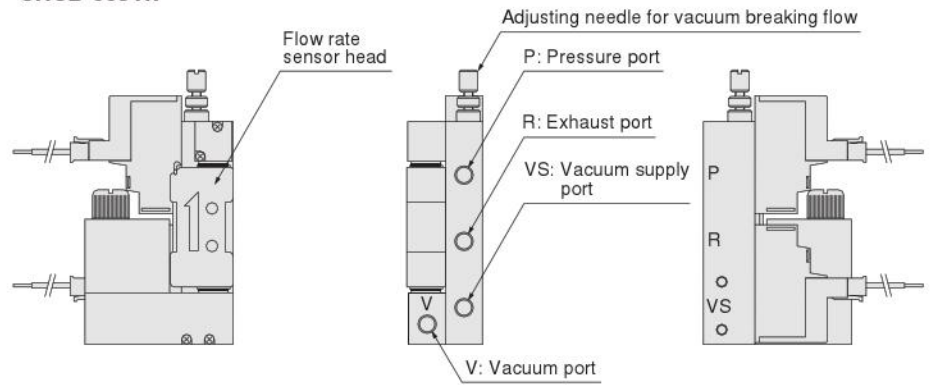

● Micro ejector with flow rate sensor

CRCB-0065W

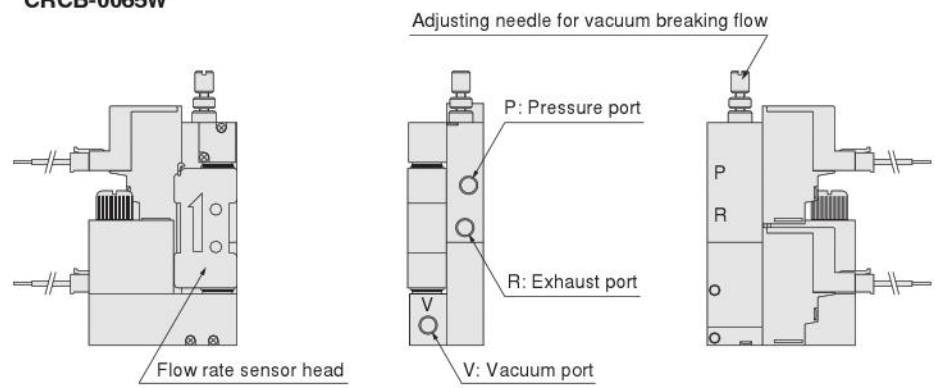

Note: For detailed specification and dimension, consult us.