



With water and fluids removal functions  
**FRZB Filter Regulator** NPT thread specifications

**Down sizing**  
 Close side-by-side spacing

**Improved operability**  
 Improved knob operability and simple bowl  
 installation and removal



**NEW VARIATION !!**

- NPT thread specifications
- PSI gauge

With water and fluids removal functions

# FRZB Filter Regulator

Easy-to-use water and fluids removal functions inside a compact design!

Specialized **30 series**  
for standalone application



1.378



FRZB30

The **40 and 50 series**  
can be used in combination with the FRZ series



1.575



FRZB40



1.969



FRZB50

**Down sizing**

Improved flow rate characteristics allow a smaller configuration (close side-by-side spacing is possible).

**Improved operability and maintainability**

Improved knob operability and simple bowl installation and removal.

**Pressure gauge, pressure switch**

Supports  1.181 in. integrated pressure gauges, other pressure gauges, and pressure switches.

**Supports a wide variety of environments**

Ozone resistance specifications and NCU specifications (copper free)<sup>Note</sup> are standard.

Note: Excluding pressure switch and pressure gauge options.



## Compact design

Improved flow rate characteristics enable a smaller configuration.

\*Comparison of our FR600 and FRZB50 filter regulators.

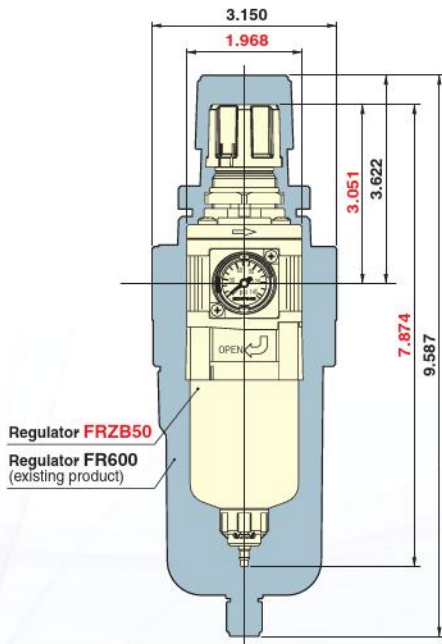

Regulator **FRZB50**  
Regulator **FR600**  
(existing product)

## Improved knob operability

- The knob is ideally sized and shaped to turn smoothly with a light touch for easy operation. Also, the knob lock precision has been improved to reduce changes in pressure settings when the knob is locked.
- The status of the knob lock release can be checked with the yellow caution ring.

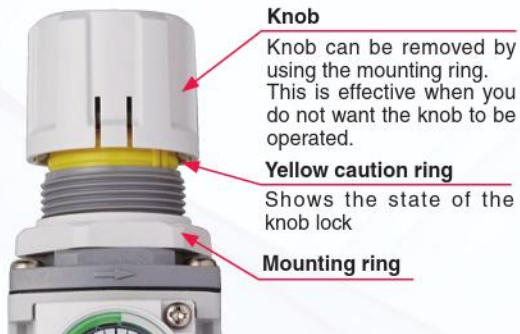

**Knob**  
Knob can be removed by using the mounting ring. This is effective when you do not want the knob to be operated.

**Yellow caution ring**  
Shows the state of the knob lock

**Mounting ring**

## Drain cock specifications

Drain cock with fitting or auto drain types can be selected for the drain cock specifications.



Auto drain type  
NO (Normally open)  
NC (Normally closed)



Drain cock with fitting

## 1.181 in. series integrated pressure gauge

- 1.181 in. integrated pressure gauge is compact with almost nothing sticking out. Visibility is also improved with an easy to see 270° swing angle display.

270° swing angle



- PSI gauge and NPT thread specifications are also available now.
- Flexible change of the pressure setting range (the green part) is possible. Freely changeable upper and lower setting limits eliminate the need to remove the front cover (the transparent plastic part) and to use special tools.

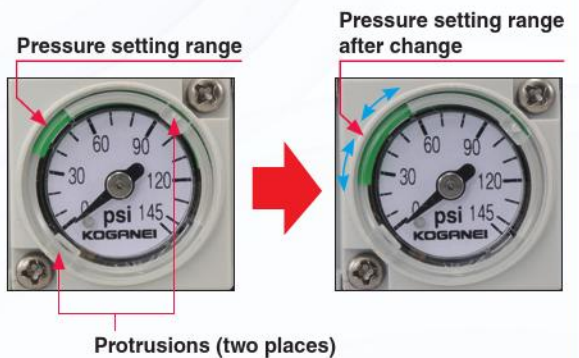

The setting pressure range display can be changed as desired by rotating the protrusions (two locations) clockwise or counter clockwise.

\* Other pressure gauges and pressure switches are available. See the next page for details.

## Bowl guard (option)

Bowl guard option is available.



## Pressure gauge, pressure switch

Can select various types of pressure gauges and pressure switches other than the □1.181 in. integrated pressure gauge. PSI GAUGE NEW

### Order code G1-40-F11

φ1.575 in. pressure gauge  
(145 psi specifications)

### G3-40-F11

φ1.575 in. pressure gauge  
(43.5 psi specifications)

### G1S-40-F11

φ1.575 in. stainless steel  
Bourdon tube pressure gauge  
(145 psi specifications)

### G3S-40-F11

φ1.575 in. stainless steel  
Bourdon tube pressure gauge  
(43.5 psi specifications)



Digital pressure switch  
GS620-3W  
(145 psi specifications)

### GS1-50-F11-□-□

Pressure gauge with built-in  
switches  
(145 psi specifications)

## Bracket

The brackets can be used with all sizes of the FRZB filter regulators.

Brackets can also be used with the IB-Cyclone and FRZ series.



## Panel mounting

A φ1.122 in. panel mounting hole can be used for all sizes of the filter regulators.

Note: There are limitations to the mounting (installation) orientation of the FRZB filter regulators.

## Guide to related products

New-generation Filter Regulator

# FRZ Series *Excellent for air lines with water and fluids already removed!*

Specialized **30 series**  
for standalone application



Regulator  
RZ30

Filter regulator  
FRZ30

The **40 and 50 series**  
can be used in combinations



Regulator  
RZ40

Filter regulator  
FRZ40







Regulator  
RZ50

Filter regulator  
FRZ50

Before selecting and using the products, please read all safety precautions carefully to ensure proper product use. The safety precautions described below are to help you use the product safely and correctly, and to prevent injury or damage to you, other people, and assets.

Always adhere to the following safety regulations: ISO4414 (Pneumatic fluid power - General rules and safety requirements for systems and their components) and JIS B 8370 (General rules relating to systems).

The directions are ranked according to degree of potential danger or damage: "DANGER", "WARNING!", "CAUTION!", and "ATTENTION!".

 <b>DANGER</b>	Indicates situations that can be clearly predicted as dangerous. Failure to avoid the situation creates the risk of death or serious injury. It could also result in damage or destruction of assets.
 <b>WARNING</b>	Indicates situations that, while not immediately dangerous, could become dangerous. Failure to avoid the situation creates the risk of death or serious injury. It could also result in damage or destruction of assets.
 <b>CAUTION</b>	Indicates situations that, while not immediately dangerous, could become dangerous. Failure to avoid the situation creates the risk of minor or semi-serious injury. It could also result in damage or destruction of assets.
 <b>ATTENTION</b>	While there is little chance of injury, this content refers to points that should be observed for appropriate use of the product.

### ■ This product was designed and manufactured for use in general industrial machinery.

- When selecting and handling equipment, the system designer or another person with sufficient knowledge and experience should always read the safety precautions, catalog, instruction manual and other literature before commencing operation. Improper handling is dangerous.
- After reading the instruction manual, catalog, and other documentation, always store them in a location that allows easy availability for reference to users of this product.
- Whenever transferring or lending the product to another person, always attach the catalog, instruction manual, and other information to the product where they are easily visible in order to ensure that the new user can use the product safely and properly.
- The danger, warning and caution items listed under these safety precautions do not cover all possible contingencies. Read the catalog and instruction manual carefully, and always keep safety first.

### **DANGER**

- Do not use the product for the purposes listed below:
  1. Medical equipment related to maintenance or management of human lives or bodies.
  2. Machines or equipment designed for the purpose of moving or transporting people.
  3. Critical safety components in mechanical devices.
 This product has not been planned or designed for purposes that require high levels of safety. Using the product in any of the ways described above creates the risk of loss of human life.
- Do not use the product in locations with or near dangerous substances such as flammable or ignitable substances. This product is not explosion-proof. Doing so creates the risk of ignition and fire.
- When mounting the product, always make sure they are firmly supported and secured in place. Falling, dropping, or abnormal operation of the product creates the risk of personal injury.
- Never attempt to modify the product. Doing so can cause malfunctions and create the risk of personal injury, electric shock, fire, etc.
- Never attempt inappropriate disassembly, assembly or repair of the product relating to basic construction, or to its performance or to functions. Doing so creates the risk of injury, electric shock, fire, etc.
- Do not splash water on the product. Spraying it with water, washing it, or using it under water could result in malfunction of the product leading to injury, electric shocks, fire, etc.
- While the product is in operation, avoid touching it with your hands or otherwise approaching too close. Also, do not attempt to make any adjustments to internal or attached mechanisms, or to perform any type of adjustment (disconnecting cable connectors, adjusting pressure switches, disconnecting tubes or sealed plugs, adjusting the product's mounting position, etc.) while the product is in operation. There is a risk of personal injury if the product falls or operates abnormally.

### **WARNING**

- Because Koganei products are designed for use under a wide variety of conditions, decisions concerning conformance with a particular system should be made upon the careful evaluation by the person in charge of system design. Assurances concerning expected system performance and safety are the responsibility of the designer who decides system conformity. Be sure to use the latest catalogs and technical materials to study and evaluate specification details, to consider the possibility of machine breakdown, and to configure a system that ensures fail-safe safety and reliability.

- Do not use the product in excess of its specification range. Doing so creates the risk of product breakdown, loss of function, or damage. It could also drastically reduce operating life.
- Before supplying air or electricity to the device and before starting operation, always conduct a safety check of the area of machine operation. Unintentional supply of air or electricity creates the risk of injury due to contact with moving parts.
- Do not touch terminals, switches, or other parts, while power is turned on. Doing so creates the risk of electric shock and malfunction.
- Do not allow the product to be thrown into fire. Doing so creates the risk of explosion resulting in the release of toxic gases.
- Do not sit on the product, place your foot on it, or place other objects on it. Doing so creates the risk of injury due to tripping or the product tipping over or falling, resulting in product damage and abnormal, erratic, or runaway operation.
- Before conducting maintenance, inspection, repair, replacement, or any other similar procedure, always completely cut off the air supply and confirm that residual pressure inside the product or in piping connected to the product is atmospheric pressure. In particular, be aware that residual air will still be in the compressor or storage tank. The actuator may move abruptly if residual air pressure remains inside the piping, causing injury.
- Use safety circuits or design a system that prevents damage to machinery or injury to personnel when the machine is shut down due to an emergency stop or electrical power failure.
- Before performing any kind of wiring work, be sure to turn off power. Failure to do so creates the risk of electric shock.
- Do not allow lead wires and other cords to become damaged. Allowing a cord to become cut, bent excessively, pulled, rolled up, placed under heavy objects, or squeezed between two objects creates the risk of current leaks or defective continuity that can lead to fire, electric shock, or abnormal operation.
- Do not connect or disconnect connectors while power is turned on. Also, never apply unnecessary force to connectors. Doing so creates the risk of personal injury, device damage, and electric shock due to abnormal machine operation.
- Always check the catalog and other reference materials for correct product wiring and piping. Improper wiring and piping creates the risk of damage to and abnormal operation of the actuator, etc.
- After completing wiring work, check to make sure that all connections are correct before turning on power.
- Be careful when wiring, do not reverse the polarity of wires. Incorrect polarity may damage the pressure switch.
- After completing piping work, check to make sure that the circuit is correct before supplying air.
- Do not use any type of medium that is not specifically stipulated in the specifications. Using a non-specified medium could lead to loss of function in the short term, sudden degradation of performance, and a reduced operating life.
- In initial operations after the equipment has been idle for 48 hours or more, or has been in storage, there is a possibility that

## Safety precautions (FRZB filter regulators)

contacting parts may have become stuck, resulting in equipment operation delays or in sudden movements. Before these initial operations, always run a test to check that operating performance is normal.

- Do not use the product in locations that are subject to direct sunlight (ultraviolet rays); locations with high humidity and temperature, dust, salt, or iron powder. Do not use fluids in the product or use the product in an environment that includes corrosive fluids such as organic solvents, phosphate ester type hydraulic oil, sulfur dioxide, chlorine gas, freon gas, ozone, acids, alkaline, etc. It could lead to early shutdown of some functions, a sudden degradation of performance, and a reduced operating life. For information about materials, see Major Parts and Materials.
- When the device is not used for long periods (over 30 days), it is possible that the contacting parts may have become stuck leading to delayed operation or sudden movements, resulting in injury. Check for proper operation a minimum of once every 30 days.
- Do not expose the main unit to an external magnetic field when the pressure switch is operating. It could cause erratic operation resulting in injury or damage to the machine.
- Do not wire parallel to power lines or high-voltage lines, or inside the same wiring conduit. The noise could cause the pressure switch to malfunction.
- Do not use the product near the sea, in direct sunlight, near mercury vapor lamps, or near equipment that generates ozone. Ozone causes rubber components to deteriorate resulting in reduced performance, or degradation or stop of functions.
- Do not use in locations where there is a heat source nearby or that are subject to radiated heat.



### CAUTION

- When mounting the product, leave room for adequate working space around it. Failure to do so will make it more difficult to conduct daily inspections or maintenance, which could eventually lead to system shutdown or damage to the product.
- Whenever transporting or installing a heavy product, use a lift or supports to securely support it, and use several people to help lift it and take other precautions to ensure personal safety.
- Do not scratch, dent, or deform the product by climbing on it, using it as a step, or placing objects on top of it. Doing so creates the risk of damage to or breakage of the product, resulting in operational shutdown or degraded performance.
- Always post an operations in progress sign for installations, adjustments, or other operations, to avoid unintentional supplying of air or electrical power, etc. Unintentional supplying of air or electricity can cause electric shock or sudden operation and may result in injury.
- While handling the product, do not subject it to extreme shocks by hitting, dropping, or bumping it. Doing so may damage the inside of the product, even though the outside is not damaged, and cause it to malfunction.
- Do not short circuit the load to the pressure switch. The pressure switch may be damaged by over-current if the comparative output is turned on while the load is short circuited. Example of short circuited load: The output lead wire of the comparative output is connected directly to the power source.
- Do not bring any magnetic media or memory within one meter [3.28 ft] of the product. There is a strong magnet inside the product and the magnetic field of this magnet may damage the data on the magnetic media.
- If an electric leakage occurs on the control circuit, it may cause the product to operate unexpectedly. Protect the control circuit from electricity leaks so that electricity leaks do not exceed the allowance in the product specifications.
- Use the specified lubricant to lubricate sliding parts. Not doing so leads to changes in the physical properties, deterioration of the materials used, or reduced functionality.
- Do not block the product's vent holes. The pressure will fluctuate if the air volume changes during operations. If the vents are blocked the pressure balance will be disrupted, operations will no longer be as expected resulting in injury or damage to equipment.
- Use in extremely dry air under temperatures lower than -20°C [-4°F] may affect the quality of the lubricating oil used. This creates the risk of degraded performance, loss of function, or other problems.



### ATTENTION

- When considering the possibility of using this product in situations or environments not specifically noted in the catalog or instruction manual, or in applications where safety is an

important requirement such as in aircraft equipment, combustion equipment, leisure equipment, safety equipment, and other places where human life or assets may be greatly affected, take adequate safety precautions such as allowing plenty of margin for ratings and performance, or fail-safe measures.

Always contact the sales department at Koganei regarding use in such applications.

- Use a protective cover and other means to ensure that the operating parts of mechanical devices are isolated and do not come into direct contact with human bodies.
- Do not configure control of the actuator in a way that could cause workpieces to fall due to power failure. Configure control of the system to prevent workpieces and other items from falling due to power failure or by emergency stops of mechanical devices.
- Attach a muffler to the exhaust port. It will reduce the noise during exhaust.
- Lock the pressure regulation knob after regulating the pressure.
- When handling the product, wear protective gloves, safety glasses, safety shoes, and other protective clothing.
- When the product can no longer be used or is no longer necessary, dispose of it appropriately as industrial waste.
- Pneumatic equipment can exhibit degraded performance and function over its operating life. Always conduct daily inspections of the pneumatic equipment, and confirm that all requisite system functions are satisfied, to prevent accidents from happening.
- For inquiries about the product, consult your nearest Koganei sales office or Koganei Overseas Department. The addresses and telephone numbers are shown on the back cover of this catalog.



### Other precautions

- Always observe the following items.
  1. When using this product in pneumatic systems, always use genuine Koganei parts or compatible parts (recommended parts). When conducting maintenance and repairs, always use genuine Koganei parts or equivalent parts (recommended parts). Always observe the prescribed methods and procedures.
  2. Never attempt inappropriate disassembly or assembly of the product relating to basic configurations, or its performance or functions.
  3. The sales of pressure gauges with PSI indications in Japan are prohibited by the Japanese law.

Koganei shall not be held responsible for any problems that occur as a result of these items not being properly observed.

### Warranty and General Disclaimer

1. **Warranty Period**  
Koganei warrants this product for a period of no more than 180 days from the date of delivery.
2. **Scope of Warranty and General Disclaimer**
  - (1) The Koganei product warranty covers individual products. When a product purchased from Koganei or from an authorized Koganei distributor malfunctions during the warranty period in a way that is attributable to Koganei responsibility, Koganei will repair or replace the product free of charge. Even if a product is still within the warranty period, its operating life is determined by its operation cycles and other factors. Contact your nearest Koganei sales office or the Koganei overseas department for details.
  - (2) Koganei shall not be held responsible for any losses or for any damage to other machinery caused by breakdown, loss of function, or loss of performance of Koganei products.
  - (3) Koganei shall not be held responsible for any losses due to use or storage of the product in a way that is outside of the product specifications prescribed in Koganei catalogs and the instruction manual, and/or due to actions that violate the mounting, installation, adjustment, maintenance and other safety precautions.
  - (4) Koganei shall not be held responsible for any losses caused by breakdown of the product due to factors outside the responsibility of Koganei, including but not limited to fire, natural disaster, the actions of third parties, and intentional actions or errors by you.

# Handling instructions and Precautions (FRZB Filter Regulators)

## For all FRZB Filter Regulators

### Design and selection

#### ● Selection

Look at the Handling Instructions and Precautions, Specifications, Various Characteristics, Dimensions, and other technical materials for each product to make the correct decision.

### Mounting (installation) and piping

#### ● Mounting (installation) direction, support, and securing

1. The products cannot be mounted (installed) if a bending moment or twisting moment is applied to the product or piping.

 Applying bending moment or twisting moment may damage the product.

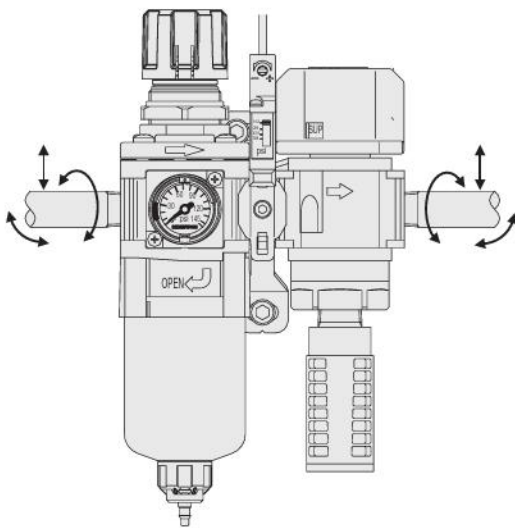

 The muffler must be prepared by the user.

2. Do not attach piping so that just one side is fixed as shown in the following diagram. Support external piping separately.

 Operating the knob and the moment caused by the OUT (secondary) side pipes may damage the product's piping connections.

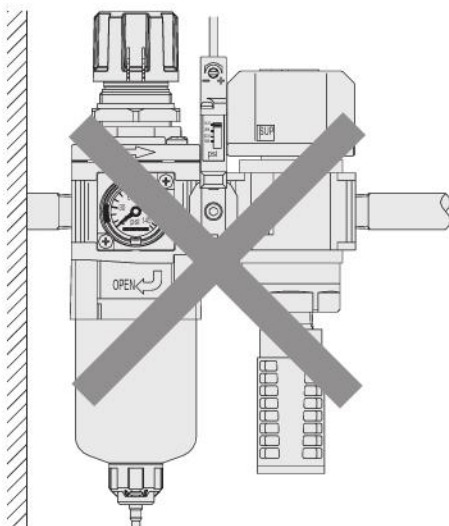

3. Use the brackets to install the products.  
4. When mounting (installing) products, always make sure they are secured and sufficiently supported.

 If a product is not securely fixed in place, it may fall over, be dropped, or operate abnormally and cause an injury.

#### ● Maintenance space requirements

Assure there is sufficient space for maintenance inspections and maintenance work.

See the dimension diagrams for each of the products regarding the maintenance space.

 If there is not enough allowance for maintenance space, it is impossible to remove the bowl assembly and replace the filter.

Also, it is impossible to do maintenance inspections so the equipment may stop or the product may be damaged.

#### ● Attaching steel pipes and fittings

If steel pipes and fittings are attached to the threaded sections of the aluminum die-cast parts of the product, tighten them to the torque recommended in our standards.

 Tightening with excessive torque may damage the product or injure workers or operators.

#### Recommended tightening torque

Connecting thread	M5	1/8	1/4	3/8	1/2	ft·lbf
Torque	0.7 to 1.1	5.2 to 6.6	8.9 to 10.3	16.2 to 17.7	20.7 to 22.1	

 Use a tightening torque of 2.21 to 3.69 ft·lbf if the various pressure gauges are mounted on the NPT1/8 or NPT1/4 pressure port plate.

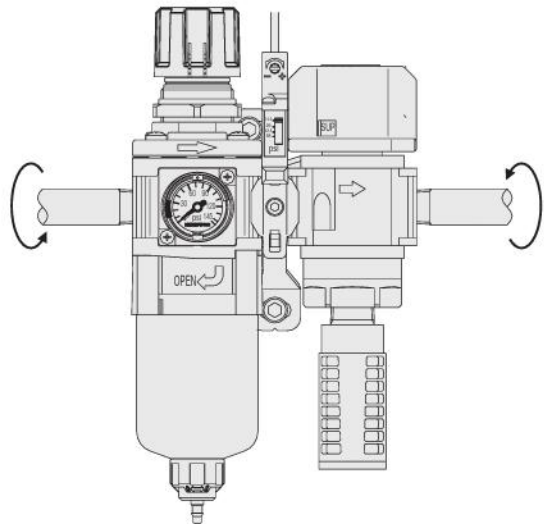

#### ● Preventing contamination by foreign matter

1. Remove all foreign matter, such as metal chips, cutting oil, or dirt, from inside pipes with compressed air blow (flushing) and thorough washing before fitting the pipes.

2. Do not allow foreign matter, such as metal chips, or sealing tape from the piping threads, to get into the pipes when installing the pipes and fittings.

 Foreign matter entering the piping may damage the product or reduce its performance and service life.

## Handling instructions and Precautions (FRZB Filter Regulators)

3. Wrap the sealing tape in the direction as shown in the diagram below leaving 1.5 to 2 threads uncovered. When using liquid sealant, apply a suitable amount and in the same way leave 1.5 to 2 threads uncovered.

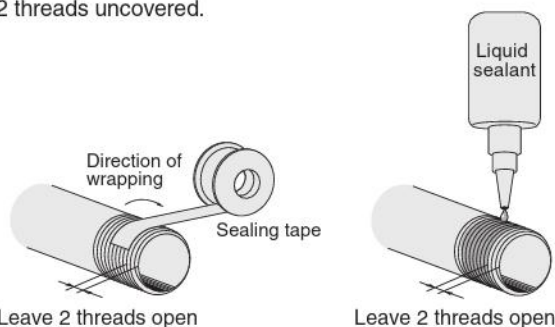

**Note** If the sealing tape or sealant gets on the lip of pipes or fittings, bits of it may get into the pipes and cause air leaks.

4. If you are using liquid sealant, do not get it on the polycarbonate parts (the bowl of the filter regulator and the front cover of the pressure gauge).

**Note** If liquid sealant gets on the polycarbonate parts, it may damage them.

### Medium and operating environment

#### ●Usable medium

1. Use clean air (filtered to below 40  $\mu\text{m}$ ) for the medium. Contact the nearest Koganei sales office or overseas department if you are considering using something other than clean air.

**Note** Contact a Koganei sales office or overseas department if you are considering using something other than air.

2. Avoid using air that contains too much water and/or fluids.

**Note** Using air that contains too much water and/or fluids will cause the product's functions to stop after a short period and will reduce the product performance and service life.

3. If air that contains water and/or fluids is used, or if it is possible that they may be mixed in with the air being used, we recommend using the iB-Cyclone to reliably remove water and fluids.

**Note** If you use an iB-Cyclone, install an FRZ series filter regulator (without water and fluids removal functions) on the secondary side.

4. Do not use the product if the medium being used is prone to extreme pulsating or surging.

**Note** Medium prone to extreme pulsating or surges will cause the product's functions to stop after a short period and will reduce the product performance and service life.

#### ●Operating environment

1. Do not use the product in locations that are subject to direct sunlight (ultraviolet rays); locations with high humidity and temperature, dust, salt, or iron powder.
2. Cover the unit when using it in locations where it might be subject to excessive dust, dripping water, dripping oil, etc.
3. Do not use the product in environments subject to external vibration or impact.

**Note** External vibrations or shocks may result in damage to component parts.

4. Avoid piping that is rigid, such as steel piping, if vibrations are transmitted. Use flexible tubes so that the product is not subject to the vibrations.

#### ●Medium and operating environment

1. The temperature of the medium and the ambient environment must be within the range in the specifications.

**Note** Using the product in an environment that is outside the specified temperature or with medium that is outside the specified temperature will cause the product's functions to stop after a short period and will reduce the product performance and service life.

2. Use a device, such as a freeze-type air dryer or after cooler, to lower the dew-point temperature of the medium to below the ambient temperature so condensation or frost does not occur in the secondary pipes.

**Note** If condensation or frost forms in the product, it may get into the secondary side.

3. Do not use medium in the product or use the product in an environment that includes corrosive components such as organic solvents, phosphate ester type hydraulic oil, sulfur dioxide, chlorine gas, freon gas, ozone, acids, alkaline, etc.

**Note** Using the product in an environment or with medium that is specified in the above item 3 will cause the product's functions to stop after a short period and will reduce the product performance and service life.

4. The bowl and the front cover of the pressure gauge of the filter regulator are polycarbonate. This product cannot be used in environments with the gases and fluids in item 3, nor thread-locking adhesive, leak detection fluid, hot water or where it may be exposed to them. This product also cannot be used in direct ultra-violet light. See page 16 for details.

### Operation and maintenance inspections

#### ●Method of use

Read the Handling Instructions and Precautions for each product for instructions on correct usage (Filter regulator page 8 to 14, and □1.181 in. integrated pressure gauge page 14).

#### ●Maintenance (maintenance inspection)

1. Performance and functions may decrease as the pneumatic equipment ages. Always conduct daily inspections of the pneumatic equipment, and confirm that all requisite system functions are satisfied, to prevent accidents from happening.
2. Read the Handling Instructions and Precautions for instructions on maintenance and replacing maintenance parts (Filter regulator page 13 to 14).
3. The product must be disassembled and reassembled to use the seal kit.

**Note** The product is no longer under warranty if it is disassembled and reassembled.



## Filter regulator (With water and fluids removal functions)

### Design and selection

#### ●Direct installation on compressor

Do not install the product directly on a compressor. Use sufficient countermeasures for temperature control, and removing oils and solids before use.

**Note** Not using countermeasures may cause the product's functions to stop after a short period and may reduce the product performance and service life.

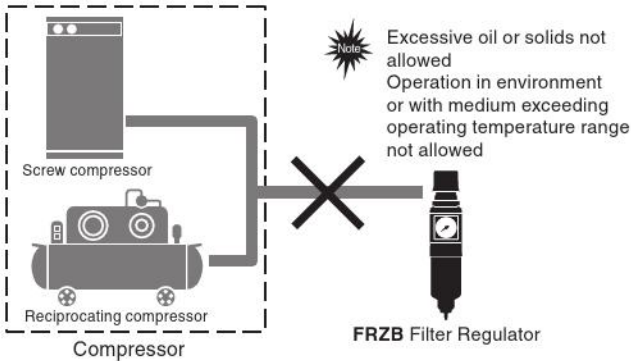

#### ●Water and fluids removal functions

1. The FRZB Filter Regulator's built-in water and fluids removal functions are simplified ones. Water and fluids removal efficiency varies according to conditions.

**Note** Use an iB-Cyclone to completely remove water and fluids.

2. See page 16 "Principles of water and fluids removal" regarding the water and fluids removal principles for the FRZB filter regulator series.

#### ●Humidity and oil mist removal

1. Filter regulators cannot remove humidity.

**Note** Install a membrane type air dryer or something on the secondary side if dehumidifying is needed.

2. Filter regulators cannot remove oil mist.

**Note** Install a mist filter or something on the secondary side if oil mist removal is needed.

#### ●Pressure setting

1. A safety device must be installed for equipment/devices installed on the OUT port (secondary) side of the filter regulator, when the equipment/device will be damaged or malfunction due to the pressure if the set pressure value is exceeded.

2. We recommend setting the pressure on the OUT port (secondary) side to less than 85% of the supply pressure setting on the IN port (primary) side.

**Note** If the pressure is set above 85%, the effect of the fluctuations in the IN port (primary) side pressure and flow rate are more prone to affect the OUT port (secondary) side pressure, and it becomes unstable.

3. It is not possible to install a valve on the IN port (primary) side of the internal pilot type filter regulator (such as models FRZB4□, FRZB5□) to repeatedly switch the pressure on the IN port (primary) side.

**Note** Changing the pressure of the IN port (primary) side may cause fluctuation in the OUT port (secondary) side set pressure.

4. The OUT port (secondary) side pressure may vary if air is not consumed for a long time or if a sealed circuit or balance circuit is used. Contact a Koganei sales office or overseas department.

5. Contact a Koganei sales office or overseas department if you are using a circuit that needs highly precise pressure regulation.

#### ●OUT port (secondary) side pressure exhaust and vent hole

1. When the knob on the filter regulator is turned to reduce the OUT port (secondary) side pressure or when the OUT port (secondary) side pressure is higher than the set pressure and is exhausted, air is exhausted to the outside through the vent hole shown in the diagram.

**Note** There may be some vibration and noise caused by the exhaust.

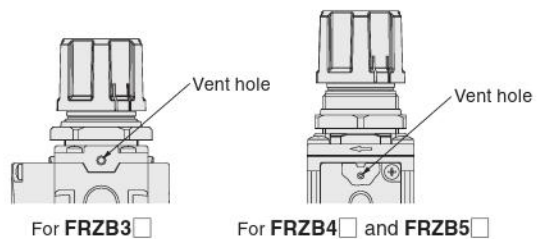

2. Install a separate exhaust mechanism on the OUT port (secondary) side if an external force applied to an actuator or something on the OUT port (secondary) side of the filter regulator generates a sudden pressure increase.

**Note** The relief port is smaller than the diameter of the pipe and may not be able to adapt to the sudden rise in pressure of the OUT port (secondary) side.

## Handling instructions and Precautions (FRZB Filter Regulators)



### Filter regulator (With water and fluids removal functions)

#### ●Reverse flow from the OUT port (secondary) side to the IN port (primary) side (residual pressure exhaust)

1. Select a filter regulator (such as model FRZB32) with built in check valve specifications for releasing residual pressure on the IN port (primary) side to reduce pressure on the OUT port (secondary) side of a direct operation type filter regulator (such as models FRZB30 and FRZB31).

**Note** Reducing residual pressure on the secondary side with the standard specifications and low-pressure specifications may not be possible depending on the operating conditions.

2. The internal pilot type filter regulators (such as models FRZB4□ and FRZB5□) use the relief port on the OUT port (secondary) side to reduce residual pressure when the IN port (primary) side pressure is released.

**Note** Install a residual pressure exhaust valve on the OUT port (secondary) side because exhausting air requires some time if the volume of the flow path of the OUT port (secondary) side is large.

3. When using a built-in check mechanism specification filter regulator (such as model FRZB32) that is installed after the valve to adjust the thrust of the actuator, set the pressure on the OUT port (secondary) side of the built-in check mechanism specification filter regulator not to rise above the set pressure, which may be caused by the back pressure of the actuator. (As a guideline, the difference in pressure for the push side and the pull side of the actuator should be 43.5 psi or less.)

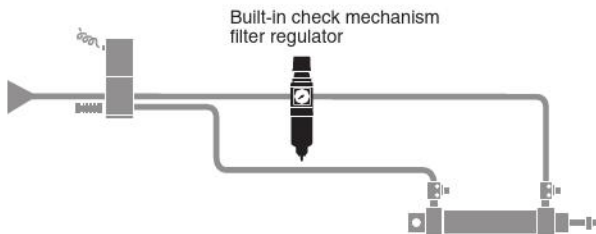

#### ●Air consumption

1. The internal pilot type filter regulators (such as models FRZB4□ and FRZB5□) consume air while regulating pressure on the OUT port (secondary) side.
2. Air consumption varies depending on the relationship of the IN port (primary) side pressure and the OUT port (secondary) side pressure.
3. The internal pilot type filter regulators (such as models FRZB4□ and FRZB5□) reduce pressure by consuming air when the IN port (primary) side and OUT port (secondary) side are cut off and sealed.

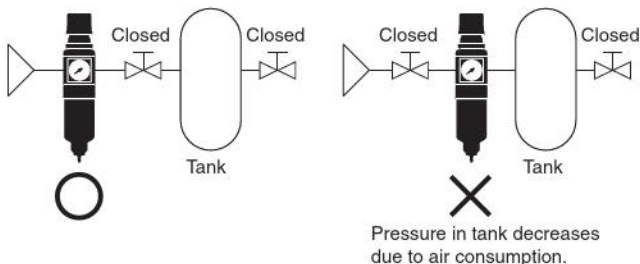

### Mounting (installation) and piping

#### ●Mounting (installation) direction

Mount (install) FRZB filter regulators vertically so the knob is up and the drain port is down.

#### ●Direction of flow

1. Connect the filter regulators so that the medium flows in the IN port (primary) side and flows out the OUT port (secondary) side.
2. Use the flow marks on the products to identify the primary port and secondary port of the filter regulator.

**Note** Reversing the IN port (primary) side and the OUT port (secondary) side connections damages the product and causes it to stop functioning.

#### ●Flow mark

The following diagram shows the relationship of the direction of flow of the medium and the flow mark on the filter regulator.

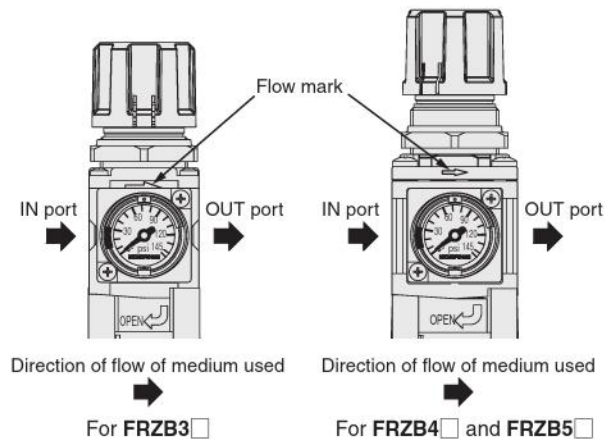

#### ●Piping work

When connecting steel pipes and/or fittings to the filter regulator IN ports and/or OUT ports, install them so the weight and torque of the pipes do not affect the product. When tightening the piping, grip the main unit and tighten it to the torque recommended on page 6.

**Note** Applying unnecessary force or impact to the knob, bowl assembly, or pressure gauge may damage component parts.

#### ●Installing brackets

To install brackets, do it in the following order.

- ① Remove the knob.  
(For how to remove the knob see "Removing the knob" on page 11.)
- ② Attach the bracket.
- ③ Screw on the mounting ring.

**Note** Tighten the mounting ring to less than 3.69 ft·lbf.

- ④ Attach the knob.  
(For how to attach the knob see "Attaching the knob" on page 11.)

### ●Panel mount

1. All the mounting holes for the filter regulator for the panel mount installation are  $\phi 1.122$  in.
2. See the following table for the thickness of panels.

Model	FRZB3□	FRZB4□	FRZB5□
Thickness	0.12 or less	0.28 or less	



Using a panel that is thicker than specified may make it impossible to secure the mounting ring or decrease the visibility of the yellow caution ring.

3. Use the following procedure to install with a panel mount.

- ① Remove the knob.  
(For how to remove the knob see "Removing the knob" on page 11.)
- ② Attach the filter regulator to the panel.
- ③ Screw on the mounting ring.



Tighten the mounting ring to less than 3.69 ft·lbf.

- ④ Attach the knob.  
(For how to attach the knob see "Attaching the knob" on page 11.)

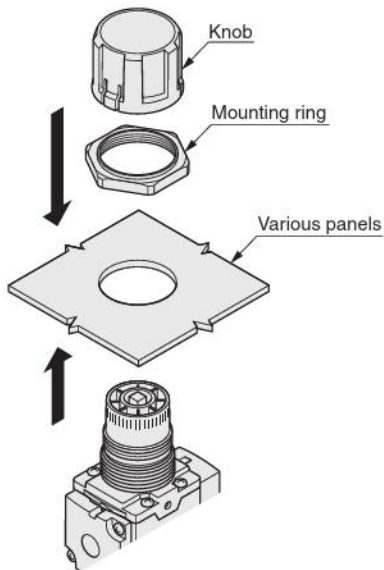

### ●Mounting ring

1. Tighten the mounting ring to less than 3.69 ft·lbf.
2. If you use a tool to tighten the mounting ring, be sure to firmly grip the opposite flats of the mounting ring.



If the mounting ring is not firmly gripped or too much torque is applied to it, component parts may be damaged.

### Operation and maintenance inspections

#### ●Locking and releasing the knob

1. The knobs on the filter regulators use a push lock mechanism. Use the procedure shown in the diagram below to lock and release the knob.

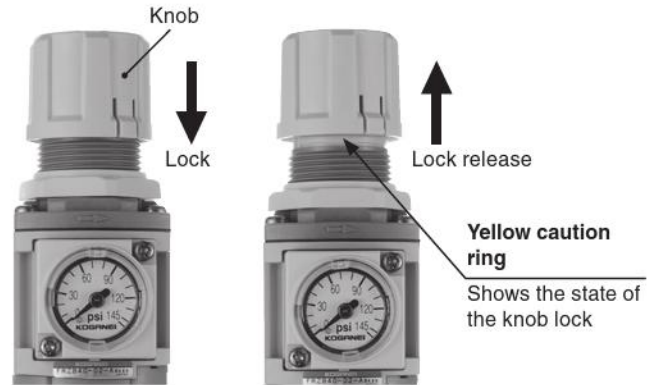

2. Always release the knob lock when regulating the pressure.



Turning the knob while it is locked may damage component parts.

3. Lock the knob after regulating the pressure.

#### ●Pressure regulation

1. Pressure regulation is done as shown in the following diagram by turning the knob in the + direction to increase pressure and in the - direction to reduce it, as shown at the top of the knob.

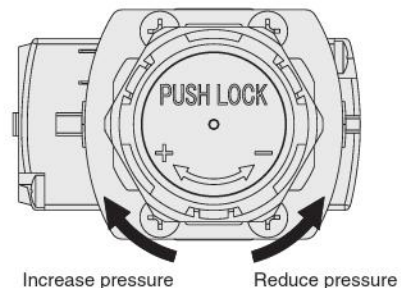

2. Start at a low pressure and match it to the desired set pressure when regulating the pressure. If you exceed the desired pressure, lower the pressure again and start from a low pressure again to set the pressure.



Starting from a high pressure to set the desired pressure causes unstable pressure on the OUT port (secondary) side.

3. Use a pressure gauge to check the pressure on the IN port (primary) side and OUT port (secondary) side while regulating the pressure.

4. It is possible to increase the regulating pressure to exceed the upper limit of the operating pressure range by turning the knob to the upper limit of the + side, but keep the regulated pressure within the operating pressure setting range.



Turning the knob farther than necessary may damage component parts.



## Handling instructions and Precautions (FRZB Filter Regulators)



### Filter regulator (With water and fluids removal functions)

#### ●Removing the knob

Use the following procedure to remove the knob.

- ① Release the knob lock.  
(For how to release the knob lock see "Locking and releasing the knob" on page 10.)
- ② Turn the mounting ring counterclockwise (in the direction of the arrow in the diagram below).
-  Turn the mounting ring until it comes off the threads.
- ③ Pull the mounting ring over in the direction of the knob.
-  The release sleeve of the mounting ring must be pulled up until it spreads the hooks (3 places) on the knob.
- ④ Pull off the knob and the mounting ring together.

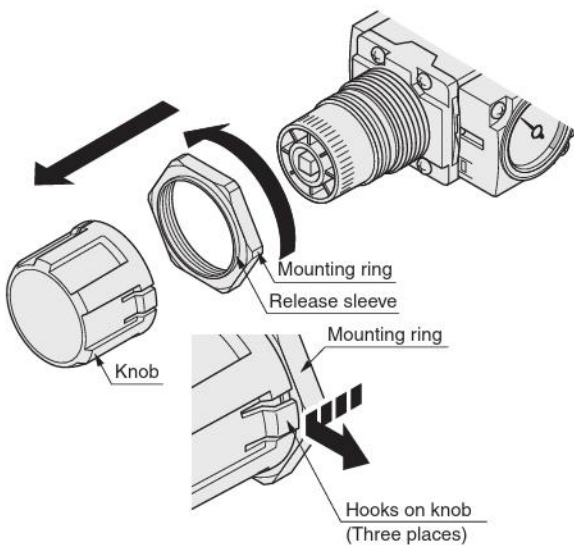

#### ●Attaching the knob

1. Use the following procedure to attach the knob.

- ① Release the pressure of the IN port (primary) side to the atmosphere.
- ② Screw on the mounting ring.
-  Installing the knob before screwing on the mounting ring makes it impossible to attach the mounting ring and makes the knob difficult to remove.
- ③ Press the knob in until the yellow caution ring is not visible.

 Before pressing on the knob, align the square part of the adjusting assembly (refer to the exploded view on page 14) and the square indented portion of the inside of the base of the knob before pressing the knob on, so the knob is easier to press on.

2. Attaching the knob while the filter regulator IN port (primary) side pressure is being applied, may cause a temporary rise in pressure on the OUT port (secondary) side pressure.  
Before attaching the knob, always release pressure on the IN port (primary) side to the atmosphere, because a temporary increase in pressure on the OUT port (secondary) side may occur which may damage equipment or devices on the OUT port (secondary) side or cause a malfunction.

 It may damage the equipment or devices or injure workers or operators.

3. If it is impossible to release the pressure on the IN port (primary) side to the atmosphere, the pressure on the OUT port (secondary) side will rise temporarily, check for any effect it may have had on downstream equipment and devices, and then attach the knob.

#### ●Replacing the □1.181 in. integrated pressure gauge and pressure port plate

1. Be sure to release any pressure in the system before replacing the □1.181 in. integrated pressure gauge or pressure port plate.
2. Use the following procedure to change the □1.181 in. integrated pressure gauge or pressure port plate.

- ① Remove the two small screws.
- ② Remove any metal chips from the female thread hole with compressed air blow.

 If there are any metal chips left, they may break the threads or get on the o-ring and cause an air leak.

- ③ Put the O-ring on the □1.181 in. integrated pressure gauge or pressure port plate.

 Not using an o-ring will result in air leaks.

- ④ Align the groove on the □1.181 in. integrated pressure gauge or pressure port plate with the tongue on the main unit and attach it.

- ⑤ Tighten the two mounting screws to 0.66 to 0.81 ft·lbf.

 If torque exceeding the specifications is applied, the head of the screw or threads may be damaged and cause damage to component parts. Also, if torque below the specifications is used, the screw may come loose and cause an air leak.

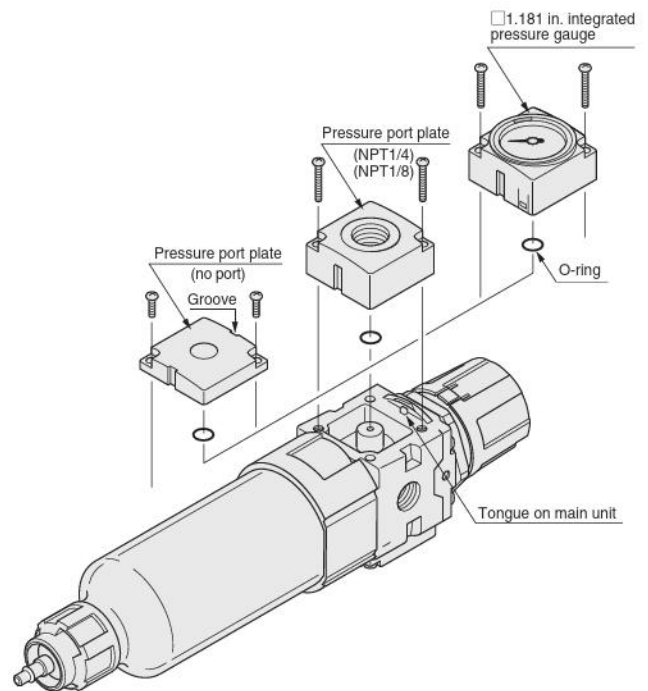

#### ●Drain cock operation

1. Turn the drain cock with your hand.
2. Use the following procedure to operate the drain cock.
  - ① Turn the drain cock in the direction of [O].
  - ② After the moisture (water) and fluid (sediment) has drained out, turn the drain cock in the direction of [S] until it clicks and locks.
3. Do not turn the drain cock more than 100° from the closed position, when you open it.

 Turning the drain cock more than 100° may damage it.

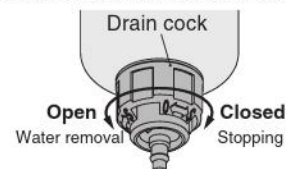

### ●Water and fluids removal

1. If the regulator you are using has no auto drain (-N), be sure to drain the water and fluids before their volume reaches the level shown in the left side diagram below.

 If the volume of water and fluids is greater than that shown in the left side diagram below, the water and fluids removal function of the product is greatly reduced.

2. If the regulator you are using has an auto drain (-A or -C), the water and fluids that collects on the primary side is flushed all at once, do not let it exceed the maximum level as shown in the right side diagram below.

 The auto drain may malfunction if the volume of water and fluids exceeds the maximum level as shown in the left side diagram below.

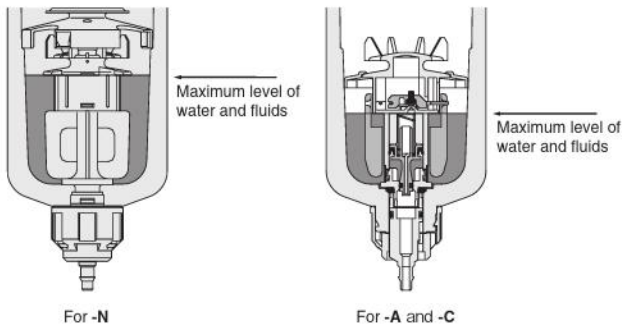

3. See page 15 "Explanation of operation of auto drain system" regarding the auto drain operation principles.
4. A tube with an inner diameter of  $\phi 0.157$  in. [4mm] can be attached to the barbed fitting of the drain cock. Make sure the drain cock is closed (locked) before attaching the tube.
5. Cut the end of the tube to be connected to the barbed fitting of the drain cock straight across, and the barbed fitting must be inserted completely as shown in the diagram. Also, after installing the tube, lightly pull on it to confirm that it does not come off.
6. Do not allow the tube on the barbed fitting of the drain cock to become severely bent or twisted close to the fitting.

 Lateral force may damage the barbed fitting.

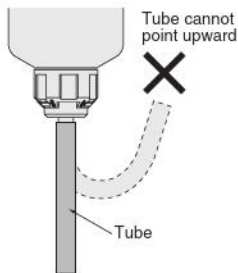

### ●Attaching and removing the bowl assembly

1. Be sure to release any pressure in the system before attaching (or removing) the bowl assembly.
2. Use the procedure shown in the upper right diagram to attach (or remove) the bowl assembly.
3. Squeeze the guard button to attach (or remove) the bowl assembly.

 If there is a bowl guard, it may fall off when you squeeze it.

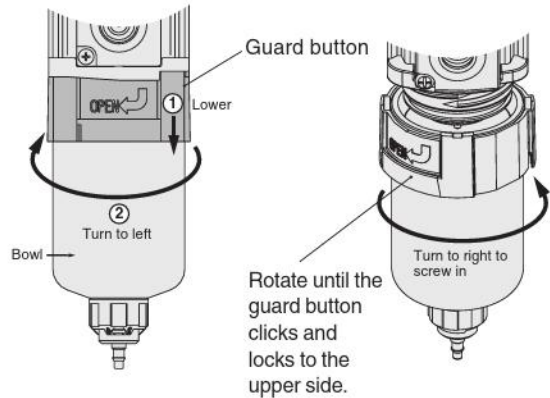

4. When attaching or removing the bowl assembly, move it vertically so you do not touch the internal component parts.

### ●Attaching and removing the bowl guard

1. Be sure to release any pressure in the system before attaching or removing the bowl guard.
2. Use the procedure shown in the diagram below to remove (or attach) the bowl guard.

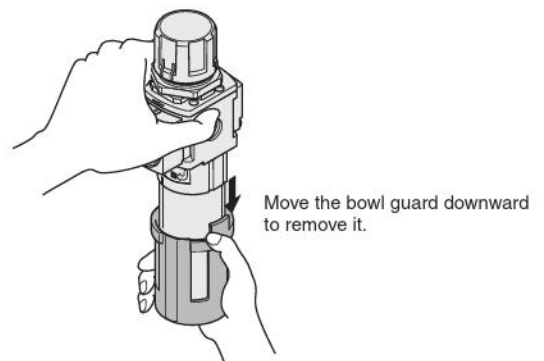
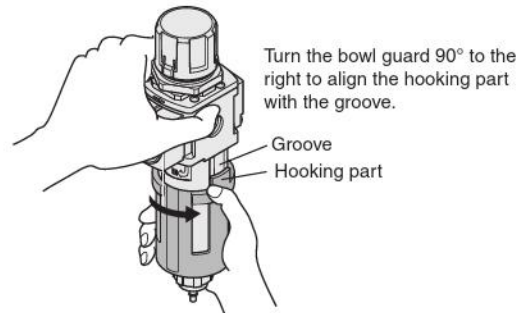
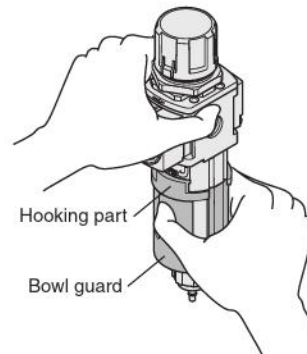

3. Use the reverse of the procedure shown in the diagram above to attach the bowl guard.

## Handling instructions and Precautions (FRZB Filter Regulators)



### Filter regulator (With water and fluids removal functions)

#### ● Installing provided options

1. Be sure to release any pressure in the system before attaching (or removing) the various pressure gauges.
2. When installing the various types of pressure gauges, always apply the wrench on the square or hexagonal part of the piping connections.



Gripping the body of the various pressure gauges to tighten them may damage component parts.

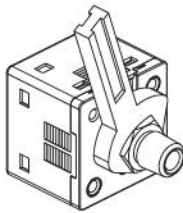

3. Use a tightening torque of 2.21 to 3.69 ft•lbf if the various pressure gauges are mounted on the NPT1/8 or NPT1/4 pressure port plate.



If torque exceeding the specifications is applied, it may damage component parts. Also, if torque below the specifications is used, the screw may come loose and cause an air leak.

4. There is a stopper on the female thread of the NPT1/4 and the NPT1/8 pressure port plates.



Further tightening after the stopper has been reached may damage component parts.

#### ● Replacing the pressure port plate, knob, and mounting ring

1. When replacing the pressure port plate, refer to "Replacing the □1.181 in. integrated pressure gauge and pressure port plate" on page 11.
2. When replacing the knob and mounting ring, refer to "Removing the knob" and "Attaching the knob" on page 11.

#### ● Replacing the seal kit, element, and bowl assembly

1. To replace the seal kit, element, and bowl assembly, remove the filter regulator and do the work on a work table.
2. The o-rings and other sealing materials (except for the diaphragm) of the filter regulator are coated with grease.
3. Contact your nearest Koganei sales office or overseas department if you are considering re-coating the o-rings and other parts with grease.  
Recommended grease: Lithium Soap based No. 2 or equivalent
4. Periodically replace the element in the filter regulator.



The service life of the element varies depending on the quality of air supplied to the IN port (primary) side. If there is a lot of foreign matter in the air supply to the IN port (primary) side, install a pre-filter on the IN port (primary) side or change the element more often. As a guideline, change the element after a year of use.

5. It is not possible to combine a bowl assembly for an FRZB filter regulator (with water and fluids removal function) with FRZ series filter regulators (without water and fluids removal function).



They have different internal component parts, so their specifications do not match.



FRZ Series  
Filter Regulator

(FRZ3□ · FRZ4□ · FRZ5□)

FRZB  
Filter Regulator

(FRZB3□ · FRZB4□ · FRZB5□)

6. Do periodic inspections to look for cracks, scratches, or other deterioration in the clear plastic part of the bowl assembly. If you detect any cracks, scratches, or other deterioration, stop using the regulator and replace the bowl assembly with a new one.



Cracks, scratches, or other deterioration can cause the bowl to break.

7. Replace the bowl assembly with a new one if it becomes dirty or the transparency is significantly reduced. To wash the bowl, use diluted household neutral cleaner to wash it and then rinse it off with water.

See page 16 for details about the chemical resistance of the bowl material.

8. When replacing the seal kit, element, and bowl assembly, be careful not to lose component parts.

9. Refer to page 14 when replacing the seal kit, element, and bowl assembly.



Always assemble the component parts correctly.

## Filter regulator (with moisture removal function) bowl side

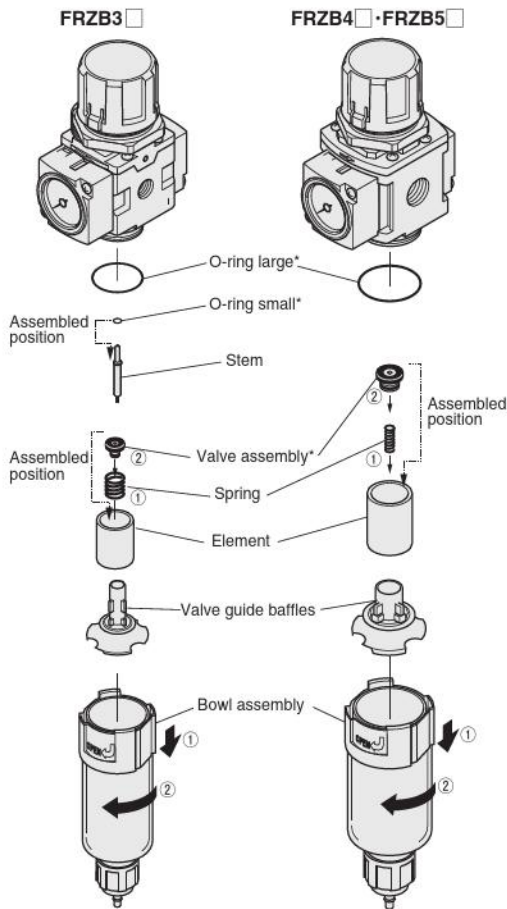

\*Parts in seal kit.



- The product is no longer under warranty if it is disassembled and reassembled.
- Regarding the O-rings in the seal kit: FRZB3 can only use the large and small O-ring, the FRZB4 and FRZB5 can only use the large O-ring, the remaining O-rings are not used.

## Filter regulator knob side

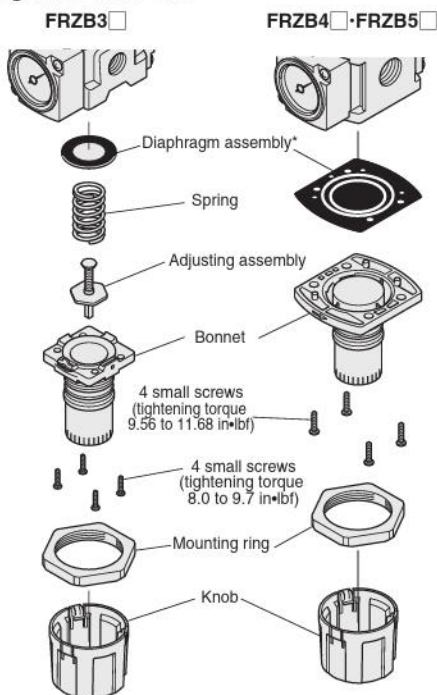

\*Parts in seal kit.



- The product is no longer under warranty if it is disassembled and reassembled.



## □1.181 in. series integrated pressure gauge

### Mounting (installation) and piping

#### ●Mounting (Installation)

Read the Handling Instructions and Precautions for the filter regulator when installing the □1.181 in. integrated pressure gauge to the filter regulator.

### Medium and operating environment

#### ●Surging, vibration, and shock

The □1.181 in. integrated pressure gauge is a precision device. It cannot be used if the medium surges, or external vibration or shock is applied.



- Surges in the medium, external vibrations or shocks may result in damage to component parts.

### Operation and maintenance inspections

#### ●Adjusting the range of the set pressure

1. Use the procedure below to adjust the range of the set pressure (the green portion).

- ① Adjust the lower limit of the range of the set pressure by rotating the protrusions (2 places) clockwise with your hand.
- ② Adjust the upper limit of the range of the set pressure by rotating the protrusions (2 places) counter clockwise with your hand.



- Adjusting the range of the set pressure with a tool may damage component parts.

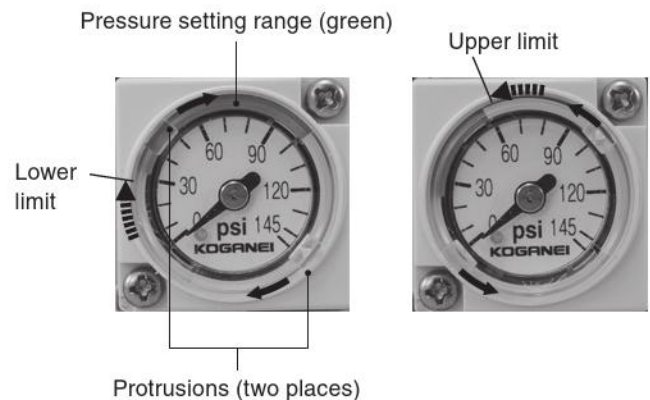

# Handling instructions and Precautions (FRZB Filter Regulators)

## ● Explanation of operation of auto drain system

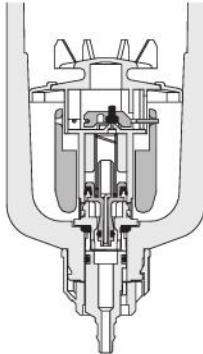
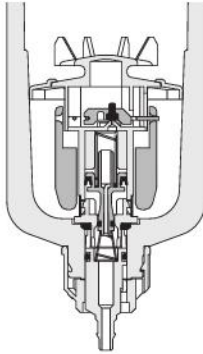
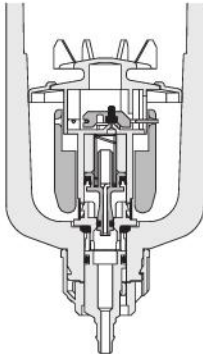
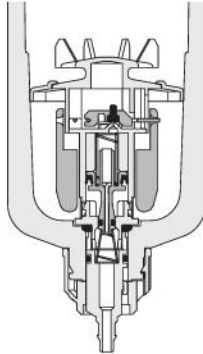
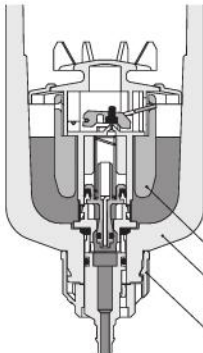
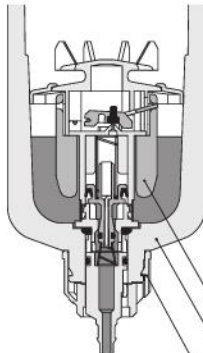
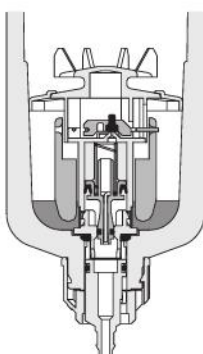
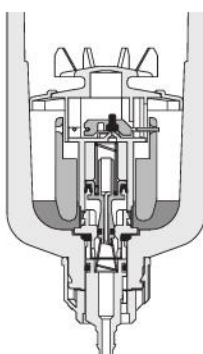
State	Type	NO type	NC type
Not pressurized		 <p>When unpressurized, the liquid outlet opens and the liquid drains naturally.</p> <p>Open</p>	 <p>When unpressurized, the liquid outlet closes and the liquid cannot drain.</p> <p>Cautions: The liquid does not drain when unpressurized, if there is a lot of liquid even in an unpressurized (low pressure) condition, it may be necessary to drain the liquid by hand.</p> <p>Closed</p>
		 <p>Air and liquid will be discharged from the liquid outlet until the pressure exceeds the minimum operating pressure (22 psi). The air and liquid will stop after stored pressure exceeds the minimum operating pressure.</p> <p>Cautions: A compressor with a small output may not reach full pressure, and there may be exhaust air until the minimum operating pressure is exceeded.</p> <p>Closed</p>	 <p>In the same way, when unpressurized, the liquid outlet closes and the liquid cannot drain.</p> <p>Closed</p>
Draining the liquid		 <p>When the level of liquid in the bowl reaches a specified level, the float lifts and the liquid automatically drains.</p> <p>Cautions: The liquid can be drained manually by turning the drain knob to the left. See page 11 for details.</p> <p>Float Bowl Drain knob</p> <p>Open</p>	 <p>When the level of liquid in the bowl reaches a specified level, the float lifts and the liquid automatically drains.</p> <p>Note 1: Supply pressure is needed to operate the auto drain. A minimum of 22 psi is needed for the supply pressure.</p> <p>Note 2: The liquid can be drained manually by turning the drain knob to the left. See page 11 for details.</p> <p>Float Bowl Drain knob</p> <p>Open</p>
		 <p>When the liquid drains, the float lowers and the liquid outlet closes, and the liquid stops draining.</p> <p>Closed</p>	 <p>When the liquid drains, the float lowers and the liquid outlet closes, and the liquid stops draining.</p> <p>Closed</p>

## Handling instructions and Precautions

### ● Principles of water and fluids removal

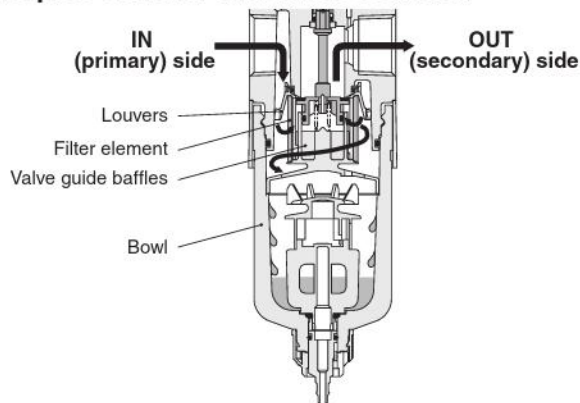

- ① Louvers create a swirling current in the air that enters through the IN port (primary) to separate the water and fluids from the air.
- ② The separated water and fluids passes through the gaps in the valve guide baffles and collects in the bowl.
- ③ The air, from which the water and fluids have been separated, passes through the filter element to the OUT port (secondary).

### Reference data

#### ● About the chemical resistance of polycarbonate

The chemicals in the following table degrade polycarbonate. Because of this, they may damage the bowl of the filter regulator or the front cover of the pressure gauge and cause an accident. The products cannot be used in locations where the chemicals in the following table are present in the compressed air, ambient air, or on surfaces. This does not mean that polycarbonate is chemically resistant to all chemicals not listed below.

Type	Classification	Chemical name	Application example
Inorganic compound	Acid	Hydrochloric acid, sulfuric acid, nitric acid, fluorine, phosphoric acid, chromic acid	Acid cleaning for metals, acid degreasing, and coating processing
	Alkali	Caustic soda, caustic potash, hydrated lime, ammonia water, sodium carbonate	Alkaline degreasing of metals
	Inorganic salt	Sodium sulfide, potassium nitrate, potassium dichromate, sodium nitrate	Dyes, rust inhibitor
Organic compounds	Aromatic hydrocarbons	Benzene, toluene, xylene, ethyl benzene, styrene	Paint thinner (Benzene, toluene, xylene)
	Chlorinated aliphatic hydrocarbons	Methyl chloride, ethylene chloride, methylene chloride, acetylene dichloride, chloroform, trichlene, tetrachloroethylene, carbon tetrachloride	Organic solvents for metal cleaning (trichlene, tetrachloroethylene, carbon tetrachloride)
	Chlorinated aromatic hydrocarbons	Chlorobenzene, dichlorobenzene, hexachloride (BHC)	Agricultural chemicals
	Petroleum components	Solvent, naphtha, gasoline	Fuel
	Alcohol	Methyl alcohol, ethyl alcohol, cyclohexanol, benzyl alcohol	Anti-freezing agents
	Phenol	Carbolic acid, cresol, naphthol	Antiseptic solutions
	Ether	Methyl ether, methyl ethyl ether, ethyl ether	Brake fluid additive, detergent
	Ketones	Acetone, methyl ethyl ketone, cyclohexane, acetophenone	Cleaning solutions
	Carboxylic acid	Formic acid, acetic acid, butyl acid, acrylic acid, oxalic acid, phthalic acid	Dyes, aluminum processing solution (oxalic acid), paint medium (phthalic acid)
	Phthalic acid ester	Dimethyl phthalate (DMP), diethyl phthalate (DEP), dibutyl phthalate (DBP), dioctyl phthalate (DOP)	Lubricants, synthetic hydraulic fluids, corrosion resistant additives, synthetic resin plasticizer
	Oxyacid	Glycolic acid, lactic acid, malic acid, citric acid, tartaric acid	Food preservatives, acidulant
	Nitro compounds	Nitromethane, nitroethane, nitroethylene, nitrobenzene	Paint solvent, explosives
	Amine	Methylamine, dioctylamine, ethylamine, aniline, acetanilide	Brake fluid additive
	Nitrile	Acetonitrile, acrylonitrile, benzonitrile	Nitrile rubber materials

# Filter regulator

FRZB30-F11·FRZB31-F11·FRZB32-F11  
FRZB40-F11·FRZB41-F11  
FRZB50-F11·FRZB51-F11



## Symbol

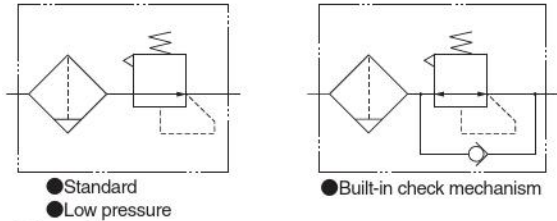

## Specifications

Item	Model	Standard	FRZB30-F11	FRZB40-F11	FRZB50-F11
		Low pressure	FRZB31-F11	FRZB41-F11	FRZB51-F11
		Built-in check mechanism	FRZB32-F11		
Medium			Air		
Port size			M5×0.8mm, NPT1/8, NPT1/4	NPT1/8, NPT1/4, NPT3/8	NPT1/4, NPT3/8, NPT1/2
Maximum operating pressure	psi		145		
Proof pressure	psi		218		
Operating temperature range (atmosphere and medium)	°F		41 to 140 (non-condensation)		
Filtration	µm		5		
Regulation method			Direct operation type and relief type	Internal pilot type and relief type	
Pressure setting range	psi	Standard/built-in check mechanism	7 to 123		
		Low pressure	7 to 58		
Relief start pressure	psi		Set pressure +7 or less		
Air consumption <sup>Note 1</sup>	ft <sup>3</sup> /min (SCFM)		—	0.18 or less	
Water storage capacity (for -N)	in <sup>3</sup>		0.79	0.98	1.65
Materials of major parts	Body	Die cast aluminum alloy			
	Bonnet and adapter	Polyacetal			
	Diaphragm	Base fabric + synthetic rubber			
	Bowl	Polycarbonate			
	Filter element	Non-woven fabric			
	Bracket	Steel plate (electroless nickel plated)			
Mass (for standard specifications and largest port size)	lbf		0.44	0.53	0.73
Standard equipment			Mounting ring		
Options <sup>Note 2, Note 3</sup>			Auto drain (NO or NC), bowl guard (plastic assembled), □1.181 in. integrated pressure gauge (assembled), other pressure gauges (included parts), brackets (included parts)		

Note 1: Maximum value of specified range. Air consumption varies depending on the relationship of the primary pressure and the secondary pressure.

2: Supply pressure greater than 22 psi is needed to select the optional auto drain (supply pressure is needed to operate the auto drain).

3: Refer to the order codes and the specifications for each product starting on page 24 for details on the various types of options.

## Order codes

**FRZB** [ ] - **F11** - [ ] - [ ] - [ ] - [ ] - [ ]

**NPT thread specifications**

**Model of body**    **Port size**

30	M5	NPT1/8	01	02		
40	M5		01	02	03	Standard
50				02	03	
31	M5		01	02		Low pressure
41			01	02	03	
51				02	03	Built-in check mechanism
32	M5		01	02		

**Bowl guard specifications**

Blank — No bowl guard  
PG — With bowl guard

**Drain cock specifications**

A — Auto drain type, drain cock NO type  
C — Auto drain type, drain cock NC type  
N — Drain cock with fitting

**Bracket**

Blank — No bracket  
B — With bracket

**Pressure gauge specifications**

Blank — No pressure gauge (pressure gauge connection port NPT1/4)  
GP1 — No pressure gauge (pressure gauge connection port NPT1/8)  
GN — No pressure gauge (No pressure gauge connection port)  
G1C — 145 psi specifications, □1.181 in. integrated pressure gauge  
G4C — 58 psi specifications, □1.181 in. integrated pressure gauge  
G1 — 145 psi specifications, φ1.575 in. pressure gauge  
G3 — 44 psi specifications, φ1.575 in. pressure gauge  
G1S — 145 psi specifications, φ1.575 in. stainless Bourdon tube pressure gauge  
G3S — 44 psi specifications, φ1.575 in. stainless Bourdon tube pressure gauge  
GS6 — 145 psi specifications, digital pressure switch  
GS1A — 145 psi specifications, □1.969 in. pressure gauge with built-in switch Lead wire for 24 VDC  
GS1B — 145 psi specifications, □1.969 in. pressure gauge with built-in switch Lead wire for 100 VAC, 200 VAC  
GS1C — 145 psi specifications, □1.969 in. pressure gauge with built-in switch With DIN type connector for 24 VDC  
GS1D — 145 psi specifications, □1.969 in. pressure gauge with built-in switch With DIN type connector for 100 VAC, 200 VAC

Note: Refer to order codes and dimensions on page 24 to 31 for information about the specifications for pressure gauges, digital pressure switches, pressure gauges with built-in pressure switches, and purchasing individual parts.

**FRZB Filter Regulator**

## Order codes

### ● Order codes for brackets only

8Z-BK



\* Interchangeable brackets (compatible with multi-series FR15□, FR30□, and FR60□ filter regulators)

8Z-BK□

Body size

30 — FR15□ → FRZB3□ compatible

40 — FR30□ → FRZB4□ compatible

50 — FR60□ → FRZB5□ compatible



### ● Parts for maintenance

#### ● Bowl assembly

BA-FRZB□-F11-□-□

Body size

30 — For FRZB3□

40 — For FRZB4□

50 — For FRZB5□

Drain cock specifications

A — Auto drain type, drain cock NO type

C — Auto drain type, drain cock NC type

N — Drain cock with fitting

Bowl guard specifications

Blank — No bowl guard

PG — With bowl guard



Auto drain type  
NO type  
NC type



Drain cock  
with fitting



With bowl  
guard

#### ● Element

E-□ZB

Body size

30 — For FRZB3□

40 — For FRZB4□

50 — For FRZB5□



#### ● Pressure port plate

P-FRZ (without pressure gauge connection port)

1 O-ring and 2  
small screws  
included



GP-FRZ□-F11 (with pressure gauge connection port)

Port size

Blank — NPT1/4

1 — NPT1/8



1 O-ring and 2  
small screws  
included

#### ● Seal kit (various O-rings, 1 valve assembly, and 1 diaphragm assembly)

SRK-FRZ□

Body size

30 — For FRZ3□

40 — For FRZ4□

50 — For FRZ5□

#### ● Knob

H-FRZ



#### ● Mounting ring

R-FRZ



Refer to "Replacing the seal kit, element, and bowl assembly" on page 18 for the component parts of the seal kit.

## Inner construction

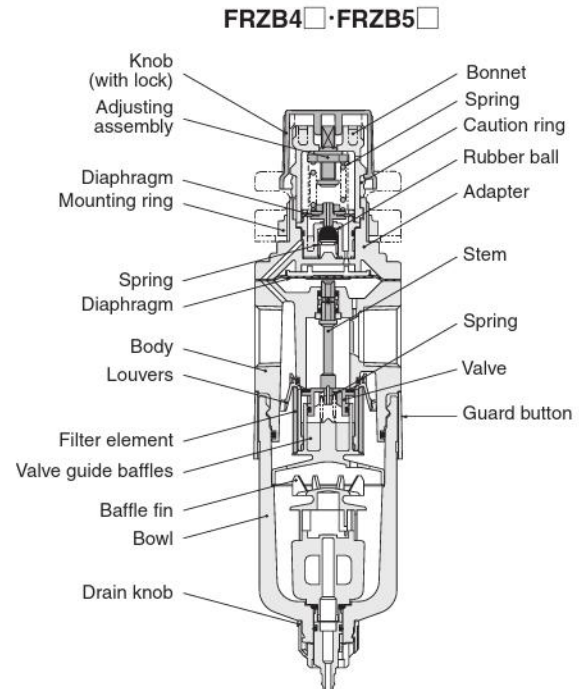
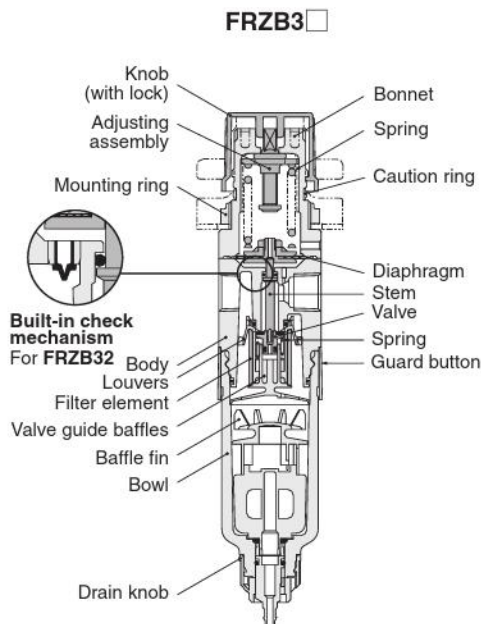

# Flow rate characteristics

## Standard and built-in check mechanism

**FRZB30-F11-M5**  
**FRZB32-F11-M5**

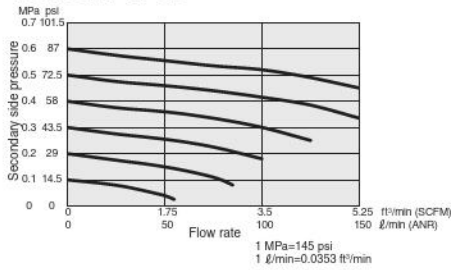

**FRZB40-F11-01**

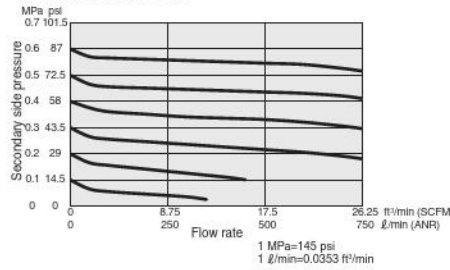

**FRZB50-F11-02**

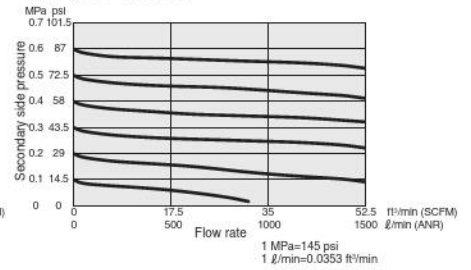

**FRZB30-F11-01**  
**FRZB32-F11-01**

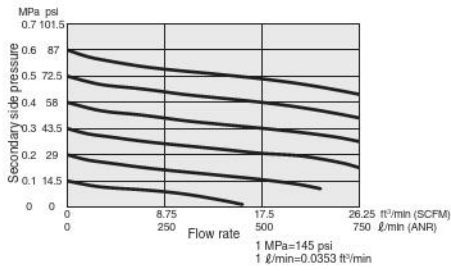

**FRZB40-F11-02**

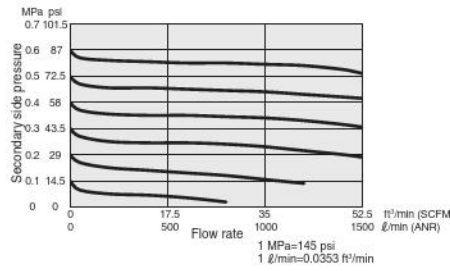

**FRZB50-F11-03**

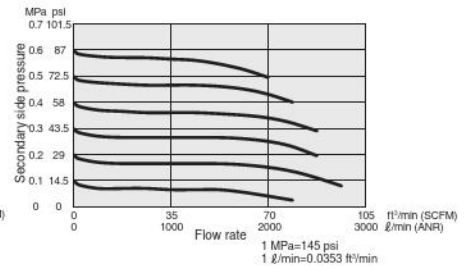

**FRZB30-F11-02**  
**FRZB32-F11-02**

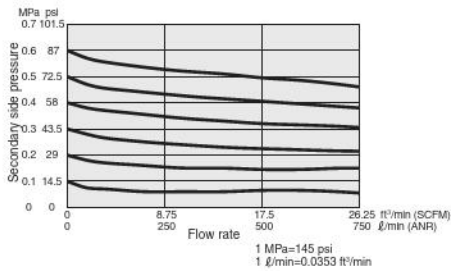

**FRZB40-F11-03**

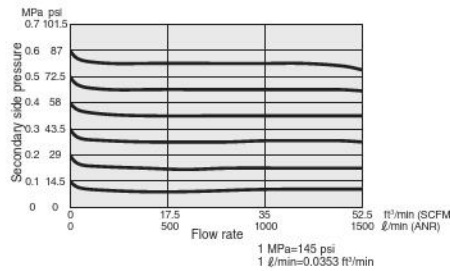

**FRZB50-F11-04**

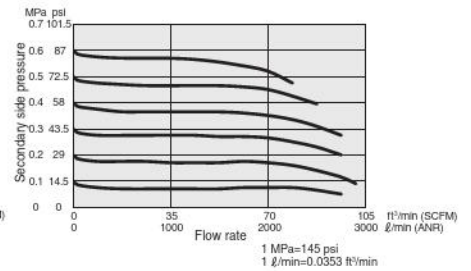

Remarks: Graphs show flow rate characteristics at 102 psi constant pressure on the primary side.

# Pressure characteristics

## Standard and built-in check mechanism

**FRZB30-F11**  
**FRZB32-F11**

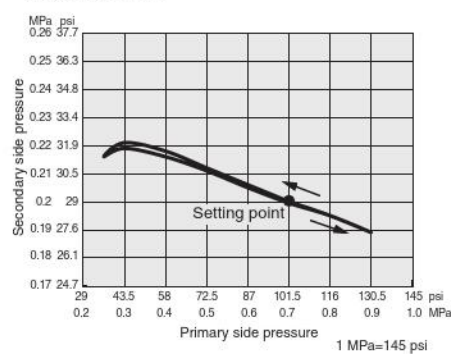

**FRZB40-F11**

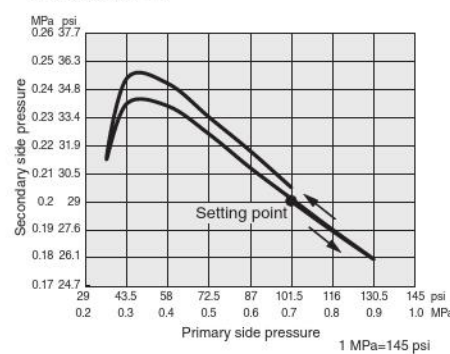

**FRZB50-F11**

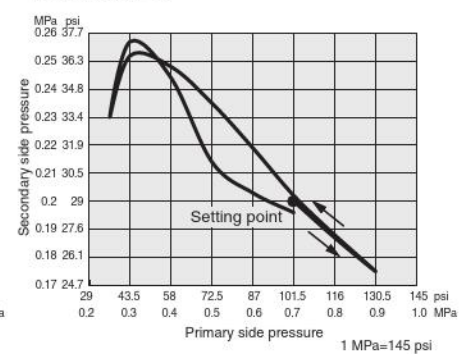

**Filter regulator dimensions in.**

- FRZB30-F11
- FRZB31-F11
- FRZB32-F11

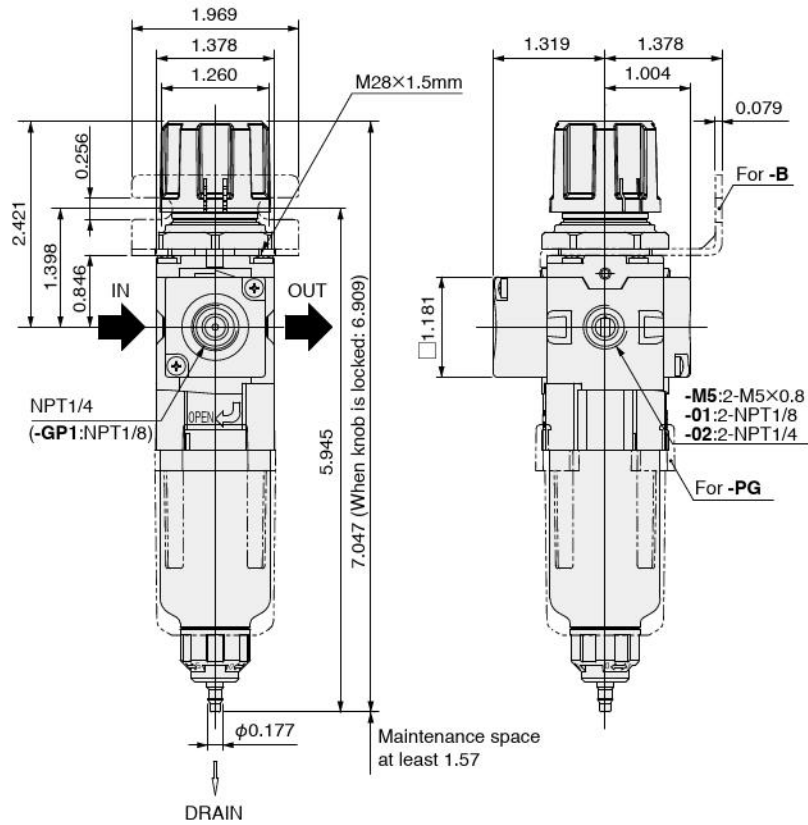

● Pressure gauge options

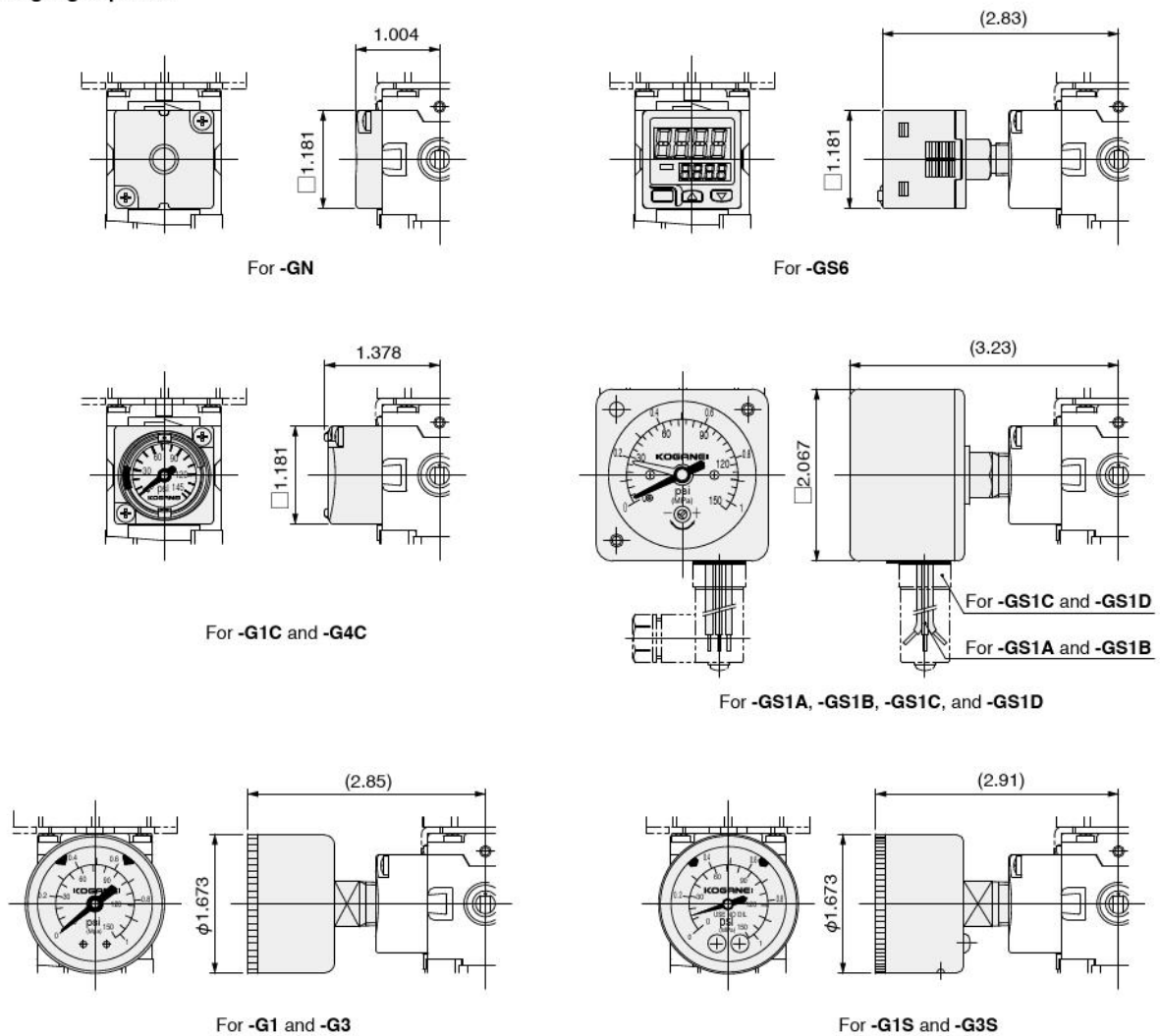

**Filter regulator dimensions in.**

- FRZB40-F11
- FRZB41-F11

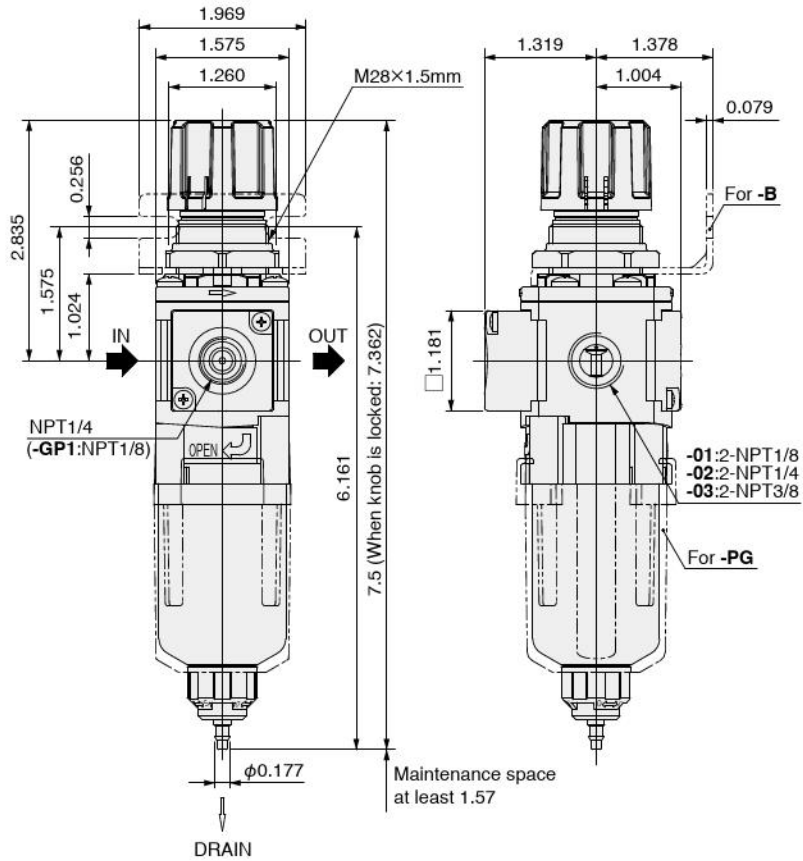

● Pressure gauge options

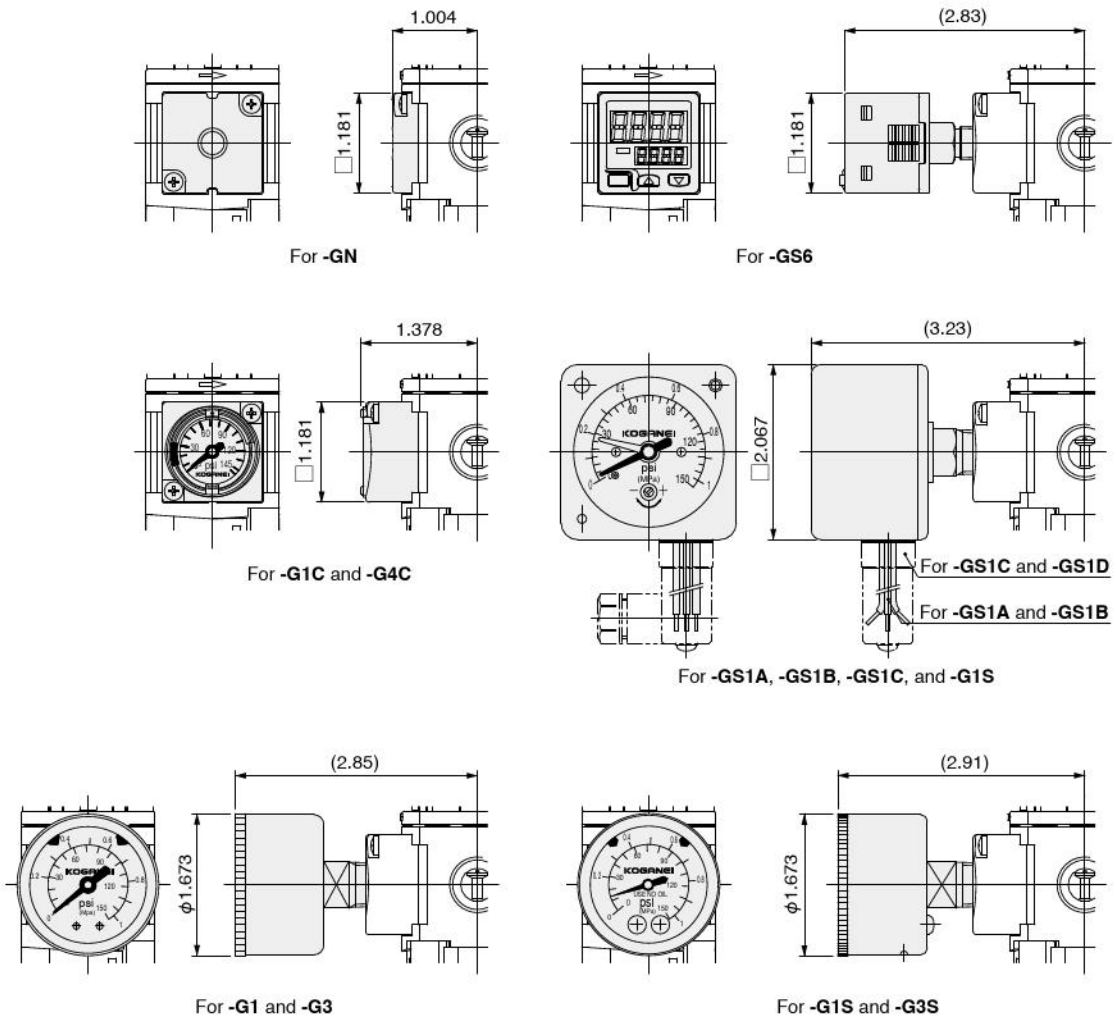

● FRZB50-F11  
● FRZB51-F11

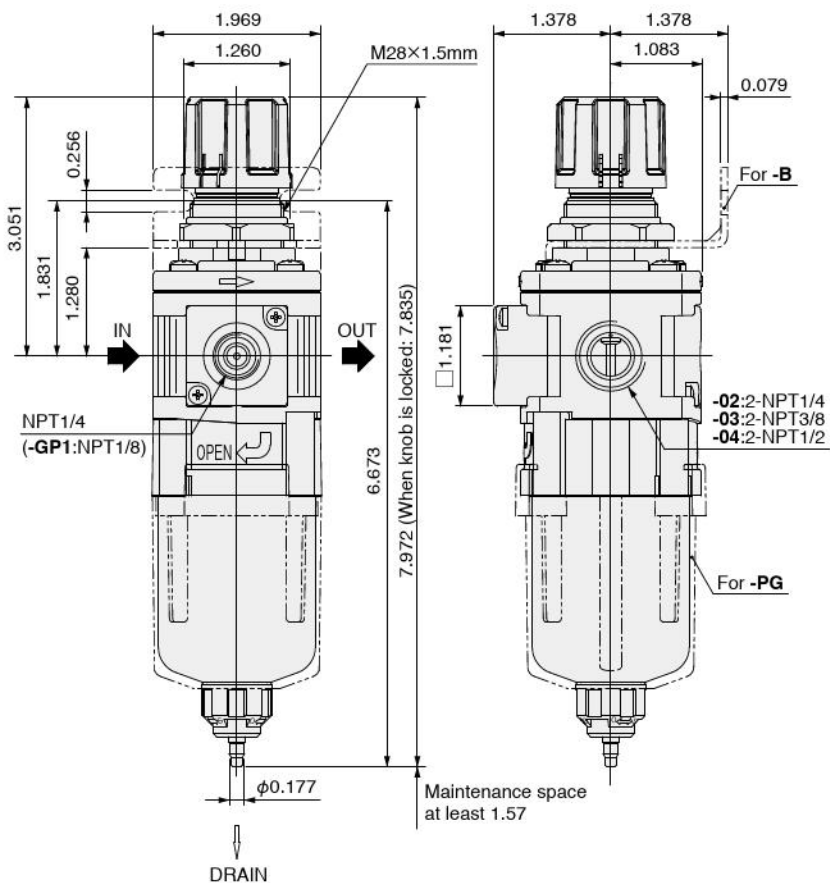

● Pressure gauge options

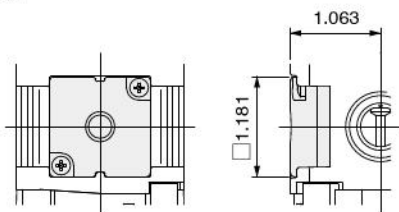

For -GN

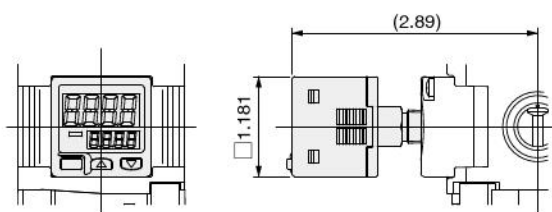

For -GS6

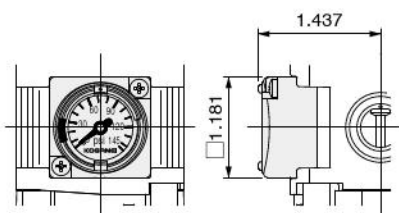

For -G1C and -G4C

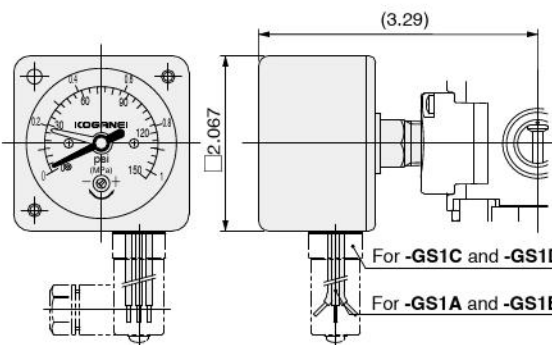

For -GS1A, -GS1B, -GS1C, and -GS1D

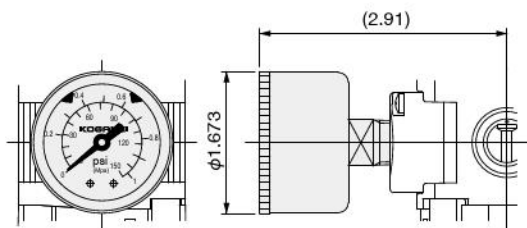

For -G1 and -G3

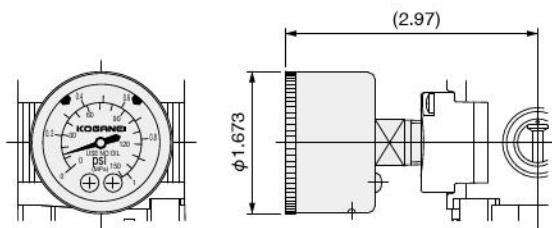

For -G1S and -G3S

# Bracket



## Bracket model and applicable devices

### For filter regulator

Applicable model	Bracket model	Remarks
Filter regulator FRZB3□, FRZB4□, FRZB5□	8Z-BK	Option to support the product body

Materials of major parts: Steel plate (electroless nickel plated)

### Interchangeable bracket

Compatible models		Bracket model	Remarks
FRZB Filter Regulator	Multi-series		
FRZB3□	FR15□	8Z-BK30	Supports the product body, sold separately
FRZB4□	FR30□	8Z-BK40	
FRZB5□	FR60□	8Z-BK50	

Materials of major parts: Steel plate (electroless nickel plated)

## Bracket dimensions in.

### For filter regulator

#### 8Z-BK

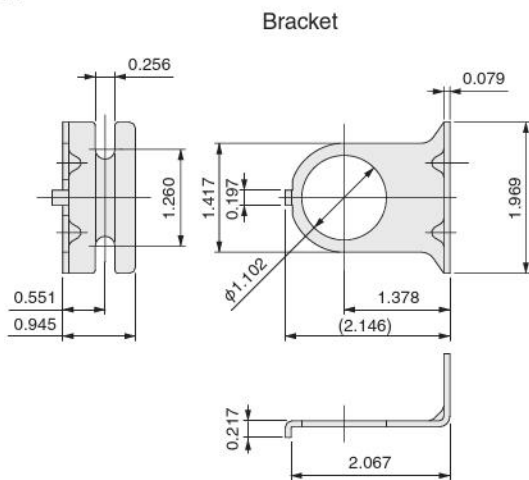

### Interchangeable bracket

#### 8Z-BK30

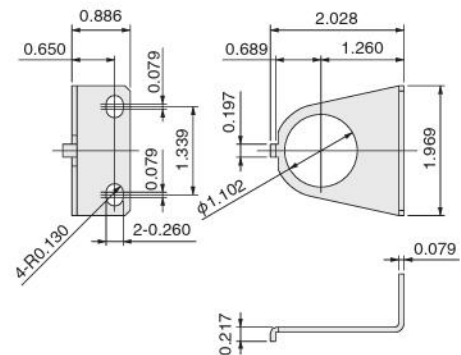

#### 8Z-BK40

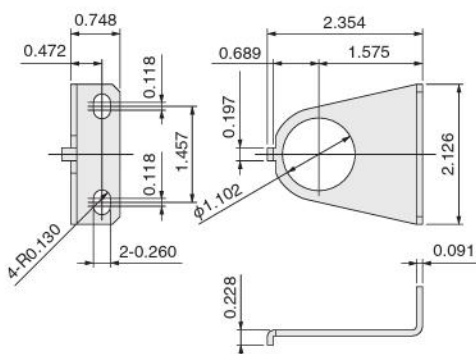

#### 8Z-BK50

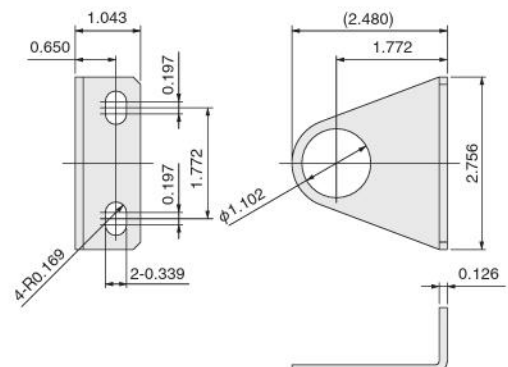

# 1.181 in. series integrated pressure gauge

G1C-30-F11-G4C-30-F11



● 1.181 in. integrated pressure gauge for FRZB filter regulator.

## Symbol



## Order codes

**G** **C** - **30** - **F11**

NPT thread specifications

Outside dimensions

30 — Outside dimensions

1.181 in.

Pressure indicator range

1 — Standard specifications 145 psi

4 — Low pressure specifications 58 psi

Pressure gauge

## Specifications

Item	Model	G1C-30-F11	G4C-30-F11
Medium		Air	
Connection method		O-ring seal, M3x0.5mm (secured by 2 screws)	
Maximum operating pressure <sup>Note</sup>	psi	145	58
Operating temperature range (atmosphere and medium)	°F	41 to 140 (non-condensation)	
Pressure indicator range	psi	0 to 145	0 to 58
Display zone movable range	psi	0 to 145	0 to 58
Display zone maximum set range	psi	72.5	29
Accuracy (for atmosphere and medium at 41 to 95°F)		F.S.±4%	F.S.±6%
Materials of major parts	Case	Polybutylene terephthalate	
	Front cover	Polycarbonate	
	Bourdon tube	Brass	
Mass	oz	1.06	
Applicable models		FRZB3□-F11, FRZB4□-F11, FRZB5□-F11	

Note: Do not supply pressure that exceeds the maximum operating pressure to the 1.181 in. integrated pressure gauge. Doing so may damage the product or reduce its performance and service life.

## Pressure gauge dimensions in.

### G1C-30-F11

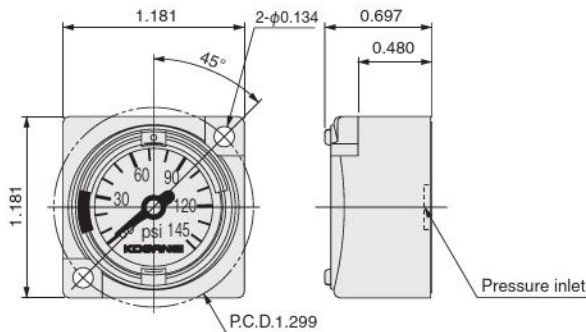

2 phillips head self-tapping screws and 1 O-ring included

### G4C-30-F11

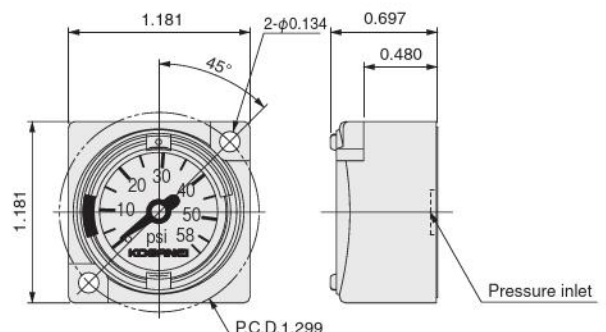

2 phillips head self-tapping screws and 1 O-ring included

Refer to page 14 regarding the handling instructions and precautions for the 1.181 in. integrated pressure gauge.

# Pressure gauge

G1-40-F11·G3-40-F11

## Symbol



## Order codes

G   - 40 - F11

NPT thread specifications

Outside dimensions

40 — Outside diameter  
1.575 in.

Pressure indicator range

1 — Standard specifications 145 psi

3 — Low pressure specifications 43.5 psi

Pressure gauge

## Specifications

Item	Model	G1-40-F11	G3-40-F11
Medium		Air	
Port size		NPT1/4 (M5×0.8mm)	
Pressure indicator range	psi	0 to 145	0 to 43.5
Accuracy		F.S. ±3%	
Maximum operating pressure	psi	134.9	36.3
Operating temperature range (atmosphere and medium)	°F	41 to 140 (non-condensation)	
Mass	oz	3.17	
Materials	Case	ABS	
	Connection port thread	Brass	
	Bourdon tube	Brass	

## Pressure gauge dimensions in.

G1-40-F11

G3-40-F11

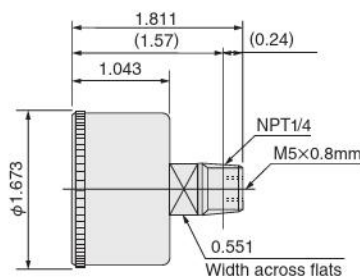
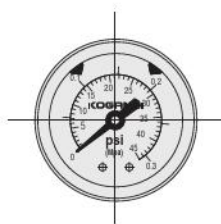
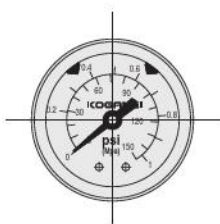

## Handling instructions and precautions



The pressure gauge is a precision measuring device. Be careful of impacts and vibrations.

### Mounting and piping

During mounting and piping operations, do not grab the pressure gauge body to tighten. For tightening, always use a wrench on the piping connection port's square portion. Use a tightening torque of 2.21 to 3.69 ft·lbf when the pressure gauges are mounted on the pressure port plate with NPT1/4.

### Preset marker

You can set the preset marker. Rotate the cover ring to first set the low pressure and then set the high pressure.

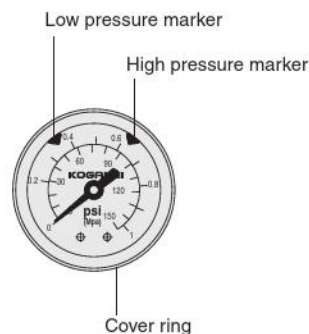

# Pressure gauge

G1S-40-F11·G3S-40-F11

●Stainless steel Bourdon tube pressure gauge.

## Symbol



## Order codes

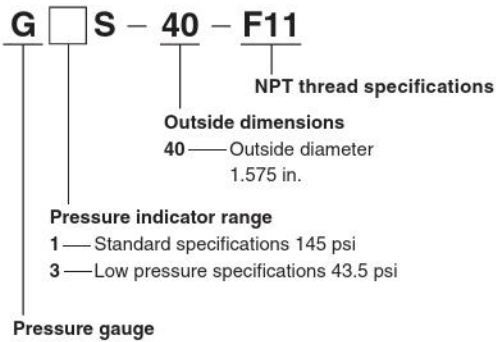

## Specifications

Item	Model	G1S-40-F11	G3S-40-F11
Medium		Air, N <sub>2</sub> , O <sub>2</sub> , CO <sub>2</sub> , He, Ar	
Port size		NPT1/4	
Pressure indicator range	psi	0 to 145	0 to 43.5
Accuracy		F.S. ±2.5%	
Maximum operating pressure	psi	134.9	36.3
Operating temperature range	°F	41 to 140 (non-condensation)	
Mass	oz	3.21	

## Materials

Name	Materials
Case	SPCC (painted black)
Connection port thread	SUS316
Bourdon tube	SUS316
Clear cover	Plastic (PC)

## Pressure gauge dimensions in.

### ●G1S-40-F11

Standard specifications  
145 psi

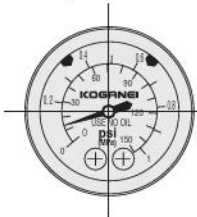

### ●G3S-40-F11

Low pressure specifications  
43.5 psi

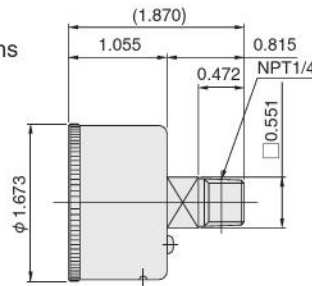

## Handling instructions and precautions



**Note** The pressure gauge is a precision measuring device. Be careful of impacts and vibrations.

### Mounting and piping

During mounting and piping operations, do not grab the pressure gauge body to tighten. For tightening, always use a wrench on the piping connection port's square portion. Use a tightening torque of 2.21 to 3.69 ft•lbf when the pressure gauges are mounted on the pressure port plate with NPT1/4.

### Preset marker

You can set the preset marker. Rotate the cover ring to first set the low pressure and then set the high pressure.

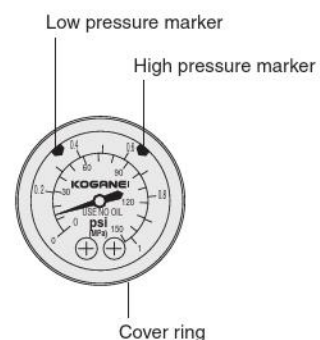

# Digital pressure switch

GS-620-3W



## Specifications

Item	Type	Standard
	Model	High-pressure type <b>GS620-3W</b>
Indication of pressure		Gauge pressure
Rated pressure range		-14.5 to +145 psi
Pressure setting range		-14.5 to +145 psi
Proof pressure		218 psi
Applicable media		Non-corrosive gas
Supply voltage		12 to 24 VDC $\pm 10\%$ , ripple P-P 10% or less
Power consumption		Normal operation: 720 mW or less (current consumption 30 mA or less at 24 V supply voltage) ECO mode (at STD): 480 mW or less (current consumption 20 mA or less at 24 V supply voltage), ECO mode (at FULL): 360 mW or less (current consumption 15 mA or less at 24 V supply voltage)
Comparative output		PNP transistor open collector <ul style="list-style-type: none"> <li>• Maximum inflowing current: 100 mA</li> <li>• Applied voltage: 30 VDC or less (between comparative output and 0 V)</li> <li>• Residual voltage: 2 V or less (at inflowing current 100 mA, however, cable must be less than 78.7 in. long)</li> </ul>
	Output operation	Selectable, either NO or NC by key operation
	Output mode	EASY mode/hysteresis mode/window comparator mode
	Response differential (hysteresis)	Minimum 1 digit (variable)
	Repeatability	$\pm 0.2\%$ F.S. (within $\pm 2$ digits)
	Response time	2.5 ms, 5 ms, 10 ms, 25 ms, 50 ms, 100 ms, 250 ms, 500 ms, 1000 ms, 5000 ms, selectable by key operation
	Short circuit protection	Equipped
Display		4 digits + 4 digits, 3-color LCD display (display refresh rate: 250 ms, 500 ms, 1000 ms, selectable by key operation)
	Displayed pressure range	-14.5 to +145 psi
Indicators		Orange LED (comparative output 1 operation indicator, comparative output 2 operation indicator: Lights up when comparative output is ON)
Environmental resistance	Protective structure	IP40 (IEC)
	Ambient temperature	14 to 122 °F, in storage: 14 to 140 °F
	Ambient humidity	35 to 85% RH (however, no condensation or freezing), in storage: 35 to 85% RH
	Dielectric strength	1000 VAC for one minute (between electrical connection part and case)
	Insulation resistance	50 M $\Omega$ or over at 500 VDC meggers (between electrical connection part and case)
	Vibration resistance	Endurance 10 to 500 Hz, total amplitude 0.118 in., 2 hours in each of the XYZ directions (with panel mounting: Endurance 10 to 150 Hz, total amplitude 0.0295 in., 2 hours in each of the XYZ directions)
	Shock resistance	Endurance 328 ft/s <sup>2</sup> (about 10 G), 3 times in each of the XYZ directions
Thermal characteristics		Within $\pm 1\%$ F.S. (reference at +68 °F)
Pressure port		M5×0.8mm female thread and NPT1/8 male thread
Materials		Case: PBT (fiberglass reinforced), LCD display: Acrylic, pressure port: SUS303, mounting thread: brass (nickel plated), switches: silicon rubber
Connection method		Connectors
Wire length		Up to 328 ft long on a cable of 0.00047 in <sup>2</sup> . or larger
Mass		Approximately 1.41 oz
Accessories		78.7 in. cable with connector: 1 pc.

Note: Unspecified measuring conditions use an ambient temperature of + 68 °F.

## Handling instructions and Precautions



### General precautions

#### Wiring

1. Always shut off the power supply before performing wiring work.
2. Confirm that the power source does not fluctuate over the rated power.
3. Be sure to ground to frame ground (F.G.) terminal of the power source when using a commercially available switching regulator.
4. When using equipment that could be sources of electric noise (such as switching regulators, inverter motors, etc.) near the pressure switch installation, be sure to ground the equipment's frame ground (F.G.) terminal.
5. Avoid wiring parallel to high voltage lines or power lines, or inside the same wiring conduits. Induction could cause erratic operation.
6. Incorrect wiring could cause malfunctions.
7. After completing wiring work, check to make sure that all connections are correct.

#### Connections

Do not apply stress directly to the connectors or to the wires coming out of the connectors.

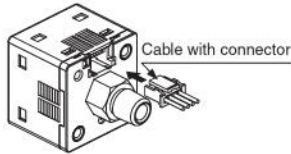

#### Mounting and piping

Use a tightening torque of 2.21 to 3.69 ft·lbf when mounting on the pressure port plate with NPT1/8. For details, see page 18 "Installing provided options".

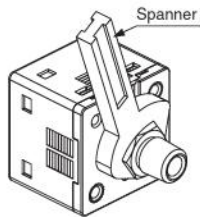

#### Other precautions

1. The GS6 series is for use with non-corrosive gases. Do not use with liquids or with corrosive gases.
2. Use within the rated pressure range.
3. Do not apply pressure in excess of the proof pressure. Doing so could damage the diaphragm and cause malfunctions.
4. Avoid using the product immediately after the power is turned on, while it is in a transitory state (about 0.5 sec).
5. Avoid use in very humid or dusty locations.
6. Be careful that the product does not come in direct contact with organic solvents, such as thinner, or water, oil, or grease.
7. Do not put pins or anything else in the pressure port. Doing so could damage the diaphragm and cause malfunctions.
8. Do not operate the keys with a pin or similar sharp object.

#### About the RUN mode

This is the normal operating mode.

Setting items	Description
Threshold value setting	You can directly change the ON/OFF threshold value by just pressing the UP key or DOWN key.
Zero adjust function	This function forces the pressure value to zero when the pressure port is open to the atmosphere.
Key lock function	This function prevents key operations.
Peak & bottom hold function	This function shows the peak and bottom values of changes in the pressure. The peak value appears in the main display, the bottom value appears in the sub display.

#### About the menu setting mode

1. While in the RUN mode, press and hold the mode switch key for 2 seconds to switch to the menu setting mode.
2. Press and hold the mode switch key while doing settings to switch to the RUN mode. When this is done, the items you changed are set.

Setting items	Description
Comparative output 1 output mode settings	Sets the output mode of comparative output 1.
Comparative output 2 output mode settings	Sets the output mode of comparative output 2.
NO/NC switching	Sets either normally open (NO) or normally closed (NC).
Response time setting	Sets the response time. Select a response time from 2.5 ms, 5 ms, 10 ms, 25 ms, 50 ms, 100 ms, 250 ms, 500 ms, 1000 ms, or 5000 ms.
Main display color switching	You can switch the color of the main display. Set red/green or green/red depending on whether output is ON/OFF. Also, you can set whether the normal color is red or green.
Unit switching (high-pressure type only)	You can switch the units for the pressure.

Remarks: See the instruction manual provided with the product for details about setting the modes, functions and values.

# Input/output circuit and connections

## Input/output circuit diagram

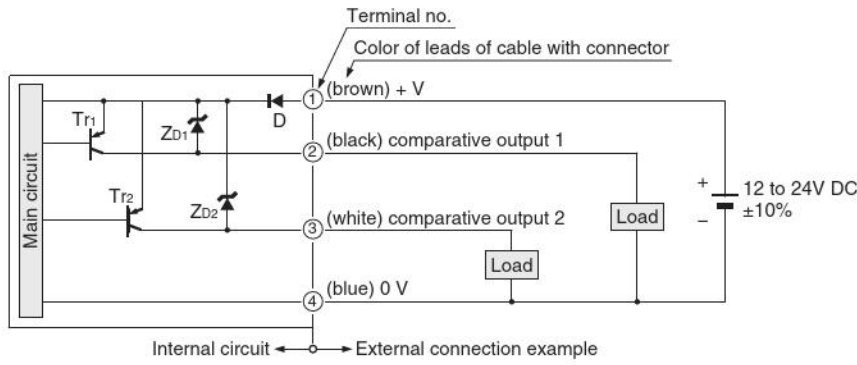

Code...D : Reverse current protection diode for power supply  
ZD1, ZD2 : Zener diodes for surge voltage absorption  
Tr1, Tr2 : PNP output transistor

## Terminal layout

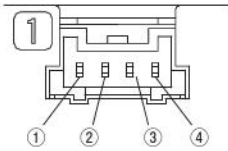

Terminal no.	Name
①	+V
②	Comparative output 1
③	Comparative output 2
④	0V

## Order codes

**GS6 20 - 3W**

Digital pressure switch

NPT thread specifications

Operating pressure range

20 : High-pressure type -14.5 to +145 psi

## Dimensions in.

### GS620-3W

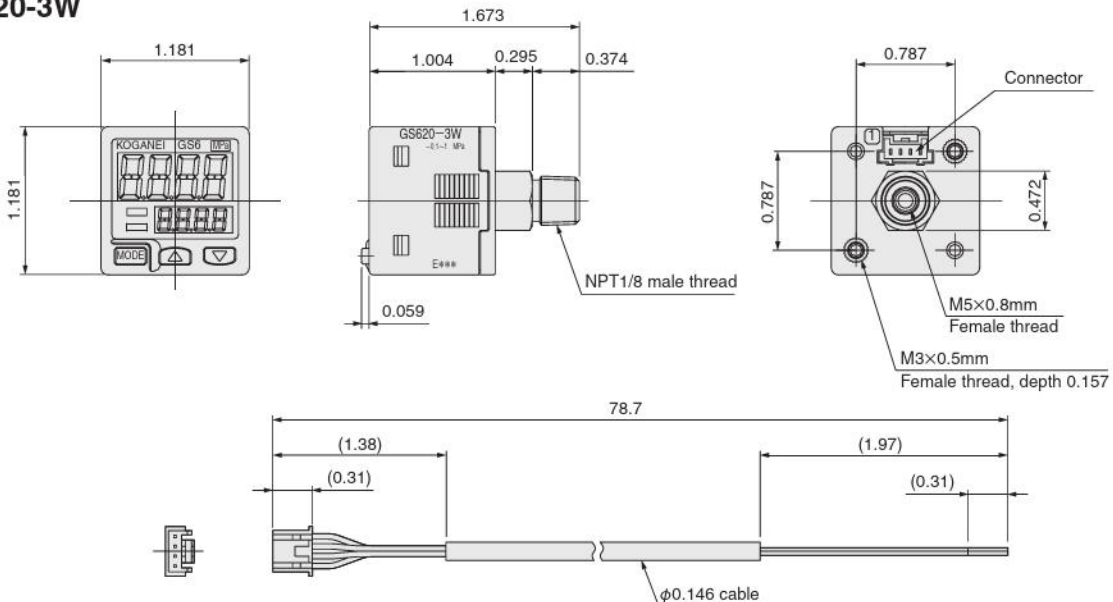

# Pressure gauge with built-in switches

## GS1-50-F11

- The set pressure and operating pressure are indicated on the same pressure gauge. Panel mounting offers convenient centralized control and management built into the control panel.
- An indicator is standard equipment, to check the switch operation state. Wiring connection methods offered include a standard grommet (lead wire) type, and a DIN connector type as an option.

### Symbol

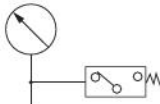

### Order codes

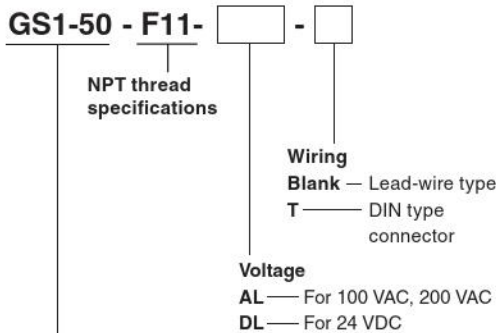

Pressure gauge with built-in switch  
(outer diameter 1.969 in.)

Remarks: A model with built-in contact protection circuit (external surge absorption element) for AC is available. Contact your nearest Koganei sales office for details.

### Specifications

Item	Model	GS1-50-F11-[ ]-[ ]	
Medium		Air	
Maximum operating pressure	psi	120	
Pressure gauge specifications	Operating temperature range (atmosphere and medium)	°F 41 to 140	
	Pressure indicator range	psi 0 to 145	
	Indicator accuracy	F.S. ±3%	
Switch specifications	Pressure adjusting range	psi 14.5 to 120	
	Regulating pressure indication error <sup>Note 1 and Note 3</sup>	psi ±7	
	Repeatability <sup>Note 3</sup>	psi ±7 (41 to 113°F)	
	Response differential	psi 10 or less	
	Contact type	Micro switch a-contact (NO)	
	Wiring	Standard	Lead wire length: Approx. 19.7 in. (UL1007 AWG22)
	Options	DIN connector	
Indicator	Standard equipment is LED for DC and neon lamp for AC		
Shock resistance	G	1	
Mounting direction	Any		
Mass	oz	6.00 (with DIN connector 6.70)	
Materials	Body	Aluminum die-casting	
	Case	SPCC	
	Connection port thread	Brass	
	Bourdon tube	Brass	

- Notes 1: Shows when the pressure is rising.  
 2: Use a set pressure that has a differential of at least 14.5 psi with the supply pressure.  
 3: Regulating pressure indicator errors and repeatability errors could be accumulated. (maximum ±14.5 psi) Be careful during operations.

### Micro switch rating

Rated voltage		30 VDC	125 VAC	250 VAC
Operating current range				
Inductive load	Continuous	0.05 to 0.1	0.01 to 0.1	0.01 to 0.05
	Inrush	0.5 MAX.	0.5 MAX.	0.2 MAX.
Non-inductive load		0.01 to 0.5	0.01 to 0.3	0.01 to 0.2

### Dimensions of pressure gauge with built-in switch in.

#### GS1-50-F11-[ ]-[ ]

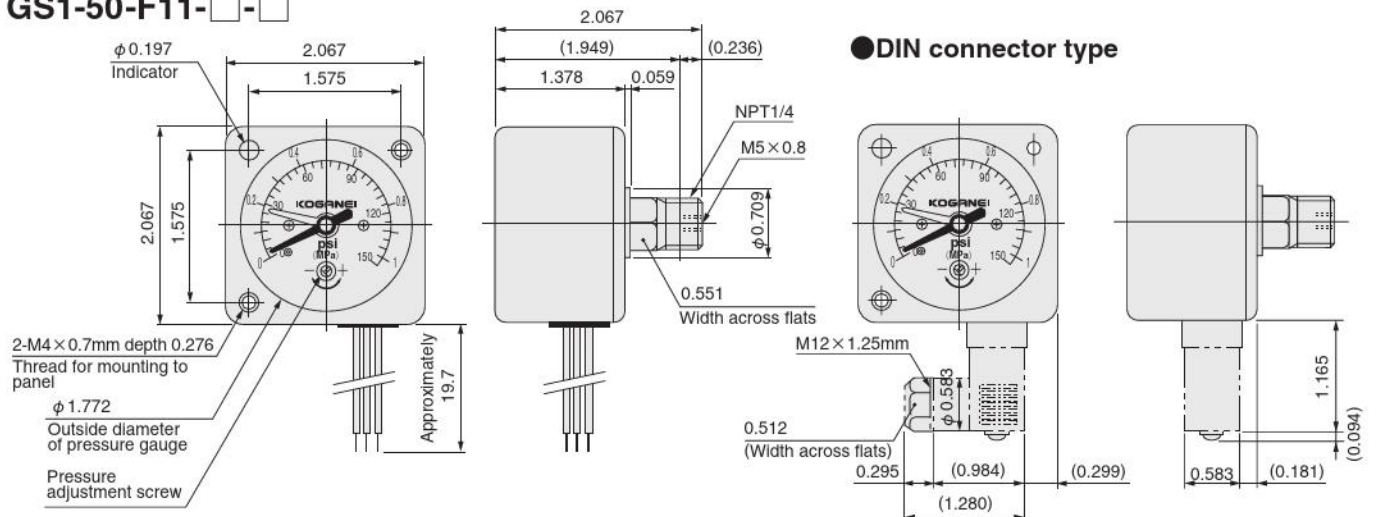

# Handling instructions and Precautions



## Pressure gauge with built-in switches

### Mounting and piping

1. While any mounting direction is acceptable, install a throttle mechanism in cases where pressure pulsation is particularly severe, such as when mounted between a valve and an actuator. For mounting in locations subject to strong vibrations, consult us.
2. During mounting and piping operations, do not grab the pressure gauge body to tighten. For tightening, always use a wrench on the piping connection port hexagonal section. Use a tightening torque of 2.21 to 3.69 ft·lbf when the pressure gauges are mounted on the pressure port plate with NPT1/4.

### Pressure regulation

Rotate the pressure adjustment screw, align the pressure regulation needle (red) to the set pressure, and set. Rotating the pressure adjustment screw to the left (counterclockwise) sets to a higher pressure, and rotating it to the right (clockwise) sets to a lower pressure. When the air pressure rises to the set pressure, the switch is activated, and when it falls to less than the setting pressure 10 psi (response differential), the switch is returned to the original state.

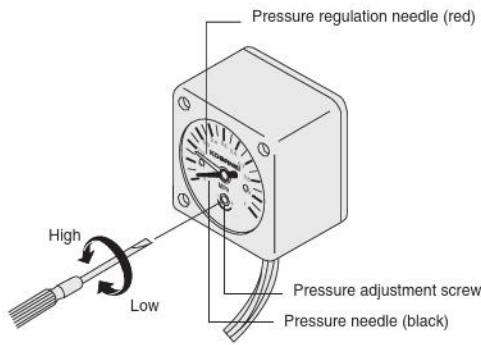

- Note**
1. To regulate the pressure, do not remove the cap on the lens surface, but insert a small screwdriver into a slit in the cap instead, and directly rotate the pressure adjustment screw.
  2. The pressure needle has an indication error of  $\pm 7$  psi. For fine-tuning adjustment, apply compressed air at the set pressure to check the switch triggering action.

### Switch setting method and operations

Setting example: Want the switch to activate when the pressure is at 43.5 psi or less.

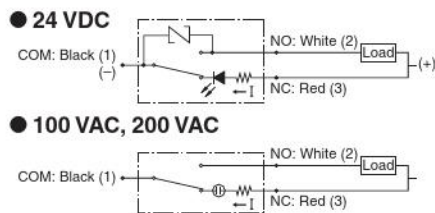
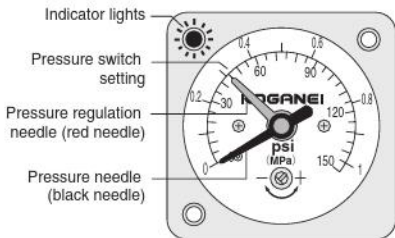

Set the pressure regulation needle (red needle) to 43.5 psi. When the pressure is in the range of 0 to 43.5 psi, the built-in switch remains at NC, as shown in the circuit diagram above, and the indicator lamp lights up.

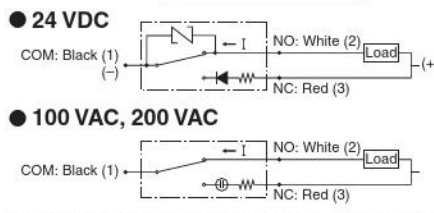
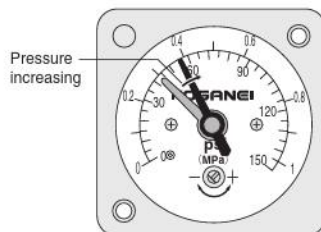

When the pressure supply increases, close to the pressure regulation needle (red needle), the built-in switch flips to NO, as shown in the circuit diagram above, the load current flows, and the indicator lamp goes out. The position at this time is A. At this time switching position A has a maximum 14.5 psi differential in relation to the pressure needle (black needle) because of a pressure needle tolerance of  $\pm 7$  psi and repeatability accuracy of  $\pm 7$  psi have accumulated.

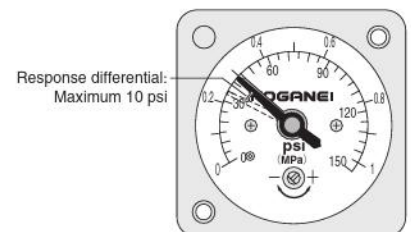

When the pressure falls, and the pressure needle (black needle) is higher than the pressure regulation needle (red needle), the internal switch changes to NC with a maximum response differential of 10 psi. When this happens, check the switching position and adjust the pressure regulation needle (red needle). Note that NC cannot be used as a load contact. Use the switching of NO to OFF by controlling a relay or other B-contact device.

### General precautions

1. Use this product to check the supply pressure. For use in precision control circuits, consult us.
2. Switch performance may be degraded in installation locations where the temperature is higher than 113°F or where the humidity is constantly 50% or less. For use in these kinds of places, consult us.
3. If there is silicon gas in the ambient atmosphere, it may cause a contact failure because the contact operation uses micro switches. If there is silicon oil or silicon products in the vicinity of the product, eliminate the source of the silicon gas or use a contact protection circuit (for AC).

### Wiring instructions

Pay attention to the NC and NO contacts and the colors of lead wires (when in wires with connectors, the terminal numbers) for wiring. In the diagram below, the numbers in parentheses ( ) represent the terminal numbers, while the  $\uparrow$  shows the direction of rising pressure. The indicator lamp switches off when the value is at the set pressure or higher, and lights up as a warning when the value falls below the set pressure.

#### ● 24 VDC

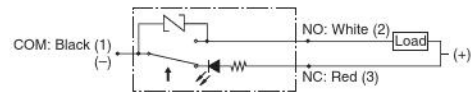

#### ● 100 VAC, 200 VAC



#### ● Wiring instructions with DIN connector

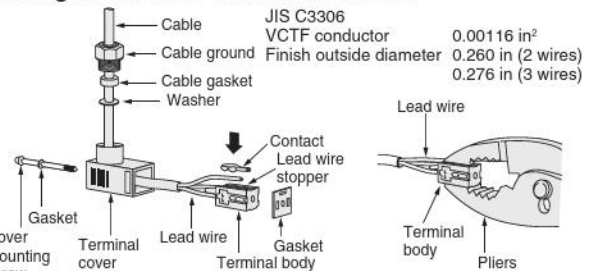

When peeling off the cable sheath (for cabtyre sheath only), pay attention to the lead wire bending direction. Setting the outer lead wires inside the terminal cover to be about 0.31 in longer than the inner wires can make it easier to mount the terminal body onto the terminal cover. For lead wires, without peeling off their insulations, insert them into the terminal body until they bump up against the lead wire stopper, lower the contact from above to the lead wire, and use pliers to push them into firm contact, so that the contacts are touching the core wire.

**Note** For the connector type, the connector wiring position at time of delivery is in the connecting thread side (back side).

M E M O

A series of horizontal dashed lines for writing.

M E M O

A series of horizontal dashed lines for writing.



# Limited Warranty

KOGANEI CORP. warrants its products to be free from defects in material and workmanship subject to the following provisions.

**Warranty Period** The warranty period is 180 days from the date of delivery.

**Koganei Responsibility** If a defect in material or workmanship is found during the warranty period, KOGANEI CORP. will replace any part proved defective under normal use free of charge and will provide the service necessary to replace such a part.

**Limitations**

- This warranty is in lieu of all other warranties, expressed or implied, and is limited to the original cost of the product and shall not include any transportation fee, the cost of installation or any liability for direct, indirect or consequential damage or delay resulting from the defects.

- KOGANEI CORP. shall in no way be liable or responsible for injuries or damage to persons or property arising out of the use or operation of the manufacturer's product.

- This warranty shall be void if the engineered safety devices are removed, made inoperative or not periodically checked for proper functioning.

- Any operation beyond the rated capacity, any improper use or application, or any improper installation of the product, or any substitution upon it with parts not furnished or approved by KOGANEI CORP., shall void this warranty.

- This warranty covers only such items supplied by KOGANEI CORP. The products of other manufacturers are covered only by such warranties made by those original manufacturers, even though such items may have been included as the components.

The specifications are subject to change without notice.

URL <http://www.koganei.co.jp>

E-mail: [overseas@koganei.co.jp](mailto:overseas@koganei.co.jp)



## KOGANEI CORPORATION

### OVERSEAS DEPARTMENT

3-11-28, Midori-cho, Koganei City, Tokyo 184-8533, Japan  
Tel: 81-42-383-7271 Fax: 81-42-383-7276

### KOGANEI INTERNATIONAL AMERICA, INC.

39300 Civic Center Dr., Suite 280, Fremont, CA 94538, U.S.A.  
Tel: 1-510-744-1626 Fax: 1-510-744-1676

### SHANGHAI KOGANEI INTERNATIONAL TRADING CORPORATION

Room 2606-2607, Tongda Venture Building No.1, Lane 600, Tianshan Road,  
Shanghai, 200051, China  
Tel: 86-21-6145-7313 Fax: 86-21-6145-7323

### TAIWAN KOGANEI TRADING CO., LTD.

Rm. 2, 13F, No88, Sec. 2, Zhongxiao E. Rd., Zhongzheng Dist., Taipei City 100,  
Taiwan (ROC)  
Tel: 886-2-2393-2717 Fax: 886-2-2393-2719

### KOGANEI KOREA CO., LTD.

6F-601, Tower Bldg., 1005, Yeongdeu-dong, Giheung-gu, Yongin-si, Gyeonggi-do,  
446-908, Korea  
Tel: 82-31-246-0414 Fax: 82-31-246-0415

### KOGANEI (THAILAND) CO., LTD.

3300/90, Tower B, Elephant Tower, 16th Fl., Phaholyothin Road, Chomphon,  
Chatuchak, Bangkok 10900, Thailand  
Tel: 66-2-937-4250 Fax: 66-2-937-4254

### KOGANEI ASIA PTE. LTD.

69 Ubi Road 1, #05-18 Oxley Bizhub, Singapore 408731  
Tel: 65-6293-4512 Fax: 65-6293-4513