

Combinations

● 650 series combination



● 750 series combination



● 900 series combination



Filters and Mist Filters



● Options

- Non-ion specification
- Bowl specification:
Nylon bowls
- Drain cock specification:
Drain cock with fitting
Auto drain type drain cock

Modules

D module for bracket-
combined use



R module



Regulators



RN650
RN651
RN652



RN900
RN902

● Options

Pressure gauge with built-in switch



Pressure gauge



Pressure gauge
for low pressure



Digital pressure
gauge with built-in
sensor



Embedded pressure
gauge

Modules

D module for bracket-
combined use



R module



Lubricators



LN650
LN651



LN900
LN901
LN902

● Options

- Non-ion specification
- Lubricator specification:
 - Micro lubricator
 - Machine lubricator
- Bowl specification:
 - Nylon bowls
- Drain cock specification:
 - Drain cock with fitting
 - Screw type drain cock









List of Equipment Combination

Body size		650 series						900 series										
Model		FN650	RN650	RN651	RN652	LN650	LN651	FN900	FN901	RN900	RN902	LN900	LN901	LN902	MF800	MF1000	MMF600	MMF800
650 series	FN650	8-65F	8-90ND				8-65F	8-90ND				8-65F	8-90ND					
	RN650	8-65ND	8-90DT				8-65ND	8-90DT				8-65T	8-90DT					
	RN651	8-65T	8-90DS				8-65T	8-90DS				8-65S	8-90DS					
	RN652	8-65DT				8-65DT		8-90R ^{Note}										
	LN650	8-65S				8-65S		8-90M ^{Note}										
	LN651	8-65DS				8-65DS												
900 series	FN900	8-65F	8-90ND				8-65F	8-90ND				8-65F	8-90ND					
	FN901	8-65ND	8-90DT				8-65ND	8-90DT				8-65T	8-90DT					
	RN900	8-65T	8-90DS				8-65T	8-90DS				8-65S	8-90DS					
	RN902	8-65DT	8-90R ^{Note}				8-65DT	8-90R ^{Note}				8-90R ^{Note}						
	LN900	8-65S	8-90M ^{Note}				8-65S	8-90M ^{Note}				8-90M ^{Note}						
	LN901	8-65DS				8-65DS												
	LN902																	
	MF800	8-65F	8-90ND				8-90ND	8-90R ^{Note}				8-65F	8-90ND					
	MF1000	8-65T	8-90R ^{Note}				8-90DT	8-90M ^{Note}				8-65T	8-90DT					
	MMF600	8-65S	8-90M ^{Note}				8-90DS					8-65S	8-90DS					
MMF800																		

Note: Only for RN900 and RN902. For connection with RN900 or RN902, modules other than 8-90R and 8-90M cannot be used. These also cannot be used to connect modules other than RN900 and RN902 to each other.

List of Module Adapter Types

For 650, 900 series

Module and adapter	F module	D module	T module	
	F	ND	T	DT
Body size	 (For modules only)	 (Brackets for combined use)	 (Branch piping)	 (Brackets for combined use with branch piping)
65 (650 series)	8-65F	8-65ND	8-65T	8-65DT
90 (900 series)		8-90ND		8-90DT
Modules and adapters	R module	M module	S adapter	
	R	M	S	DS
Body size	 (For regulator only)	 (For supporting regulator piping only)	 (Port connection)	 (Brackets for combined use with piping connection)
65 (650 series)	—	—	8-65S	8-65DS
90 (900 series)	8-90R	8-90M		8-90DS

F.R.L. COMBINATIONS

CN650, CN750, CN750A, CN900,
CN900A, CY650, CY900, CY900A,
CZ650, CZ900



Symbols

● CN

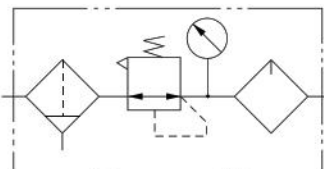

● CY

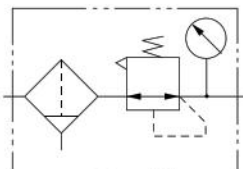

● CZ

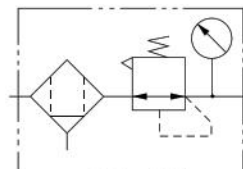

Specifications

Item	Model	CN650	CN750	CN750A	CN900	CN900A	CY650	CY900	CY900A	CZ650	CZ900
Media		Air or non-corrosive gas									
Port size	Rc	3/4, 1									
Filtration rating	μ m	5		40	5	40	5		40		0.3
Pressure setting range	MPa [psi.]	0.05~0.83 [7~120]									
Max. operating pressure	MPa [psi.]	0.97 [141]									
Proof pressure	MPa [psi.]	1.47 [213]									
Operating temperature range	$^{\circ}$ C [$^{\circ}$ F]	5~60 [41~140]									
Air filter drain capacity	cc [in. ³]	90 [5.5]		130 [7.9]			90 [5.5]		130 [7.9]		160 (MF800) [9.8]
Oil capacity for lubricator	cc [in. ³]	160 [9.8]									
Recommended lubrication		Turbine oil Class 1 [ISO VG32]									
Oil mist separating efficiency	%	99.9									
Max. processed flow rate	ℓ /min [ft ³ /min] (ANR)	2000 [70.6]			6000 [212]		2000 [70.6]	6000 [212]		2000 [70.6]	4000 [141]
Mass	kg [lb]	Standard	2.29 [5.05]	3.48 [7.67]	3.44 [7.59]	1.43 [3.15]	2.35 [5.18]	2.50 [5.51]	2.76 [6.09]		
	Auto drain type	2.32 [5.12]	3.51 [7.74]	3.47 [7.65]	1.46 [3.22]	2.38 [5.25]	2.53 [5.58]	2.80 [6.17]			
Materials	Body	Aluminum die-casting									
	Bowl	Polycarbonate								Aluminum die-casting	
Models of included components	Air filter	FN650	FN900	FN901	FN900	FN901	FN650	FN900	FN901	MF800	MF800
	Regulator	RN650	RN650	RN650	RN900	RN900	RN650	RN900	RN900	RN650	RN900
	Lubricator	LN650	LN900	LN900	LN900	LN900	—	—	—	—	—
Standard attachments	Bracket	8-65ND			8-90R		8-65ND	8-90R		8-90ND	8-90R
	Air filter	Screw type drain cock, bowl guard								Screw type drain cock	
	Regulator	—									
	Lubricator	Bowl guard								—	

Order Codes

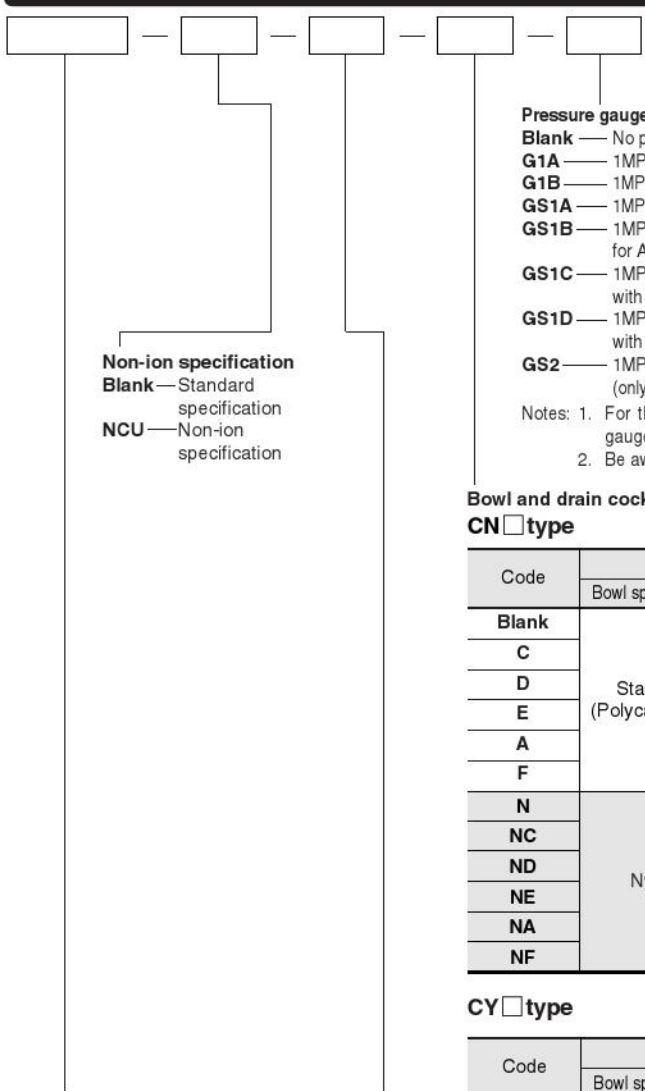

Non-ion specification
Blank — Standard specification
NCU — Non-ion specification

Pressure gauge specification

- Blank** — No pressure gauge
- G1A** — 1MPa [145psi.] specification, ϕ 40 pressure gauge^{Note2}
- G1B** — 1MPa [145psi.] specification, \square 30 Embedded pressure gauge (only for 900 series)^{Note1}
- GS1A** — 1MPa [145psi.] specification, \square 50 Pressure gauge with built-in switch for DC24V^{Note1}
- GS1B** — 1MPa [145psi.] specification, \square 50 Pressure gauge with built-in switch for AC100V and AC200V^{Note1}
- GS1C** — 1MPa [145psi.] specification, \square 50 Pressure gauge with built-in switch with DIN connector for DC24V^{Note1}
- GS1D** — 1MPa [145psi.] specification, \square 50 Pressure gauge with built-in switch with DIN connector for AC100V and AC200V^{Note1}
- GS2** — 1MPa [145psi.] specification, \square 30 Digital pressure gauge with built-in sensor (only for 900 series)^{Note2}

Notes: 1. For the specifications, order codes, and dimensions of the pressure gauge and the pressure gauge with built-in switch, see p.172 and 183.
 2. Be aware that **-G1B** and **-GS2** cannot be selected with a non-ion specification.

Bowl and drain cock specification

CN \square type

Code	Specification		
	Bowl specification	Air filter specification	Lubricator specification
Blank	Standard (Polycarbonate)	Screw type drain cock	Without drain cock
C		Without drain cock	Without drain cock
D		Screw type drain cock	Screw type drain cock
E		Drain cock with fitting	Without drain cock
A		Auto drain type drain cock	Without drain cock
F		Drain cock with fitting	Drain cock with fitting
N		Nylon	Screw type drain cock
NC	Without drain cock		Without drain cock
ND	Screw type drain cock		Screw type drain cock
NE	Drain cock with fitting		Without drain cock
NA	Auto drain type drain cock		Without drain cock
NF	Drain cock with fitting		Drain cock with fitting

CY \square type

Code	Specification	
	Bowl specification	Air filter specification
Blank	Standard (Polycarbonate)	Screw type drain cock
C		Without drain cock
E		Drain cock with fitting
A		Auto drain type drain cock
N	Nylon	Screw type drain cock
NC		Without drain cock
NE		Drain cock with fitting
NA		Auto drain type drain cock

CZ \square type

Code	Specification	
	Bowl specification	Mist filter specification
Blank	Aluminum die-casting	Screw type drain cock
F1		Drain cock with fitting
A		Auto drain type drain cock

F.R.L. Large Flow combination	Port size	
Body model	Rc3/4	Rc1
CN650	06	08
CN750	06	08
CN750A	06	08
CN900	06	08
CN900A	06	08
CY650	06	08
CY900	06	08
CY900A	06	08
CZ650	06	08
CZ900	06	08

Body model	Component included				
	Air filter	Regulator	Lubricator	Mist filter	Mounting module and adapter
CN650	FN650	RN650	LN650	—	8-65ND
CN750	FN900	RN650	LN900	—	8-65ND
CN750A ^{Note}	FN901	RN650	LN900	—	8-65ND
CN900	FN900	RN900	LN900	—	8-90R
CN900A ^{Note}	FN901	RN900	LN900	—	8-90R
CY650	FN650	RN650	—	—	8-65ND
CY900	FN900	RN900	—	—	8-90R
CY900A ^{Note}	FN901	RN900	—	—	8-90R
CZ650	—	RN650	—	MF800	8-90ND
CZ900	—	RN900	—	MF800	8-90R

Note: **CN750A**, **CN900A** and **CY900A** filter elements are 40 μ m. All others are 5 μ m.

Inner Construction

● CN

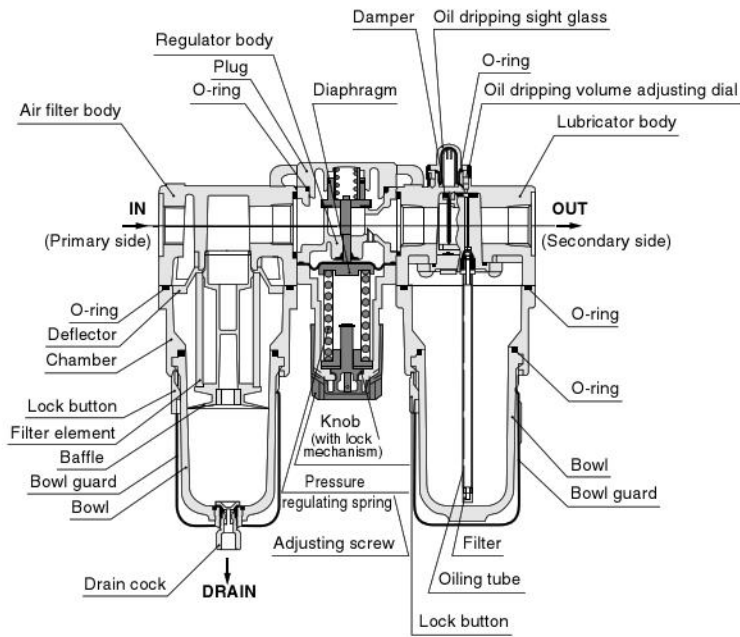

● CY

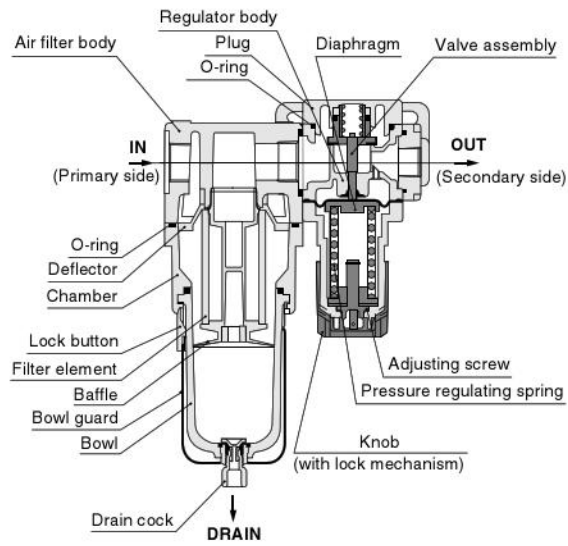

● CZ

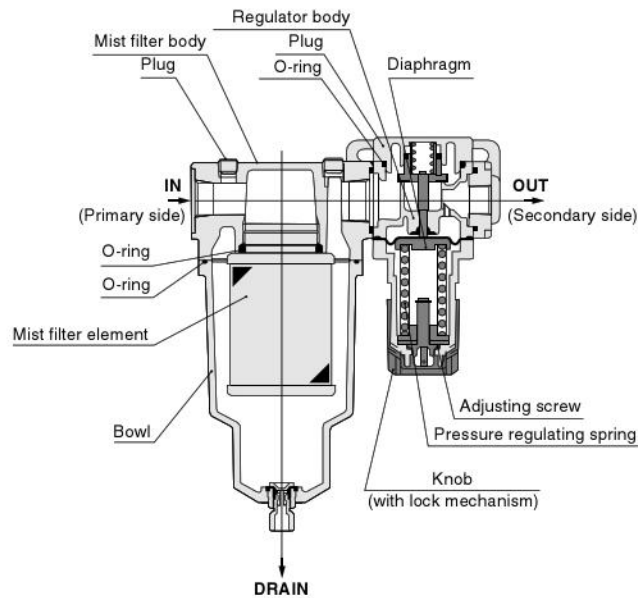

Flow Rate Characteristics

CN650

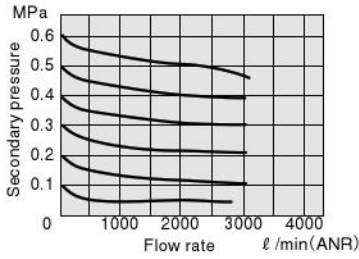

CN750

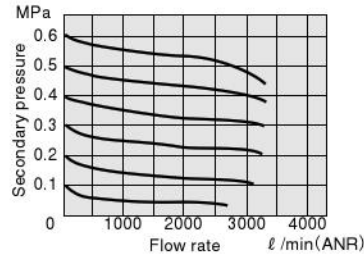

CN900

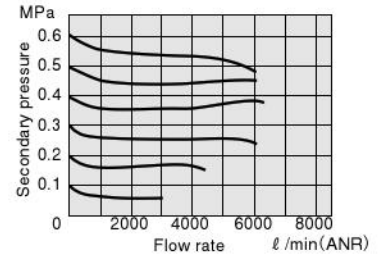

CY650

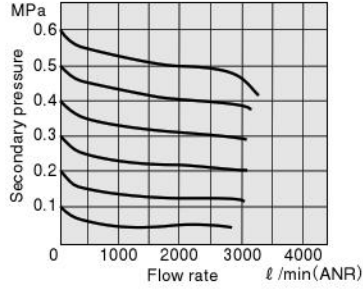

CY900

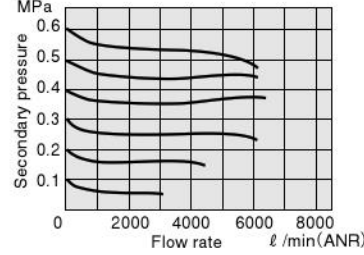

CZ650

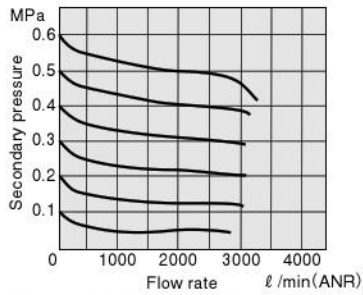

CZ900

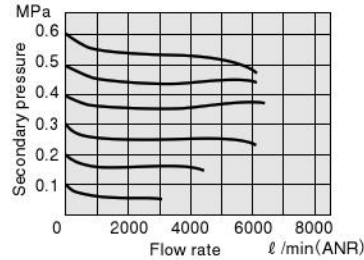

1MPa = 145psi. 1 l/min = 0.0353ft³/min.

Remark: Graphs show flow rate characteristics when the primary pressure is at 0.7MPa [102psi].

Pressure Characteristics

CN650

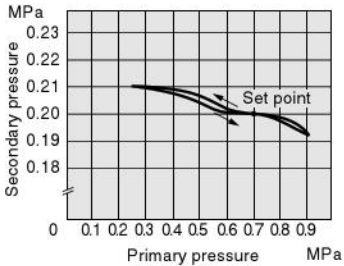

CN750

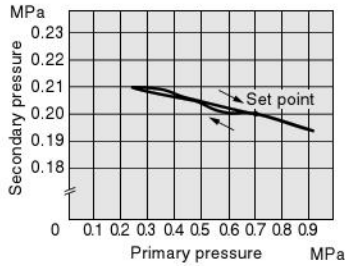

CN900

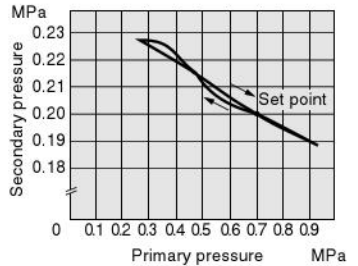

CY650

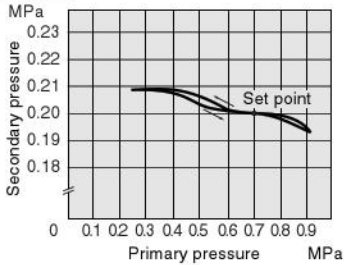

CY900

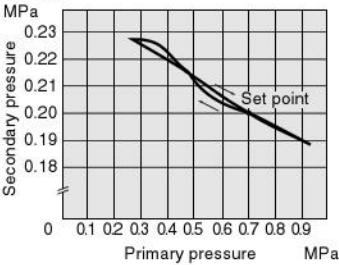

CZ650

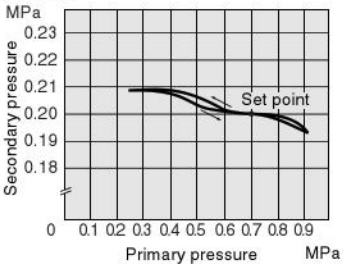

CZ900

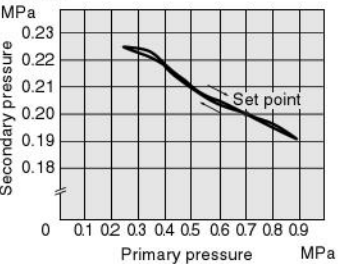

1MPa = 145psi.

Dimensions of F.R.L. Combinations (mm)

CN650

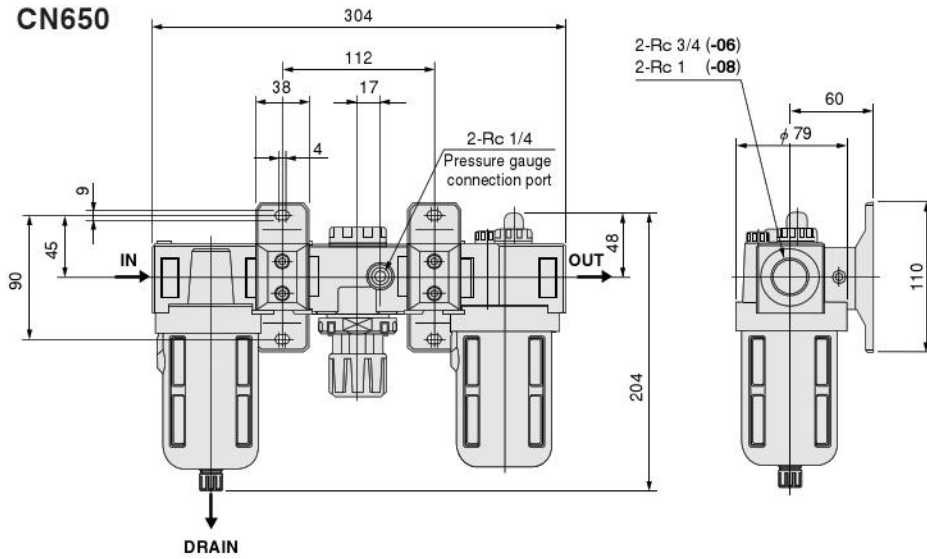

Optional pressure gauges

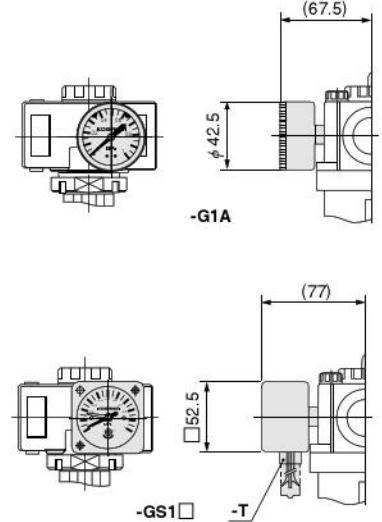

CN750

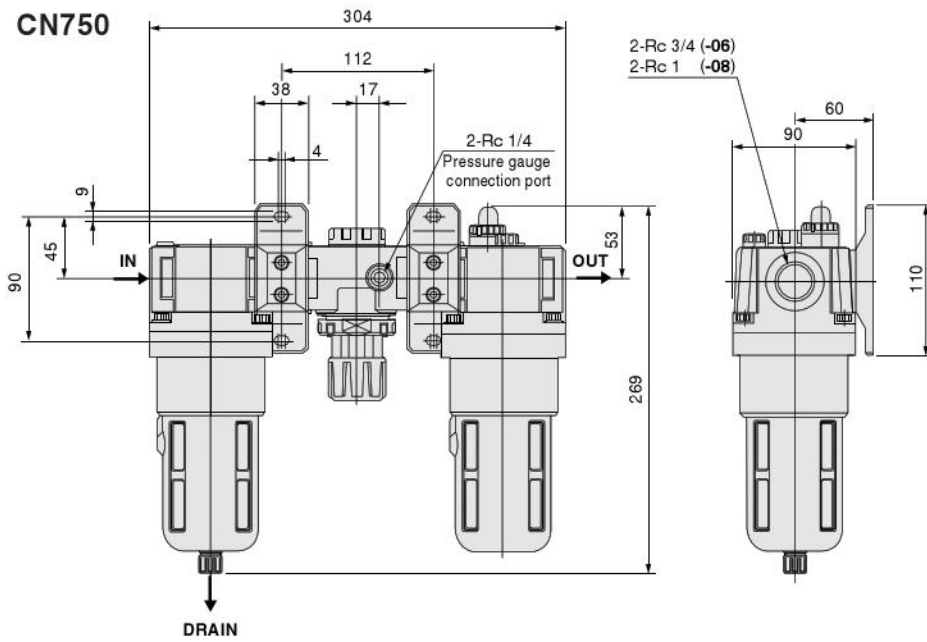

Optional pressure gauges

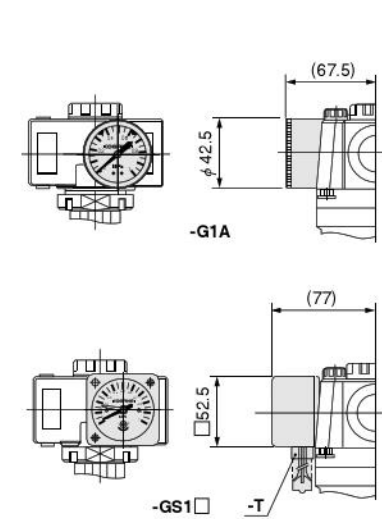

CN900

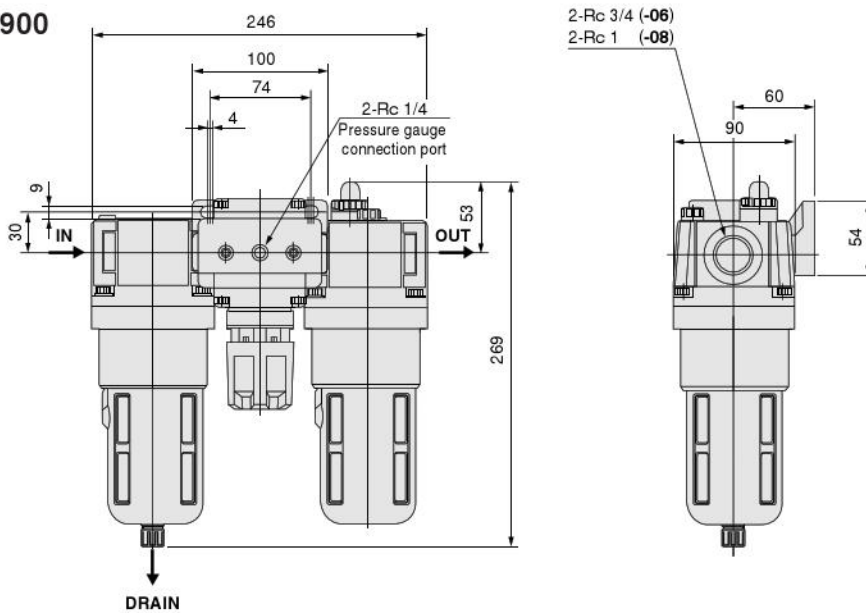

Optional pressure gauges

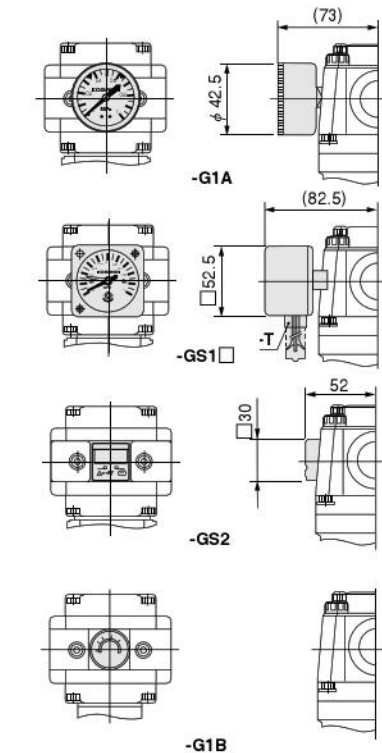

CY650

● Optional pressure gauges

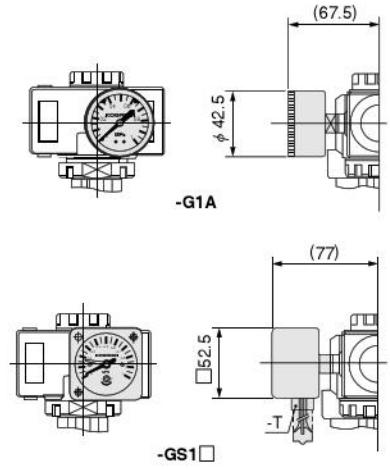
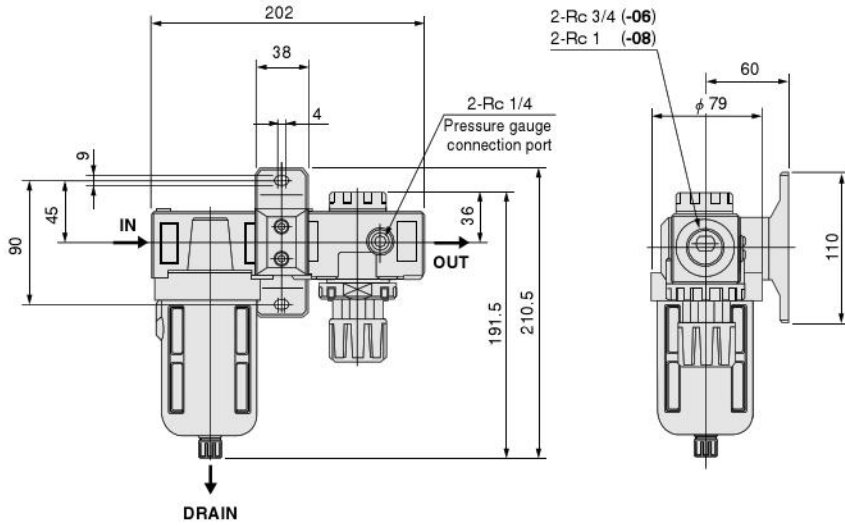

CY900

● Optional pressure gauges

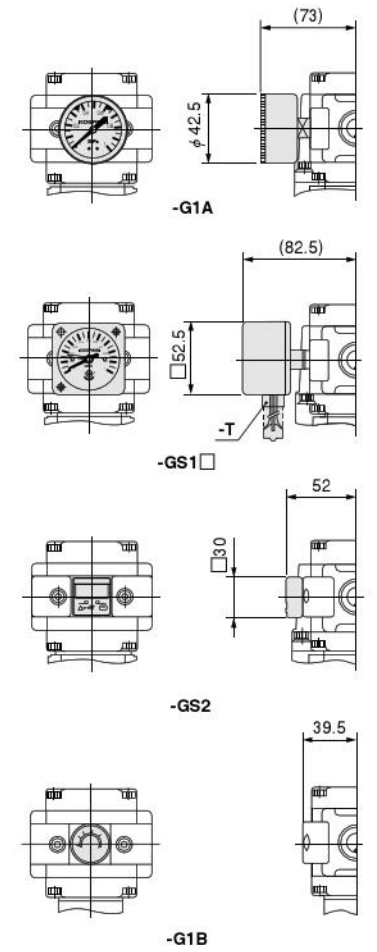
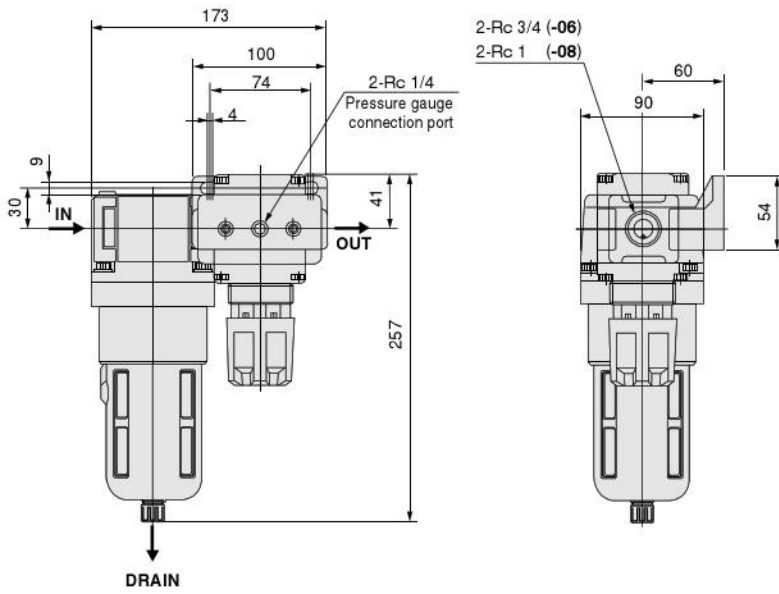

Dimensions of F.R.L. Combinations (mm)

CZ650

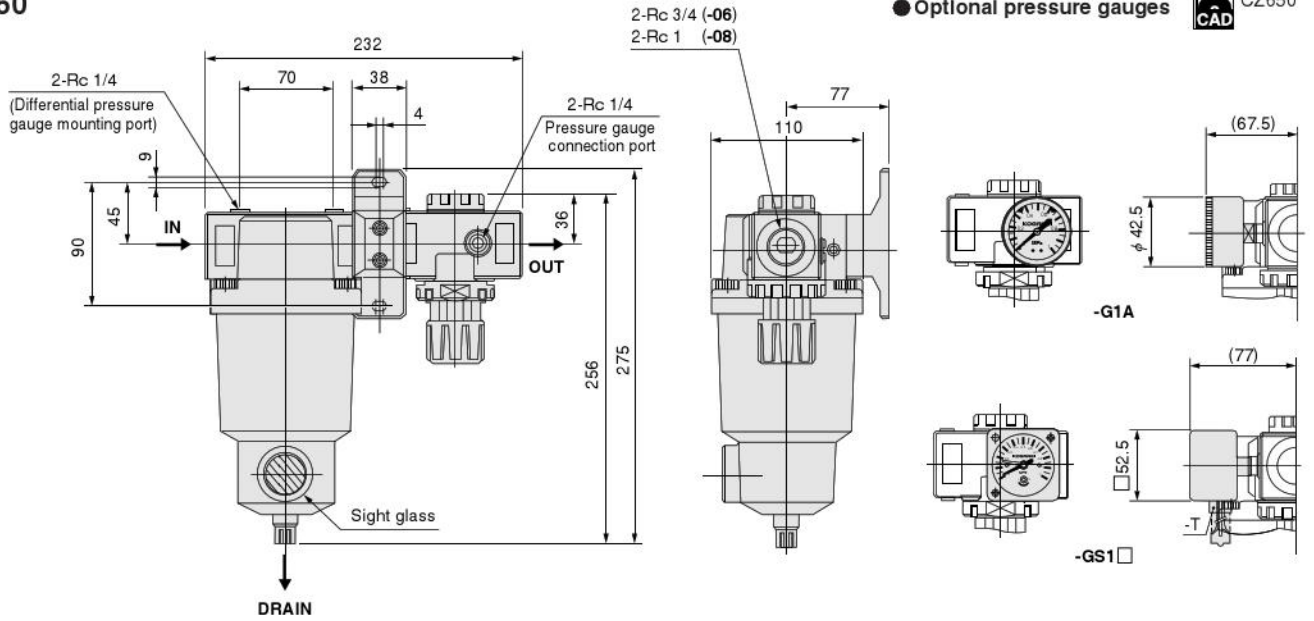

CZ900

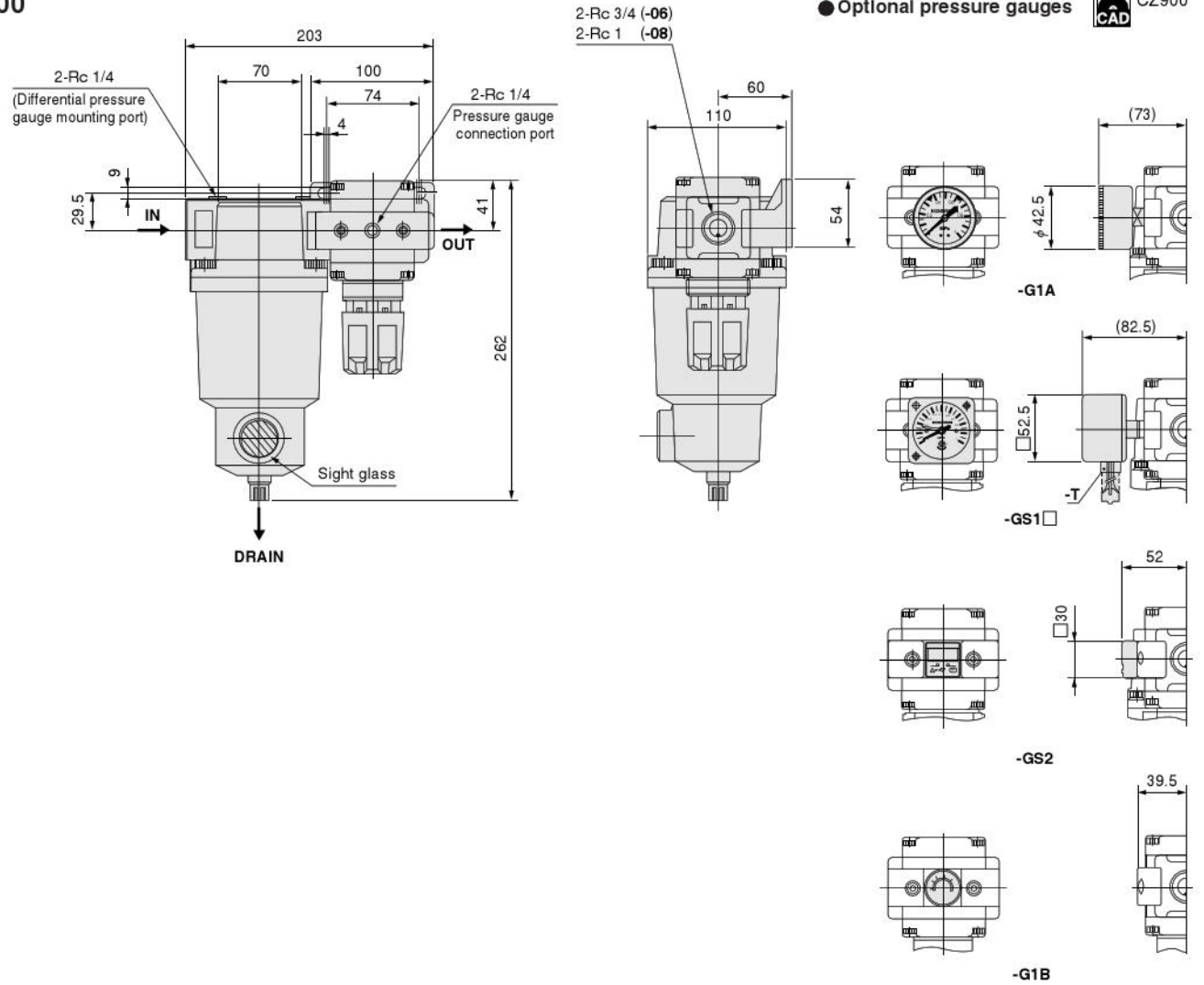

Inner Construction

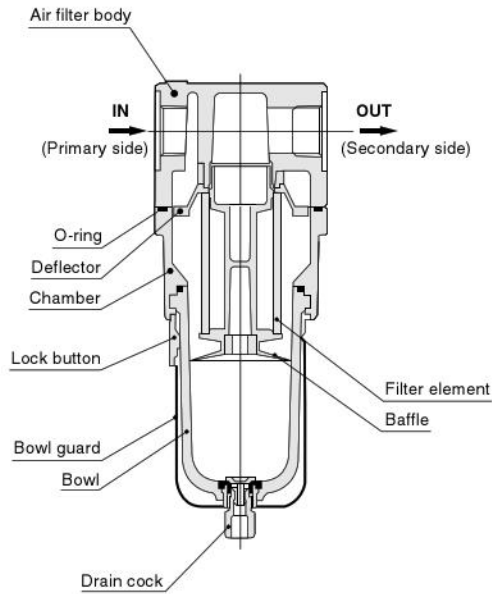

● Screw type drain cock

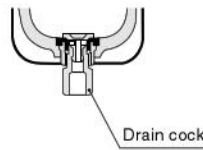

● Without drain cock



● Drain cock with fitting

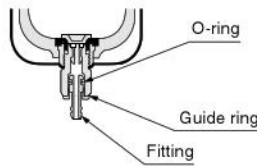

● Auto drain type drain cock

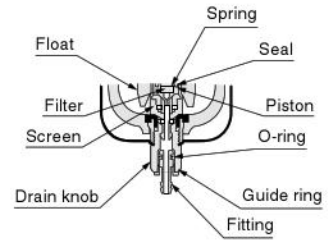

Inner Construction of Auto Drain

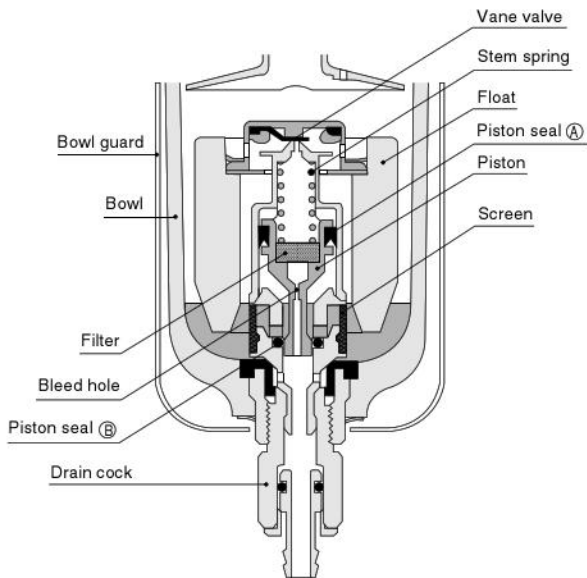

Condition of collected liquid

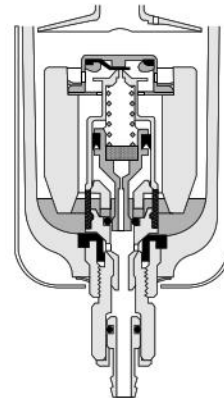

Condition of draining liquid

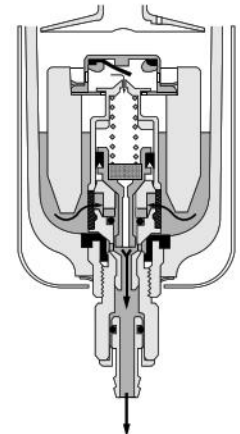

Operation principles

When liquid collects inside the bowl, the float rises and opens up the vane valve. Air brought to the top of the piston forces the piston downward, opening up the bottom of the piston and expelling liquid that has passed through the screen. As the liquid is drained out, the float falls, closing the vane valve. Air at the top of the piston is released through a bleed hole, and air pushes up on the piston from the bottom, returning the unit to the normal state.

If pressure inside the bowl is lost, the stem spring pushes down on the piston to drain out all of the liquid. After the liquid has been drained out, the air inside the bowl is also exhausted.

Remark: Air is exhausted from the drain port until the supply pressure rises to 0.15MPa [22psi.]. In this situation, even rotating the drain knob will not prevent the air from bleeding out.

Dimensions of Air Filters (mm)

FN650

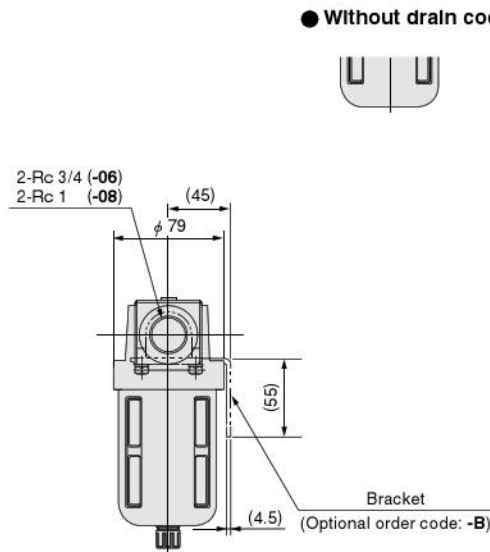
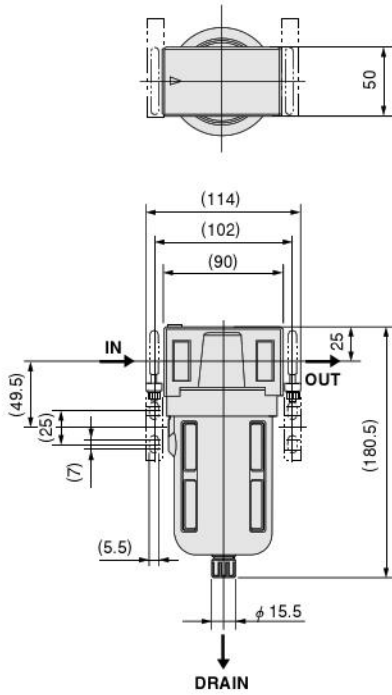

● Without drain cock



● Screw type drain cock

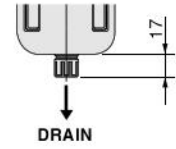

● Drain cock with fitting
● Auto drain type drain cock

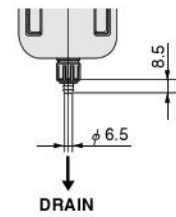

FN900 FN901

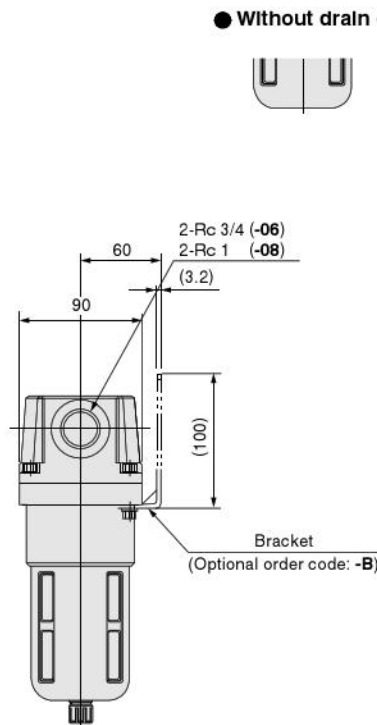
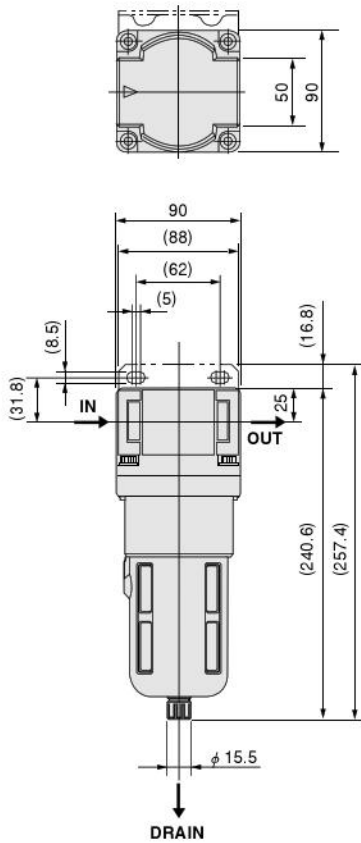

● Without drain cock



● Screw type drain cock

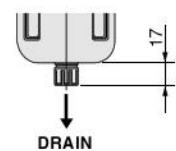

● Drain cock with fitting
● Auto drain type drain cock

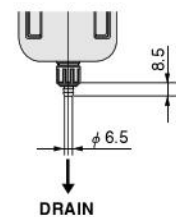

MIST FILTERS

MF800, MF1000

Symbol

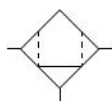

Specifications

Item	Model	MF800	MF1000
Media		Air	
Port size	Rc	1/2, 3/4, 1	
Filtering particle diameter	μm	0.3	
Filtering efficiency	%	99.9	
Volume of processed air ¹⁾	ℓ/min [ft^3/min] (ANR)	4000 [141]	6000 [212]
Max. operating pressure	MPa [psi.]	0.97 [141] (Auto drain type: 0.15~0.97 [22~141])	
Proof pressure	MPa [psi.]	1.47 [213]	
Operating temperature range (atmosphere and media)	$^{\circ}\text{C}$ [$^{\circ}\text{F}$]	5~60 [41~140]	
Drain capacity	cc [in. ³]	160 [9.8]	
Mass	kg [lb]		
		Standard	2.10 [4.63]
		Auto drain type	2.13 [4.70]
Materials	Body, bowl	Aluminum die-casting	
	Sight glass	Reinforced glass	
	Element type	E-80M	E-100M
Standard attachments		Screw type drain cock	

Note: This is the recommended maximum flow rate when the air pressure is 0.69MPa [100psi.].

Order Codes

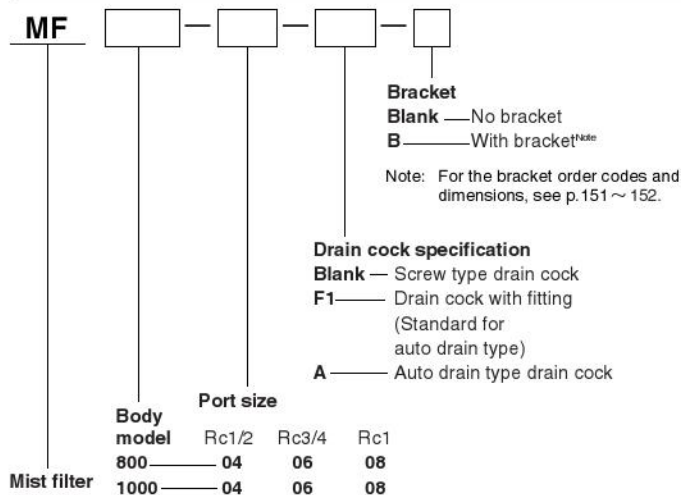

Inner Construction

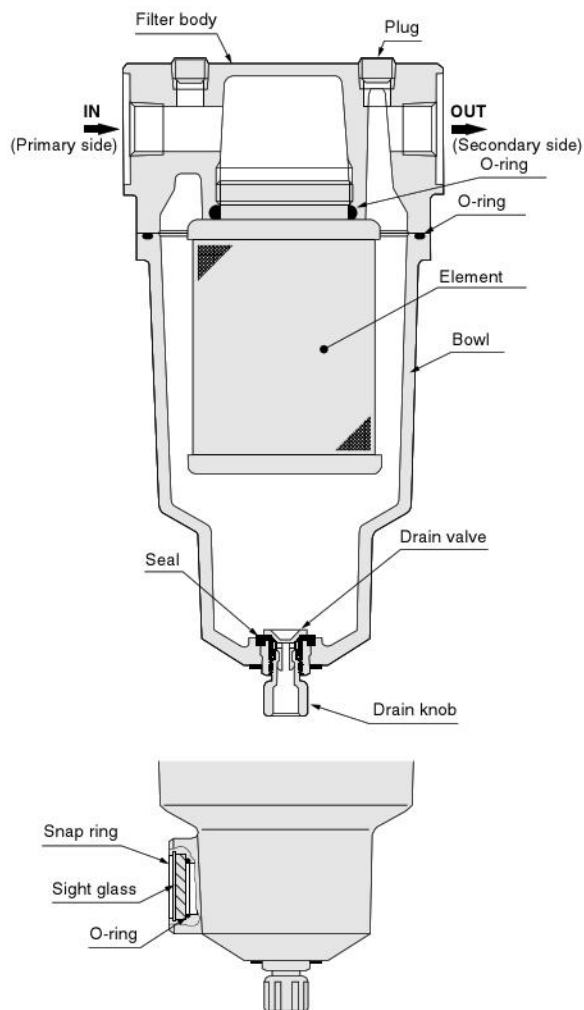

Flow Rate Characteristics

MF800

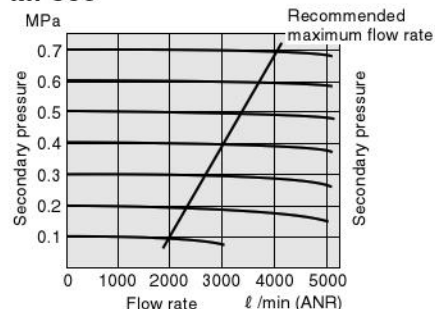

MF1000

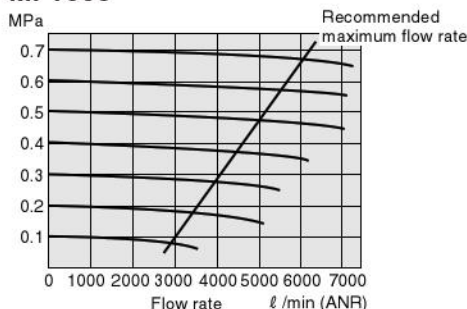

1MPa = 145psi. 1 ℓ/min = 0.0353ft³/min.

Dimensions of Mist Filters (mm)

MF800

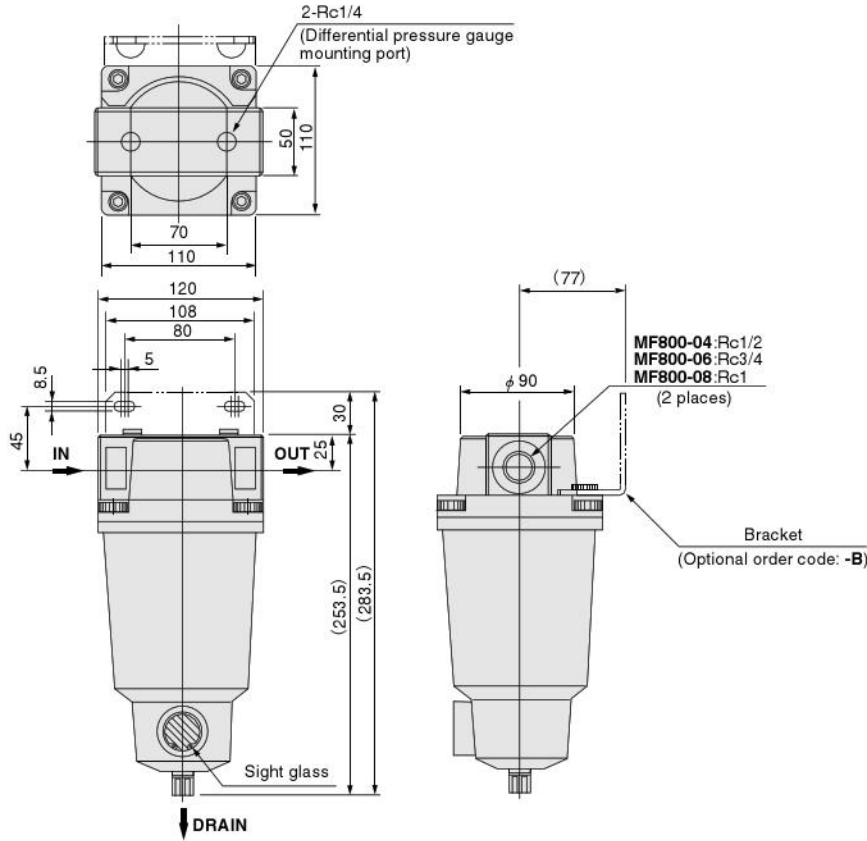

MF1000

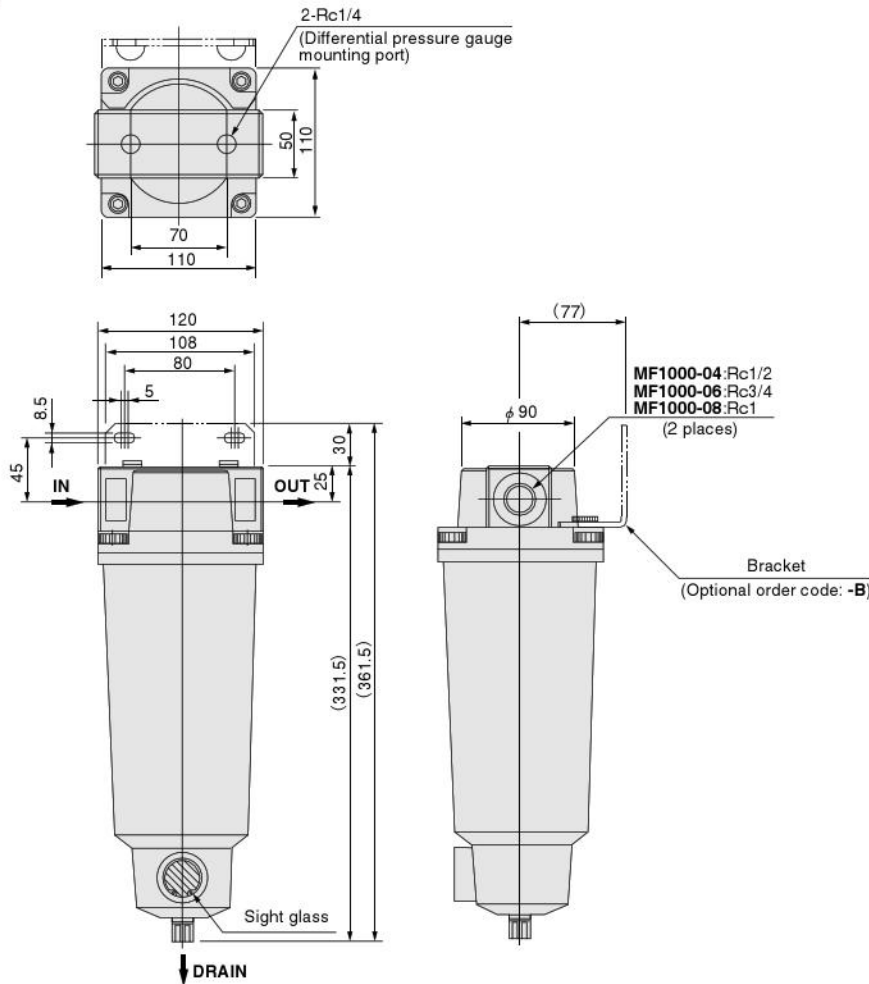

MICRO MIST FILTERS

MMF600, MMF800

Symbol

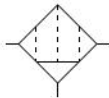

Specifications

Item	Model	MMF600	MMF800
Media		Air	
Port size	Rc	1/2, 3/4, 1	
Filtering particle diameter	μm	0.01	
Filtering efficiency	%	99.9	
Volume of processed air ¹⁾	ℓ/min [ft^3/min] (ANR)	3000 [106]	5000 [177]
Max. operating pressure	MPa [psi.]	0.97 [141] (Auto drain type: 0.15~0.97 [22~141])	
Proof pressure	MPa [psi.]	1.47 [213]	
Operating temperature range (atmosphere and media)	$^{\circ}\text{C}$ [$^{\circ}\text{F}$]	5~60 [41~140]	
Drain capacity	cc [in. ³]	160 [9.8]	
Mass	kg [lb]		
	Standard	1.69 [3.72]	2.05 [4.52]
	Auto drain type	1.72 [3.79]	2.08 [4.59]
Materials	Body, bowl	Aluminum die-casting	
	Sight glass	Reinforced glass	
	Element type	E-60MM	E-80MM
Standard attachments		Screw type drain cock	

Note: This is the recommended maximum flow rate when the air pressure is 0.69MPa [100psi.].

Order Codes

MMF - - -

Bracket
Blank — No bracket
B — With bracket¹⁾

Note: For the bracket order codes and dimensions, see p.151 ~ 152.

Drain cock specification
Blank — Screw type drain cock
F1 — Drain cock with fitting (Standard for auto drain type)
A — Auto drain type drain cock

Body model	Port size		
	Rc1/2	Rc3/4	Rc1
600	04	06	08
800	04	06	08

Micro mist filter

Inner Construction

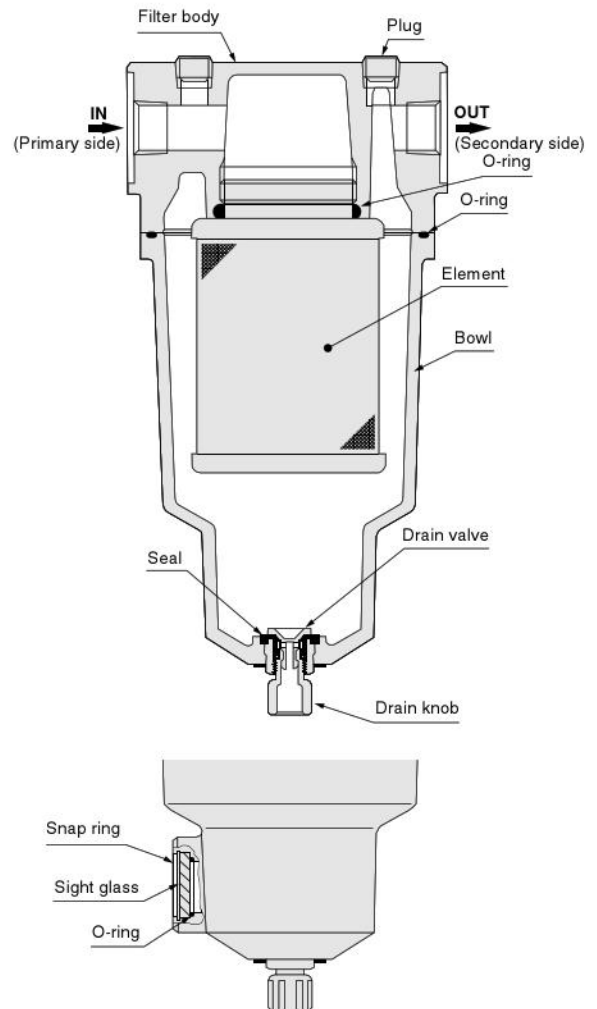

Flow Rate Characteristics

MMF600

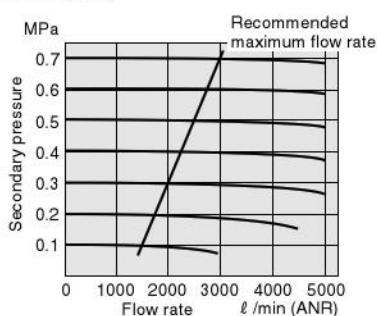

MMF800

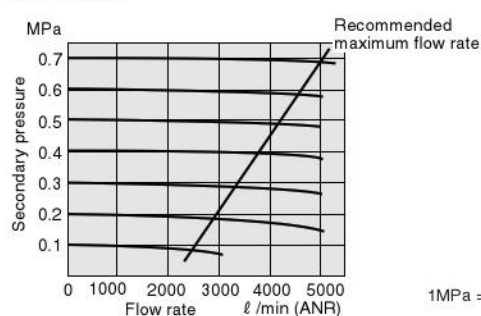

1MPa = 145psi. 1ℓ/min = 0.0353ft³/min.

Dimensions of Micro Mist Filters (mm)

MMF600

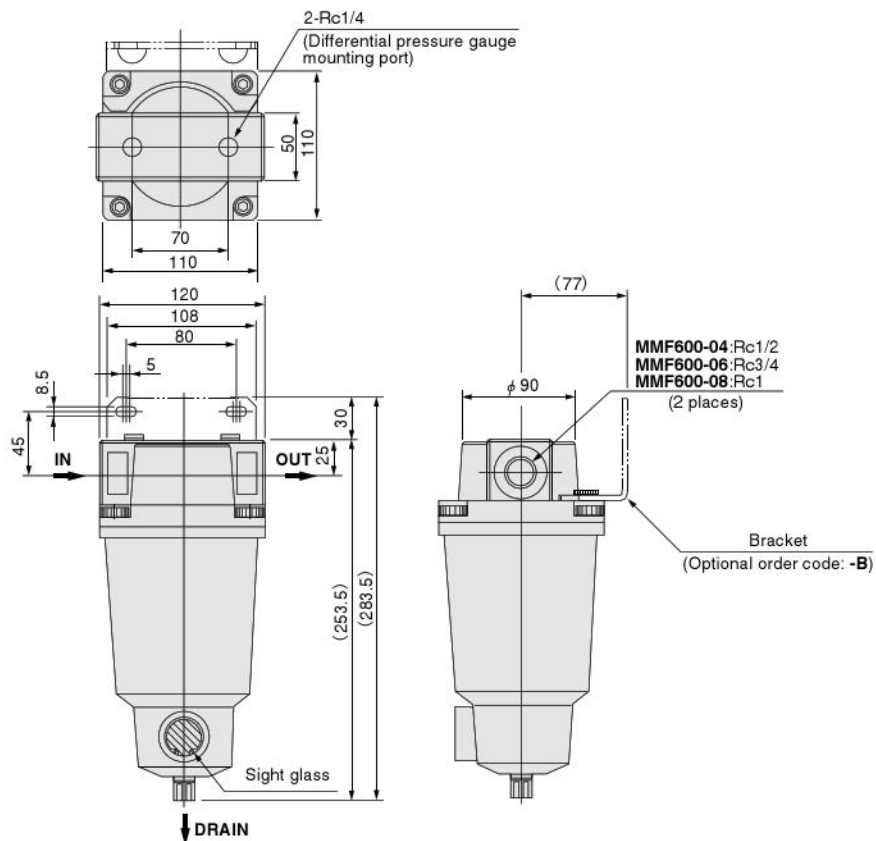

F.R.L. LARGE FLOW SERIES

MMF800

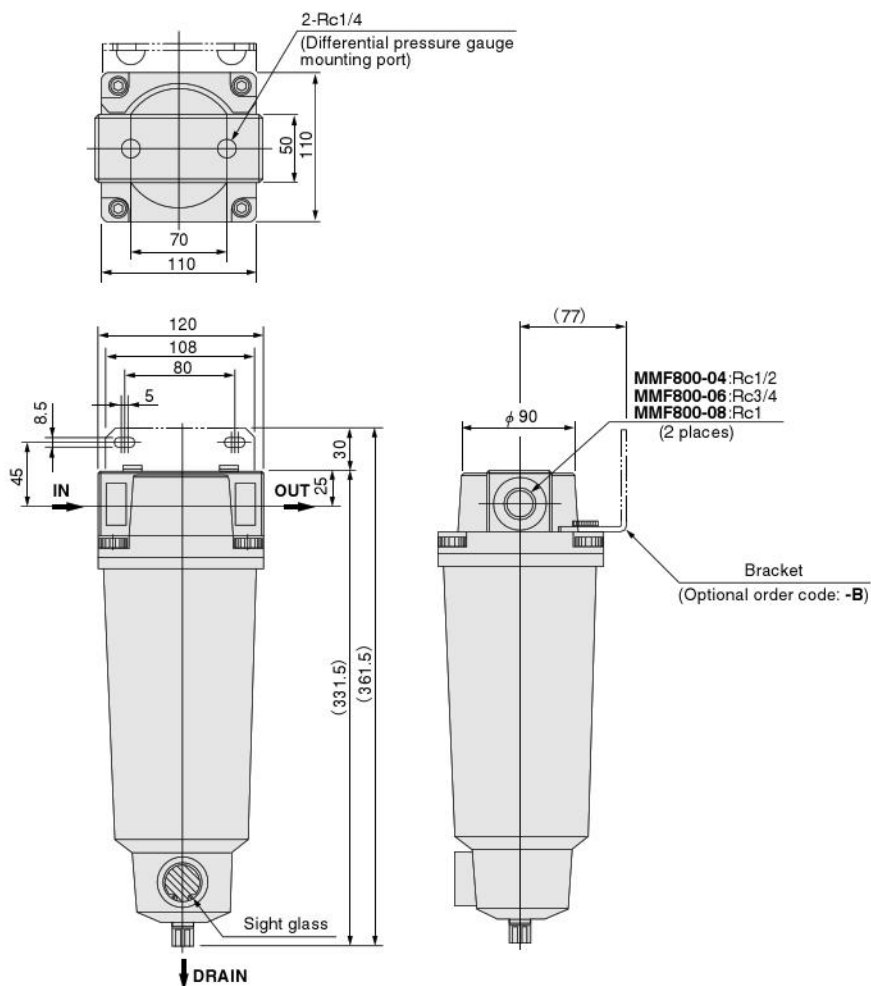

REGULATORS

RN650, RN651, RN652, RN900, RN902

Symbols

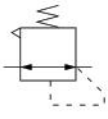

- Standard specification
- Low pressure specification

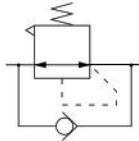

- Built-in check valve specification



Specifications

Item	Series	650 series			900 series		
		Type	Standard	Low pressure	Built-in check mechanism	Standard	Built-in check mechanism
		Model	RN650	RN651	RN652	RN900	RN902
Media		Air or non-corrosive gas					
Port size	Rc	3/4, 1					
Pressure setting range	MPa [psi.]	0.05~0.83 [7~120]	0.05~0.25 [7~36]		0.05~0.83 [7~120]		
Max. operating pressure	MPa [psi.]	0.97 [141]					
Proof pressure	MPa [psi.]	1.47 [213]					
Operating temperature range	°C [°F]	5~60 [41~140]					
Pressure gauge connection port	Rc	1/4 (2 places)					
Construction		Relieving type					
Max. processed flow rate ^{Note}	ℓ/min [ft ³ /min] (ANR)	2500 [88]	1500 [53]	2500 [88]	8000 [282]		
Lubrication		Not required					
Mass	kg [lb.]	0.53 [1.17]			1.26 [2.78]		
Materials	Body	Aluminum die-casting					
	Bonnet	Polyacetal			Aluminum die-casting		
	Knob	ABS			PBT		
	Diaphragm	Synthetic rubber with layer cloth					
Standard attachments	Bracket	Standard attachments					
	Mounting ring	Standard attachments					
Embedded pressure gauge	Pressure indicator range	MPa [psi.] 1 [145]					
	Max. operating pressure	MPa [psi.] 0.95 [138]					
	Operating temperature range	°C [°F] 5~60 [41~140]					
	Materials	Bourdon tube	Brass tube				
Cover (case)		PPS					
Digital pressure gauge with built-in sensor	Rated pressure range	MPa [psi.] 0~1.000 [0~145]					
	Setting pressure range	MPa [psi.] 0~1.000 [0~145]					
	Materials	Case ABS					

Note: This is the maximum processed flow rate when the air primary pressure is 0.69MPa [100psi.] and the secondary setting pressure is 0.5MPa [73psi.].

Order Codes

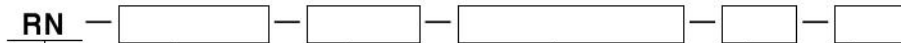

Regulator

Body model

Port size

Non-ion specification

Blank — Standard specification

NCU — Non-ion specification

Bracket specification^{Note3}

Blank — Mounting bracket

BR — Bracket module (only for 900 series)

BM — Module for supporting piping (only for 900 series)

Pressure gauge specification

Blank — No pressure gauge

G1A — 1MPa [145psi.] specification, ϕ 40 pressure gauge^{Note1}

G1B — 1MPa [145psi.] specification, \square 30 Embedded pressure gauge (only for 900 series)^{Note2}

G3 — 0.3MPa [44psi.] specification, ϕ 40 pressure gauge (only for 650 series)^{Note1}

GS1A — 1MPa [145psi.] specification, \square 50 Pressure gauge with built-in switch, lead wire type for DC24V^{Note1}

GS1B — 1MPa [145psi.] specification, \square 50 Pressure gauge with built-in switch, lead wire type for AC100V, AC200V^{Note1}

GS1C — 1MPa [145psi.] specification, \square 50 Pressure gauge with built-in switch, with DIN connector for DC24V^{Note1}

GS1D — 1MPa [145psi.] specification, \square 50 Pressure gauge with built-in switch, with DIN connector for AC100V, AC200V^{Note1}

GS2 — 1MPa [145psi.] specification, \square 30 Digital pressure gauge with built-in sensor, (only for 900 series)^{Note2}

Notes: 1. For the specifications, order codes, and dimensions of the pressure gauge and the pressure gauge with built-in switch, see p.172 and 183.
2. If a non-ion specification is selected, note that **-G1B** and **-GS2** cannot be selected.
3. For the bracket and module order codes and specifications, see p.147~152.

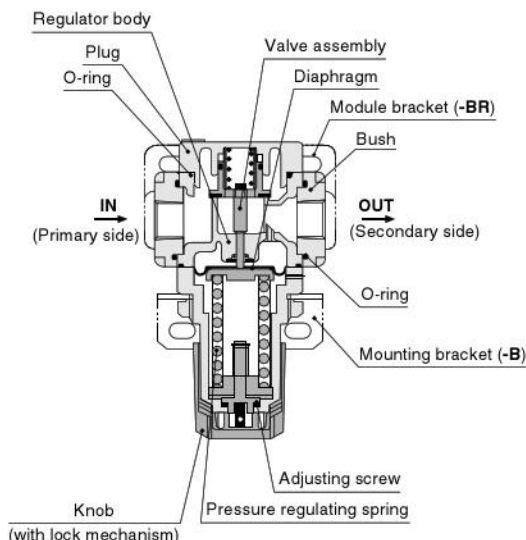

Flow Rate Characteristics

● Standard and built-in check mechanism specifications

**RN650
RN652**

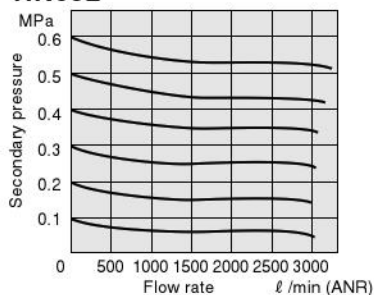

**RN900
RN902**

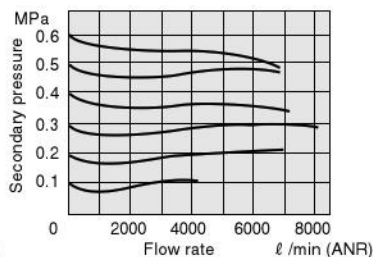

● Low pressure specification

RN651

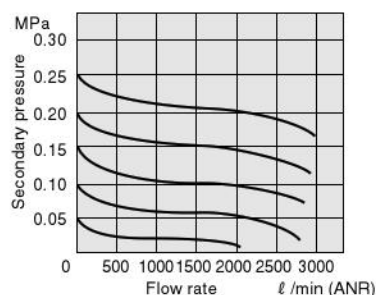

Pressure Characteristics

Remark: Graphs show flow rate characteristics when the primary pressure is at 0.7MPa [102psi]. 1 l/min = 0.0353ft³/min.

● Standard and built-in check mechanism specifications

**RN650
RN652**

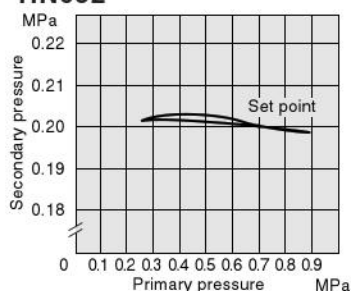

**RN900
RN902**

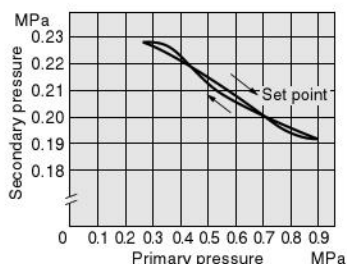

● Low pressure specification

RN651

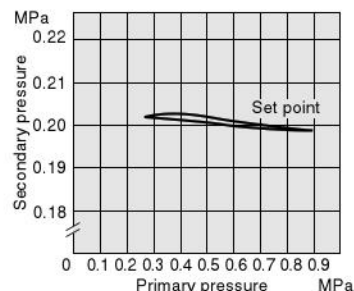

1MPa = 145psi.

System Upgrade Using a Regulator with Built-in Check Mechanism

The regulator with built-in check mechanism is equipped with a built-in check valve that opens up when the primary pressure falls off, causing the pressure balance to collapse and simultaneously opening up the main valve to relieve the secondary pressure to the primary side.

Changing push side and pull side thrust

The thrust on an air cylinder's push side and pull side can be changed easily. Cylinders can be operated at low pressure on the side where thrust is not required, allowing reduction of air consumption.

Example: More thrust on push side, less thrust on pull side
Push side air pressure: 0.5MPa
Pull side air pressure: 0.3MPa

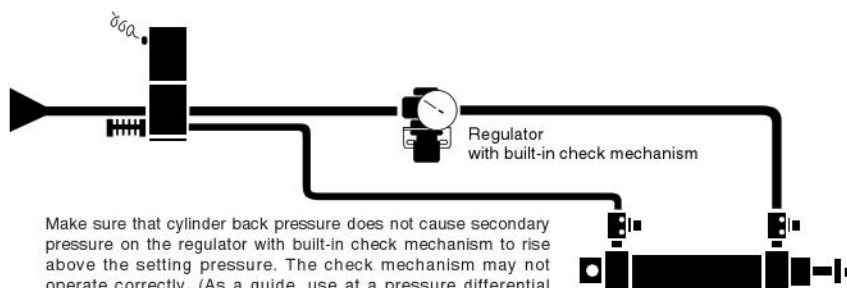

Make sure that cylinder back pressure does not cause secondary pressure on the regulator with built-in check mechanism to rise above the setting pressure. The check mechanism may not operate correctly. (As a guide, use a pressure differential between the push and pull sides of 0.3MPa or less.)

Dimensions of Regulators (mm)

- RN650
- RN651
- RN652

● Optional pressure gauges  RN650

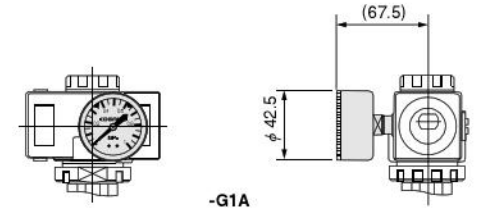
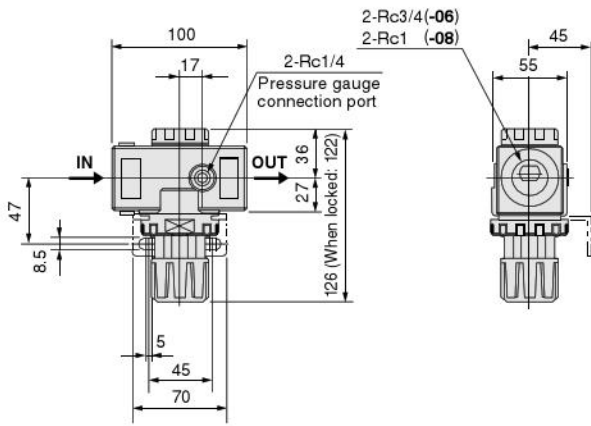

-G1A
-G3

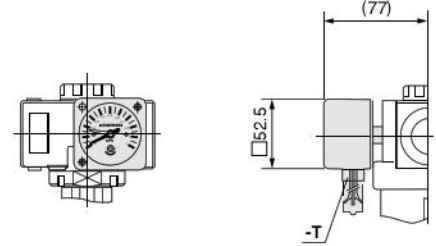

-GS1□

- RN900
- RN902

 RN900

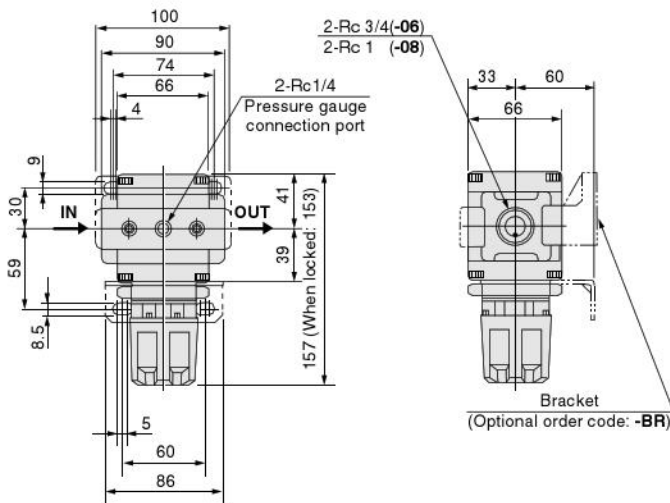

● Optional pressure gauges

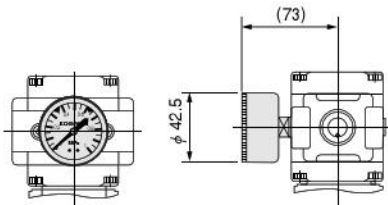

-G1A

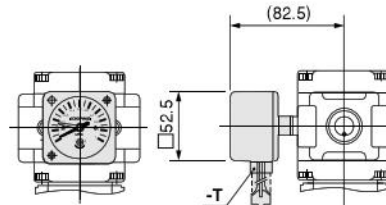

-GS1A□

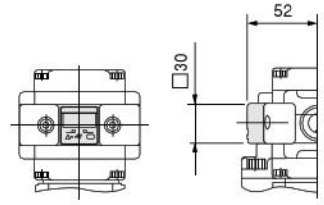

-GS2

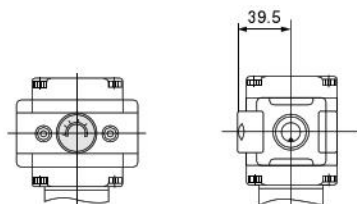

-G1B

LUBRICATORS

LN650, LN651, LN900, LN901, LN902

Symbol



F.R.L. LARGE FLOW SERIES

Specifications

Item	Series Type Model	650 series		900 series		
		Standard	Micro lubricator	Standard	Micro lubricator	Machine lubricator
		LN650	LN651	LN900	LN901	LN902
Media		Air or non-corrosive gas				
Port size	Rc	3/4, 1				
Max. operating pressure	MPa [psi.]	0.97 [141]			0.3 [44]	
Proof pressure	MPa [psi.]	1.47 [213]				
Operating temperature range	°C [°F]	5~60 [41~140]				
Oil capacity	cc [in. ³]	160 [9.8]				
Recommended lubrication		Turbine oil Class 1 [ISO VG32]				
Lubrication method		Total lubrication	Selective lubrication	Total lubrication	Selective lubrication	Selective lubrication
Min. flow rate for dripping oil	ℓ./min [ft ³ /min] (ANR)	20 [0.71]	70 [2.47]	155 [5.47]	185 [6.53]	14 [0.49]
Mass	kg [lb.]	0.64 [1.4]		1.3 [2.9]		1.4 [3.1]
Materials	Body	Aluminum die-casting				
	Bowl	Polycarbonate				
	Damper	Urethane rubber				
Standard attachments		Bowl guard				

Order Codes

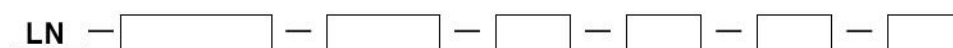

Lubricator

Body model

Port size
Rc3/4 Rc1

Non-ion specification
Blank — Standard specification
NCU — Non-ion specification

650 — 06 08 — Standard specification
900 — 06 08 — Standard specification
651 — 06 08 — Micro lubricator
901 — 06 08 — Micro lubricator
902 — 06 08 — Machine lubricator

Bracket specification
Blank — No bracket
B — With bracket^{*)}

Note: For the bracket order codes and dimensions, see p.151 ~ 152.

Drain cock specification
Blank — Drain cock
D — Screw type drain cock
F2 — Drain cock with fitting

Bowl specification
Blank — Standard specification (Polycarbonate)
N — Nylon bowl

Inner Construction

● Standard

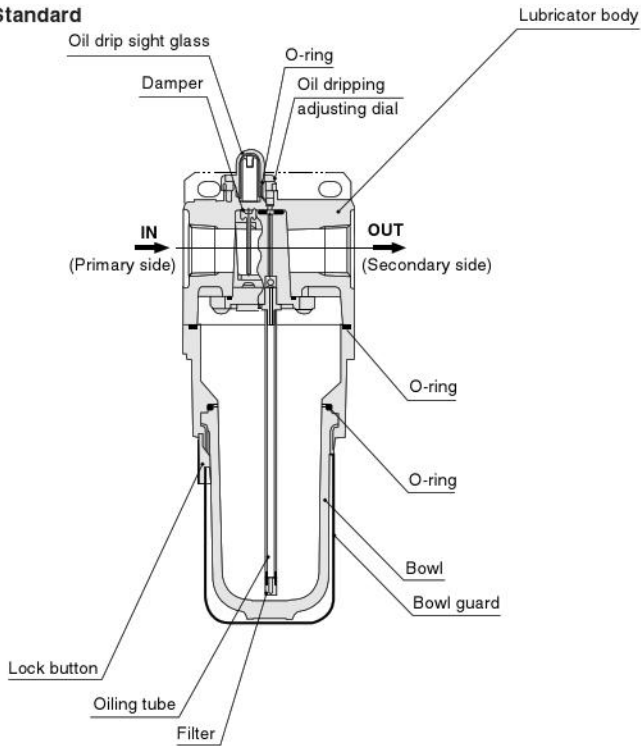

● Micro lubricator

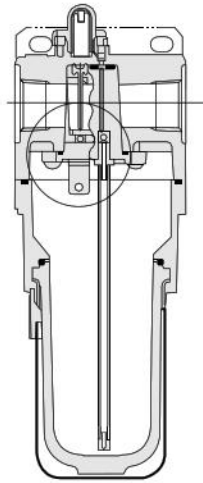

● Machine lubricator

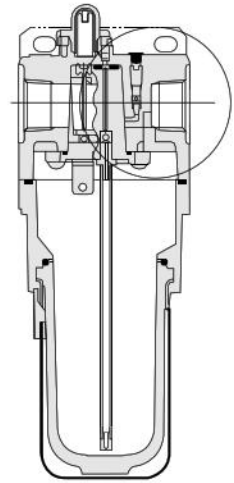

Note: Circled areas show the section that vary from the standard model.

Flow Rate Characteristics

● LN650 ● LN651

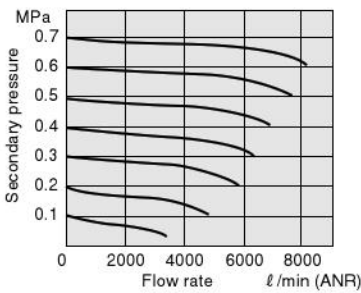

● LN900 ● LN901

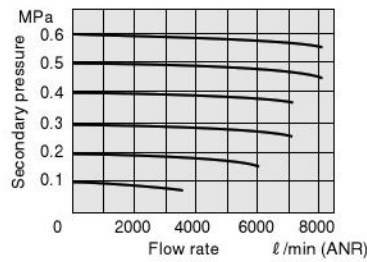

● LN902

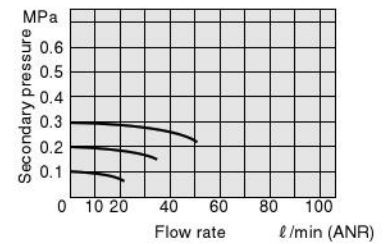

1MPa = 145psi. 1 ℓ/min = 0.0353ft³/min.

Minimum Flow Rate for Dripping Oil

● Standard

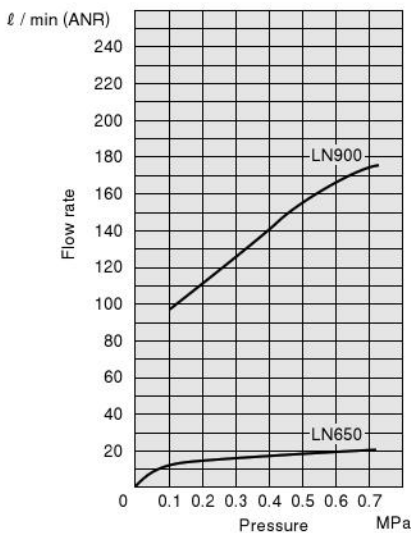

● Micro lubricator

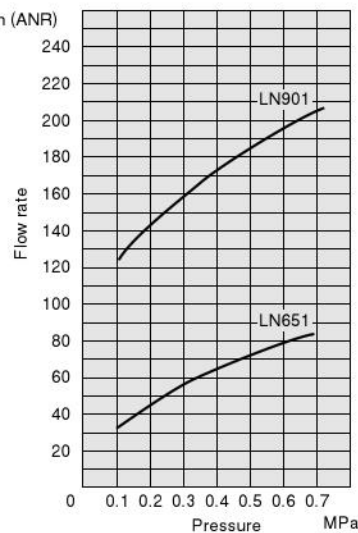

● Machine lubricator

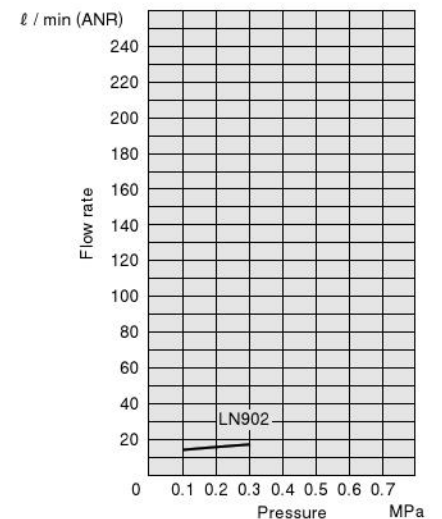

1MPa = 145psi. 1 ℓ/min = 0.0353ft³/min.

Dimensions of Lubricators (mm)

- LN650
- LN651



LN650

- LN900
- LN901
- LN902



LN900

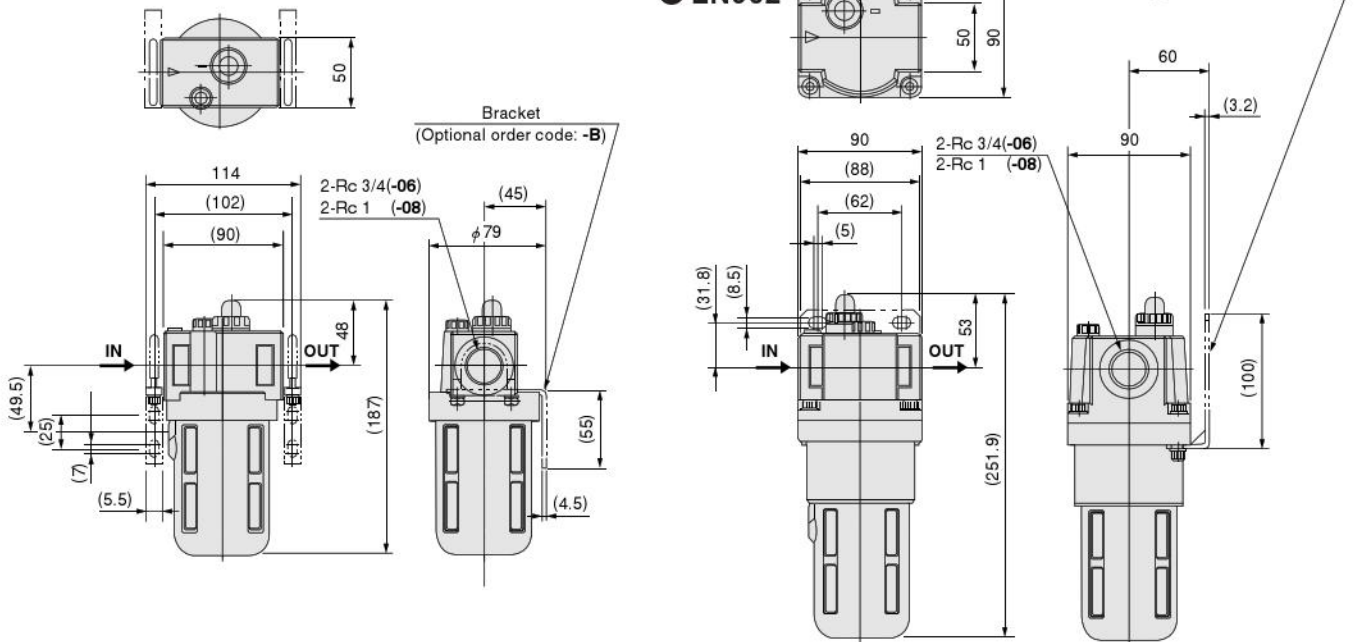

F.R.L. LARGE FLOW SERIES

System Upgrade Using a Micro Lubricator

The Micro Lubricator uses a pipe and nozzle to generate an oil mist inside the bowl, and supplies only the most finely microscopic mist to delivery side.

The micro mist is carried easily on the air flow, to ensure faster, more assured lubrication. This method is effective even when the piping distance to the actuator is unusually far or piping is subject to complex twists and turns, or when the actuator is mounted in a high position.

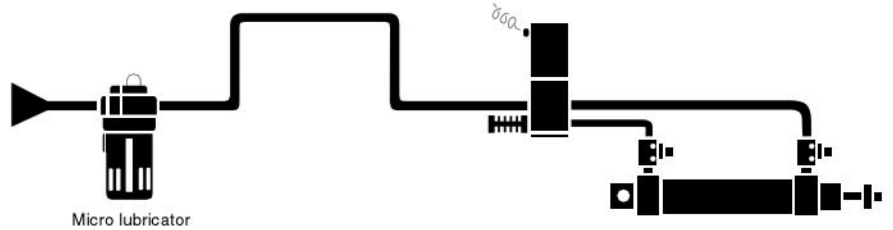

System Upgrade Using a Machine Lubricator (LN-902)

Machine lubricators are dedicated devices used in lubrication lines to supply a fine oil mist of $2\mu\text{m}$ or less to the sliding or wearing areas of bearings, gears, chains, cams, and slide parts in all types of machine tools.

With just the right amount of oil being continuously lubricated, the system effectively cools, lubricates, and cleans the sliding and wearing areas, extending the machine's operating life.

Air is used at 0.3MPa [44psi.] and 60 ℓ/min [2.1ft³/min] (ANR) or less, which means that these devices cannot be directly used in pneumatic equipment that are based on air as the energy source. Because the carried oil mist is a fine, dry fog, it can easily supply oil through long piping distances to the areas requiring oil without adhering to the inner walls of the piping, a situation that ordinary lubricators cannot handle. For more effective lubrication, however, consideration should be given to the prevention of turbulence in the air lines due to installation of fittings, etc., and the piping should be installed as straight as possible.

To ensure that the lubrication oil adheres to the area being required, a lubrication nozzle is needed to convert the carried oil mist (dry fog) into a wet mist that adheres more easily.

The lubrication nozzle can be built directly into the mechanical devices that directly supply oil. For machining or manufacturing, see the orifice dimensions table to the right for nozzle dimensions corresponding to the oil supply volume.

mm [in.]				
Lubrication amount cc [in ³]/H	Number of drops Drops/H	ϕ d	ℓ	Nozzle dimension
0.3 [0.018]	150	0.7 [0.028]	4 [0.16]	<p>Note: Outward appearance is not limited to configuration shown here.</p>
0.6 [0.036]	300	1.0 [0.039]	6 [0.24]	
0.9 [0.055]	450	1.2 [0.047]	8 [0.31]	
2.4 [0.146]	900	1.6 [0.063]	10 [0.39]	

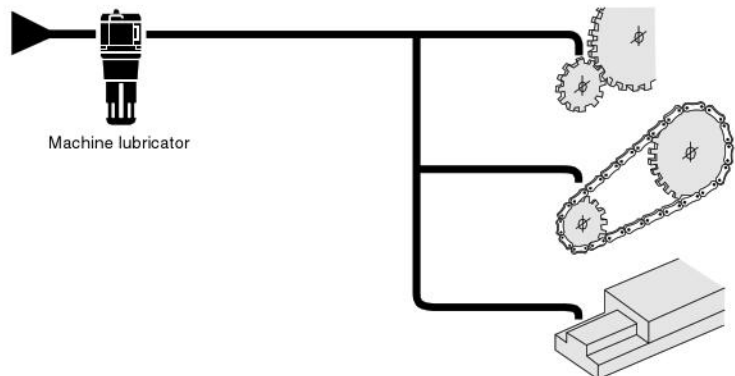

MODULES AND ADAPTERS

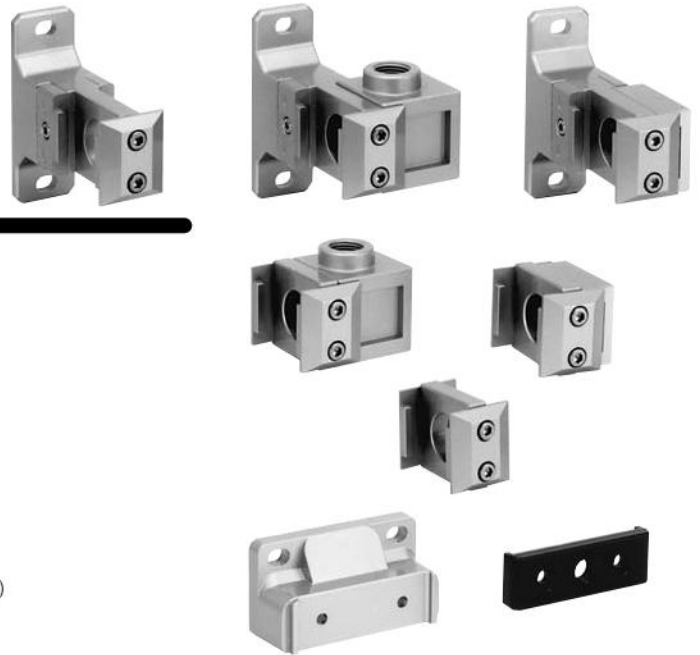

Order Codes

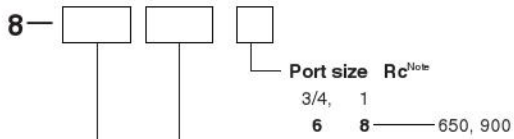

Module and adapter









- F — F module
- ND — D module for bracket-combined use
- T — T module
- DT — T module for bracket-combined use
- R — R module (For regulator only)
- M — Piping supporting type M module (For regulator only)
- S — S adapter
- DS — S adapter module

Body size

- 65 — For 650 series
- 90 — For 900 series

Note: Port size selection is not allowed for F module (F), D module for bracket-combined use (ND), R module (R), and piping supporting type M module (M).

Model List

Modules and adapters	F module	D module	T module	
	F	ND	T	DT
Body size	 (For modules only)	 (Brackets for combined use)	 (Branch piping)	 (Brackets for combined use with branch piping)
65	8-65F ● Applicable model FN650 RN650, RN651, RN652 LN650, LN651 FN900, FN901 LN900, LN901, LN902	8-65ND ● Applicable model CN650, CY650, CN750 FN650 RN650, RN651, RN652 LN650, LN651 FN900, FN901, LN900, LN901, LN902	8-65T ● Applicable model FN650 RN650, RN651, RN652 LN650, LN651 FN900, FN901 LN900, LN901, LN902	8-65DT ● Applicable model FN650 RN650, RN651, RN652 LN650, LN651 FN900, FN901 LN900, LN901, LN902
90		8-90ND ● Applicable model CZ650 MF800, MF1000 MMF600, MMF800		8-90DT ● Applicable model MF800, MF1000 MMF600, MMF800
Modules and adapters	R module	M module	S adapter	
	R	M	S	DS
Body size	 (For regulator only)	 (For supporting regulator piping only)	 (Port connection)	 (Brackets for combined use with piping connection)
65	—	—	8-65S ● Applicable model FN650 RN650, RN651, RN652 LN650, LN651 FN900, FN901 LN900, LN901, LN902	8-65DS ● Applicable model FN650 RN650, RN651, RN652 LN650, LN651 FN900, FN901 LN900, LN901, LN902
90	8-90R ● Applicable model CN900 CY900 CZ900 RN900, RN902	8-90M ● Applicable model RN900, RN902		8-90DS ● Applicable model MF800, MF1000 MMF600, MMF800

Remark: The applicable models shown in the tables are typical examples. For details, see p.125.

Dimensions of F Module (mm)

● 8-65F

CAD Frl_mod

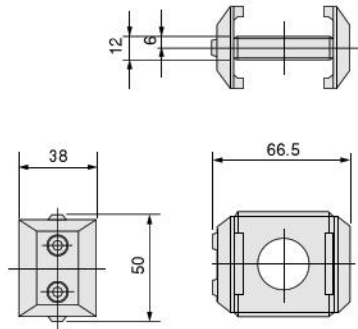

Dimensions of D Module for Bracket-combined Use (mm)

● 8-65ND

CAD Frl_mod

● 8-90ND

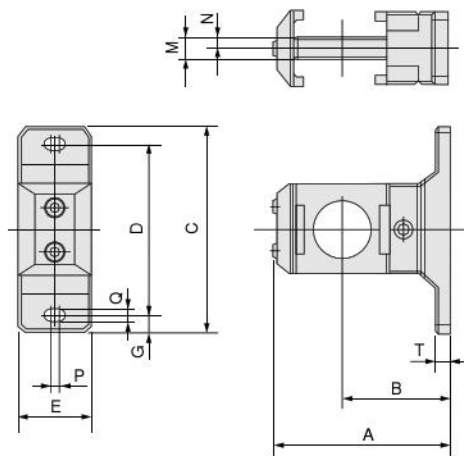

Model	A	B	C	D	E	G	M	N	P	Q	T
8-65ND	94	60	110	90	38	10	12	6	4	9	8
8-90ND	111	77	110	90	38	10	12	6	4	9	7

Dimensions of T Module (mm)

● 8-65T

CAD Frl_mod

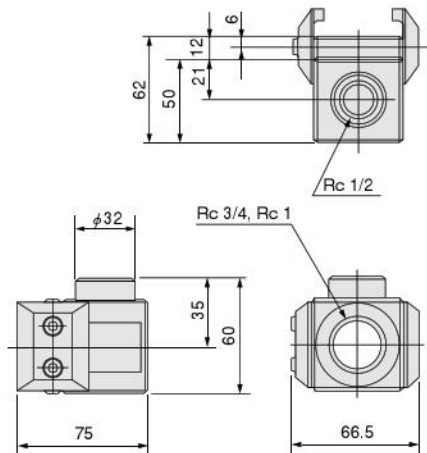

Dimensions of T Module for Bracket-combined Use (mm)

- 8-65DT
- 8-90DT

CAD FrL_mod

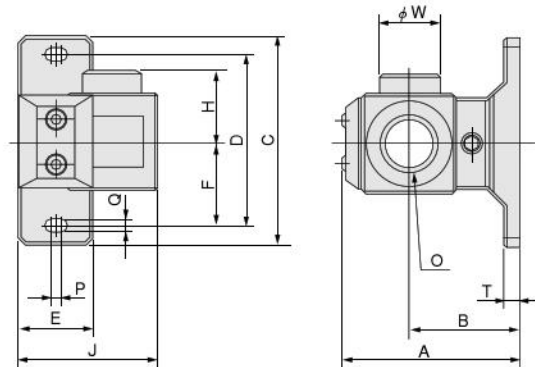
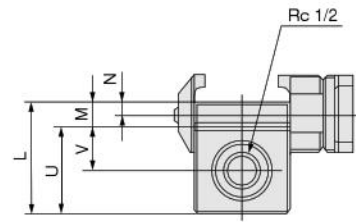

Model	A	B	C	D	E	F	H	J	L	M	N	O	P	Q	T	U	V	φW
8-65DT	94	60	110	90	38	45	35	75	62	12	6	Rc3/4 Rc1	4	9	8	50	21	32
8-90DT	111	77	110	90	38	45	35	75	62	12	6	Rc3/4 Rc1	4	9	7	50	21	32

Dimensions of R Module (For Regulator Only) (mm)

- 8-90R

CAD FrL_mod6

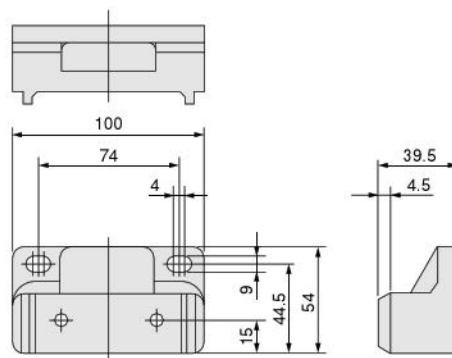

Dimensions of Piping Supporting Type M Module (mm)

- 8-90M

CAD FrL_mod6

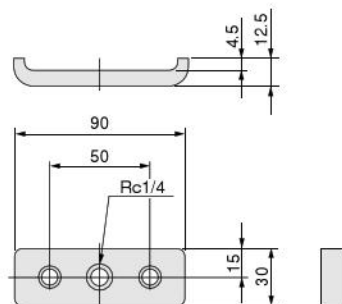

Dimensions of S Adapter (mm)

● 8-65S

CAD Frl_mod5

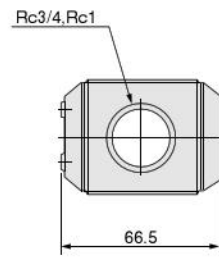
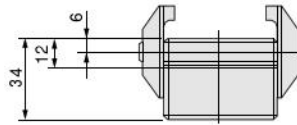
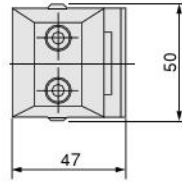

Dimensions of S Adapter Module (mm)

● 8-65DS
● 8-90DS

CAD Frl_mod

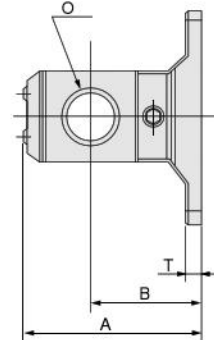
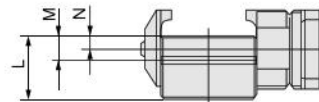
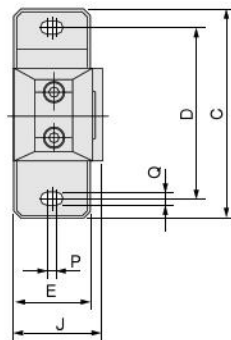

Model	A	B	C	D	E	J	L	M	N	O	P	Q	T
8-65DS	94	60	110	90	38	47	34	12	6	Rc3/4 Rc1	4	9	8
8-90DS	111	77	110	90	38	47	34	12	6	Rc3/4 Rc1	4	9	7

BRACKETS



Bracket Models and Applicable Component

Component type		Bracket model	Remark
Air filters	FN650	8-65B ^{Note}	Piping supporting type, optional
	FN900	8-90A	Body supporting type, optional
Mist filters	MF800	8-80A	Body supporting type, optional
	MF1000		
Micro mist filters	MMF600	8-80A	Body supporting type, optional
	MMF800		
Regulators	RN650	8-65	Standard
	RN900	8-90	
Lubricators	LN650	8-65B ^{Note}	Piping supporting type, optional
	LN900	8-90A	Body supporting type, optional

Note: Pipe supporting type brackets (8-65B) are sold in a set of two brackets.

Dimensions of Brackets (mm)

■ For air filters, mist filters, micro mist filters, and lubricators

● 8-80A

● 8-90A

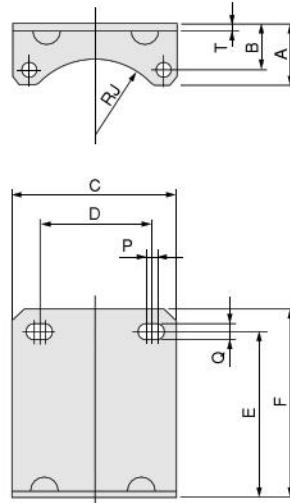

Model	A	B	C	D	E	F	RJ	P	Q	T	Applicable model
8-80A	50	32	108	80	70	80	47	5	8.5	3.2	MF800, MF1000, MMF600, MMF800
8-90A	31	23	88	62	90	100	42	5	8.5	3.2	FN900, FN901, LN900, LN901, LN902

■ For air filters and lubricators

● 8-65B Note



Note: Pipe supporting type brackets (8-65B) are sold in a set of two brackets.

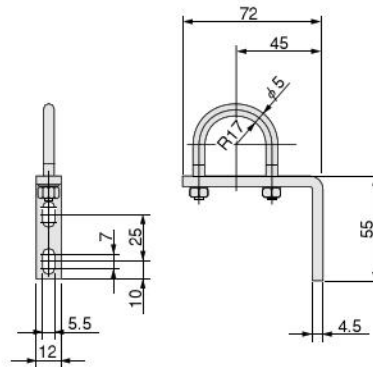

■ For regulators

● 8-65

● 8-90

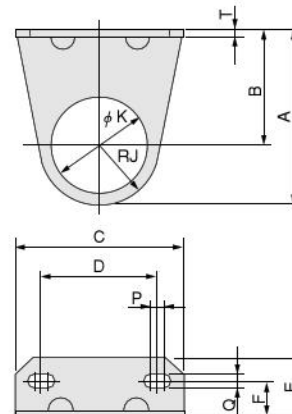

Model	A	B	C	D	E	F	RJ	φ K	P	Q	T	Applicable model
8-65	72.5	45	70	45	30	20	27.5	45	5	8.5	3.2	RN650, RN651, RN652
8-90	91	60	86	60	30	20	31	52.5	5	8.5	3.2	RN900, RN902

Handling Instructions and Precautions



F.R.L. Combinations

Installation location

1. Install in locations where the ambient temperature is between 5 ~ 60°C [41 ~ 140°F].
2. The product cannot be used when the media or the ambient atmosphere contains any of the substances listed below.
Organic solvents, phosphate ester type hydraulic oil, sulphur dioxide, chlorine gas, acids, or alkali, etc.
3. Avoid installation in locations subject to vibrations greater than 9.8m/s² [1G].

Mounting method

Mount in a vertical position, with the piping connections on the top and the bowl on the bottom.
(If using regulators as single units, any mounting direction is acceptable.)
Leave enough space underneath the bowl to allow easy access for draining collected liquid, and replacement of the filter element.

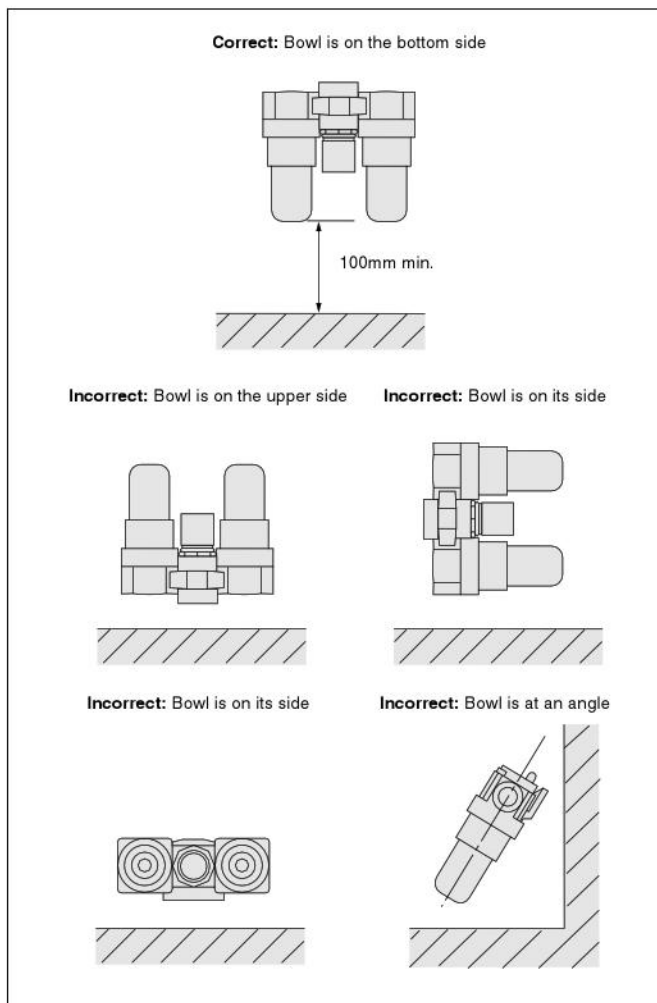

- Notes:
1. Do not perform any machining on the body of the unit before or during mounting work. Its functions could be damaged.
 2. Use air for the media.
 3. Do not allow operating pressure to exceed a maximum of 0.97MPa [141psi].
 4. If using in locations subject to dripping water, dripping oil, etc., or to large amounts of dust, use something to cover and protect the unit.

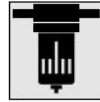

Air Filter and Lubricator

Drain cock

● Screw type

(Air filter Standard Order code: -A)
(Lubricator Order code: -D)

Rotating the drain knob to the left opens the drain port, and the collected liquid is expelled.

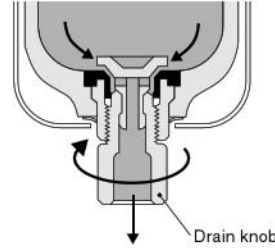

● With fitting

(Air filter Order code: -F1)
(Lubricator Order code: -F2)

Rotating the drain knob to the left opens the drain port, and the collected liquid is expelled.

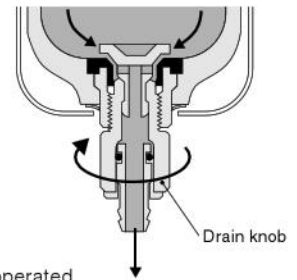

Caution: The drain knob should be operated using fingertips.

● Auto drain type

(Air filter Order code: -A)

When a certain volume of collected liquid has accumulated, or when the pressure inside the bowl has fallen to less than 0.02MPa [3psi.], the collected liquid is automatically expelled. The collected liquid may also be expelled manually by turning the drain knob to the left.

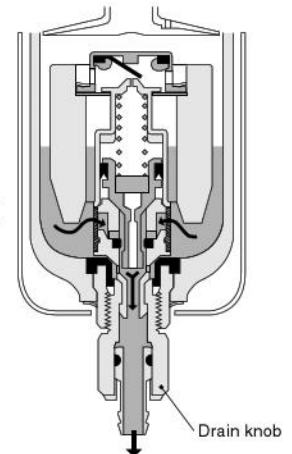

1. In the auto drain, air is exhausted from the drain port until the supply pressure reaches 0.15MPa [22psi.]. This is normal, and even rotating the drain knob in this situation will not prevent the air from bleeding out.
(If the time required for the supply pressure to rise to 0.15MPa [22psi.] seems too long, consult us.)
2. The drain knob should be operated using fingertips.
3. If attaching a tube to the fitting, use a nylon tube with inner diameter of 6mm [0.236in.]. Do not let the tube bend in the area near the fitting connection.
4. The fitting can be rotated freely in any direction. As a result, the tube does not need to be removed even when manually draining the collected liquid.

When placing orders for replacement of pressure gauges, see the table below.

Model	Optional order code	Sold separately	Module sold separately
650 750	G1A	G1-40	—
	GS1A	GS1-50-DL	
	GS1B	GS1-50-AL	
	GS1C	GS1-50-DL-T	
900	GS1D	GS1-50-AL-T	8-90M (with bolt)
	G1A	G1-40	
	GS1A	GS1-50-DL	
	GS1B	GS1-50-AL	
	GS1C	GS1-50-DL-T	
	GS1D	GSS1-50-AL-T	

Remark: If switching between G1A and GS1□, module (8-90M) is not required.