

# Tube Dryers

With hollow fiber membrane for dehumidifying compressed air

## Features

- **No power supply required, no exhaust heat**

Air dryer using hollow fiber membrane is gentle on the global environment. Absolutely no power supply required.

- **Compact, lightweight, large flow rate**

Processed air flow rate: FDH-015 15 ℓ /min [0.53 ft.<sup>3</sup>/min.] (ANR)  
FDH-030 30 ℓ /min [1.06 ft.<sup>3</sup>/min.] (ANR)

- **Generates no condensation**

Since the removed moisture is exhausted as water vapor, there is no need to equip drain port.

- **With dew point indicator**

Installed a dew point indicator enabling checks of dehumidification conditions in real time.

- **Standard can be used as non-lubrication specification**

- **Uses fluoro rubber for the sealing parts**

### Flow direction mark

For use, align the air flow direction to the arrow.

### IN port

Quick fitting -J6 for  $\phi$  6 tube  
-J8 for  $\phi$  8 tube

### Purged air piping port

Water vapor separated by the hollow fiber membrane is exhausted here together with the purged air.

M5 × 0.8

Note: Do not block.

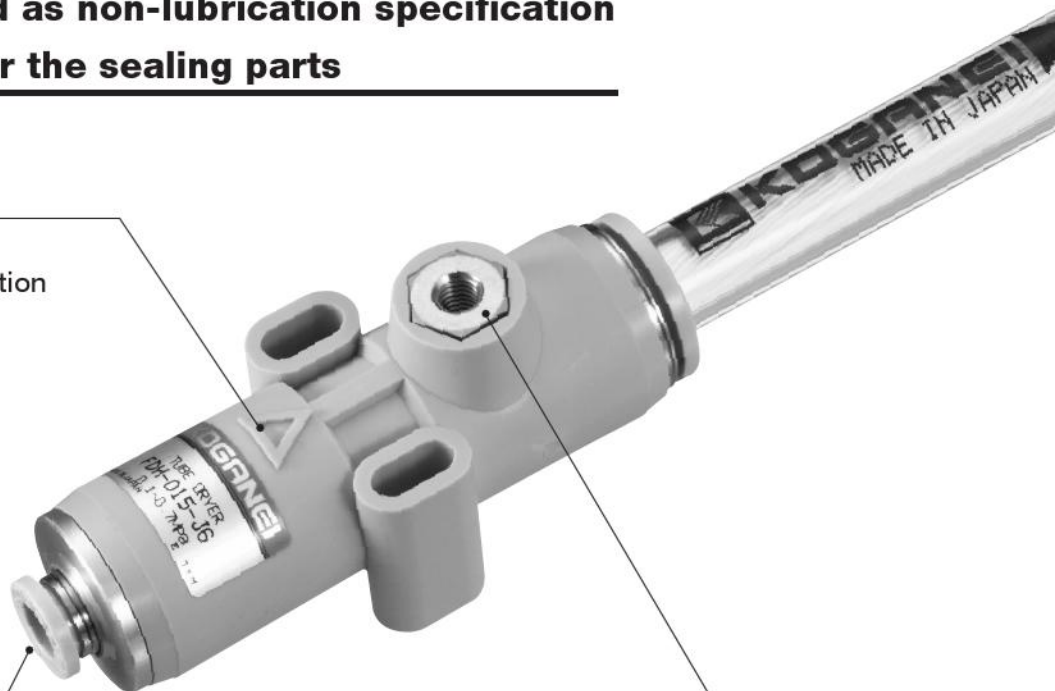

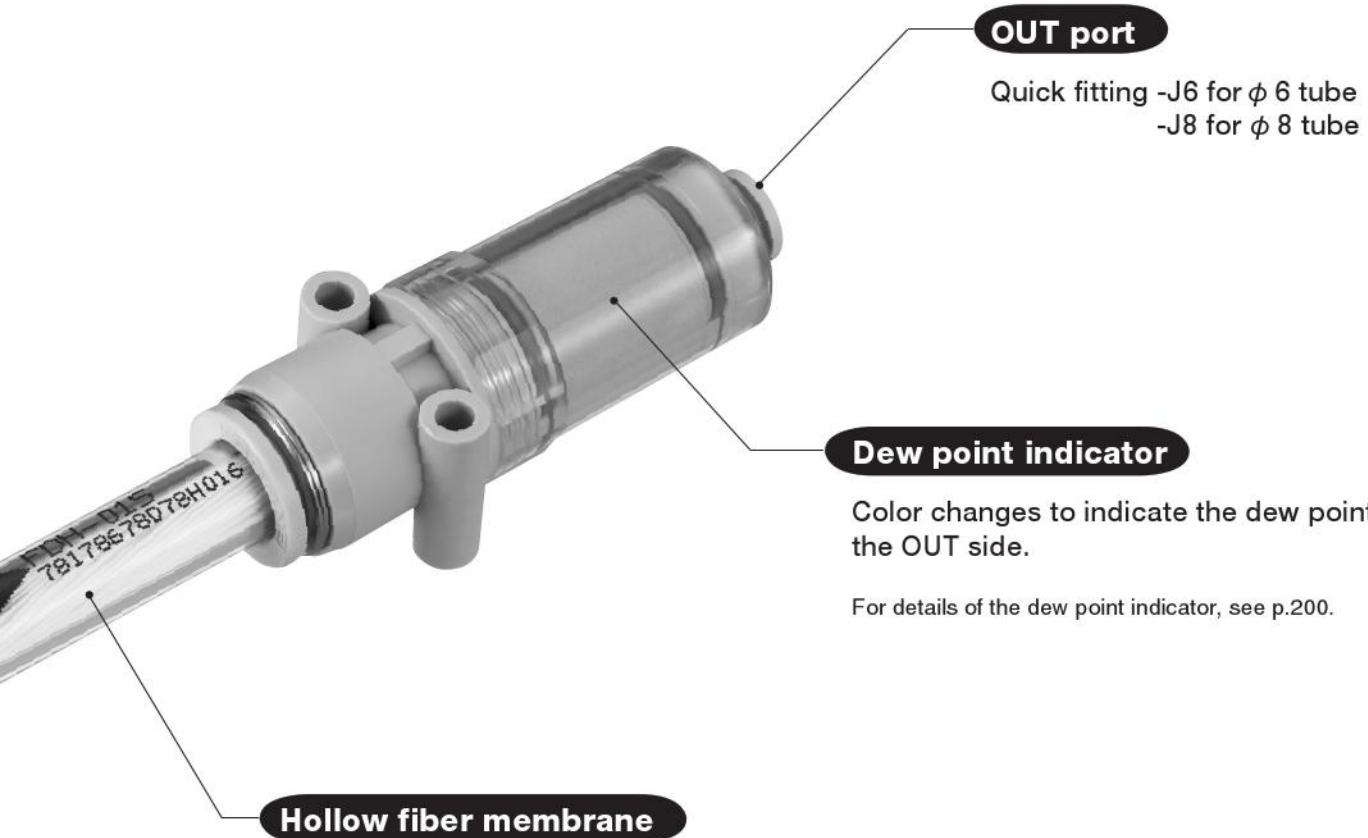

Separates water vapor in the compressed air.

### Dehumidification principles

The difference in water vapor pressure between the inside and outside of the hollow fiber membrane causes water vapor in the compressed air to be transmitted through the membrane and exhausted to the outside. This action results in continuous dehumidification of the compressed air.

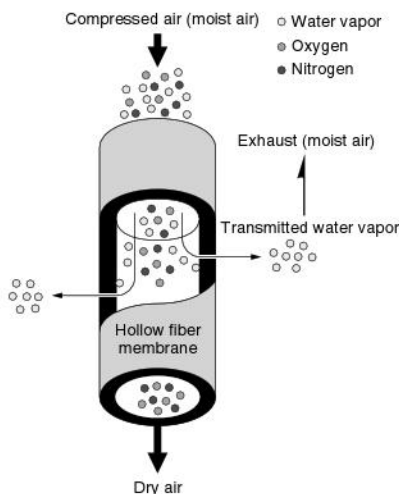

## Safety Precautions (Tube Dryers)

Here follows safety precautions specific to the Tube Dryers. For other safety precautions, be sure to read p.49.

### Warning

- Always check the Catalog and other reference materials for correct product piping.  
Incorrect piping could lead in a short time to a function shutdown, to a drastic deterioration in performance, or to a shortened operating life. It could also lead to abnormal operation in the actuator, etc.
- Do not use with media not shown in the specifications table. Use with non-specification media could lead in a short time to a function shutdown, to a drastic deterioration in performance, or to a shortened operating life.
- Do not bend the tube dryer. Bending it could damage the internal hollow fiber membrane, resulting in product breakdown or function shut down. In addition, when mounting the tube dryer, make sure that there are no curves on the flat surface where it is to be mounted.
- Do not use where the tube dryer or piping tube side can oscillate or rotate. Oscillation or rotation can damage the body.
- Do not use the product where ozone may be generated, such as near ocean beaches or other places subjected to direct sunlight or mercury lamps. Ozone can cause the product to deteriorate, which can lead to degraded performance and functions or to equipment stoppages and a function shutdown.
- Neither use nor store the product in locations that are subject to direct sunlight (ultraviolet rays), dust, salt, iron powder, high temperature and humidity, or in the media and/or the ambient atmospheres that include organic solvents, phosphate ester type hydraulic oil, sulphur dioxide, chlorine gas, acids, etc. It could lead to an early shutdown of some functions or a sudden degradation of performance, and result in a reduced operating life. For materials, see Major Parts and Materials.

## Handling Instructions and Precautions



### General precautions

1. Always thoroughly blow off (use compressed air) the tubing before piping. Entering chips, sealing tape, rust, etc., generated during piping work could result in deterioration in performance and/or functions or a function shutdown.
2. The product cannot be used when the media or the ambient atmosphere contains any of the substances listed below.  
Organic solvents, phosphate acid ester type hydraulic oil, sulphur dioxide, chlorine gas, chlorofluorocarbon, ozone, acids, or corrosive gas.
3. If using in locations subject to dripping water, dripping oil, etc., or to large amounts of dust, use something to cover and protect the unit.
4. After opening the product, do not expose it to a high-temperature or high-humidity environment. It could lead in a short time to a function shutdown, to a drastic deterioration in performance, or to a shortened operating life.

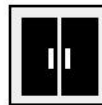

### Storage

- Danger of performance deterioration in high-temperature or high-humidity environment  
Leaving the tube dryer in a high-temperature or high-humidity environment could lead in a short time to a function shutdown or to a drastically shortened operating life. When storing the tube dryer, or when the tube dryer is otherwise not in operation (in a non-pressurized state), keep it in an environment with a relative humidity of 70RH% or less, and temperature of 50°C [122°F] or less.



### Mounting and piping

1. Install in locations where the supplied air and the ambient temperature is 50°C [122°F] or less.
2. If the piping is to be connected directly to the air compressor outlet port, pass it through an aftercooler to keep the air temperature down to 50°C [122°F] or less, and use a filter, mist filter, and micro-mist filter to prevent intrusion of oil mist.
3. Water drops and collected liquid cannot be removed by the tube dryer alone.  
If water drops or collected liquid is intruding, use a filter, mist filter, and micro-mist filter.
4. Leave enough space for easy maintenance.
5. The tube dryer is constantly exhausting purged air through the purged air piping port. Never block the purged air piping port. Blocking will result in loss of function and damage to the body interior. If you do not want to exhaust the purged air into the environment surrounding the tube dryer, attach purged air exhaust piping to the purged air piping port. Do not allow this piping to merge with the compressed air line or the drain piping. It could result in damage to the equipment.
6. Always mount a regulator or throttle valve, etc., on the secondary side of the tube dryer.
7. Plumb the piping so that the air flows in the direction shown by the arrow (flow direction mark) displayed on the product. Sending the flow in the reverse direction will result in deterioration of dehumidification performance.

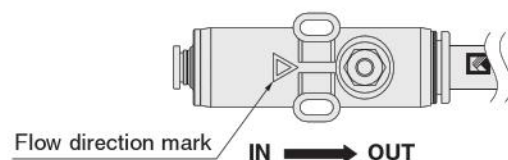

**8. Connecting and disconnecting tube**  
**Precautions for connecting a tube**

1. Check that the tube cut surface is perpendicular to the tube length, that there is no scratch on the outside of the tube, and that the tube shape has not become elliptical.
2. When connecting tubes, failure to push the tube in all the way to the tube end could result in leaks.

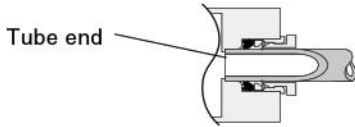

3. After connection, check that the tube cannot be pulled out.

**Precautions for disconnecting the tube**

1. When releasing a tube, always check that pressure inside the tube is at zero.
2. Push the release ring evenly all the way to the end, and then pull the tube straight out. An insufficient push could prevent the tube from being pulled out, or leave scratched or scarred tube fragments remaining behind inside the fitting.

**Tube connection and disconnection method**

**1. Connecting the tube**

The operator merely needs to push the tube all the way to the end of the tube dryer, after which a lock claw secures it in place, and an elastic sleeve seals the circumference around the tube.

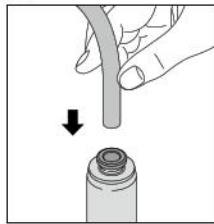

**2. Disconnecting the tube**

When removing the tube, push the release ring to open the lock claw, and then pull out the tube. Always shut off the air before removal.

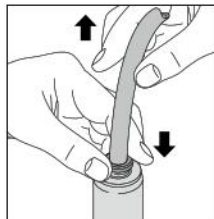

**Usable tubes**

Either a nylon tube or urethane tube can be used. For the tube outer diameter precision, use a nylon tube with nominal dimension of  $\pm 0.1 \text{ mm}$  [ $\pm 0.004 \text{ in.}$ ] or less, and a urethane tube with nominal dimension of  $\pm 0.15 \text{ mm}$  [ $\pm 0.0059 \text{ in.}$ ] or less, while the degree of ellipticity (difference between long diameter and short diameter) should be  $0.2 \text{ mm}$  [ $0.008 \text{ in.}$ ] or less.

- Cautions:**
1. Use a tube without scratches on the outer surface. If scratches appear due to repeated use, cut off that portion.
  2. Do not excessively bend or twist the tube near the fitting. It could be the cause of air leaks. If using a nylon tube, see the table below for the minimum bending radius.

Tube size	Minimum bending radius	
	Nylon tubes	Urethane tubes
$\phi 6$ [0.236]	30 [1.18]	15 [0.59]
$\phi 8$ [0.315]	50 [1.97]	20 [0.79]

A special tool is available for piping where the space is tight for easy removal.

**Special tool for tube removal**

- For  $\phi 3$ ,  $\phi 4$ , and  $\phi 6$  tubes  
Order Code: **UJ-1**
- $\phi 6$ ,  $\phi 8$ ,  $\phi 10$   $\phi 12$  tubes  
Order Code: **UJ-2**

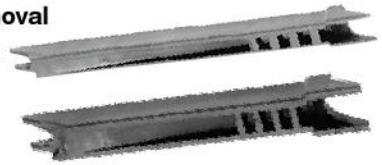

**Recommended circuits**

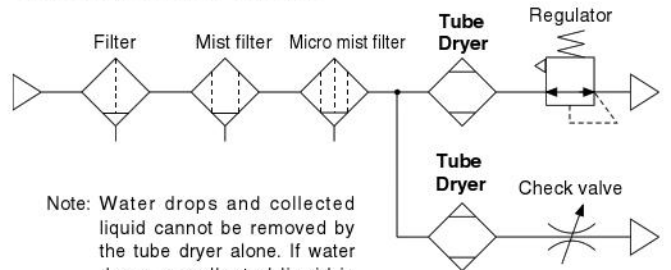

Note: Water drops and collected liquid cannot be removed by the tube dryer alone. If water drops or collected liquid is intruding, use a filter, mist filter, or micro-mist filter.

Note: Always mount a regulator or throttle valve, etc., on the secondary side of the tube dryer.



**Dew point indicator**

During the daily inspection, you can check the color of the dew point indicator to easily determine the degree of dryness in the compressed air inside the piping. When using the dew point indicator to check the degree of dryness in the compressed air, follow the procedure below.

**1. Initial color check**

When using compressed air in an actual work environment for the first time, perform an initial color check. About 30 minutes of compressed air flow is required before the dew point indicator color can be used to check the degree of dryness in the compressed air (when flowing at the rated volume). In addition, the initial color may vary depending on the pressure of the compressed air, and on the degree of dryness and flow rate, etc., of the supplied air.

**2. Color checks in daily inspections**

If the degree of dryness in the compressed air has declined, the color becomes redder than the initial color. You can check to see if the color has changed from the initial color to determine if the degree of dryness in the compressed air has changed. For the relationship between the dew point indicator color and the degree of dryness in the compressed air, see the color table provided with the product.

**3. Tube dryer replacement period**

The tube dryer separation membrane suffers a decline in function when in contact with oil or due to operation time, etc. If the daily inspection shows that the degree of dryness has declined sharply, check the operating conditions (pressure, flow rate, etc.). If there was no change in operating conditions yet the degree of dryness has deteriorated, it means that the time for replacement has been reached. Replace the tube dryer. Since the tube dryer cannot be disassembled, replace the entire product.

# Secondary Air Flow Rate, Secondary Air Dew Point, and Pressure Drop

## ● FDH-015

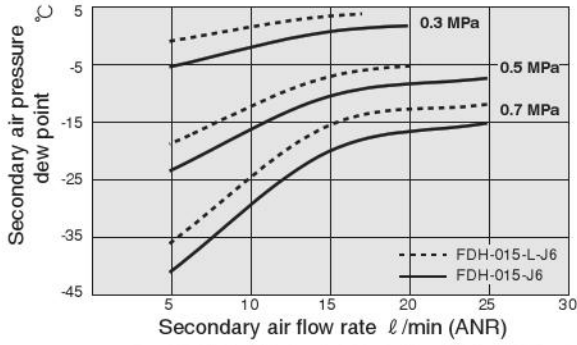

F = 9C/5 + 32, 1 ℓ/min = 0.0353 ft<sup>3</sup>/min., 1 MPa = 145 psi.

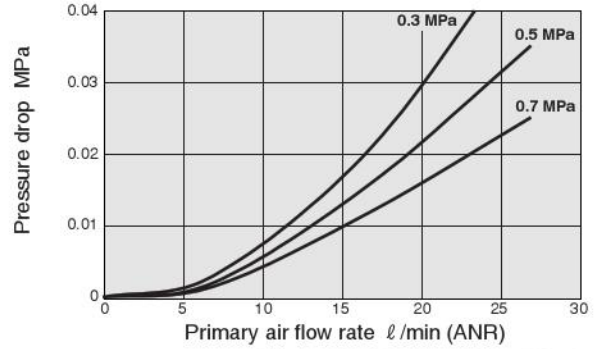

1 ℓ/min = 0.0353 ft<sup>3</sup>/min., 1 MPa = 145 psi.

## ● FDH-030

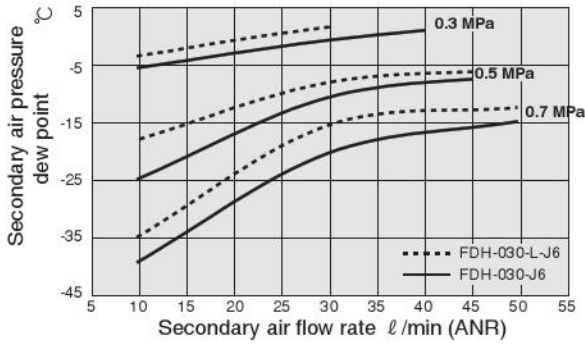

F = 9C/5 + 32, 1 ℓ/min = 0.0353 ft<sup>3</sup>/min., 1 MPa = 145 psi.

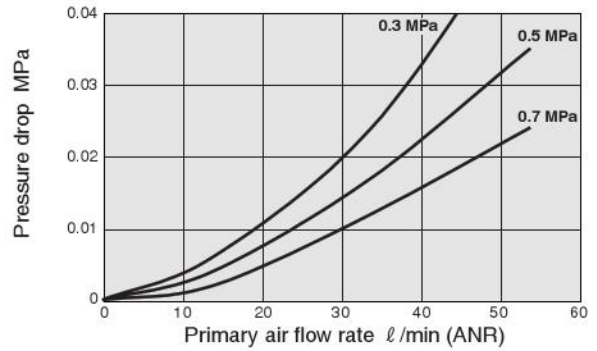

1 ℓ/min = 0.0353 ft<sup>3</sup>/min., 1 MPa = 145 psi.

Conditions: Supplied air temperature at 25°C [77°F], water vapor in supplied air saturated at 25°C [77°F], purged air piping port open.

## Relationship Between Operating Conditions and Secondary Air Dew Point

The air dryness increases with higher air pressure, lower temperature, and less flow rate for the supplied air.

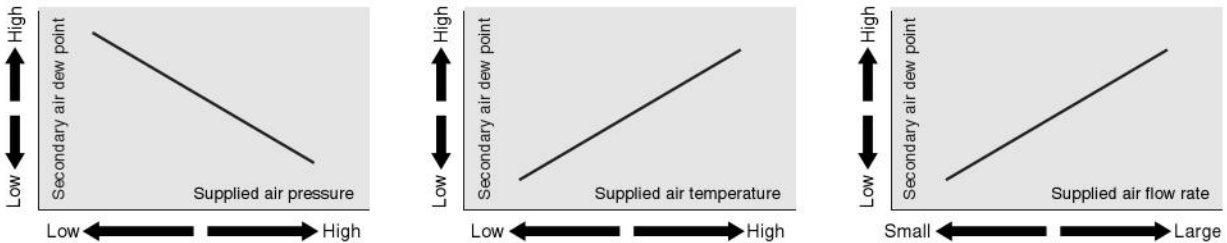

## Atmospheric Pressure Dew Point and Relative Humidity Conversion Table

Atmospheric pressure dew point °C [°F]	30 [86]	25 [77]	20 [68]	15 [59]	10 [50]	5 [41]	0 [32]	-5 [23]	-10 [14]	-15 [5]	-20 [-4]	-25 [-13]	-30 [-22]	-35 [-31]	-40 [-40]
Relative humidity															
Air temp. 10°C [50°F]	—	—	—	—	100	71	50	33	21	13	8.4	5.1	3.1	1.8	1.0
Air temp. 20°C [68°F]	—	—	100	73	52	37	26	17	11	7.1	4.4	2.7	1.6	1.0	0.55
Air temp. 30°C [86°F]	100	75	55	40	29	21	14	9.5	6.1	3.9	2.4	1.5	0.89	0.52	0.30

### Short Memo

#### Dew Point (Temperature)

When a gas containing water vapor is chilled at a constant pressure, the dew point is the temperature at which the water vapor can no longer exist in the gaseous state and begins to condensate. Since the maximum amount of water vapor (saturated water vapor volume) per unit of volume (1 m<sup>3</sup> [35.3 ft<sup>3</sup>]) is determined by the temperature, it is used as a value showing the amount of moisture in the gas.

This is why drops of water appear on the outside of a cup filled with chilled water.

When gas pressure is at normal atmospheric pressure, the dew point is called the atmospheric dew point, and when it is higher than atmospheric pressure, it is called the pressurized dew point.

#### Relative Humidity

Shows the degree of dampness in the gas, expressing the ratio of water vapor pressure to saturated water vapor pressure at a certain temperature. For calculation of moisture, etc., relative humidity can easily be used to show the ratio of the amount of water vapor to the amount of saturated water vapor at that temperature.

$$\text{Relative humidity} = \frac{\text{Water vapor pressure at a certain temperature}}{\text{Saturated water vapor pressure at the temperature}} \times 100 (\%)$$

$$= \frac{\text{Amount of water vapor at the temperature}}{\text{Amount of saturated water vapor at the temperature}} \times 100 (\%)$$

## How to select a model

### (1) Check the operating conditions.

Operating conditions (example 1)

- Secondary air flow rate: 25 ℓ/min [0.88 ft<sup>3</sup>/min.] (ANR)
- Primary air pressure: 0.7 MPa [102 psi.]
- Primary air saturation temperature: 20°C [68°F] saturation
- Secondary atmospheric dew point<sup>Note</sup>: -15°C [5°F]

Operating conditions (example 2)

- Secondary air flow rate: 10 ℓ/min [0.35 ft<sup>3</sup>/min.] (ANR)
- Primary air pressure: 0.5 MPa [73 psi.]
- Primary air saturation temperature: 20°C [68°F] saturation
- Secondary atmospheric dew point<sup>Note</sup>: -20°C [-4°F]

Note: For conversion from the pressurized dew point to atmospheric dew point, see the Dew Point Temperature Conversion Graph.

### (2) Use the correction coefficient to calculate the converted air flow rate from the selection formula below.

The converted air flow rate is the secondary air flow rate in the operating conditions converted to match the tube dryer rated conditions. Models with a rated secondary air flow rate larger than the converted air flow rate are the usable models. Since the dew point correction coefficient differs for the standard purge type and low purge type, calculate both types and compare.

#### Selection formula

$$\text{Rated secondary air flow rate} > \text{Converted air flow rate} = \frac{\text{Secondary air flow rate (}\ell/\text{min (ANR))}}{\text{Pressure correction coefficient} \times \text{Temperature correction coefficient} \times \text{Dew point correction coefficient}}$$

If more than one usable model is available, we recommend using the one with the smallest standard purge air flow rate.

#### Pressure correction coefficient

Primary air pressure MPa [psi.]	0.3 [44] or less	0.4 [58]	0.5 [73]	0.6 [87]	0.7 [102]
Correction coefficient	0.01	0.2	0.4	0.65	1

#### Temperature correction coefficient

Primary air saturation temperature °C [°F] saturation	5 [41]	10 [50]	15 [59]	20 [68]	25 [77]	30 [86]	35 [95]	40 [104]	45 [113]	50 [122]
Correction coefficient	2.3	1.9	1.6	1.3	1	0.8	0.6	0.45	0.3	0.2

#### Dew point correction coefficient

Secondary atmospheric dew point °C [°F]	-30 [-22]	-25 [-13]	-20 [-4]	-15 [5]	-10 [14]	-5 [23]	0 [32]
Standard purge type correction coefficient	0.5	0.7	1	1.4	1.8	2.5	3.3
Low purge type correction coefficient	0.4	0.5	0.7	1	1.4	1.9	2.6

(3) Selection examples

Selection example 1

Operating conditions (example 1)

- Secondary air flow rate: 25 l/min [0.88 ft<sup>3</sup>/min.] (ANR)
- Primary air pressure: 0.7 MPa [102 psi.]
- Primary air saturation temperature: 20°C [68°F] saturation
- Secondary atmospheric dew point: -15°C [5°F]



- Secondary air flow rate: 25 l/min [0.88 ft<sup>3</sup>/min.] (ANR)
- Correction coefficient (from coefficient table)
- Pressure correction coefficient: 1.0
- Temperature correction coefficient: 1.3
- Dew point correction coefficient: Standard purge type 1.4  
Low purge type 1.0

For standard purge type

$$\frac{25}{1.0 \times 1.3 \times 1.4} \doteq 13.7$$



**Converted air flow rate: From 13.7 l/min [0.484 ft<sup>3</sup>/min.] (ANR)**

**FDH-015-J6** (Standard purge air flow rate: 3 l/min [0.11 ft<sup>3</sup>/min.] (ANR))

**FDH-030-J6** (Standard purge air flow rate: 6 l/min [0.21 ft<sup>3</sup>/min.] (ANR))

For low purge type

$$\frac{25}{1.0 \times 1.3 \times 1.0} \doteq 19.2$$



**Converted air flow rate: From 19.2 l/min [0.678 ft<sup>3</sup>/min.] (ANR)**

**FDH-030-L-J6** (Standard purge air flow rate: 4 l/min [0.14 ft<sup>3</sup>/min.] (ANR))

In this condition, the three models **FDH-015-J6**, **FDH-030-J6**, and **FDH-030-L-J6** are usable. Of these three models, we recommend use of **FDH-015-J6**, which has the smallest standard purge air flow rate.

Selection example 2

Operating conditions (example 2)

- Secondary air flow rate: 10 l/min [0.35 ft<sup>3</sup>/min.] (ANR)
- Primary air pressure: 0.5 MPa [73 psi.]
- Primary air saturation temperature: 20°C [68°F] saturation
- Secondary atmospheric dew point: -20°C [-4°F]



- Secondary air flow rate: 10 l/min [0.35 ft<sup>3</sup>/min.] (ANR)
- Correction coefficient (from coefficient table)
- Pressure correction coefficient: 0.4
- Temperature correction coefficient: 1.3
- Dew point correction coefficient: Standard purge type 1.0  
Low purge type 0.7

For standard purge type

$$\frac{10}{0.4 \times 1.3 \times 1.0} \doteq 19.2$$



**Converted air flow rate: From 19.2 l/min [0.678 ft<sup>3</sup>/min.] (ANR)**

**FDH-030-J6** (Standard purge air flow rate: 6 l/min [0.21 ft<sup>3</sup>/min.] (ANR))

For low purge type

$$\frac{10}{0.4 \times 1.3 \times 0.7} \doteq 27.5$$



**Converted air flow rate: From 27.5 l/min [0.971 ft<sup>3</sup>/min.] (ANR)**

**FDH-030-L-J6** (Standard purge air flow rate: 4 l/min [0.14 ft<sup>3</sup>/min.] (ANR))

In this condition, the two models **FDH-030-J6** and **FDH-030-L-J6** are usable. Of these two models, we recommend use of **FDH-030-L-J6**, which has the smaller standard purge air flow rate.

### ● Dew Point Temperature Conversion Graph

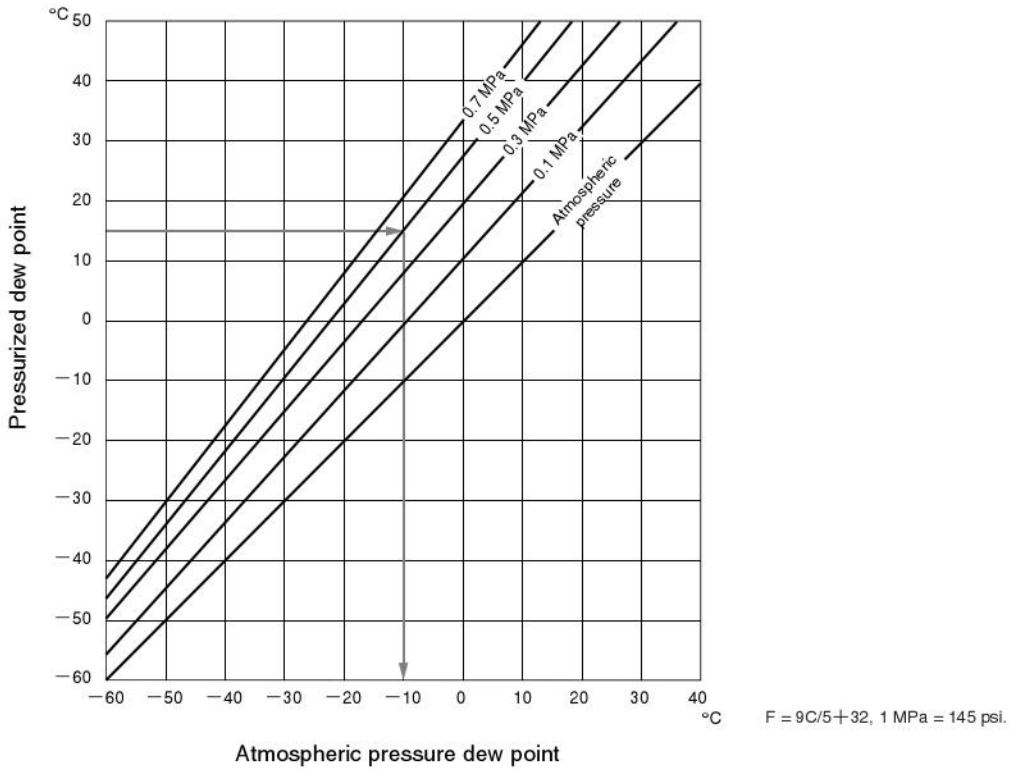

#### Example:

Find the atmospheric pressure dew point when the pressurized dew point is 15°C [59°F] and air pressure is 0.5 MPa [73 psi].

- 1) Follow the arrow from the pressurized dew point of 15°C [59°F] to find the intersection with the 0.5 MPa [73 psi.] pressure line.
- 2) Follow the arrow from the pressure line intersection to the intersection with the atmospheric pressure dew point.
- 3) The intersection with the atmospheric pressure dew point is the conversion value for the atmospheric dew point, -10°C [14°F].

## Specifications

Item	Models	FDH-015 (Standard purge type)	FDH-015-L (Low purge type)	FDH-030 (Standard purge type)	FDH-030-L (Low purge type)
Operating conditions	Media	Air			
	Operating pressure range MPa [psi.]	0.1 ~ 0.7 [15 ~ 102]			
	Supplied air temperature °C [°F]	5 ~ 50 [41 ~ 122]			
	Ambient temperature °C [°F]	5 ~ 50 [41 ~ 122], When stored 5 ~ 50 [41 ~ 122]			
	Ambient humidity RH%	0 ~ 70 (No condensation), When stored 0 ~ 70 (No condensation)			
Rating conditions	Piping connection fitting	φ 6, φ 8			
	Ambient temperature °C [°F]	25 [77]			
	Ambient humidity RH%	About 50			
	Supplied air temperature °C [°F]	25 [77]			
	Water vapor in supplied air	Saturation at 25°C [77°F]			
	Supplied air pressure MPa [psi.]	0.7 [102]			
	Atmospheric dew point °C [°F]	- 20 [ - 4]	- 15 [5]	- 20 [ - 4]	- 15 [5]
Rated primary air flow rate ℓ /min [ft. <sup>3</sup> /min.] (ANR)	18 [0.64]	17 [0.60]	36 [1.27]	34 [1.20]	
Rated secondary air flow rate ℓ /min [ft. <sup>3</sup> /min.] (ANR)	15 [0.53]		30 [1.06]		
Standard purge flow rate ℓ /min [ft. <sup>3</sup> /min.] (ANR)	3 [0.11]	2 [0.07]	6 [0.21]	4 [0.14]	
Materials	Body: Polybutylene terephthalate and urethane		Fitting seal portion: Fluoro rubber and coating		
Mass g [oz.]	92 [3.25]		116 [4.09]		

## Order Codes

**FDH** -  -  - **J6**

**Tube fitting specification**

**J6** : φ 6

**J8** : φ 8

**Purge type**

**Blank** : Standard purge

**L** : Low purge

**Dryer size**

**015** : Rated secondary air flow rate 15 ℓ /min [0.53 ft.<sup>3</sup>/min.] (ANR)

**030** : Rated secondary air flow rate 30 ℓ /min [1.06 ft.<sup>3</sup>/min.] (ANR)

Tube dryer

- Standard can be used as non-lubrication specification.

● FDH-015

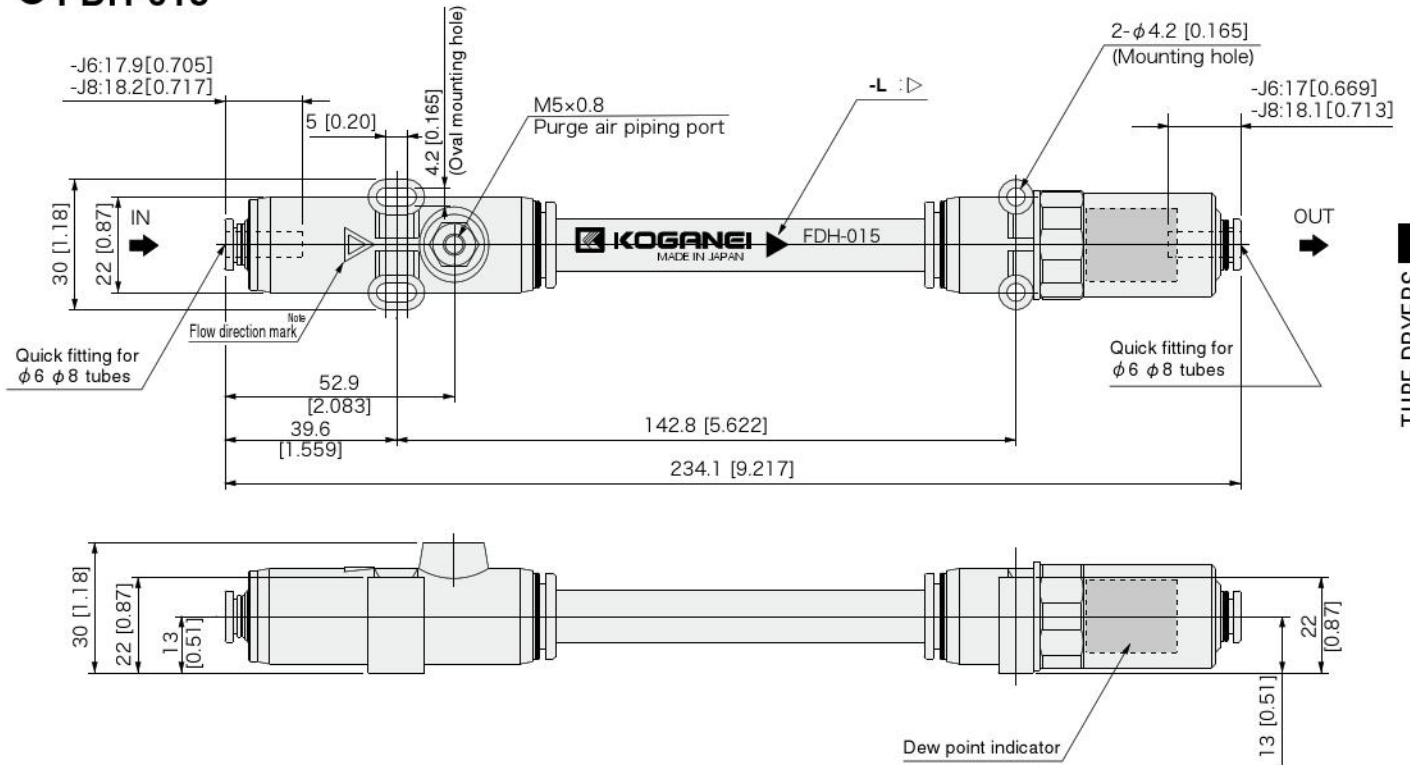

Note: Attach the piping so that the air flows in the direction shown by the flow direction mark.  
 Sending the flow in the reverse direction will result in deterioration of dehumidification performance.

TUBE DRYERS

● FDH-030

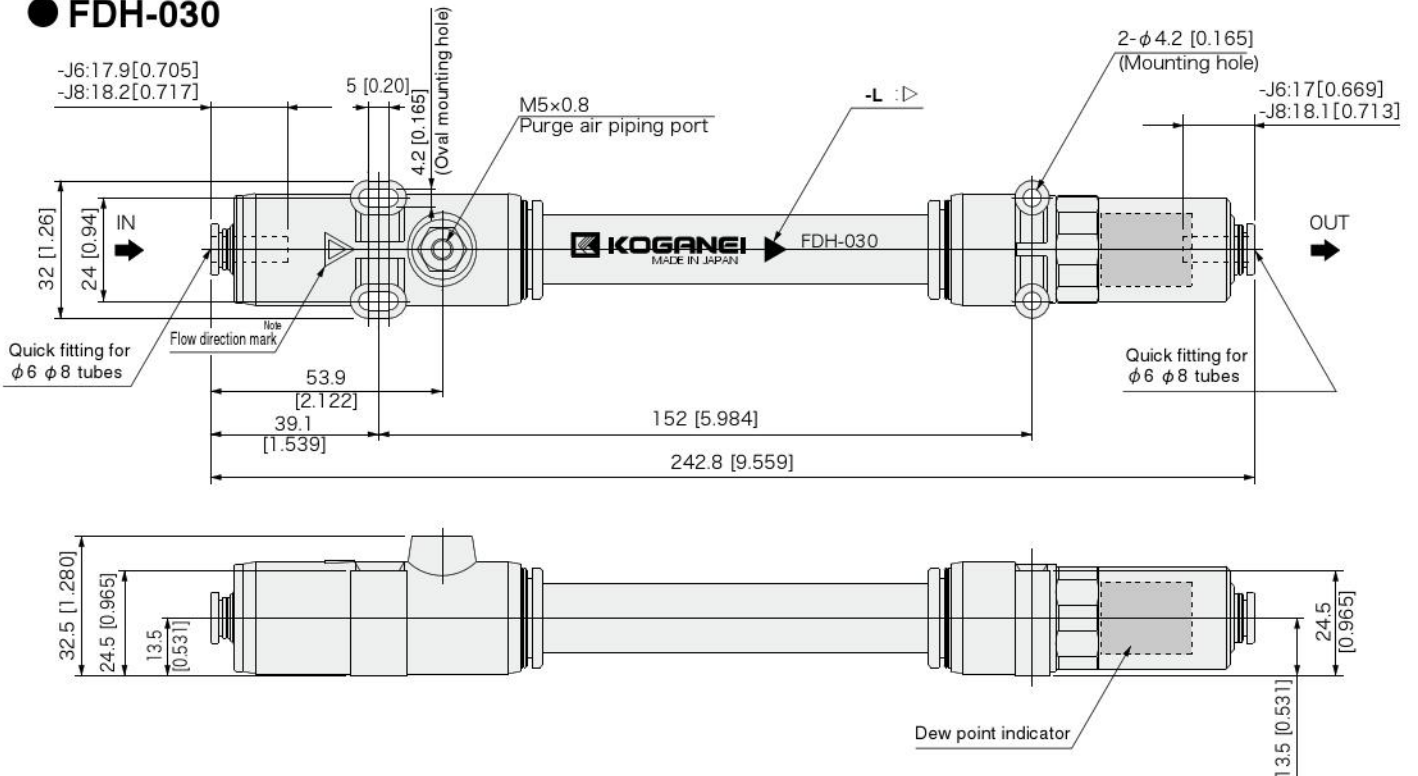

Note: Attach the piping so that the air flows in the direction shown by the flow direction mark.  
 Sending the flow in the reverse direction will result in deterioration of dehumidification performance.