

## Solenoid Valves F Series

Power consumption

**0.1W**  
(low-current type)



With reverse current  
protection circuit

*Low-current type and single/double dual use valves offer energy savings and a low price.*



**Redesigned**  
Solenoid Valves  
**F10 and F15**  
Series



Koganei Brand

All products **RoHS**-compliant

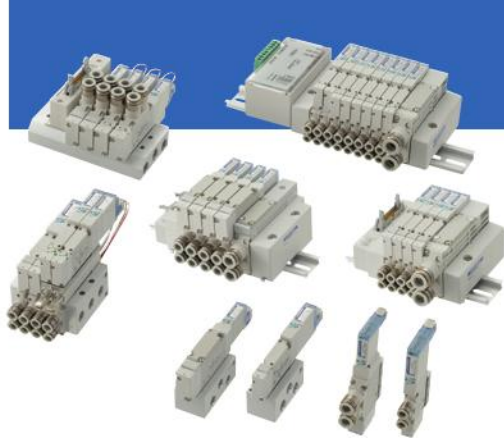

# SOLENOID VALVES F SERIES

## F10, F15, F18 SERIES

### Contents

Features	2	Operating Principles and Symbols	16
Product Range	5	Handling Instructions and Precautions	18
Energy-Saving Proposal Using the Solenoid Valve F10, F15 Series	8	Manifold Unit Adding Procedure	28
Notification of Changes to the Solenoid Valves F10 and F15 Series Specifications	9	Product Configurations for the F Series Serial Transmission Compatible Manifolds	37
Safety Precautions	13	Specifications of Serial Transmission Compatible Manifolds	38

Single Valve Unit	F10,15 SERIES 44	PC Board Manifold A Type (Base Piping Type)	54
	F18 SERIES 72	PC Board Manifold F Type (Direct Piping Type)	58
Monoblock Manifold A Type (Base Piping Type)	F10,15 SERIES 46	Split Manifold Non-plug-in Type	F10,15 SERIES 60
	F18 SERIES 74		F18 SERIES 78
Monoblock Manifold F Type (Direct Piping Type)	F10,15 SERIES 48	Split Manifold Plug-in Type	F10,15 SERIES 64
	F18 SERIES 76		F18 SERIES 82
Monoblock Manifold A Type, Wire-saving Type (Base Piping Type)	50	Serial Transmission Compatible Manifold	F10,15 SERIES 68
Monoblock Manifold F Type, Wire-saving Type (Direct Piping Type)	52		F18 SERIES 86



<b>SOLENOID VALVES F10 SERIES</b>	105
Specifications	106
Dimensions	111



<b>SOLENOID VALVES F15 SERIES</b>	137
Specifications	138
Dimensions	144



<b>SOLENOID VALVES F18 SERIES</b>	171
Specifications	172
Dimensions	177

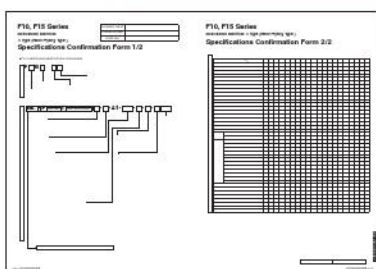

F Series Specifications Confirmation Form	199
---	-----

ORDER CODES

F10 SERIES

F15 SERIES

F18 SERIES

CONFIRMATION FORM

# Solenoid Valves F Series

Environmentally friendly **RoHS** Compliant product!

## The F Series is the Result of a Focus on Usability.

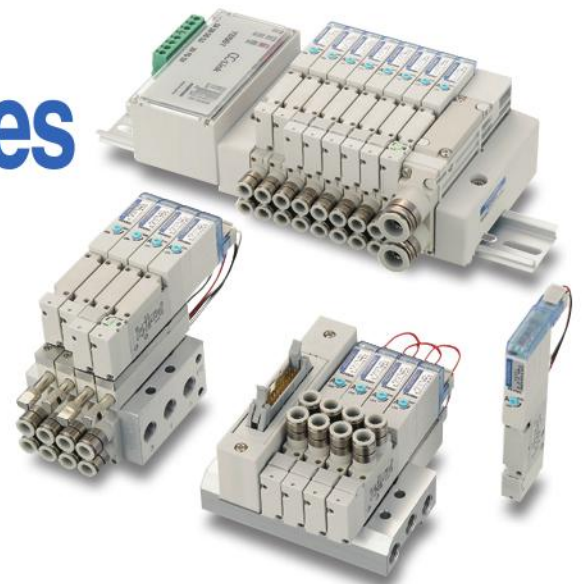

### 1 Single or double dual use valve

- With the F series 2-position valves, you can use a manual override to select either the single solenoid valve or the double solenoid valve function.

Note: A dedicated single solenoid valve is also available.



※2-position valve (Excluding T0 type)

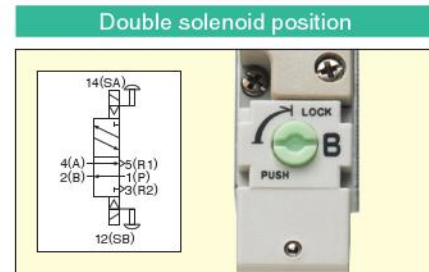
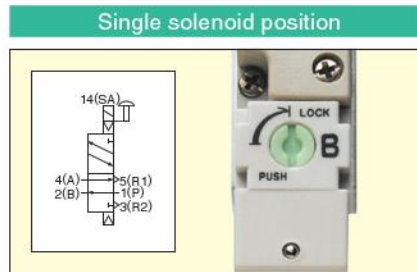

### 2 Employs dual use fittings

- Koganei's unique dual use fittings can be connected to two different types of tubes with differing outer diameters.
- No need to waste time selecting fittings based on the tube size.

Dual use fitting

※Mountable tube sizes:  
F10 series:  $\phi$  4 and  $\phi$  6  
F15 series:  $\phi$  6 and  $\phi$  8  
F18 series:  $\phi$  8 and  $\phi$  10

Note: A single use fitting can also be selected.

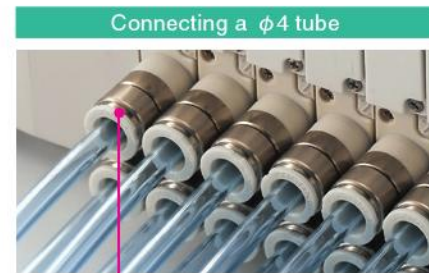

The same fitting as in the left photograph

### 3 Allows the fitting block to be changed for either base piping or direct piping

- Since the direction of the fitting blocks can be changed after purchase, the user is free to change the piping direction.

(Excluding monoblock manifold F type, and PC board manifold F type)

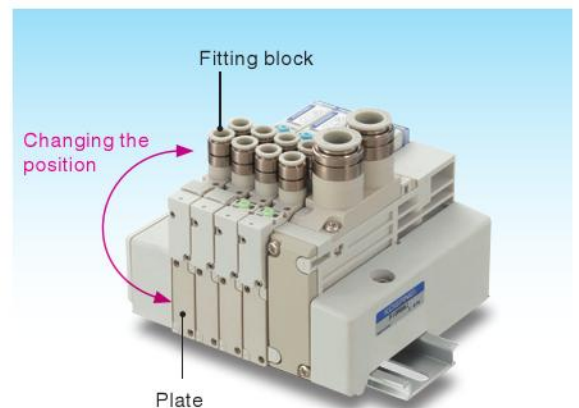

**Caution**

Before use, be sure to read the "Safety Precautions" on p.13.

# Redesigned Solenoid Valves F10 and F15 Series!

## Six characteristics make it even easier to use

### 1 More compact, lower power consumption

- The newly developed solenoid valve F10 and F15 series use less power.
- Total length reduced by 6 mm [0.236 in.].

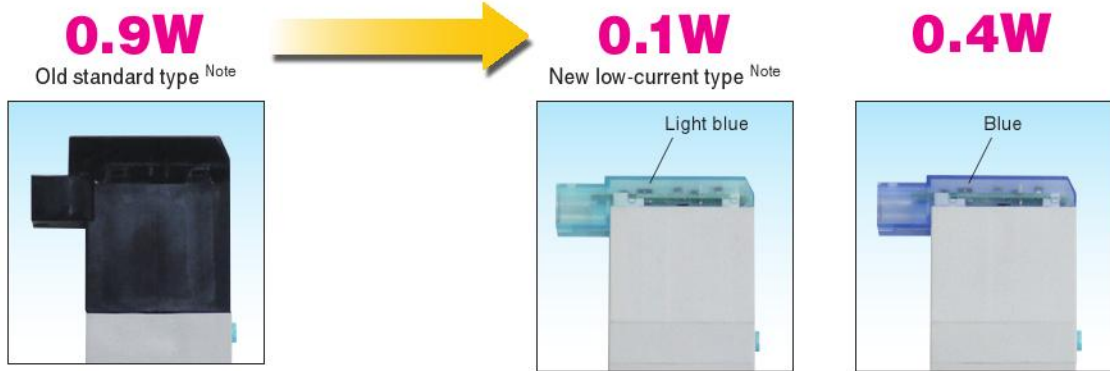

Note: With reverse current protection circuit

### 2 Tandem 3-port valve (4-position) has newly been added

- Two 3-port valve functions in one valve body.
- Using F series valves as an air-operated valve or for single-acting cylinder control saves space.
- Allows combined mounting with 5-port valve.

Model	4(A) side	2(B) side	Symbol
F10 <input type="checkbox"/> TA F15 <input type="checkbox"/> TA	Normally closed (NC)	Normally closed (NC)	
F10 <input type="checkbox"/> TB F15 <input type="checkbox"/> TB	Normally open (NO)	Normally open (NO)	
F10 <input type="checkbox"/> TC F15 <input type="checkbox"/> TC	Normally closed (NC)	Normally open (NO)	

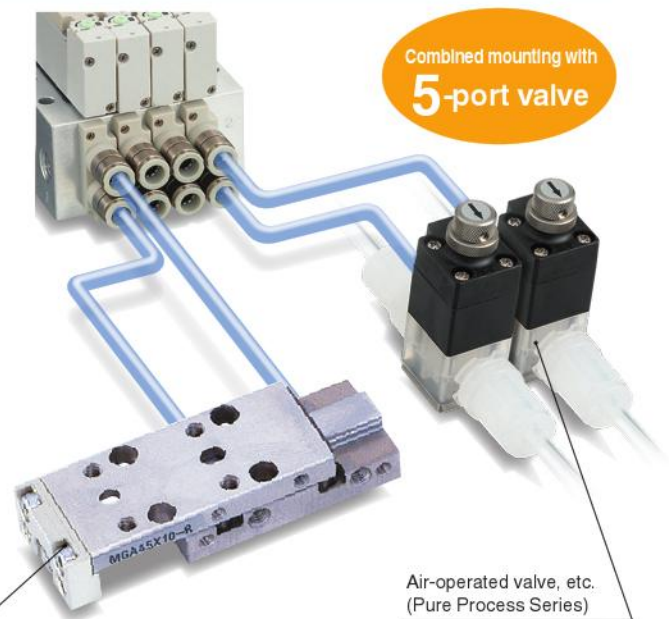

### 3 Wire-saving type has been added to monoblock manifold

- Wire-saving type added to monoblock manifold A and F types.
- Wiring specifications for flat cable connector and D-sub connector are available.

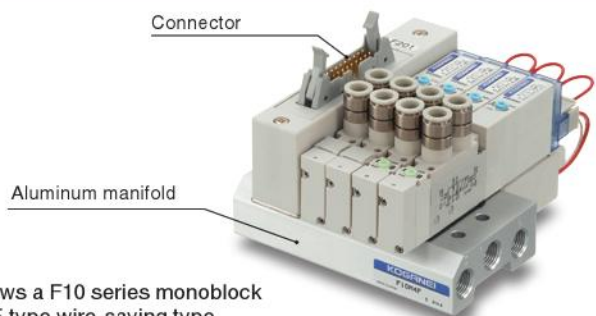

\*Photo shows a F10 series monoblock manifold F type wire-saving type.

## 4 Stop valve (optional) has been added (Only for Monoblock Manifold)

- Enables replacement of valves without stopping operation of various devices and instrumentation lines.
- Stop valve enables the opening and closing of each unit's flow path without shutting off the main air supply.

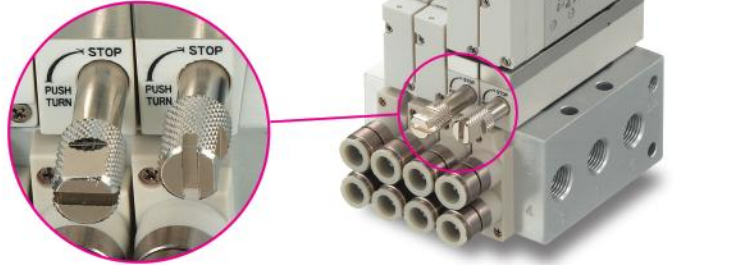

## 5 Back pressure prevention valve (optional) has been added

- Prevents back pressure problems caused when operating single acting cylinders, etc.

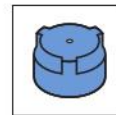
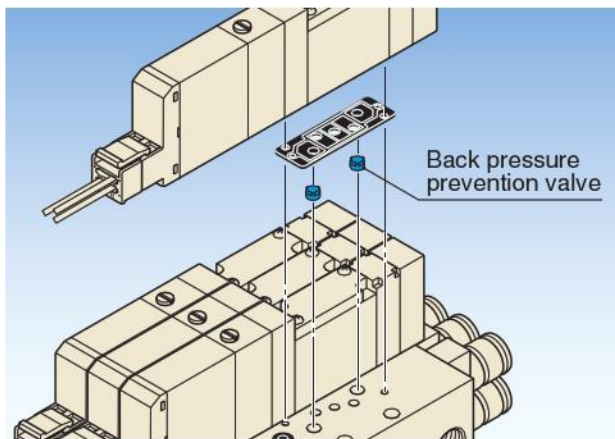

### Back pressure prevention valve

Two back pressure prevention valves are mounted on the manifold side. This prevents cylinder malfunctions caused by the exhaust air from other valves.

## 6 Slim and compact

### ■ Monoblock manifold F type

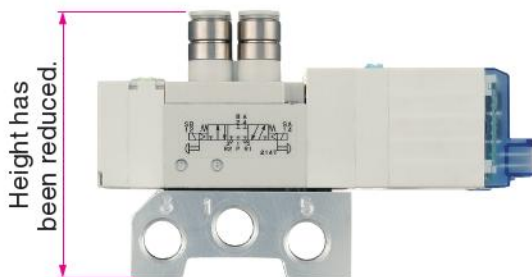

\*Photo shows F10 series.

### ■ Serial transmission type

- Transmission portion and manifold combined in a single-piece construction.

Compatible devices with serial transmission integrated manifold

- For OMRON CompoBus/S (16 outputs)
- For CC-Link (16 outputs)
- For CC-Link (32 outputs)
- For DeviceNet (16 outputs)
- For DeviceNet (32 outputs)
- For CompoNet (16 outputs)
- For EtherCAT (16 outputs)
- For EtherCAT (32 outputs)

- NEW** For EtherNet/IP (16 outputs)
- NEW** For EtherNet/IP (32 outputs)

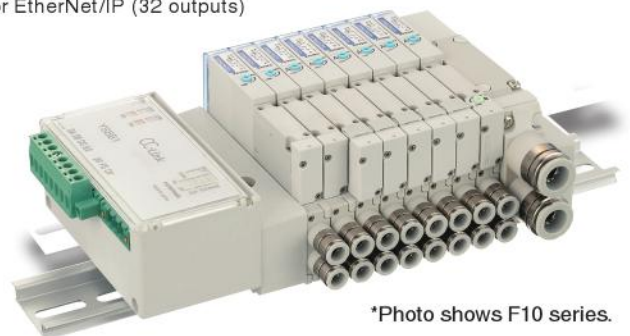

\*Photo shows F10 series.

# Product Range

## Solenoid Valves F10 Series



- Valve width: 10 mm [0.394 in.]
- Sonic conductance C: 0.97 dm<sup>3</sup>/(s·bar) [Cv: 0.27]
- Applicable cylinder bore sizes: φ20 [0.787 in.] ~ φ50 [1.969 in.]

## Solenoid Valves F15 Series



- Valve width: 15 mm [0.591 in.]
- Sonic conductance C: 2.05 dm<sup>3</sup>/(s·bar) [Cv: 0.57]
- Applicable cylinder bore sizes: φ40 [1.575 in.] ~ φ80 [3.150 in.]

## Solenoid Valves F18 Series



- Valve width: 18 mm [0.709 in.]
- Sonic conductance C: 3.6 dm<sup>3</sup>/(s·bar) [Cv: 1]
- Applicable cylinder bore sizes: φ50 [1.969 in.] ~ φ100 [3.937 in.]

## Single Valve Unit

Valves can be used as single units by attaching inlet port blocks. Mounting brackets are also available.

### Outlet port specifications

Series	With sub-base		For single valve unit or manifold use									
	Female thread		With female thread block			With dual use fitting block			With single use fitting block			
	Rc1/8 NPT1/8	Rc1/4 NPT1/4	M5 10-32 UNF	Rc1/8 NPT1/8	Rc1/4 NPT1/4	φ4 & φ6	φ6 & φ8	φ8 & φ10	φ4	φ6	φ8	φ10
F10	●		●			●			●	●		
F15	●			●			●			●	●	
F18		●			●			●			●	●



- F10,F15 Order codes p.44,45
- F18 Order codes p.72,73
- F10 Dimensions p.111
- F15 Dimensions p.144
- F18 Dimensions p.177

## Monoblock Manifold A Type (Base Piping Type)

This base piping type manifold offers easy maintenance and cost performance. Replacing the outlet block enables its use as a direct piping type manifold. Using a pre-wired common terminal plug connector greatly reduces wiring work.

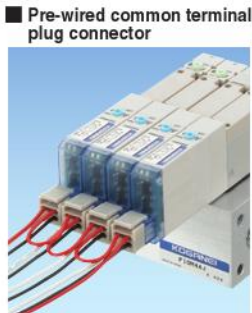

- F10,F15 Order codes p.46,47
- F18 Order codes p.74,75
- F10 Dimensions p.114
- F15 Dimensions p.147
- F18 Dimensions p.180

## Monoblock Manifold F Type (Direct Piping Type)

The direct piping type manifold offers excellent cost performance. Using a pre-wired common terminal plug connector greatly reduces wiring work.



- F10,F15 Order codes p.48,49
- F18 Order codes p.76,77
- F10 Dimensions p.116
- F15 Dimensions p.149
- F18 Dimensions p.182

**NEW**

## Monoblock Manifold A Type, Wire-Saving Type (Base Piping Type)

Wire-saving type of monoblock manifold A type. Wiring specifications include the flat cable connector mounting type and the D-sub connector mounting type.

Note: Not available in the F18 series.

With fitting block



With female thread block



Order codes p.50,51

F10 Dimensions p.117

F15 Dimensions p.150

**NEW**

## Monoblock Manifold F Type, Wire-Saving Type (Direct Piping Type)

Wire-saving type of monoblock manifold F type. Wiring specifications include the flat cable connector mounting type and the D-sub connector mounting type.

Note: Not available in the F18 series.

With fitting block



With female thread block



Order codes p.52,53

F10 Dimensions p.118

F15 Dimensions p.151

## PC Board Manifold

A MIL type 20-pin flat cable connector is installed on the monoblock manifold to achieve both wiring savings and cost performance. Combined use of the Koganei PC wiring system and wiring specification -F201 allows for more effective wiring savings.

Note: Not available in the F18 series.

A type (Base piping type)



F type (Direct piping type)



Order codes p.54-59

F10 Dimensions p.119

F15 Dimensions p.152

## Split Manifold Non-Plug-in Type

Enables easy addition or removal of manifold blocks. This system offers more flexibility in conforming to changes in specifications.

Manifold port with fitting block



Valve port with fitting block



Manifold port with female thread block



Valve port with female thread block



F10,F15 Order codes p.60-63

F18 Order codes p.78-80

F10 Dimensions p.120

F15 Dimensions p.153

F18 Dimensions p.183

# Split Manifold Plug-in Type

Manifold conforms to reducing wiring work. Adding on wiring allows adding manifold units.  
 Combined use of the Koganei PC wiring system and wiring specification -F201 offers more effective wiring savings.

- F10,F15**  
Order codes p.64-67
- F18**  
Order codes p.82-85
- F10**  
Dimensions p.122
- F15**  
Dimensions p.155
- F18**  
Dimensions p.185



## Wiring Specifications



Flat cable connector top surface (vertical) wiring type <sup>Note</sup>



Flat cable connector side surface (horizontal) wiring type <sup>Note</sup>



D-sub connector top surface (vertical) wiring type <sup>Note</sup>



D-sub connector side surface (horizontal) wiring type <sup>Note</sup>



Terminal block

Note: You can change the connector direction.



For the flat cable connector and D-sub connector, the no power supply terminal type is also available.

**Caution:** For the F18 series, neither the connector side surface (horizontal) wiring type nor the no power supply terminal type is available.

Photograph shows flat cable connector.

Remark: You can also select the wiring position (wiring block) for right-side mounting.

## Serial Transmission Compatible Manifold



Integrated type (F10, F15 series)



Stand-alone type

- For CC-Link
- For OMRON B7A Link Terminal
- For OMRON CompoBus/S
- For CompoNet
- For DeviceNet <sup>Note</sup>
- For EtherCAT <sup>Note</sup>
- For EtherNet/IP <sup>Note</sup>

Note: Not available in the F18 series.

※For details, see p. 37-40.

- F10,F15**  
Order codes p.68-71
- F18**  
Order codes p.86-88
- F10**  
Dimensions p.131
- F15**  
Dimensions p.164
- F18**  
Dimensions p.194



For EtherCAT (F10,F15 series)  
 For EtherNet/IP (F10,F15 series) **NEW**

Remark: You can also select the wiring position (transmission block) for right-side mounting.

# Energy-Saving Proposal Using the Solenoid Valves F10 and F15 Series

## Comparison of power consumption (Reference)

With the cylinder conditions operating 5 seconds in the extended side and 5 seconds in the retraced side, and an operating time of 12 hours per day, five days per week, and 50 weeks per year, the power consumption for one year is calculated. (Annual power consumption: Power consumption per hour×12 hours×5 days×50 weeks)

### ■ Case 1: when single solenoid is used (0.4W: Standard type)



### ■ Case 2: when single solenoid is used (0.1W: Low current type)



### ■ Case 3: when double solenoid is used (0.4W: Standard type)

<Pulse control using self-holding function>



### ● Results for calculation of power consumption under the above conditions, and power consumption graph

Solenoid	Power consumption (W)	Energizing time (s)		Number of operations per hour (cycles)	Electric energy per hour (Wh)	Annual electric energy (kWh) and annual electric energy cost
		SA : ON	SB : ON			
Single solenoid (standard type)	0.4	5	–	360	0.200	0.6 [13.2 yen]
Single solenoid (low-current type)	Starting: 0.4/holding: 0.1	5	–	360	0.052	0.156 [3.43 yen]
Double solenoid (standard type)	0.4	0.05	0.05	360	0.004	0.012 [0.264 yen]

Remark: Comparison using new type solenoid 24VDC specification. Electricity charges are assumed to be 22 yen/kWh.

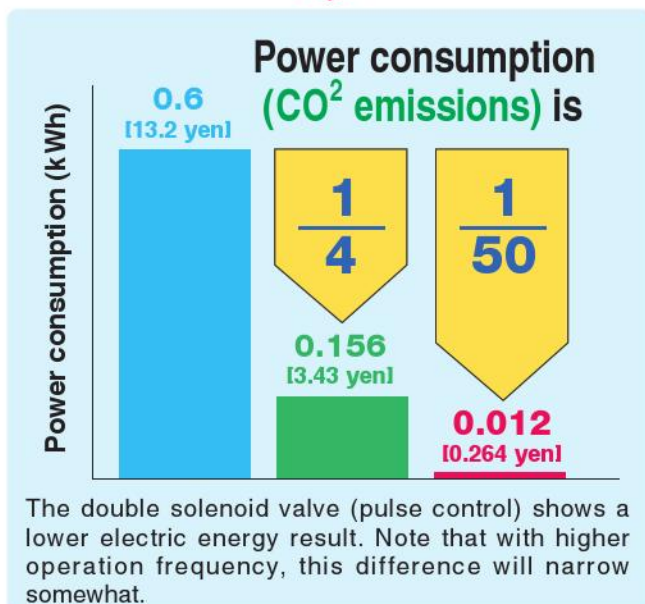

- With use of 0.1W low-current type, the power consumption is reduced to 1/4.

**Furthermore,**

- If pulse control is performed using a double solenoid, power consumption can be sharply reduced.
- Solenoid valves F series is **single/double dual use valves**.
- Since the single solenoid and double solenoid are **the same price**<sup>Note</sup>, it also enables cost benefits.

Note: For 2-position valve. Excluding T0 type.

# Notification of Changes to the Solenoid Valves F10 and F15 Series Specifications

Thank you for using our products.

Now we have undertaken to introduce some changes to the specifications of the popular Solenoid Valves F10 and F15 Series (no specification changes have been made to the Solenoid Valves F18 Series).

With these new solenoids, we have reduced both the wattage and total length of the valve. In addition, we have made the F type and serial transmission manifolds more compact.

We hope for your understanding of these changes and for your continued use in the future.

## ■ Descriptions of changes

### ● Single valve unit

- Large reduction in power consumption and 6 mm [0.236 in.] shorter in total length while maintaining 100% mounting and wiring interchangeability with the old model.

Unit: mm [in.]

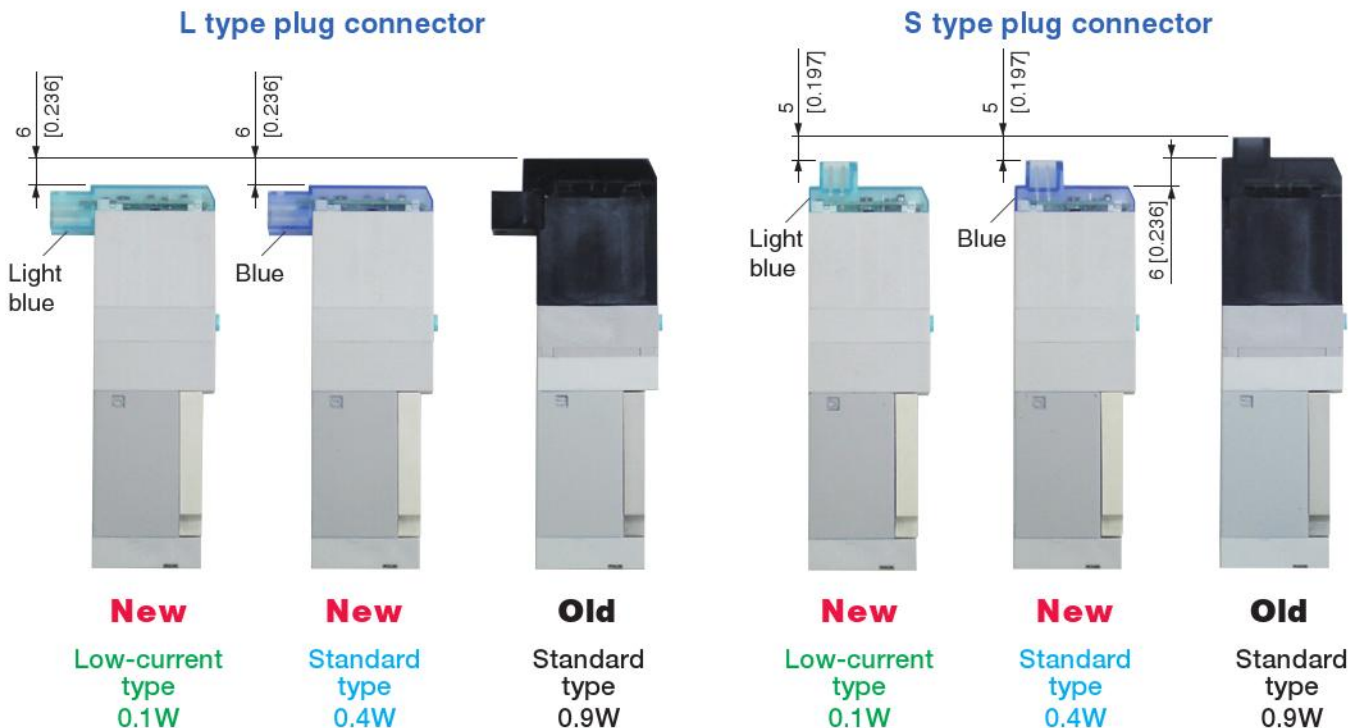

\*Photo shows F10 series. (F15 series is similar.)

- High-speed circuit employed on coil circuit board to achieve faster OFF response.
- Newly designed A and B independent coils allow for optional tandem 3-port valve.

# Notification of Changes to the Solenoid Valves F10 and F15 Series Specifications

## ● Monoblock manifold

- More compact F type manifold that eliminates PR port (collected in 5 (R1) port).

### ■ F10 Series (reference) mm [in.]

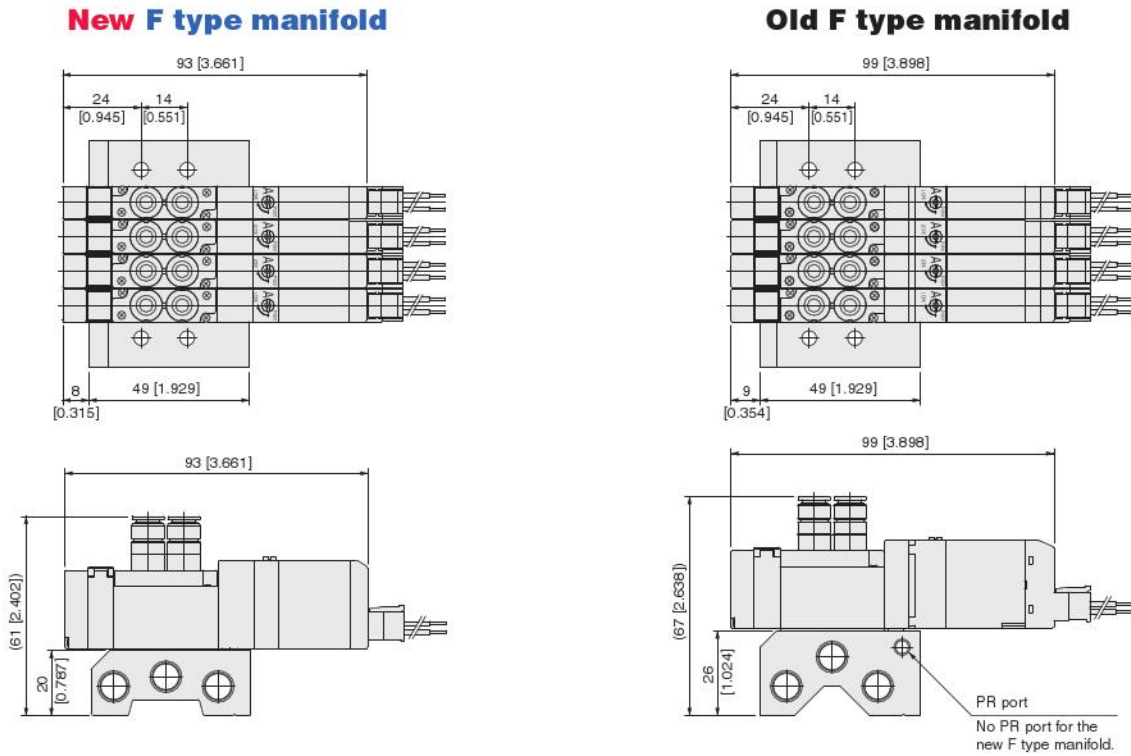

### ■ F15 Series (reference) mm [in.]

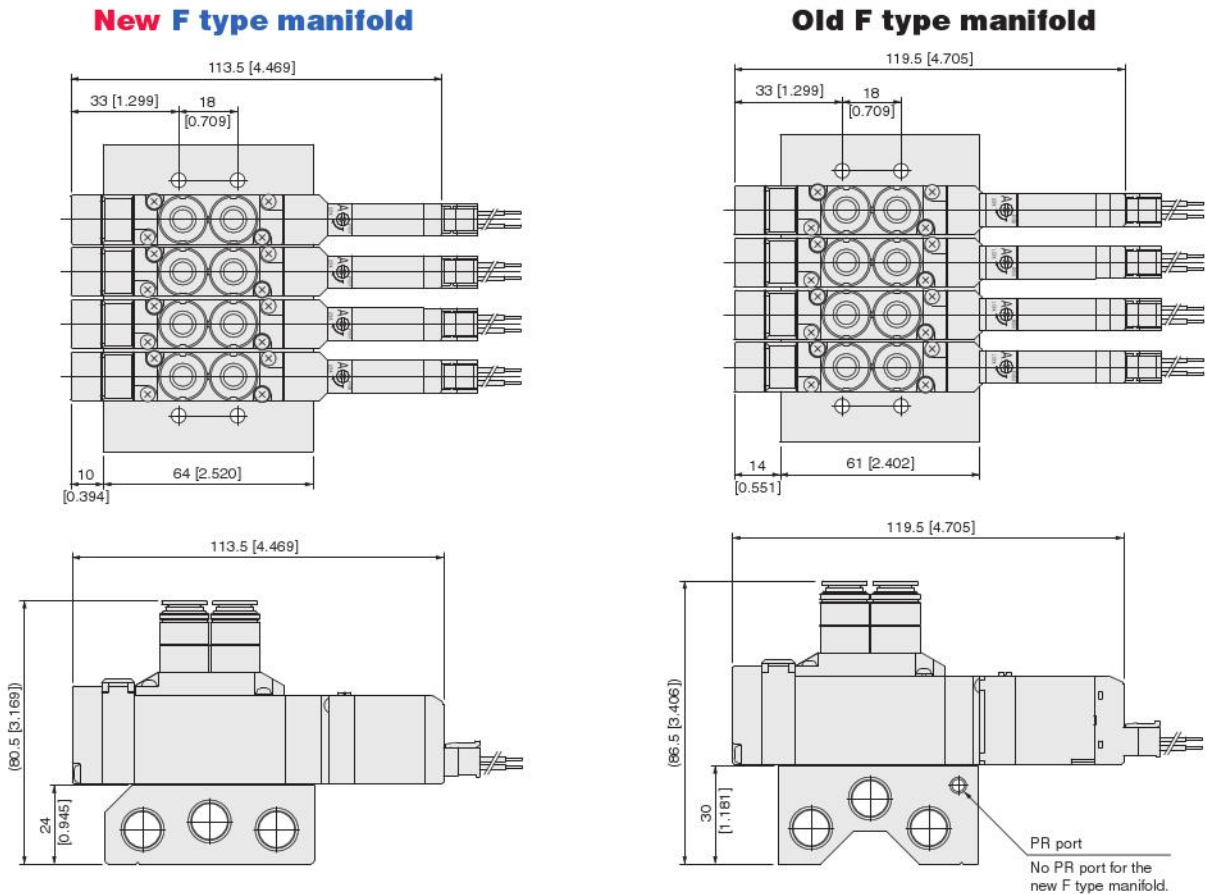

- Optional back pressure prevention valve for both the A type and F type manifolds now available.
- Optional sandwich-type stop valve now available.

## ● Split type manifold/serial transmission compatible manifold

- Coil portion flattened by minimizing the valve size.
- Enables selection and switching between top surface wiring and side surface wiring with flat cable connector and D-sub connector installation.
- Optional no power supply terminal type (standard type comes with power supply terminal) now available.
- More compact serial transmission device and manifold combined in single-piece construction (some models connected with flat cable).
- Optional back pressure prevention valve now available.
- Changed color of a valve base assembly cover from light blue to ivory in order to enable identification between the old type and new type.  
(For differentiation between new and old type, see p.12.)

### ■ F10 Series split manifold plug-in type (reference) mm [in.]

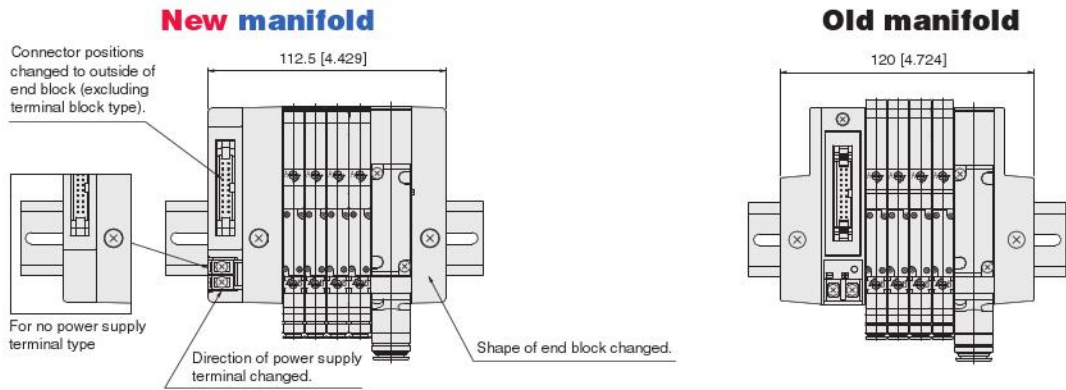

### ■ F15 Series split manifold plug-in type (reference) mm [in.]

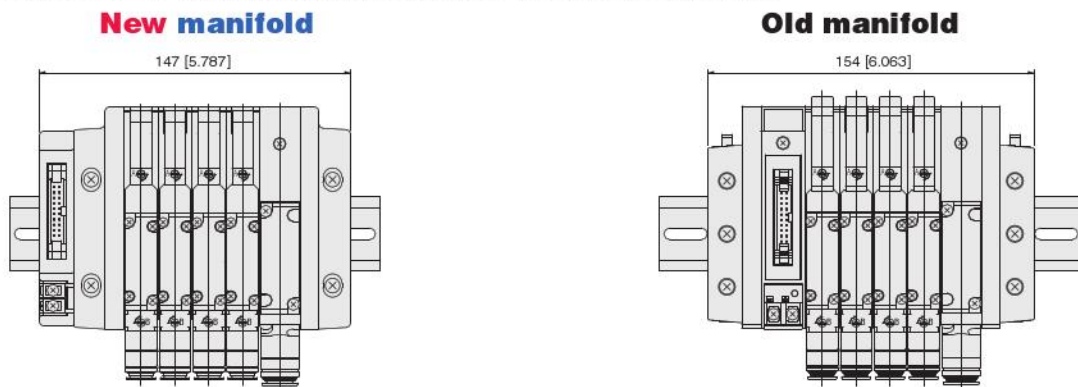

### ■ F10 Series serial transmission compatible manifold (reference) mm [in.]

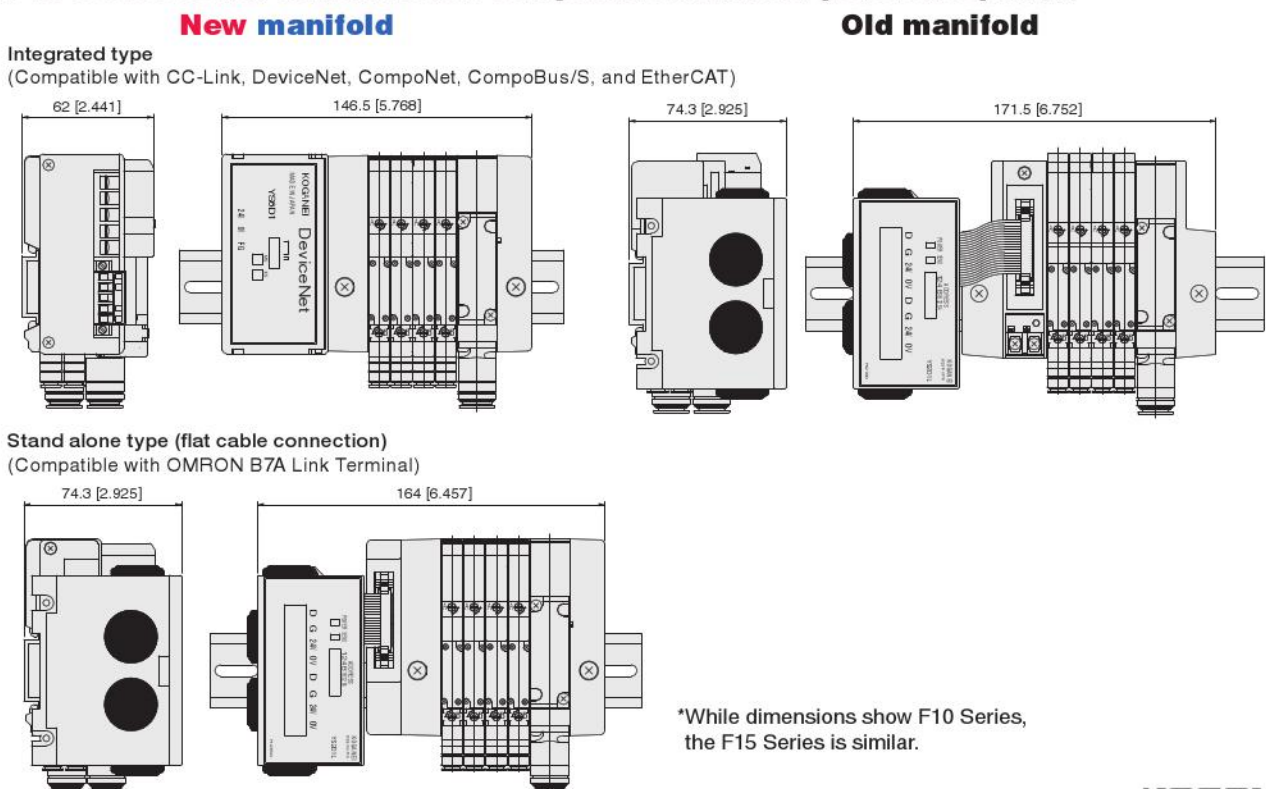

\*While dimensions show F10 Series, the F15 Series is similar.

# Notification of Changes to the Solenoid Valves F10 and F15 Series Specifications

■ Reference photo: Valve base assembly (Photo shows F10 Series.)

**New manifold**

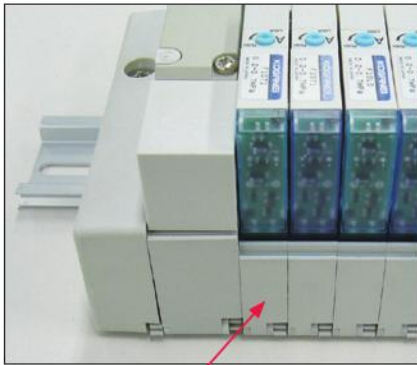

Color of cover: Ivory

**Old manifold**

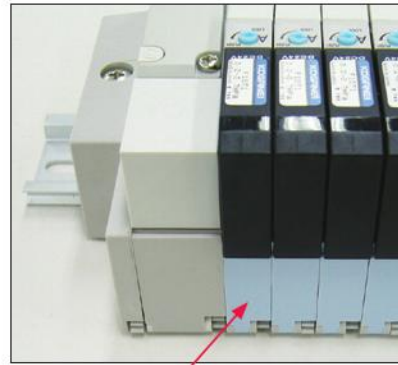

Color of cover: Light blue

## ● Others

### 1. Changes in the monoblock manifold (aluminum manifold) gasket

Along with the back pressure prevention valve becoming an option, the gasket configuration has also been changed. Note that a new gasket type cannot be fitted onto and used on an old type manifold. When replacing a mounted valve, order an old type gasket if you need to replace the gasket of an old type manifold. (Old type gasket model for the F10 Series: **Q-F10Z-GS1**, old type gasket model for the F15 Series: **Q-F15Z-GS1**)

**For new type manifold**

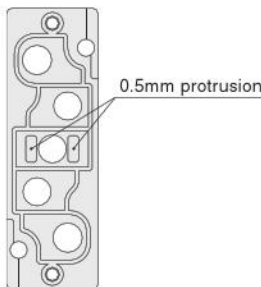

**For old type manifold**

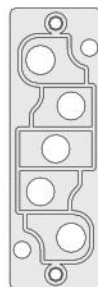

Mounted valve	New/old type gasket	New type manifold	Old type manifold
New type valve	New type gasket	○	×
	Old type gasket	×	○
Old type valve	New type gasket	○	×
	Old type gasket	×	○

Note: There is no gasket replacement for a split manifold or serial transmission compatible manifold.

### 2. Determining whether a monoblock manifold A type or F type, or PC board manifold A type or F type is an old type or new type

**New type manifold**

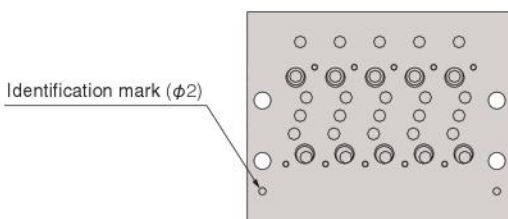

**Old type manifold**

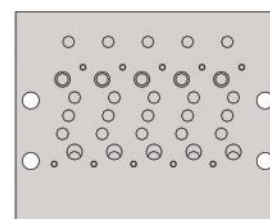

### 3. Connectors

**New type connector (gray)**







**Old type connector (black)**



There have been no changes in shapes.

Before selecting and using the products, please read all the "Safety Precautions" carefully to ensure proper product use. The Safety Precautions described below are to help you use the product safely and correctly, and to prevent injury or damage to you, other people, and assets. Be sure to observe these safety precautions together with the following safety regulations of ISO4414 (Pneumatic fluid power - General rules and safety requirements for systems and their components), and JIS B 8370 (General rules relating to systems).

The directions are ranked according to degree of potential danger or damage: "DANGER", "WARNING", "CAUTION" and "ATTENTION."

 <b>DANGER</b>	Indicates situations that can be clearly predicted as dangerous. Death or serious injury may result if the situation is not avoided. It could also result in damage or destruction of assets.
 <b>WARNING</b>	Indicates situations that, while not immediately dangerous, could become dangerous. Death or serious injury may result if the situation is not avoided. It could also result in damage or destruction of assets.
 <b>CAUTION</b>	Indicates situations that, while not immediately dangerous, could become dangerous. Failure to avoid the situation creates the risk of minor or semi-serious injury. It could also result in damage or destruction of assets.
 <b>ATTENTION</b>	While there is little chance of injury, this content refers to points that should be observed for appropriate use of the product.

- **This product was designed and manufactured for use in general industrial machinery.**
- When selecting and handling equipment, the system designer or another person with sufficient knowledge and experience should always read the "Safety Precautions", "catalog", "instruction manual", and other literature before commencing operation. Improper handling is dangerous.
- After reading the instruction manual, catalog, and other documentation, always place them in a location that allows easy availability for reference to users of this product.
- Whenever transferring or lending the product to another person, always attach the catalog, instruction manual, and other information to the product where they are easily visible in order to ensure that the new user can use the product safely and properly.
- The danger, warning and caution items listed under these "Safety Precautions" do not cover all possible contingencies. Read the catalog and instruction manual carefully, and always keep safety first.

 **DANGER**

- Do not use for the purposes listed below:
  1. Medical equipment related to maintenance or management of human lives or bodies.
  2. Mechanical devices or equipment designed for the purpose of moving or transporting people.
  3. Critical safety components in mechanical devices.
 This product has not been planned or designed for purposes that require advanced stages of safety. It could cause injury to human life.
- Do not use in locations with or near dangerous substances such as flammable or ignitable substances. This product is not explosion-proof. It could ignite or burst into flames.
- When attaching the product, always firmly support and secure them (including workpieces) in place. Dropping or falling of the product or improper operation could result in injury.
- Persons who use a pacemaker, etc., should keep a distance of at least 1 meter [3.28 ft.] away from the product. There is a possibility that the pacemaker will malfunction due to the strong magnet built into the product.
- Never attempt to modify the product. It could result in abnormal operation leading to injury, etc.
- Never attempt inappropriate disassembly, assembly or repair of the product's basic construction, or of its performance or functions. This could result in injury, electric shock, fire, etc.
- Do not splash water on the product. Spraying it with water, washing it, or using it underwater could result in malfunction of the product leading to injury, electric shock, fire, etc.
- While the product is in operation, avoid touching it with your hands or otherwise approaching too close. In addition, do not make any adjustments to the interior or to the attached mechanisms (manual override, connecting and disconnecting of wiring connectors, adjustment of pressure switches, or release or connection of piping tubes or plugs) while in operation. The actuator can move suddenly, possibly resulting in injury.

 **WARNING**

- Do not use the product in excess of its specification range. Such use could result in product breakdowns, function stop, damage or drastically reduce the operating life.
- Before supplying air or electricity to the device and before starting operation, always conduct a safety check of the area of machine operation. Unintentional supply of air or electricity could possibly result in electric shock, or in injury caused by contact with moving parts.

- Do not touch the terminal and the miscellaneous switches, etc., while the device is powered on. There is a possibility of electric shock and abnormal operation.
- Do not throw the product into fire. The product could explode and/or release toxic gases.
- Do not sit on the product, place your foot on it, or place other objects on it. Accidents such as falling or tripping over the product could result in injury. Dropping the product could result in injury, or also damage or break it resulting in abnormal or erratic operation, or runaway, etc.
- When conducting any kind of operation for the product, such as maintenance, inspection, repair, or connection/disconnection or replacement of piping, always turn off the air supply completely and confirm that residual pressure inside the product or in piping connected to the product is zero before proceeding. In particular, be aware that residual air will still be in the air compressor, vacuum pump or air storage tank. The actuator could abruptly move if residual air pressure remains inside the piping, causing injury.
- Before commencing normal operation, always release the lock of the locking type manual override, and confirm that the manual override is in the normal position and that the main valve is in the proper switching position, and only then commence the operation. Failure to do so could lead to erroneous operation.
- Always shut OFF the power before wiring operations. Wiring with the power ON could result in electric shock.
- Always apply the specified voltage to the solenoid. Applying the wrong voltage could result in failure to perform the intended function, and could damage or burn the product itself.
- Avoid scratching the cords of lead wires, etc. Letting the cords be subject to scratching, excessive bending, pulling, rolling up, or being placed under heavy objects or squeezed between two objects, may result in current leaks or defective continuity that lead to fire, electric shock, or abnormal operation.
- Do not pull out the connectors while the power is ON. Also, do not apply unnecessary stress on the connector. It could result in erratic equipment operation that could lead to personal injury, equipment breakdown, or electrical shock, etc.
- Always check the Catalog to ensure that the product wiring and piping is done correctly. Errors in wiring and piping could lead to abnormal operation of the actuators, etc.
- In the first operation after the equipment has been idle for 48 hours or more, or has been in storage, there is a possibility that contacting parts have got stuck, resulting in equipment operation delays or sudden movements. For these first operations, always run a test operation before use to check that operating performance is normal.

- In low frequency use (more than 30 days between uses), there is a possibility that contacting parts may have stuck together, resulting in equipment operation delays or sudden movements that could lead to personal injury. Run a test operation at least once every 30 days to confirm that movement is normal.
- For double solenoid type (excluding the Tandem 3-port valve), do not apply current through both solenoids simultaneously. It is impossible in such a situation to maintain the correct valve position, and the equipment may operate in an unintended direction, leading to the possibility of equipment breakdown or personal injury.
- Do not use the solenoid valves or the wiring that controls them, near power lines where large electrical currents are flowing, or in locations subject to high magnetic fields or power surges. Such application could lead to unintended operation.
- The solenoid valve can generate surge voltage and electromagnetic waves when the switch is turned OFF, affecting the operations of surrounding equipment. Use solenoids with surge suppression, or take countermeasures in the electrical circuits for surges or electromagnetic waves.
- Do not use the product where ozone may be generated, such as near ocean beaches or other places subject to direct sunlight or mercury lamps. Ozone can cause rubber parts to deteriorate, which can lead to degraded performance and functions, or to equipment stoppages. (Excludes items where measures against ozone have been taken.)
- Do not use any media other than shown on the specifications. Use of non-specified media could lead to functional shutdown after a short period, to sudden performance drops, or to shorter operating life.
- If mounting the solenoid valve inside a control panel, or if energizing it for long periods, provide heat radiation measures to ensure that temperatures surrounding the solenoid valve always remain within the specified temperature range. In addition, if energizing continuously over long periods, rising temperatures due to generation of heat in the coil can lead to a decline in solenoid valve performance and operating life, and have adverse effects on nearby equipment. As a result, when the solenoid valve is continuously energized over long periods of time, or when the solenoid valve is energized for longer periods than it is non-energized on any day, a good suggestion is to keep the solenoid valve in a normally open (NO) specification as one possible method of reducing the amount of time the valve is energized. For details, consult us.
- After wiring operations, always check to ensure that no wiring connection errors exist before turning ON the power.
- Do not collect the exhaust lines for air cylinders, etc. with pilot exhaust lines for solenoid valves into the same piping, etc. Interference in the exhaust could result in erratic operation.
- When using the valve in a manifold, be aware when operating an air cylinder or performing air blowing operations that back pressure could cause erratic operations of the cylinder or erroneous air delivery from the air blow port. Caution is particularly needed when using valves with 3-position exhaust center specification, when operating single acting cylinders, or when operating a cylinder and blowing air using the same manifold. If there are concerns in this area, take such countermeasures as using individual exhaust spacers or back pressure prevention valves.

### CAUTION

- When mounting the product, leave room for adequate working space around it. Failure to ensure adequate working space will make it more difficult to conduct daily inspections or maintenance, which could eventually lead to system shutdown or damage to the product.
- For mounting or transport of heavy products, use a lift, supporting tool, or several people, to provide firm support, and proceed with due caution to ensure personal safety.
- Do not bring magnetic media, within 1 meter [3.28 ft.] of the product. There is the possibility that the data on the magnetic media will be destroyed due to the magnetism of the magnet.
- If leakage current is flowing in the control circuit, there is a possibility of the product performing an unintended operation. Take measures against current leaking in the control circuit, to ensure that the leakage current value does not exceed the allowed range in the product specifications.
- Do not block the product's breathing holes. Pressure changes occur due to changes in volume during operation. Blocking the breathing holes destroys the pressure balance, and could cause failure of the intentional operation, equipment damage, or personal injury.

- Do not use the solenoid valve in locations subject to large electrical currents or magnetic fields. It could result in erratic operation.
- Oily materials from the compressor (excluding the oil-free compressor) can cause drastic deterioration in product performance, and even a functional shutdown. Always install a mist filter before pneumatic equipment to remove the oily component.
- The properties of the lubrication oil can change when used in dry air where dew point temperatures is lower than  $-20^{\circ}\text{C}$  [ $-4^{\circ}\text{F}$ ]. It could result in degraded performance or in functional shutdown.
- Do not use the product in locations that are subjected to direct sunlight (ultraviolet ray), to dust, salt, or iron powder, high temperature, high humidity or in media or ambient atmospheres that include organic solvents, phosphate ester type hydraulic oil, sulfur dioxide, chlorine gas, acids, etc. It could lead to an early shutdown of some functions or a sudden degradation of performance, and result in reduced operating life. For materials used, see Major Parts and Materials.
- Always carefully wash your hands after touching oil or grease used in the valves. If you smoke a cigarette while there is oil or grease remains on your hands, oil or grease transferred to the cigarette could catch fire and emit toxic gases.

### ATTENTION

- When considering the possibility of using this product in situations or environments not specifically noted in the Catalog or Instruction Manual, or in applications where safety is an important requirement, such as in an airplane facility, combustion equipment, leisure equipment, safety equipment and other places where human life or assets may be greatly affected, take adequate safety precautions such as application with enough margins for ratings and performance or fail-safe measures. Be sure to consult us with such applications.
- Always check the Catalog and other reference materials for product wiring and plumbing setup.
- Install a muffler, etc. on the exhaust port. It is effective in reducing exhaust noise.
- When handling the product, wear protective gloves, safety glasses, safety shoes, etc. to keep safety.
- When the product can no longer be used or is no longer needed, dispose of it appropriately as industrial waste in accordance with the Waste Disposal and Public Cleaning Law, and other ordinances and regulations imposed by local government authorities. As incineration disposal of oil or grease used in the valves will generate corrosive, toxic hydrofluoric acid (HF), dispose of these compounds in an acid-resistant incinerator with toxic removal facilities. For large volumes, use a registered industrial waste disposer.
- Pneumatic equipment can exhibit degraded performance and function over its operating life. Always conduct daily inspections of the pneumatic equipment, and confirm that all requisite system functions are satisfied, to prevent accidents from happening.
- Air leaks from the valve are not zero. For application of requiring holding pressure (including vacuum) inside the pressure vessel, consider adequate margin of capacity and holding time in design of the system.
- When using a valve for air blowing, use an external pilot specification. With the internal pilot specification, air blowing can cause a pressure drop that could affect valve operations.
- For inquiries about the product, consult your nearest Koganei sales office, or Koganei overseas department. The address and telephone number is shown on the back cover of this catalog.

### OTHERS

- Always observe the following items.
  1. When using this product in pneumatic systems, always use genuine KOGANEI parts or compatible parts (recommended parts).  
When conducting maintenance and repairs, always use genuine KOGANEI parts or compatible parts (recommended parts). Always observe the required methods and procedure.
  2. Do not attempt inappropriate disassembly or assembly of the product relating to basic configurations, or its performance or functions.

Koganei cannot be responsible if these items are not properly observed.



### General Precautions

#### Mounting

1. While any mounting direction is allowed, be sure to avoid strong shocks or vibrations applied directly to the body.
2. Avoid using in the locations and environment listed below, as it could result in malfunction of the valve. If use in such conditions is unavoidable, always provide a cover or other adequate protective measures.
  - Location directly exposed to water drops or oil drops
  - Environment where a valve body is subject to dew condensation
  - Location directly exposed to machining chips, dust, etc
3. In piping connection with valves, flush the tube completely (by blowing compressed air) before piping. Intrusion of machining chips or sealing tape, rust, etc., generated during plumbing could result in air leaks and other defective operations.
4. Never use the valve with the 4(A) and 2(B) ports vented to the atmosphere.
5. When mounting a valve inside a control panel, or when energizing time is long, make adequate consideration for ventilation and other heat dissipation measures.
6. When adding or subtracting units in the manifold, or replacing a fitting block, be sure to tighten to within the specified tightening torque range.

#### Media

1. Use air for the media. For the use of any other media, consult us.
2. Air used for the cylinder should be clean air that contains no deteriorated compressor oil, etc. Install an air filter (filtration of 40 µm or less) near the valve to remove collected liquid or dust. In addition, drain the air filter periodically.
3. When supply pressure is low, use piping for the 1(P) port with sufficient tube size.

#### Lubrication

Can be used without lubrication due to the factory lubricant (grease). When the pneumatic products require lubrication, use Turbine Oil Class 1 (ISO VG32) or the equivalent. In addition, cutting off oil feed while an operation is in progress could lead to malfunction due to the dissipation of the factory lubricant (grease). As a result, always keep the oil feed running continuously. However, use caution since excessive oil feed can also be a cause of malfunction. Avoid using spindle oil or machine oil.

#### Atmosphere

The product cannot be used when the media or ambient atmosphere contains any of the substances listed below.

Organic solvents, phosphate ester type hydraulic oil, sulphur dioxide, chlorine gas, or acids, etc.

#### Wiring

After wiring, check that there is no error in the wiring connections.

#### Piping

Since the 1(P), 3(R2), and 5(R1) ports are on both ends of the manifold, piping direction can be selected depending on the application (in monoblock manifolds).

At shipping, plugs are temporarily screwed in ports at one end, but are not firmly tightened. Regardless of which end piping is connected, always remove the plugs, use sealing tape or apply other sealing agent, and securely tighten the plugs into the unused ports.

#### 1. Sealing tape wrapping method

- ① Before piping, perform air blowing (flushing) or cleaning to eliminate any machining chips, cutting oil, or dust, etc., remaining inside the pipes.
- ② When screwing in piping or fittings, caution should be taken to avoid letting machining chips or sealing materials from entering into the valves. When using sealing tape, wrap it so that 1.5~2 screw threads remain.

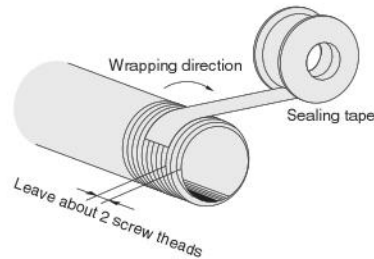

#### Prevention of erratic operation in the manifold type

When using a manifold-type valve to operate an air cylinder, or to perform air blowing or similar operations, erratic operation due to exhaust interference or malfunction due to insufficient flow rate could occur. When using the manifold type valves, be sure to take the following measures beforehand.

#### 1. Erratic operation due to large exhaust flow rate

**Cause:** When a large-bore cylinder is operating, or multiple cylinders are operating at the same time, the exhaust air in the collective exhaust can flow backward through the exhaust ports of other solenoid valves. This could lead to an obstruction of the operations of other cylinders and may cause erratic operation in single acting cylinders or an Air Hand module due to inflow of air into them. The erratic operation is caused by insufficient manifold exhaust (large exhaust resistance).

**Countermeasure:** To reduce the exhaust resistance, for the base monoblock manifold, vent the exhaust ports at both ends. For the split manifold, attach piping blocks to both ends to exhaust from both sides. If still affected even after exhausting from both ends, consider splitting the manifold, or if using a split manifold, either install a port isolator to separate the exhaust, or use a back pressure prevention valve.

#### 2. Malfunctions due to insufficient pressure or flow rate

**Cause:** When operating a large-bore cylinder, operating multiple cylinders at the same time, or using circuits to perform air blowing, etc., sudden consumption of air with the manifold type can result in insufficient flow rate to nearby cylinders, causing a reduction in speed or a shortage of thrust. In addition, in the pilot-type valve, this sudden consumption can lead to a pressure shortage for the pilot signals, and it causes erratic operations in the main stem.

**Countermeasure:** Because it causes insufficient air delivery to the manifold, supply air from both ends of the manifold, or from the piping block 1(P) port mounted on both sides. For air blowing, consider either dividing the air lines for independent use, or use of an external pilot valve.

**5-port, 2-position**

When set as a single solenoid or T0 type

When set as a double solenoid

F□T1□-A1  
(De-energized)

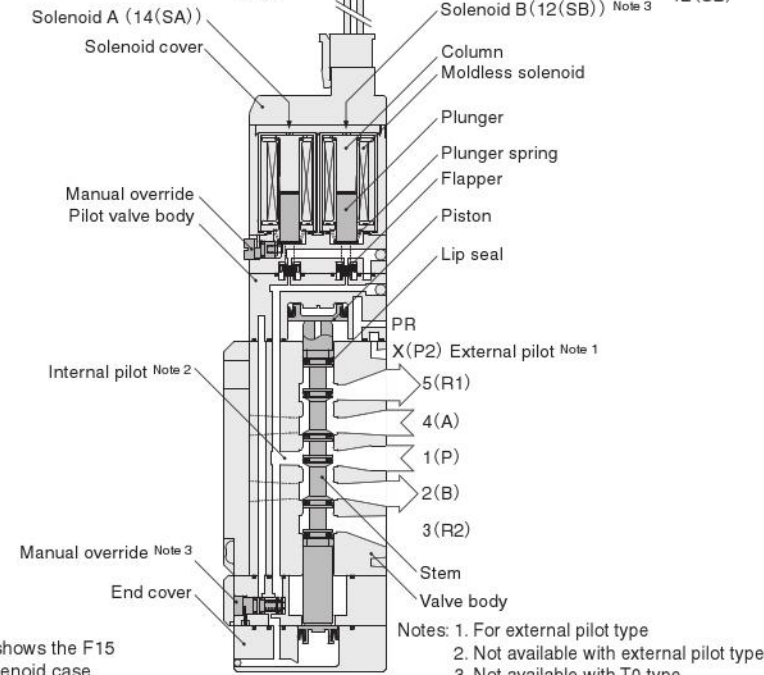

\*Diagram shows the F15 single solenoid case.

Notes: 1. For external pilot type  
2. Not available with external pilot type  
3. Not available with T0 type

Remark: 1. When using a 5-port valve as a 3-port valve, see p.23.  
2. For the F18 series, some of the shapes differ from the diagram. In addition, the F18 series is a molded solenoid.

**Major Parts and Materials**

Parts	Materials	
Valve	Body	Aluminum die-casting
	Stem	Aluminum alloy <sup>Note</sup>
	Lip seal	Synthetic rubber
	Flapper	
	Sub-base	Aluminum alloy (anodized)
	Plunger	Magnetic stainless steel
	Column	Plastic
End cover		
Manifold	Body	Monoblock Aluminum alloy (anodized)
	Split type	Plastic
	Block-off plate	Mild steel (nickel plated)
	Seal	Synthetic rubber

Note: Some F10 and F15 Series models use plastic for the stem material.

**5-port, 3-position**

(Both 14 (SA) and 12 (SB) are de-energized)

Closed center  
F□T3□-A1

Exhaust center  
F□T4□-A1

Pressure center  
F□T5□-A1

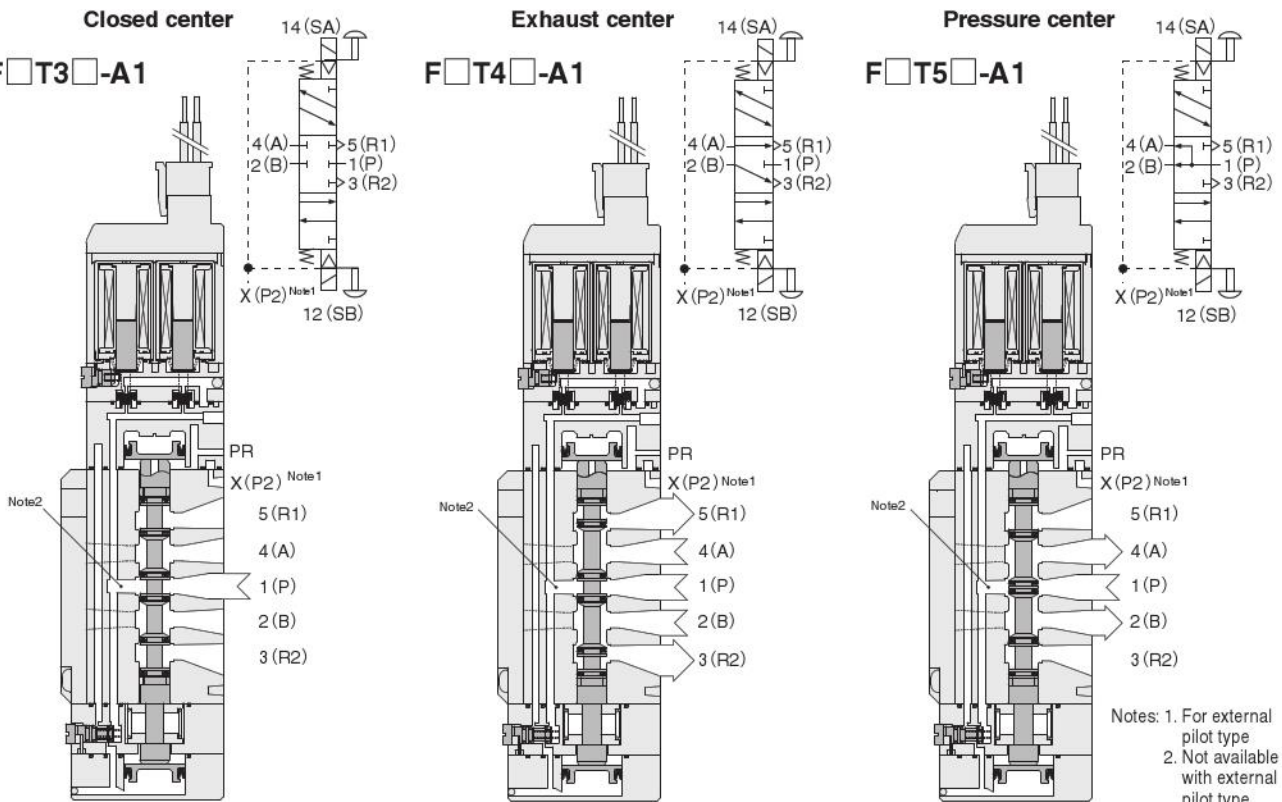

Notes: 1. For external pilot type  
2. Not available with external pilot type

# Tandem 3-port, 4-position (F10, F15 series only)

(Both 14 (SA) and 12 (SB) are de-energized)

Normally closed (NC) & normally closed (NC)

**F□TA-A1**

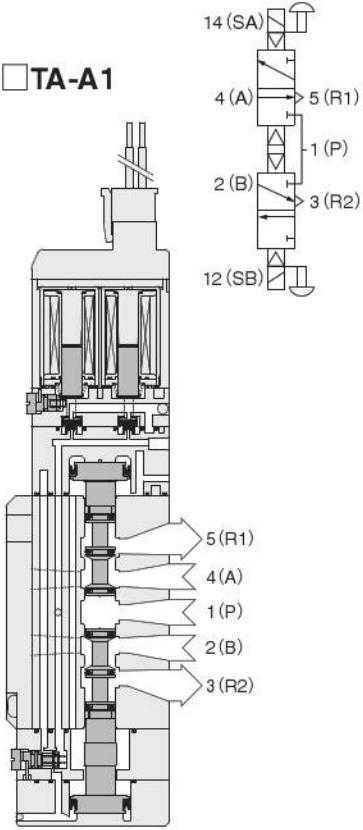

Normally open (NO) & normally open (NO)

**F□TB-A1**

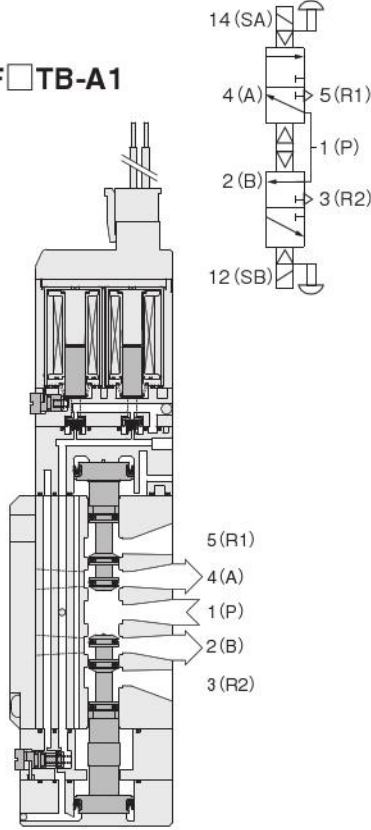

Normally closed (NC) & normally open (NO)

**F□TC-A1**

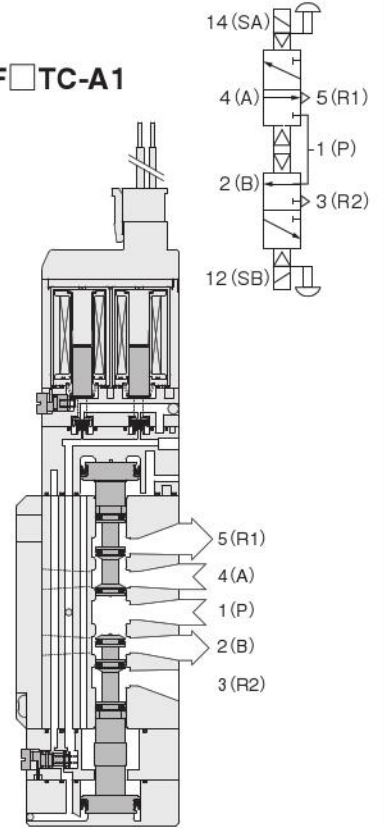



## Solenoid

### Single and double solenoid switching procedure

By switching the manual override, model F□T1 (2-position valve) can be used as either a single solenoid valve or a double solenoid valve (switching not possible with a 3-position valve and a tandem 3-port valve). Note that the F□T1 is set to the single solenoid specification at shipping.

#### Switching from a single solenoid valve to a double solenoid valve

1. As shown in Fig.1, insert the flatblade edge of a small screwdriver into the gap between the valve and the cover, and then peel it off and remove the cover.

**Caution:** As shown in Fig.1, make sure to insert a small screwdriver from the side of the valve cover. The cover claw may be damaged when the cover is removed from the direction of the valve stem. Never remove the cover for any reason other than valve function switching.

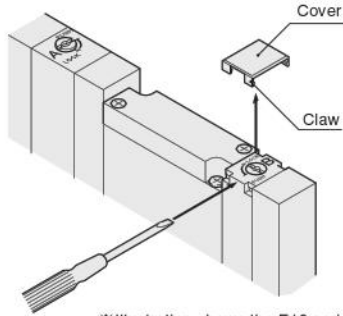

※Illustration shows the F10 series.

Figure 1

2. As shown in Fig.2, use a small screwdriver, etc. to turn the manual override on the B side by 90 degrees in the counterclockwise direction, so that the manual override button's slit is horizontal, as shown on the right side of the figure. Then the unit can be used as a double solenoid valve. When using it as a double solenoid valve, the button is used as the manual override button for the B side.

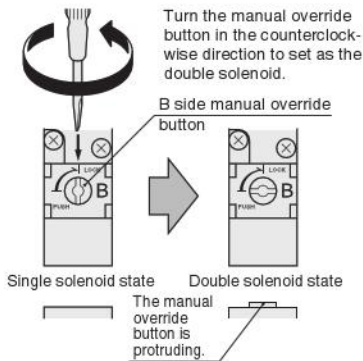

Figure 2

**Caution:** When using it as a double solenoid valve, do not attach the cover that was removed in Fig. 1.

#### Switching from a double solenoid valve to a single solenoid valve

As shown in Fig.3, use a small screwdriver, etc. to push lightly against the manual override button, and then turn it by 90 degrees in the clockwise direction, so that the manual override button's slit is in the vertical direction, and then attach the cover.

**Caution:** The cover has directionality (F15 and F18 series only). When attaching, always align the detent on the back of the cover with the manual override button's slit, as shown in Fig.4.

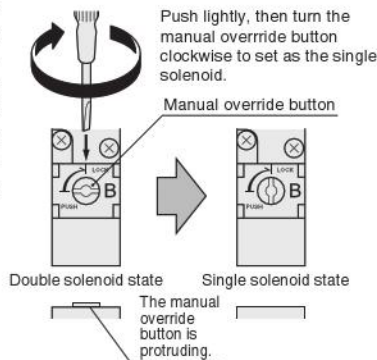

Figure 3

#### Note about the wiring for the above switching

See the "Wiring instructions" to the right.

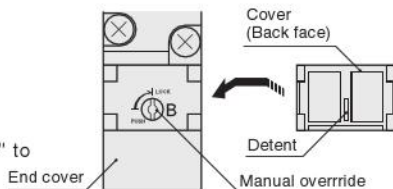

Figure 4

### Wiring instructions (When used as a single unit, non-plug-in type manifold)

#### 1. Attaching and removing plug connector

Use fingers to insert the connector into the pin, push it in until the lever claw latches onto the protruded section of the connector housing, and complete the connection.

To remove the connector, squeeze the lever along with the connector, lift the lever claw up from the protruded section of the housing, and pull it out.

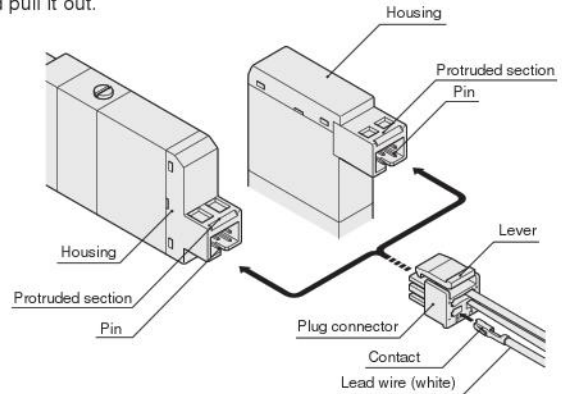

**Cautions:** 1. When removing the connector, confirm that the lever claw is positively disengaged from the protruded section before pulling out. The housing may be damaged if it is pulled out while engaged with the protruded section.

2. The plug connector lead wires for model F□T1 (2-position valve) are set to the single solenoid specification at shipping (for plug connector types). When switching from a single solenoid to a double solenoid specification for use, disconnect the plug connector from the valve, check the hook directions on the lead wire (white) with the contacts, and then insert the lead wire into the plug connector's B side □ hole (see the illustration above). Use the same procedure to switch the manifold type single solenoid to a double solenoid specification.

3. When using the plug-in type manifold, caution should be exercised that even if the valve has been switched to a double solenoid, no power will be supplied to the B side solenoid unless the valve base wiring is set to the double wiring.

#### 2. Attaching and removing plug connector and contact

##### ● Attaching

Insert the contact with a lead wire into a plug connector □ hole until the contact hook latches on the connector and is secured to the plug connector. Confirm that the lead wire cannot be easily pulled out (see the diagram below).

##### ● Removing

To remove it, insert a tool with a fine tip (such as a small screwdriver) into the rectangular hole on the side of the plug connector to push down on the hook, and then pull out the lead wire. When re-using the contacts, restore the hook back so that they spread outward.

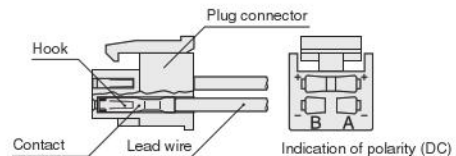

#### 3. Common terminal and short bar

A short bar is attached to the plug connector to ensure that the solenoid A and B wiring are positive common. Do not remove the short bar.

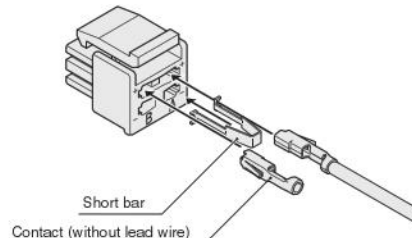

#### 4. Crimping of lead wire and contact

To crimp lead wires into contacts, strip off 4 mm [0.16 in.] of the insulation from the end of the lead wire, insert it into the contact, and crimp it. Be sure to avoid catching the insulation on the exposed wire crimping section.

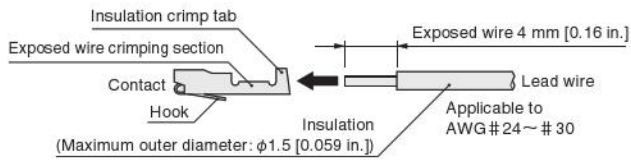

- Cautions:**
1. Do not pull hard on the lead wire.
  2. For crimping of lead wire and contact, always use a dedicated tool.  
Contact: Model 706312-2MK Manufactured by Sumiko Tech, Inc.  
Crimping tool: Model F1 (for 706312-2MK) Manufactured by Sumiko Tech, Inc.

#### 5. F10, F15 Common connector assembly

Using a common connector assembly for solenoid valves for a manifold provides common wiring for all the solenoid valves and greatly reduces wiring work. The common connector assembly types are determined by looking at them from the lead wire side; the right end one is A type, the left end one is C type, and all the others are B type (see Fig. 5). (see the illustration below).

##### ● For positive common

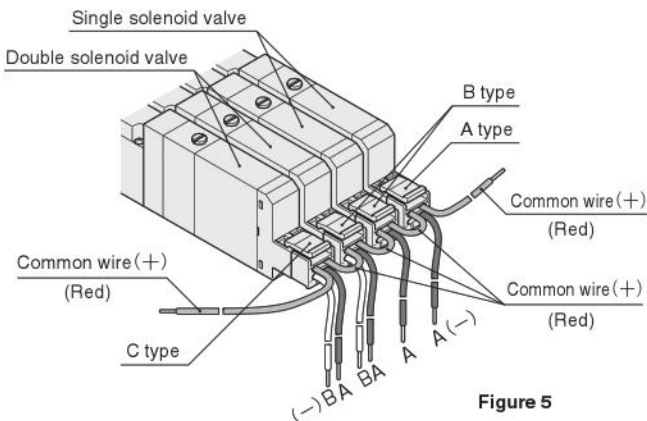

Figure 5

##### ● For negative common (F10, F15 series only) Note

In the new F10, F15 series, you can order the separately sold common connector assembly for use with negative common specification.

Note: Cannot be used with the conventional F10, F15 series.

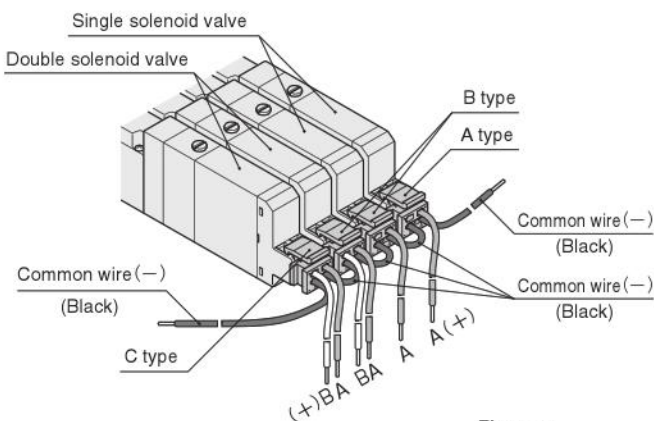
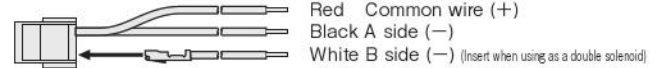

Figure 6

If ordering the common connector assembly, order from the common connector assemblies listed below.

##### ● For positive common (F10 and F15 series)

###### A type Model: JAZ-PA□<sup>※</sup>



Red Common wire (+)  
Black A side (-)  
White B side (-) (Insert when using as a double solenoid)

###### B type Model: JAZ-PB□<sup>※</sup>

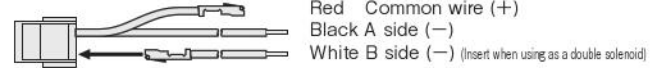

Red Common wire (+)  
Black A side (-)  
White B side (-) (Insert when using as a double solenoid)

###### C type Model: JAZ-PC□<sup>※</sup>



Red Common wire (+)  
Black A side (-)  
White B side (-) (Insert when using as a double solenoid)  
Red Common wire (+)

Note: White lead wire is not available for JAZ0-P□□.  
<sup>※</sup> Lead wire length **Blank:** 300 mm [11.8 in.]  
**3:** 3000 mm [118 in.]

##### ● For negative common (F10 and F15 series)

###### A type Model: JAZ-MA□<sup>※</sup>



Black Common wire (-)  
Red A side (+)  
White B side (+) (Insert when using as a double solenoid)

###### B type Model: JAZ-MB□<sup>※</sup>



Black Common wire (-)  
Red A side (+)  
White B side (+) (Insert when using as a double solenoid)

###### C type Model: JAZ-MC□<sup>※</sup>



Black Common wire (-)  
Red A side (+)  
White B side (+) (Insert when using as a double solenoid)  
Black Common wire (-)

###### Single negative common plug connector unit

Model: JAZ-CM□<sup>※</sup>

<sup>※</sup> Lead wire length **Blank:** 300 mm [11.8 in.]  
**3:** 3000 mm [118 in.]

#### 6. Common connector assembly for F18 (positive common specification only)

For adding units after mounting the connector assembly for the manifold, order the appropriate common connector assembly shown below.

###### A type Model: FZ-PA□<sup>※</sup>



Red Common wire (+)  
Black A side (-)  
White B side (-) (Insert when using as a double solenoid)

###### B type Model: FZ-PB□<sup>※</sup>

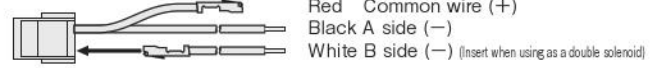

Red Common wire (+)  
Black A side (-)  
White B side (-) (Insert when using as a double solenoid)

###### C type Model: FZ-PC□<sup>※</sup>



Red Common wire (+)  
Black A side (-)  
White B side (-) (Insert when using as a double solenoid)  
Red Common wire (+)

Note: White lead wire is not available for FZ0-P□□.  
<sup>※</sup> Lead wire length **Blank:** 300 mm [11.8 in.]  
**3:** 3000 mm [118 in.]

The common connector assembly types are determined by looking at them from the lead wire side; the right end one is A type, the left end one is C type, and all the others are B type (see Fig. 5).

#### 7. Cautyre cable

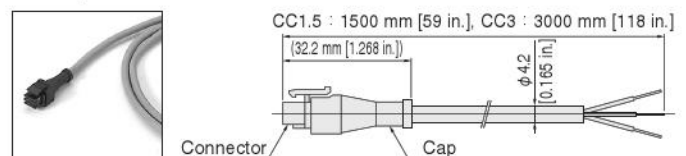

**Caution:** Exercise caution that this is not dust-proof and drip-proof specification.

# Handling Instructions and Precautions

## Internal circuit

●For F10, F15 Series

### Positive common

Voltage specification	Internal circuit
24VDC 12VDC	<p>(Inside the connector)</p>
Low-current type 24VDC	<p>(Inside the connector)</p>

### Negative common (-129W)

Voltage specification	Internal circuit
24VDC 12VDC	<p>(Inside the connector)</p>
Low-current type 24VDC	<p>(Inside the connector)</p>
100VAC 120VAC	<p>(Inside the connector)</p>

●For F18 Series

### Positive common

Voltage specification	Internal circuit
24VDC 12VDC	<p>(Inside the connector)</p>

### Negative common (-129W)

Voltage specification	Internal circuit
24VDC 12VDC	<p>(Inside the connector)</p>
100VAC 120VAC	<p>(Inside the connector)</p>

- Cautions:**
1. Do not apply megger between the pins.
  2. Leakage current inside the circuit could result in failure of the solenoid valve to return, or in other erratic operation. Always use at less than the allowable leakage current shown in the solenoid specifications on p.106, 138, and 172. If circuit conditions etc. cause the leakage current to exceed the allowable leakage current, consult us.
  3. For the double solenoid specification, avoid energizing both solenoids at the same time (except for tandem 3-port valve).
  4. For the housing color, standard type is blue and low-current type is light blue (F18 is black).
  5. The low-current type will not operate if the power voltage is gradually increasing. Always apply a suitable voltage.
  6. For the T0 type, there is one solenoid.

● For F15, 18 Series DIN connector type

Voltage specification	Internal circuit
24VDC 12VDC	<p>DIN connector type with indicator Order code:-39L</p> <p>(Inside of the DIN connector)</p>
120VAC 240VAC	<p>DIN connector type with indicator Order code:-39L</p> <p>(Inside of the DIN connector)</p>

- Cautions:**
1. Do not apply megger between the pins.
  2. Leakage current inside the circuit could result in failure of the solenoid valve to return, or in other erratic operation. Always use at less than the allowable leakage current shown in the solenoid specifications on p.139, and 173. If circuit conditions etc. cause the leakage current to exceed the allowable leakage current, consult us.
  3. For the double solenoid specification, avoid energizing both solenoids at the same time.

**PC board manifold**

When connecting a power line to the power supply terminal on the PC board manifold, care should be taken in regard to the following points when connecting.

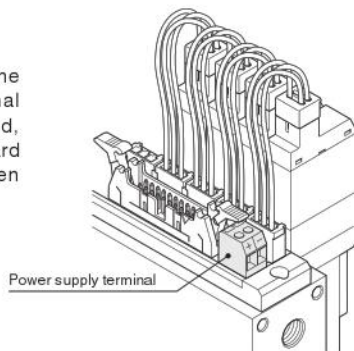

Terminal screw tightening torque: 0.4 N·m [3.5 in·lbf]  
 Stripped wire length: 7 mm [0.28 in.]  
 Connecting wire size: 0.13~2.5 mm<sup>2</sup> [0.00020~0.00388 in.<sup>2</sup>]  
 AWG: No.26...14

When planning to use crimp-style terminals, use bar terminals.  
 Recommended crimp-style terminals (bar terminals):  
 Manufactured by Nichifu, Inc.  
 Model BT1.25-9-1 (for 0.25~1.65 mm<sup>2</sup> [0.00039~0.00256 in.<sup>2</sup>])

**Wiring of the terminal block**



Care should be taken with the terminal screw tightening torque. Overtightening beyond the tightening torque could result in breakage.

Terminal screw tightening torque: Max. 49.0 N·cm [4.3 in·lbf].

**Operating principles for the low-current type**

The low-current type uses a timer circuit, as shown on the previous page, that achieves power consumption savings by switching to a holding operations mode after a certain period of time to operate at about 1/4 of the starting power consumption.

● Power waveform

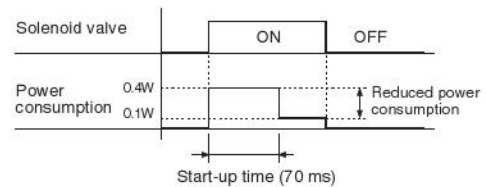

**Precautions for use of the double solenoid**

When using models F□T1 or F□T2 (2-position valve) as double solenoid valves, caution should be exercised as energizing the A side solenoid or pushing the manual override button on the A side, while pushing the B side manual override button or in a locked state, or energizing the solenoid on the B side, will cause the valve to switch over the valve position. (At that time, the valve will operate in the same state as the single solenoid valve.)



**Manual override**

**Manual override button (locking and non-locking dual use type)**

To lock the manual override, use a small screwdriver to push down the manual override button all the way down and turn it clockwise 90 degrees. To release the manual override, turn the button 90 degrees counterclockwise, which will release the manual override lock by spring action and return it to its normal position. To operate the unit in the same way as the non-locking type, leave the manual override button unturned.

- Cautions:**
1. The F series valves are pilot type solenoid valves. As a result, the manual override cannot switch the main valve without air supplied from the 1(P) port (X(P2) port for external pilot type).
  2. Always release the lock of the manual overrides before commencing normal operation. Caution should be exercised to release the lock of the manual override on the B side that also works as the switching button between the single solenoid and double solenoid (excluding the 3-position valve and tandem 3-port valve). For details, see "Switching from a double solenoid valve to a single solenoid valve" on p.18.
  3. Do not attempt to operate the manual override button with a pin or other object having an extremely fine tip. It could damage the manual override button.
  4. Take care to avoid excessive turning of the manual override button, it could damage the override.
  5. When operating the solenoid valve's manual override button for maintenance etc. always confirm that the solenoid valve's override button has been restored to its normal position, and that the main valve is in the required switching position before restarting operations.

## Manual override lever (locking and non-locking dual use type)

To lock the manual override lever, use fingers to push the lever all the way down and turn it clockwise 90 degrees. To release the manual override, turn the lever 90 degrees counterclockwise, which will release the manual override lock by spring action and return it to its normal position. To operate the unit in the same way as the non-locking type, leave the lever unturned.

**Caution:** Model F□T1 (2-position valve) has a manual override lever on the A side, and a manual override button with cover on the B side.  
 Model F□T2 has a manual override lever on the A side only, and a manual override button on the B side.  
 The 3-position valve has manual override lever on both the A and B sides.

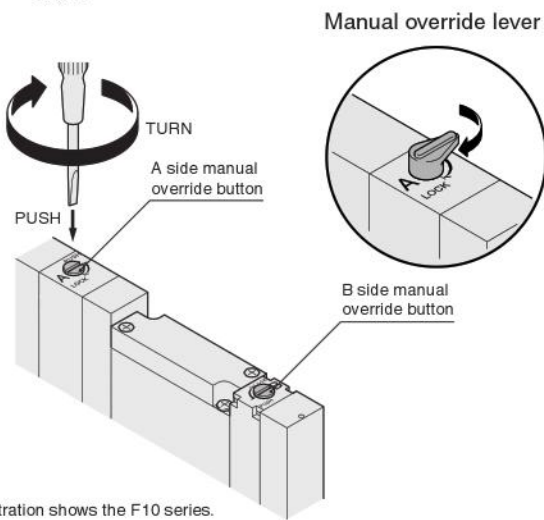

※Illustration shows the F10 series.

## Locking protruding type -83

Use a small screwdriver or the fingers to press down and rotate the manual override button by at least 45 degrees, to lock in place. Either rotation direction is acceptable. In the locked position, rotate further the manual override which will release the manual override lock by spring action and return it to its normal position. If the manual override is not rotated, the unit can be operated in the same way as the non-locking type.

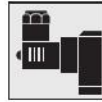
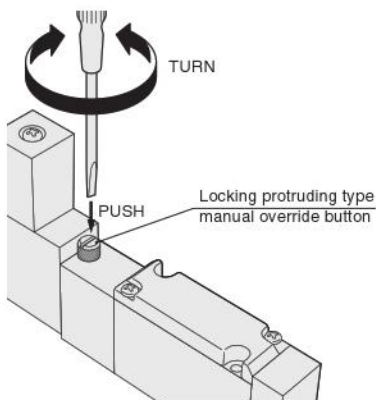

## DIN connector

### Wiring instructions

Remove the cover mounting screws, and lift the terminal cover off from the solenoid. Use a screwdriver, etc., to push strongly against the terminal body through the hole of the terminal cover's mounting screw, and remove the terminal body.

Slip a cable ground, washer, and cable gasket over a cable, insert the cable into the terminal cover's wiring port, and connect the lead wire to the terminal body (screwdriver blade width of about 3 mm [0.12 in]).

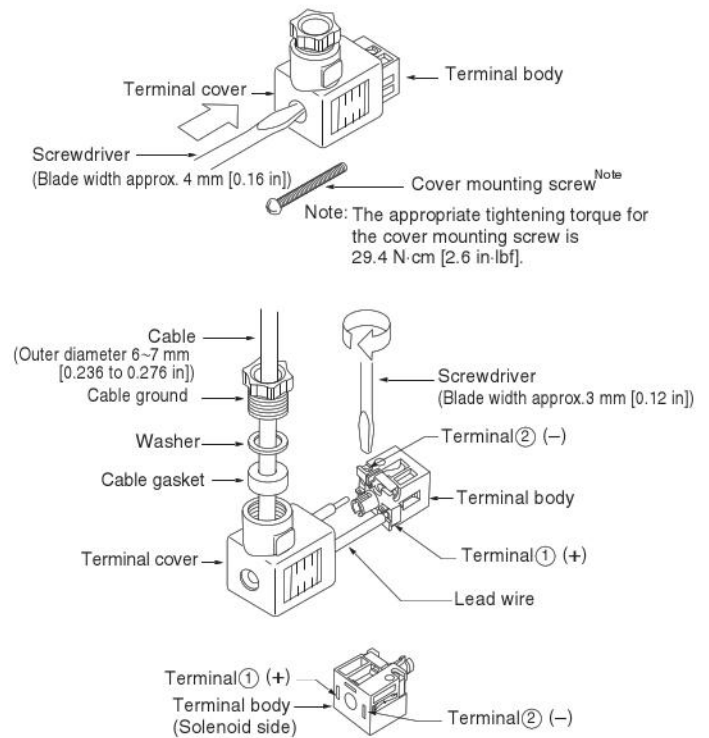

※For the DC24V solenoid with surge suppression, connect (+) to terminal ①, and (-) to terminal ②.



## 3-port valves

While the F series is a 5-port valve (excluding tandem 3-port valve), it can be used as a normally closed (NC) or normally open (NO) 3-port valve by plugging one of either outlet port 4(A) or 2(B). In this case, leave the exhaust ports 3(R2) and 5(R1) open for use. It can also be used as a double solenoid type 3-port valve.

### When using a single use fitting block or female thread block for 3-port

In the F10 and F15 series, a single use fitting block and female thread block for 3-port with one plugged port can be selected at the time of order. (Note: Not available for F18 series.)

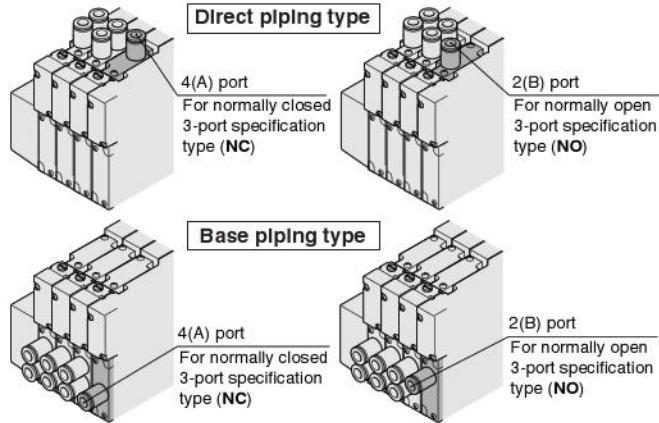

Fitting type	-*※ A	-*※ B
Switching type	Normally closed (NC)	Normally open (NO)
For single solenoid setting		
For double solenoid setting		

### When using a plug

The F10, F15, and F18 series can be used as either a normally closed (NC) or normally open (NO) 3-port valve by plugging either outlet port of 4(A) or 2(B).

Plug position	When the 2(B) port is plugged	When the 4(A) port is plugged
Switching type	Normally closed (NC)	Normally open (NO)
For single solenoid setting		
For double solenoid setting		

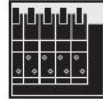

## Manifold

### Attaching and removing valves

To remove the valve body from the sub-base or manifold, loosen the valve mounting screws (2 places), and lift it up in the direction of the arrow (see the illustration at right). To install it, reverse the above procedure. The recommended tightening torques for the valve mounting screws are as shown below.

※ Illustration shows the F10 series (split manifold).

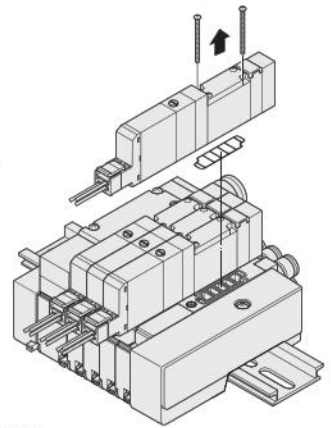

N · cm [in · lbf]

Series	Recommended tightening torque
F10	17.6 [1.6]
F15	49.0 [4.3]
F18	49.0 [4.3]

### Precautions for using manifold

Observe the following precautions when using the split type and serial transmission compatible manifold (except for the monoblock manifold and PC board manifold).

- When using the direct piping type manifold  
Avoid using valves at an operating frequency exceeding 2 Hz, as such use can result in heat-related breakdowns.
- When using the base piping type manifold  
When plugs have been attached on the 4(A) and/or 2(B) ports, avoid using valves at an operating frequency exceeding 2 Hz, as such use can result in heat-related breakdowns.

### Stop valve usage procedure (F10, F15 series)

Mount a stop valve on a manifold to stop the air supply to valves on the individual station. For the operation procedure, use a small screwdriver or the hand to press down and rotate the stop valve manual knob clockwise 90 degrees to lock in place, shutting off the air supply. In the locked position, rotate the stop valve manual knob counterclockwise 90 degrees, and air pressure returns the stop valve manual knob to its original position, releasing the lock. Note that use of the stop valve reduces the flow rate volume by about 30%.

Stop valve manual knob

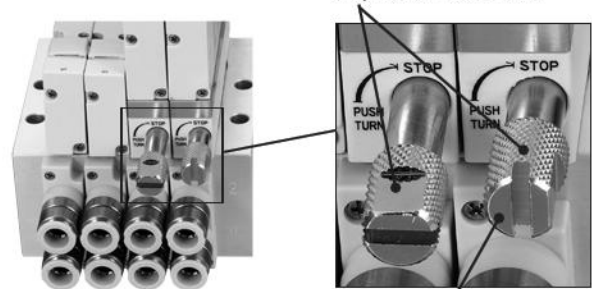

Stop valve manual knob is locked, and air supply shut off.

- Cautions:**
1. Do not disassemble the stop valve.
  2. When using a stop valve to remove the valve, be careful of residual pressure in the affected station.
  3. When using a stop valve to remove the valve, be aware that exhaust from other stations can be exhausted through the stop valve's exhaust hole. If this will cause a problem during use, when ordering the manifold, select the back pressure prevention valve (-E1).
  4. To use a stop valve in combination with a back pressure prevention valve, select the combination when ordering the manifold. The back pressure prevention valve (F1□Z-E1) in additional parts cannot be installed after purchase.
  5. Do not release the locked stop valve manual knob when valves have been removed by using the stop valve.

# Handling Instructions and Precautions

## Port isolator

In the split manifold, installing port isolators to the 1(P), 3(R2) and 5(R1) ports between each station isolates the air path between stations equipped with port isolators and stations with smaller station numbers. However, a piping block must be placed on both ends.

- Port isolator for the 1(P) port (Model : F□Z-SP) — Can supply two different pressures
- Port isolators for the 3(R2), 5(R1) ports (Model : F□Z-SR) — Can isolate exhaust air (prevents exhaust interference)
- Port isolators for the 1(P), 3(R2), 5(R1) ports (Model : F□Z-SA) — Can supply two different pressures, and can isolate exhaust air (prevents exhaust interference)

※□ denotes valve size.

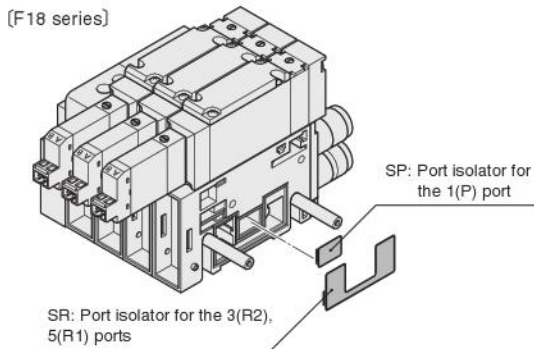
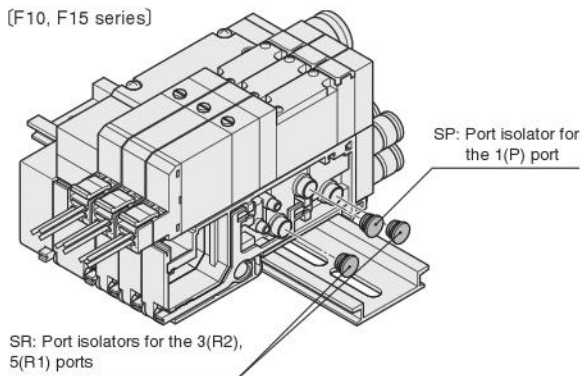

**Caution:** Installing port isolators requires the disassembly and re-assembly of manifolds. See the disassembly illustration, unit adding procedure, and cautions on p.28-33. However, since the F18 series serial transmission compatible manifold cannot be disassembled, port isolators cannot be installed on it after purchase.

### Precautions for the use of individual air supply and exhaust spacers

By mounting an individual air supply or exhaust spacer on the manifold, the air supply or exhaust can be operated individually on the unit. It is also effective in preventing erratic operation due to back pressure. Caution should be exercised when spacers are used, as the effective area is reduced by about 30%. If mounting additional spacers to an existing unit, observe the following items:

#### ● Spacer mounting procedure (F10 series)

- Loosen the valve mounting screws where the individual air supply or exhaust spacer will be installed, and remove the valve.
- Install the gaskets and exhaust valve provided with the individual air supply or exhaust spacer, and use the mounting screws provided to secure the valve on the manifold (see Fig. 7).

Remark: When attaching fittings to the F10 spacer, use the recommended fittings shown below:

TSH4-M5M, TSH4-M5, TSH6-M5M, TS4-M50, TS4-M5M

#### ● Spacer mounting procedure (F 15 and F18 series)

- Loosen the valve mounting screws where the individual air supply or exhaust spacer will be installed, and remove the valve.
- Open the cover of the manifold, and pull out the plug-in connector in the rear side direction (for the plug-in type) (see Fig. 8).
- Insert the plug-in connector firmly into the connector attaching section of the individual air supply or exhaust spacer, and then close the cover, while watching to ensure that the lead wires are not caught by the cover (for the plug-in type) (see Fig. 9).
- Attach the gasket and exhaust valve provided with the individual air supply or exhaust spacer, and use the mounting screws provided to mount the valve on the manifold.

**Cautions:** Locations where the spacers are mounted make the valve height higher by the height of the spacer (see the dimensions below).

#### ● Muffler for the individual exhaust spacer

A muffler for the individual exhaust spacer is available. For dimensions, see p.133, 166, and 196.

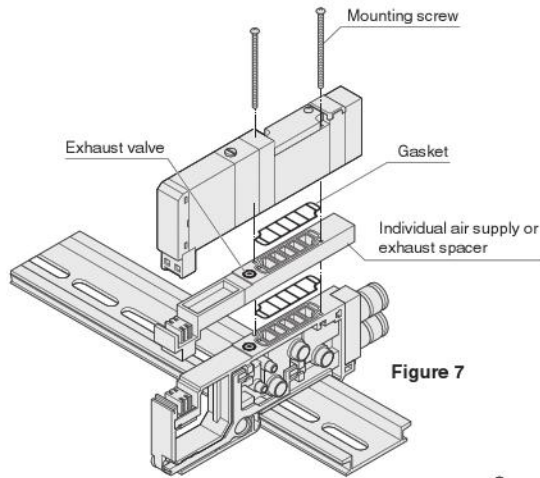
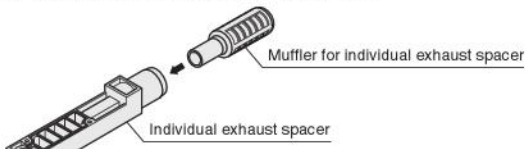

Figure 7

#### F10 series

(Illustration shows the split manifold plug-in type)

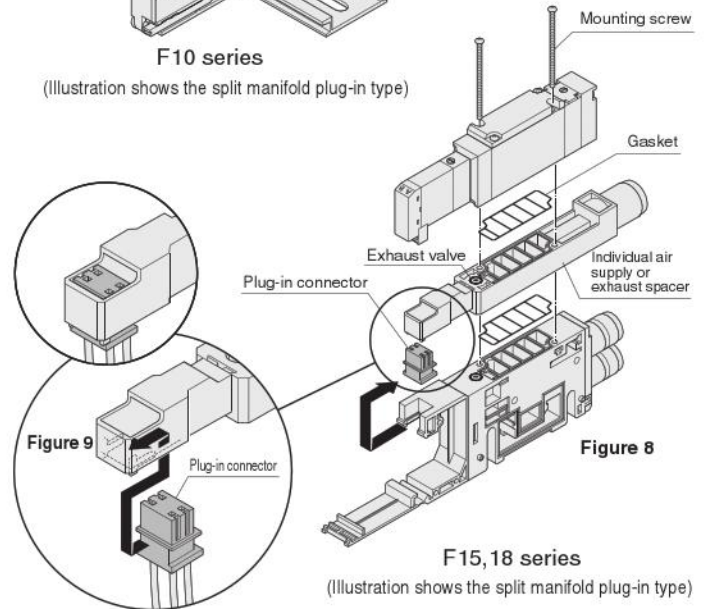

Figure 8

#### F15, 18 series

(Illustration shows the split manifold plug-in type)

#### ● Dimensions Unit: mm [in.]

##### F10Z-N□□ (For F10 series) Mass 7 g [0.25 oz.]

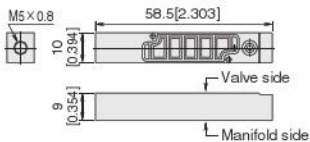

##### F10Z-P□□ (For F10 series) Mass 9 g [0.32 oz.]

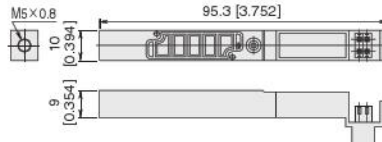

##### F15Z-N□□ (For F15 series) Mass 26 g [0.92 oz.]

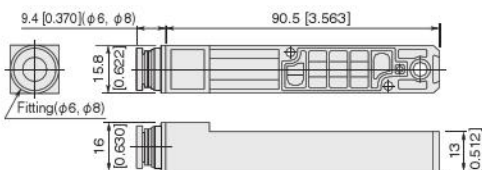

##### F15Z-P□□ (For F15 series) Mass 29 g [1.02 oz.]

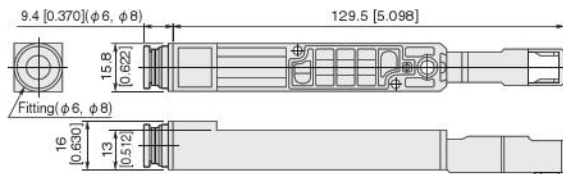

##### F18Z-N□□ (For F18 series) Mass 41 g [1.45 oz.]

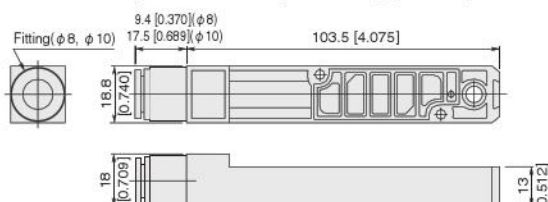

##### F18Z-P□□ (For F18 series) Mass 44 g [1.55 oz.]

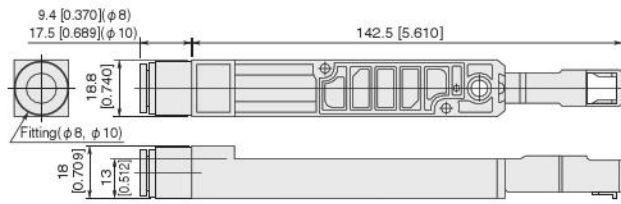

## Precautions for use of the back pressure prevention valve (F10, F15 series)

A back pressure prevention valve can be mounted on the manifold to prevent erratic operation of the cylinder due to exhaust from other valves. It is particularly effective when using a single acting cylinder or when using an exhaust center valve. Note that when a back pressure prevention valve is used, the OUT-EXH flow rate volume is reduced by as much as 30%. In addition, since the back pressure prevention valve allows back pressure leaks, be careful to avoid letting the manifold exhaust port throttle the exhaust air. When mounting the back pressure prevention valve on an existing system, observe the following points.

- ① Loosen the valve screws mounting the back pressure prevention valve, and remove the valve.
- ② For a monoblock manifold, temporarily remove the gasket between the valve and manifold, insert the back pressure prevention valve into the exhaust port, attach the gasket back in place, and then mount the valve.

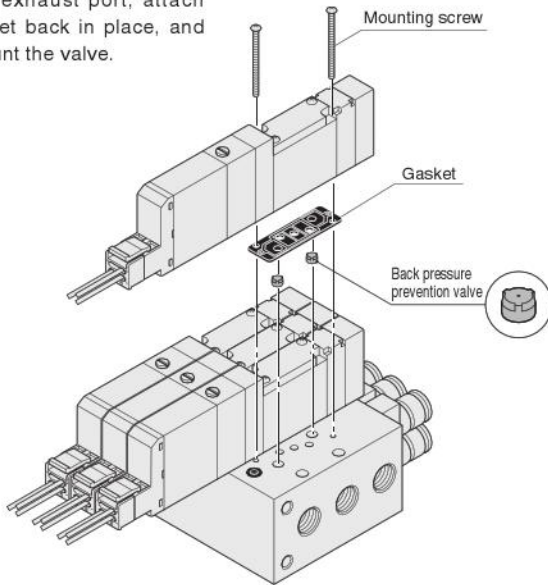

For a split type manifold, insert the back pressure prevention valve into the exhaust port, attach the dedicated gasket and plate provided, and then mount the valve.

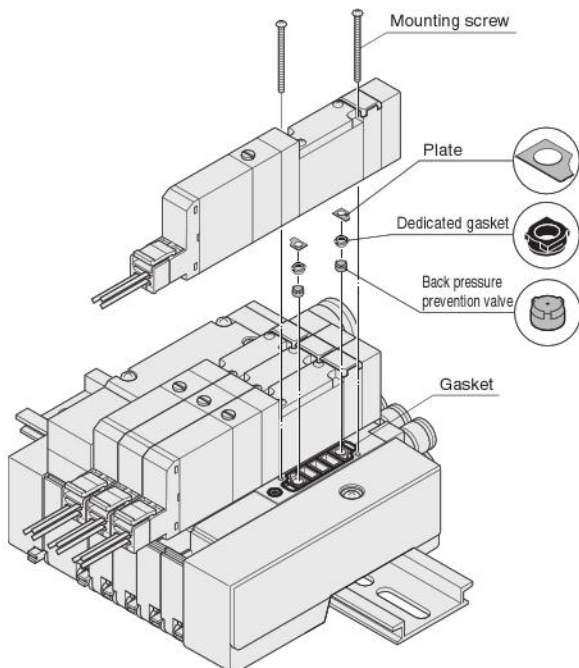

Mounting screw tightening torque: F10 series 17.6 N · cm [1.6 in·lbf]  
F15 series 49.0 N · cm [4.3 in·lbf]

## Changing the connector bracket direction (F10, F15 series)

Remove the wiring block mounting screws, position the connector bracket as shown in the illustration, and rotate the connector 90 degrees so that it faces outward. The connector can be changed to either the top surface (vertical) wiring or side surface (horizontal) wiring positions.

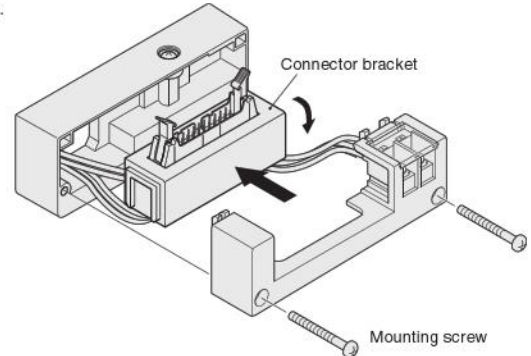

Mounting screw tightening torque: 49 N · cm [4.3 in·lbf]

## Securing the manifold in place

When securing a DIN rail mounting type manifold to the installation surface, use the number of screws table below as a guide, depending on the installation direction and with or without vibration, to secure the DIN rail in place using screws. If not secured in place, be aware that there is a possibility of air leaks or other problems occurring.

Mounting condition	Number of screws			
Horizontal mounting	2 screws or more			
Vertical mounting or vibration area	2 to 5 units	6 to 10 units	11 to 15 units	16 to 20 units
	2 screws or more	3 screws or more	4 screws or more	5 screws or more



## Fitting

### Piping

#### 1. Procedure for switching between the base piping type and the direct piping type

Base piping and direct piping can be switched by replacing the plate with a fitting block or a female thread block (see Fig. 10).

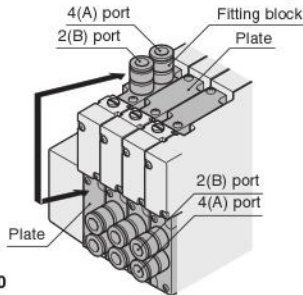

Figure 10

※ Illustration shows the F10 series.

- Cautions:**
1. Firmly tighten the screws after completing a re-combination. Recommended tightening torques are shown below.
  2. Perform piping carefully in regards to the locations of each connection port (see Figs. 11, 12).
  3. Care should be taken not to lose the gaskets while changing plates.

Series	Recommended tightening torque N · cm [in · lbf]
F10	17.6 [1.6]
F15	49.0 [4.3]
F18	49.0 [4.3]

#### ● Direct piping type

For F10, F15 series

For F18 series

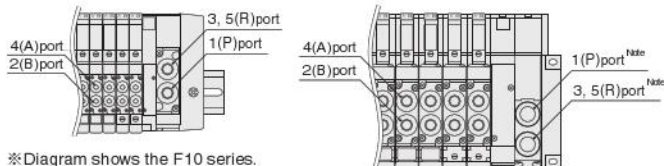

※ Diagram shows the F10 series.

Figure 11 Note: Caution should be exercised that the positions of the 1(P) and 3, 5(R) ports are reversed from their positions in the F10 and F15 series.

#### ● Base piping type

Port locations for F10, F15, F18 series are as shown in Fig. 12.

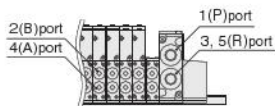

Figure 12

※ Diagram shows the F10 series.

#### 2. Attaching fittings to female thread blocks

When attaching fittings to female thread blocks, secure with the tightening torques shown below or less.

Screw size	Tightening torque N · cm [in · lbf]
Rc 1/8, NPT1/8	686 [60.7]
Rc 1/4, NPT1/4	882 [78.1]

※ For M5 and -10-32UNF, tighten at the recommended torques for the fittings used.

#### 3. Attaching fittings to piping blocks (F18Z(G)-PM(P))

To attach fittings to the female thread type piping block of the F18 series, remove the piping block portion (the triangular-shaped block portion), screw the fittings into the 1(P) and 3, 5(R) ports while holding the piping block by applying a wrench to its metal portion. The tightening torque for the mounting (two M3 screws) of the piping block after the fittings have been attached should be 49.0 N · cm [4.3 in · lbf].

### Dual use fittings (With dual use fitting blocks)

The F series dual use fitting blocks employ dual use fittings for different tube sizes, which can connect tubes of 2 different outer diameters.

#### ● Attaching and removing tubes

When connecting tubes, insert an appropriate size tube until it contacts the tube stopper, and then lightly pull it to check the connection.

For tube removal, push the tube against the tube stopper, then for large tube sizes, push on the release ring and at the same time pull the tube out. For small tube sizes, push on the outer ring by pressing the release ring and simultaneously pull the tube out (see Fig. 13).

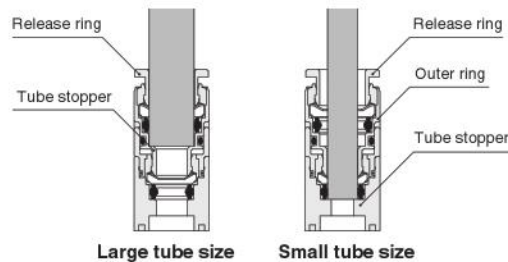

Figure 13

### Usable tubes

Either a nylon or urethane tube can be used.

Use tubes with an outer diameter tolerance within  $\pm 0.1$  mm [0.004 in.] of the nominal diameter, and ensure the ovalness (difference between the large diameter and small diameter) is 0.2 mm [0.008 in.] or less. (Using a Koganei tube is recommended.)

- Cautions:**
1. Do not use extra-soft tubes since their pull-out strength is significantly reduced.
  2. Only use tubes without scratches on their outer surfaces. If a scratch occurs during repeated use, cut off the scratched portion.
  3. Do not bend the tube excessively near the fittings. The minimum bending radii for nylon tubes are shown in the table below.
  4. When attaching or removing tubes, always stop the air supply. In addition, always confirm that air has been completely exhausted from the manifold.

Tube size	Minimum bending radius mm [in.]
$\phi 4$	20 [0.8]
$\phi 6$	30 [1.2]
$\phi 8$	50 [2.0]
$\phi 10$	80 [3.1]

# F10 and F15 Series Disassembly Diagram of Split Manifold Non-Plug-in Type

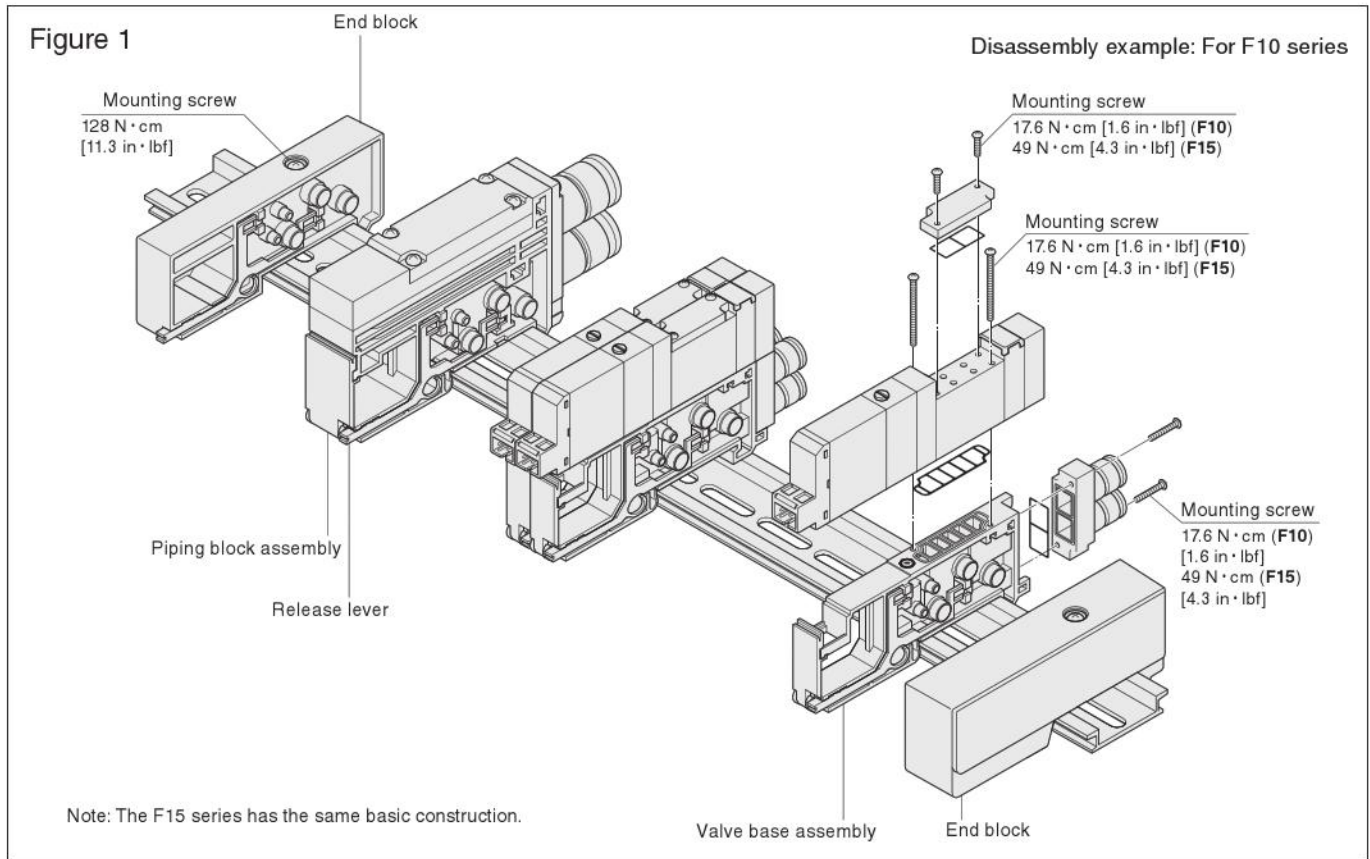

## Manifold Unit Adding Procedure (F10 and F15 Series Non-Plug-in Type)

### ■ Adding a valve base unit

Use the valve base assembly for adding valve base units.

- ① Loosen the mounting screw on the end block until it can slide (see Fig. 1).  
Note: For the F15 series, loosen the mounting screws on both the left and right end blocks (2 screws each).
- ② Press the release lever on the valve base assembly where the new unit is to be added, and disconnect the link between the bases.
- ③ Mount the valve base assembly to be added on the DIN rail as shown in Fig. 2.
- ④ Return the release lever of the valve base assembly disassembled in step ② to its normal position, as shown in Fig. 3. In addition, set the release lever for the valve assembly being added to the same position, then press the bases together until they connect and click into place.
- ⑤ Press the bases together from both sides to ensure that there is no gap between them, and then tighten the end block mounting screws, and install the units in place on the DIN rail (see Fig. 5).  
Tightening torque: 128 N·cm [11.3 in·lbf]  
Notes: 1. Always follow the steps shown in Fig. 4 when tightening the end block mounting screws for the F15 series.  
2. Confirm that the DIN rail mounting hooks secure the DIN rail (see Fig. 5).

### [Caution]

- Always cut off the power and air supply before working. In addition, always confirm that air has been completely exhausted from the manifold.
- Care should be exercised to prevent the gasket from becoming caught or lost.
- Before supplying air to the manifold, always confirm that the bases are connected, the end block mounting screws are tightened, etc. Supplying air when either of the end blocks is not secured to the DIN rail could result in air leaks or in separation of manifold bases.
- When there are a large number of valves simultaneously delivering air to the secondary side, or when there are a large number of valves overall, we recommend using 2 air supplies and exhausts (on each side).

Adding units to the piping block assembly should be performed in the same way as adding units of the valve base assembly.

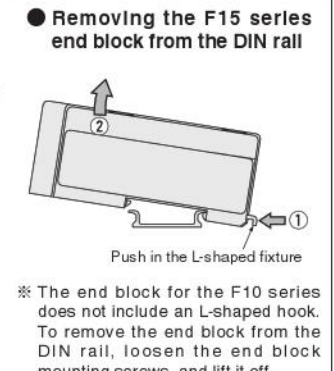
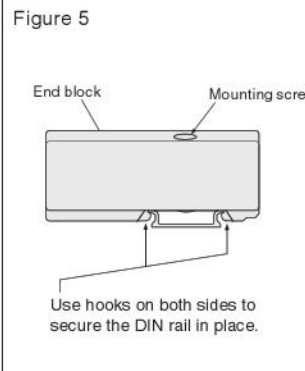
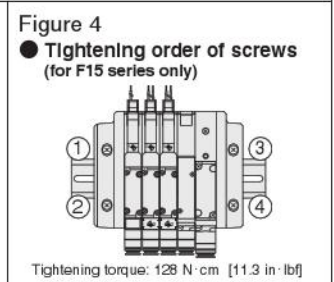
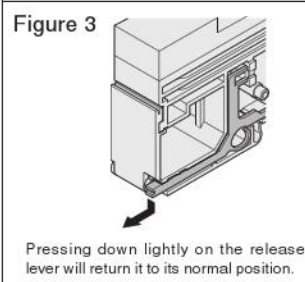
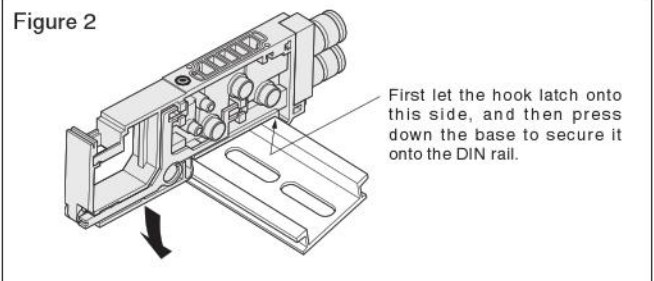

## F18 Series Disassembly Diagram of Split Manifold Non-Plug-in Type

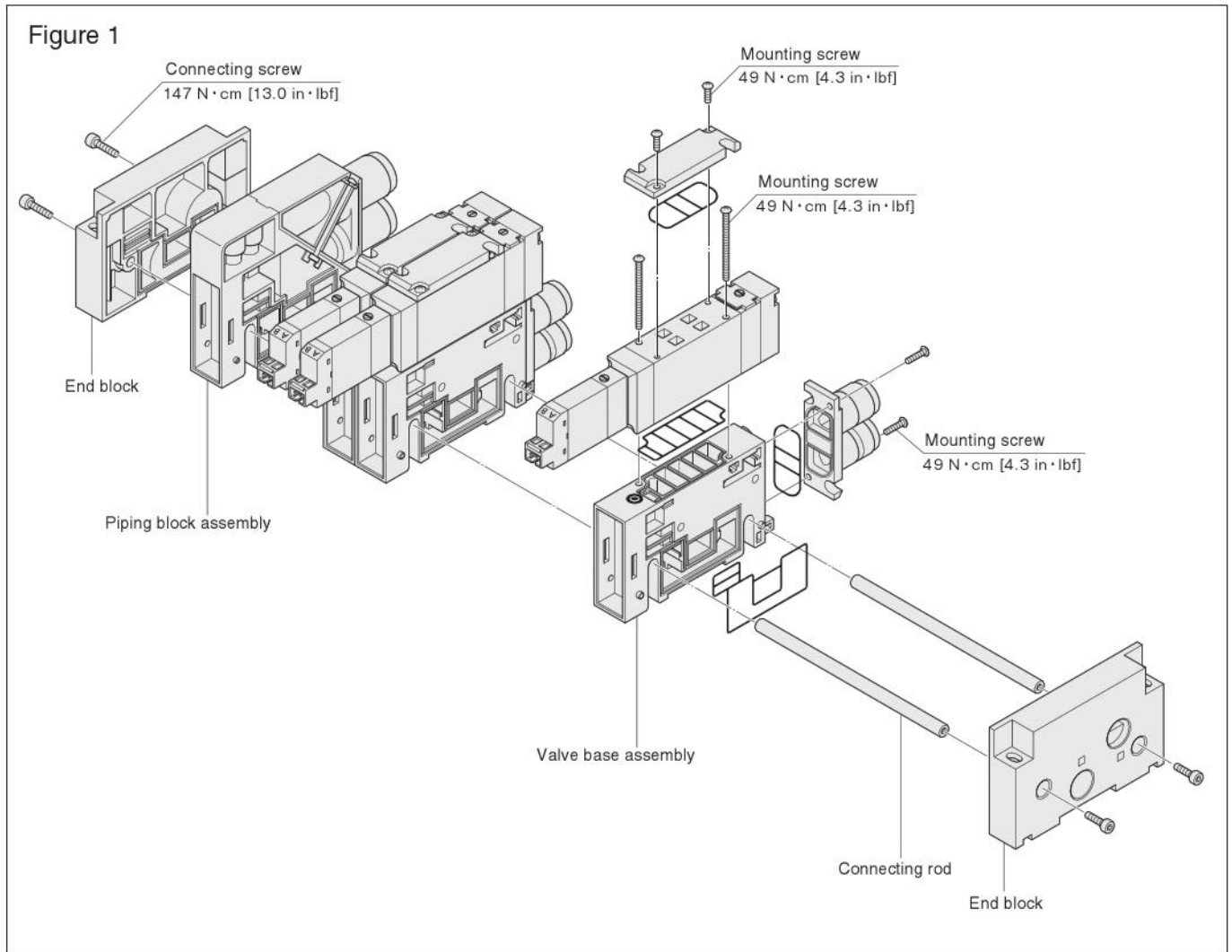

### Manifold Unit Adding Procedure (F18 Series Non-Plug-in Type)

#### ■ Adding a valve base unit

Use the valve base assembly and unit-adding connecting rod to add valve base units.

- ① Remove the connecting screws on the end block and separate the end block from the manifold (see Fig. 1).
- ② Install the connecting rods to be added, open up the spaces where the units are being added, position the gaskets onto the valve base assemblies being added, and fit the units on the connecting rods from above. At this time, securely mount the units so that no gap is left between the added valve base assemblies and the upper surface of the connecting rods.
- ③ Install gaskets onto the end blocks removed in step ①, and retighten the connecting screws. At this time, use a hexagon bar wrench to hold the connecting screws on the opposite side in place so as to prevent the screws from slipping while securing them into place. Tightening torque: 147 N·cm [13.0 in·lbf]

#### 【Caution】

- Always cut off power and air supply before working. In addition, always confirm that air has been completely exhausted from the manifold.
- Care should be exercised to prevent the gasket from becoming caught or lost.
- Before supplying air to the manifold, always confirm that the bases are securely connected, the end block connecting screws on both sides are tightened, etc. Supplying air when either of the end blocks is not secured to the DIN rail could result in air leaks or in separation of manifold bases.
- When there are a large number of valves simultaneously delivering air to the secondary side, or when there are a large number of valves overall, we recommend using 2 air supplies and exhausts (on each side).

Adding units to the piping block assembly should be performed in the same way as adding units to the valve base assembly.

# F10 and F15 Series Disassembly Diagram of Split Manifold Plug-in Type

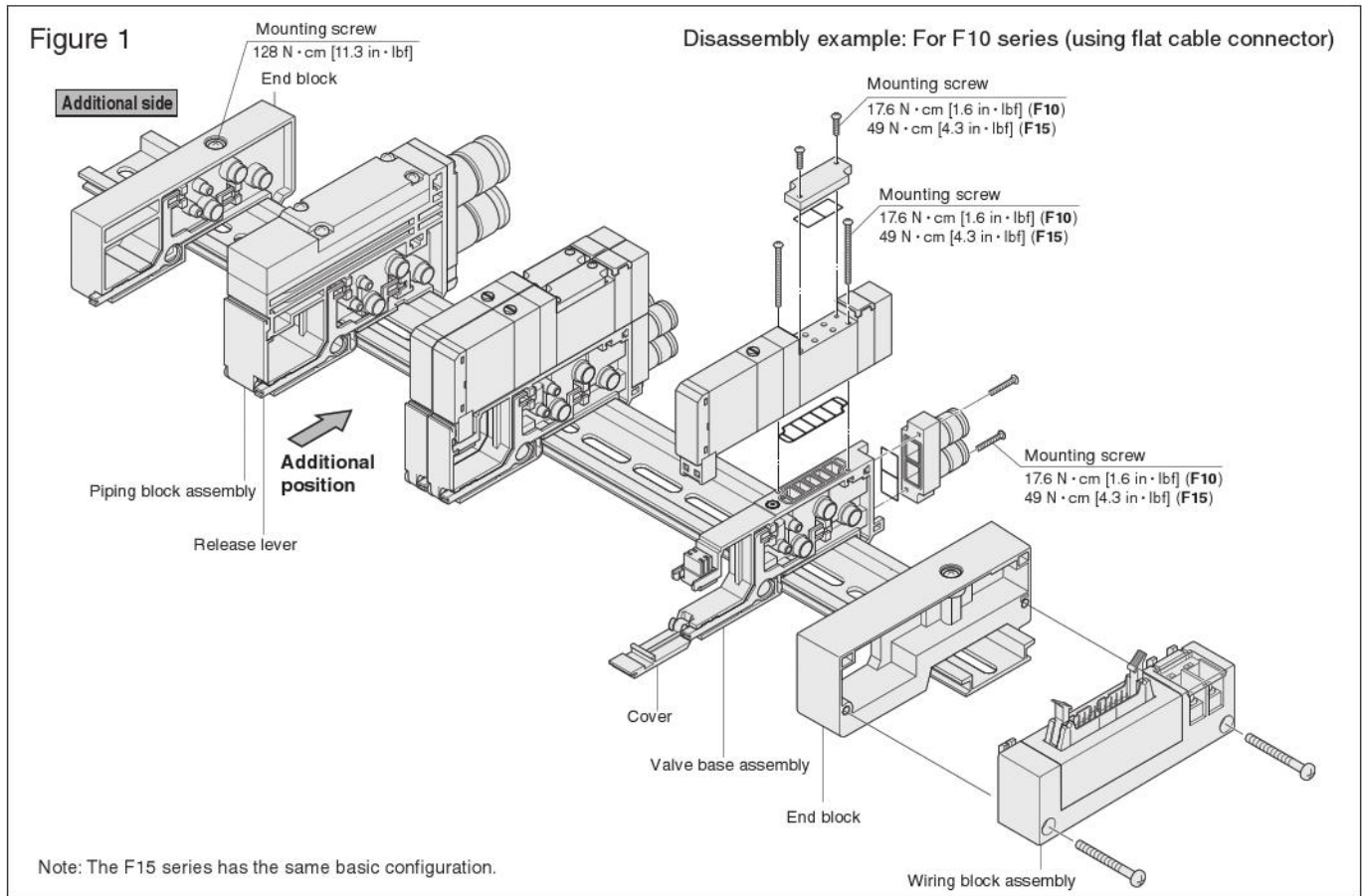

## Manifold Unit Adding Procedure (F10 and F15 Series Plug-in Type)

### ■ Adding a valve base unit

Use the valve base assembly for adding valve base units.

- Loosen the mounting screw on the end block until it can slide (see Fig. 1).

Note: For the F15 series, loosen the mounting screws on both the left and right end blocks (2 screws each).

- Add units on the additional side (with the solenoid on top and its right) shown in Fig. 1. To split up at additional unit locations, push the piping base assembly's release lever, and release the connections between the bases.
- Mount the valve base assembly to be added on the DIN rail as shown in Fig. 2.
- Return the release lever of the piping block assembly disassembled in step ② to its normal position, as shown in Fig. 3. Set the release levers on the additional valve bases in the same position, and press all the bases together until they click into place, while watching to ensure that the lead wires are not caught by the cover.
- Press the bases together from both sides to ensure that there is no gap between them, and then tighten the end block mounting screws, and install the units in place on the DIN rail (see Fig. 5). Tightening torque: 128 N·cm [11.3 in·lbf]

Notes: 1. Always follow the steps shown in Fig. 4 when tightening the end block mounting screws for the F15 series.

- Confirm that the DIN rail mounting hooks secure the DIN rail (see Fig. 5).

Figure 2

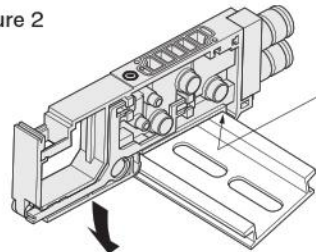

First let the hook latch onto this side, and then press down the base to secure it onto the DIN rail.

Figure 3

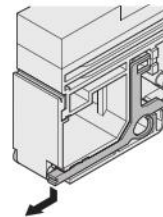

Pressing down lightly on the release lever will return it to its normal position.

Figure 4

#### ● Tightening order of screws (for F15 series only)

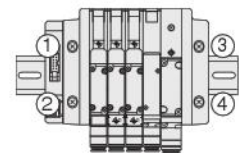

Tightening torque: 128 N·cm [11.3 in·lbf]

Figure 5

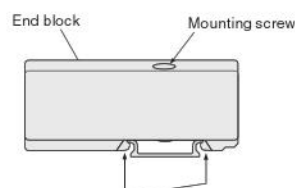

Use hooks on both sides to secure the DIN rail in place.

#### ● Removing the F15 series end block from the DIN rail

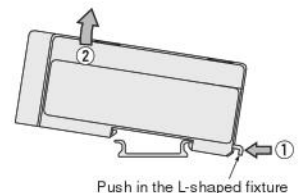

※ The end block for the F10 series does not include an L-shaped hook. To remove the end block from the DIN rail, loosen the end block mounting screws, and lift it off.

## ■ Wiring Procedure

- ① Use a flatblade screwdriver to open all of the covers (see Fig. 1). Loosen the mounting screws of the valve next to the valve base to be added, remove the valve, and remove the plug-in connector (see Fig. 6).
- ② The end terminal lead wire (short red wire) is inserted into the pin insert section (No.3) of the plug-in connector that was removed in step ① (see Fig. 7).  
(When shipping, end terminal lead wire is inserted into the plug-in connector of the end unit valve.) Remove this end terminal lead wire, and insert it into the insert section (No.3) of the plug-in connector for the valve base assembly to be added. Next, insert the common wire (red) of this plug-in connector into the insert section (No.3) of the removed plug-in connector.

Note: When inserting the lead wire, confirm that the short bar of the plug-in connector's common wire insert section has been attached.

- ③ Install each of the wired plug-in connectors in step ② to the valve base, and mount the valve.
- ④ Remove the wiring block mounting screws and place the connector bracket in the position shown in Fig. 8, then connect the lead wire (white) of the added valve base after confirming the pin locations. (For details, see the "Detailed diagram of wiring block internal connections" on p.34, 35)
- ⑤ Return the connector bracket to its original position, tighten the wiring block mounting screws in place, and then install the cover while exercising caution that the lead wires are not trapped by the cover.

## [Caution]

- Always cut off the power and air supply before working. In addition, always confirm that air has been completely exhausted from the manifold.
- When removing lead wires from the plug-in connector, use a tool with a fine tip (such as a small screwdriver) to press lightly on the contact hook from a hole on the side of the plug-in connector, and pull out the lead wire. When re-inserting the lead wire to the connector, spread the contact hooks so that they face outward, and then insert the lead wire into the plug-in connector. At this time, pull the lead wire lightly to confirm that it is securely inserted.
- Always connect the end terminal lead wires (see Fig. 7).
- Care should be exercised to prevent the gasket from becoming caught or lost.
- Before supplying air to the manifold, always confirm that the bases are connected, the end block mounting screws are tightened, etc. Supplying air when either of the end blocks is not securing the DIN rail could result in air leaks or in separation of manifold bases.
- Caution should be exercised as the number of valve units that can be added is limited in the manifold, by the wiring specifications and wiring connection types, etc. For details, see the "Table for maximum number of valve units by wiring specification," on p.66.
- When there are a large number of valves simultaneously delivering air to the secondary side, or when there are a large number of valves overall, we recommend using 2 air supplies and exhausts (on each side).

Adding units to the piping block assembly should be performed in the same way as adding units to the valve base assembly. In addition, when the wiring block and piping block are mounted side-by-side, always mount the wiring block on the outside of the piping block, for structural reasons.

Valve tightening torque		N · cm [in · lbf]
Series	Torque	
F10	17.6 [1.6]	
F15	49.0 [4.3]	

Figure 6

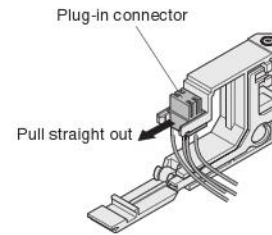
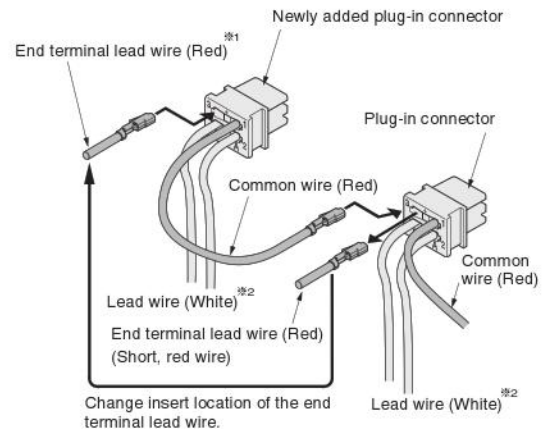
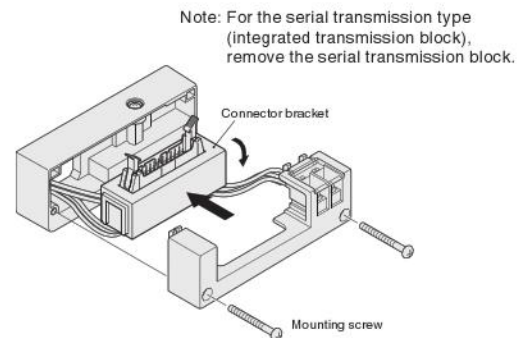

Figure 7



- ※1: Always insert end terminal lead wire.
- ※2: Shows when both A and B are used.

Figure 8



Mounting screw tightening torque: 49 N · cm [4.3 in · lbf]

See "F10, F15 Series Detailed Diagram of Wiring Block Internal Connections" on p.34, 35.

# F18 Series Disassembly Diagram of Split Manifold Plug-in Type

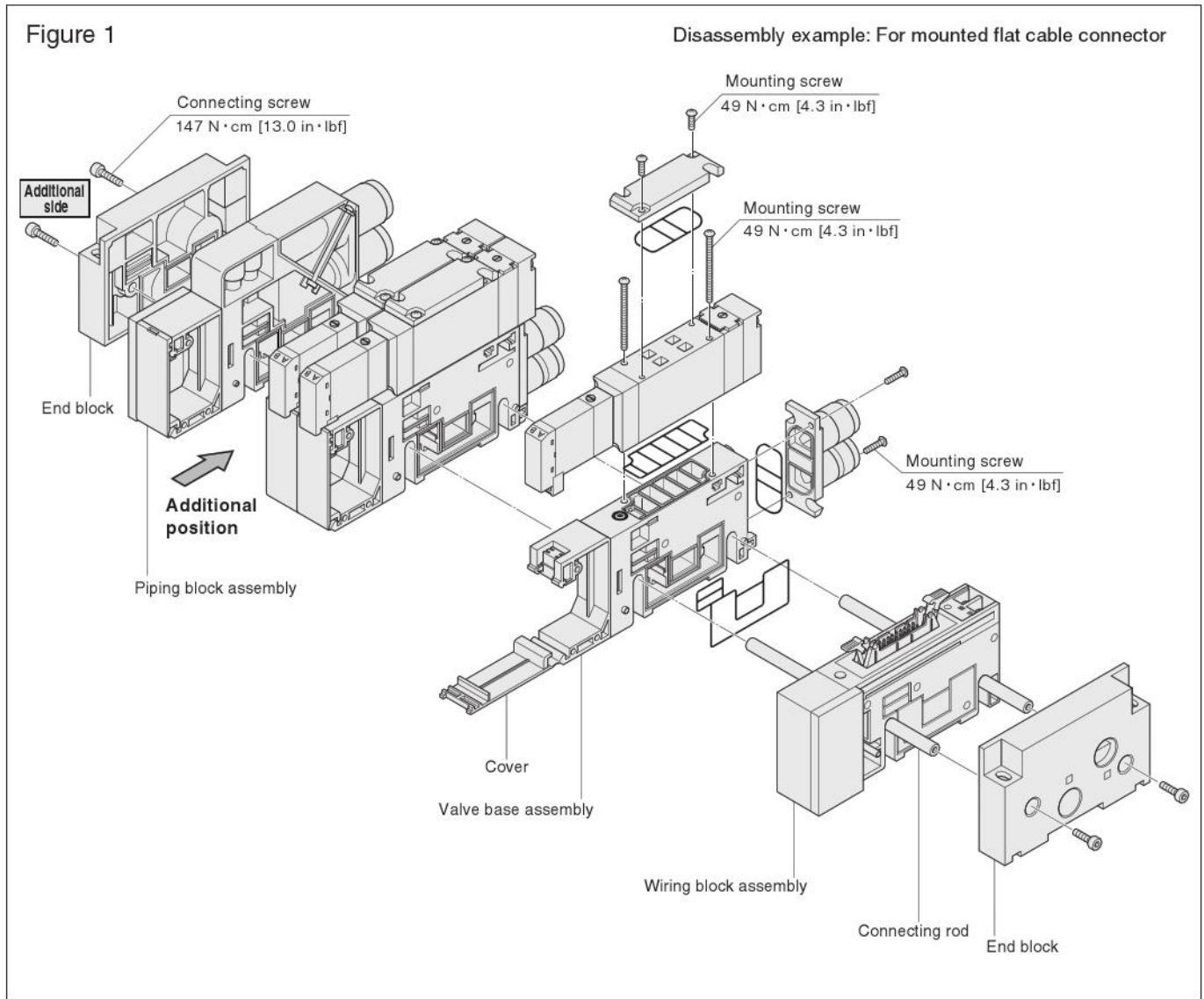

## Manifold Unit Adding Procedure (F18 Series Plug-in Type)

### ■ Adding a valve base unit

Use the valve base assembly for adding valve base units.

- ① Remove the connecting screws on the additional side end block and separate the end block from the manifold (see Fig. 1).
- ② Install the connecting rods to be added, open up spaces where the units are being added, position the gaskets onto the valve base assemblies being added, and fit the units on the connecting rods from above. At this time, securely mount the units so that no gap is left between the added valve base assemblies and the upper surface of the connecting rods.
- ③ Install gaskets onto the end blocks removed in step ①, and retighten the connecting screws. At this time, use a hexagon bar wrench to hold the connecting screws on the opposite side in place so as to prevent the screws from slipping while securing them into place. Tightening torque: 147 N·cm [13.0 in·lbf]

## ■ Wiring Procedure

- ① Use a flatblade screwdriver to open all of the covers (see Fig. 1). Loosen the mounting screws of the valve next to the valve base to be added, remove the valve, and remove the plug-in connector (see Fig. 2).
  - ② The end terminal lead wire (short red wire) is inserted into the pin insert section (No.3) of the removed plug-in connector that was removed in step ① (see Fig. 3).  
(When shipping, end terminal lead wire is inserted into the plug-in connector of the end unit valve.) Remove this end terminal lead wire, and insert it into the insert section (No.3) of the plug-in connector for the valve base assembly to be added. Next, insert the common wire (red) of this plug-in connector into the insert section (No.3) of the removed plug-in connector.
- Note: When inserting the lead wire, confirm that the short bar of the plug-in connector's common connector has been attached.
- ③ Install each of the wired plug-in connectors in step ② to the valve base, and mount the valve.
  - ④ Remove the wiring block mounting screws and place the connector bracket in the position shown in Fig. 4, then connect the lead wire (white) of the added valve base after confirming the pin locations (For details, see the "Detailed diagram of wiring block internal connections" on p.36, 37).
  - ⑤ Return the connector bracket to its original position, tighten the wiring block mounting screws in place, and then install the cover while exercising caution that the lead wires are not trapped by the cover.

## [Caution]

- Always cut off the power and air supply before working. In addition, always confirm that air has been completely exhausted from the manifold.
  - When removing lead wires from the plug-in connector, use a tool with a fine tip (such as a small screwdriver) to press lightly on the contact hook from a hole on the side of the plug-in connector, and pull out the lead wire. When re-inserting the lead wire to the connector, spread the contact hooks so that they face outward, and then insert the lead wire into the plug-in connector. At this time, pull the lead wire lightly to confirm that it is securely inserted.
  - Always connect the end terminal lead wire (see Fig. 3).
  - Care should be exercised to prevent the gasket from becoming caught or lost.
  - Before supplying air to the manifold, always confirm that the bases are connected, the end block connecting screws on both sides are tightened, etc.
- Supplying air when either of the end blocks is not securing the DIN rail could result in air leaks or in separation of manifold bases.
- Caution should be exercised as the number of valve units that can be added is limited in the manifold, by the wiring specifications and wiring connection types, etc. For details, see the "Table for maximum number of valve units by wiring specification," on p.84.
  - When there are a large number of valves simultaneously delivering air to the secondary side, or when there are a large number of valves overall, we recommend using 2 air supplies and exhausts (on each side).

Adding units to the piping block assembly should be performed in the same way as adding units to the valve base assembly. In addition, when the wiring block and piping block are mounted side-by-side, always mount the wiring block on the outside of the piping block, for structural reasons.

**Valve tightening torque** N · cm [in · lbf]

Series	torque
F18	49.0 [4.3]

Figure 2

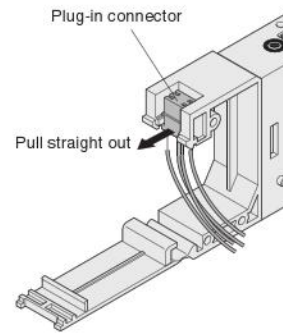
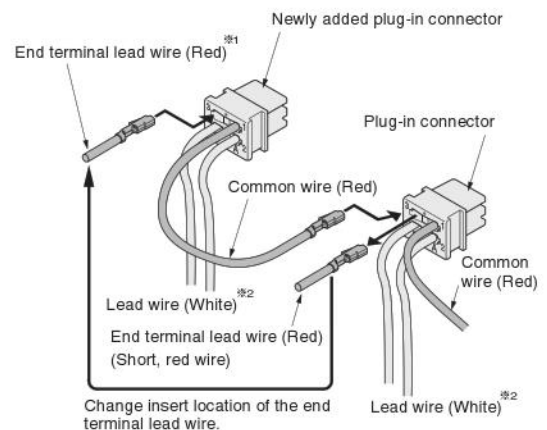
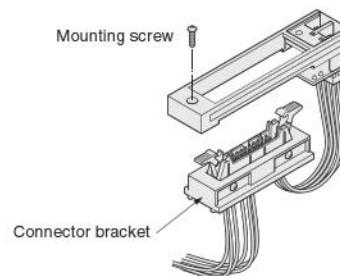

Figure 3



- ※1: Always insert end terminal lead wire.
- ※2: Shows when both A and B are used.

Figure 4



See "F18 Series Detailed Diagram of Wiring Block Internal Connections" on p.36, 37.

# F10, F15 Series Detailed Diagram of Wiring Block Internal Connections

## Flat cable connector 10, 20, 26 pins

●For -F100□□

●For -F101□□

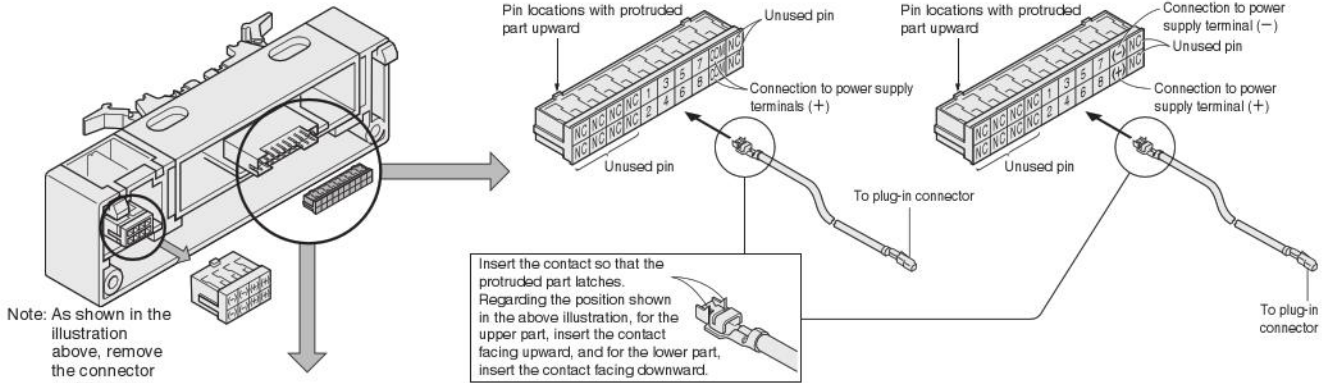

Note: As shown in the illustration above, remove the connector and then perform the wiring.

●For -F200□□

●For -F201□□

●For -F260□□

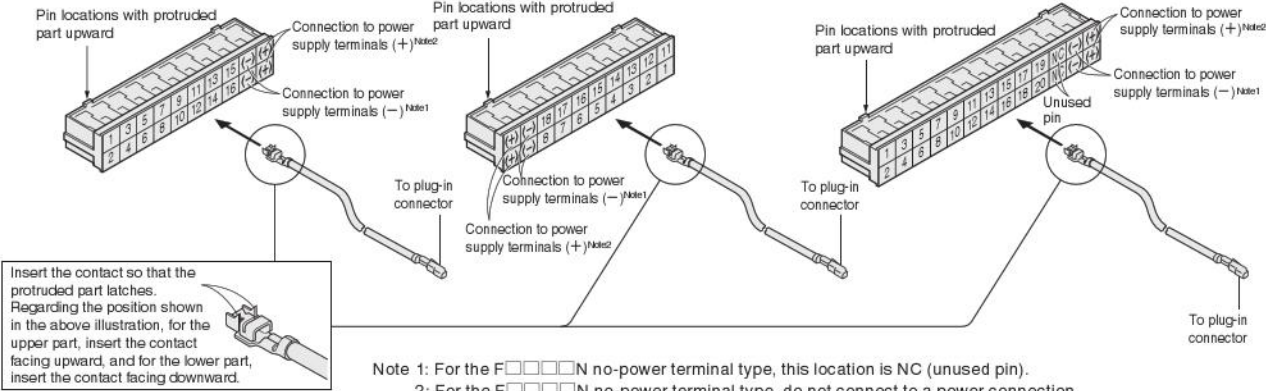

Note 1: For the F□□□□N no-power terminal type, this location is NC (unused pin).  
 Note 2: For the F□□□□N no-power terminal type, do not connect to a power connection terminal, but instead connect to the plug-in connector (+) terminal.

## D-sub connector

●For -D250□□

●For -D251□□

●For -D370NU Note

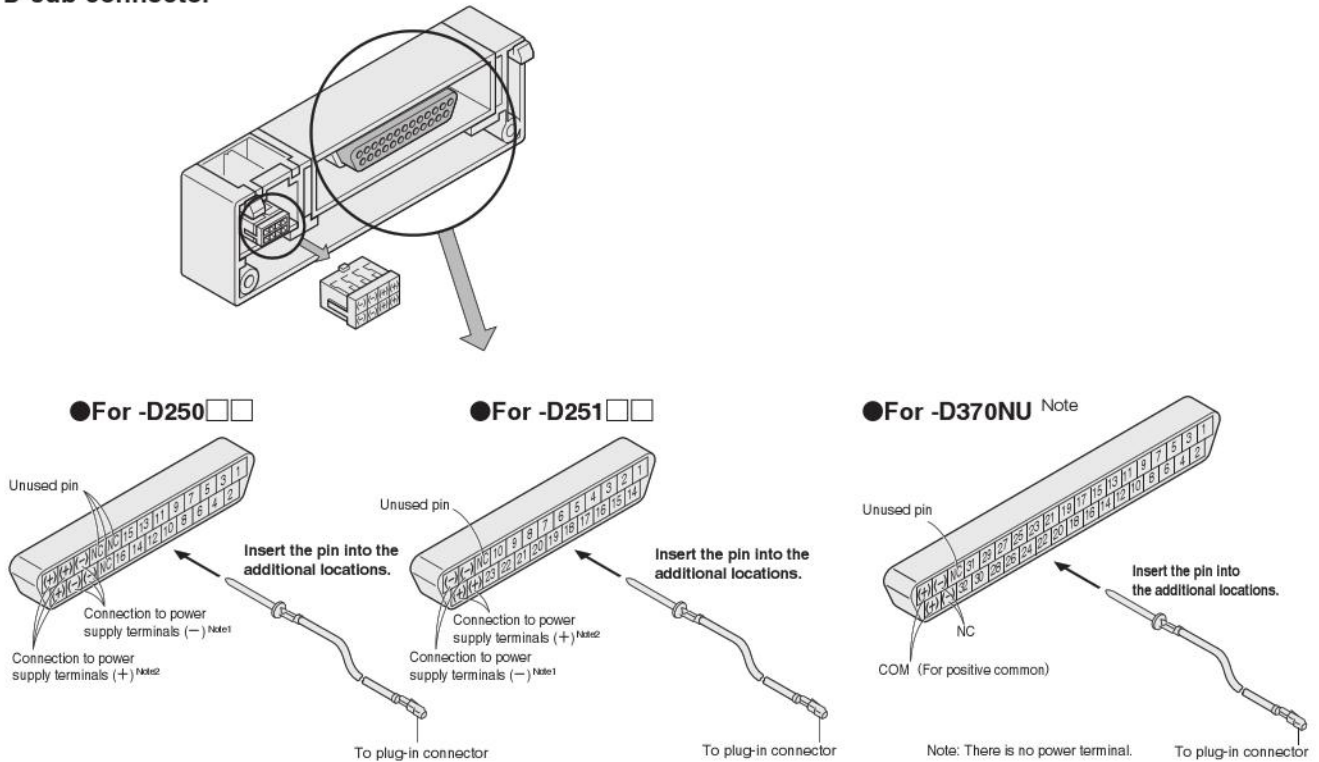

Note 1: For the D25□□N no-power terminal type, this location is NC (unused pin).  
 Note 2: For the D25□□N no-power terminal type, do not connect to a power connection terminal, but instead connect to the plug-in connector (+) terminal.

## Terminal block

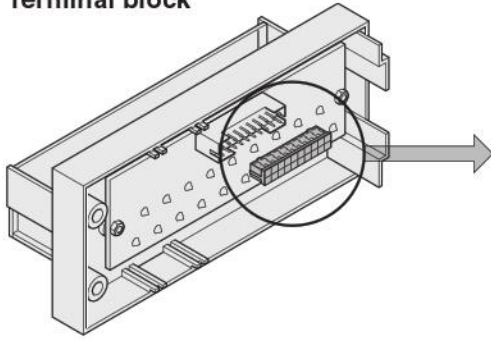

Note: As shown in the illustration above, remove the connector and then perform the wiring.

### ● For -T200

Pin locations with protruded part upward

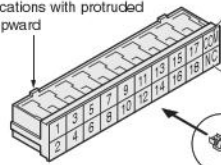

Manifold common wire

Unused pin

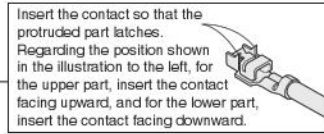

To plug-in connector

## Serial transmission block

### ● For 16 outputs

### ● For 32 outputs

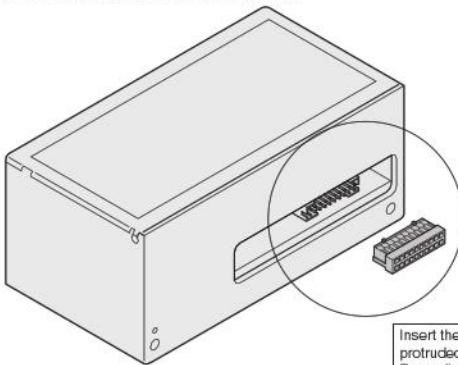

Note: As shown in the illustration above, remove the connector and then perform the wiring.

Pin locations with protruded part upward

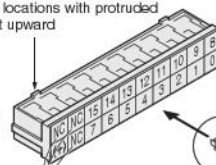

Unused pin

Pin locations with protruded part upward

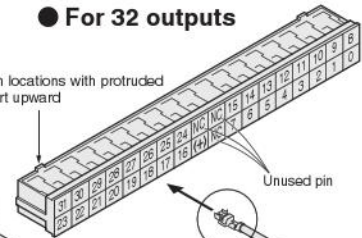

Unused pin

Insert the contact so that the protruded part latches. Regarding the position shown in the above illustration, for the upper part, insert the contact facing upward, and for the lower part, insert the contact facing downward.

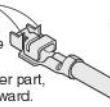

To plug-in connector

To plug-in connector

# F18 Series Detailed Diagram of Wiring Block Internal Connections

## Flat cable connector 10, 20, 26 pins

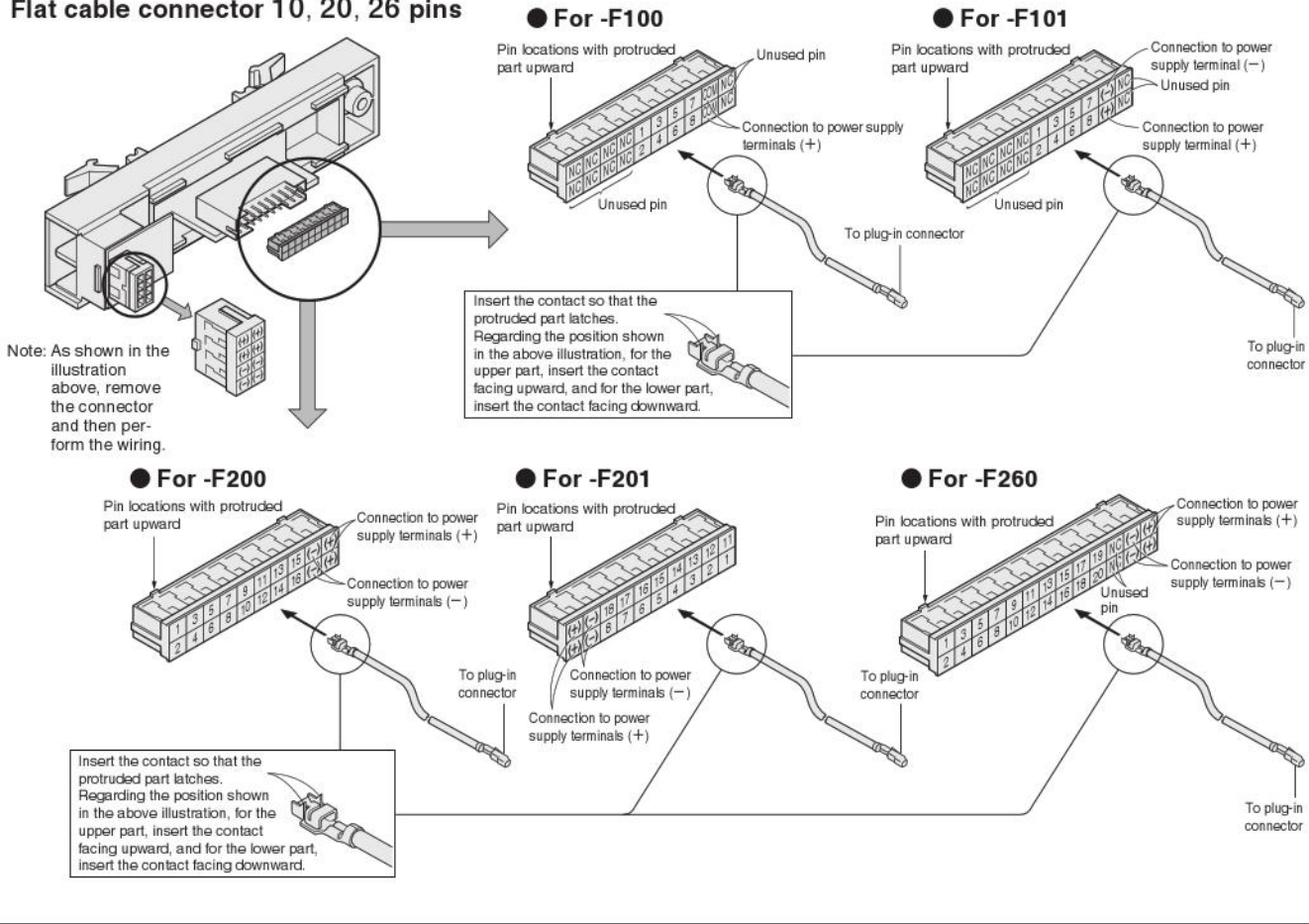

## D-sub connector

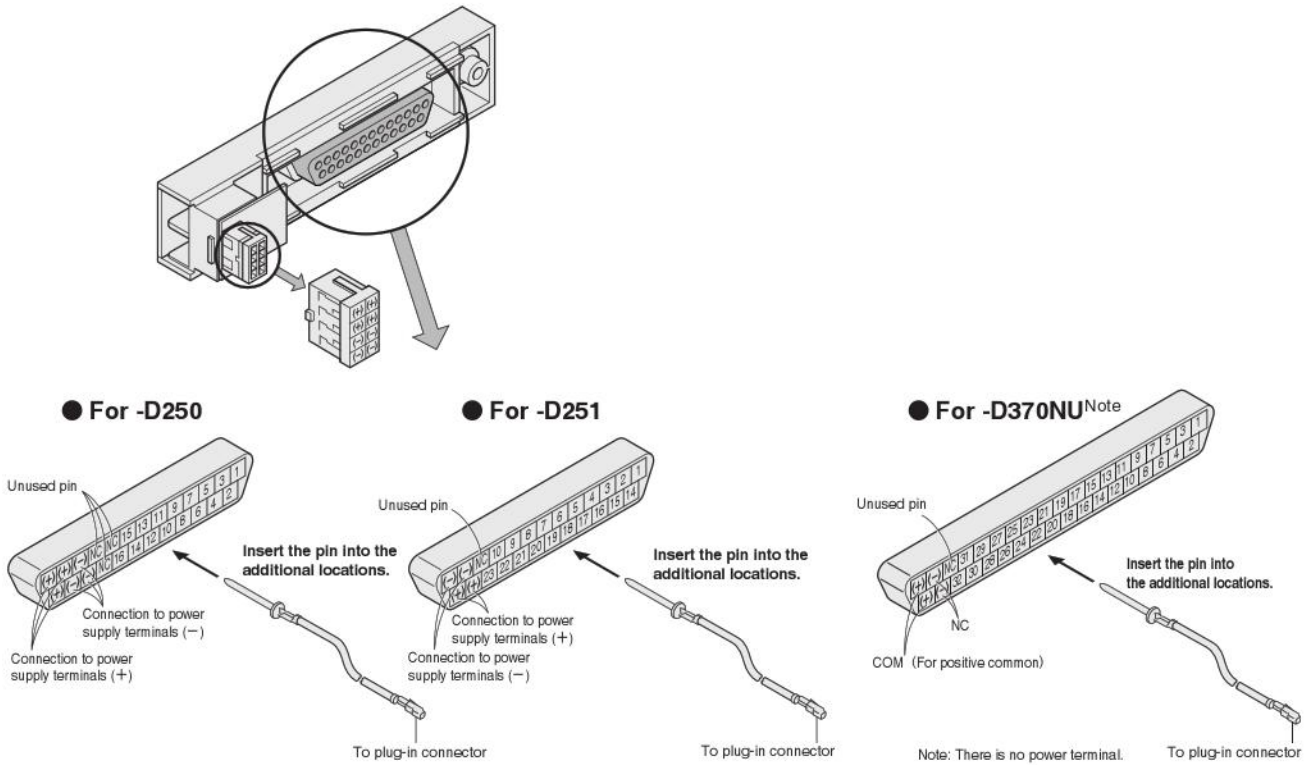

## Terminal block

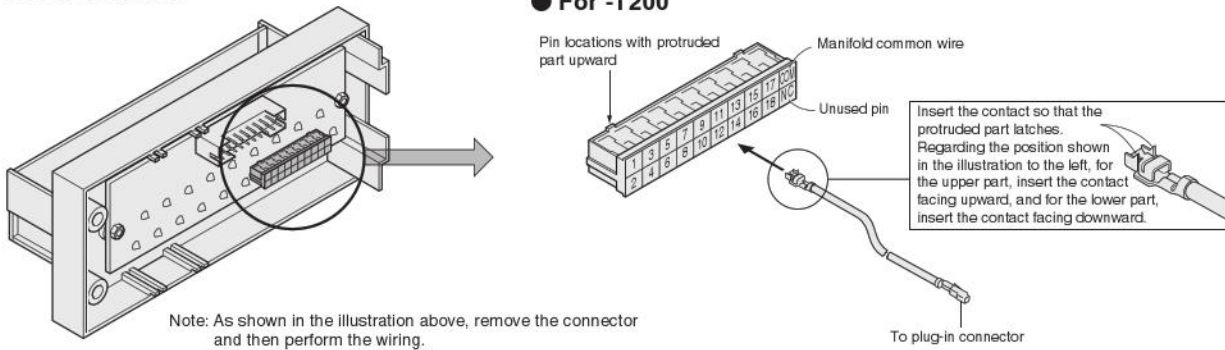

## Product Configurations for the F Series Serial Transmission Compatible Manifolds

When ordering the serial transmission compatible manifold, note that the product configurations vary between the F10 and F15 series, and the F18 series.

### ■ For F10 and F15 series

#### ● Models compatible with integrated transmission block

- For Omron CompoBus/S
- For CC-Link
- For DeviceNet
- For CompoNet
- For EtherCAT

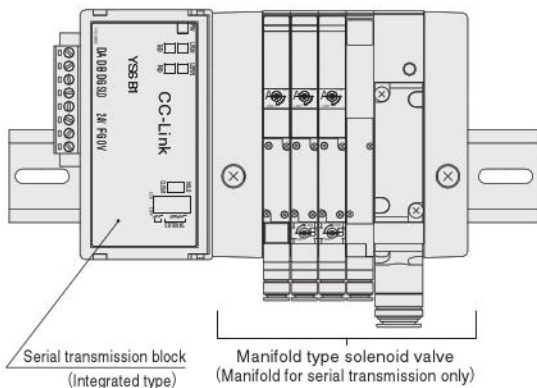

#### ● Models for stand-alone transmission block

The manifold body and serial transmission block are connected with a flat cable.

- For Omron B7A Link Terminal

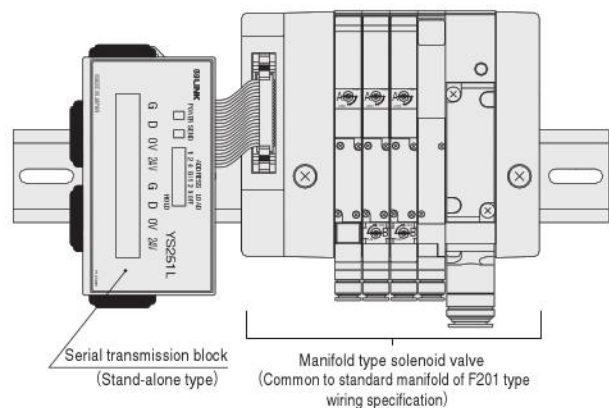

### ■ For F18 series

#### ● Models compatible with integrated transmission block

- For Omron CompoBus/S
- For CompoNet
- For CC-Link

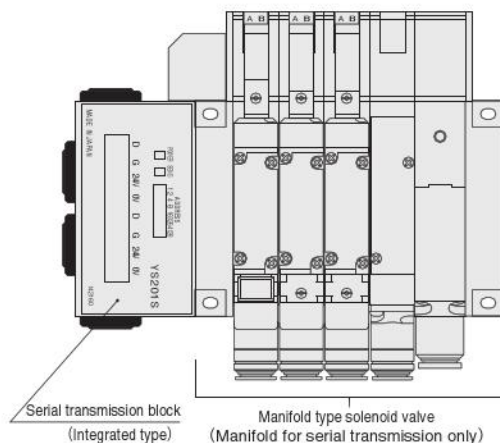

#### ● Models for stand-alone transmission block

The manifold body and serial transmission block are connected with a flat cable.

- For Omron B7A Link Terminal

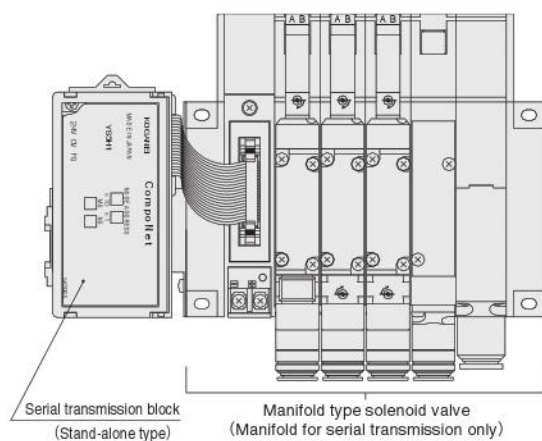

# F10, F15 Series Specifications of Serial Transmission Compatible Manifolds

## General Specifications

Voltage	24VDC ±10%
Operating temperature range	5~50°C [41~122°F]
Vibration resistance	49.0 m/s <sup>2</sup> [5G]
Shock resistance	98.1 m/s <sup>2</sup> [10G]

● For details about specifications, see each user's manual (see below).

## F10, F15 Series Serial Transmission Block, Terminal Block (LED) Part Names

### ● For OMRON B7A Link Terminal

Transmission block specification: -31 (standard type), -32 (high-speed type)

Output selecting switch in faulty operation

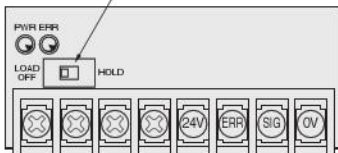

#### LED indicator

Indicator	Description
PWR	•Lights up when power is turned on
ERR	•Lights up during faulty transmission

#### Remarks

##### ● Connection method: 1 to 1

(Transmission block spec.)	Standard type (-31)	High-speed type (-32)
Transmission delay time	Max. 31 ms	Max. 5 ms
Transmission distance	Max. 500 m [1640 ft]	Max. 100 m [328 ft]

※For details of B7A Link Terminal, see the OMRON catalog, user's manual, etc.

##### ● Number of outputs per block

Maximum of 16 solenoids  
 Output type: NPN open collector  
 Rated load voltage: 24VDC  
 Output current: Sink current MAX. 40 mA

● Related materials: User's manual, document No. BK-HV038

### ● For CC-Link

Transmission block specification: -B3 (32 outputs)

Transmission speed setting switch Station number setting switches

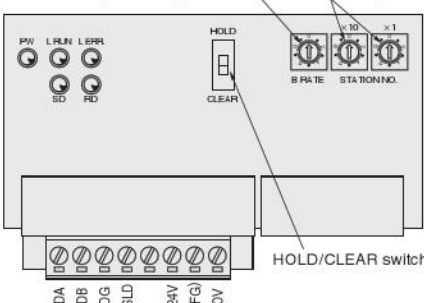

#### LED indicator

Indicator	Description
PW	•Lights up when power is turned on
L RUN	•Lights up when normal data is received from master station
SD	•Lights up during sending data
RD	•Lights up during receiving data
L ERR.	•Lights up during transmission errors, and shuts off when time is over Lights up due to station number setting error or transmission speed setting error

#### Remarks

※Conforms to CC-Link.

##### ● Number of outputs per block

32 solenoids (transmission block specification: -B3)

※Since the block occupies 1 station, if remote I/O stations are entirely composed of the blocks, a maximum of 64 units can be connected to 1 master station.

● Related materials: User's manual, document No.BK-HV041

### ● For OMRON CompoBus/S

Transmission block specification: -A1 (16 outputs)

Dip switches for various settings

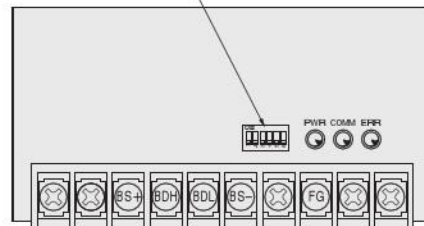

#### LED indicator

Indicator	State	Color	Description
PWR	Lights up	Green	•During power supply
	Shuts off		•Power not supplied
COMM	Lights up	Yellow	•During normal communication
	Shuts off		•Communication fault, or standby
ERR	Lights up	Red	•Communication fault occurred
	Shuts off		•During normal communication, or standby

#### Remarks

※For details of CompoBus/S, see the OMRON catalog, user's manual, etc.

##### ● Number of outputs per block

16 solenoids (transmission block specification: -A1)

● Related materials: User's manual, document No.BK-HV040

### ● For DeviceNet

Transmission block specification: -D1 (16 outputs), -D3 (32 outputs)

Dip switches for various settings

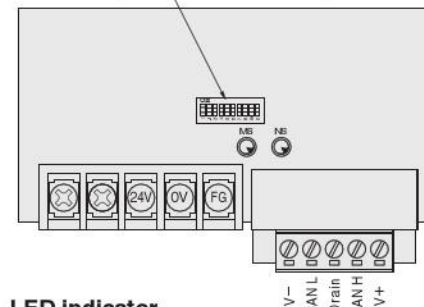

#### LED indicator

Indicator	State	Color	Description
MS	Lights up	Green	• Normal state
	Flashing		• No setting state
	Lights up	Red	• Serious breakdown
	Flashing		• Minor breakdown
NS	Shuts off	—	• No power supply
	Lights up	Green	• Communication connection completed
	Flashing		• No communication connection
	Lights up	Red	• Serious communication fault
Flashing	• Minor communication fault		
Shuts off	—	• No power supply	

#### Remarks

※Conforms to DeviceNet.

##### ● Number of outputs per block

A maximum of 16 solenoids (transmission block specification: -D1)  
 A maximum of 32 solenoids (transmission block specification: -D3)

● Related materials: User's manual, document No. BK-HV042

### ● For CC-Link

Transmission block specification: -B1 (16 outputs)

Dip switches for various settings

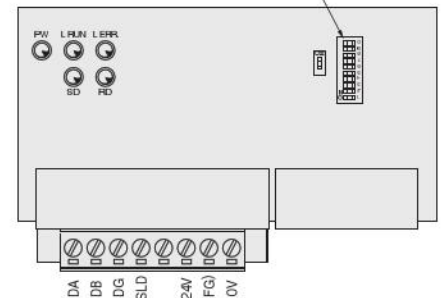

#### LED indicator

Indicator	Description
PW	•Lights up when power is turned on
L RUN	•Lights up when normal data is received from master station
SD	•Lights up during sending data
RD	•Lights up during receiving data
L ERR.	•Lights up during transmission errors, and shuts off when time is over Lights up due to station number setting error or transmission speed setting error

#### Remarks

※Conforms to CC-Link.

##### ● Number of outputs per block

16 solenoids (transmission block specification: -B1)

※Since the block occupies 1 station, if remote I/O stations are entirely composed of the blocks, a maximum of 64 units can be connected to 1 master station.

● Related materials: User's manual, document No.BK-HV041

### ● For CompoNet

Transmission block specification: -H1 (16 outputs)

Node address setting switches

From left ×10, ×1

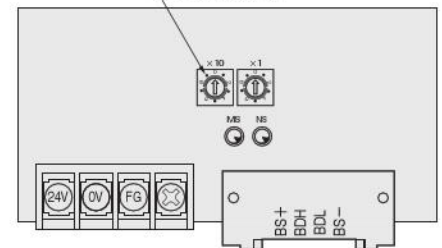

#### LED indicator

Indicator	State	Color	Description
MS	Lights up	Green	• Normal state
	Lights up	Red	• Serious breakdown
	Flashing	Red	• Minor breakdown
	Shuts off	—	• Power OFF/In preparation
NS	Lights up	Green	• Online/Access state
	Flashing	Green	• Online/No-access state
	Lights up	Red	• Serious communication fault
	Flashing	Red	• Minor communication fault
Shuts off	—	• Power OFF/In preparation	

#### Remarks

※Conforms to CompoNet.

##### ● Number of outputs per block

16 solenoids (transmission block specification: -H1)

● Related materials: User's manual, document No.BK-HV043  
 ※The communication connector is sold by Omron Corporation. Direct your inquiries to Omron.

# F10, F15 Series Serial Transmission Block, Terminal Block (LED) Part Names

## ●EtherCAT Compliant

Transmission block specifications: -K1 (16 outputs), -K3 (32 outputs)

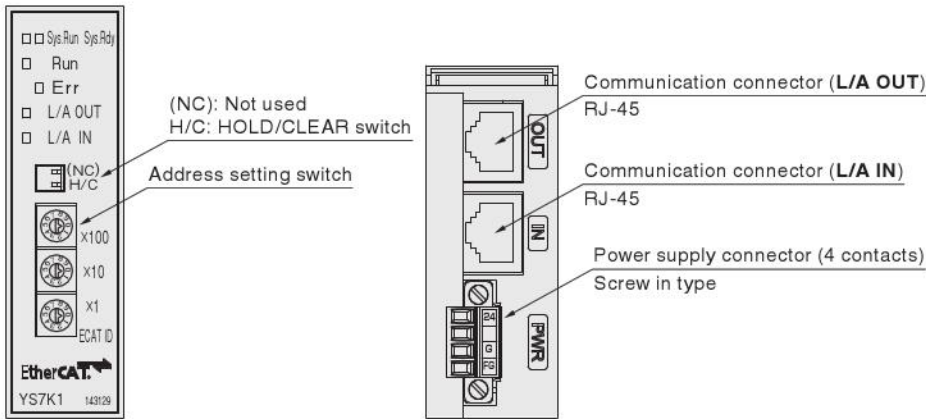

### LED indicator

Indicator	State	Color	Description
Sys.Run/Sys.Rdy	Lit/Not lit	Green/yellow	• Transmission block operation normal
	Flashing/flashing	Green/yellow	• Transmission block initialization
	Not lit/lit or flashing	Green/yellow	• Transmission block error
	Not lit/Not lit	Green/yellow	• Transmission block power OFF
Run	Off	Green	• INIT
	Flashing (blinking)	Green	• PRE-OPERATIONAL
	Flashing (single flash)	Green	• SAFE-OPERATIONAL
	Lighted	Green	• OPERATIONAL
Err	Off	Red	• No error
	Flashing (blinking)	Red	• Invalid setting
	Flashing (single flash)	Red	• Unrequested change in status
	Flashing (double flash)	Red	• Communication disconnect
L/A OUT L/A IN	Lighted	Green	• Normal communication
	Flashing	Green	• EtherCAT frame sending/receiving
	Off	Green	• Not connected

### Remarks

\*EtherCAT compliant.

### ●Number of outputs for this block

Number of solenoids for -K1 is 16 and for -K3 is 32.

### ●F10 and F15 series are supported

### Remarks

※EtherCAT® is a registered trademark for patented technology licensed from Beckhoff Automation GmbH of Germany.

●See the separate user's manual No. BK-HV044 for details about specifications and handling.

●We recommend category 5 (100BASE-TX) or higher twisted paired cables (CAT 5e STP) for communication cables.

●You can download the ESI (EtherCAT Slave Information) file from our web site.

## ●EtherNet/IP Compliant

Transmission block specifications: -M1 (16 outputs), -M3 (32 outputs)

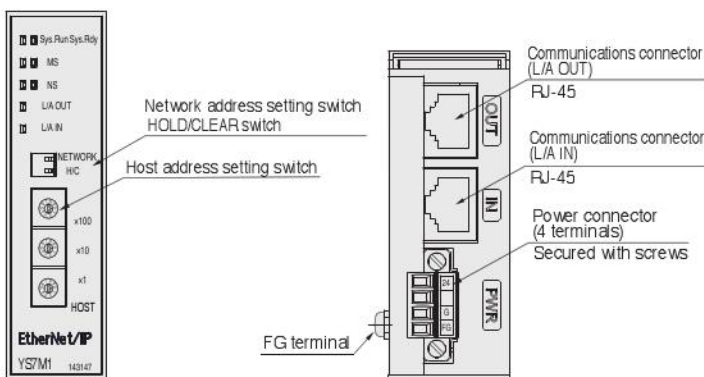

### Names of LEDs

Indicator	LED State	Description
Sys.Run/Sys.Rdy	<input type="checkbox"/> off/off	Transmission block power off
	<input checked="" type="checkbox"/> Lit green/off	Transmission block normal operation
MS	<input type="checkbox"/> Off	Transmission block power off
	<input checked="" type="checkbox"/> Flashing green	IP address setting in progress
	<input checked="" type="checkbox"/> Lit green	Normal operation
	<input checked="" type="checkbox"/> Flashing red	Recoverable errors
NS	<input checked="" type="checkbox"/> Lit red	Unrecoverable error
	<input type="checkbox"/> Off	Transmission block power off
	<input checked="" type="checkbox"/> Flashing green	Transmission block is online without an established connection
	<input checked="" type="checkbox"/> Lit green	Transmission block is online and has established connections
L/A	<input checked="" type="checkbox"/> Flashing red	Connection timeout
	<input checked="" type="checkbox"/> Lit red	Transmission block detected a duplicate IP address
	<input type="checkbox"/> Off	Not connected
	<input checked="" type="checkbox"/> Lit green	Normal communication

EtherNet/IP™ is a trademark of ODVA.

### Remarks

\*EtherNet/IP compliant.

### ●Number of outputs for this block

Number of solenoids for -M1 is 16 and for -M3 is 32.

### ●F10 and F15 series are supported

●See the separate user's manual No. BK-HV045 for details about specifications and handling.

●We recommend (CAT 5e STP) shielded twisted pair cables that are at least category 5 (100BASE-TX) for communication cables.

●The EDS (electronic data sheet) files can be downloaded from our homepage.

■For specifications and handling details, see the above-listed user's manuals (Document No. BK-HV038, BK-HV040 - BK-HV045).

# F18 Series Specifications of Serial Transmission Compatible Manifolds

## General Specifications

Voltage	24VDC ±10%
Operating temperature range	5~50°C [41~122°F]
Vibration resistance	49.0 m/s <sup>2</sup> [5G]
Shock resistance	98.1 m/s <sup>2</sup> [10G]

● For details about specifications, see each user's manual (see below).

## F18 Series Serial Transmission Block, Terminal Block (LED) Part Names

### ● For OMRON B7A Link Terminal

Transmission block specification: -31 (standard type), -32 (high-speed type)

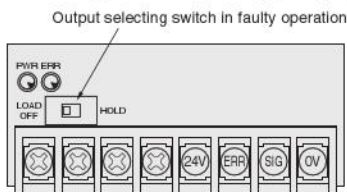

#### LED indicator

Indicator	Description
PWR	•Lights up when power is turned on
ERR	•Lights up during faulty transmission

#### Remarks

##### ● Connection method: 1 to 1

(Transmission block spec.)	Standard type (-31)	High-speed type (-32)
Transmission delay time	Max. 31 ms	Max. 5 ms
Transmission distance	Max. 500 m [1640 ft.]	Max. 100 m [328 ft.]

※For details of B7A Link Terminal, see the OMRON catalog, user's manual, etc.

##### ● Number of outputs per block

Maximum of 16 solenoids

##### ● Error output specifications

Output type: NPN open collector

Rated load voltage: 24VDC

Output current: Sink current MAX. 40 mA

##### ● Related materials: User's manual, document No. BK-HV038

### ● For CompoNet

Transmission block specification: -H1 (16 outputs)

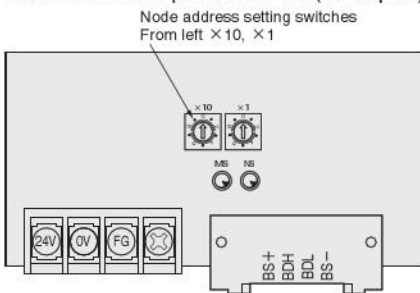

#### LED indicator

Indicator	State	Color	Description
MS	Lights up	Green	• Normal state
	Lights up	Red	• Serious breakdown
	Flashing	Red	• Minor breakdown
	Shuts off	—	• Power OFF/In preparation
NS	Lights up	Green	• Online/Access state
	Flashing	Green	• Online/No-access state
	Lights up	Red	• Serious communication fault
	Flashing	Red	• Minor communication fault
	Shuts off	—	• Power OFF/In preparation

#### Remarks

※ Conforms to CompoNet.

##### ● Number of outputs per block

16 solenoids (transmission block specification: -H1)

##### ● Related materials: User's manual, document No. BK-HV043

※ The communication connector is sold by Omron Corporation. Direct your inquiries to Omron.

■ For specifications and handling details, see the above-listed user's manuals (Document No. BK-HV038, BK-HV040, BK-HV041, BK-HV043).

### ● For OMRON CompoBus/S

Transmission block specification: -A1 (16 outputs)

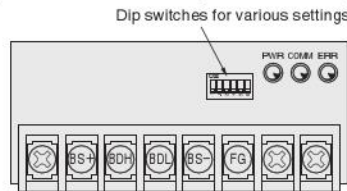

#### LED indicator

Indicator	State	Color	Description
PWR	Lights up	Green	• During power supply
	Shuts off		• Power not supplied
COMM	Lights up	Yellow	• During normal communication
	Shuts off		• Communication fault, or standby
ERR	Lights up	Red	• Communication fault occurred
	Shuts off		• During normal communication, or standby

#### Remarks

※ For details of CompoBus/S, see the OMRON catalog, user's manual, etc.

##### ● Number of outputs per block

16 solenoids (transmission block specification: -A1)

##### ● Related materials: User's manual, document No. BK-HV040

### ● For CC-Link

Transmission block specification: -B1 (16 outputs)

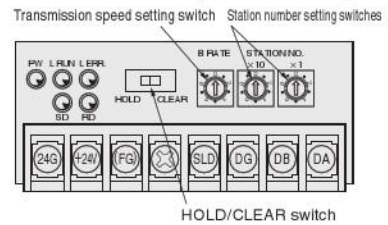

#### LED indicator

Indicator	Description
PW	• Lights up when power is turned on
L RUN	• Lights up when normal data is received from master station
SD	• Lights up during sending data
RD	• Lights up during receiving data
L ERR.	• Lights up during transmission errors, and shuts off when time is over • Lights up due to station number setting error or transmission speed setting error

#### Remarks

※ Conforms to CC-Link.

##### ● Number of outputs per block

16 solenoids (transmission block specification: -B1)

※ Since the block occupies 1 station, if remote I/O stations are entirely composed of the blocks, a maximum of 64 units can be connected to 1 master station.

##### ● Related materials: User's manual, document No. BK-HV041















# F Series Order Codes

The solenoid valves F series order codes are classified into the following 10 categories. For details on order codes, see the designated pages.

**F10 Series  
F15 Series**

**F18 Series**

<p><b>T:</b> Single valve unit</p> 	<p>p. 44</p>	<p>p. 72</p>
<p><b>M□A□:</b> Monoblock manifold A type (base piping type)</p> 	<p>p. 46</p>	<p>p. 74</p>
<p><b>M□F□:</b> Monoblock manifold F type (direct piping type)</p> 	<p>p. 48</p>	<p>p. 76</p>
<p><b>M□A□:</b> Monoblock manifold A type, wire-saving type (base piping type)</p> 	<p>p. 50</p>	
<p><b>M□F□:</b> Monoblock manifold F type, wire-saving type (direct piping type)</p> 	<p>p. 52</p>	
<p><b>M□AP:</b> PC board manifold A type (base piping type)</p> 	<p>p. 54</p>	
<p><b>M□FP:</b> PC board manifold F type (direct piping type)</p> 	<p>p. 58</p>	
<p><b>M□N□:</b> Split manifold non-plug-in type</p> 	<p>p. 60</p>	<p>p. 78</p>
<p><b>M□P□:</b> Split manifold plug-in type</p> 	<p>p. 64</p>	<p>p. 82</p>
<p><b>M□S□:</b> Serial transmission compatible manifold</p> 	<p>p. 68</p>	<p>p. 86</p>

# F10, F15 Series Single Valve Unit Order Codes

## Valve size

- F10**  
10 mm [0.394 in.] width  
Standard type
- F10L**  
10 mm [0.394 in.] width  
Low-current type
- F15**  
15 mm [0.591 in.] width  
Standard type
- F15L**  
15 mm [0.591 in.] width  
Low-current type

## Valve outlet type

- Without inlet/outlet block  
**Blank**
- With A type outlet plate  
**-A1**
- With A type sub-base  
**-A2**  
**-A2H**

- With outlet port dual use fitting block  
**-FJ**
- With outlet port single use fitting block  
**-F5**
- With outlet port female thread block  
**-F6**
- With outlet port single use fitting block  
**-FJ6**

- With outlet port female thread block  
With inlet port female thread block  
**-F4**  
**-F4H**
- With outlet port single use fitting block  
With inlet port female thread block  
**-F5**
- With outlet port single use fitting block  
With inlet port female thread block  
**-F6**

- 3-port normally closed (NC)**  
With outlet port single use fitting block  
**-FJ6A**
- 3-port normally open (NO)**  
With outlet port single use fitting block  
**-FJ6B**
- 3-port normally closed (NC)**  
With outlet port female thread block  
**-FMA**  
**-FMAH**
- 3-port normally open (NO)**  
With outlet port female thread block  
**-FMB**  
**-FMBH**

- 3-port normally open (NO)**  
With outlet port female thread block  
With inlet port female thread block  
**-F4B**  
**-F4BH**
- 3-port normally closed (NC)**  
With outlet port single use fitting block  
With inlet port female thread block  
**-F4B**  
**-F4BH**
- 3-port normally open (NO)**  
With outlet port single use fitting block  
With inlet port female thread block  
**-F5A**  
**-F5B**
- 3-port normally closed (NC)**  
With outlet port single use fitting block  
With inlet port female thread block  
**-F6A**  
**-F6B**

## Wiring specification

- L type plug connector  
Without connector  
**Blank**
- S type plug connector  
Without connector  
**-PN**
- S type plug connector  
Lead wire 300 mm [11.8 in.]  
**-PS**
- L type plug connector  
Lead wire 300 mm [11.8 in.]  
**-PL**
- S type plug connector  
Lead wire 3000 mm [118 in.]  
**-PS3**
- L type plug connector  
Lead wire 3000 mm [118 in.]  
**-PL3**
- DIN connector type  
with indicator  
**-39L**
- DIN connector type  
without connector  
**-39N**

## Valve specification

- T0**: 2-position, for single solenoid only
- T1**: 2-position single solenoid specification (for both single and double solenoid use)
- T2**: 2-position double solenoid specification (for both single and double solenoid use)
- T3**: 3-position closed center
- T4**: 3-position exhaust center
- T5**: 3-position pressure center
- TA**: Tandem 3-port (NC and NC)
- TB**: Tandem 3-port (NO and NO)
- TC**: Tandem 3-port (NC and NO)

## Operation type

- Blank**  
Internal pilot type
  - G**  
External pilot type (for positive pressure)
  - V**  
External pilot type (for vacuum)  
※ This is a vacuum valve.
- Note: When using as a single unit, select **-A2** (A type with sub-base) for the valve outlet type. Without a sub-base, piping for the external pilot is not possible.

## Manual override

- Manual override button  
**Blank**
- No protrusion with DIN connector  
Manual override lever  
**-R**
- Protruding locking type  
**-83**

- With outlet port female thread block  
**-FM**  
**-FMH**
- With outlet port dual use fitting block  
With inlet port female thread block  
**-F3**
- With outlet port dual use fitting block  
With inlet port female thread block  
**-F3**
- With outlet port dual use fitting block  
With inlet port female thread block  
**-F3**

- With outlet port female thread block  
**-FM**  
**-FMH**
- With outlet port single use fitting block  
**-FJ5A**
- With outlet port single use fitting block  
**-FJ5B**
- With outlet port single use fitting block  
**-FJ5A**
- With outlet port single use fitting block  
**-FJ5B**

- With outlet port female thread block  
**-FMA**  
**-FMAH**
- With outlet port female thread block  
**-FMB**  
**-FMBH**
- With outlet port female thread block  
**-F4A**  
**-F4AH**
- With outlet port female thread block  
**-F4B**  
**-F4BH**

- With outlet port single use fitting block  
With inlet port female thread block  
**-F5A**  
**-F5B**
- With outlet port single use fitting block  
With inlet port female thread block  
**-F6A**  
**-F6B**
- With outlet port single use fitting block  
With inlet port female thread block  
**-F6A**  
**-F6B**
- With outlet port single use fitting block  
With inlet port female thread block  
**-F6A**  
**-F6B**

Valve size	Valve specification	Operation type	IP specification	Manual override	Valve outlet type	UL standard compliant	Wiring specification	Voltage
F10	T0 T1	Blank	Blank	Blank	Blank -F4 -F4H -F5 -F6 -FJ6 -FJ6A -FJ6B -FMA -FMAH -FMB -FMBH -F4A -F4AH -F4B -F4BH -F5A -F5B -F6A -F6B	Blank -UR: UL standard compliant	Blank -PN -PS -PL -PS3 -39L -39N	DC24V DC12V AC100V AC120V AC240V
F10L	T2 T3	G	Blank	-R	-F4 -F4H -F5 -F6 -FJ6 -FJ6A -FJ6B -FMA -FMAH -FMB -FMBH -F4A -F4AH -F4B -F4BH -F5A -F5B -F6A -F6B	Blank -UR: UL standard compliant	Blank -PN -PS -PL -PS3 -39L -39N	DC12V AC100V AC120V AC240V
F15	T4 T5	V	-P	-83	-F4 -F4H -F5 -F6 -FJ6 -FJ6A -FJ6B -FMA -FMAH -FMB -FMBH -F4A -F4AH -F4B -F4BH -F5A -F5B -F6A -F6B	Blank -UR: UL standard compliant	Blank -PN -PS -PL -PS3 -39L -39N	AC100V AC120V AC240V
F15L	TA TB TC	V	-P	-83	-F4 -F4H -F5 -F6 -FJ6 -FJ6A -FJ6B -FMA -FMAH -FMB -FMBH -F4A -F4AH -F4B -F4BH -F5A -F5B -F6A -F6B	Blank -UR: UL standard compliant	Blank -PN -PS -PL -PS3 -39L -39N	AC100V AC120V AC240V

Notes: 1. When the valve specification is T1 or T2, the manual override lever is placed only on the A side. This is not available with -39□.  
 2. Two manifold mounting screws are included.  
 3. Not available in external pilot type and vacuum valves.  
 4. Not available in external pilot type and vacuum valves.  
 5. Only for valve specification T0, T1, and T2.  
 6. Thread size for the inlet port female thread block is F10: M5 × 0.8, F15: Rc1/8.  
 7. Not available in low-current type.  
 8. Not available in low-current type and tandem 3-port valves.  
 9. Only for wiring specification -39□.  
 10. Only for F15 series and not available for valve specification T1, TA, TB, and TC. In addition, the valve is used only as a double solenoid for T2.  
 11. Not available with DIN connectors.  
 12. Not available in UR.  
 13. IP65 compliant protective construction to protect against intrusion of dust and water from outside.  
 Remark: Negative common specifications are also available as made to order products (add -129W to the end of order code). For details, consult us.

# F10, F15 Series Single Valve Unit Additional Parts Order Codes

## ● For internal pilot

F  Z -

**Valve size**

10: 10 mm  
[0.394 in.] width  
15: 15 mm  
[0.591 in.] width

**Parts content**

- 21** : Mounting bracket (mounting bracket, 2 mounting screws)
- 25** : Sub-base Rc1/8 (sub-base body, gasket, exhaust valve)<sup>Note 1</sup>
- 25H** : Sub-base NPT1/8 (sub-base body, gasket, exhaust valve)<sup>Note 1</sup>
- P** : Plate (plate, gasket, 2 mounting screws)
- J** : Dual use fitting block (fitting block, gasket, 2 mounting screws)
- J5** : Single use fitting block **F10**: φ 4, **F15**: φ 6 (fitting block, gasket, 2 mounting screws)
- J6** : Single use fitting block **F10**: φ 6, **F15**: φ 8 (fitting block, gasket, 2 mounting screws)
- J5A** : Single use fitting block for 3-port **F10**: φ 4, **F15**: φ 6 (fitting block, gasket, 2 mounting screws)<sup>Note 3</sup>
- J6A** : Single use fitting block for 3-port **F10**: φ 6, **F15**: φ 8 (fitting block, gasket, 2 mounting screws)<sup>Note 3</sup>
- M** : Female thread block **F10**: M5 × 0.8 **F15**: Rc1/8 (female thread block, gasket, 2 mounting screws)
- MH** : Female thread block **F10**: 10-32UNF **F15**: NPT1/8 (female thread block, gasket, 2 mounting screws)
- MA** : Female thread block for 3-port **F10**: M5 × 0.8 **F15**: Rc1/8 (female thread block, gasket, 2 mounting screws)<sup>Note 3</sup>
- MAH** : Female thread block for 3-port **F10**: 10-32UNF **F15**: NPT1/8 (female thread block, gasket, 2 mounting screws)<sup>Note 3</sup>
- MP** : P port female thread block **F10**: M5 × 0.8 **F15**: Rc1/8 (P port female thread block, gasket)<sup>Note 1</sup>
- MPH** : P port female thread block **F10**: 10-32UNF **F15**: NPT1/8 (P port female thread block, gasket)<sup>Note 1</sup>
- GS1** : Gasket (gasket, exhaust valve)<sup>Note 2</sup>

Notes: 1. Valve mounting screws are not included.  
2. Caution should be exercised as this gasket is different from the **GS2** gasket for the split-type manifolds.  
3. Common to both normally closed (NC) and normally open (NO) types. Select the mounting direction by application requirements.

## ● For external pilot

F  Z -

**Valve size**

10: 10 mm  
[0.394 in.] width  
15: 15 mm  
[0.591 in.] width

**Parts content**

- P** : Plate (plate, gasket, 2 mounting screws)
- J** : Dual use fitting block (fitting block, gasket, 2 mounting screws)
- J5** : Single use fitting block **F10**: φ 4, **F15**: φ 6 (fitting block, gasket, 2 mounting screws)
- J6** : Single use fitting block **F10**: φ 6, **F15**: φ 8 (fitting block, gasket, 2 mounting screws)
- J5A** : Single use fitting block for 3-port **F10**: φ 4, **F15**: φ 6 (fitting block, gasket, 2 mounting screws)<sup>Note 1</sup>
- J6A** : Single use fitting block for 3-port **F10**: φ 6, **F15**: φ 8 (fitting block, gasket, 2 mounting screws)<sup>Note 1</sup>
- M** : Female thread block **F10**: M5 × 0.8 **F15**: Rc1/8 (female thread block, gasket, 2 mounting screws)
- MH** : Female thread block **F10**: 10-32UNF **F15**: NPT1/8 (female thread block, gasket, 2 mounting screws)
- MA** : Female thread block for 3-port **F10**: M5 × 0.8 **F15**: Rc1/8 (female thread block, gasket, 2 mounting screws)<sup>Note 1</sup>
- MAH** : Female thread block for 3-port **F10**: 10-32UNF **F15**: NPT1/8 (female thread block, gasket, 2 mounting screws)<sup>Note 1</sup>
- GS1** : Gasket (gasket, exhaust valve)<sup>Note 2</sup>

Notes: 1. Common to both normally closed (NC) and normally open (NO) types. Select the mounting direction by application requirements.  
2. Caution should be exercised as this gasket is different from the **GS2** gasket for the split type manifolds.

## Sub-base for external pilot

F  ZG - 25

**Valve size**

10: 10 mm [0.394 in.] width  
15: 15 mm [0.591 in.] width  
Sub-base Rc1/8

F  ZG - 25H

**Valve size**

10: 10 mm [0.394 in.] width  
15: 15 mm [0.591 in.] width  
Sub-base NPT1/8

ORDER CODES

## Connector-related order codes

JAZ -  -

UL standard compliant<sup>Note 1</sup>  
Blank: -  
UR :UL standard compliant

**Valve specification**  
For **T1, T2, T3, T4, T5, TA, TB, TC**

**Connector specification**  
**CP** : Connector, lead wire length 300 mm [11.8 in.] (black, red, white, for total of 3 lead wires)  
**CP3** : Connector, lead wire length 3000 mm [118 in.] (black, red, white, for total of 3 lead wires)  
**CPN** : Connector without lead wire (1 short bar and 3 contacts included)

Remarks: A connector for negative common is also available. See p. 19 for details. (Not, available in UR.)  
Note.1: For the lead wire gauge, blank is 24AWG and UR is 22AWG.

JAZO -  -

UL standard compliant<sup>Note 1</sup>  
Blank: -  
UR :UL standard compliant

**Valve specification**  
For **T0**

**Connector specification**  
**CP** : Connector, lead wire length 300 mm [11.8 in.] (black, red, for total of 2 lead wires)  
**CP3** : Connector, lead wire length 3000 mm [118 in.] (black, red, for total of 2 lead wires)  
**CPN** : Connector without lead wire (1 short bar, 2 contacts included)

FZ -

**Valve specification**  
For **T1, T2, T3, T4, T5, TA, TB, TC**

**Connector specification**  
**CC1.5** : Cabtyre cable length 1500 mm [59 in.]<sup>\*</sup>  
**CC3** : Cabtyre cable length 3000 mm [118 in.]<sup>\*</sup>

<sup>\*</sup> For details, see p. 19.

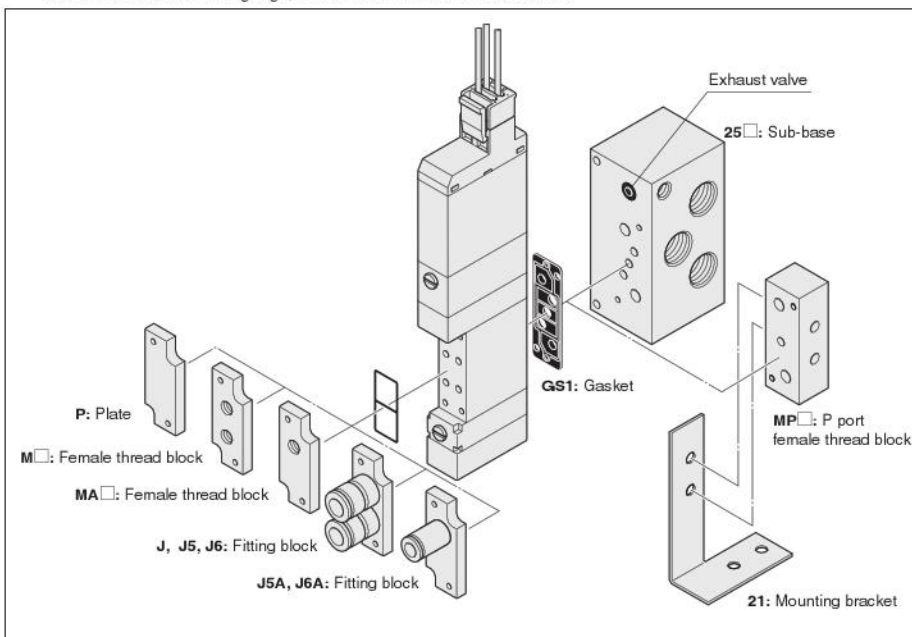

# F10, F15 Series Monoblock Manifold A Type (Base Piping Type) Order Codes

### Valve size

**F10M** 10 mm [Ø.394 in.] width

**F15M** 15 mm [Ø.591 in.] width

### Operation type

**Blank** Internal pilot type<sup>Note4</sup>

**G** External pilot type<sup>Note5</sup> (for positive pressure)

**V** External pilot type<sup>Note5</sup> (for vacuum)<sup>\*</sup>  
\* : This is a vacuum valve.

Note: Cannot be mounted together with a positive pressure valve.

### Wiring specification

L type plug connector  
Without connector

S type plug connector  
Without connector

Pre-wired positive common terminal  
L type plug connector  
Lead wire 300 mm [11.8 in.]

Pre-wired positive common terminal  
S type plug connector  
Lead wire 300 mm [11.8 in.]

Pre-wired positive common terminal  
L type plug connector  
Lead wire 3000 mm [118 in.]

Pre-wired positive common terminal  
S type plug connector  
Lead wire 3000 mm [118 in.]

DIN connector type with indicator<sup>Note12</sup>

DIN connector type without connector<sup>Note12</sup>

### Individual air supply and exhaust spacer, stop valve

**Blank** : No spacer and no stop valve

**-NPM** : Individual air supply spacer (with M5 female thread for F10)<sup>Note15</sup>

**-NP6** : Individual air supply spacer (with φ6 fitting for F15)<sup>Note15</sup>

**-NP8** : Individual air supply spacer (with φ8 fitting for F15)<sup>Note15</sup>

**-NRM** : Individual exhaust spacer (with M5 female thread for F10)<sup>Note15</sup>

**-NR6** : Individual exhaust spacer (with φ6 fitting for F15)<sup>Note15</sup>

**-NR8** : Individual exhaust spacer (with φ8 fitting for F15)<sup>Note15</sup>

**-STP** : With stop valve<sup>Note4</sup>

For details, see p. 23, 25.

### Manifold outlet specification

With dual use fitting blocks (base piping type)

**J**

With selectable fittings (base piping type)

**L**

Outlet port fitting  
F10: φ4, φ6  
F15: φ6, φ8

Outlet port should be selected in accordance with the manifold fitting specification.

With female thread blocks (base piping type)

**M**

Outlet port female thread  
F10: M5 × O8  
F15: Rc1.8

### Valve specification

**T0** : 2-position, for single solenoid only

**T1** : 2-position, single solenoid specification

**T2** : 2-position, double solenoid specification

**T3** : 3-position, closed center

**T4** : 3-position, exhaust center<sup>Note6</sup>

**T5** : 3-position, pressure center<sup>Note6</sup>

**TA** : Tandem 3-port (NC and NC)<sup>Note7</sup>

**TB** : Tandem 3-port (NO and NO)<sup>Note7</sup>

**TC** : Tandem 3-port (NC and NO)<sup>Note7</sup>

### Valve size

**F10** Standard type

**F10L** Low-current type

**F15** Standard type

**F15L** Low-current type

Note: Valves of F10□ and F15□ cannot be mounted together.

### Pilot specification

**Blank** Internal pilot manifold

**G** External pilot manifold

### Manual override

Manual override button

**Blank**

No protrusion with DIN connector

Manual override lever<sup>Note2</sup>

**-R**

Protruding locking type

**-83**

### Valve outlet type

With plate<sup>Note3</sup> (base piping type)

**-A1**

### Manifold fitting specification

#### 5-port specification

**-J5** With single use fitting block<sup>Note13</sup> (base piping type) F10: φ4 F15: φ6

**-J6** With single use fitting block<sup>Note13</sup> (base piping type) F10: φ6 F15: φ8

**-M** With female thread block<sup>Note13</sup> (base piping type) F10: M5 × O.8 F15: Rc1.8

**-MH** With female thread block<sup>Note14</sup> (base piping type) F10: 10-32UNF F15: NPT1.8

#### 3-port specification

**-J5A** With single use fitting block, normally closed (NC)<sup>Note13</sup> (base piping type) F10: φ4 F15: φ6

**-J5B** With single use fitting block, normally open (NO)<sup>Note13</sup> (base piping type) F10: φ4 F15: φ6

**-J6A** With single use fitting block, normally closed (NC)<sup>Note13</sup> (base piping type) F10: φ6 F15: φ8

**-J6B** With single use fitting block, normally open (NO)<sup>Note13</sup> (base piping type) F10: φ6 F15: φ8

**-MA** With female thread block, normally closed (NC)<sup>Note13</sup> (base piping type) F10: M5 × O.8 F15: Rc1.8

**-MAH** With female thread block, normally open (NO)<sup>Note14</sup> (base piping type) F10: 10-32UNF F15: NPT1.8

**-MB** With female thread block, normally open (NO)<sup>Note13</sup> (base piping type) F10: M5 × O.8 F15: Rc1.8

**-MBH** With female thread block, normally open (NO)<sup>Note14</sup> (base piping type) F10: 10-32UNF F15: NPT1.8

Caution: The 3-port specifications are only available in the valve specification T0, T1, and T2.

#### Back pressure prevention valve

**Blank** No back pressure prevention valve

**-E1** With back pressure prevention valve<sup>Note8</sup>

Valve size	Valve units	Manifold type	Manifold outlet specification	Pilot specification	Station	Valve size	Valve specification	Operation type	IP specification	Manual override	Valve outlet type	Wiring specification	Manifold fitting specification	Back pressure prevention valve	Individual air supply and exhaust spacer, stop valve	Voltage
Manifold model				Mounting valve model												
F10M	2	A	J	Blank	stn. 1 ⋮ stn. □ Note1	F10	T0	TA <sup>Note7</sup>	Blank <sup>Note4</sup>	Blank	Blank	-A1 <sup>Note3</sup>	Blank	Blank	Blank	DC24V
						F10L	T1	TB <sup>Note7</sup>								
F15M	20	A	L	Blank	stn. 1 ⋮ stn. □ Note1	F10	T2	TC <sup>Note7</sup>	Blank <sup>Note4</sup>	Blank	Blank	-A1 <sup>Note3</sup>	Blank	Blank	Blank	DC24V
						F15	T3	TC <sup>Note7</sup>								

Notes: 1. Valve mounting location is from the left, with the solenoid on top, and the 4(A), 2(B) ports side in front.

2. When the valve specification is T1 or T2, the manual override lever is placed only on the A side. This is not available with -39□.

3. Always enter -A1.

4. Cannot be mounted on the external pilot manifold.

5. Cannot be mounted on the internal pilot manifold.

6. Not available in the vacuum valves.

7. Not available in external pilot type and vacuum valves.

8. Not available with the individual exhaust spacer and vacuum valve.

9. Not available in low-current type.

10. Not available in low-current type and tandem 3-port valves.

11. Only for wiring specification -39□.

12. Only for F15 Series and not available for valve specification T1, TA, TB, and TC. In addition, the valve is used only as a double solenoid for T2.

13. Can be selected only when the manifold type is A.

14. Can be selected only when the manifold type is AH.

15. Not available with DIN connectors (-39□).

16. IP65 compliant protective construction to protect against intrusion of dust and water from outside.

Remark: Negative common specifications are also available as made to order products (add -129W to the ends of the valve and manifold model order codes). For details, consult us.

**Gasket (gasket and exhaust valve)**

F  Z - GS1

Valve size  
10: 10 mm [0.394 in.] width  
15: 15 mm [0.591 in.] width

**Block-off plate (block-off plate and 2 mounting screws)**

F  BP

Valve size  
10: 10 mm [0.394 in.] width  
15: 15 mm [0.591 in.] width

**Connector-related order codes**

JAZ  -

※For details, see p. 19.

Valve specification

Blank: For T1, T2, T3, T4, T5, TA, TB, TC  
0: For T0

Connector specification

- CP : Connector, lead wire length 300 mm [11.8 in.]
- CP3 : Connector, lead wire length 3000 mm [118 in.]
- CPN : Connector without lead wire (short bar and contacts included)
- PA : Positive common A type, lead wire length 300 mm [11.8 in.]\*
- PA3 : Positive common A type, lead wire length 3000 mm [118 in.]\*
- PB : Positive common B type, lead wire length 300 mm [11.8 in.]\*
- PB3 : Positive common B type, lead wire length 3000 mm [118 in.]\*
- PC : Positive common C type, lead wire length 300 mm [11.8 in.]\*
- PC3 : Positive common C type, lead wire length 3000 mm [118 in.]\*

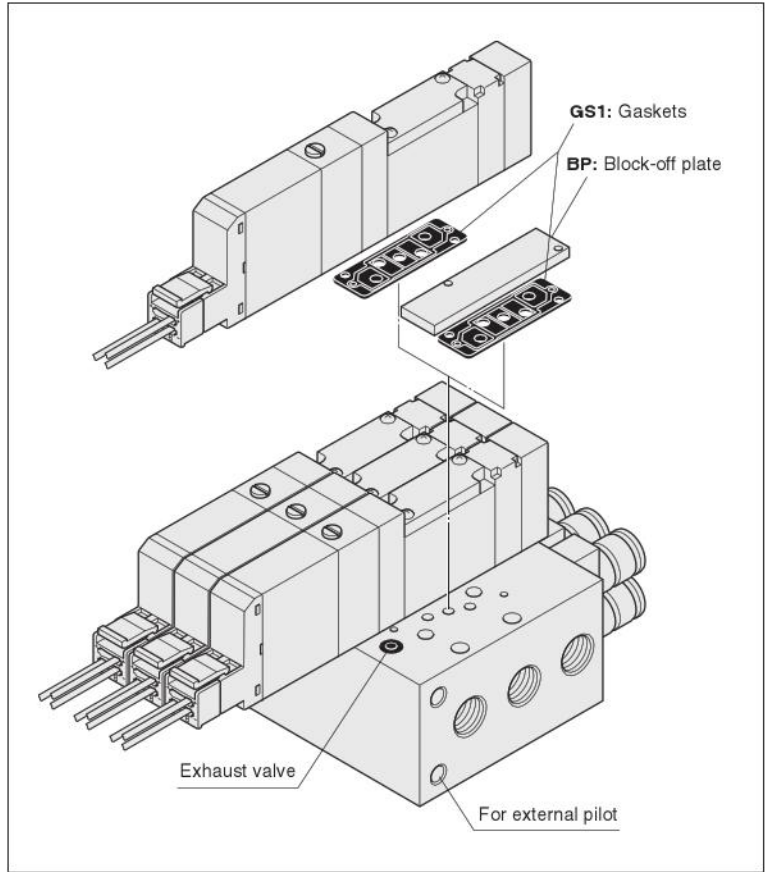

ORDER CODES

FZ -

Valve specification  
For T1, T2, T3, T4, T5, TA, TB, TC

Connector specification

- CC1.5 : Cabtyre cable length 1500 mm [59 in.]\*
- CC3 : Cabtyre cable length 3000 mm [118 in.]\*

**Common connector assembly**

A type: JAZ-PA \*

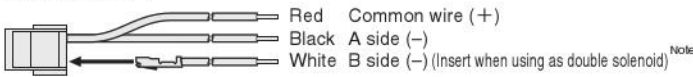

B type: JAZ-PB \*

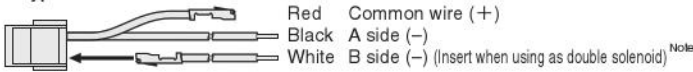

C type: JAZ-PC \*

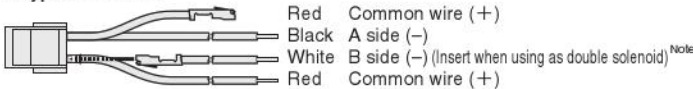

※ Lead wire length Blank: 300 mm [11.8 in.] Note: White lead wire is not available for JAZO-P   .  
3: 3000 mm [118 in.]

Remark: Connector for negative common type also available. For details, see p.19.

**Back pressure prevention valve (for monoblock type, 2 pieces)**

F  Z - E1

Valve size  
10: 10 mm [0.394 in.] width  
15: 15 mm [0.591 in.] width

**Individual air supply and exhaust spacer (Spacer for non-plug-in type, gasket, exhaust valve, and 2 mounting screws)**

F  Z -

Valve size  
10: 10 mm [0.394 in.] width  
15: 15 mm [0.591 in.] width

Specification

- NPM : Individual air supply spacer (with M5 female thread for F10)
- NP6 : Individual air supply spacer (with φ 6 fitting for F15)
- NP8 : Individual air supply spacer (with φ 8 fitting for F15)
- NRM : Individual exhaust spacer (with M5 female thread for F10)
- NR6 : Individual exhaust spacer (with φ 6 fitting for F15)
- NR8 : Individual exhaust spacer (with φ 8 fitting for F15)

※For details, see p. 25.  
※Not available with DIN connectors (-39 ).

**Muffler**

KM - J

Fitting size

- 6: Outer diameter φ 6 (for individual exhaust spacer)
  - 8: Outer diameter φ 8 (for individual exhaust spacer)
- (Sales unit: Set of 10 mufflers)

**Manifold Order Code Example**

(6 units of F10 Series)

**F10M6AL**

- stn.1 ~ 2 F10T0-A1-PS-J5 DC24V
- stn.3 ~ 5 F10T2-A1-PS-J6 DC24V
- stn.6 F10BP-J6

Note: This order code example has no relationship to the illustration at upper right.

**Precautions for Order Codes**

**Manifold outlet specification**

Select from among "dual use fitting blocks", "with female thread blocks" or "with selectable fittings." For repair or replacement, purchase the single valve unit additional parts, F  Z-J  (dual use fitting block), F  Z-J  (single use fitting block), or F  Z-M  (female thread block), on p. 45.

**Orders for valves only**

Place orders from "Single Valve Unit Order Codes" on p. 44. Note, however, that the only available valve outlet type is A1. In addition, for common terminal wiring connections, order the common connector assemblies listed above separately.

# F10, F15 Series Monoblock Manifold F Type (Direct Piping Type) Order Codes

## Valve size

**F10M**

10 mm [0.394 in.] width

**F15M**

15 mm [0.591 in.] width

## Valve specification

- T0** : 2-position, for single solenoid only
- T1** : 2-position, single solenoid specification
- T2** : 2-position, double solenoid specification
- T3** : 3-position, closed center
- T4** : 3-position, exhaust center
- T5** : 3-position, pressure center
- TA** : Tandem 3-port (NC and NC)
- TB** : Tandem 3-port (NO and NO)
- TC** : Tandem 3-port (NC and NO)

## Manual override

Manual override button



No protrusion with DIN connector

Manual override lever <sup>Note2</sup>

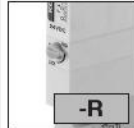

Protruding locking type <sup>Note6</sup>



## Valve size

- F10** Standard type
- F10L** Low-current type
- F15** Standard type
- F15L** Low-current type

Note: Valves of **F10** and **F15** cannot be mounted together.

## Valve outlet type

### 5-port specification

- FJ** With dual use fitting block <sup>Note8</sup> (direct piping type) **F10**: φ4, φ6 **F15**: φ6, φ8
- FJ5** With single use fitting block <sup>Note8</sup> (direct piping type) **F10**: φ4 **F15**: φ6
- FJ6** With single use fitting block <sup>Note8</sup> (direct piping type) **F10**: φ6 **F15**: φ8
- FM** With female thread block <sup>Note8</sup> (direct piping type) **F10**: M5 × 0.8 **F15**: Rc1.8
- FMH** With female thread block <sup>Note9</sup> (direct piping type) **F10**: 10-32UNF **F15**: NPT1.8

### 3-port specification

- FJ5A** With single use fitting block, normally closed (NC) <sup>Note8</sup> (direct piping type) **F10**: φ4 **F15**: φ6
- FJ5B** With single use fitting block, normally open (NO) <sup>Note8</sup> (direct piping type) **F10**: φ4 **F15**: φ6
- FJ6A** With single use fitting block, normally closed (NC) <sup>Note8</sup> (direct piping type) **F10**: φ6 **F15**: φ8
- FJ6B** With single use fitting block, normally open (NO) <sup>Note8</sup> (direct piping type) **F10**: φ6 **F15**: φ8
- FMA** With female thread block, normally closed (NC) <sup>Note8</sup> (direct piping type) **F10**: M5 × 0.8 **F15**: Rc1.8
- FMAH** With female thread block, normally closed (NC) <sup>Note9</sup> (direct piping type) **F10**: 10-32UNF **F15**: NPT1.8
- FMB** With female thread block, normally open (NO) <sup>Note8</sup> (direct piping type) **F10**: M5 × 0.8 **F15**: Rc1.8
- FMBH** With female thread block, normally open (NO) <sup>Note9</sup> (direct piping type) **F10**: 10-32UNF **F15**: NPT1.8

Caution: The 3-port specifications are only available in the valve specification **T0**, **T1**, and **T2**.

## Wiring specification

L type plug connector  
Without connector

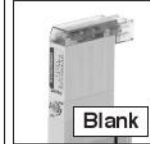

S type plug connector  
Lead wire 3000 mm [118 in.]



Pre-wired positive common terminal  
S type plug connector  
Lead wire 3000 mm [118 in.]

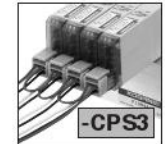

S type plug connector  
Without connector

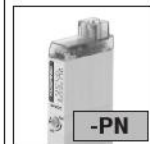

L type plug connector  
Lead wire 3000 mm [118 in.]

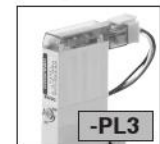

Pre-wired positive common terminal  
L type plug connector  
Lead wire 3000 mm [118 in.]

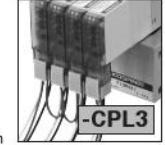

S type plug connector  
Lead wire 300 mm [11.8 in.]

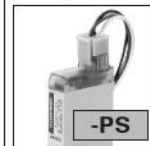

Pre-wired positive common terminal  
S type plug connector  
Lead wire 300 mm [11.8 in.]

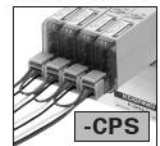

L type plug connector  
Lead wire 300 mm [11.8 in.]

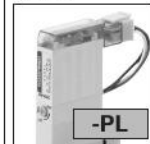

Pre-wired positive common terminal  
L type plug connector  
Lead wire 300 mm [11.8 in.]

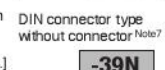
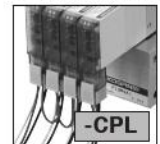

## Individual air supply and exhaust spacer, stop valve

- Blank** : No spacer and no stop valve
- NPM** : Individual air supply spacer (with M5 female thread for F10) <sup>Note10</sup>
- NP6** : Individual air supply spacer (with φ6 fitting for F15) <sup>Note10</sup>
- NP8** : Individual air supply spacer (with φ8 fitting for F15) <sup>Note10</sup>
- NRM** : Individual exhaust spacer (with M5 female thread for F10) <sup>Note10</sup>
- NR6** : Individual exhaust spacer (with φ6 fitting for F15) <sup>Note10</sup>
- NR8** : Individual exhaust spacer (with φ8 fitting for F15) <sup>Note10</sup>
- STP** : With stop valve

For details, see p. 23, 25.

## Back pressure prevention valve

- Blank** No back pressure prevention valve
- E1** With back pressure prevention valve <sup>Note3</sup>

Valve size	Valve units	Manifold type	Station	Valve size	Valve specification	IP specification	Manual override	Valve outlet type	Wiring specification	Back pressure prevention valve	Individual air supply and exhaust spacer, stop valve	Voltage
F10M F15M	2 ⋮ 20	F FH	stn. 1 ⋮ stn. □ <sup>Note1</sup>	F10 F10L F15 F15L	T0 TA T1 TB T2 TC T3 T4 T5	Blank -P <sup>Note11</sup>	Blank -R <sup>Note2</sup> -83 <sup>Note6</sup>	-FJ <sup>Note8</sup> -FJ5 <sup>Note8</sup> -FJ6 <sup>Note8</sup> -FM <sup>Note8</sup> -FMH <sup>Note9</sup> -FJ5A <sup>Note8</sup> -FJ5B <sup>Note8</sup> -FJ6A <sup>Note8</sup> -FJ6B <sup>Note8</sup> -FMA <sup>Note8</sup> -FMAH <sup>Note9</sup> -FMB <sup>Note8</sup> -FMBH <sup>Note9</sup>	Blank -CPS -PN -CPL -PS -CPS3 -PL -CPL3 -PS3 -39L <sup>Note7</sup> -PL3 -39N <sup>Note7</sup>	Blank -E1 <sup>Note3</sup>	Blank -NPM <sup>Note10</sup> -NP6 <sup>Note10</sup> -NP8 <sup>Note10</sup> -NRM <sup>Note10</sup> -NR6 <sup>Note10</sup> -NR8 <sup>Note10</sup> -STP	DC24V DC12V <sup>Note4</sup> AC100V <sup>Note5, 10</sup> AC120V <sup>Note5</sup> AC240V <sup>Note5, 6</sup>
BP (for block-off plate)												
Blank -STP												

- Notes: 1. Valve mounting location is from the left, with the solenoid on top, and the 4(A), 2(B) ports side in front.  
 2. When the valve specification is **T1** or **T2**, the manual override lever is placed only on the A side. This is not available with **-39** □.  
 3. Not available with the individual exhaust spacer.  
 4. Not available in low-current type.  
 5. Not available in low-current type and tandem 3-port valves.  
 6. Only for wiring specification **-39** □.

7. Only for **F15** series and not available for valve specification **T1**, **TA**, **TB**, and **TC**. In addition, the valve is used only as a double solenoid for **T2**.  
 8. Can be selected only when the manifold type is **F**.  
 9. Can be selected only when the manifold type is **FH**.  
 10. Not available with DIN connectors (**-39** □).  
 11. IP65 compliant protective construction to protect against intrusion of dust and water from outside.  
 Remarks: 1. The external pilot type valve cannot be mounted on the F type manifold.  
 2. Negative common specifications are also available as made to order products (add **-129W** to the ends of the valve and manifold model order codes). For details, consult us.

**Gasket (gasket and exhaust valve)**

F  Z - GS1

Valve size  
 10: 10 mm [0.394 in.] width  
 15: 15 mm [0.591 in.] width

**Block-off plate (block-off plate and 2 mounting screws)**

F  BP

Valve size  
 10: 10 mm [0.394 in.] width  
 15: 15 mm [0.591 in.] width

**Connector-related order codes**

JAZ  -

※For details, see p. 19.

Valve specification

Blank: For T1, T2, T3, T4, T5, TA, TB, TC  
 0: For T0

Connector specification

- CP : Connector, lead wire length 300 mm [11.8 in.]
- CP3 : Connector, lead wire length 3000 mm [118 in.]
- CPN: Connector without lead wire (short bar, contacts included)
- PA : Positive common A type, lead wire length 300 mm [11.8 in.]\*
- PA3 : Positive common A type, lead wire length 3000 mm [118 in.]\*
- PB : Positive common B type, lead wire length 300 mm [11.8 in.]\*
- PB3 : Positive common B type, lead wire length 3000 mm [118 in.]\*
- PC : Positive common C type, lead wire length 300 mm [11.8 in.]\*
- PC3 : Positive common C type, lead wire length 3000 mm [118 in.]\*

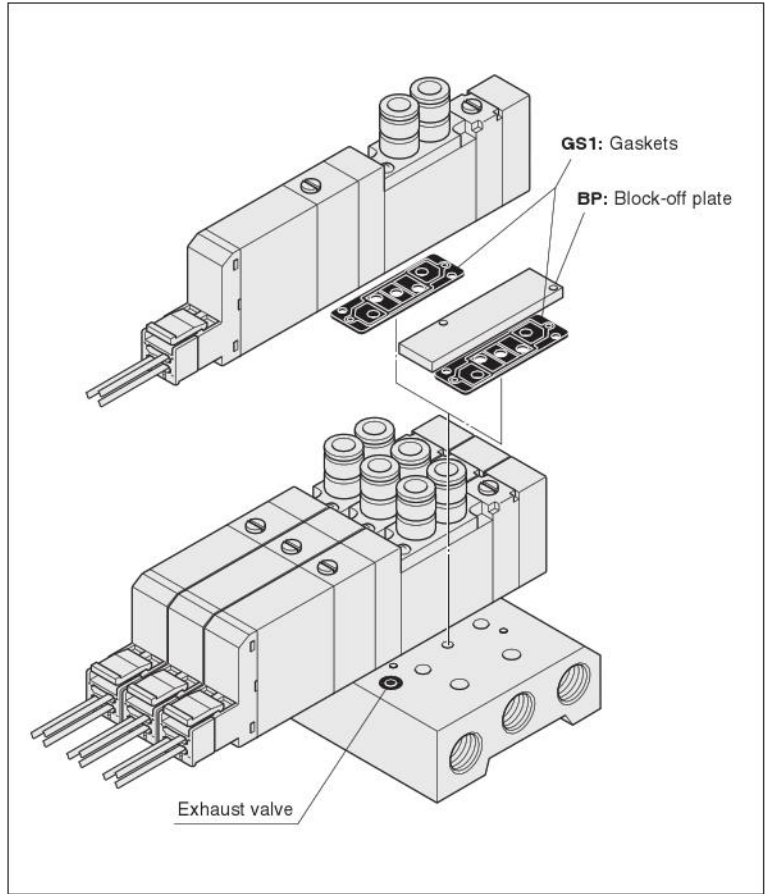

ORDER CODES

FZ -

Valve specification  
 For T1, T2, T3, T4, T5, TA, TB, TC

Connector specification

- CC1.5 : Cabtyre cable length 1500 mm [59 in.]\*
- CC3 : Cabtyre cable length 3000 mm [118 in.]\*

**Common connector assembly**

A type: JAZ-PA \*

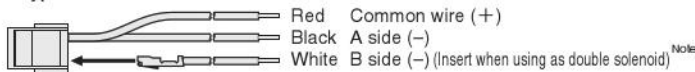

B type: JAZ-PB \*

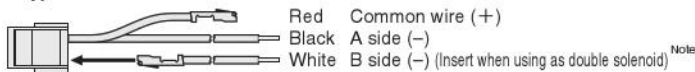

C type: JAZ-PC \*

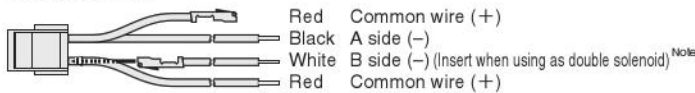

※ Lead wire length Blank: 300 mm [11.8 in.] Note: White lead wire is not available for JAZ0-P  .  
 3: 3000 mm [118 in.]

Remark: Connector for negative common type also available. For details, see p. 19.

**Back pressure prevention valve (for monoblock type, 2 pieces)**

F  Z - E1

Valve size  
 10: 10 mm [0.394 in.] width  
 15: 15 mm [0.591 in.] width

**Individual air supply and exhaust spacer (Spacer for non-plug-in type, gasket, exhaust valve, and 2 mounting screws)**

F  Z -

- |                             |   |
|-----------------------------|---|
| <b>Valve size</b>           | <b>Specification</b>  |
| 10: 10 mm [0.394 in.] width | <b>NPM</b> : Individual air supply spacer (with M5 female thread for F10) |
| 15: 15 mm [0.591 in.] width | <b>NP6</b> : Individual air supply spacer (with $\phi$ 6 fitting for F15) |
|                             | <b>NP8</b> : Individual air supply spacer (with $\phi$ 8 fitting for F15) |
|                             | <b>NRM</b> : Individual exhaust spacer (with M5 female thread for F10)    |
|                             | <b>NR6</b> : Individual exhaust spacer (with $\phi$ 6 fitting for F15)    |
|                             | <b>NR8</b> : Individual exhaust spacer (with $\phi$ 8 fitting for F15)    |

※For details, see p. 25.  
 ※Not available with DIN connectors (-39 ).

**Muffler**

KM - J

Fitting size  
 6: Outer diameter  $\phi$  6 (for individual exhaust spacer)  
 8: Outer diameter  $\phi$  8 (for individual exhaust spacer)  
 (Sales unit: Set of 10 mufflers)

**Manifold Order Code Example**

(4 units of F10 Series)

**F10M4F**

- stn.1 ~ 2 F10T0-FJ5-PS DC24V
- stn.3 F10T2-FJ6-PS DC24V
- stn.4 F10BP

Note: This order code example has no relationship to the illustration at upper right.

**Precautions for Order Codes**

**Orders for valves only**

Place orders from "Single Valve Unit Order Codes" on p. 44. Select from valve outlet types -FJ, -FJ5, -FJ6, -FM , -FJ5A, -FJ5B, -FJ6A, -FJ6B, -FMA , or -FMB . In addition, for common terminal wiring connections, order the common connector assemblies listed above separately.

# F10, F15 Series Monoblock Manifold A Type, Wire-Saving Type (Base Piping Type) Order Codes

### Valve size

**F10M** 10 mm [0.394 in.] width

**F15M** 15 mm [0.591 in.] width

### Operation type

**Blank** Internal pilot type<sup>Note5</sup>

**G** External pilot type<sup>Note6</sup> (for positive pressure)

**V** External pilot type<sup>Note6</sup> (for vacuum)<sup>Note8</sup>  
※: This is a vacuum valve.  
Note: Cannot be mounted together with a positive pressure valve.

### Manual override

Manual override button

**Blank**

Manual override lever<sup>Note3</sup>

**-R**

### Valve outlet type

With plate<sup>Note4</sup> (base piping type)

**-A1**

### Individual air supply and exhaust spacer, stop valve

**Blank**: No spacer and no stop valve

- NPM: Individual air supply spacer (with M5 female thread for F10)
- NP6: Individual air supply spacer (with φ6 fitting for F15)
- NP8: Individual air supply spacer (with φ8 fitting for F15)
- NRM: Individual exhaust spacer (with M5 female thread for F10)
- NR6: Individual exhaust spacer (with φ6 fitting for F15)
- NR8: Individual exhaust spacer (with φ8 fitting for F15)
- STP: With stop valve<sup>Note5</sup>

For details, see p. 23, 25.

### Manifold outlet specification

With dual use fitting blocks (base piping type)

**J**

With selectable fittings (base piping type)

**L**

With female thread blocks (base piping type)

**M**

Outlet port fitting  
F10: φ4, φ6  
F15: φ6, φ8

Outlet port should be selected in accordance with the manifold fitting specification.

Outlet port female thread  
F10: M5 × 0.8  
F15: Rc1/8

### Valve specification

**T0**: 2-position, for single solenoid only  
**T1**: 2-position, single solenoid specification  
**T2**: 2-position, double solenoid specification  
**T3**: 3-position, closed center  
**T4**: 3-position, exhaust center<sup>Note9</sup>  
**T5**: 3-position, pressure center<sup>Note9</sup>  
**TA**: Tandem 3-port (NC and NO)<sup>Note9</sup>  
**TB**: Tandem 3-port (NO and NO)<sup>Note9</sup>  
**TC**: Tandem 3-port (NC and NO)<sup>Note9</sup>

### Wiring specification

**-PN** S type plug connector<sup>Note4</sup>

### Manifold fitting specification

#### 5-port specification

**-J5** With single use fitting block<sup>Note13</sup> (base piping type)  
F10: φ4  
F15: φ6

**-J6** With single use fitting block<sup>Note13</sup> (base piping type)  
F10: φ6  
F15: φ8

**-M** With female thread block<sup>Note13</sup> (base piping type)  
F10: M5 × 0.8  
F15: Rc1/8

**-MH** With female thread block<sup>Note14</sup> (base piping type)  
F10: 10-32UNF  
F15: NPT1/8

#### 3-port specification

**-J5A** With single use fitting block, normally closed (NC)<sup>Note13</sup> (base piping type)  
F10: φ4  
F15: φ6

**-J5B** With single use fitting block, normally open (NO)<sup>Note13</sup> (base piping type)  
F10: φ4  
F15: φ6

**-J6A** With single use fitting block, normally closed (NC)<sup>Note13</sup> (base piping type)  
F10: φ6  
F15: φ8

**-J6B** With single use fitting block, normally open (NO)<sup>Note13</sup> (base piping type)  
F10: φ6  
F15: φ8

**-MA** With female thread block, normally closed (NC)<sup>Note13</sup> (base piping type)  
F10: M5 × 0.8  
F15: Rc1/8

**-MAH** With female thread block, normally closed (NC)<sup>Note14</sup> (base piping type)  
F10: 10-32UNF  
F15: NPT1/8

**-MB** With female thread block, normally open (NO)<sup>Note13</sup> (base piping type)  
F10: M5 × 0.8  
F15: Rc1/8

**-MBH** With female thread block, normally open (NO)<sup>Note14</sup> (base piping type)  
F10: 10-32UNF  
F15: NPT1/8

**Caution:** The 3-port specifications are only available in the valve specification T0, T1, and T2.

### Wiring specifications (wiring block) (no power supply terminal only)

Flat cable connector (with socket and strain relief)

**-F**

D-sub connector

**-D25**

-F100N: 10-pin  
-F101N: 10-pin  
-F200N: 20-pin  
-F201N: 20-pin  
-F260N: 26-pin  
For details, see p. 92.

(M2.6 mounting screws)  
-D250N: 25-pin<sup>Note13</sup>  
-D251N: 25-pin<sup>Note13</sup>

(4-40UNC mounting screws)  
-D250NU: 25-pin<sup>Note14</sup>  
-D251NU: 25-pin<sup>Note14</sup>  
For details, see p. 92.

### Valve size

**F10** Standard type  
**F10L** Low-current type  
**F15** Standard type  
**F15L** Low-current type

Note: Valves of F10□ and F15□ cannot be mounted together.

### Wiring connection specification

**Blank** Packed wiring: Wired to match the specifications of the mounted valve.

**-W** Double wiring: Wiring is always for the double solenoid, regardless of the specifications of the mounted valve.

### Pilot specification

**Blank** Internal pilot manifold

**G** External pilot manifold

### Back pressure prevention valve

**Blank** No back pressure prevention valve

**-E1** With back pressure prevention valve<sup>Note10</sup>

Valve size

Valve units

Manifold type

Manifold outlet specification

Pilot specification

Wiring specifications

Wiring connection specification

Station

Valve size

Valve specification

Operation type

Manual override

Valve outlet type

Wiring specification

Manifold fitting specification

Back pressure prevention valve

Individual air supply and exhaust spacer, stop valve

Voltage

Manifold model

Mounting valve model

F10M	2 ⋮ Note1	A	J M	Blank G	-F100N -F101N -F200N -F201N -F260N -D250N -D251N	Blank -W	stn. 1 ⋮ stn. □ Note2	F10 F10L F15 F15L	T0 T1 T2 T3 T4 <sup>Note8</sup> T5 <sup>Note8</sup>	TA <sup>Note9</sup> TB <sup>Note9</sup> TC <sup>Note9</sup>	Blank <sup>Note5</sup> G <sup>Note6</sup> V <sup>Note6</sup>	Blank -R <sup>Note3</sup>	-A1 Note4	-PN Note4	Blank -E1 <sup>Note10</sup>	Blank -NPM -NP6 -NP8 -NRM -NR6 -NR8 -STP <sup>Note5</sup>	DC24V DC12V <sup>Note11</sup> AC100V <sup>Note12</sup> AC120V <sup>Note12</sup>
F15M	□ Note1	A	AH	Blank G	-F100N -F101N -F200N -F201N -F260N -D250N <sup>Note13</sup> -D251N <sup>Note13</sup> -D250NU <sup>Note14</sup> -D251NU <sup>Note14</sup>	Blank -W	stn. 1 ⋮ stn. □ Note2	F10 F10L F15 F15L	T0 T1 T2 T3 T4 <sup>Note8</sup> T5 <sup>Note8</sup>	TA <sup>Note9</sup> TB <sup>Note9</sup> TC <sup>Note9</sup>	Blank <sup>Note5</sup> G <sup>Note6</sup> V <sup>Note6</sup>	Blank -R <sup>Note3</sup>	-A1 Note4	-PN Note4	-J5 <sup>Note13</sup> -J6 <sup>Note13</sup> -M <sup>Note13</sup> -MH <sup>Note14</sup> -J5A <sup>Note13</sup> -J5B <sup>Note13</sup> -J6A <sup>Note13</sup> -J6B <sup>Note13</sup> -MA <sup>Note13</sup> -MAH <sup>Note14</sup> -MB <sup>Note13</sup> -MBH <sup>Note14</sup>	Blank -NPM -NP6 -NP8 -NRM -NR6 -NR8 -STP <sup>Note5</sup>	DC24V DC12V <sup>Note11</sup> AC100V <sup>Note12</sup> AC120V <sup>Note12</sup>

Notes: 1. For the maximum number of units, see the table for maximum number of valve units by wiring specification, on p. 51.  
 2. Valve mounting location is from the left, with the solenoid on top, and the 4(A), 2(B) ports side in front.  
 3. When the valve specification is T1 or T2, the manual override lever is placed only on the A side.  
 4. Always enter -A1 and -PN.  
 5. Cannot be mounted on the external pilot manifold.  
 6. Cannot be mounted on the internal pilot manifold.  
 7. Caution should be exercised that the block-off plate wiring is always double wiring (allocated 2 control pins at 1 stn.), regardless of the wiring connection specification. For single wiring, see p. 51.  
 8. Not available in the vacuum valves.  
 9. Not available in external pilot type and vacuum valves.  
 10. Not available with the individual exhaust spacer and vacuum valve.  
 11. Not available in low-current type.  
 12. Not available in low-current type and tandem 3-port valves. In addition, only available when the wiring specification is a D-sub connector.  
 13. Can be selected only when the manifold type is A.  
 14. Can be selected only when the manifold type is AH.

**Gasket (gasket and exhaust valve)**

F  Z - GS1

Valve size  
 10: 10 mm [0.394 in.] width  
 15: 15 mm [0.591 in.] width

**Block-off plate (block-off plate and 2 mounting screws)**

F  BP

Valve size  
 10: 10 mm [0.394 in.] width  
 15: 15 mm [0.591 in.] width

**Back pressure prevention valve (for monoblock type, 2 pieces)**

F  Z - E1

Valve size  
 10: 10 mm [0.394 in.] width  
 15: 15 mm [0.591 in.] width

**Individual air supply and exhaust spacer (Spacer for non-plug-in type, gasket, exhaust valve, and 2 mounting screws)**

F  Z -

Valve size      Specification  
 10: 10 mm      **NPM** : Individual air supply spacer (with M5 female thread for F10)  
                     [0.394 in.] width      **NP6** : Individual air supply spacer (with  $\phi$  6 fitting for F15)  
 15: 15 mm      **NP8** : Individual air supply spacer (with  $\phi$  8 fitting for F15)  
                     [0.591 in.] width      **NRM** : Individual exhaust spacer (with M5 female thread for F10)  
   **NR6** : Individual exhaust spacer (with  $\phi$  6 fitting for F15)  
   **NR8** : Individual exhaust spacer (with  $\phi$  8 fitting for F15)

※For details, see p. 25.

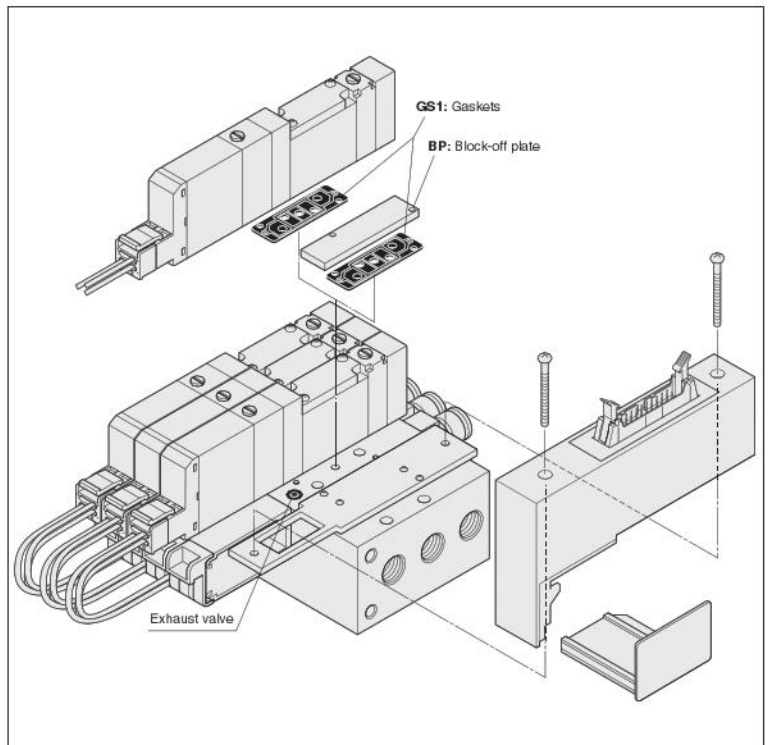

**Muffler**

KM - J

Fitting size  
**6**: Outer diameter  $\phi$  6 (for individual exhaust spacer)  
**8**: Outer diameter  $\phi$  8 (for individual exhaust spacer)  
 (Sales unit: Set of 10 mufflers)

**Manifold Order Code Example**

(6 units of F10 Series)

**F10M6AL-F201N**

stn.1 ~ 2    F10T0-A1-PN-J5 DC24V  
 stn.3 ~ 5    F10T2-A1-PN-J6 DC24V  
 stn.6        F10BP-J6

Note: This order code example has no relationship to the illustration at upper right.

**Table for maximum number of valve units by wiring specification**

		Maximum number of units	
		Wiring connection specification	
Wiring specification	Max. outputs	Packed wiring (Blank)	Double wiring (-W)
F100N Flat cable (10P)	8	Varies depending on the number of mounted single solenoids, double solenoids, and block-off plates. The number of controlled solenoids should be designated as the maximum number of outputs or less.	4 units
F101N Flat cable (10P)	8		4 units
F200N Flat cable (20P)	16		8 units
F201N Flat cable (20P)	16		8 units
F260N Flat cable (26P)	20		10 units
D250N <input type="checkbox"/> D-sub connector (25P)	16		8 units
D251N <input type="checkbox"/> D-sub connector (25P)	20	10 units	

**Precautions for Order Codes**

- **Manifold outlet specification**  
 Select from among "dual use fitting blocks", "with female thread blocks" or "with selectable fittings." For repair or replacement, purchase the single valve unit additional parts, F  Z-J (dual use fitting block), F  Z-J  (single use fitting block), or F  Z-M  (female thread block), on p. 45.
- **Orders for valves only**  
 Place orders from "Single Valve Unit Order Codes" on p. 44. Note, however, that the only available valve outlet type is **A1**.
- **Wiring connection specification**  
**Blank** (packed wiring): Wired to match the specifications of the mounted valve.  
**-W** (double wiring): Wiring is always for the double solenoid, regardless of the specifications of the mounted valve.

**Caution**

Caution should be exercised that the block-off plate wiring is always double wiring (allocated 2 control pins at 1 stn.), regardless of the wiring connection specification. The block-off plate wiring can be made as wiring for a single solenoid. Add **-1W** to the end of the block-off plate order code in the case. For details, consult us.

# F10, F15 Series Monoblock Manifold F Type, Wire-Saving Type (Direct Piping Type) Order Codes

### Valve size

**F10M**  
10 mm [0.394 in.] width

**F15M**  
15 mm [0.591 in.] width

### Valve specification

T0 : 2-position, for single solenoid only  
 T1 : 2-position, single solenoid specification  
 T2 : 2-position, double solenoid specification  
 T3 : 3-position, closed center  
 T4 : 3-position, exhaust center  
 T5 : 3-position, pressure center  
 TA : Tandem 3-port (NC and NC)  
 TB : Tandem 3-port (NO and NO)  
 TC : Tandem 3-port (NC and NO)

### Manual override

Manual override button

Blank

Manual override lever

-R

### Valve outlet type

#### 5-port specification

**-FJ** With dual use fitting block<sup>Note9</sup> (direct piping type) F10: φ 4, φ 6, φ 8 F15: φ 6, φ 8

**-FJ5** With single use fitting block<sup>Note9</sup> (direct piping type) F10: φ 4 F15: φ 6

**-FJ6** With single use fitting block<sup>Note9</sup> (direct piping type) F10: φ 6 F15: φ 8

**-FM** With female thread block<sup>Note9</sup> (direct piping type) F10: M5×0.8 F15: Rc1/8

**-FMH** With female thread block<sup>Note10</sup> (direct piping type) F10: 10-32UNF F15: NPT1/8

#### 3-port specification

**-FJ5A** With single use fitting block, normally closed (NC)<sup>Note9</sup> (direct piping type) F10: φ 4 F15: φ 6

**-FJ5B** With single use fitting block, normally open (NO)<sup>Note9</sup> (direct piping type) F10: φ 4 F15: φ 6

**-FJ6A** With single use fitting block, normally closed (NC)<sup>Note9</sup> (direct piping type) F10: φ 6 F15: φ 8

**-FJ6B** With single use fitting block, normally open (NO)<sup>Note9</sup> (direct piping type) F10: φ 6 F15: φ 8

**-FMA** With female thread block, normally closed (NC)<sup>Note9</sup> (direct piping type) F10: M5×0.8 F15: Rc1/8

**-FMAH** With female thread block, normally closed (NC)<sup>Note10</sup> (direct piping type) F10: 10-32UNF F15: NPT1/8

**-FMB** With female thread block, normally open (NO)<sup>Note9</sup> (direct piping type) F10: M5×0.8 F15: Rc1/8

**-FMBH** With female thread block, normally open (NO)<sup>Note10</sup> (direct piping type) F10: 10-32UNF F15: NPT1/8

**Caution:** The 3-port specifications are only available in the valve specification T0, T1, and T2.

### Wiring specification (wiring block)

(no power supply terminal only)

Flat cable connector (with socket and strain relief)

**-F**

**-F100N**: 10-pin  
**-F101N**: 10-pin  
**-F200N**: 20-pin  
**-F201N**: 20-pin  
**-F260N**: 26-pin  
 For details, see p. 92.

D-sub connector

**-D25**

(M2.6 mounting screws)  
**-D250N**: 25-pin<sup>Note9</sup>  
**-D251N**: 25-pin<sup>Note9</sup>  
 (4-40UNC mounting screws)  
**-D250NU**: 25-pin<sup>Note10</sup>  
**-D251NU**: 25-pin<sup>Note10</sup>  
 For details, see p. 92.

### Wiring connection specification

**Blank**  
**Packed wiring:** Wired to match the specifications of the mounted valve.

**-W**  
**Double wiring:** Wiring is always for the double solenoid, regardless of the specifications of the mounted valve.

### Valve size

**F10** Standard type  
**F10L** Low-current type  
**F15** Standard type  
**F15L** Low-current type

Note: Valves of **F10** and **F15** cannot be mounted together.

### Individual air supply and exhaust spacer, stop valve

**Blank**: No spacer and no stop valve  
**-NPM**: Individual air supply spacer (with M5 female thread for F10)  
**-NP6**: Individual air supply spacer (with φ 6 fitting for F15)  
**-NP8**: Individual air supply spacer (with φ 8 fitting for F15)  
**-NRM**: Individual exhaust spacer (with M5 female thread for F10)  
**-NR6**: Individual exhaust spacer (with φ 6 fitting for F15)  
**-NR8**: Individual exhaust spacer (with φ 8 fitting for F15)  
**-STP**: With stop valve  
 For details, see p. 23, 25.

### Back pressure prevention valve

**Blank**: No back pressure prevention valve  
**-E1**: With back pressure prevention valve<sup>Note6</sup>

### Wiring specification

**-PN**  
 S type plug connector<sup>Note4</sup>

Valve size	Valve units	Manifold type	Wiring specification	Wiring connection specification	Station	Valve size	Valve specification	Manual override	Valve outlet type	Wiring specification	Back pressure prevention valve	Individual air supply and exhaust spacer, stop valve	Voltage
Manifold model					Mounting valve model								
F10M F15M	2 ⋮ □ <sup>Note1</sup>	F FH	-F100N -F101N -F200N -F201N -F260N -D250N <sup>Note9</sup> -D251N <sup>Note9</sup> -D250NU <sup>Note10</sup> -D251NU <sup>Note10</sup>	Blank -W	stn. 1 ⋮ stn. □ <sup>Note2</sup>	F10 F10L F15 F15L	T0 TA T1 TB T2 TC T3 T4 T5	Blank -R <sup>Note3</sup>	-FJ <sup>Note9</sup> -FJ5 <sup>Note9</sup> -FJ6 <sup>Note9</sup> -FM <sup>Note9</sup> -FMH <sup>Note10</sup> -FJ5A <sup>Note9</sup> -FJ5B <sup>Note9</sup> -FJ6A <sup>Note9</sup> -FJ6B <sup>Note9</sup> -FMA <sup>Note9</sup> -FMAH <sup>Note10</sup> -FMB <sup>Note9</sup> -FMBH <sup>Note10</sup>	-PN <sup>Note4</sup>	Blank -E1 <sup>Note6</sup>	Blank -NPM -NP6 -NP8 -NRM -NR6 -NR8 -STP	DC24V DC12V <sup>Note7</sup> AC100V <sup>Note8</sup> AC120V <sup>Note8</sup>
						F10 F15	BP (for block-off plate) <sup>Note5</sup>					Blank -STP	

Notes: 1. For the maximum number of units, see the table for maximum number of valve units by wiring specification, on p. 53.  
 2. Valve mounting location is from the left, with the solenoid on top, and the 4(A), 2(B) ports side in front.  
 3. When the valve specification is T1 or T2, the manual override lever is placed only on the A side.  
 4. Always enter -PN.  
 5. Caution should be exercised that the block-off plate wiring is always double wiring (allocated 2 control pins at 1 stn.), regardless of the wiring connection specification. For single wiring, see p. 53.  
 6. Not available with the individual exhaust spacer.  
 7. Not available in low-current type.  
 8. Not available in low-current type and tandem 3-port valves. In addition, only available when the wiring specification is a D-sub connector.  
 9. Can be selected only when the manifold type is F.  
 10. Can be selected only when the manifold type is FH.

Remark: The external pilot type valve cannot be mounted on the F type manifold.

**Gasket (gasket and exhaust valve)**

F  Z - GS1

Valve size  
 10: 10 mm [0.394 in.] width  
 15: 15 mm [0.591 in.] width

**Block-off plate (block-off plate and 2 mounting screws)**

F  BP

Valve size  
 10: 10 mm [0.394 in.] width  
 15: 15 mm [0.591 in.] width

**Back pressure prevention valve (for monoblock type, 2 pieces)**

F  Z - E1

Valve size  
 10: 10 mm [0.394 in.] width  
 15: 15 mm [0.591 in.] width

**Individual air supply and exhaust spacer (Spacer for non-plug-in type, gasket, exhaust valve, and 2 mounting screws)**

F  Z -

Valve size  
 10: 10 mm [0.394 in.] width  
 15: 15 mm [0.591 in.] width

**Specification**  
 NPM : Individual air supply spacer (with M5 female thread for F10)  
 NP6 : Individual air supply spacer (with φ 6 fitting for F15)  
 NP8 : Individual air supply spacer (with φ 8 fitting for F15)  
 NRM : Individual exhaust spacer (with M5 female thread for F10)  
 NR6 : Individual exhaust spacer (with φ 6 fitting for F15)  
 NR8 : Individual exhaust spacer (with φ 8 fitting for F15)

※For details, see p. 25.

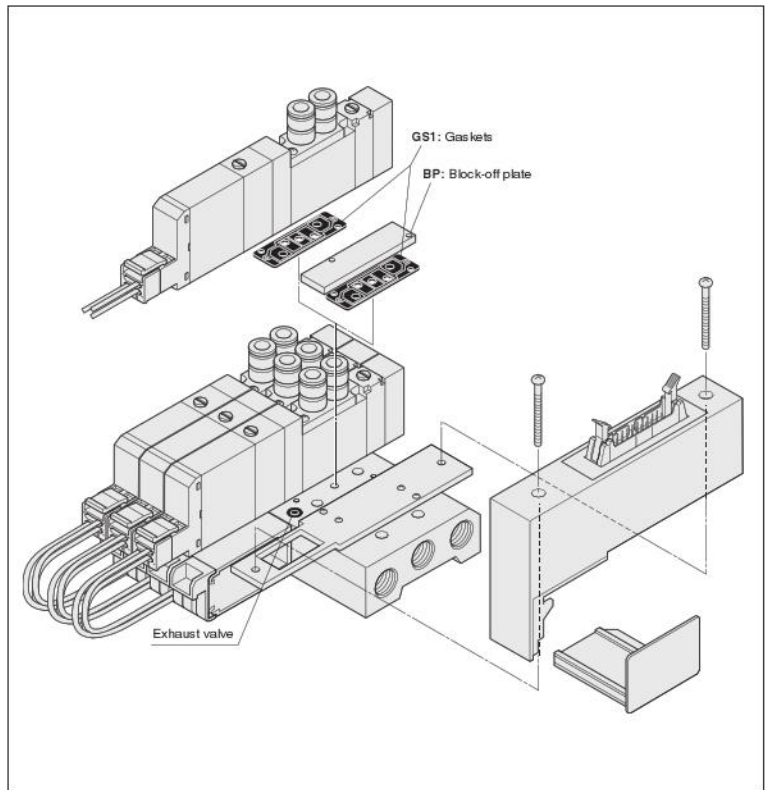

**Muffler**

KM - J

**Fitting size**  
 6: Outer diameter φ 6 (for individual exhaust spacer)  
 8: Outer diameter φ 8 (for individual exhaust spacer)  
 (Sales unit: Set of 10 mufflers)

**Manifold Order Code Example**  
 (4 units of F10 Series)  
**F10M4F-F201**  
 stn.1~2 F10T0-FJ5-PN DC24V  
 stn.3 F10T2-FJ6-PN DC24V  
 stn.4 F10BP  
 Note: This order code example has no relationship to the illustration at upper right.

**Table for maximum number of valve units by wiring specification**

Wiring specification		Maximum number of units	
		Wiring connection specification	
Wiring specification	Max. outputs	Packed wiring (Blank)	Double wiring (-W)
F100N Flat cable (10P)	8	Varies depending on the number of mounted single solenoids, double solenoids, and block-off plates. The number of controlled solenoids should be designated as the maximum number of outputs or less.	4 units
F101N Flat cable (10P)	8		4 units
F200N Flat cable (20P)	16		8 units
F201N Flat cable (20P)	16		8 units
F260N Flat cable (26P)	20		10 units
D250N <input type="checkbox"/> D-sub connector (25P)	16		8 units
D251N <input type="checkbox"/> D-sub connector (25P)	20	10 units	

**Precautions for Order Codes**

- **Orders for valves only**  
 Place orders from "Single Valve Unit Order Codes" on p. 44.  
 Select from valve outlet types -FJ, -FJ5, -FJ6, -FM , -FJ5A, -FJ5B, -FJ6A, -FJ6B, -FMA , or -FMB .
- **Wiring connection specification**  
**Blank** (packed wiring): Wired to match the specifications of the mounted valve.  
**-W** (double wiring): Wiring is always for the double solenoid, regardless of the specifications of the mounted valve.

**Caution**

Caution should be exercised that the block-off plate wiring is always double wiring (allocated 2 control pins at 1 stn.), regardless of the wiring connection specification. The block-off plate wiring can be made as wiring for a single solenoid. Add **-1W** to the end of the block-off plate order code in the case. For details, consult us.

ORDER CODES

# F10, F15 Series PC Board Manifold A Type (Base Piping Type) Order Codes

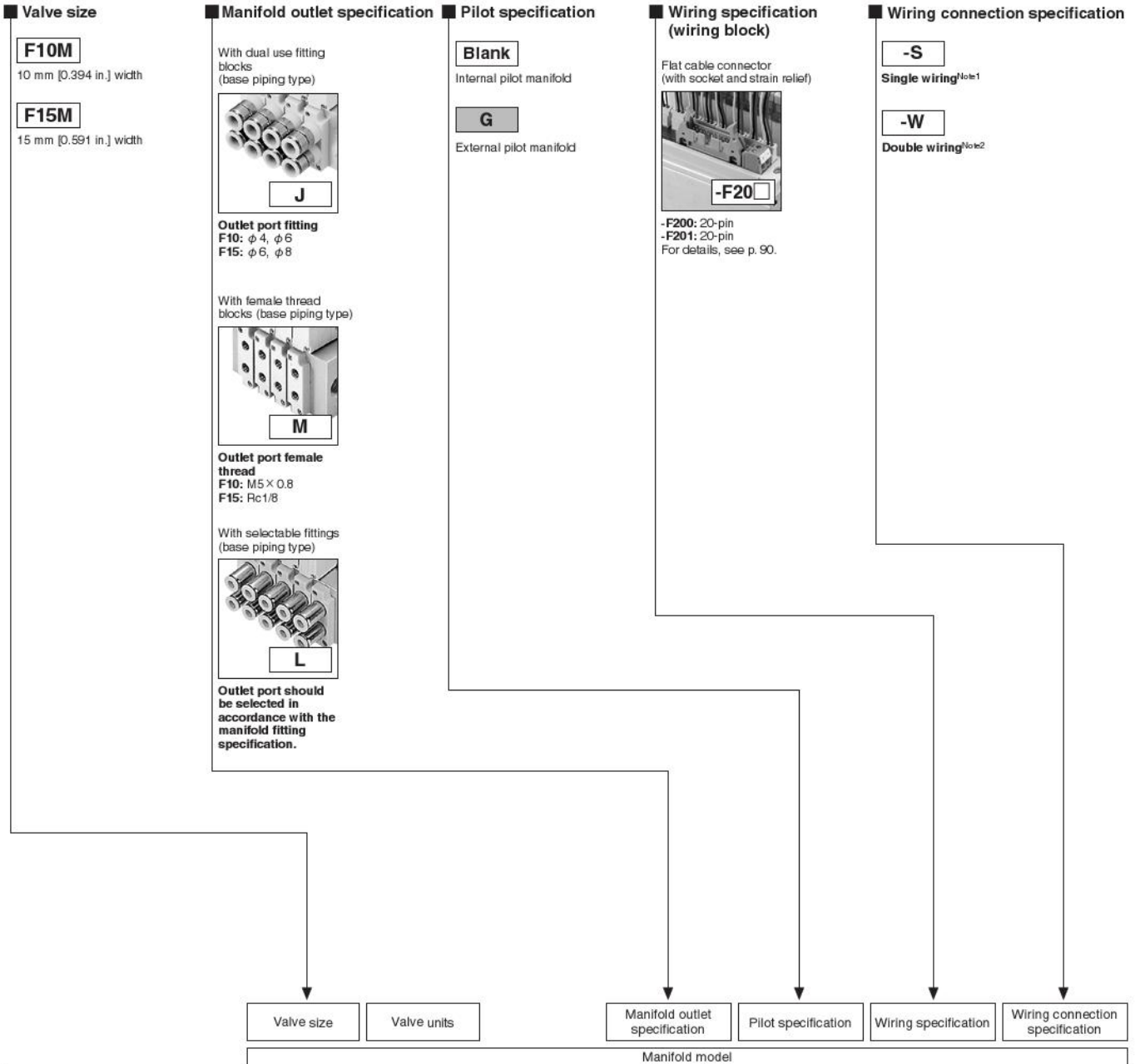

		Manifold model					
		Valve size	Valve units	Manifold outlet specification	Pilot specification	Wiring specification	Wiring connection specification
Single wiring type <sup>Note1</sup>	F10M	6 8 10 12 14 16 <small>Note3</small>	AP	J M	Blank G	-F200 -F201	-S
	F15M	6 8 <small>Note3</small>	AP	L	Blank G	-F200 -F201	-S
Double wiring type <sup>Note2</sup>	F10M	6 8 <small>Note3</small>	AP	J M	Blank G	-F200 -F201	-W
	F15M	6 8 <small>Note3</small>	AP	L	Blank G	-F200 -F201	-W

Notes: 1. Wiring is for the single solenoid only. Note that this is not the same as packed wiring. The mounting valves are limited to single solenoid only (T0, T1 specifications). Therefore, even if the T1 specification valve is switched over to a double solenoid, no power will be applied to the B side solenoid.  
2. Wiring is always for the double solenoid, regardless of the specifications of the mounted valves.  
3. In terms of wiring connection specifications, the number of units for single wiring is 6-16 (even numbers only) and for double wiring is 6 or 8.

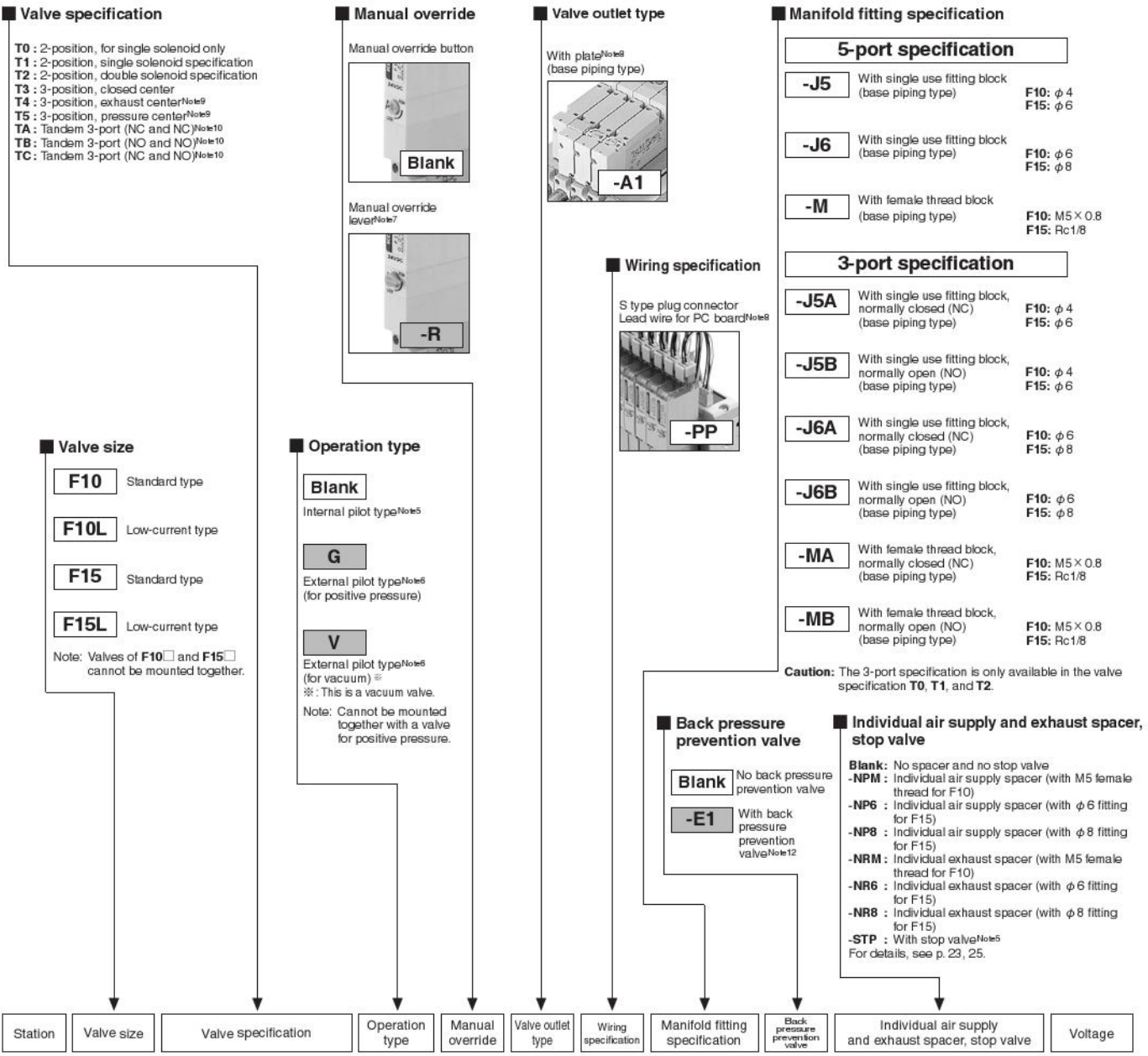

Station	Valve size	Valve specification	Operation type	Manual override	Valve outlet type	Wiring specification	Manifold fitting specification	Back pressure prevention valve	Individual air supply and exhaust spacer, stop valve	Voltage
stn. 1 : : stn. □ Note4	F10 F10L F15 F15L	T0 T1 Note1	Blank <sup>Note5</sup> G <sup>Note6</sup> V <sup>Note6</sup>	Blank -R <sup>Note7</sup>	-A1 <sup>Note8</sup>	-PP <sup>Note8</sup>		Blank -E1 <sup>Note12</sup>	Blank -NPM -NP6 -NP8 -NRM -NR6 -NR8 -STP <sup>Note5</sup>	DC24V DC12V <sup>Note13</sup>
Mounting valve model										
BPC (for block-off plate)										
stn. 1 : : stn. □ Note4	F10 F10L F15 F15L	T0 T1 Note1	Blank <sup>Note5</sup> G <sup>Note6</sup> V <sup>Note6</sup>	Blank -R <sup>Note7</sup>	-A1 <sup>Note8</sup>	-PP <sup>Note8</sup>	-J5 -J6 -M -J5A -J5B -J6A -J6B -MA -MB	Blank -E1 <sup>Note12</sup>	Blank -NPM -NP6 -NP8 -NRM -NR6 -NR8 -STP <sup>Note5</sup>	DC24V DC12V <sup>Note13</sup>
BPC (for block-off plate)										
stn. 1 : : stn. □ Note4	F10 F10L F15 F15L	T0 T3 TA <sup>Note10</sup> T1 T4 <sup>Note9</sup> TB <sup>Note10</sup> T2 T5 <sup>Note9</sup> TC <sup>Note10</sup>	Blank <sup>Note5</sup> G <sup>Note6</sup> V <sup>Note6</sup>	Blank -R <sup>Note7</sup>	-A1 <sup>Note8</sup>	-PP <sup>Note8</sup> Note11		Blank -E1 <sup>Note12</sup>	Blank -NPM -NP6 -NP8 -NRM -NR6 -NR8 -STP <sup>Note5</sup>	DC24V DC12V <sup>Note13</sup>
BPC (for block-off plate)										
stn. 1 : : stn. □ Note4	F10 F10L F15 F15L	T0 T3 TA <sup>Note10</sup> T1 T4 <sup>Note9</sup> TB <sup>Note10</sup> T2 T5 <sup>Note9</sup> TC <sup>Note10</sup>	Blank <sup>Note5</sup> G <sup>Note6</sup> V <sup>Note6</sup>	Blank -R <sup>Note7</sup>	-A1 <sup>Note8</sup>	-PP <sup>Note8</sup> Note11	-J5 -J6 -M -J5A -J5B -J6A -J6B -MA -MB	Blank -E1 <sup>Note12</sup>	Blank -NPM -NP6 -NP8 -NRM -NR6 -NR8 -STP <sup>Note5</sup>	DC24V DC12V <sup>Note13</sup>
BPC (for block-off plate)										

Notes: 4. Valve mounting location is from the left, with the solenoid on top, and the 4(A), 2(B) ports side in front.  
 5. Cannot be mounted on the external pilot manifold.  
 6. Cannot be mounted on the internal pilot manifold.  
 7. When the valve specification is T1 or T2, the manual override lever is placed only on the A side.  
 8. Always enter -A1 and -PP.  
 9. Not available in the vacuum valves.  
 10. Not available in external pilot type and vacuum valves.  
 11. The lead wire on the solenoid B side (white) is not available in valve specification T0.  
 12. Not available with the individual exhaust spacer and vacuum valve.  
 13. Not available in low-current type.

**Gasket (gasket and exhaust valve)**

F  Z - GS1

Valve size  
 10: 10 mm [0.394 in.] width  
 15: 15 mm [0.591 in.] width

**Block-off plate (block-off plate, 2 mounting screws, and housing)**

F  BPC

Valve size  
 10: 10 mm [0.394 in.] width  
 15: 15 mm [0.591 in.] width

**Connector-related order codes**

JAZ  -

Valve specification

Blank: For T1, T2, T3, T4, T5, TA, TB, TC  
 0: For T0

Connector specification

P10: For F10 series  
 Connector lead wire for PC board manifold  
 P15: For F15 series  
 Connector lead wire for PC board manifold

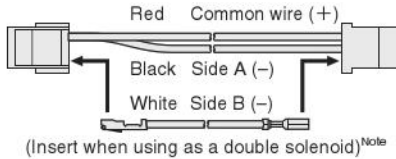

Note: White lead wire is not available for JAZ0-P.

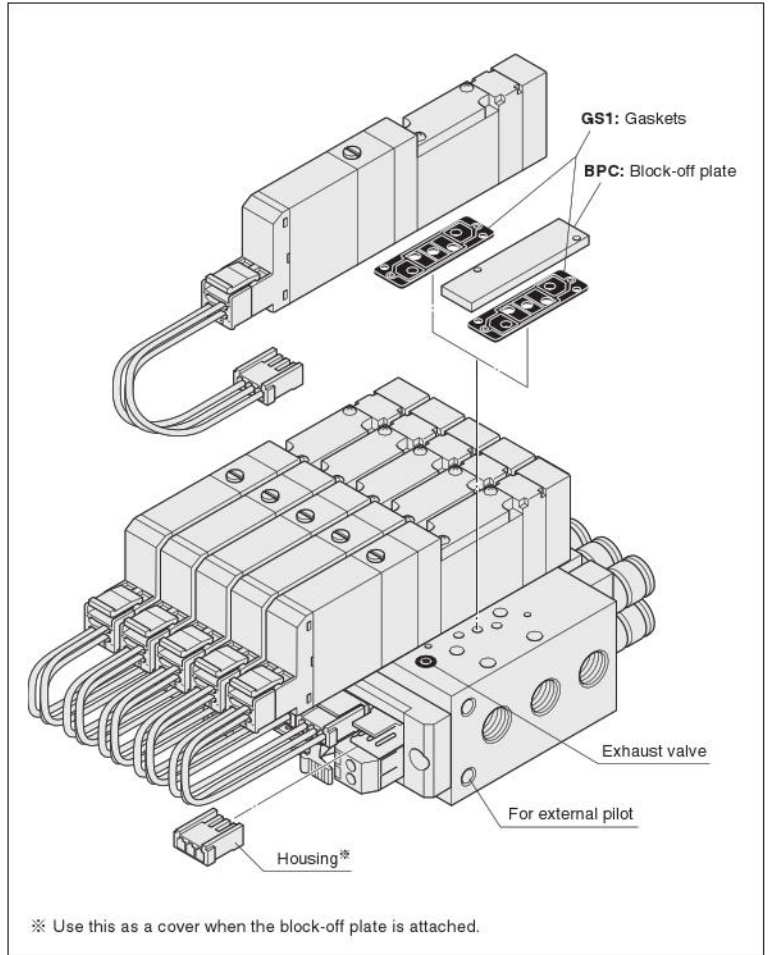

**Back pressure prevention valve (for monoblock type, 2 pieces)**

F  Z - E1

Valve size  
 10: 10 mm [0.394 in.] width  
 15: 15 mm [0.591 in.] width

**Individual air supply and exhaust spacer (Spacer for non-plug-in type, gasket, exhaust valve, and 2 mounting screws)**

F  Z -

Valve size  
 10: 10 mm [0.394 in.] width  
 15: 15 mm [0.591 in.] width

Specification  
 NPM: Individual air supply spacer (with M5 female thread for F10)  
 NP6: Individual air supply spacer (with  $\phi$  6 fitting for F15)  
 NP8: Individual air supply spacer (with  $\phi$  8 fitting for F15)  
 NRM: Individual exhaust spacer (with M5 female thread for F10)  
 NR6: Individual exhaust spacer (with  $\phi$  6 fitting for F15)  
 NR8: Individual exhaust spacer (with  $\phi$  8 fitting for F15)

※ For details, see p. 25.

**Manifold Order Code Example (8 units of F10 Series)**

**F10M8APL-F201-W**

stn.1~4 F10T0-A1-PP-J5 DC24V  
 stn.5~7 F10T2-A1-PP-J6 DC24V  
 stn.8 F10BPC-J6

Note: This order code example has no relationship to the illustration at upper right.

**Muffler**

KM - J

Fitting size  
 6: Outer diameter  $\phi$  6 (for individual exhaust spacer)  
 8: Outer diameter  $\phi$  8 (for individual exhaust spacer)  
 (Sales unit: Set of 10 mufflers)

**Precautions for Order Codes**

● Orders for valves only

Enter the code  Valve size  Valve specification  Pilot specification  Manual override -  Valve outlet type - **PP**  Voltage to order.

● Wiring connection specification

-S (single wiring): Wiring for single solenoid only.  
 -W (double wiring): Wiring is always for the double solenoid, regardless of the specifications of the mounted valve.

When the lead wire for the PC board is not required, enter **-PN**.



# F10, F15 Series PC Board Manifold F Type (Direct Piping Type) Order Codes

## Valve size

### F10M

10 mm [0.394 in.] width

### F15M

15 mm [0.591 in.] width

## Wiring specification (wiring block)

Flat cable connector (with socket and strain relief)

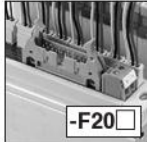

-F200: 20-pin  
-F201: 20-pin  
For details, see p. 90.

## Wiring connection specification

- S Single wiring<sup>Note1</sup>
- W Double wiring<sup>Note2</sup>

## Valve size

- F10 Standard type
- F10L Low-current type
- F15 Standard type
- F15L Low-current type

Note: Valves of F10□ and F15□ cannot be mounted together.

## Manual override

Manual override button



Manual override lever<sup>Note5</sup>



## Valve outlet type

### 5-port specification

- FJ With dual use fitting block (direct piping type) F10: φ 4, φ 6 F15: φ 6, φ 8
- FJ5 With single use fitting block (direct piping type) F10: φ 4 F15: φ 6
- FJ6 With single use fitting block (direct piping type) F10: φ 6 F15: φ 8
- FM With female thread block (direct piping type) F10: M5 × 0.8 F15: Rc1/8

### 3-port specification

- FJ5A With single use fitting block, normally closed (NC) (direct piping type) F10: φ 4 F15: φ 6
- FJ5B With single use fitting block, normally open (NO) (direct piping type) F10: φ 4 F15: φ 6
- FJ6A With single use fitting block, normally closed (NC) (direct piping type) F10: φ 6 F15: φ 8
- FJ6B With single use fitting block, normally open (NO) (direct piping type) F10: φ 6 F15: φ 8
- FMA With female thread block, normally closed (NC) (direct piping type) F10: M5 × 0.8 F15: Rc1/8
- FMB With female thread block, normally open (NO) (direct piping type) F10: M5 × 0.8 F15: Rc1/8

Caution: The 3-port specifications are only available in the valve specification T0, T1, and T2.

## Wiring specification

S type plug connector  
Lead wire for PC board

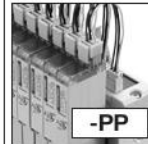

## Individual air supply and exhaust spacer, stop valve

- Blank: No spacer and no stop valve
  - NPM: Individual air supply spacer (with M5 female thread for F10)
  - NP6: Individual air supply spacer (with φ 6 fitting for F15)
  - NP8: Individual air supply spacer (with φ 8 fitting for F15)
  - NRM: Individual exhaust spacer (with M5 female thread for F10)
  - NR6: Individual exhaust spacer (with φ 6 fitting for F15)
  - NR8: Individual exhaust spacer (with φ 8 fitting for F15)
  - STP: With stop valve
- For details, see p. 23, 25.

## Back pressure prevention valve

- Blank: No back pressure prevention valve
- E1: With back pressure prevention valve<sup>Note8</sup>

Valve size	Valve units	Wiring specification	Wiring connection specification	Station	Valve size	Valve specification	Manual override	Valve outlet type	Wiring specification	Back pressure prevention valve	Individual air supply and exhaust spacer, stop valve	Voltage
------------	-------------	----------------------	---------------------------------	---------	------------	---------------------	-----------------	-------------------	----------------------	--------------------------------	--	---------

Manifold model				Mounting valve model												
Single wiring type <sup>Note1</sup>	F10M	6 8 10 12 14 16 <sup>Note3</sup>	FP	-F200 -F201	-S	stn. 1 : stn. □ <sup>Note4</sup>	F10	T0	Blank	-FJ	-FJ5B	-PP <sup>Note6</sup>	Blank	-NPM	-NRM	DC24V
							F10L	T1 <sup>Note1</sup>	-R <sup>Note5</sup>	-FJ5	-FJ6A					
Double wiring type <sup>Note2</sup>	F15M	6 8 <sup>Note3</sup>	FP	-F200 -F201	-W	stn. 1 : stn. □ <sup>Note4</sup>	F10	T0 T3 TA	Blank	-FJ	-FJ5B	-PP <sup>Note6</sup> <sup>Note7</sup>	Blank	-NPM	-NRM	DC24V
							F10L	T1 T4 TB		-R <sup>Note5</sup>	-FJ5					
							F15	T2 T5 TC	-FM	-FMA			-NP8	-NR8	DC12V <sup>Note9</sup>	
							F15L		-FJ6	-FJ6B			-STP			
							F10 F15	BPC (for block-off plate)					Blank	-STP		

- Notes: 1. Wiring is for the single solenoid only. Note that this is not the same as packed wiring. The mounting valves are limited to single solenoid only (T0, T1 specifications). Therefore, even if the T1 specification valve is switched over to a double solenoid, no power will be applied to the B side solenoid.
2. Wiring is always for the double solenoid, regardless of the specifications of the mounted valve.
3. In terms of wiring connection specifications, the number of units for single wiring is 6-16 (even numbers only) and for double wiring is 6 or 8.
4. Valve mounting location is from the left, with the solenoid on top, and the 4(A), 2(B) ports side in front.
5. When the valve specification is T1 or T2, the manual override lever is placed only on the A side.
6. Always enter -PP.
7. The lead wire on the solenoid B side (white) is not available in valve specification T0.
8. Not available with the individual exhaust spacer.
9. Not available in low-current type.

**Gasket (gasket and exhaust valve)**

F  Z - GS1

Valve size  
 10: 10 mm [0.394 in.] width  
 15: 15 mm [0.591 in.] width

**Block-off plate (block-off plate, 2 mounting screws, and housing)**

F  BPC

Valve size  
 10: 10 mm [0.394 in.] width  
 15: 15 mm [0.591 in.] width

**Connector-related order code**

JAZ  -

Valve specification  
 Blank: For T1, T2, T3, T4, T5, TA, TB, TC  
 0: For T0

Connector specification  
 P10: For F10 series  
 Connector lead wire for PC board manifold  
 P15: For F15 series  
 Connector lead wire for PC board manifold

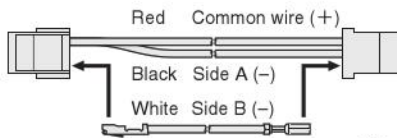

Note: White lead wire is not available for JAZ0-P.

**Back pressure prevention valve (for monoblock type, 2 pieces)**

F  Z - E1

Valve size  
 10: 10 mm [0.394 in.] width  
 15: 15 mm [0.591 in.] width

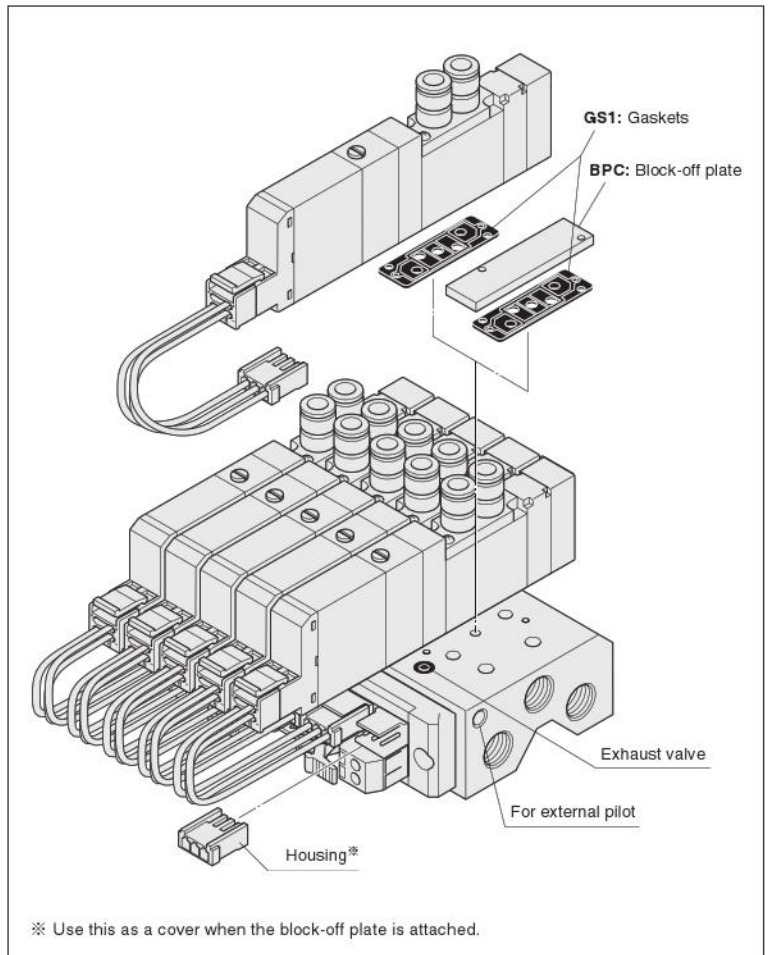

※ Use this as a cover when the block-off plate is attached.

**Individual air supply and exhaust spacer (Spacer for non-plug-in type, gasket, exhaust valve, and 2 mounting screws)**

F  Z -

Valve size  
 10: 10 mm [0.394 in.] width  
 15: 15 mm [0.591 in.] width

Specification  
 NPM: Individual air supply spacer (with M5 female thread for F10)  
 NP6: Individual air supply spacer (with  $\phi 6$  fitting for F15)  
 NP8: Individual air supply spacer (with  $\phi 8$  fitting for F15)  
 NRM: Individual exhaust spacer (with M5 female thread for F10)  
 NR6: Individual exhaust spacer (with  $\phi 6$  fitting for F15)  
 NR8: Individual exhaust spacer (with  $\phi 8$  fitting for F15)

※For details, see p. 25.

**Manifold Order Code Example**

(8 units of F10 Series)  
**F10M8FP-F201-W**  
 stn.1~4 F10T0-FJ5-PP DC24V  
 stn.5~7 F10T2-FJ6-PP DC24V  
 stn.8 F10BPC

Note: This order code example has no relationship to the illustration at upper right.

**Muffler**

KM - J

Fitting size  
 6: Outer diameter  $\phi 6$  (for individual exhaust spacer)  
 8: Outer diameter  $\phi 8$  (for individual exhaust spacer)  
 (Sales unit: Set of 10 mufflers)

**Precautions for Order Codes**

● **Orders for valves only**

Enter the code  Valve size  Valve specification  Manual override -  Valve outlet type -  PP  Voltage  to order.

● **Wiring connection specification**

-S (single wiring): Wiring for single solenoid only.  
 -W (double wiring): Wiring is always for the double solenoid, regardless of the specifications of the mounted valve.

When the lead wire for the PC board is not required, enter -PN.

ORDER CODES

# F10, F15 Series Split Manifold Non-Plug-in Type Order Codes

## Valve size

- F10M** 10 mm [0.394 in.] width
- F15M** 15 mm [0.591 in.] width

## Manifold outlet specification

With dual use fitting blocks (base piping type)

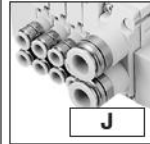

**Outlet port fitting**  
**F10:** φ 4, φ 5  
**F15:** φ 6, φ 8

With selectable fittings (base piping type)

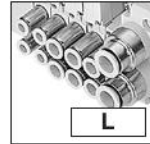

**Outlet port should be selected in accordance with the manifold fitting specification.**

With female thread blocks (base piping type)

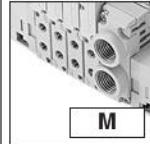

**Outlet port female thread**  
**F10:** M5 × 0.8  
**F15:** Rc1/8

With plates (direct piping type)

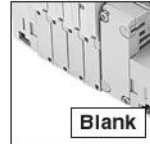

## Pilot specification

**Blank**

Internal pilot manifold

**G**

External pilot manifold

## Piping block specification (air supply and exhaust)

### Fitting block

- JR** : Dual use fitting, right-side mounting<sup>Note11</sup>
  - JL** : Dual use fitting, left-side mounting<sup>Note11</sup>
  - JD** : Dual use fitting, both-side mounting<sup>Note11</sup>
- Fitting size (1(P), 3, 5(R) ports), φ 8, φ 10

### Female thread block

- MR** : Female thread, right-side mounting<sup>Note11</sup>
  - ML** : Female thread, left-side mounting<sup>Note11</sup>
  - MD** : Female thread, both-side mounting<sup>Note11</sup>
- Female thread size (1(P), 3, 5(R) ports), Rc1/4

### Female thread block

- MRH** : Female thread, right-side mounting<sup>Note12</sup>
  - MLH** : Female thread, left-side mounting<sup>Note12</sup>
  - MDH** : Female thread, both-side mounting<sup>Note12</sup>
- Female thread size (1(P), 3, 5(R) ports), NPT1/4

### Single use fitting block

- J5R** : Single use fitting, right-side mounting<sup>Note11</sup>
  - J5L** : Single use fitting, left-side mounting<sup>Note11</sup>
  - J5D** : Single use fitting, both-side mounting<sup>Note11</sup>
- Fitting size (1(P), 3, 5(R) ports), φ 8
- J6R** : Single use fitting, right-side mounting<sup>Note11</sup>
  - J6L** : Single use fitting, left-side mounting<sup>Note11</sup>
  - J6D** : Single use fitting, both-side mounting<sup>Note11</sup>
- Fitting size (1(P), 3, 5(R) ports), φ 10

## Valve size

- F10** Standard type
- F10L** Low-current type
- F15** Standard type
- F15L** Low-current type

Note: Valves of **F10□** and **F15□** cannot be mounted together.

Valve size	Valve units	Manifold type	Manifold outlet specification	Pilot specification	Piping block specification
Manifold model					

Base piping type	F10M F15M	2 ⋮ 20	N	J M	Blank G	-JR -JL -JD -MR -ML -MD	-J5R -J6R -J5L -J6L -J5D -J6D
Base piping type selectable fitting			N	L	Blank G	-JR <sup>Note11</sup> -JL <sup>Note11</sup> -JD <sup>Note11</sup> -MR <sup>Note11</sup> -ML <sup>Note11</sup> -MD <sup>Note11</sup> -MRH <sup>Note12</sup> -MLH <sup>Note12</sup>	-MDH <sup>Note12</sup> -J5R <sup>Note11</sup> -J6R <sup>Note11</sup> -J5L <sup>Note11</sup> -J6L <sup>Note11</sup> -J5D <sup>Note11</sup> -J6D <sup>Note11</sup>
Direct piping type			NH	Blank	Blank G	-JR <sup>Note11</sup> -JL <sup>Note11</sup> -JD <sup>Note11</sup> -MR <sup>Note11</sup> -ML <sup>Note11</sup> -MD <sup>Note11</sup> -MRH <sup>Note12</sup> -MLH <sup>Note12</sup>	-MDH <sup>Note12</sup> -J5R <sup>Note11</sup> -J6R <sup>Note11</sup> -J5L <sup>Note11</sup> -J6L <sup>Note11</sup> -J5D <sup>Note11</sup> -J6D <sup>Note11</sup>

Remark: Negative common specifications are also available as made to order products (add **-129W** to the ends of the valve and manifold model order codes). For details, consult us.

- Valve specification**
- T0 : 2-position, for single solenoid only
  - T1 : 2-position, single solenoid specification
  - T2 : 2-position, double solenoid specification
  - T3 : 3-position, closed center
  - T4 : 3-position, exhaust center
  - T5 : 3-position, pressure center
  - TA : Tandem 3-port (NC and NO)<sup>Note7</sup>
  - TB : Tandem 3-port (NO and NO)<sup>Note7</sup>
  - TC : Tandem 3-port (NC and NO)<sup>Note7</sup>

- Operation type**
- Blank**  
Internal pilot type<sup>Note5</sup>
  - G**  
External pilot type<sup>Note6</sup>  
(for positive pressure)  
\* No vacuum valve can be mounted.



- Valve outlet type**
- A1** With plate<sup>Note3</sup>  
(base piping type)
- 5-port specification**
- FJ** With dual use fitting block<sup>Note11</sup>  
(direct piping type) F10: φ4, φ6 F15: φ6, φ8
  - FJ5** With single use fitting block<sup>Note11</sup>  
(direct piping type) F10: φ4 F15: φ6
  - FJ6** With single use fitting block<sup>Note11</sup>  
(direct piping type) F10: φ6 F15: φ8
  - FM** With female thread block<sup>Note11</sup>  
(direct piping type) F10: M5 × 0.8 F15: Rc1.8
  - FMH** With female thread block<sup>Note12</sup>  
(direct piping type) F10: 10-32UNF F15: NPT1.8

- 3-port specification**
- FJ5A** With single use fitting block, normally closed (NC)<sup>Note11</sup> F10: φ4 F15: φ6
  - FJ5B** With single use fitting block, normally open (NO)<sup>Note11</sup> F10: φ4 F15: φ6
  - FJ6A** With single use fitting block, normally closed (NC)<sup>Note11</sup> F10: φ6 F15: φ8
  - FJ6B** With single use fitting block, normally open (NO)<sup>Note11</sup> F10: φ6 F15: φ8
  - FMA** With female thread block, normally closed (NC)<sup>Note11</sup> F10: M5 × 0.8 F15: Rc1.8
  - FMAH** With female thread block, normally closed (NC)<sup>Note12</sup> F10: 10-32UNF F15: NPT1.8
  - FMB** With female thread block, normally open (NO)<sup>Note11</sup> F10: M5 × 0.8 F15: Rc1.8
  - FMBH** With female thread block, normally open (NO)<sup>Note12</sup> F10: 10-32UNF F15: NPT1.8
- Caution:** The 3-port specifications are only available in the valve specification T0, T1, and T2.

- Wiring specification**
- S type plug connector  
Without connector
  - PN**
  - S type plug connector  
Lead wire 300 mm [11.8 in.]
  - PS**
  - S type plug connector  
Lead wire 3000 mm [118 in.]
  - PS3**
  - Pre-wired positive common terminal  
S type plug connector  
Lead wire 300 mm [11.8 in.]
  - CPS**
  - Pre-wired positive common terminal  
S type plug connector  
Lead wire 3000 mm [118 in.]
  - CPS3**

- Manifold fitting specification**
- 5-port specification**
- J5** With single use fitting block<sup>Note11</sup>  
(base piping type) F10: φ4 F15: φ6
  - J6** With single use fitting block<sup>Note11</sup>  
(base piping type) F10: φ6 F15: φ8
  - M** With female thread block<sup>Note11</sup>  
(base piping type) F10: M5 × 0.8 F15: Rc1.8
  - MH** With female thread block<sup>Note12</sup>  
(base piping type) F10: 10-32UNF F15: NPT1.8

- 3-port specification**
- J5A** With single use fitting block, normally closed (NC)<sup>Note11</sup> F10: φ4 F15: φ6
  - J5B** With single use fitting block, normally open (NO)<sup>Note11</sup> F10: φ4 F15: φ6
  - J6A** With single use fitting block, normally closed (NC)<sup>Note11</sup> F10: φ6 F15: φ8
  - J6B** With single use fitting block, normally open (NO)<sup>Note11</sup> F10: φ6 F15: φ8
  - MA** With female thread block, normally closed (NC)<sup>Note11</sup> F10: M5 × 0.8 F15: Rc1.8
  - MAH** With female thread block, normally closed (NC)<sup>Note12</sup> F10: 10-32UNF F15: NPT1.8
  - MB** With female thread block, normally open (NO)<sup>Note11</sup> F10: M5 × 0.8 F15: Rc1.8
  - MBH** With female thread block, normally open (NO)<sup>Note12</sup> F10: 10-32UNF F15: NPT1.8

- Port isolator**
- Blank** : No port isolator
  - SP** : For 1(P) port<sup>Note4</sup>
  - SR** : For 3(R2), 5(R1) ports<sup>Note4</sup>
  - SA** : For 1(P), 3(R2), and 5(R1) ports<sup>Note4</sup>
- Back pressure prevention valve**
- Blank** : No back pressure prevention valve
  - E2** : With back pressure prevention valve<sup>Note8</sup>

- Individual air supply and exhaust spacer**
- Blank** : No spacer
  - NPM** : Individual air supply spacer (with M5 female thread for F10)
  - NP6** : Individual air supply spacer (with φ6 fitting for F15)
  - NP8** : Individual air supply spacer (with φ8 fitting for F15)
  - NRM** : Individual exhaust spacer (with M5 female thread for F10)
  - RP6** : Individual exhaust spacer (with φ6 fitting for F15)
  - RP8** : Individual exhaust spacer (with φ8 fitting for F15)
- For details, see p. 25.

Station	Valve size	Valve specification	Operation type	IP specification	Manual override	Valve outlet type	Wiring specification	Manifold fitting specification	Back pressure prevention valve	Individual air supply and exhaust spacer	Port isolator	Voltage
Mounting valve model												
stn. 1 ⋮ stn. □ <small>Note 1</small>	F10 F10L F15 F15L	T0 T1 T2 T3 T4 T5 TA <sup>Note7</sup> TB <sup>Note7</sup> TC <sup>Note7</sup>	Blank <sup>Note5</sup> G <sup>Note6</sup>	Blank	Blank	-A1 <sup>Note3</sup>	-PN -PS -PS3 -CPS -CPS3		Blank -E2 <sup>Note8</sup>	Blank -NPM -NRM -NP6 -NR6 -NP8 -NR8	Blank -SP <sup>Note4</sup> -SR <sup>Note4</sup> -SA <sup>Note4</sup>	DC24V DC12V <sup>Note9</sup> AC100V <sup>Note10</sup> AC120V <sup>Note10</sup>
BPN (for block-off plate)												
stn. 1 ⋮ stn. □ <small>Note 1</small>	F10 F10L F15 F15L	T0 T1 T2 T3 T4 T5 TA <sup>Note7</sup> TB <sup>Note7</sup> TC <sup>Note7</sup>	Blank <sup>Note5</sup> G <sup>Note6</sup>	Blank	Blank	-A1 <sup>Note3</sup>	-PN -PS -PS3 -CPS -CPS3	-J5 <sup>Note11</sup> -J6A <sup>Note11</sup> -J6 <sup>Note11</sup> -J6B <sup>Note11</sup> -M <sup>Note11</sup> -MA <sup>Note11</sup> -MH <sup>Note12</sup> -MAH <sup>Note12</sup> -J5A <sup>Note11</sup> -MB <sup>Note11</sup> -J5B <sup>Note11</sup> -MBH <sup>Note12</sup>	Blank -E2 <sup>Note8</sup>	Blank -NPM -NRM -NP6 -NR6 -NP8 -NR8	Blank -SP <sup>Note4</sup> -SR <sup>Note4</sup> -SA <sup>Note4</sup>	DC24V DC12V <sup>Note9</sup> AC100V <sup>Note10</sup> AC120V <sup>Note10</sup>
BPN (for block-off plate)												
stn. 1 ⋮ stn. □ <small>Note 1</small>	F10 F10L F15 F15L	T0 T1 T2 T3 T4 T5 TA <sup>Note7</sup> TB <sup>Note7</sup> TC <sup>Note7</sup>	Blank <sup>Note5</sup> G <sup>Note6</sup>	Blank	Blank	-A1 <sup>Note3</sup>	-PN -PS -PS3 -CPS -CPS3	-FJ <sup>Note11</sup> -FJ6A <sup>Note11</sup> -FJ5 <sup>Note11</sup> -FJ6B <sup>Note11</sup> -FM <sup>Note11</sup> -FMA <sup>Note11</sup> -FMH <sup>Note12</sup> -FMAH <sup>Note12</sup> -FJ5A <sup>Note11</sup> -FMB <sup>Note11</sup> -FJ5B <sup>Note11</sup> -FMBH <sup>Note12</sup>	Blank -E2 <sup>Note8</sup>	Blank -NPM -NRM -NP6 -NR6 -NP8 -NR8	Blank -SP <sup>Note4</sup> -SR <sup>Note4</sup> -SA <sup>Note4</sup>	DC24V DC12V <sup>Note9</sup> AC100V <sup>Note10</sup> AC120V <sup>Note10</sup>
BPN (for block-off plate)												

Notes: 1. Valve mounting location is from the left, with the solenoid on top, and the 4(A), 2(B) ports side in front.  
 2. When the valve specification is T1 or T2, the manual override lever is placed only on the A side.  
 3. When selecting J, M, or L (base piping type) for the manifold outlet specification, always enter -A1 (with plate) for the valve outlet type.  
 4. Port isolators can be installed only when piping blocks are mounted on both sides. In addition, only 1 port isolator can be mounted in 1 manifold for -SA, or 1 each port isolator for -SP and -SR for a total of 2 locations. When shipping, the designated port isolators are mounted between the designated station and the station to its immediate left (the next smaller stn. No.).  
 5. Cannot be mounted on the external pilot manifold.  
 6. Cannot be mounted on the internal pilot manifold.  
 7. Not available in external pilot type.  
 8. Not available with the individual exhaust spacer.  
 9. Not available in low-current type.  
 10. Not available in low-current type and tandem 3-port valves.  
 11. Can be selected only when the manifold type is N.  
 12. Can be selected only when the manifold type is NH.  
 13. IP65 compliant protective construction to protect against intrusion of dust and water from outside.

Parts for manifold



**Valve size**  
 10: 10 mm [0.394 in.] width  
 15: 15 mm [0.591 in.] width

**Parts content**  
**GS2** : Gasket (gasket and exhaust valve)  
**SP** : Port isolator (for 1(P) port)  
**SR** : Port isolator (for 3(R2), 5(R1) ports)  
**SA** : Port isolator (for 1(P), 3(R2), 5(R1) ports)

Piping block assembly



**Valve size**  
 10: 10 mm [0.394 in.] width  
 15: 15 mm [0.591 in.] width

**Piping specification**  
**PJ** : Dual use fitting piping block  
**PJ5** : Single use fitting piping block  $\phi 8$   
**PJ6** : Single use fitting piping block  $\phi 10$   
**PM** : Female thread piping block Rc1/4  
**PMH** : Female thread piping block NPT1/4

**Pilot specification**  
**Blank** : Internal pilot  
**G** : External pilot

Block-off plate (block-off plate, 2 mounting screws, and plug)



**Valve size**  
 10: 10 mm [0.394 in.] width  
 15: 15 mm [0.591 in.] width

For non-plug-in type

Connector-related order codes ※For details, see p. 19.

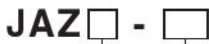

**Valve specification**  
**Blank**: For T1, T2, T3, T4, T5, TA, TB, TC  
 0: For T0

**Connector specification**  
**CP** : Connector, lead wire length 300 mm  
**CP3** : Connector, lead wire length 3000 mm  
**CPN** : Connector without lead wire (short bar, contacts included)  
**PA** : Positive common A type, lead wire length 300 mm \*  
**PA3** : Positive common A type, lead wire length 3000 mm \*  
**PB** : Positive common B type, lead wire length 300 mm \*  
**PB3** : Positive common B type, lead wire length 3000 mm \*  
**PC** : Positive common C type, lead wire length 300 mm \*  
**PC3** : Positive common C type, lead wire length 3000 mm \*

300 mm = 11.8 in.  
 1500 mm = 59 in.  
 3000 mm = 118 in.



**Valve specification**  
 For T1, T2, T3, T4, T5, TA, TB, TC

**Connector specification**  
**CC1.5** : Cabtyre cable, length 1500 mm \*  
**CC3** : Cabtyre cable, length 3000 mm \*

Common connector assembly

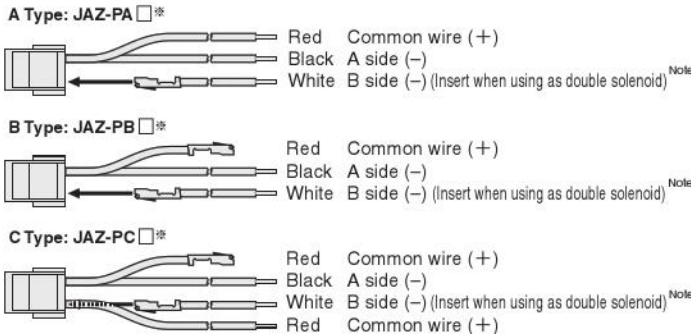

※ Lead wire length **Blank**: 300 mm [11.8 in.] Note: White lead wire is not available with JAZO-P [ ] [ ] .  
 3: 3000 mm [118 in.]

Remark: Connector for negative common type also available. For details, see p. 19.

Valve base assembly (valve base and gasket)



**Valve size**  
 10: 10 mm [0.394 in.] width  
 15: 15 mm [0.591 in.] width

**Piping specification**  
**VJ** : Dual use fitting valve base  
**VJ5** : Single use fitting valve base F10:  $\phi 4$ , F15:  $\phi 6$   
**VJ6** : Single use fitting valve base F10:  $\phi 6$ , F15:  $\phi 8$   
**VJ5A** : 3-port specification normally closed, single use fitting valve base F10:  $\phi 4$ , F15:  $\phi 6$   
**VJ5B** : 3-port specification normally open, single use fitting valve base F10:  $\phi 4$ , F15:  $\phi 6$   
**VJ6A** : 3-port specification normally closed, single use fitting valve base F10:  $\phi 6$ , F15:  $\phi 8$   
**VJ6B** : 3-port specification normally open, single use fitting valve base F10:  $\phi 6$ , F15:  $\phi 8$   
**VM** : Female thread valve base F10: M5  $\times$  0.8, F15: Rc1/8  
**VMA** : 3-port specification normally closed, female thread valve base F10: M5  $\times$  0.8, F15: Rc1/8  
**VMB** : 3-port specification normally open, female thread valve base F10: M5  $\times$  0.8, F15: Rc1/8  
**VMH** : Female thread valve base F10: 10-32UNF, F15: NPT1/8  
**VMAH** : 3-port specification normally closed, female thread valve base F10: 10-32UNF, F15: NPT1/8  
**VMBH** : 3-port specification normally open, female thread valve base F10: 10-32UNF, F15: NPT1/8  
**VP** : Valve base plate

**Pilot specification**  
**Blank** : Internal pilot  
**G** : External pilot

End blocks (one set of left and right)



**Valve size**  
 10: 10 mm [0.394 in.] width  
 15: 15 mm [0.591 in.] width

**Pilot specification**  
**Blank** : Internal pilot  
**G** : External pilot

Back pressure prevention valve (2 pieces for split type, with dedicated gasket)



**Valve size**  
 10: 10 mm [0.394 in.] width  
 15: 15 mm [0.591 in.] width

Individual air supply and exhaust spacer (Spacer for non-plug-in type, gasket, exhaust valve, and 2 mounting screws)



**Valve size**  
 10: 10 mm [0.394 in.] width  
 15: 15 mm [0.591 in.] width

**Specification**  
**NPM** : Individual air supply spacer (with M5 female thread for F10)  
**NP6** : Individual air supply spacer (with  $\phi 6$  fitting for F15)  
**NP8** : Individual air supply spacer (with  $\phi 8$  fitting for F15)  
**NRM** : Individual exhaust spacer (with M5 female thread for F10)  
**NR6** : Individual exhaust spacer (with  $\phi 6$  fitting for F15)  
**NR8** : Individual exhaust spacer (with  $\phi 8$  fitting for F15)

※For details, see p. 25.

Muffler



**Fitting size**  
**6** : Outer diameter  $\phi 6$  (for individual exhaust spacer)  
**8** : Outer diameter  $\phi 8$  (for individual exhaust spacer)  
**10** : Outer diameter  $\phi 10$   
 (Sales unit: Set of 10 mufflers)

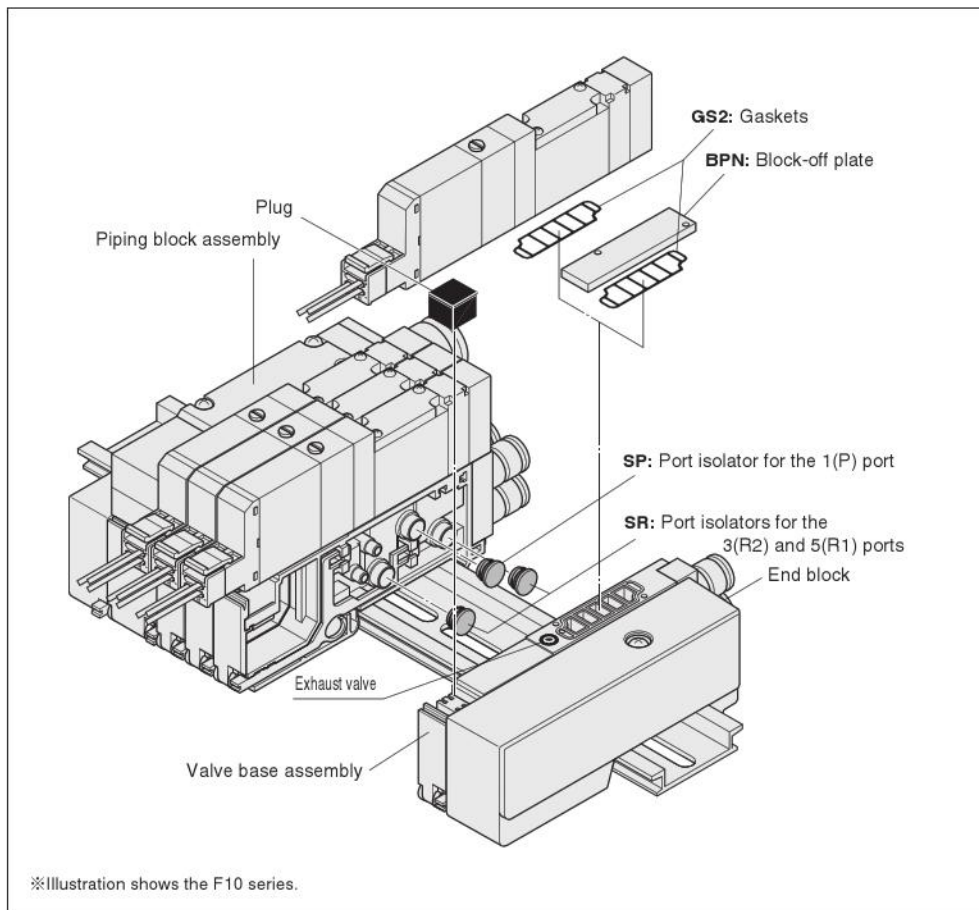

### Manifold Order Code Example

(4 units of F10 Series)

#### F10M4NL-J5R

stn.1~2 F10T0-A1-PS-J5 DC24V  
stn.3 F10T2-A1-PS-J6 DC24V  
stn.4 F10BPN-J6

Note: This order code example has no relationship to the illustration above.

### Precautions for Order Codes

#### ● Orders for valves only

Place orders from "Single Valve Unit Order Codes" on p. 44.

However, **Blank**, **A2**, **F3**, **F4**, **F5**, **F6**, **F4A**, **F4B**, **F5A**, **F5B**, **F6A**, and **F6B** cannot be selected for the valve outlet type. And for the wiring specification, **Blank**, **PL**, and **PL3** cannot be selected. In addition, for common terminal wiring connections, separately order the common connector assemblies listed on the previous page.

# F10, F15 Series Split Manifold Plug-in Type Order Codes

## Manifold outlet specification

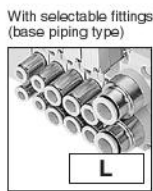
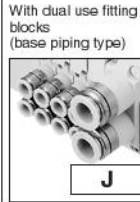

Outlet port fitting  
F10: φ4, φ6  
F15: φ6, φ8

Outlet port should be selected in accordance with the manifold fitting specification.

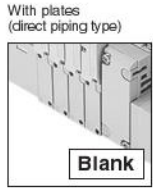
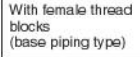

Outlet port female thread  
F10: M5 × 0.8  
F15: Rc1/8

## Valve size

- F10M** 10 mm [0.394 in.] width
- F15M** 15 mm [0.591 in.] width

## Pilot specification

**Blank**

Internal pilot manifold

**G**

External pilot manifold

## Piping block specification (air supply and exhaust)

### Fitting block

- JR : Dual use fitting, right-side mounting<sup>Note14</sup>
  - JL : Dual use fitting, left-side mounting<sup>Note14</sup>
  - JD : Dual use fitting, both-side mounting<sup>Note14</sup>
- Fitting size (1(P), 3, 5(R) ports), φ8, φ10

### Female thread block

- MR : Female thread, right-side mounting<sup>Note14</sup>
  - ML : Female thread, left-side mounting<sup>Note14</sup>
  - MD : Female thread, both-side mounting<sup>Note14</sup>
- Female thread size (1(P), 3, 5(R) ports), Rc1/4

### Female thread block

- MRH : Female thread, right-side mounting<sup>Note15</sup>
  - MLH : Female thread, left-side mounting<sup>Note15</sup>
  - MDH : Female thread, both-side mounting<sup>Note15</sup>
- Female thread size (1(P), 3, 5(R) ports), NPT1/4

### Single size fitting block

- JR5R : Single use fitting, right-side mounting<sup>Note14</sup>
  - JL5L : Single use fitting, left-side mounting<sup>Note14</sup>
  - JD5D : Single use fitting, both-side mounting<sup>Note14</sup>
- Fitting size (1(P), 3, 5(R) ports), φ8
- JR6R : Single use fitting, right-side mounting<sup>Note14</sup>
  - JL6L : Single use fitting, left-side mounting<sup>Note14</sup>
  - JD6D : Single use fitting, both-side mounting<sup>Note14</sup>
- Fitting size (1(P), 3, 5(R) ports), φ10

## Wiring specification (wiring block)

Flat cable connector (with socket and strain relief)

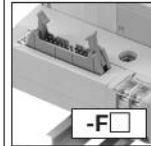

- <Connector top surface wiring>
- F100 : 10-pin
  - F100N : 10-pin without power terminal
  - F101 : 10-pin
  - F101N : 10-pin without power terminal
  - F200 : 20-pin
  - F200N : 20-pin without power terminal
  - F201 : 20-pin
  - F201N : 20-pin without power terminal
  - F260 : 26-pin
  - F260N : 26-pin without power terminal
- For details, see p. 92.



- <Connector side surface wiring>
- F100E : 10-pin
  - F100EN : 10-pin without power terminal
  - F101E : 10-pin
  - F101EN : 10-pin without power terminal
  - F200E : 20-pin
  - F200EN : 20-pin without power terminal
  - F201E : 20-pin
  - F201EN : 20-pin without power terminal
  - F260E : 26-pin
  - F260EN : 26-pin without power terminal

D-sub connector

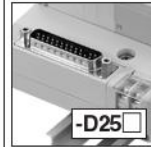

- <Connector top surface wiring>
- (M2.6 mounting screws)
- D250 : 25-pin<sup>Note14</sup>
  - D250N : 25-pin without power terminal<sup>Note14</sup>
  - D251 : 25-pin<sup>Note14</sup>
  - D251N : 25-pin without power terminal<sup>Note14</sup>
- (4-40 UNC mounting screws)
- D250U : 25-pin<sup>Note15</sup>
  - D251U : 25-pin<sup>Note15</sup>
  - D370NU : 37-pin without power terminal<sup>Note15</sup>
- For details, see p. 92-96.



- <Connector side surface wiring>
- (M2.6 mounting screws)
- D250E : 25-pin<sup>Note14</sup>
  - D250EN : 25-pin without power terminal<sup>Note14</sup>
  - D251E : 25-pin<sup>Note14</sup>
  - D251EN : 25-pin without power terminal<sup>Note14</sup>
- (4-40 UNC mounting screws)
- D250EU : 25-pin<sup>Note15</sup>
  - D251EU : 25-pin<sup>Note15</sup>

Terminal block (19 terminals, M3 screws)

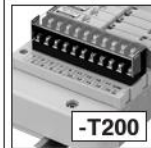

Also can provide the terminal block with cover.<sup>Note14</sup>

For details, see p. 92-96.

## Wiring connection specification

**Blank**

**Packed wiring:**  
Wiring is made in accordance with the mounted valve specifications.

**-W**

**Double wiring:**  
Wiring is always for the double solenoid, regardless of the specifications of the mounted valve.

## Wiring position (wiring block)

- Blank** : Left-side mounting
- R** : Right-side mounting

## Valve size

- F10** Standard type
- F10L** Low-current type
- F15** Standard type
- F15L** Low-current type

Note: Valves of **F10** and **F15** cannot be mounted together.

Valve size	Valve units	Manifold type	Manifold outlet specification	Pilot specification	Piping block specification	Wiring specification	Wiring connection specification	Wiring position	Voltage
Manifold model									

Base piping type	Base piping type selectable fitting	Manifold type	Manifold outlet specification	Pilot specification	Piping block specification					Wiring connection specification	Wiring position	Voltage		
					-JR	-JR5R	-F100	-F201	-D251				-F200E	-D250E
Base piping type	F10M	P	J	Blank	-JR	-JR5R	-F100	-F201	-D251	-F200E	-D250E	Blank	Blank	DC24V
					-JL	-JL5L	-F100N	-F201N	-D251N	-F200EN	-D250EN			
Base piping type selectable fitting	F15M	P	L	Blank	-JR	-JR5R	-F100	-F201	-D250U <sup>Note15</sup>	-F200E	-D250EN <sup>Note14</sup>	Blank	Blank	DC24V
					-JL	-JL5L	-F100N	-F260	-D251U <sup>Note15</sup>	-F200EN	-D251EN <sup>Note14</sup>			
Direct piping type	Blank	PH	Blank	Blank	-JR	-JR5R	-F100	-F201	-D370NU <sup>Note15</sup>	-F201E	-D251EN <sup>Note14</sup>	Blank	Blank	DC24V
					-JL	-JL5L	-F101	-F260N	-F101E	-F201EN	-D251EU <sup>Note15</sup>			

Notes: 1. For the maximum number of units, see the table for maximum number of valve units by wiring specification, on p. 66.  
 2. Not available in low-current type.  
 3. AC100V is available only for the -D250□, -D251□, -D370NU (D-sub connector) and -T200 (terminal block) wiring specifications. In addition, not available in low-current type and tandem 3-port valves.  
 4. The terminal block with cover is also available as a made to order product (add -139W to the end of the manifold model order code). For details, consult us.

Remark: Negative common specifications are also available as made to order products (add -129W to the ends of the valve and manifold model order codes). For details, consult us.

Valve specification

- T0 : 2-position, for single solenoid only
- T1 : 2-position, single solenoid specification
- T2 : 2-position, double solenoid specification
- T3 : 3-position, closed center
- T4 : 3-position, exhaust center
- T5 : 3-position, pressure center
- TA : Tandem 3-port (NC and NC)<sup>Note12</sup>
- TB : Tandem 3-port (NO and NO)<sup>Note12</sup>
- TC : Tandem 3-port (NC and NO)<sup>Note12</sup>

Operation type

Blank

Internal pilot type<sup>Note10</sup>

G

External pilot type<sup>Note11</sup>  
(for positive pressure)

※ No vacuum valve can be mounted.

Manual override

Manual override button



Blank

Manual override lever<sup>Note8</sup>

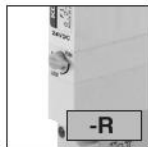

-R

Valve outlet type

-A1 With plate<sup>Note6</sup>  
(base piping type)

5-port specification

- FJ With dual use fitting block<sup>Note14</sup>  
(direct piping type) F10: φ 4, φ 6  
F15: φ 6, φ 8
- FJ5 With single use fitting block<sup>Note14</sup>  
(direct piping type) F10: φ 4  
F15: φ 6
- FJ6 With single use fitting block<sup>Note14</sup>  
(direct piping type) F10: φ 6  
F15: φ 8
- FM With female thread block<sup>Note14</sup>  
(direct piping type) F10: M5 × 0.8  
F15: Rc1/8
- FMH With female thread block<sup>Note15</sup>  
(direct piping type) F10: 10-32UNF  
F15: NPT1/8

3-port specification

- FJ5A With single use fitting block, normally closed (NC)<sup>Note14</sup>  
(direct piping type) F10: φ 4  
F15: φ 6
- FJ5B With single use fitting block, normally open (NO)<sup>Note14</sup>  
(direct piping type) F10: φ 4  
F15: φ 6
- FJ6A With single use fitting block, normally closed (NC)<sup>Note14</sup>  
(direct piping type) F10: φ 6  
F15: φ 8
- FJ6B With single use fitting block, normally open (NO)<sup>Note14</sup>  
(direct piping type) F10: φ 6  
F15: φ 8
- FMA With female thread block, normally closed (NC)<sup>Note14</sup>  
(direct piping type) F10: M5 × 0.8  
F15: Rc1/8
- FMAH With female thread block, normally closed (NC)<sup>Note15</sup>  
(direct piping type) F10: 10-32UNF  
F15: NPT1/8
- FMB With female thread block, normally open (NO)<sup>Note14</sup>  
(direct piping type) F10: M5 × 0.8  
F15: Rc1/8
- FMBH With female thread block, normally open (NO)<sup>Note15</sup>  
(direct piping type) F10: 10-32UNF  
F15: NPT1/8

Caution: The 3-port specifications are only available in the valve specification T0, T1, and T2.

Manifold fitting specification

5-port specification

- J5 With single use fitting block<sup>Note14</sup>  
(base piping type) F10: φ 4  
F15: φ 6
- J6 With single use fitting block<sup>Note14</sup>  
(base piping type) F10: φ 6  
F15: φ 8
- M With female thread block<sup>Note14</sup>  
(base piping type) F10: M5 × 0.8  
F15: Rc1/8
- MH With female thread block<sup>Note15</sup>  
(base piping type) F10: 10-32UNF  
F15: NPT1/8

3-port specification

- J5A With single use fitting block, normally closed (NC)<sup>Note14</sup>  
(base piping type) F10: φ 4  
F15: φ 6
- J5B With single use fitting block, normally open (NO)<sup>Note14</sup>  
(base piping type) F10: φ 4  
F15: φ 6
- J6A With single use fitting block, normally closed (NC)<sup>Note14</sup>  
(base piping type) F10: φ 6  
F15: φ 8
- J6B With single use fitting block, normally open (NO)<sup>Note14</sup>  
(base piping type) F10: φ 6  
F15: φ 8
- MA With female thread block, normally closed (NC)<sup>Note14</sup>  
(base piping type) F10: M5 × 0.8  
F15: Rc1/8
- MAH With female thread block, normally closed (NC)<sup>Note15</sup>  
(base piping type) F10: 10-32UNF  
F15: NPT1/8
- MB With female thread block, normally open (NO)<sup>Note14</sup>  
(base piping type) F10: M5 × 0.8  
F15: Rc1/8
- MBH With female thread block, normally open (NO)<sup>Note15</sup>  
(base piping type) F10: 10-32UNF  
F15: NPT1/8

Caution: The 3-port specifications are only available in the valve specification T0, T1, and T2.

Back pressure prevention valve

Blank

No back pressure prevention valve

-E2

With back pressure prevention valve<sup>Note13</sup>

Individual air supply and exhaust spacer

- Blank : No spacer
  - PPM : Individual air supply spacer (with M5 female thread for F10)
  - PP6 : Individual air supply spacer (with φ 6 fitting for F15)
  - PP8 : Individual air supply spacer (with φ 8 fitting for F15)
  - PRM : Individual exhaust spacer (with M5 female thread for F10)
  - PR6 : Individual exhaust spacer (with φ 6 fitting for F15)
  - PR8 : Individual exhaust spacer (with φ 8 fitting for F15)
- For details, see p. 25.

Port isolator

- Blank : No port isolator
- SP : For 1(P) port<sup>Note9</sup>
- SR : For 3(R2), 5(R1) ports<sup>Note9</sup>
- SA : For 1(P), 3(R2), and 5(R1) ports<sup>Note9</sup>

Station	Valve size	Valve specification	Operation type	Manual override	Valve outlet type	Manifold fitting specification	Back pressure prevention valve	Individual air supply and exhaust spacer	Port Isolator	Voltage
Mounting valve model										
str. 1 . . . str. □ Note5	F10 F10L F15 F15L	T0 T3 TA <sup>Note12</sup> T1 T4 TB <sup>Note12</sup> T2 T5 TC <sup>Note12</sup>	Blank <sup>Note10</sup> G <sup>Note11</sup>	Blank -R <sup>Note8</sup>	-A1 <sup>Note6</sup>		Blank -E2 <sup>Note13</sup>	Blank -PPM -PRM -PP6 -PR6 -PP8 -PR8	Blank -SP <sup>Note9</sup> -SR <sup>Note9</sup> -SA <sup>Note9</sup>	DC24V DC12V <sup>Note2</sup> AC100V <sup>Note3</sup> AC120V <sup>Note3</sup>
	F10 F15	BPP (for block-off plate) <sup>Note7</sup>								
str. 1 . . . str. □ Note5	F10 F10L F15 F15L	T0 T3 TA <sup>Note12</sup> T1 T4 TB <sup>Note12</sup> T2 T5 TC <sup>Note12</sup>	Blank <sup>Note10</sup> G <sup>Note11</sup>	Blank -R <sup>Note8</sup>	-A1 <sup>Note6</sup>	-J5 <sup>Note14</sup> -J6 <sup>Note14</sup> -J6 <sup>Note14</sup> -J6B <sup>Note14</sup> -M <sup>Note14</sup> -MA <sup>Note14</sup> -MH <sup>Note15</sup> -MAH <sup>Note15</sup> -J5A <sup>Note14</sup> -MB <sup>Note14</sup> -J5B <sup>Note14</sup> -MBH <sup>Note15</sup>	Blank -E2 <sup>Note13</sup>	Blank -PPM -PRM -PP6 -PR6 -PP8 -PR8	Blank -SP <sup>Note9</sup> -SR <sup>Note9</sup> -SA <sup>Note9</sup>	DC24V DC12V <sup>Note2</sup> AC100V <sup>Note3</sup> AC120V <sup>Note3</sup>
	F10 F15	BPP (for block-off plate) <sup>Note7</sup>								
str. 1 . . . str. □ Note5	F10 F10L F15 F15L	T0 T3 TA <sup>Note12</sup> T1 T4 TB <sup>Note12</sup> T2 T5 TC <sup>Note12</sup>	Blank <sup>Note10</sup> G <sup>Note11</sup>	Blank -R <sup>Note8</sup>	-A1 <sup>Note6</sup>	-FJ <sup>Note14</sup> -FJA <sup>Note14</sup> -FJ5 <sup>Note14</sup> -FJ5A <sup>Note14</sup> -FJ6 <sup>Note14</sup> -FJ6A <sup>Note14</sup> -FM <sup>Note14</sup> -FMA <sup>Note14</sup> -FMH <sup>Note15</sup> -FMAH <sup>Note15</sup> -FMAH <sup>Note15</sup> -FMAH <sup>Note15</sup> -FMB <sup>Note14</sup> -FMBH <sup>Note15</sup> -FJ5A <sup>Note14</sup> -FMBH <sup>Note15</sup> -FJ5B <sup>Note14</sup>	Blank -E2 <sup>Note13</sup>	Blank -PPM -PRM -PP6 -PR6 -PP8 -PR8	Blank -SP <sup>Note9</sup> -SR <sup>Note9</sup> -SA <sup>Note9</sup>	DC24V DC12V <sup>Note2</sup> AC100V <sup>Note3</sup> AC120V <sup>Note3</sup>
	F10 F15	BPP (for block-off plate) <sup>Note7</sup>								

Notes: 5. Valve mounting location is from the left, with the solenoid on top, and the 4(A), 2(B) ports side in front.  
6. When selecting J, M, or L (base piping type) for the manifold outlet specification, always enter -A1 (with plate) for the valve outlet type.  
7. Caution should be exercised that the block-off plate wiring is always double wiring (allocated 2 control pins at 1 str.), regardless of the wiring connection specification. For wiring for a single solenoid, see p. 67.  
8. When the valve specification is T1 or T2, the manual override lever is placed only on the A side.  
9. Port isolators can be installed only when piping blocks are mounted on both sides. In addition, only 1 port isolator can be mounted in 1 manifold for -SA, or 1 each port isolator for -SP and -SR for a total of 2 locations. When shipping, the designated port isolators are mounted between the designated station and the station to its immediate left (the next smaller str. No.).  
10. Cannot be mounted on the external pilot manifold.  
11. Cannot be mounted on the internal pilot manifold.  
12. Not available in external pilot type.  
13. Not available with the individual exhaust spacer.  
14. Can be selected only when the manifold type is P.  
15. Can be selected only when the manifold type is PH.

## Parts for manifold

F  Z -

- Valve size**  
 10: 10 mm [0.394 in.] width  
 15: 15 mm [0.591 in.] width
- Parts content**  
**GS2** : Gasket (gasket and exhaust valve)  
**SP** : Port isolator (for 1(P) port)  
**SR** : Port isolator (for 3(R2), 5(R1) ports)  
**SA** : Port isolator (for 1(P), 3(R2), 5(R1) ports)

## Block-off plate (block-off plate, 2 mounting screws, and plug)

F  BP P

- Valve size**  
 10: 10 mm [0.394 in.] width  
 15: 15 mm [0.591 in.] width
- For plug-in type

## Valve base assembly (valve base, gasket, lead wire, and plug-in connector)

F  Z  -  -

- Valve size**  
 10: 10 mm [0.394 in.] width  
 15: 15 mm [0.591 in.] width
- Piping specification**  
**VJ** : Dual use fitting valve base  
**VJ5** : Single use fitting valve base F10: φ 4, F15: φ 6  
**VJ6** : Single use fitting valve base F10: φ 6, F15: φ 8  
**VJ5A** : 3-port specification normally closed, single use fitting valve base F10: φ 4, F15: φ 6  
**VJ5B** : 3-port specification normally open, single use fitting valve base F10: φ 4, F15: φ 6  
**VJ6A** : 3-port specification normally closed, single use fitting valve base F10: φ 6, F15: φ 8  
**VJ6B** : 3-port specification normally open, single use fitting valve base F10: φ 6, F15: φ 8  
**VM** : Female thread valve base F10: M5 × 0.8, F15: Rc1/8  
**VMA** : 3-port specification normally closed, female thread valve base F10: M5 × 0.8, F15: Rc1/8  
**VMB** : 3-port specification normally open, female thread valve base F10: M5 × 0.8, F15: Rc1/8  
**VMH** : Female thread valve base F10: 10-32UNF, F15: NPT1/8  
**VMAH** : 3-port specification normally closed, female thread valve base F10: 10-32UNF, F15: NPT1/8  
**VMBH** : 3-port specification normally open, female thread valve base F10: 10-32UNF, F15: NPT1/8  
**VP** : Valve base plate
- Wiring specification**  
**D** : For D-sub connector  
**F** : For flat cable connector, terminal block
- Pilot specification**  
**Blank** : Internal pilot  
**G** : External pilot

## Wiring block assembly (one set)

F  Z -  -

- Valve size**  
 10: 10 mm [0.394 in.] width  
 15: 15 mm [0.591 in.] width
- Voltage (Not required for T200)**  
**DC24**  
**DC12**  
**AC100** (for D250, D251, D370NU only)
- Piping specification**  
**F100** : Flat cable connector (DC specification)  
**F101** : Flat cable connector (DC specification)  
**F200** : Flat cable connector (DC specification)  
**F201** : Flat cable connector (DC specification)  
**F260** : Flat cable connector (DC specification)  
**D250** : D-sub connector (M2.6 screws)  
**D251** : D-sub connector (M2.6 screws)  
**D250U** : D-sub connector (4-40UNC screws)  
**D251U** : D-sub connector (4-40UNC screws)  
**F100N** : Flat cable connector (DC specification), without power terminal  
**F101N** : Flat cable connector (DC specification), without power terminal  
**F200N** : Flat cable connector (DC specification), without power terminal  
**F201N** : Flat cable connector (DC specification), without power terminal  
**F260N** : Flat cable connector (DC specification), without power terminal  
**D250N** : D-sub connector, without power terminal  
**D251N** : D-sub connector, without power terminal  
**D370NU** : D-sub connector (4-40UNC screws), without power terminal  
**T200L** : Terminal block for left-side mounting  
**T200R** : Terminal block for right-side mounting

## Back pressure prevention valve (2 pieces for split type, with dedicated gasket)

F  Z - E2

- Valve size**  
 10: 10 mm [0.394 in.] width  
 15: 15 mm [0.591 in.] width

## Individual air supply and exhaust spacer (Spacer for plug-in type, gasket, exhaust valve, and 2 mounting screws)

F  Z -

- Valve size**  
 10: 10 mm [0.394 in.] width  
 15: 15 mm [0.591 in.] width
- Specification**  
**PPM** : Individual air supply spacer (with M5 female thread for F10)  
**PP6** : Individual air supply spacer (with φ 6 fitting for F15)  
**PP8** : Individual air supply spacer (with φ 8 fitting for F15)  
**PRM** : Individual exhaust spacer (with M5 female thread for F10)  
**PR6** : Individual exhaust spacer (with φ 6 fitting for F15)  
**PR8** : Individual exhaust spacer (with φ 8 fitting for F15)

※For details, see p.25.

## Piping block assembly

F  Z  -

- Valve size**  
 10: 10 mm [0.394 in.] width  
 15: 15 mm [0.591 in.] width
- Piping specification**  
**PJ** : Dual use fitting piping block  
**PJ5** : Single use fitting piping block φ 8  
**PJ6** : Single use fitting piping block φ 10  
**PM** : Female thread piping block Rc1/4  
**PMH** : Female thread piping block NPT1/4
- Pilot specification**  
**Blank** : Internal pilot  
**G** : External pilot

## Muffler

KM - J

- Fitting size**  
**6** : Outer diameter φ 6 (for individual exhaust spacer)  
**8** : Outer diameter φ 8 (for individual exhaust spacer)  
**10** : Outer diameter φ 10  
 (Sales unit: Set of 10 mufflers)

## End blocks (one set of left and right)

F  Z  -

- Valve size**  
 10: 10 mm [0.394 in.] width  
 15: 15 mm [0.591 in.] width
- End block specification**  
**E** : For wiring specification T200  
**EL** : For wiring block left side  
**ER** : For wiring block right side
- Pilot specification**  
**Blank** : Internal pilot  
**G** : External pilot

## Table for maximum number of valve units by wiring specification

Wiring specification	Max. outputs	Maximum number of units		
		Wiring connection specification		
		Packed wiring (Blank)	Double wiring (-W)	
F100 <input type="checkbox"/> Flat cable (10P)	8	Varies depending on the number of mounted single solenoids, double solenoids, and block-off plates. The number of controlled solenoids should be designated as the maximum number of outputs or less.	4 units	
F101 <input type="checkbox"/> Flat cable (10P)	8		4 units	
F200 <input type="checkbox"/> Flat cable (20P)	16		8 units	
F201 <input type="checkbox"/> Flat cable (20P)	16		8 units	
F260 <input type="checkbox"/> Flat cable (26P)	20		10 units	
D250 <input type="checkbox"/> D-sub connector (25P)	16		8 units	
D251 <input type="checkbox"/> D-sub connector (25P)	20		10 units	
D370NU D-sub connector (37P)	32		D370NU is a maximum of 20 units.	16 units
T200 Terminal block (19 terminals)	18			9 units

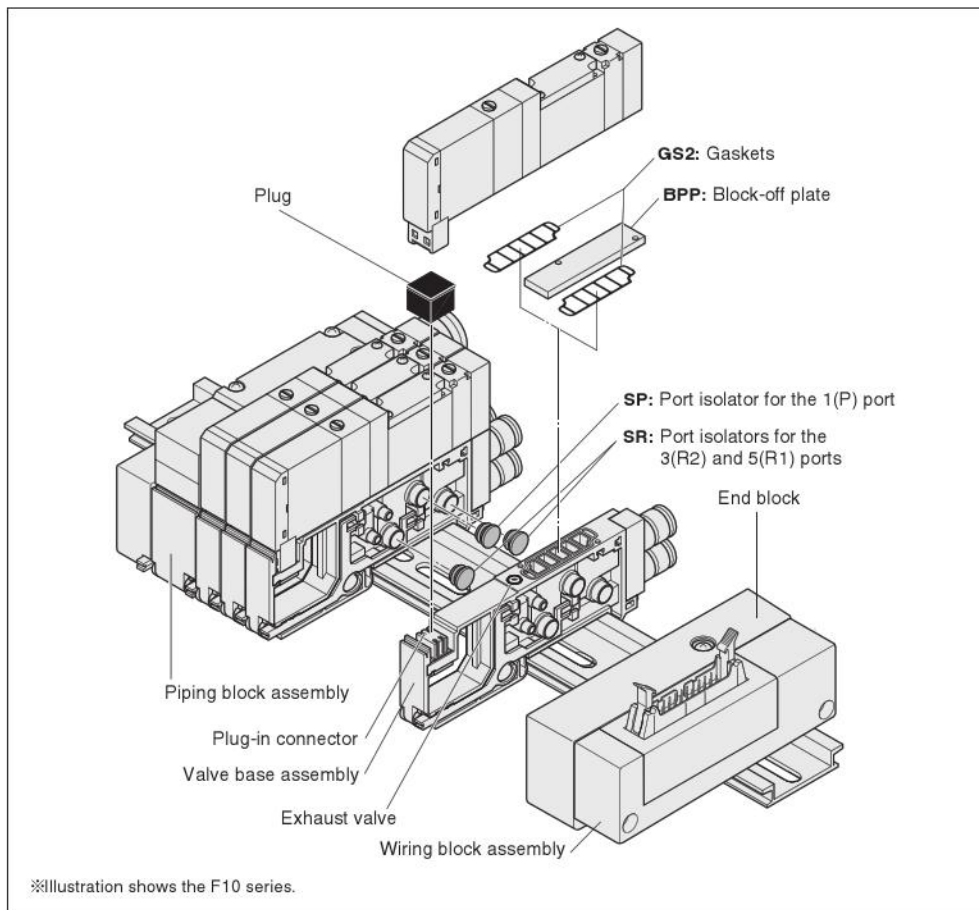

### Manifold Order Code Example

(12 units of F10 Series)

**F10M12PL-J5R-F201 DC24V**

stn.1~8 F10T0-A1-J5 DC24V

stn.9~11 F10T2-A1-J6 DC24V

stn.12 F10BPP-J6

Note: This order code example has no relationship to the illustration above.

### Precautions for Order Codes

#### ● Orders for valves only

Place orders from "Single Valve Unit Order Codes" on p. 44.

However, **Blank**, **A2**, **F3**, **F4**, **F5**, **F6**, **F4A**, **F4B**, **F5A**, **F5B**, **F6A**, and **F6B** cannot be selected for the valve outlet type. For the wiring specification, **Blank** is the only selection.

#### ● Wiring connection specification

**Blank** (packed wiring): Wiring is made in accordance with the mounted valve specifications.

**-W** (double wiring): Wiring is always for the double solenoid, regardless of the specifications of the mounted valve.

#### Caution

Caution should be exercised that the block-off plate wiring is always double wiring (allocated 2 control pins at 1 stn.), regardless of the wiring connection specification.

The block-off plate wiring can be made as wiring for a single solenoid. Add **-1W** to the end of the block-off plate order code in the case.

For details, consult us.

# F10, F15 Series Serial Transmission Compatible Manifold Order Codes

## Manifold outlet specification

With dual use fitting blocks (base piping type)



J

Outlet port fitting  
F10: φ4, φ6  
F15: φ6, φ8

With selectable fittings (base piping type)



L

Outlet port should be selected in accordance with the manifold fitting specification.

With female thread blocks (base piping type)

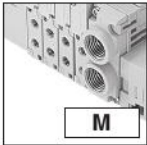

M

Outlet port female thread  
F10: M5 × 0.8  
F15: Rc1/8

With plates (direct piping type)

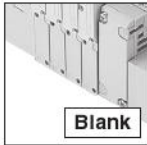

Blank

## Valve size

**F10M** 10 mm [0.394 in.] width

**F15M** 15 mm [0.591 in.] width

## Pilot specification

**Blank**

Internal pilot manifold

**G**

External pilot manifold

## Piping block specification (air supply and exhaust)

### Fitting block

- JR : Dual use fitting, right-side mounting<sup>Note 13</sup>
  - JL : Dual use fitting, left-side mounting<sup>Note 13</sup>
  - JD : Dual use fitting, both-side mounting<sup>Note 13</sup>
- Fitting size (1(P), 3, 5(R) ports), φ8, φ10

### Female thread block

- MR : Female thread, right-side mounting<sup>Note 13</sup>
  - ML : Female thread, left-side mounting<sup>Note 13</sup>
  - MD : Female thread, both-side mounting<sup>Note 13</sup>
- Female thread size (1(P), 3, 5(R) ports), Rc1/4

### Female thread block

- MRH : Female thread, right-side mounting<sup>Note 14</sup>
  - MLH : Female thread, left-side mounting<sup>Note 14</sup>
  - MDH : Female thread, both-side mounting<sup>Note 14</sup>
- Female thread size (1(P), 3, 5(R) ports), NPT1/4

### Single use fitting block

- J5R : Single use fitting, right-side mounting<sup>Note 13</sup>
  - J5L : Single use fitting, left-side mounting<sup>Note 13</sup>
  - J5D : Single use fitting, both-side mounting<sup>Note 13</sup>
- Fitting size (1(P), 3, 5(R) ports), φ8
- J6R : Single use fitting, right-side mounting<sup>Note 13</sup>
  - J6L : Single use fitting, left-side mounting<sup>Note 13</sup>
  - J6D : Single use fitting, both-side mounting<sup>Note 13</sup>
- Fitting size (1(P), 3, 5(R) ports), φ10

## Transmission block specification

※ These are the serial transmission block specifications compatible with each system.



● Block on the right photo is the case of B7A Link Terminal. For details, see p.37-39.

### Integrated type

- A1 : For OMRON CompoBus/S (16 outputs)
- B1 : For CC-Link (16 outputs)<sup>Note 2</sup>
- B3 : For CC-Link (32 outputs)<sup>Note 2</sup>
- D1 : For DeviceNet (16 outputs)
- D3 : For DeviceNet (32 outputs)
- H1 : For CompoNet (16 outputs)
- K1 : For EtherCAT (16 outputs)
- K3 : For EtherCAT (32 outputs)<sup>Note 2</sup>
- M1 : For EtherNet/IP (16 outputs)<sup>Note 2</sup>
- M3 : For EtherNet/IP (32 outputs)<sup>Note 2</sup>

### Stand-alone type

- 31 : For OMRON B7A Link Terminal (standard)
- 32 : For OMRON B7A Link Terminal (high speed)

## Wiring connection specification

**Blank**

**Packed wiring:** Wiring is made in accordance with the mounted valve specifications.

**-W**

**Double wiring:** Wiring is always for the double solenoid, regardless of the specifications of the mounted valve.

## Wiring position (transmission block)

**Blank** : Left-side mounting  
**-R** : Right-side mounting

## Valve size

**F10** Standard type

**F10L** Low-current type

**F15** Standard type

**F15L** Low-current type

Note: Valves of F10□ and F15□ cannot be mounted together.

Valve size	Valve units	Manifold type	Manifold outlet specification	Pilot specification	Piping block specification	Transmission block specification	Wiring connection specification	Wiring position
------------	-------------	---------------	-------------------------------	---------------------	----------------------------	----------------------------------	---------------------------------	-----------------

		Manifold model										
Base piping type	F10M F15M Note 3	2 : : : □ Note 1	S	J M	Blank G	-JR -JL -JD -MR -ML -MD	-J5R -J6R -J5L -J6L -J5D -J6D	-31 -32 -A1 -B1 -B3	-D1 -D3 -H1 -K1 -K3	-M1 <sup>Note 2</sup> -M3 <sup>Note 2</sup>	Blank -W	Blank -R
			S	L	Blank G	-JR <sup>Note 13</sup> -JL <sup>Note 13</sup> -JD <sup>Note 13</sup> -MR <sup>Note 13</sup> -ML <sup>Note 13</sup> -MD <sup>Note 13</sup> -MRH <sup>Note 14</sup> -MLH <sup>Note 14</sup>	-MDH <sup>Note 14</sup> -J5R <sup>Note 13</sup> -J6R <sup>Note 13</sup> -J5L <sup>Note 13</sup> -J6L <sup>Note 13</sup> -J5D <sup>Note 13</sup> -J6D <sup>Note 13</sup>	-31 -32 -A1 -B1 -B3	-D1 -D3 -H1 -K1 -K3	-M1 <sup>Note 2</sup> -M3 <sup>Note 2</sup>	Blank -W	Blank -R
			SH	Blank	Blank G	-JR <sup>Note 13</sup> -JL <sup>Note 13</sup> -JD <sup>Note 13</sup> -MR <sup>Note 13</sup> -ML <sup>Note 13</sup> -MD <sup>Note 13</sup> -MRH <sup>Note 14</sup> -MLH <sup>Note 14</sup>	-MDH <sup>Note 14</sup> -J5R <sup>Note 13</sup> -J6R <sup>Note 13</sup> -J5L <sup>Note 13</sup> -J6L <sup>Note 13</sup> -J5D <sup>Note 13</sup> -J6D <sup>Note 13</sup>	-31 -32 -A1 -B1 -B3	-D1 -D3 -H1 -K1 -K3	-M1 <sup>Note 2</sup> -M3 <sup>Note 2</sup>	Blank -W	Blank -R

Notes: 1. To determine the maximum number of units, see the table for maximum number of valve units by transmission block specification, on p. 70.  
Notes: 2. CE marking compliant.  
Notes: 3. Contact our nearest sales office for information about the F18 series.

- Valve specification**
- T0 : 2-position, for single solenoid only
  - T1 : 2-position, single solenoid specification
  - T2 : 2-position, double solenoid specification
  - T3 : 3-position, closed center
  - T4 : 3-position, exhaust center
  - T5 : 3-position, pressure center
  - TA : Tandem 3-port (NC and NC)<sup>Note11</sup>
  - TB : Tandem 3-port (NO and NO)<sup>Note11</sup>
  - TC : Tandem 3-port (NC and NO)<sup>Note11</sup>

**Operation type**

Blank

Internal pilot type<sup>Note9</sup>

G

External pilot type<sup>Note10</sup>  
(for positive pressure)  
※ No vacuum valve can be mounted.

**Manual override**

Manual override button



Blank

Manual override lever<sup>Note7</sup>

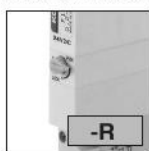

-R

**Valve outlet type**

**-A1** With plate<sup>Note5</sup>  
(base piping type)

**5-port specification**

**-FJ** With dual use fitting block<sup>Note13</sup>  
(direct piping type) F10: φ 4, φ 6  
F15: φ 6, φ 8

**-FJ5** With single use fitting block<sup>Note13</sup>  
(direct piping type) F10: φ 4  
F15: φ 6

**-FJ6** With single use fitting block<sup>Note13</sup>  
(direct piping type) F10: φ 6  
F15: φ 8

**-FM** With female thread block<sup>Note13</sup>  
(direct piping type) F10: M5 × 0.8  
F15: Rc 1/8

**-FMH** With female thread block<sup>Note14</sup>  
(direct piping type) F10: 10-32UNF  
F15: NPT 1/8

**3-port specification**

**-FJ5A** With single use fitting block, normally closed (NC)<sup>Note13</sup>  
(direct piping type) F10: φ 4  
F15: φ 6

**-FJ5B** With single use fitting block, normally open (NO)<sup>Note13</sup>  
(direct piping type) F10: φ 4  
F15: φ 6

**-FJ6A** With single use fitting block, normally closed (NC)<sup>Note13</sup>  
(direct piping type) F10: φ 6  
F15: φ 8

**-FJ6B** With single use fitting block, normally open (NO)<sup>Note12</sup>  
(direct piping type) F10: φ 6  
F15: φ 8

**-FMA** With female thread block, normally closed (NC)<sup>Note13</sup>  
(direct piping type) F10: M5 × 0.8  
F15: Rc 1/8

**-FMAH** With female thread block, normally closed (NC)<sup>Note14</sup>  
(direct piping type) F10: 10-32UNF  
F15: NPT 1/8

**-FMB** With female thread block, normally open (NO)<sup>Note13</sup>  
(direct piping type) F10: M5 × 0.8  
F15: Rc 1/8

**-FMBH** With female thread block, normally open (NO)<sup>Note14</sup>  
(direct piping type) F10: 10-32UNF  
F15: NPT 1/8

**Caution:** The 3-port specifications are only available in the valve specification T0, T1, and T2.

**Manifold fitting specification**

**5-port specification**

**-J5** With single use fitting block<sup>Note13</sup>  
(base piping type) F10: φ 4  
F15: φ 6

**-J6** With single use fitting block<sup>Note13</sup>  
(base piping type) F10: φ 6  
F15: φ 8

**-M** With female thread block<sup>Note13</sup>  
(base piping type) F10: M5 × 0.8  
F15: Rc 1/8

**-MH** With female thread block<sup>Note14</sup>  
(base piping type) F10: 10-32UNF  
F15: NPT 1/8

**3-port specification**

**-J5A** With single use fitting block, normally closed (NC)<sup>Note13</sup>  
(base piping type) F10: φ 4  
F15: φ 6

**-J5B** With single use fitting block, normally open (NO)<sup>Note13</sup>  
(base piping type) F10: φ 4  
F15: φ 6

**-J6A** With single use fitting block, normally closed (NC)<sup>Note13</sup>  
(base piping type) F10: φ 6  
F15: φ 8

**-J6B** With single use fitting block, normally open (NO)<sup>Note13</sup>  
(base piping type) F10: φ 6  
F15: φ 8

**-MA** With female thread block, normally closed (NC)<sup>Note13</sup>  
(base piping type) F10: M5 × 0.8  
F15: Rc 1/8

**-MAH** With female thread block, normally closed (NC)<sup>Note14</sup>  
(base piping type) F10: 10-32UNF  
F15: NPT 1/8

**-MB** With female thread block, normally open (NO)<sup>Note13</sup>  
(base piping type) F10: M5 × 0.8  
F15: Rc 1/8

**-MBH** With female thread block, normally open (NO)<sup>Note14</sup>  
(base piping type) F10: 10-32UNF  
F15: NPT 1/8

**Caution:** The 3-port specifications are only available in the valve specification T0, T1, and T2.

**Back pressure prevention valve**

Blank

No back pressure prevention valve

-E2

With back pressure prevention valve<sup>Note12</sup>

**Individual air supply and exhaust spacer**

- Blank : No spacer
  - PPM : Individual air supply spacer (with M5 female thread for F10)
  - PP6 : Individual air supply spacer (with φ 6 fitting for F15)
  - PP8 : Individual air supply spacer (with φ 8 fitting for F15)
  - PRM : Individual exhaust spacer (with M5 female thread for F10)
  - PR6 : Individual exhaust spacer (with φ 6 fitting for F15)
  - PR8 : Individual exhaust spacer (with φ 8 fitting for F15)
- For details, see p. 25.

Station	Valve size	Valve specification	Operation type	Manual override	Valve outlet type	Manifold fitting specification	Back pressure prevention valve	Individual air supply and exhaust spacer	Port Isolator	Voltage
Mounting valve model										
stn. 1 ⋮ stn. □ Note4	F10 F10L F15 F15L	T0 T3 TA <sup>Note11</sup> T1 T4 TB <sup>Note11</sup> T2 T5 TC <sup>Note11</sup>	Blank <sup>Note9</sup> G <sup>Note10</sup>	Blank -R <sup>Note7</sup>	-A1 <sup>Note5</sup>		Blank -E2 <sup>Note12</sup>	Blank -PPM -PRM -PP6 -PR6 -PP8 -PR8	Blank -SP <sup>Note8</sup> -SR <sup>Note8</sup> -SA <sup>Note8</sup>	DC24V
		BPP (for block-off plate) <sup>Note6</sup>								
stn. 1 ⋮ stn. □ Note4	F10 F10L F15 F15L	T0 T3 TA <sup>Note11</sup> T1 T4 TB <sup>Note11</sup> T2 T5 TC <sup>Note11</sup>	Blank <sup>Note9</sup> G <sup>Note10</sup>	Blank -R <sup>Note7</sup>	-A1 <sup>Note5</sup>	-J5 <sup>Note13</sup> -J6A <sup>Note13</sup> -J6 <sup>Note13</sup> -J6B <sup>Note13</sup> -M <sup>Note13</sup> -MA <sup>Note13</sup> -MH <sup>Note14</sup> -MAH <sup>Note14</sup> -J5A <sup>Note13</sup> -MB <sup>Note13</sup> -J5B <sup>Note13</sup> -MBH <sup>Note14</sup>	Blank -E2 <sup>Note12</sup>	Blank -PPM -PRM -PP6 -PR6 -PP8 -PR8	Blank -SP <sup>Note8</sup> -SR <sup>Note8</sup> -SA <sup>Note8</sup>	DC24V
		BPP (for block-off plate) <sup>Note6</sup>								
stn. 1 ⋮ stn. □ Note4	F10 F10L F15 F15L	T0 T3 TA <sup>Note11</sup> T1 T4 TB <sup>Note11</sup> T2 T5 TC <sup>Note11</sup>	Blank <sup>Note9</sup> G <sup>Note10</sup>	Blank -R <sup>Note7</sup>	-FJ <sup>Note13</sup> -FJ6A <sup>Note13</sup> -FJ5 <sup>Note13</sup> -FJ6B <sup>Note13</sup> -FJ6 <sup>Note13</sup> -FMA <sup>Note13</sup> -FM <sup>Note13</sup> -FMAH <sup>Note14</sup> -FMH <sup>Note14</sup> -FMB <sup>Note13</sup> -FJ5A <sup>Note13</sup> -FMBH <sup>Note14</sup> -FJ5B <sup>Note13</sup>		Blank -E2 <sup>Note12</sup>	Blank -PPM -PRM -PP6 -PR6 -PP8 -PR8	Blank -SP <sup>Note8</sup> -SR <sup>Note8</sup> -SA <sup>Note</sup>	DC24V
		BPP (for block-off plate) <sup>Note6</sup>								

Notes: 4. Valve mounting location is from the left, with the solenoid on top, and the 4(A), 2(B) ports side in front.  
 5. When selecting J, M, or L (base piping type) for the manifold outlet specifications, always enter -A1 (with plate) for the valve outlet type.  
 6. The wiring on the block off plate uses double wiring (2 control points allocated) regardless of the wiring specifications. However, we can provide block off plates with a -1W suffix on the model number for the block off plate wired for connecting single solenoids.  
 7. When the valve specification is T1 or T2, the manual override lever is placed only on the A side.  
 8. Port isolators can be installed only when piping blocks are mounted on both sides. In addition, only 1 port isolator can be mounted in 1 manifold for -SA, or 1 each port isolator for -SP and -SR for a total of 2 locations. When shipping, the designated port isolators are mounted between the designated station and the station to its immediate left (the next smaller stn. No.).  
 9. Cannot be mounted on the external pilot manifold.  
 10. Cannot be mounted on the internal pilot manifold.  
 11. Not available in external pilot type.  
 12. Not available with the individual exhaust spacer.  
 13. Can be selected only when the manifold type is S.  
 14. Can be selected only when the manifold type is SH.

Parts for manifold



- Valve size**  
 10: 10 mm [0.394 in.] width  
 15: 15 mm [0.591 in.] width
- Parts content**  
**GS2** : Gasket (gasket and exhaust valve)  
**SP** : Port isolator (for 1(P) port)  
**SR** : Port isolator (for 3(R2), 5(R1) ports)  
**SA** : Port isolator (for 1(P), 3(R2), 5(R1) ports)

Block-off plate (block-off plate, 2 mounting screws, and plug)



- Valve size**  
 10: 10 mm [0.394 in.] width  
 15: 15 mm [0.591 in.] width

Valve base assembly (valve base, gasket, lead wire, and plug-in connector)



- Valve size**  
 10: 10 mm [0.394 in.] width  
 15: 15 mm [0.591 in.] width
- Piping specification**  
**VJ** : Dual use fitting valve base  
**VJ5** : Single use fitting valve base F10: φ 4, F15: φ 6  
**VJ6** : Single use fitting valve base F10: φ 6, F15: φ 8  
**VJ5A** : 3-port specification normally closed, single use fitting valve base F10: φ 4, F15: φ 6  
**VJ5B** : 3-port specification normally open, single use fitting valve base F10: φ 4, F15: φ 6  
**VJ6A** : 3-port specification normally closed, single use fitting valve base F10: φ 6, F15: φ 8  
**VJ6B** : 3-port specification normally open, single use fitting valve base F10: φ 6, F15: φ 8  
**VM** : Female thread valve base F10: M5 × 0.8, F15: Rc1/8  
**VMA** : 3-port specification normally closed, female thread valve base F10: M5 × 0.8, F15: Rc1/8  
**VMB** : 3-port specification normally open, female thread valve base F10: M5 × 0.8, F15: Rc1/8  
**VMH** : Female thread valve base F10: 10-32UNF, F15: NPT1/8  
**VMAH** : 3-port specification normally closed, female thread valve base F10: 10-32UNF, F15: NPT1/8  
**VMBH** : 3-port specification normally open, female thread valve base F10: 10-32UNF, F15: NPT1/8  
**VP** : Valve base plate
- Pilot specification**  
**Blank** : Internal pilot  
**G** : External pilot

Piping block assembly



- Valve size**  
 10: 10 mm [0.394 in.] width  
 15: 15 mm [0.591 in.] width
- Piping specification**  
**PJ** : Dual use fitting piping block  
**PJ5** : Single use fitting piping block φ 8  
**PJ6** : Single use fitting piping block φ 10  
**PM** : Female thread piping block Rc1/4  
**PMH** : Female thread piping block NPT1/4
- Pilot specification**  
**Blank** : Internal pilot  
**G** : External pilot

End blocks (one set of left and right)



- Valve size**  
 10: 10 mm [0.394 in.] width  
 15: 15 mm [0.591 in.] width
- End block specification**  
**EL** : For left side  
**ER** : For right side
- Pilot specification**  
**Blank** : Internal pilot  
**G** : External pilot

Wiring block assembly ※



- Valve size**  
 10: 10 mm [0.394 in.] width  
 15: 15 mm [0.591 in.] width

※ Use this when the transmission block specification is -31, or -32.

Back pressure prevention valve (2 units for split type, with dedicated gasket)



- Valve size**  
 10: 10 mm [0.394 in.] width  
 15: 15 mm [0.591 in.] width

Individual air supply and exhaust spacer (Spacer for plug-in type, gasket, exhaust valve, and 2 mounting screws)



- Valve size**  
 10: 10 mm [0.394 in.] width  
 15: 15 mm [0.591 in.] width
- Specification**  
**PPM** : Individual air supply spacer (with M5 female thread for F10)  
**PP6** : Individual air supply spacer (with φ 6 fitting for F15)  
**PP8** : Individual air supply spacer (with φ 8 fitting for F15)  
**PRM** : Individual exhaust spacer (with M5 female thread for F10)  
**PR6** : Individual exhaust spacer (with φ 6 fitting for F15)  
**PR8** : Individual exhaust spacer (with φ 8 fitting for F15)
- ※ For details, see p.25.

Serial transmission block (single unit)



- Transmission block specification**  
**31** : For OMRON B7A Link Terminal (standard)  
**32** : For OMRON B7A Link Terminal (high speed)
- Wiring position**  
**L** : For stand-alone type, left-side mounting ※  
**R** : For stand-alone type, right-side mounting ※  
 ※ DIN rail included (length 75 mm [2.95 in.] )

Dedicated for manifold mounting



- Transmission block specification**  
**A1** : For OMRON CompoBus/S (16 outputs)  
**B1** : For CC-Link (16 outputs)  
**B3** : For CC-Link (32 outputs)  
**D1** : For DeviceNet (16 outputs)  
**D3** : For DeviceNet (32 outputs)  
**H1** : For CompoNet (16 outputs)



- Transmission block specification**  
**K1** : For EtherCAT (16 outputs)  
**K3** : For EtherCAT (32 outputs)  
**M1** : For EtherNet/IP (16 outputs)  
**M3** : For EtherNet/IP (32 outputs)
- Wiring position**  
**L** : Left-side mounting  
**R** : Right-side mounting

Muffler



- Fitting size**  
**6** : Outer diameter φ 6 (for individual exhaust spacer)  
**8** : Outer diameter φ 8 (for individual exhaust spacer)  
**10** : Outer diameter φ 10  
 (Sales unit: Set of 10 mufflers)

Table for maximum number of valve units by transmission block specification

Transmission block specifications	Max. outputs	Maximum number of units	
		Wiring connection specification	
		Packed wiring (Blank)	Double wiring (-W)
-31 : For OMRON B7A Link Terminal (standard)	16	Varies depending on the number of mounted single solenoids, double solenoids, and block-off plates. The number of controlled solenoids should be designated as the maximum number of outputs or less. -B3, -D3, and -K3-M3 are a maximum of 20 units.	8 units
-32 : For OMRON B7A Link Terminal (high speed)	16		8 units
-A1 : For OMRON CompoBus/S (16 outputs)	16		8 units
-B1 : For CC-Link (16 outputs)	16		8 units
-B3 : For CC-Link (32 outputs)	32		16 units
-D1 : For DeviceNet (16 outputs)	16		8 units
-D3 : For DeviceNet (32 outputs)	32		16 units
-H1 : For CompoNet (16 outputs)	16		8 units
-K1 : For EtherCAT (16 outputs)	16		8 units
-K3 : For EtherCAT (32 outputs)	32		16 units
-M1 : For EtherNet/IP (16 outputs)	16	8 units	
-M3 : For EtherNet/IP (32 outputs)	32	16 units	

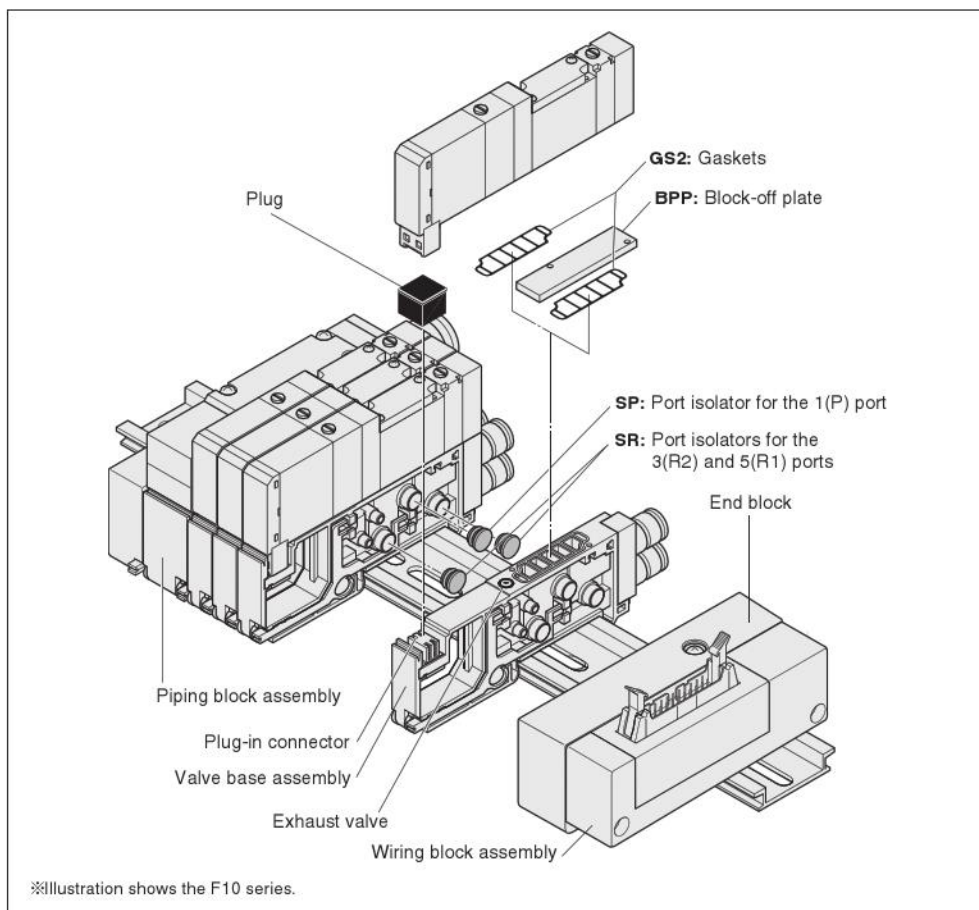

### Manifold Order Code Example

(8 units of F10 Series)

#### F10M8SL-J5R-B1-W

stn.1~5 F10T0-A1-J5 DC24V

stn.6~7 F10T2-A1-J6 DC24V

stn.8 F10BPP-J6

Note: This order code example has no relationship to the illustration above.

## Precautions for Order Codes

### ● Orders for valves only

Place orders from "Single Valve Unit Order Codes" on p. 44.

However, **Blank**, **A2**□, **F3**, **F4**□, **F5**, **F6**, **F4A**□, **F4B**□, **F5A**, **F5B**, **F6A**, and **F6B** cannot be selected for the valve outlet type. For the wiring specification, **Blank** is the only selection.

### ● Wiring connection specification













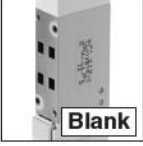

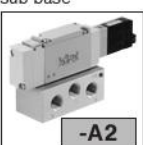





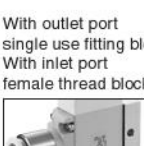

**Blank** (packed wiring): Wiring is made in accordance with the mounted valve specifications.

**-W** (double wiring): Wiring is always for the double solenoid, regardless of the specifications of the mounted valve.

#### Caution

Caution should be exercised that the block-off plate wiring is always double wiring (allocated 2 control pins at 1 stn.), regardless of the wiring connection specification. The block-off plate wiring can be made as wiring for a single solenoid. Add **-1W** to the end of the block-off plate order code in the case. For details, consult us.

# F18 Series Single Valve Unit Order Codes

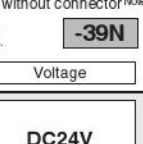
Valve size	Manual override	Valve outlet type	Wiring specification			
<b>F18</b> 18 mm [0.709 in.] width	Manual override button  No protrusion with DIN connector Manual override lever <sup>Note1</sup>  Protruding locking type <sup>Note5</sup> 	Without inlet/outlet block  With A type outlet plate  With A type sub-base  With A type sub-base 	With outlet port dual use fitting block  With outlet port single use fitting block  With outlet port single use fitting block  With outlet port female thread block  With outlet port female thread block 	With outlet port dual use fitting block With inlet port female thread block  Inlet port Rc1/4 Outlet port fitting $\phi 8, \phi 10$  Inlet port Rc1/4 Outlet port Rc1/4  Inlet port NPT1/4 Outlet port NPT1/4  Inlet port Rc1/4 Outlet port fitting $\phi 8$  Inlet port Rc1/4 Outlet port fitting $\phi 10$	L type plug connector Without connector  S type plug connector Without connector  S type plug connector Lead wire 300 mm <sup>*</sup>  L type plug connector Lead wire 300 mm <sup>*</sup>  S type plug connector Lead wire 3000 mm <sup>*</sup>  L type plug connector Lead wire 3000 mm <sup>*</sup>  DIN connector type with indicator <sup>Note6</sup>  DIN connector type without connector <sup>Note6</sup> 	
Valve size	Valve specification	Operation type	Manual override	Valve outlet type	Wiring specification	Voltage
F18	T0 T1 T2 T3 T4 <sup>Note4</sup> T5 <sup>Note4</sup>	Blank G V	Blank -R <sup>Note1</sup> -83 <sup>Note5</sup>	Blank <sup>Note2</sup> -A1 <sup>Note2</sup> -A2 -A2H -FJ <sup>Note2, 4</sup> -FJ5 <sup>Note2, 4</sup> -FJ6 <sup>Note2, 4</sup> -FM <sup>Note2, 4</sup> -FMH <sup>Note2, 4</sup> -F3 <sup>Note3</sup> -F4 <sup>Note3</sup> -F4H <sup>Note3</sup> -F5 <sup>Note3</sup> -F6 <sup>Note3</sup>	Blank -PN -PS -PL -PS3 -PL3 -39L <sup>Note6</sup> -39N <sup>Note6</sup>	DC24V DC12V AC100V <sup>Note7</sup> AC120V AC240V <sup>Note5</sup>

Notes: 1. When the valve specification is T1 or T2, the manual override lever is placed only on the A side. This is not available with -39□.  
 2. Two manifold mounting screws are included.  
 3. "With inlet port female thread block" is compatible with the internal pilot type valve only.  
 4. Not available in the vacuum valves.  
 5. Only for wiring specification -39□.

6. Not available for valve specification T1. In addition, the valve is used only as a double solenoid for T2.  
 7. Not available with DIN connectors.

Remark: Negative common specifications are also available as made to order products (add -129W to the end of order code). For details, consult us.

## F18 Series Single Valve Unit Additional Parts Order Codes

### ● For internal pilot

**F18 Z -**

**Parts content**

- 21** : Mounting bracket (mounting bracket, 2 mounting screws)
- 25** : Sub-base Rc1/4 (sub-base body, gasket, exhaust valve)<sup>Note1</sup>
- 25H** : Sub-base NPT1/4 (sub-base body, gasket, exhaust valve)<sup>Note1</sup>
- P** : Plate (plate, gasket, 2 mounting screws)
- J** : Dual use fitting block (fitting block, gasket, 2 mounting screws)
- J5** : Single use fitting block  $\phi$  8 (fitting block, gasket, 2 mounting screws)
- J6** : Single use fitting block  $\phi$  10 (fitting block, gasket, 2 mounting screws)
- M** : Female thread block Rc1/4 (female thread block, gasket, 2 mounting screws)
- MH** : Female thread block NPT1/4 (female thread block, gasket, 2 mounting screws)
- MP** : P port female thread block Rc1/4 (P port female thread block, gasket)<sup>Note1</sup>
- MPH** : P port female thread block NPT1/4 (P port female thread block, gasket)<sup>Note1</sup>
- GS1** : Gasket (gasket, exhaust valve)<sup>Note2</sup>

Notes: 1. Valve mounting screws are not included.  
 2. Caution should be exercised as this gasket is different from the **GS2** gasket for the split-type manifolds.

### ● For external pilot

**F18 Z -**

**Parts content**

- P** : Plate (plate, gasket, 2 mounting screws)
- J** : Dual use fitting block (fitting block, gasket, 2 mounting screws)
- J5** : Single use fitting block  $\phi$  8 (fitting block, gasket, 2 mounting screws)
- J6** : Single use fitting block  $\phi$  10 (fitting block, gasket, 2 mounting screws)
- M** : Female thread block Rc1/4 (female thread block, gasket, 2 mounting screws)
- MH** : Female thread block NPT1/4 (female thread block, gasket, 2 mounting screws)
- GS1** : Gasket (gasket, exhaust valve)<sup>Note</sup>

Note: Caution should be exercised as this gasket is different from the **GS2** gasket for the split type manifolds.

### Sub-base for external pilot

**F18 ZG - 25 (Sub-base Rc1/4)**

**F18 ZG - 25H (Sub-base NPT1/4)**

### Connector-related order codes

**FZ -**

**Valve specification**  
 For **T1, T2, T3, T4, T5**

**Connector specification**

- CP** : Connector, lead wire length 300 mm [11.8 in.] (black, red, white, for total of 3 lead wires)
- CP3** : Connector, lead wire length 3000 mm [118 in.] (black, red, white, for total of 3 lead wires)
- CLN** : Connector without lead wire (1 short bar and 3 contacts included)
- CC1.5** : Cabtyre cable length 1500 mm [59 in.]<sup>\*</sup>
- CC3** : Cabtyre cable length 3000 mm [118 in.]<sup>\*</sup>

<sup>\*</sup>For details, see p. 19.

**FZ0 -**

**Valve specification**  
 For **T0**

**Connector specification**

- CP** : Connector, lead wire length 300 mm [11.8 in.] (black, red, for total of 2 lead wires)
- CP3** : Connector, lead wire length 3000 mm [118 in.] (black, red, for total of 2 lead wires)
- CLN** : Connector without lead wire (1 short bar, 2 contacts included)

# F18 Series Monoblock Manifold A Type (Base Piping Type) Order Codes

## Valve size

**F18M**

18 mm [0.709 in.] width

## Manifold outlet specification

With dual use fitting blocks (base piping type)

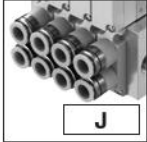

Outlet port fitting  
φ 8, φ 10

With selectable fittings (base piping type)

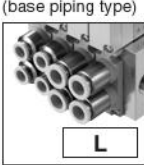

Outlet port should be selected in accordance with the manifold fitting specification.

With female thread blocks (base piping type)

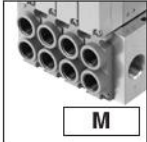

Outlet port female thread  
Rc1/4

## Valve specification

- T0: 2-position, for single solenoid only
- T1: 2-position, single solenoid specification
- T2: 2-position, double solenoid specification
- T3: 3-position, closed center
- T4: 3-position, exhaust center<sup>Note6</sup>
- T5: 3-position, pressure center<sup>Note6</sup>

## Pilot specification

**Blank**

Internal pilot manifold

**G**

External pilot manifold

## Operation type

**Blank**

Internal pilot type<sup>Note4</sup>

**G**

External pilot type<sup>Note5</sup>  
(for positive pressure)

**V**

External pilot type<sup>Note5</sup>  
(for vacuum)<sup>\*</sup>  
<sup>\*</sup> This is a vacuum valve.  
Note: Cannot be mounted together with a positive pressure valve.

## Manual override

Manual override button



No protrusion with DIN connector

Manual override lever<sup>Note2</sup>



Protruding locking type<sup>Note7</sup>



## Valve outlet type

With plate<sup>Note3</sup>  
(base piping type)

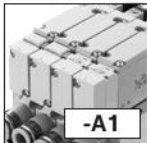

## Wiring specification

L type plug connector  
Without connector



S type plug connector  
Without connector



S type plug connector  
Lead wire 300 mm<sup>\*</sup>



L type plug connector  
Lead wire 300 mm<sup>\*</sup>



S type plug connector  
Lead wire 3000 mm<sup>\*</sup>



L type plug connector  
Lead wire 3000 mm<sup>\*</sup>



Pre-wired positive common terminal  
S type plug connector  
Lead wire 300 mm<sup>\*</sup>

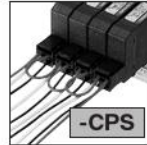

Pre-wired positive common terminal  
L type plug connector  
Lead wire 300 mm<sup>\*</sup>

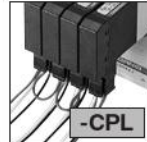

Pre-wired positive common terminal  
S type plug connector  
Lead wire 3000 mm<sup>\*</sup>

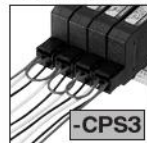

Pre-wired positive common terminal  
L type plug connector  
Lead wire 3000 mm<sup>\*</sup>

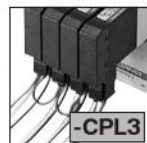

DIN connector type with indicator<sup>Note9</sup>



DIN connector type without connector<sup>Note9</sup>

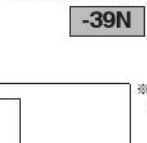

## Individual air supply and exhaust spacer

- Blank : No spacer
- NP8 : Individual air supply spacer (with φ 8 fitting)<sup>Note11</sup>
- NP0 : Individual air supply spacer (with φ 10 fitting)<sup>Note11</sup>
- NR8 : Individual exhaust spacer (with φ 8 fitting)<sup>Note11</sup>
- NR0 : Individual exhaust spacer (with φ 10 fitting)<sup>Note11</sup>

For details, see p. 25.

## Manifold fitting specification

- J5 : With single use φ 8 fitting block<sup>Note9</sup> (base piping type)
- J6 : With single use φ 10 fitting block<sup>Note9</sup> (base piping type)
- MH : With female thread NPT1/4 block<sup>Note10</sup> (base piping type)

<sup>\*</sup> 300 mm = 11.8 in.  
<sup>\*</sup> 3000 mm = 118 in.

Valve size	Valve units	Manifold type	Manifold outlet specification	Pilot specification	Station	Valve size	Valve specification	Operation type	Manual override	Valve outlet type	Wiring specification	Manifold fitting specification	Individual air supply and exhaust spacer	Voltage
Manifold model				Mounting valve model										
F18M	2 ⋮ 20	A	J M	Blank G	stn. 1 ⋮ stn. □ <sup>Note 1</sup>	F18	T0 T1 T2 T3 T4 <sup>Note6</sup> T5 <sup>Note6</sup>	Blank <sup>Note4</sup> G <sup>Note5</sup> V <sup>Note5</sup>	Blank -R <sup>Note2</sup>	-A1 <sup>Note3</sup>	Blank -PN -PS -PL -PS3 -PL3	-CPS -CPL -CPS3 -CPL3	Blank -NP8 <sup>Note11</sup> -NP0 <sup>Note11</sup> -NR8 <sup>Note11</sup> -NR0 <sup>Note11</sup>	DC24V DC12V AC100V
		A AH	L	Blank G	stn. 1 ⋮ stn. □ <sup>Note 1</sup>	F18	T0 T1 T2 T3 T4 <sup>Note6</sup> T5 <sup>Note6</sup>	Blank <sup>Note4</sup> G <sup>Note5</sup> V <sup>Note5</sup>	Blank -R <sup>Note2</sup> -83 <sup>Note7</sup>	-A1 <sup>Note3</sup>	Blank -PN -PS -PL -PS3 -PL3	-CPS -CPL -CPS3 -CPL3 -39L <sup>Note8</sup> -39N <sup>Note8</sup>	-J5 <sup>Note9</sup> -J6 <sup>Note9</sup> -MH <sup>Note10</sup>	Blank -NP8 <sup>Note11</sup> -NP0 <sup>Note11</sup> -NR8 <sup>Note11</sup> -NR0 <sup>Note11</sup>

- Notes: 1. Valve mounting location is from the left, with the solenoid on top, and the 4(A), 2(B) ports side in front.  
2. When the valve specification is T1 or T2, the manual override lever is placed only on the A side. This is not available with -39□.  
3. Always enter -A1.  
4. Cannot be mounted on the external pilot manifold.  
5. Cannot be mounted on the internal pilot manifold.

6. Not available in the vacuum valves.  
7. Only for wiring specification -39□.  
8. Not available for valve specification T1. In addition, the valve is used only as a double solenoid for T2.  
9. Can be selected only when the manifold type is A.  
10. Can be selected only when the manifold type is AH.  
11. Not available with DIN connectors (-39□).

Remark: Negative common specifications are also available as made to order products (add -129W to the ends of the valve and manifold model order codes). For details, consult us.

# F18 Series Monoblock Manifold A Type Additional Parts Order Codes

## Gasket (gasket and exhaust valve)

**F18 Z - GS1**

## Individual air supply and exhaust spacer (Spacer for non-plug-in type, gasket, exhaust valve, and 2 mounting screws)

**F18 Z -**

### Specification

- NP8** : Individual air supply spacer (with  $\phi$  8 fitting)
- NP0** : Individual air supply spacer (with  $\phi$  10 fitting)
- NR8** : Individual exhaust spacer (with  $\phi$  8 fitting)
- NR0** : Individual exhaust spacer (with  $\phi$  10 fitting)

※For details, see p. 25.  
 ※Not available with DIN connectors (-39).

## Block-off plate (block-off plate and 2 mounting screws)

**F18 BP**

## Connector-related order codes

**FZ**  -

### Valve specification

**Blank**: For **T1, T2, T3, T4, T5**  
**0**: For **T0**

### Connector specification

- CP** : Connector, lead wire length 300 mm [11.8 in.]
- CP3** : Connector, lead wire length 3000 mm [118 in.]
- CLN** : Connector without lead wire (short bar and contacts included)
- PA** : Positive common A type, lead wire length 300 mm [11.8 in.]※
- PA3** : Positive common A type, lead wire length 3000 mm [118 in.]※
- PB** : Positive common B type, lead wire length 300 mm [11.8 in.]※
- PB3** : Positive common B type, lead wire length 3000 mm [118 in.]※
- PC** : Positive common C type, lead wire length 300 mm [11.8 in.]※
- PC3** : Positive common C type, lead wire length 3000 mm [118 in.]※
- CC1.5** : Cabtyre cable, length 1500 mm [59 in.]<sup>Note</sup> ※
- CC3** : Cabtyre cable, length 3000 mm [118 in.]<sup>Note</sup> ※

※For details, see p. 19.

Note: Not available for **T0**

## Muffler

**KM - J**

### Fitting size

- 8**: Outer diameter  $\phi$  8 (for individual exhaust spacer)
  - 10**: Outer diameter  $\phi$  10 (for individual exhaust spacer)
- (Sales unit: Set of 10 mufflers)

## Common connector assembly

### A type: FZ-PA※

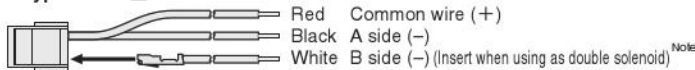

### B type: FZ-PB※

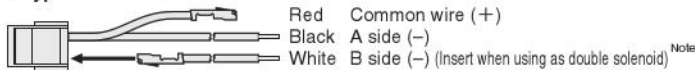

### C type: FZ-PC※

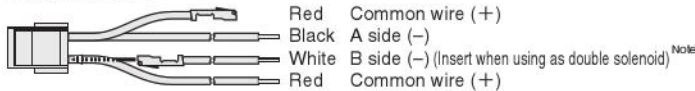

※ Lead wire length **Blank**: 300 mm [11.8 in.] Note: White lead wire is not available for **FZ0-P**.  
**3**: 3000 mm [118 in.]

## Manifold Order Code Example

(6 units of F18 Series)

**F18M6AL**

- stn.1~2 F18T0-A1-PS-J5 DC24V
- stn.3~5 F18T2-A1-PS-J6 DC24V
- stn.6 F18BP-J6

## Precautions for Order Codes

### Manifold outlet specification

Select from among "dual use fitting blocks", "with female thread blocks" or "with selectable fittings." For repair or replacement, purchase the single valve unit additional parts, **F18Z-J** (dual use fitting block), **F18Z-J**  (single use fitting block), or **F18Z-M**  (female thread block), on p. 73.

### Orders for valves only

Place orders from "F18 Series Single Valve Unit Order Codes" on p. 72. Note, however, that the only available valve outlet type is **A1**. In addition, for common terminal wiring connections, order the common connector assemblies listed above separately.

# F18 Series Monoblock Manifold F Type (Direct Piping Type) Order Codes

## Valve size

**F18M**

18 mm [0.709 in.] width

## Valve specification

- T0**: 2-position, for single solenoid only
- T1**: 2-position, single solenoid specification
- T2**: 2-position, double solenoid specification
- T3**: 3-position, closed center
- T4**: 3-position, exhaust center
- T5**: 3-position, pressure center

## Manual override

Manual override button



**Blank**

No protrusion with DIN connector

Manual override lever <sup>Note2</sup>



**-R**

Protruding locking type <sup>Note3</sup>



**-83**

## Valve outlet type

**-FJ**

With dual use  $\phi$  8,  $\phi$  10 fitting block <sup>Note5</sup> (direct piping type)

**-FJ5**

With single use  $\phi$  8 fitting block <sup>Note5</sup> (direct piping type)

**-FJ6**

With single use  $\phi$  10 fitting block <sup>Note5</sup> (direct piping type)

**-FM**

With Rc1/4 female thread block <sup>Note5</sup> (direct piping type)

**-FMH**

With NPT 1/4 female thread block <sup>Note6</sup> (direct piping type)

## Wiring specification

L type plug connector Without connector



**Blank**

S type plug connector Without connector



**-PN**

S type plug connector Lead wire 300 mm <sup>\*</sup>

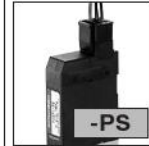

**-PS**

L type plug connector Lead wire 300 mm <sup>\*</sup>



**-PL**

S type plug connector Lead wire 3000 mm <sup>\*</sup>



**-PS3**

L type plug connector Lead wire 3000 mm <sup>\*</sup>



**-PL3**

Pre-wired positive common terminal S type plug connector Lead wire 300 mm <sup>\*</sup>

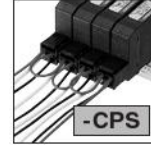

**-CPS**

Pre-wired positive common terminal L type plug connector Lead wire 300 mm <sup>\*</sup>

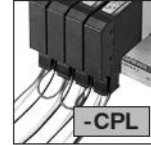

**-CPL**

Pre-wired positive common terminal S type plug connector Lead wire 3000 mm <sup>\*</sup>

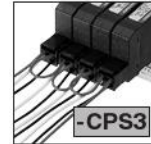

**-CPS3**

Pre-wired positive common terminal L type plug connector Lead wire 3000 mm <sup>\*</sup>

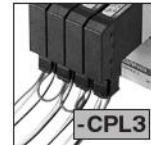

**-CPL3**

<sup>\*</sup> 300 mm = 11.8 in.  
3000 mm = 118 in.

## Individual air supply and exhaust spacer

- Blank**: No spacer
  - NP8**: Individual air supply spacer (with  $\phi$  8 fitting) <sup>Note7</sup>
  - NP0**: Individual air supply spacer (with  $\phi$  10 fitting) <sup>Note7</sup>
  - NR8**: Individual exhaust spacer (with  $\phi$  8 fitting) <sup>Note7</sup>
  - NR0**: Individual exhaust spacer (with  $\phi$  10 fitting) <sup>Note7</sup>
- For details, see p. 25.

Valve size	Valve units	Manifold type	Station	Valve size	Valve specification	Manual override	Valve outlet type	Wiring specification	Individual air supply and exhaust spacer	Voltage	
Manifold model			Mounting valve model								
F18M	2 . . . 20	F FH	stn. 1 . . . stn. □ <sup>Note1</sup>	F18	T0 T3 T1 T4 T2 T5	Blank -R <sup>Note2</sup> -83 <sup>Note3</sup>	-FJ <sup>Note5</sup> -FJ5 <sup>Note5</sup> -FJ6 <sup>Note5</sup> -FM <sup>Note5</sup> -FMH <sup>Note6</sup>	Blank -PN -PS -PL -PS3 -PL3	-CPS -CPL -CPS3 -CPL3 -39L <sup>Note4</sup> -39N <sup>Note4</sup>	Blank -NP8 <sup>Note7</sup> -NP0 <sup>Note7</sup> -NR8 <sup>Note7</sup> -NR0 <sup>Note7</sup>	DC24V DC12V AC100V <sup>Note7</sup> AC120V AC240V <sup>Note3</sup>
<b>BP</b> (for block-off plate)											

Notes: 1. Valve mounting location is from the left, with the solenoid on top, and the 4(A), 2(B) ports side in front.  
2. When the valve specification is **T1** or **T2**, the manual override lever is placed only on the A side. This is not available with **-39□**.  
3. Only for wiring specification **-39□**.

4. Not available for valve specification **T1**. In addition, the valve is used only as a double solenoid for **T2**.  
5. Can be selected only when the manifold type is **F**.  
6. Can be selected only when the manifold type is **FH**.  
7. Not available with DIN connectors (**-39□**).

Remarks: 1. The external pilot valve cannot be mounted on the F type manifold.  
2. Negative common specifications are also available as made to order products (add **-129W** to the ends of the valve and manifold model order codes). For details, consult us.

# F18 Series Monoblock Manifold F Type Additional Parts Order Codes

## Gasket (gasket and exhaust valve)

**F18 Z - GS1**

## Individual air supply and exhaust spacer (Spacer for non-plug-in type, gasket, exhaust valve, and 2 mounting screws)

**F18 Z -**

### Specification

- NP8** : Individual air supply spacer (with  $\phi$  8 fitting)
- NP0** : Individual air supply spacer (with  $\phi$  10 fitting)
- NR8** : Individual exhaust spacer (with  $\phi$  8 fitting)
- NR0** : Individual exhaust spacer (with  $\phi$  10 fitting)

## Block-off plate (block-off plate and 2 mounting screws)

**F18 BP**

※For details, see p. 25.

※Not available with DIN connectors (-39).

## Connector-related order codes

**FZ**  -

### Valve specification

Blank: For **T1, T2, T3, T4, T5**  
0: For **T0**

### Connector specification

- CP** : Connector, lead wire length 300 mm [11.8 in.]
- CP3** : Connector, lead wire length 3000 mm [118 in.]
- CLN** : Connector without lead wire (short bar and contacts included)
- PA** : Positive common A type, lead wire length 300 mm [11.8 in.]※
- PA3** : Positive common A type, lead wire length 3000 mm [118 in.]※
- PB** : Positive common B type, lead wire length 300 mm [11.8 in.]※
- PB3** : Positive common B type, lead wire length 3000 mm [118 in.]※
- PC** : Positive common C type, lead wire length 300 mm [11.8 in.]※
- PC3** : Positive common C type, lead wire length 3000 mm [118 in.]※
- CC1.5** : Cabtyre cable, length 1500 mm [59 in.]<sup>Note</sup>※
- CC3** : Cabtyre cable, length 3000 mm [118 in.]<sup>Note</sup>※

※For details, see p. 19.

Note: Not available for **T0**

## Muffler

**KM - J**

### Fitting size

- 8**: Outer diameter  $\phi$  8 (for individual exhaust spacer)
  - 10**: Outer diameter  $\phi$  10 (for individual exhaust spacer)
- (Sales unit: Set of 10 mufflers)

## Common connector assembly

### A type: FZ-PA※

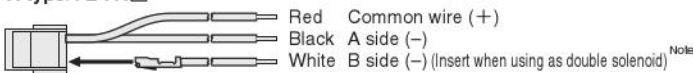

### B type: FZ-PB※

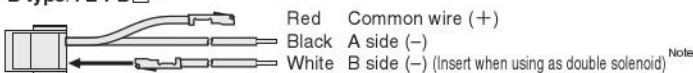

### C type: FZ-PC※

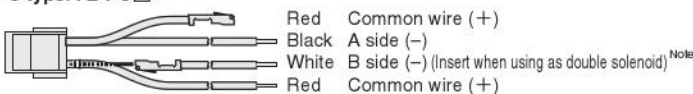

※ Lead wire length **Blank**: 300 mm [11.8 in.] **3**: 3000 mm [118 in.] **Note**: White lead wire is not available for **FZ0-P**.

## Manifold Order Code Example

(4 units of F18 Series)

**F18M4F**

- stn.1~2 **F18T0-FJ5-PS DC24V**
- stn.3 **F18T2-FJ6-PS DC24V**
- stn.4 **F18BP**

## Precautions for Order Codes

### Orders for valves only

Place orders from "F18 Series Single Valve Unit Order Codes" on p. 72.

Select from valve outlet types **-FJ**, **-FJ5**, **-FJ6**, or **-FM**. In addition, for common terminal wiring connections, order the common connector assemblies listed above separately.

# F18 Series Split Manifold Non-Plug-in Type Order Codes

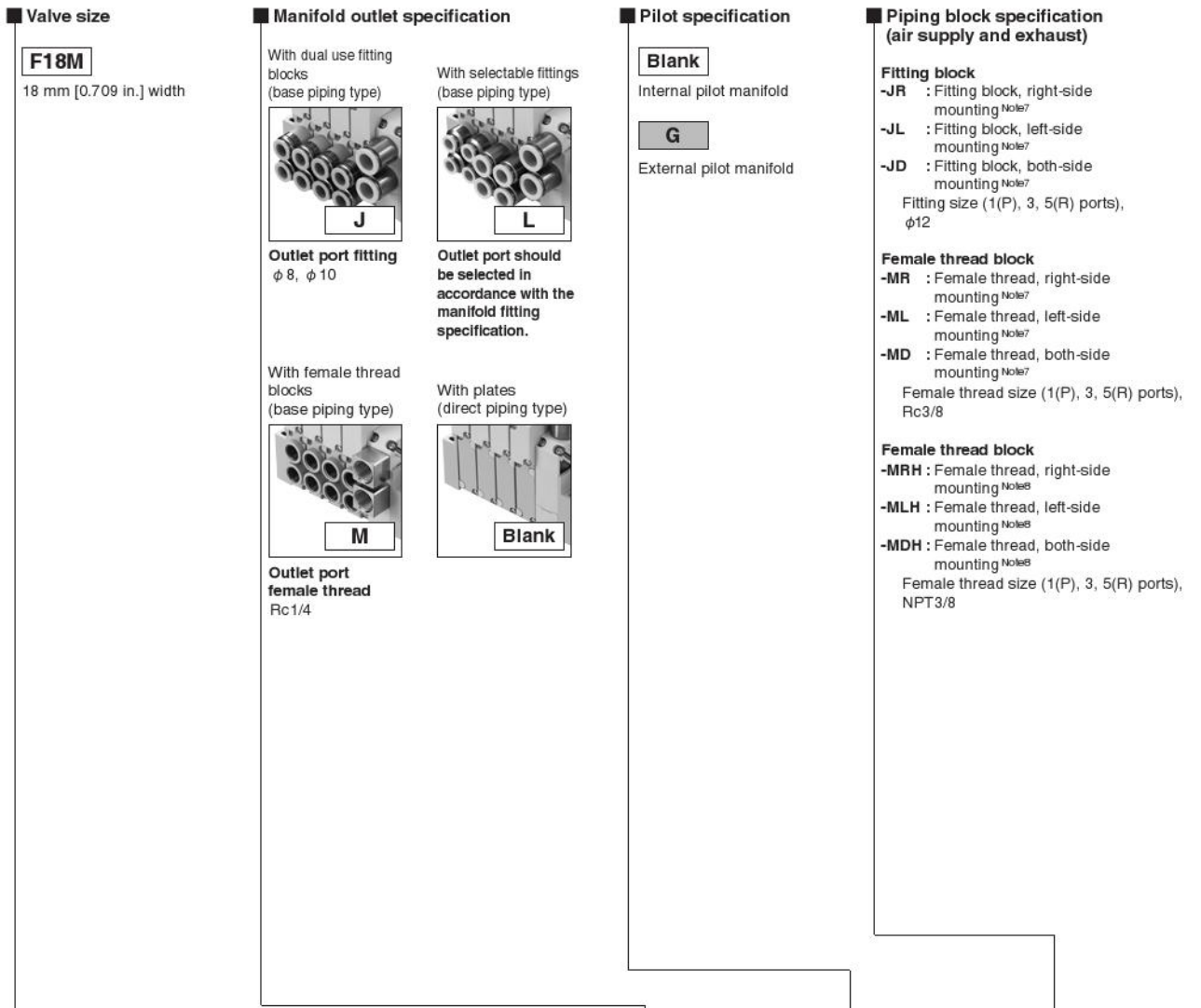

Valve size	Valve units	Manifold type	Manifold outlet specification	Pilot specification	Piping block specification
Manifold model					

Base piping type	F18M	2 ⋮ 20	N	J M	Blank G	-JR -JL -JD	-MR -ML -MD	
Base piping type selectable fitting			N NH	L	Blank G	-JR <sup>Note7</sup> -JL <sup>Note7</sup> -JD <sup>Note7</sup>	-MR <sup>Note7</sup> -ML <sup>Note7</sup> -MD <sup>Note7</sup>	-MRH <sup>Note8</sup> -MLH <sup>Note8</sup> -MDH <sup>Note8</sup>
Direct piping type			Blank	Blank G	-JR <sup>Note7</sup> -JL <sup>Note7</sup> -JD <sup>Note7</sup>	-MR <sup>Note7</sup> -ML <sup>Note7</sup> -MD <sup>Note7</sup>	-MRH <sup>Note8</sup> -MLH <sup>Note8</sup> -MDH <sup>Note8</sup>	

Remark: Negative common specifications are also available as made to order products (add **-129W** to the ends of the valve and manifold model order codes). For details, consult us.

**Valve specification**

- T0** : 2-position, for single solenoid only
- T1** : 2-position, single solenoid specification
- T2** : 2-position, double solenoid specification
- T3** : 3-position, closed center
- T4** : 3-position, exhaust center
- T5** : 3-position, pressure center

**Operation type**

- Blank**  
Internal pilot type<sup>Note5</sup>
- G**  
External pilot type<sup>Note6</sup>  
(for positive pressure)  
※ No vacuum valve can be mounted.

**Valve outlet type**

- A1** With plate<sup>Note3</sup>  
(base piping type)
- FJ** With dual use  $\phi$  8,  $\phi$  10 fitting block<sup>Note7</sup>  
(direct piping type)
- FJ5** With single use  $\phi$  8 fitting block<sup>Note7</sup> (direct piping type)
- FJ6** With single use  $\phi$  10 fitting block<sup>Note7</sup> (direct piping type)
- FM** With Rc 1/4 female thread block<sup>Note7</sup> (direct piping type)
- FMH** With NPT 1/4 female thread block<sup>Note8</sup> (direct piping type)

**Manual override**



**Wiring specification**



**Manifold fitting specification**

- J5** With single use  $\phi$  8 fitting block<sup>Note7</sup>  
(base piping type)
- J6** With single use  $\phi$  10 fitting block<sup>Note7</sup>  
(base piping type)
- MH** With NPT 1/4 female thread block<sup>Note8</sup>  
(base piping type)

**Individual air supply and exhaust spacer**

- Blank** : No spacer
  - NP8** : Individual air supply spacer (with  $\phi$  8 fitting)
  - NP0** : Individual air supply spacer (with  $\phi$  10 fitting)
  - NR8** : Individual exhaust spacer (with  $\phi$  8 fitting)
  - NR0** : Individual exhaust spacer (with  $\phi$  10 fitting)
- For details, see p. 25.

**Port isolator**

- Blank** : No port isolator
- SP** : For 1(P) port<sup>Note4</sup>
- SR** : For 3(R2), 5(R1) ports<sup>Note4</sup>
- SA** : For 1(P), 3(R2), and 5(R1) ports<sup>Note4</sup>

Station	Valve size	Valve specification	Operation type	Manual override	Valve outlet type	Wiring specification	Manifold fitting specification	Individual air supply and exhaust spacer	Port Isolator	Voltage
---------	------------	---------------------	----------------	-----------------	-------------------	----------------------	--------------------------------	--	---------------	---------

Mounting valve model										
stn. 1 ⋮ stn. □ <small>Note 1</small>	F18	T0 T3	Blank <sup>Note5</sup>	Blank	-A1 <sup>Note3</sup>	-PN -PS -PS3 -CPS -CPS3	-J5 <sup>Note7</sup> -J6 <sup>Note7</sup> -MH <sup>Note8</sup>	Blank -NP8 -NR8 -NP0 -NR0	Blank -SP <sup>Note4</sup> -SR <sup>Note4</sup> -SA <sup>Note4</sup>	DC24V DC12V AC100V AC120V
		T1 T4	G <sup>Note6</sup>	-R <sup>Note2</sup>						
stn. 1 ⋮ stn. □ <small>Note 1</small>	F18	T0 T3	Blank <sup>Note5</sup>	Blank	-A1 <sup>Note3</sup>	-PN -PS -PS3 -CPS -CPS3	-J5 <sup>Note7</sup> -J6 <sup>Note7</sup> -MH <sup>Note8</sup>	Blank -NP8 -NR8 -NP0 -NR0	Blank -SP <sup>Note4</sup> -SR <sup>Note4</sup> -SA <sup>Note4</sup>	DC24V DC12V AC100V AC120V
		T1 T4	G <sup>Note6</sup>	-R <sup>Note2</sup>						
stn. 1 ⋮ stn. □ <small>Note 1</small>	F18	T0 T3	Blank <sup>Note5</sup>	Blank	-FJ <sup>Note7</sup> -FJ5 <sup>Note7</sup> -FJ6 <sup>Note7</sup> -FM <sup>Note7</sup> -FMH <sup>Note8</sup>	-PN -PS -PS3 -CPS -CPS3	-J5 <sup>Note7</sup> -J6 <sup>Note7</sup> -MH <sup>Note8</sup>	Blank -NP8 -NR8 -NP0 -NR0	Blank -SP <sup>Note4</sup> -SR <sup>Note4</sup> -SA <sup>Note4</sup>	DC24V DC12V AC100V AC120V
		T1 T4	G <sup>Note6</sup>	-R <sup>Note2</sup>						
stn. 1 ⋮ stn. □ <small>Note 1</small>	F18	T0 T3	Blank <sup>Note5</sup>	Blank	-A1 <sup>Note3</sup>	-PN -PS -PS3 -CPS -CPS3	-J5 <sup>Note7</sup> -J6 <sup>Note7</sup> -MH <sup>Note8</sup>	Blank -NP8 -NR8 -NP0 -NR0	Blank -SP <sup>Note4</sup> -SR <sup>Note4</sup> -SA <sup>Note4</sup>	DC24V DC12V AC100V AC120V
		T1 T4	G <sup>Note6</sup>	-R <sup>Note2</sup>						

Notes: 1. Valve mounting location is from the left, with the solenoid on top, and the 4(A), 2(B) ports side in front.  
 2. When the valve specification is T1 or T2, the manual override lever is placed only on the A side.  
 3. When selecting J, M, or L (base piping type) for the manifold outlet specification, always enter -A1 (with plate) for the valve outlet type.  
 4. Port isolators can be installed only when piping blocks are mounted on both sides. In addition, only 1 port isolator can be mounted in 1 manifold for -SA, or 1 each port isolator for -SP and -SR for a total of 2 locations. When shipping, the designated port isolators are mounted between the designated station and the station to its immediate left (the next smaller stn. No.).  
 5. Cannot be mounted on the external pilot manifold.  
 6. Cannot be mounted on the internal pilot manifold.  
 7. Can be selected only when the manifold type is N.  
 8. Can be selected only when the manifold type is NH.

# F18 Series Split Manifold Non-Plug-in Type Additional Parts Order Codes

## Parts for manifold

**F18 Z** -

### Parts content

- GS2** : Gasket (gasket and exhaust valve)
- SP** : Port isolator (for 1(P) port)
- SR** : Port isolator (for 3(R2), 5(R1) ports)
- SA** : Port isolator (for 1(P), 3(R2), 5(R1) ports)

## Piping block assembly

**F18 Z**  -

### Piping specification

- PJ** : Fitting piping block
- PM** : Rc3/8 female thread piping block
- PMH** : NPT3/8 female thread piping block

### Pilot specification

- Blank** : Internal pilot
- G** : External pilot

## Block-off plate (block-off plate, 2 mounting screws)

**F18 BP N**

For non-plug-in type

## End blocks (one set of left and right)

**F18 Z - E**

## Connector-related order codes

**FZ**  -

300 mm = 11.8 in.  
1500 mm = 59 in.  
3000 mm = 118 in.

### Valve specification

**Blank**: For T1, T2, T3, T4, T5  
**0**: For T0

※For details, see p. 19.

### Connector specification

- CP** : Connector, lead wire length 300 mm
- CP3** : Connector, lead wire length 3000 mm
- CLN** : Connector without lead wire (short bar, contacts included)
- PA** : Positive common A type, lead wire length 300 mm \*
- PA3** : Positive common A type, lead wire length 3000 mm \*
- PB** : Positive common B type, lead wire length 300 mm \*
- PB3** : Positive common B type, lead wire length 3000 mm \*
- PC** : Positive common C type, lead wire length 300 mm \*
- PC3** : Positive common C type, lead wire length 3000 mm \*
- CC1.5** : Cabtyre cable, length 1500 mm <sup>Note</sup> \*
- CC3** : Cabtyre cable, length 3000 mm <sup>Note</sup> \*

Note: Not available for T0

## Individual air supply and exhaust spacer (Spacer for non-plug-in type, gasket, exhaust valve, and 2 mounting screws)

**F18 Z** -

### Specification

- NP8** : Individual air supply spacer (with  $\phi$  8 fitting)
- NP0** : Individual air supply spacer (with  $\phi$  10 fitting)
- NR8** : Individual exhaust spacer (with  $\phi$  8 fitting)
- NR0** : Individual exhaust spacer (with  $\phi$  10 fitting)

※For details, see p. 25.

## Muffler

**KM - J**

### Fitting size

- 8**: Outer diameter  $\phi$  8 (for individual exhaust spacer)
  - 10**: Outer diameter  $\phi$  10 (for individual exhaust spacer)
  - 12**: Outer diameter  $\phi$  12
- (Sales unit: Set of 10 mufflers)

## Common connector assembly

### A type: FZ-PA ※

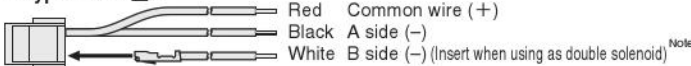

### B type: FZ-PB ※

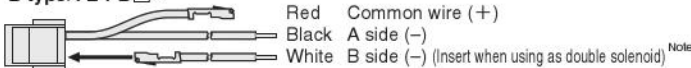

### C type: FZ-PC ※

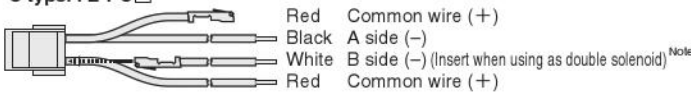

※ Lead wire length **Blank**: 300 mm [11.8 in.] **3**: 3000 mm [118 in.] Note: White lead wire is not available for FZ0-P  .

## Connecting rod

**F18 Z** -  -

### Additional unit number

- 01~20 (01~04 for RH)**
- ※For reduction of units, consult us.

### Specification

- RV** : For valve base
- RH** : For piping and wiring base

## Valve base assembly (valve base and gasket)

**F18 Z** -

### Piping specification

- VJ** : Dual use fitting valve base
- VJ5** : Single use  $\phi$  8 fitting valve base
- VJ6** : Single use  $\phi$  10 fitting valve base
- VM** : Rc1/4 female thread valve base
- VMH** : NPT1/4 female thread valve base
- VP** : Valve base plate

## Manifold Order Code Example

(4 units of F18 Series)

### F18M4NL-JR

- stn.1~2 F18T0-A1-PS-J5 DC24V
- stn.3 F18T2-A1-PS-J6 DC24V
- stn.4 F18BPN-J6

## Precautions for Order Codes

### Orders for valves only

Place orders from "F18 Series Single Valve Unit Order Codes" on p. 72. However, **Blank**, **A2**, **F3**, **F4**, **F5**, and **F6**, cannot be selected for the valve outlet type. And for the wiring specification, **Blank**, **PL**, and **PL3** cannot be selected. In addition, for common terminal wiring connections, separately order the common connector assemblies listed on the left.



# F18 Series Split Manifold Plug-in Type Order Codes

## Manifold outlet specification

With dual use fitting blocks (base piping type)

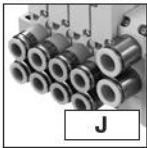

**J**

Outlet port fitting  
φ 8, φ 10

With selectable fittings (base piping type)

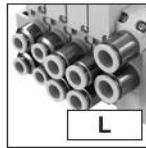

**L**

Outlet port should be selected in accordance with the manifold fitting specification.

With female thread blocks (base piping type)

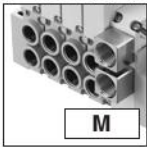

**M**

Outlet port female thread  
Rc 1/4

With plates (direct piping type)

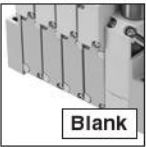

**Blank**

## Valve size

**F18M**

18 mm [0.709 in.] width

## Pilot specification

**Blank**

Internal pilot manifold

**G**

External pilot manifold

## Piping block specification (air supply and exhaust)

### Fitting block

**-JR** : Fitting block, right-side mounting <sup>Note11</sup>

**-JL** : Fitting block, left-side mounting <sup>Note11</sup>

**-JD** : Fitting block, both-side mounting <sup>Note11</sup>

Fitting size (1(P), 3, 5(R) ports), φ 12

### Female thread block

**-MR** : Female thread, right-side mounting <sup>Note11</sup>

**-ML** : Female thread, left-side mounting <sup>Note11</sup>

**-MD** : Female thread, both-side mounting <sup>Note11</sup>

Female thread size (1(P), 3, 5(R) ports), Rc3/8

### Female thread block

**-MRH** : Female thread, right-side mounting <sup>Note12</sup>

**-MLH** : Female thread, left-side mounting <sup>Note12</sup>

**-MDH** : Female thread, both-side mounting <sup>Note12</sup>

Female thread size (1(P), 3, 5(R) ports), NPT3/8

## Wiring specification (wiring block)

Flat cable connector (with socket and strain relief)

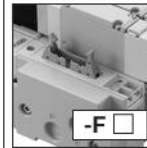

**-F**

**-F100** : 10-pin  
**-F101** : 10-pin  
**-F200** : 20-pin  
**-F201** : 20-pin  
**-F260** : 26-pin  
For details, see p. 92-96.

Terminal block (19 terminals, M3 screws)

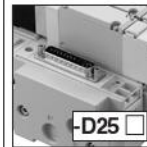

D-sub connector

**-D25**

(M2.6 mounting screws)

**-D250** : 25-pin <sup>Note11</sup>

**-D251** : 25-pin <sup>Note11</sup>

(4-40UNC mounting screws)

**-D250U** : 25-pin <sup>Note12</sup>

**-D251U** : 25-pin <sup>Note12</sup>

**-D370NU** : 37-pin, no-power terminal <sup>Note12</sup>

For details, see p. 92-96.



**-T200**

Also can provide the terminal block with cover. <sup>Note3</sup>

## Wiring connection specification

**Blank**

**Packed wiring**: Wiring is made in accordance with the mounted valve specifications.

**-W**

**Double wiring**: Wiring is always for the double solenoid, regardless of the specifications of the mounted valve.

## Wiring position (wiring block)

**Blank**: Left-side mounting

**-R** : Right-side mounting

Valve size	Valve units	Manifold type	Manifold outlet specification	Pilot specification	Piping block specification	Wiring specification	Wiring connection specification	Wiring position	Voltage
Manifold model									

Base piping type	F18M	2 ⋮ □ <sup>Note1</sup>	P	J M	Blank G	-JR -MR -JL -ML -JD -MD	-F100 -D250 -F101 -D251 -F200 -T200 -F201 -F260	Blank -W	Blank -R	DC24V DC12V AC100V <sup>Note2</sup> AC120V <sup>Note2</sup>
Base piping type selectable fitting			L	Blank G	-JR <sup>Note11</sup> -MD <sup>Note11</sup> -JL <sup>Note11</sup> -MRH <sup>Note12</sup> -JD <sup>Note11</sup> -MLH <sup>Note12</sup> -MR <sup>Note11</sup> -MDH <sup>Note12</sup> -ML <sup>Note11</sup>	-F100 -D251 <sup>Note11</sup> -F101 -D250U <sup>Note12</sup> -F200 -D251U <sup>Note12</sup> -F201 -D370NU <sup>Note12</sup> -F260 -T200 -D250 <sup>Note11</sup>	Blank -W	Blank -R	DC24V DC12V AC100V <sup>Note2</sup> AC120V <sup>Note2</sup>	
Direct piping type			PH	Blank	Blank G	-JR <sup>Note11</sup> -MD <sup>Note11</sup> -JL <sup>Note11</sup> -MRH <sup>Note12</sup> -JD <sup>Note11</sup> -MLH <sup>Note12</sup> -MR <sup>Note11</sup> -MDH <sup>Note12</sup> -ML <sup>Note11</sup>	-F100 -D251 <sup>Note11</sup> -F101 -D250U <sup>Note12</sup> -F200 -D251U <sup>Note12</sup> -F201 -D370NU <sup>Note12</sup> -F260 -T200 -D250 <sup>Note11</sup>	Blank -W	Blank -R	DC24V DC12V AC100V <sup>Note2</sup> AC120V <sup>Note2</sup>

Notes: 1. For the maximum number of units, see the table for maximum number of valve units by wiring specification, on p. 84.  
2. AC100V, AC120V is available only for the -D250 □, -D251 □, -D370NU (D-sub connector) and -T200 (terminal block) wiring specifications.  
3. The terminal block with cover is also available as a made to order product (add -139W to the end of the manifold model order code).  
For details, consult us.

Remark: Negative common specifications are also available as made to order products (add -129W to the ends of the valve and manifold model order codes).  
For details, consult us.

**Valve specification**

- T0** : 2-position, for single solenoid only
- T1** : 2-position, single solenoid specification
- T2** : 2-position, double solenoid specification
- T3** : 3-position, closed center
- T4** : 3-position, exhaust center
- T5** : 3-position, pressure center

**Operation type**

**Blank**

Internal pilot type <sup>Note9</sup>

**G**

External pilot type <sup>Note10</sup>  
(for positive pressure)  
※ No vacuum valve can be mounted.

**Valve outlet type**

- A1** With plate <sup>Note5</sup>  
(base piping type)
- FJ** With dual use  $\phi$  8,  $\phi$  10 fitting block <sup>Note11</sup>  
(direct piping type)
- FJ5** With single use  $\phi$  8 fitting block <sup>Note11</sup>  
(direct piping type)
- FJ6** With single use  $\phi$  10 fitting block <sup>Note11</sup>  
(direct piping type)
- FM** With Rc1/4 female thread block <sup>Note11</sup>  
(direct piping type)
- FMH** With NPT1/4 female thread block <sup>Note12</sup>  
(direct piping type)

**Manual override**

Manual override button



Manual override lever <sup>Note7</sup>



**Manifold fitting specification**

- J5** With single use  $\phi$  8 fitting block <sup>Note11</sup>  
(base piping type)
- J6** With single use  $\phi$  10 fitting block <sup>Note11</sup>  
(base piping type)
- MH** With NPT1/4 female thread block <sup>Note12</sup>  
(base piping type)

**Individual air supply and exhaust spacer**

- Blank** : No spacer
  - PP8** : Individual air supply spacer  
(with  $\phi$  8 fitting)
  - PP0** : Individual air supply spacer  
(with  $\phi$  10 fitting)
  - PR8** : Individual exhaust spacer  
(with  $\phi$  8 fitting)
  - PR0** : Individual exhaust spacer  
(with  $\phi$  10 fitting)
- For details, see p. 25.

**Port isolator**

- Blank** : No port isolator
- SP** : For 1(P) port <sup>Note8</sup>
- SR** : For 3(R2), 5(R1) ports <sup>Note8</sup>
- SA** : For 1(P), 3(R2), 5(R1) ports <sup>Note8</sup>

Station	Valve size	Valve specification	Operation type	Manual override	Valve outlet type	Manifold fitting specification	Individual air supply and exhaust spacer	Port isolator	Voltage
<b>Mounting valve model</b>									
stn. 1 ⋮ stn. □ <small>Note4</small>	F18	T0 T3 T1 T4 T2 T5	Blank <sup>Note9</sup> G <sup>Note10</sup>	Blank -R <sup>Note7</sup>	-A1 <sup>Note5</sup>		Blank -PP8 -PR8 -PP0 -PR0	Blank -SP <sup>Note8</sup> -SR <sup>Note8</sup> -SA <sup>Note8</sup>	DC24V DC12V AC100V <sup>Note2</sup> AC120V <sup>Note2</sup>
		<b>BPP (for block-off plate)<sup>Note6</sup></b>							
stn. 1 ⋮ stn. □ <small>Note4</small>	F18	T0 T3 T1 T4 T2 T5	Blank <sup>Note9</sup> G <sup>Note10</sup>	Blank -R <sup>Note7</sup>	-A1 <sup>Note5</sup>	-J5 <sup>Note11</sup> -J6 <sup>Note11</sup> -MH <sup>Note12</sup>	Blank -PP8 -PR8 -PP0 -PR0	Blank -SP <sup>Note8</sup> -SR <sup>Note8</sup> -SA <sup>Note8</sup>	DC24V DC12V AC100V <sup>Note2</sup> AC120V <sup>Note2</sup>
		<b>BPP (for block-off plate)<sup>Note6</sup></b>							
stn. 1 ⋮ stn. □ <small>Note4</small>	F18	T0 T3 T1 T4 T2 T5	Blank <sup>Note9</sup> G <sup>Note10</sup>	Blank -R <sup>Note7</sup>	-FJ <sup>Note11</sup> -FJ5 <sup>Note11</sup> -FJ6 <sup>Note11</sup> -FM <sup>Note11</sup> -FMH <sup>Note12</sup>		Blank -PP8 -PR8 -PP0 -PR0	Blank -SP <sup>Note8</sup> -SR <sup>Note8</sup> -SA <sup>Note8</sup>	DC24V DC12V AC100V <sup>Note2</sup> AC120V <sup>Note2</sup>
		<b>BPP (for block-off plate)<sup>Note6</sup></b>							

Notes: 4. Valve mounting location is from the left, with the solenoid on top, and the 4(A), 2(B) ports side in front.  
 5. When selecting J, M, or L (base piping type) for the manifold outlet specification, always enter -A1 (with plate) for the valve outlet type.  
 6. Caution should be exercised that the block-off plate wiring is always double wiring (allocated 2 control pins at 1 stn.), regardless of the wiring connection specification. For wiring for a single solenoid, see p. 85.  
 7. When the valve specification is T1 or T2, the manual override lever is placed only on the A side.  
 8. Port isolators can be installed only when piping blocks are mounted on both sides. In addition, only 1 port isolator can be mounted in 1 manifold for -SA, or 1 each port isolator for -SP and -SR for a total of 2 locations. When shipping, the designated port isolators are mounted between the designated station and the station to its immediate left (the next smaller stn. No.).  
 9. Cannot be mounted on the external pilot manifold.  
 10. Cannot be mounted on the internal pilot manifold.  
 11. Can be selected only when the manifold type is P.  
 12. Can be selected only when the manifold type is PH.

# F18 Series Split Manifold Plug-in Type Additional Parts Order Codes

## Parts for manifold

**F18 Z** -

**Parts content**

- GS2** : Gasket (gasket and exhaust valve)
- SP** : Port isolator (for 1(P) port)
- SR** : Port isolator (for 3(R2), 5(R1) ports)
- SA** : Port isolator (for 1(P), 3(R2), 5(R1) ports)

## Block-off plate (block-off plate, 2 mounting screws, and plug)

**F18 BP P**

For plug-in type

## Valve base assembly (valve base, gasket, lead wire, and plug-in connector)

**F18 Z** -  -

**Wiring specification**

- D**: For D-sub connector
- F**: For flat cable connector, terminal block

**Piping specification**

- VJ** : Dual use fitting valve base
- VJ5** : Single use  $\phi$  8 fitting valve base
- VJ6** : Single use  $\phi$  10 fitting valve base
- VM** : Rc3/8 female thread valve base
- VMH** : NPT1/4 female thread valve base
- VP** : Valve base plate

## Piping block assembly

**F18 Z**  -

**Piping specification**

- PJP** : Fitting piping block
- PMP** : Rc3/8 female thread piping block
- PMPH** : NPT3/8 female thread piping block

**Pilot specification**

- Blank** : Internal pilot
- G** : External pilot

## End blocks (one set of left and right)

**F18 Z** - **EP**

## Wiring block assembly (one set)

**F18 Z** -  -

**Voltage (Not required for T200)**

- DC24**
- DC12**
- AC100** (for **D250** , **D251** , **D370NU** only)

**Piping specification**

- F100** : Flat cable connector (DC specification)
- F101** : Flat cable connector (DC specification)
- F200** : Flat cable connector (DC specification)
- F201** : Flat cable connector (DC specification)
- F260** : Flat cable connector (DC specification)
- D250** : D-sub connector (M2.6 screws)
- D251** : D-sub connector (M2.6 screws)
- D250U** : D-sub connector (4-40UNC screws)
- D251U** : D-sub connector (4-40UNC screws)
- D370NU** : D-sub connector (4-40UNC screws), without power terminal
- T200L** : Terminal block for left-side mounting
- T200R** : Terminal block for right-side mounting

## Individual air supply and exhaust spacer (Spacer for plug-in type, gasket, exhaust valve, and 2 mounting screws)

**F18 Z** -

**Specification**

- PP8** : Individual air supply spacer (with  $\phi$  8 fitting)
- PP0** : Individual air supply spacer (with  $\phi$  10 fitting)
- PR8** : Individual exhaust spacer (with  $\phi$  8 fitting)
- PR0** : Individual exhaust spacer (with  $\phi$  10 fitting)

※For details, see p. 25.

## Muffler

**KM** - **J**

**Fitting size**

- 8**: Outer diameter  $\phi$  8 (for individual exhaust spacer)
  - 10**: Outer diameter  $\phi$  10 (for individual exhaust spacer)
  - 12**: Outer diameter  $\phi$  12
- (Sales unit: Set of 10 mufflers)

## Connecting rod

**F18 Z** -  -

**Number of additional units**

- 01~20 (01~04 for RH)**
- ※Example: To add 2 valve units, enter **-02**.
- ※For reduction of units, consult us.

**Specification**

- RV** : For valve base
- RH** : For piping and wiring base

## Table for maximum number of valve units by wiring specification

		Maximum number of units	
		Wiring connection specification	
Wiring specification	Max. outputs	Packed wiring (Blank)	Double wiring (-W)
<b>F100</b> Flat cable (10P)	8	Varies depending on the number of mounted single solenoids, double solenoids, and block-off plates. The number of controlled solenoids should be designated as the maximum number of outputs or less. <b>D370NU</b> is a maximum of 20 units.	4 units
<b>F101</b> Flat cable (10P)	8		4 units
<b>F200</b> Flat cable (20P)	16		8 units
<b>F201</b> Flat cable (20P)	16		8 units
<b>F260</b> Flat cable (26P)	20		10 units
<b>D250</b> <input type="checkbox"/> D-sub connector (25P)	16		8 units
<b>D251</b> <input type="checkbox"/> D-sub connector (25P)	20		10 units
<b>D370NU</b> D-sub connector (37P)	32		16 units
<b>T200</b> Terminal block (19 terminals)	18		9 units

## Manifold Order Code Example

(12 units of F18 Series)

### F18M12PL-JR-F201 DC24V

stn.1~8 F18T0-A1-J5 DC24V  
stn.9~11 F18T2-A1-J6 DC24V  
stn.12 F18BPP-J6

## Precautions for Order Codes

### ● Orders for valves only

Place orders from "F18 Series Single Valve Unit Order Codes" on p. 72.

However, **Blank**, **A2**□, **F3**, **F4**□, **F5**, and **F6** cannot be selected for the valve outlet type. For the wiring specification, **Blank** is the only selection.

### ● Wiring connection specification

**Blank** (packed wiring): Wiring is made in accordance with the mounted valve specifications.

**-W** (double wiring): Wiring is always for the double solenoid, regardless of the specifications of the mounted valve.

### Caution

Caution should be exercised that the block-off plate wiring is always double wiring (allocated 2 control pins at 1 stn.), regardless of the wiring connection specification. The block-off plate wiring can be made as wiring for a single solenoid. Add **-1W** to the end of the block-off plate order code in the case. For details, consult us.

# F18 Series Serial Transmission Compatible Manifold Order Codes

## Manifold outlet specification

With dual use fitting blocks (base piping type)

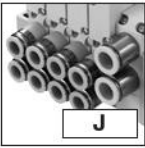

Outlet port fitting  
φ 8, φ 10

With selectable fittings (base piping type)

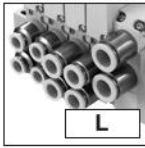

Outlet port should be selected in accordance with the manifold fitting specification.

With female thread blocks (base piping type)

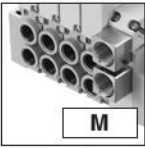

Outlet port female thread  
Rc 1/4

With plates (direct piping type)

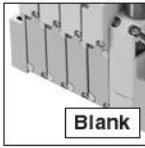

Blank

## Valve size

**F18M**

18 mm [0.709 in.] width

## Pilot specification

**Blank**

Internal pilot manifold

**G**

External pilot manifold

## Piping block specification (air supply and exhaust)

### Fitting block

**-JR** : Fitting block, right-side mounting <sup>Note10</sup>

**-JL** : Fitting block, left-side mounting <sup>Note10</sup>

**-JD** : Fitting block, both-side mounting <sup>Note10</sup>

Fitting size (1(P), 3, 5(R) ports), φ12

### Female thread block

**-MR** : Female thread, right-side mounting <sup>Note10</sup>

**-ML** : Female thread, left-side mounting <sup>Note10</sup>

**-MD** : Female thread, both-side mounting <sup>Note10</sup>

Female thread size (1(P), 3, 5(R) ports), Rc3/8

### Female thread block

**-MRH** : Female thread, right-side mounting <sup>Note11</sup>

**-MLH** : Female thread, left-side mounting <sup>Note11</sup>

**-MDH** : Female thread, both-side mounting <sup>Note11</sup>

Female thread size (1(P), 3, 5(R) ports), NPT3/8

## Transmission block specification

※ These are the serial transmission block specifications compatible with each system.



● Block photoed on right is compatible with CompoNet. For details, see p. 37, 40.

**-31** : For OMRON B7A Link Terminal (standard)

**-32** : For OMRON B7A Link Terminal (high speed)

**-A1** : For OMRON CompoBus/S (16 outputs)

**-B1** : For CC-Link (16 outputs)

**-H1** : For CompoNet (16 outputs) <sup>Note2</sup>

## Wiring connection specification

**Blank**

**Packed wiring**: Wiring is made in accordance with the mounted valve specifications.

**-W**

**Double wiring**: Wiring is always for the double solenoid, regardless of the specifications of the mounted valve.

## Wiring position (transmission block)

**Blank** : Left-side mounting

**-R** : Right-side mounting <sup>Note2</sup>

Valve size	Valve units	Manifold type	Manifold outlet specification	Pilot specification	Piping block specification	Transmission block specification	Wiring connection specification	Wiring position
Manifold model								

Base piping type	F18M	2 ⋮ □ <sup>Note1</sup>	S	J M	Blank G	-JR -JL -JD	-MR -ML -MD	-31 -32	-A1 -B1 -H1 <sup>Note2</sup>	Blank -W	Blank -R <sup>Note2</sup>
Base piping type selectable fitting			L	Blank G	-JR <sup>Note10</sup> -JL <sup>Note10</sup> -JD <sup>Note10</sup> -MR <sup>Note10</sup> -ML <sup>Note10</sup>	-MD <sup>Note10</sup> -MRH <sup>Note11</sup> -MLH <sup>Note11</sup> -MDH <sup>Note11</sup>	-31 -32	-A1 -B1 -H1 <sup>Note2</sup>	Blank -W	Blank -R <sup>Note2</sup>	
Direct piping type			SH	Blank	Blank G	-JR <sup>Note10</sup> -JL <sup>Note10</sup> -JD <sup>Note10</sup> -MR <sup>Note10</sup> -ML <sup>Note10</sup>	-MD <sup>Note10</sup> -MRH <sup>Note11</sup> -MLH <sup>Note11</sup> -MDH <sup>Note11</sup>	-31 -32	-A1 -B1 -H1 <sup>Note2</sup>	Blank -W	Blank -R <sup>Note2</sup>

Notes: 1. To determine the maximum number of units, see the table for maximum number of valve units by transmission block specification, on p. 88.  
2. The -H1 (for CompoNet (16 outputs)) transmission block is mountable on the left side only.

**Valve specification**

- T0** : 2-position, for single solenoid only
- T1** : 2-position, single solenoid specification
- T2** : 2-position, double solenoid specification
- T3** : 3-position, closed center
- T4** : 3-position, exhaust center
- T5** : 3-position, pressure center

**Operation type**

- Blank**  
Internal pilot type <sup>Note8</sup>
- G**  
External pilot type <sup>Note9</sup>  
(for positive pressure)  
※ No vacuum valve can be mounted.

**Valve outlet type**

- A1** With plate <sup>Note4</sup>  
(base piping type)
- FJ** With dual use  $\phi$  8,  $\phi$  10 fitting block <sup>Note10</sup>  
(direct piping type)
- FJ5** With single use  $\phi$  8 fitting block <sup>Note10</sup>  
(direct piping type)
- FJ6** With single use  $\phi$  10 fitting block <sup>Note10</sup>  
(direct piping type)
- FM** With Rc1/4 female thread block <sup>Note10</sup>  
(direct piping type)
- FMH** With NPT1/4 female thread block <sup>Note11</sup>  
(direct piping type)

**Manual override**

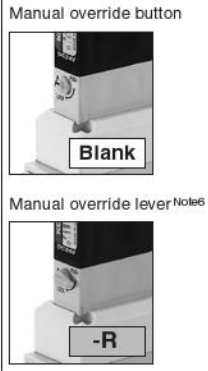

**Manifold fitting specification**

- J5** With single use  $\phi$  8 fitting block <sup>Note10</sup>  
(base piping type)
- J6** With single use  $\phi$  10 fitting block <sup>Note10</sup>  
(base piping type)
- MH** With NPT1/4 female thread block <sup>Note11</sup>  
(base piping type)

**Individual air supply and exhaust spacer**

- Blank** : No spacer
  - PP8** : Individual air supply spacer  
(with  $\phi$  8 fitting)
  - PP0** : Individual air supply spacer  
(with  $\phi$  10 fitting)
  - PR8** : Individual exhaust spacer  
(with  $\phi$  8 fitting)
  - PR0** : Individual exhaust spacer  
(with  $\phi$  10 fitting)
- For details, see p. 25.

**Port isolator**

- Blank** : No port isolator
- SP** : For 1(P) port <sup>Note7</sup>
- SR** : For 3(R2), 5(R1) ports <sup>Note7</sup>
- SA** : For 1(P), 3(R2), 5(R1) ports <sup>Note7</sup>

Station	Valve size	Valve specification	Operation type	Manual override	Valve outlet type	Manifold fitting specification	Individual air supply and exhaust spacer	Port isolator	Voltage
<b>Mounting valve model</b>									
stn. 1 ⋮ stn. □ <small>Note3</small>	F18	T0 T3 T1 T4 T2 T5	Blank <sup>Note8</sup> G <sup>Note9</sup>	Blank -R <sup>Note6</sup>	-A1 <sup>Note4</sup>		Blank -PP8 -PR8 -PP0 -PR0	Blank -SP <sup>Note7</sup> -SR <sup>Note7</sup> -SA <sup>Note7</sup>	DC24V
		<b>BPP (for block-off plate)<sup>Note5</sup></b>							
stn. 1 ⋮ stn. □ <small>Note3</small>	F18	T0 T3 T1 T4 T2 T5	Blank <sup>Note8</sup> G <sup>Note9</sup>	Blank -R <sup>Note6</sup>	-A1 <sup>Note4</sup>	-J5 <sup>Note10</sup> -J6 <sup>Note10</sup> -MH <sup>Note11</sup>	Blank -PP8 -PR8 -PP0 -PR0	Blank -SP <sup>Note7</sup> -SR <sup>Note7</sup> -SA <sup>Note7</sup>	DC24V
		<b>BPP (for block-off plate)<sup>Note5</sup></b>							
stn. 1 ⋮ stn. □ <small>Note3</small>	F18	T0 T3 T1 T4 T2 T5	Blank <sup>Note8</sup> G <sup>Note9</sup>	Blank -R <sup>Note6</sup>	-FJ <sup>Note10</sup> -FJ5 <sup>Note10</sup> -FJ6 <sup>Note10</sup> -FM <sup>Note10</sup> -FMH <sup>Note11</sup>		Blank -PP8 -PR8 -PP0 -PR0	Blank -SP <sup>Note7</sup> -SR <sup>Note7</sup> -SA <sup>Note7</sup>	DC24V
		<b>BPP (for block-off plate)<sup>Note5</sup></b>							

Notes: 3. Valve mounting location is from the left, with the solenoid on top, and the 4(A), 2(B) ports side in front.  
 4. When selecting J, M, or L (base piping type) for the manifold outlet specifications, always enter -A1 (with plate) for the valve outlet type.  
 5. Caution should be exercised that the block-off plate wiring is always double wiring (allocated 2 control pins at 1 stn.), regardless of the wiring connection specification. For wiring for a single solenoid, see p. 88.  
 6. When the valve specification is T1 or T2, the manual override lever is placed only on the A side.  
 7. Port isolators can be installed only when piping blocks are mounted on both sides. In addition, only 1 port isolator can be mounted in 1 manifold for -SA, or 1 each port isolator for -SP and -SR for a total of 2 locations. When shipping, the designated port isolators are mounted between the designated station and the station to its immediate left (the next smaller stn. No.).  
 8. Cannot be mounted on the external pilot manifold.  
 9. Cannot be mounted on the internal pilot manifold.  
 10. Can be selected only when the manifold type is S.  
 11. Can be selected only when the manifold type is SH.

# F18 Series Serial Transmission Compatible Manifold Additional Parts Order Codes

## Parts for manifold

**F18 Z** -

**Parts content**  
**GS2** : Gasket (gasket and exhaust valve)

## Block-off plate (block-off plate, 2 mounting screws, and plug)

**F18 BPP**

## Individual air supply and exhaust spacer (Spacer for plug-in type, gasket, exhaust valve, and 2 mounting screws)

**F18 Z** -

**Specification**  
**PP8** : Individual air supply spacer (with  $\phi$  8 fitting)  
**PP0** : Individual air supply spacer (with  $\phi$  10 fitting)  
**PR8** : Individual exhaust spacer (with  $\phi$  8 fitting)  
**PR0** : Individual exhaust spacer (with  $\phi$  10 fitting)

※For details, see p. 25.

## Serial transmission block (single unit)

**YS2**

**Wiring position**  
**S** : For integrated type, left-side mounting  
**T** : For integrated type, right-side mounting

### Transmission block specification

**31** : For OMRON B7A Link Terminal (standard)  
**32** : For OMRON B7A Link Terminal (high speed)

**A1** : For OMRON CompoBus/S (16 outputs)  
**B1** : For CC-Link (16 outputs)

**YS5H1U**

For CompoNet (16 outputs)  
 ※DIN rail included (length 75 mm [2.95 in.])

## Muffler

**KM - J**

**Fitting size**  
**8** : Outer diameter  $\phi$  8 (for individual exhaust spacer)  
**10** : Outer diameter  $\phi$  10 (for individual exhaust spacer)  
**12** : Outer diameter  $\phi$  12 (Sales unit: Set of 10 mufflers)

## Table for maximum number of valve units by transmission block specification

Transmission block specifications		Maximum number of units	
		Wiring connection specification	
	Max. outputs	Packed wiring (Blank)	Double wiring (-W)
-31 : For OMRON B7A Link Terminal (standard)	16	Varies depending on the number of mounted single solenoids, double solenoids, and block-off plates. The number of controlled solenoids should be designated as the maximum number of outputs or less.	8 units
-32 : For OMRON B7A Link Terminal (high speed)	16		8 units
-A1 : For OMRON CompoBus/S (16 outputs)	16		8 units
-B1 : For CC-Link (16 outputs)	16		8 units
-H1 : For CompoNet (16 outputs)	16		8 units
			8 units

### Manifold Order Code Example

(8 units of F18 Series)

**F18M8SL-JR-B1-W**

stn. 1~5 F18T0-A1-J5 DC24V  
 stn. 6~7 F18T2-A1-J6 DC24V  
 stn. 8 F18BPP-J6

## Precautions for Order Codes

### ● Orders for valves only

Place orders from "F18 Series Single Valve Unit Order Codes" on p. 72. However, **Blank**, **A2**, **F3**, **F4**, **F5**, and **F6**, cannot be selected for the valve outlet type. For the wiring specification, **Blank** is the only selection.

### ● Wiring connection specification

**Blank** (packed wiring): Wiring is made in accordance with the mounted valve specifications.  
**-W** (double wiring): Wiring is always for the double solenoid, regardless of the specifications of the mounted valve.

### Caution

Caution should be exercised that the block-off plate wiring is always double wiring (allocated 2 control pins at 1 stn.), regardless of the wiring connection specification. The block-off plate wiring can be made as wiring for a single solenoid. Add **-1W** to the end of the block-off plate order code in the case. For details, consult us.



# PC Board Manifold Pin Locations by Wiring Specification (Top View)

## Flat cable connector (20-pin)

● **-F200** (Maximum number of control pins: 16)

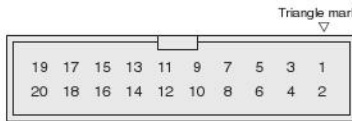

1 ~ 16 : Control pins  
 17, 18 : ( - ) pins (Short-circuited inside)  
 19, 20 : ( + ) pins (Short-circuited inside)

● **-F201** (Maximum number of control pins: 16)

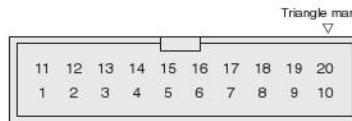

1 ~ 8 : Control pins  
 11 ~ 18 : Control pins  
 9, 19 : ( - ) pins (Short-circuited inside)  
 10, 20 : ( + ) pins (Short-circuited inside)

Caution : Connector pin numbers are assigned for the sake of convenience.  
 Use the ▽ mark as the reference.

Remark : The **-F201** corresponds to Koganei's pin locations for the PC wiring system (wire-saving unit). For details, see the Valves General Catalog.

● Various dedicated cable assemblies are available. See p. 103, 104 for details.

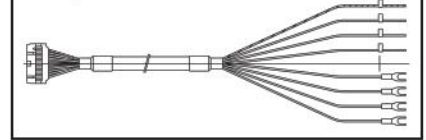

Remark: Socket and strain relief for flat cable are included at shipping.

※ For the relationship between the pin No. (terminal No.) and the corresponding solenoid, see p.91.

## Detailed Diagram of Wiring System

### ● Positive common

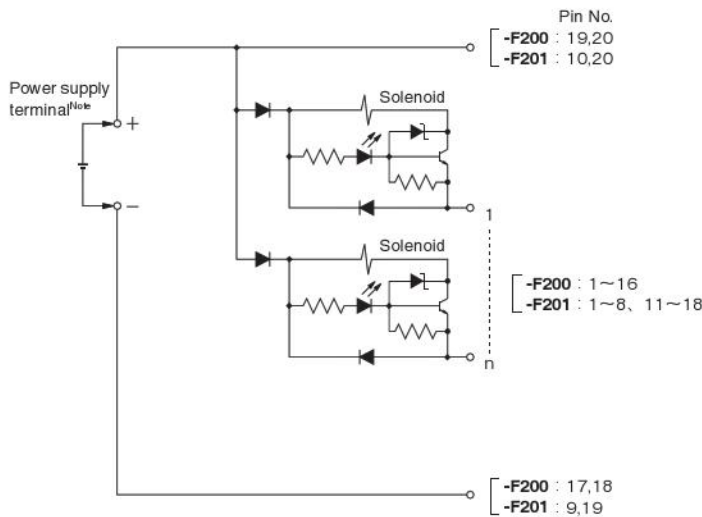

Note: For connecting a power line to the PC board manifold power terminal, see the "PC Board Manifold" precautions on p.21.

Remark: The internal circuit is of the standard type. For details of the low-current type, see p.20, 21.

## Pin No. and Corresponding Solenoid (For PC Board Manifold A Type and F Type)

The examples below show the relationship between the PC board manifold pin No. and the corresponding solenoid.  
All the mounting examples show cases of the maximum number of control pins used.

### Flat cable connector (20-pin)

● In the case of wiring specification **-F200** (Maximum number of control pins: 16)

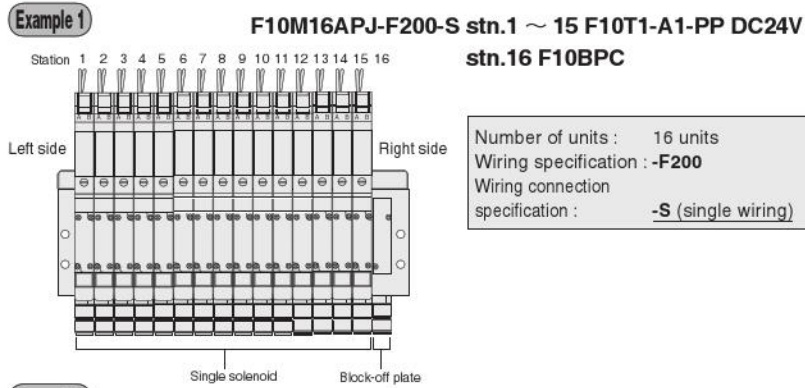

(Top View) Triangle mark ▼

19	17	15	13	11	9	7	5	3	1
20	18	16	14	12	10	8	6	4	2

Pin No.	19	17	15	13	11	9	7	5	3	1
Valve No.	+	-	15A	13A	11A	9A	7A	5A	3A	1A
Pin No.	20	18	16	14	12	10	8	6	4	2
Valve No.	+	-	16A	14A	12A	10A	8A	6A	4A	2A

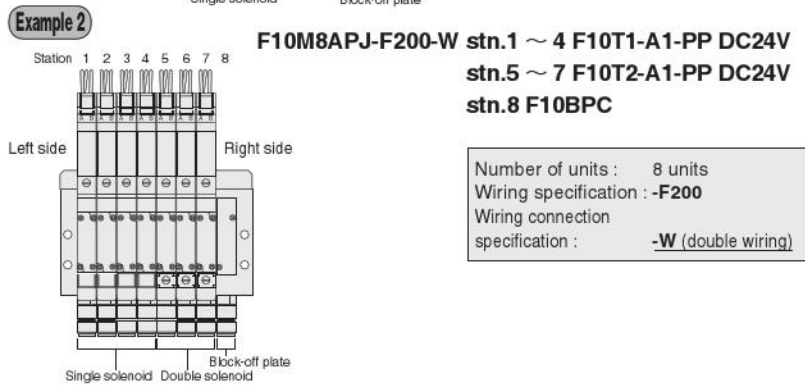

(Top View) Triangle mark ▼

19	17	15	13	11	9	7	5	3	1
20	18	16	14	12	10	8	6	4	2

Pin No.	19	17	15	13	11	9	7	5	3	1
Valve No.	+	-	8A	7A	6A	5A	4A	3A	2A	1A
Pin No.	20	18	16	14	12	10	8	6	4	2
Valve No.	+	-	8B	7B	6B	5B	4B	3B	2B	1B

### Flat cable connector (20-pin)

● In the case of wiring specification **-F201** (Maximum number of control pins: 16)

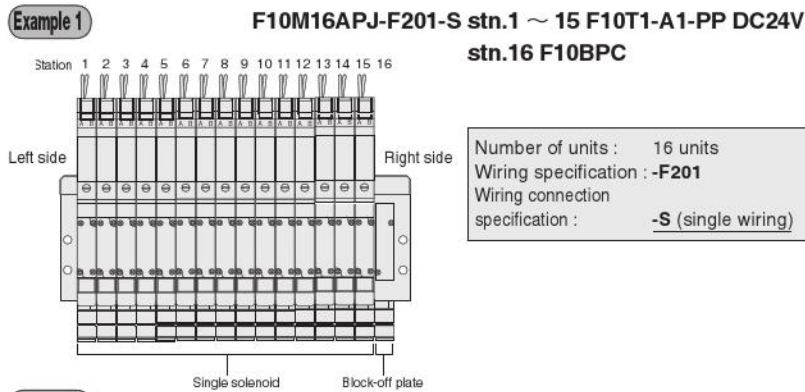

(Top View) Triangle mark ▼

11	12	13	14	15	16	17	18	19	20
1	2	3	4	5	6	7	8	9	10

Pin No.	11	12	13	14	15	16	17	18	19	20
Valve No.	9A	10A	11A	12A	13A	14A	15A	16A	-	+
Pin No.	1	2	3	4	5	6	7	8	9	10
Valve No.	1A	2A	3A	4A	5A	6A	7A	8A	-	+

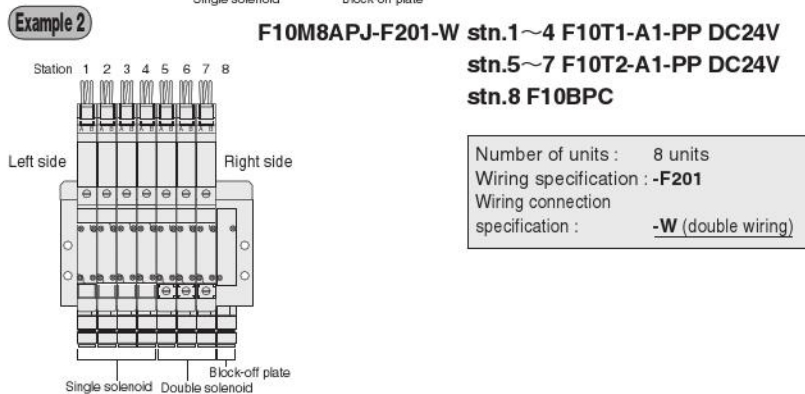

(Top View) Triangle mark ▼

11	12	13	14	15	16	17	18	19	20
1	2	3	4	5	6	7	8	9	10

Pin No.	11	12	13	14	15	16	17	18	19	20
Valve No.	5A	5B	6A	6B	7A	7B	8A	8B	-	+
Pin No.	1	2	3	4	5	6	7	8	9	10
Valve No.	1A	1B	2A	2B	3A	3B	4A	4B	-	+

**Caution:** Connector pin numbers are assigned for the sake of convenience.  
Use the ▼ mark as the reference.

Notes: 1. The valve No.1A, 1B, 2A, 2B... numerals show the stn. numbers in order, while the letters A and B show the A and B sides of the solenoid.  
2. The stn. numbers are counted from the left, 1, 2... with the solenoid on top and the valve in front.

# Pin (Terminal) Locations by Wiring Specification (Top View) (For Monoblock Manifold A Type and F Type Wire-Saving Type, Split Manifold Plug-in Type)

## Flat cable connector (10-pin)

●-F100□□ (Maximum number of control pins: 8)

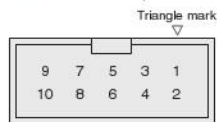

1~8 : Control pins  
9, 10 : Common pins (short-circuited within the wiring block)

●-F101□□ (Maximum number of control pins: 8)

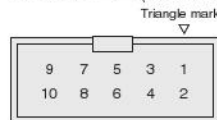

1~8 : Control pins  
9 : (-) pin <sup>Note</sup>  
10 : (+) pin

Note: For no-power terminal type, set to NC (unused pin).

## Flat cable connector (20-pin)

●-F200□□ (Maximum number of control pins: 16)

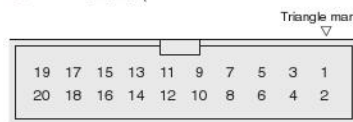

1~16 : Control pins  
17, 18 : (-) pins (short-circuited within the wiring block)<sup>Note</sup>  
19, 20 : (+) pins (short-circuited within the wiring block)  
Note: For no-power terminal type, set to NC (unused pin).

●-F201□□ (Maximum number of control pins: 16)

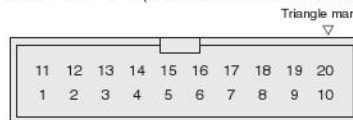

1~8 : Control pins  
11~18 : Control pins  
9, 19 : (-) pins (short-circuited within the wiring block)<sup>Note</sup>  
10, 20 : (+) pins (short-circuited within the wiring block)

Note: For no-power terminal type, set to NC (unused pin).

**Caution:** Connector pin numbers are assigned for the sake of convenience.  
Use the ▽ mark as the reference.

Remark : The -F201 corresponds to Koganei's pin locations for the PC wiring system (wire-saving unit). For details, see the Valves General Catalog.

## D-sub connector (25-pin)

●-D250□□ (Maximum number of control pins: 16)

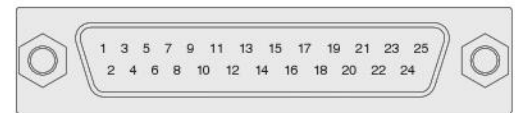

1~16 : Control pins  
20, 21, 22 : (-) pins (short-circuited within the wiring block)<sup>Note</sup>  
23, 24, 25 : (+) pins (short-circuited within the wiring block)  
Note: For no-power terminal type, set to NC (unused pin).

**Caution:** The above pin numbers are assigned based on the solenoid valve wiring sequence for the sake of convenience.

They differ from the pin locations and pin numbers (marking) prescribed (JIS-X5101) for the Data Circuit-terminating Equipment (DCE).

●-D251□□ Pin locations based on JIS (Maximum number of control pins: 20)

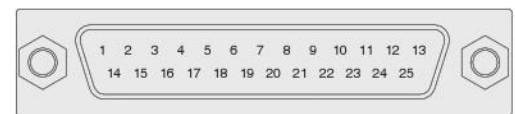

1~10, 14~23 : Control pins  
12, 13 : (-) pins (short-circuited within the wiring block)<sup>Note</sup>  
24, 25 : (+) pins (short-circuited within the wiring block)  
Note: For no-power terminal type, set to NC (unused pin).

## Flat cable connector (26-pin)

●-F260□□ (Maximum number of control pins: 20)

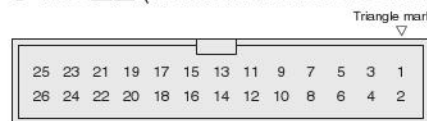

1~20 : Control pins  
23, 24 : (-) pins (short-circuited within the wiring block)<sup>Note</sup>  
25, 26 : (+) pins (short-circuited within the wiring block)  
Note: For no-power terminal type, set to NC (unused pin).

## D-sub connector (37-pin)

●-D370NU (Maximum number of control pins: 32)

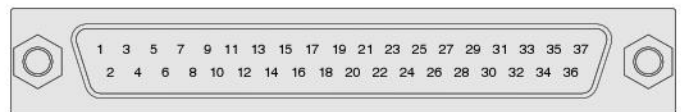

1~32 : Control pin  
36, 37 : Common pin (For positive common)

**Caution:** The above pin numbers are assigned based on the solenoid valve wiring sequence for the sake of convenience.  
They differ from the pin locations and pin numbers (marking) prescribed (JIS-X5103) for the Data Circuit-terminating Equipment (DCE).

● Various dedicated cable assemblies are available. See p. 103, 104 for details.

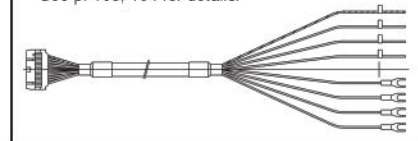

## Terminal block type (19 terminals, M3 screws)

●-T200 (Maximum number of control pins: 18)



1~18 : Control terminals  
COM : Common terminal

**Caution:** Apply the tightening torque for the terminal screw (M3) to 49.0 N·cm [4.3 in·lbf] or less.

※ For the relationship between the pin No.(terminal No.) and the corresponding solenoid, see p. 97- 102.

# F10, F15 Series Detailed Diagram of Wiring System

## Flat cable connector and D-sub connector (12VDC and 24VDC)

### ● Positive common

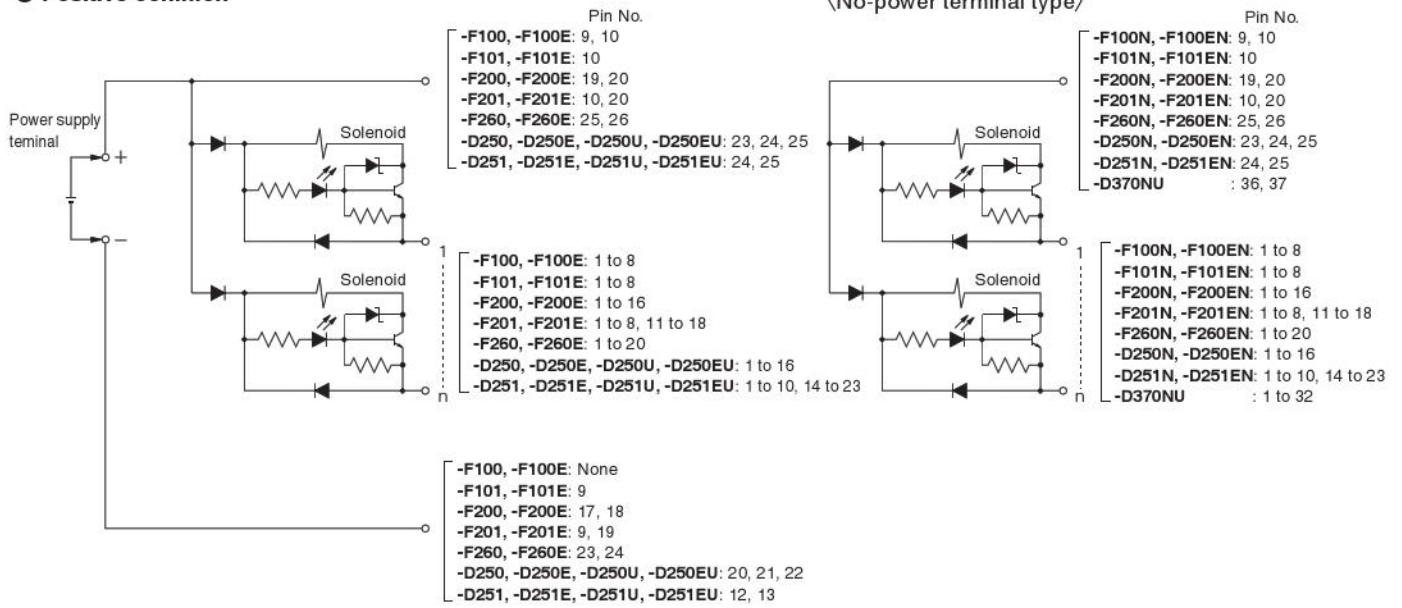

### ● Negative common (-129W)

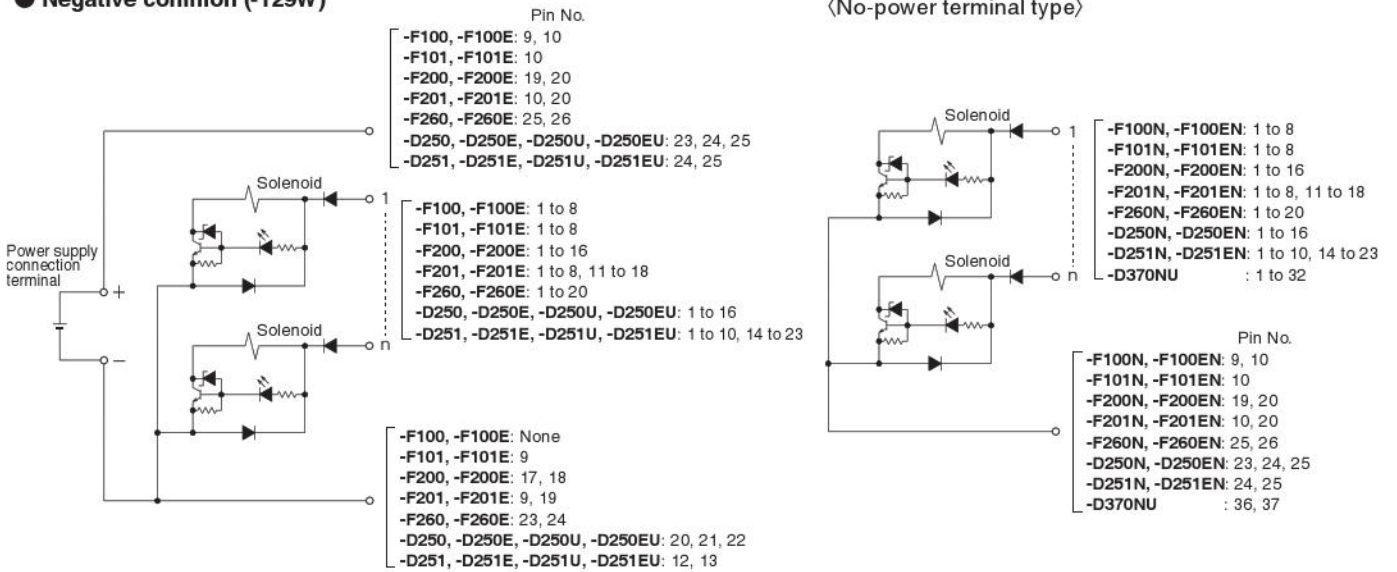

# F10, F15 Series Detailed Diagram of Wiring System

## D-sub connector (For 100VAC and 120VAC specification)

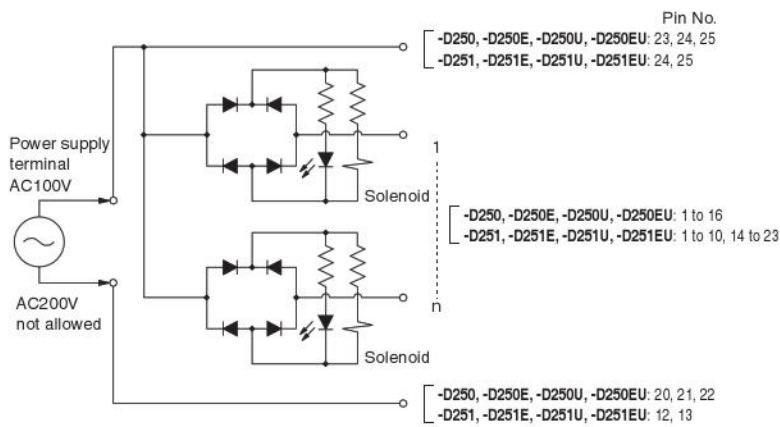

### <No-power terminal type>

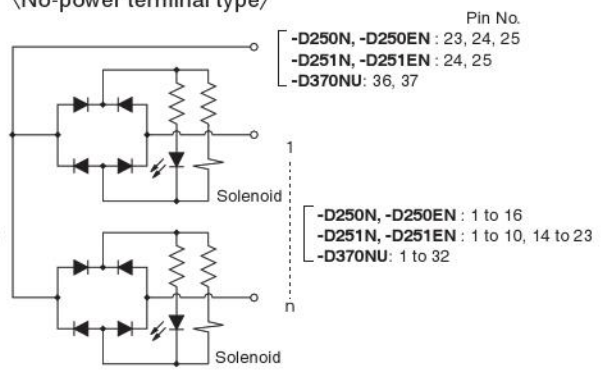

## Terminal block (For 12VDC and 24VDC specifications)

### ● Positive common

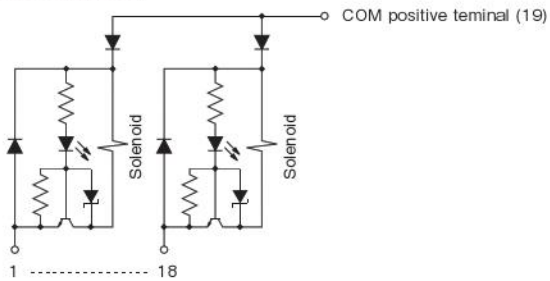

### ● Negative common (-129W)

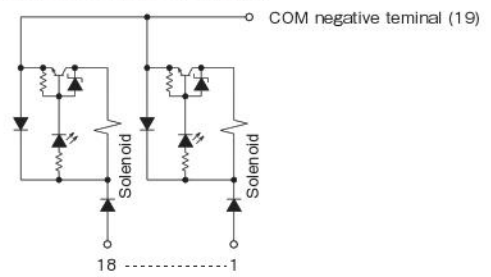

## Terminal block (For 100VAC and 120VAC specification)

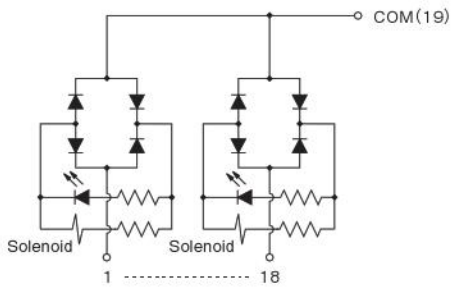

Remark: The internal circuit is of the standard type. For details of the low-current type, see p.20, 21.

# F18 Series Detailed Diagram of Wiring System

## Flat cable connector and D-sub connector (12VDC and 24VDC)

### ● Positive common

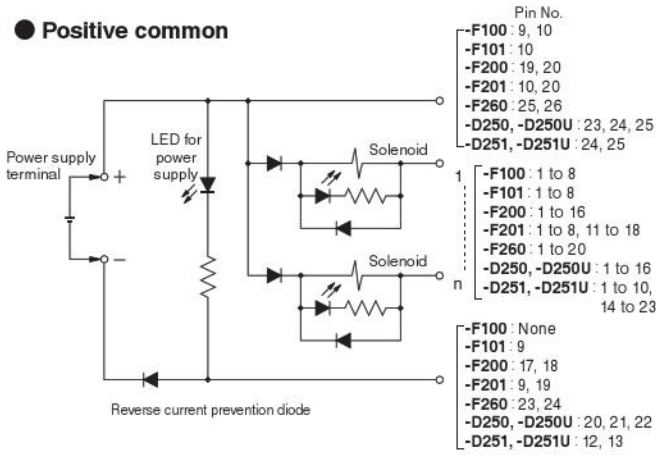

### ● Negative common (-129W)

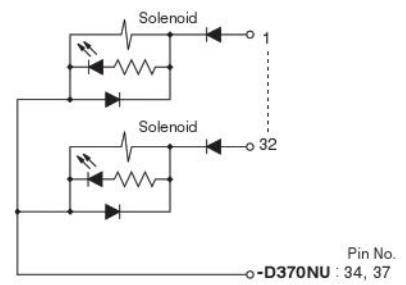
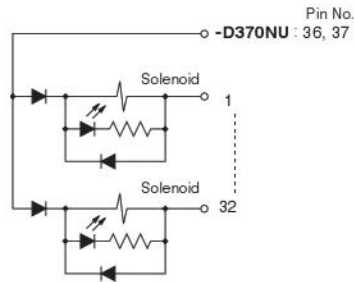
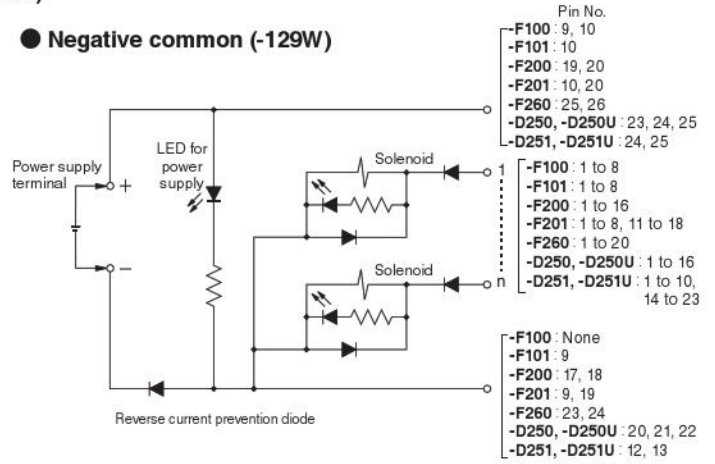

## D-sub connector (For 100VAC and 120VAC specification)

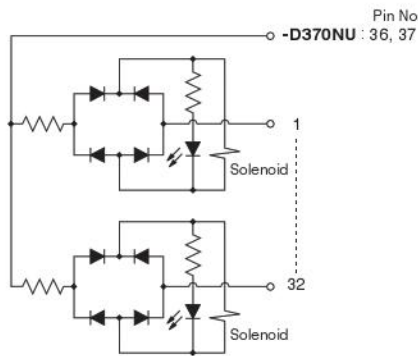
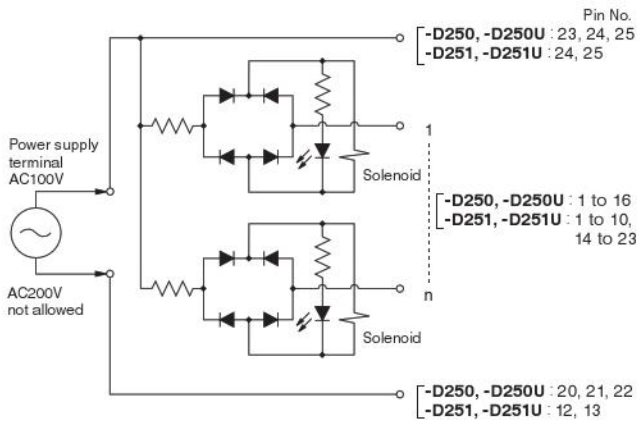

# F18 Series Detailed Diagram of Wiring System

## Terminal block (For 12VDC and 24VDC specifications)

### ● Positive common

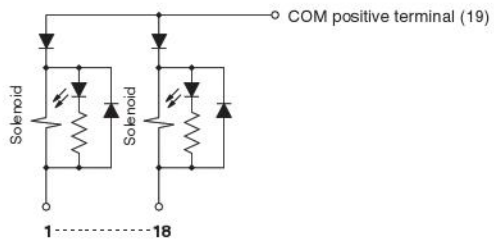

### ● Negative common (-129W)

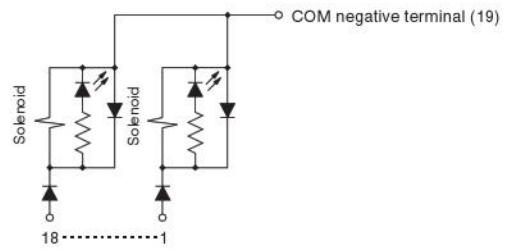

## Terminal block (For 100VAC and 120VAC specification)

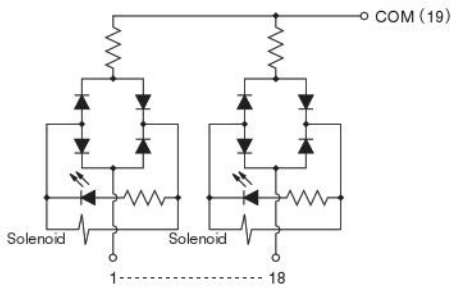

## Pin No. (Terminal No.) and Corresponding Solenoid (For Monoblock Manifold A Type and F Type Wire-Saving Type, Split Manifold Plug-in Type)

The examples below show the relationship between the split manifold pin No. (terminal No.) and the corresponding solenoid. This is the same for monoblock manifold A type wire-saving type, and monoblock manifold F type wire-saving type. All the mounting examples show cases of the maximum number of control pins used.

### Flat cable connector (10-pin)

● In the case of wiring specification **-F100**□□ (Maximum number of control pins: 8)

**Example 1** **F10M5PJ-JR-F100 DC24V** stn.1~2 F10T1-A1 DC24V  
stn.3~4 F10T2-A1 DC24V  
stn.5 F10BPP

Number of units : 5 units  
 Wiring specification : **-F100**  
 Wiring connection specification : **Blank** (packed wiring)

(Top View) Triangle mark

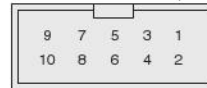

Pin No.	9	7	5	3	1
Valve No.	+	5A	4A	3A	1A
Pin No.	10	8	6	4	2
Valve No.	+	5B	4B	3B	2A

**Example 2** **F10M4PJ-JR-F100-W DC24V** stn.1~2 F10T1-A1 DC24V  
stn.3~4 F10T2-A1 DC24V

Number of units : 4 units  
 Wiring specification : **-F100**  
 Wiring connection specification : **-W** (double wiring)

(Top View) Triangle mark

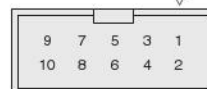

Pin No.	9	7	5	3	1
Valve No.	+	4A	3A	2A	1A
Pin No.	10	8	6	4	2
Valve No.	+	4B	3B	2B	1B

### Flat cable connector (10-pin)

● In the case of wiring specification **-F101**□□ (Maximum number of control pins: 8)

**Example 1** **F10M5PJ-JR-F101 DC24V** stn.1~2 F10T1-A1 DC24V  
stn.3~4 F10T2-A1 DC24V  
stn.5 F10BPP

Number of units : 5 units  
 Wiring specification : **-F101**  
 Wiring connection specification : **Blank** (packed wiring)

(Top View) Triangle mark

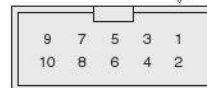

Pin No.	9	7	5	3	1
Valve No.	-	5A	4A	3A	1A
Pin No.	10	8	6	4	2
Valve No.	+	5B	4B	3B	2A

Note: For the no-power terminal type, set pin No.9 to NC (unused pin).

**Example 2** **F10M4PJ-JR-F101-W DC24V** stn.1~2 F10T1-A1 DC24V  
stn.3~4 F10T2-A1 DC24V

Number of units : 4 units  
 Wiring specification : **-F101**  
 Wiring connection specification : **-W** (double wiring)

(Top View) Triangle mark

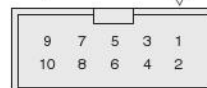

Pin No.	9	7	5	3	1
Valve No.	-	4A	3A	2A	1A
Pin No.	10	8	6	4	2
Valve No.	+	4B	3B	2B	1B

Note: For the no-power terminal type, set pin No.9 to NC (unused pin).

- Notes: 1. The valve No.1A, 1B, 2A, 2B... numerals show the stn. numbers in order, while the letters A and B show the A and B sides of the solenoid.  
 2. The stn. numbers are counted from the left, 1, 2... with the solenoid on top and the valve in front.  
 3. When selecting wiring connection specification **-W**, all wiring becomes double wiring, regardless of valve specifications.  
 4. Caution should be exercised that the block-off plate is always double wiring (allocated 2 control pins to 1 unit), regardless of the wiring connection specifications.  
 5. Connector pin numbers are assigned for the sake of convenience. Use the ▽ mark as the reference.

# Pin No. (Terminal No.) and Corresponding Solenoid (For Monoblock Manifold A Type and F Type Wire-Saving Type, Split Manifold Plug-in Type)

The examples below show the relationship between the split manifold pin No. (terminal No.) and the corresponding solenoid. This is the same for monoblock manifold A type wire-saving type, and monoblock manifold F type wire-saving type. All the mounting examples show cases of the maximum number of control pins used.

## Flat cable connector (20-pin)

● In the case of wiring specification **-F200** (Maximum number of control pins: 16)

### Example 1

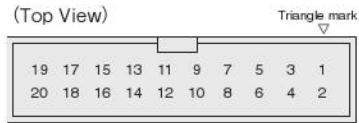
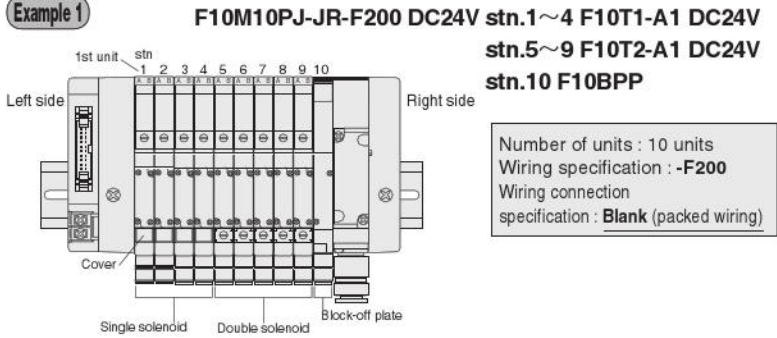

Pin No.	19	17	15	13	11	9	7	5	3	1
Valve No.	+	-	10A	9A	8A	7A	6A	5A	3A	1A
Pin No.	20	18	16	14	12	10	8	6	4	2
Valve No.	+	-	10B	9B	8B	7B	6B	5B	4A	2A

Note: For the no-power terminal type, set pins No.17 and 18 to NC (unused pins).

### Example 2

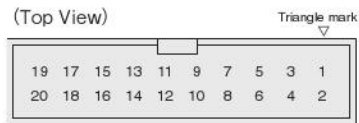
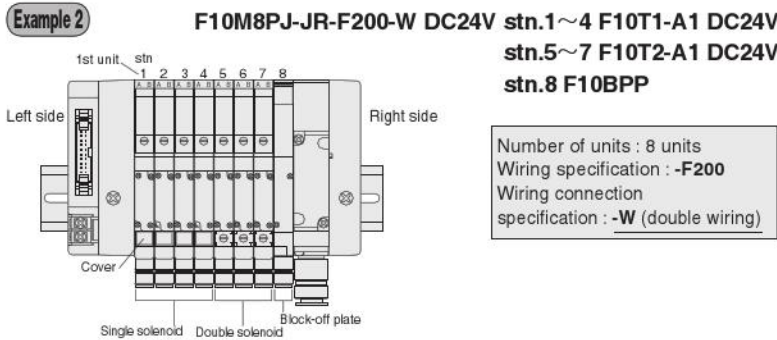

Pin No.	19	17	15	13	11	9	7	5	3	1
Valve No.	+	-	8A	7A	6A	5A	4A	3A	2A	1A
Pin No.	20	18	16	14	12	10	8	6	4	2
Valve No.	+	-	8B	7B	6B	5B	4B	3B	2B	1B

Note: For the no-power terminal type, set pins No.17 and 18 to NC (unused pins).

## Flat cable connector (20-pin)

● In the case of wiring specification **-F201** (Maximum number of control pins: 16)

### Example 1

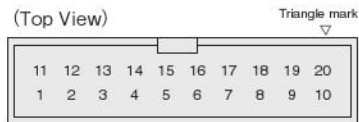
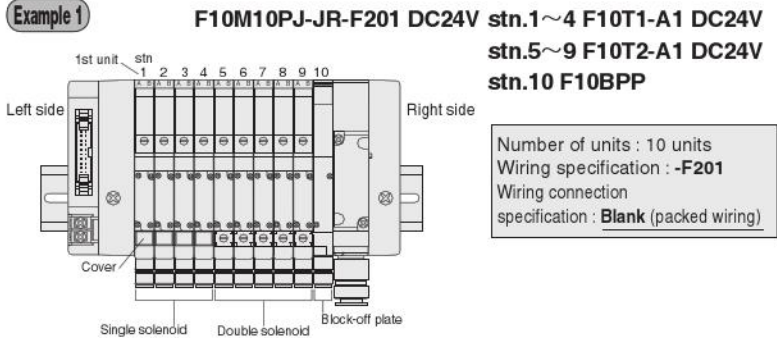

Pin No.	11	12	13	14	15	16	17	18	19	20
Valve No.	7A	7B	8A	8B	9A	9B	10A	10B	-	+
Pin No.	1	2	3	4	5	6	7	8	9	10
Valve No.	1A	2A	3A	4A	5A	5B	6A	6B	-	+

Note: For the no-power terminal type, set pins No.9 and 19 to NC (unused pins).

### Example 2

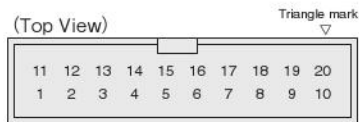
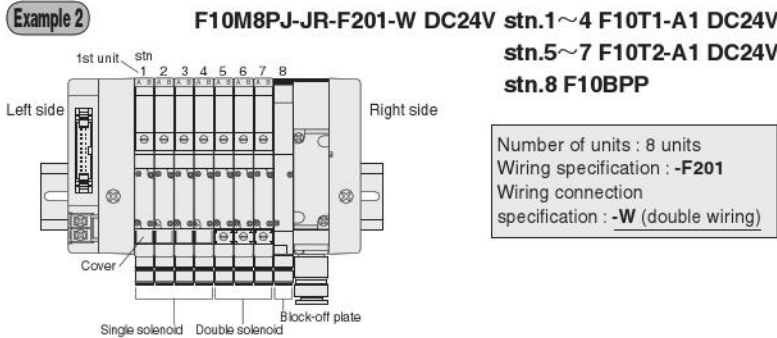

Pin No.	11	12	13	14	15	16	17	18	19	20
Valve No.	5A	5B	6A	6B	7A	7B	8A	8B	-	+
Pin No.	1	2	3	4	5	6	7	8	9	10
Valve No.	1A	1B	2A	2B	3A	3B	4A	4B	-	+

Note: For the no-power terminal type, set pins No.9 and 19 to NC (unused pins).

**Caution:** Connector pin numbers are assigned for the sake of convenience. Use the ▼ mark as the reference.

- Notes: 1. The valve No.1A, 1B, 2A, 2B... numerals show the stn. numbers in order, while the letters A and B show the A and B sides of the solenoid.  
 2. The stn. numbers are counted from the left, 1, 2... with the solenoid on top and the valve in front.  
 3. When selecting wiring connection specification **-W**, all wiring becomes double wiring, regardless of valve specifications.  
 4. Caution should be exercised that the block-off plate is always double wiring (allocated 2 control pins to 1 unit), regardless of the wiring connection specifications.  
 5. Connector pin numbers are assigned for the sake of convenience. Use the ▼ mark as the reference.

The examples below show the relationship between the split manifold pin No. (terminal No.) and the corresponding solenoid. This is the same for monoblock manifold A type wire-saving type, and monoblock manifold F type wire-saving type. All the mounting examples show cases of the maximum number of control pins used.

### Flat cable connector (26-pin)

● In the case of wiring specification **-F260**□□ (Maximum number of control pins: 20)

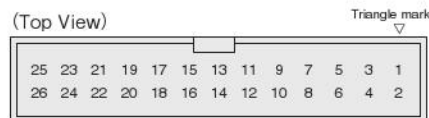
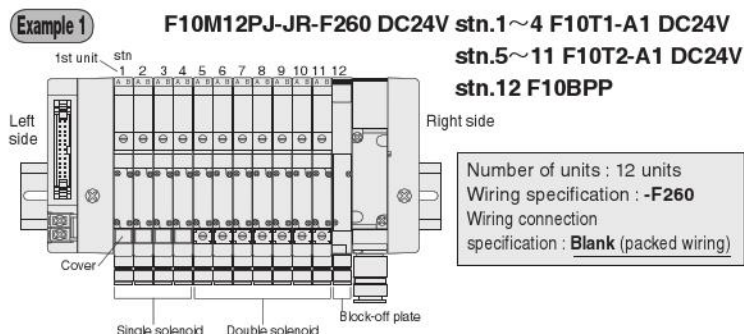

Pin No.	25	23	21	19	17	15	13	11	9	7	5	3	1
Valve No.	+	-		12A	11A	10A	9A	8A	7A	6A	5A	3A	1A
Pin No.	26	24	22	20	18	16	14	12	10	8	6	4	2
Valve No.	+	-		12B	11B	10B	9B	8B	7B	6B	5B	4A	2A

Note: For the no-power terminal type, set pins No.23 and 24 to NC (unused pins).

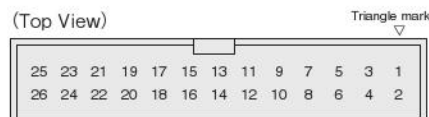
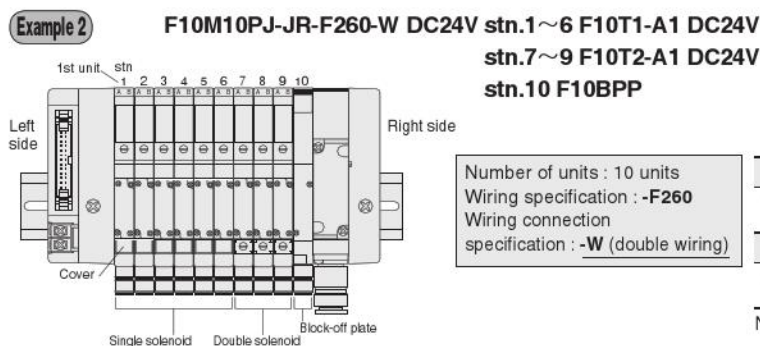

Pin No.	25	23	21	19	17	15	13	11	9	7	5	3	1
Valve No.	+	-		10A	9A	8A	7A	6A	5A	4A	3A	2A	1A
Pin No.	26	24	22	20	18	16	14	12	10	8	6	4	2
Valve No.	+	-		10B	9B	8B	7B	6B	5B	4B	3B	2B	1B

Note: For the no-power terminal type, set pins No.23 and 24 to NC (unused pins).

- Notes:
1. The valve No.1A, 1B, 2A, 2B... numerals show the stn. numbers in order, while the letters A and B show the A and B sides of the solenoid.
  2. The stn. numbers are counted from the left, 1, 2... with the solenoid on top and the valve in front.
  3. When selecting wiring connection specification **-W**, all wiring becomes double wiring, regardless of valve specifications.
  4. Caution should be exercised that the block-off plate is always double wiring (allocated 2 control pins to 1 unit), regardless of the wiring connection specifications.
  5. Connector pin numbers are assigned for the sake of convenience. Use the ▽ mark as the reference.

# Pin No. (Terminal No.) and Corresponding Solenoid (For Monoblock Manifold A Type and F Type Wire-Saving Type, Split Manifold Plug-in Type)

The examples below show the relationship between the split manifold pin No. (terminal No.) and the corresponding solenoid. This is the same for monoblock manifold A type wire-saving type, and monoblock manifold F type wire-saving type. All the mounting examples show cases of the maximum number of control pins used.

## D-sub connector (25-pin)

● In the case of wiring specification **-D250** (Maximum number of control pins: 16)

**Example 1** F10M10PJ-JR-D250 DC24V stn.1~4 F10T1-A1 DC24V  
stn.5~9 F10T2-A1 DC24V  
stn.10 F10BPP

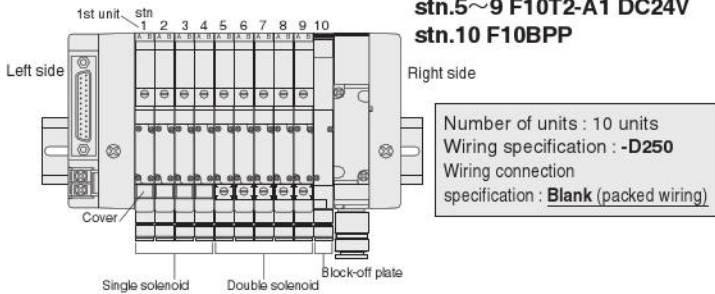

**Caution:** The connector pin numbers are assigned based on the solenoid valve wiring sequence for the sake of convenience. They differ from the pin locations and pin numbers (marking) prescribed (JIS-X5101) for the Data Circuit-terminating Equipment (DCE).

(Top View)



Pin No.	1	3	5	7	9	11	13	15	17	19	21	23	25
Valve No.	1A	3A	5A	6A	7A	8A	9A	10A			-	+	+
Pin No.	2	4	6	8	10	12	14	16	18	20	22	24	
Valve No.	2A	4A	5B	6B	7B	8B	9B	10B			-	-	+

Note: For the no-power terminal type, set pins No.20, 21, and 22 to NC (unused pins).

**Example 2** F10M8PJ-JR-D250-W DC24V stn.1~4 F10T1-A1 DC24V  
stn.5~7 F10T2-A1 DC24V  
stn.8 F10BPP

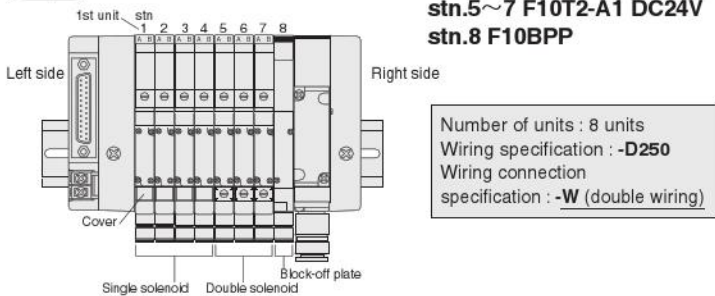

(Top View)



Pin No.	1	3	5	7	9	11	13	15	17	19	21	23	25
Valve No.	1A	2A	3A	4A	5A	6A	7A	8A			-	+	+
Pin No.	2	4	6	8	10	12	14	16	18	20	22	24	
Valve No.	1B	2B	3B	4B	5B	6B	7B	8B			-	-	+

Note: For the no-power terminal type, set pins No.20, 21, and 22 to NC (unused pins).

## D-sub connector (25-pin)

● In the case of wiring specification **-D251** Pin locations based on JIS (Maximum number of control pins: 20)

**Example 1** F10M12PJ-JR-D251 DC24V stn.1~4 F10T1-A1 DC24V  
stn.5~11 F10T2-A1 DC24V  
stn.12 F10BPP

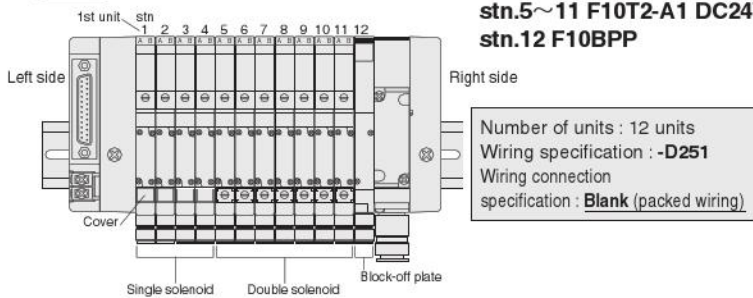

(Top View)



Pin No.	1	2	3	4	5	6	7	8	9	10	11	12	13
Valve No.	1A	2A	3A	4A	5A	5B	6A	6B	7A	7B		-	-
Pin No.	14	15	16	17	18	19	20	21	22	23	24	25	
Valve No.	8A	8B	9A	9B	10A	10B	11A	11B	12A	12B	+	+	

Note: For the no-power terminal type, set pins No.12 and 13 to NC (unused pins).

**Example 2** F10M10PJ-JR-D251-W DC24V stn.1~6 F10T1-A1 DC24V  
stn.7~9 F10T2-A1 DC24V  
stn.10 F10BPP

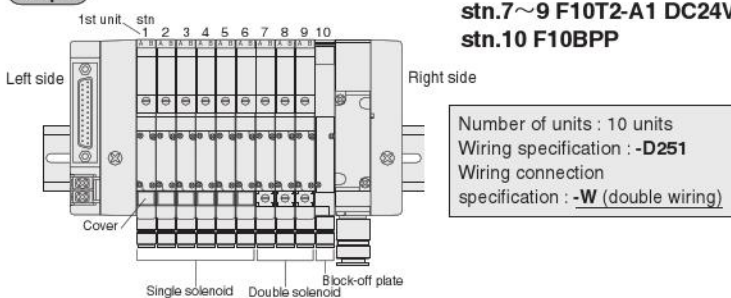

(Top View)



Pin No.	1	2	3	4	5	6	7	8	9	10	11	12	13
Valve No.	1A	1B	2A	2B	3A	3B	4A	4B	5A	5B		-	-
Pin No.	14	15	16	17	18	19	20	21	22	23	24	25	
Valve No.	6A	6B	7A	7B	8A	8B	9A	9B	10A	10B	+	+	

Note: For the no-power terminal type, set pins No.12 and 13 to NC (unused pins).

Notes: 1. The valve No.1A, 1B, 2A, 2B... numerals show the stn. numbers in order, while the letters A and B show the A and B sides of the solenoid.

2. The stn. numbers are counted from the left, 1, 2... with the solenoid on top and the valve in front.

3. When selecting wiring connection specification **-W**, all wiring becomes double wiring, regardless of valve specifications.

4. Caution should be exercised that the block-off plate is always double wiring (allocated 2 control pins to 1 unit), regardless of the wiring connection specifications.

## Pin No. (Terminal No.) and Corresponding Solenoid (For Split Manifold Plug-in Type)

The examples below show the relationship between the split manifold pin numbers and the corresponding solenoids. All the mounting examples show cases of the maximum number of control pins used.

### D-sub connector (37-pin)

- In the case of wiring specification **-D370NU**  
(Maximum number of control pins: 32)

#### Example 1

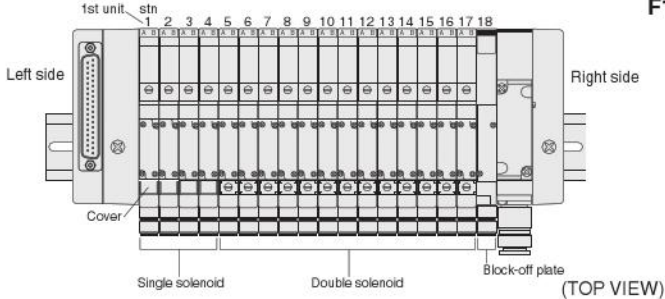

(TOP VIEW)

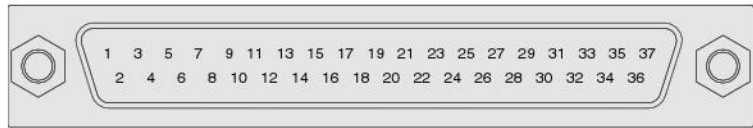

Pin No.	1	3	5	7	9	11	13	15	17	19	21	23	25	27	29	31	33	35	37
Valve No.	1A	3A	5A	6A	7A	8A	9A	10A	11A	12A	13A	14A	15A	16A	17A	18A			+
Pin No.	2	4	6	8	10	12	14	16	18	20	22	24	26	28	30	32	34	36	
Valve No.	2A	4A	5B	6B	7B	8B	9B	10B	11B	12B	13B	14B	15B	16B	17B	18B			+

**Caution:** For the sake of convenience, the connector pins are assigned based on the solenoid valve wiring sequence, which differs from the pin locations and pin numbers (marking) prescribed in JIS-X5103 for the Data Circuit-terminating Equipment (DCE).

**F10M18PJ-JR-D370NU DC24V** stn.1~4 **F10T1-A1 DC24V**  
stn.5~17 **F10T2-A1 DC24V**  
stn.18 **F10BPP**

Number of units : 18 units  
Wiring specification : **-D370NU**  
Wiring connection specification :  
**Blank** (packed wiring)

#### Example 2

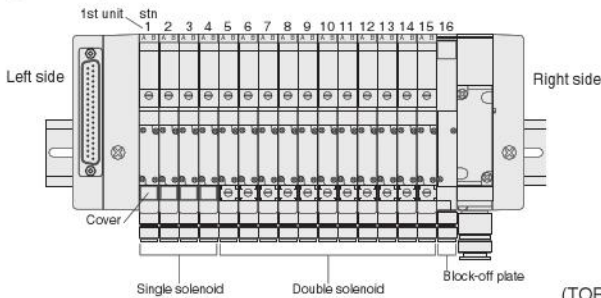

(TOP VIEW)

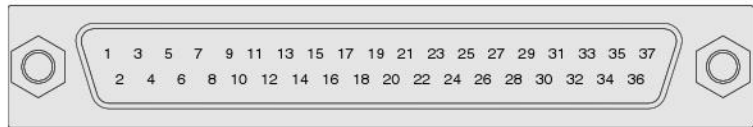

Pin No.	1	3	5	7	9	11	13	15	17	19	21	23	25	27	29	31	33	35	37
Valve No.	1A	2A	3A	4A	5A	6A	7A	8A	9A	10A	11A	12A	13A	14A	15A	16A			+
Pin No.	2	4	6	8	10	12	14	16	18	20	22	24	26	28	30	32	34	36	
Valve No.	1B	2B	3B	4B	5B	6B	7B	8B	9B	10B	11B	12B	13B	14B	15B	16B			+

**F10M16PJ-JR-D370NU-W DC24V** stn.1~4 **F10T1-A1 DC24V**  
stn.5~15 **F10T2-A1 DC24V**  
stn.16 **F10BPP**

Number of units : 16 units  
Wiring specification : **-D370NU**  
Wiring connection specification :  
**-W** (double wiring)

- Notes: 1. The valve No.1A, 1B, 2A, 2B... numerals show the stn. numbers in order, while the letters A and B show the A and B sides of the solenoid.  
2. The stn. numbers are counted from the left, 1, 2... with the solenoid on top and the valve in front.  
3. When selecting wiring connection specification **-W**, all wiring becomes double wiring, regardless of valve specifications.  
4. Caution should be exercised that the block-off plate is always double wiring (allocated 2 control pins to 1 unit), regardless of the wiring connection specifications.

## Pin No. (Terminal No.) and Corresponding Solenoid (For Split Manifold Plug-in Type)

The examples below show the relationship between the split manifold terminal No. and the corresponding solenoid.  
All the mounting examples show cases of the maximum number of control pins used.

### Terminal block type (19 terminals, M3 screws)

● In the case of wiring specification -T200 (Maximum number of control pins: 18)

#### Example 1

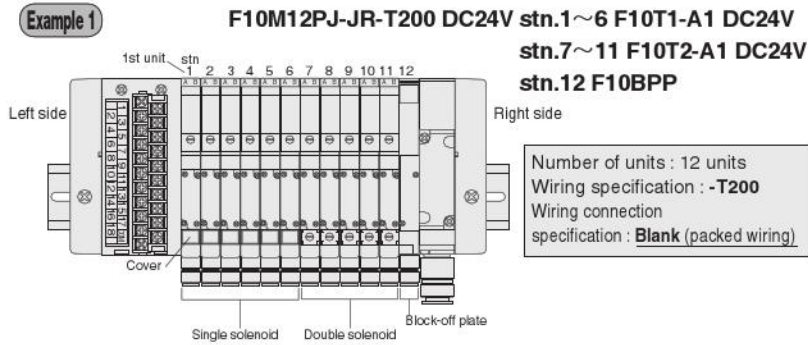

(Top View)

1	3	5	7	9	11	13	15	17	COM
2	4	6	8	10	12	14	16	18	

Terminal No.	1	3	5	7	9	11	13	15	17	COM
Valve No.	1A	3A	5A	7A	8A	9A	10A	11A	12A	+
Terminal No.	2	4	6	8	10	12	14	16	18	
Valve No.	2A	4A	6A	7B	8B	9B	10B	11B	12B	

#### Example 2

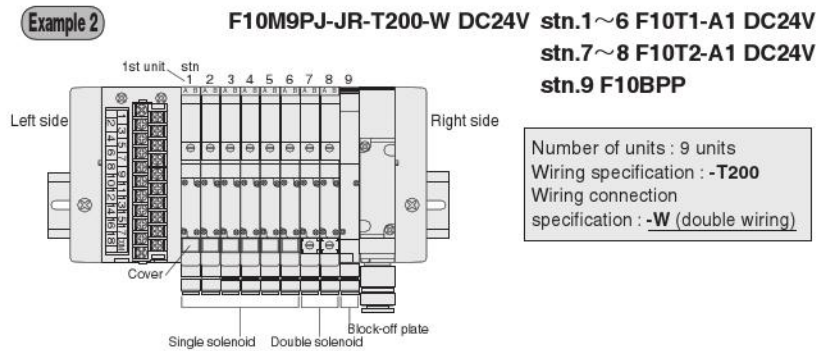

(Top View)

1	3	5	7	9	11	13	15	17	COM
2	4	6	8	10	12	14	16	18	

Terminal No.	1	3	5	7	9	11	13	15	17	COM
Valve No.	1A	2A	3A	4A	5A	6A	7A	8A	9A	+
Terminal No.	2	4	6	8	10	12	14	16	18	
Valve No.	1B	2B	3B	4B	5B	6B	7B	8B	9B	

- Notes: 1. The valve No.1A, 1B, 2A, 2B... numerals show the stn. numbers in order, while the letters A and B show the A and B sides of the solenoid.  
2. The stn. numbers are counted from the left, 1, 2... with the solenoid on top and the valve in front.  
3. When selecting wiring connection specification **-W**, all wiring becomes double wiring, regardless of valve specifications.  
4. Caution should be exercised that the block-off plate is always double wiring (allocated 2 control terminals to 1 unit), regardless of the wiring connection specifications.

# F Series Cable Assembly by Wiring Specification

A dedicated cable assembly is provided for each wiring specification.

## Order codes

FMA -  -  -

Types of dedicated cables

- 100W : -F100□□ dedicated cable assembly
- 101W : -F101□□ dedicated cable assembly
- 200W : -F200□□ dedicated cable assembly
- 201W : -F201□□ dedicated cable assembly
- 260W : -F260□□ dedicated cable assembly
- 250W : -D250□□ dedicated cable assembly
- 251W : -D251□□ dedicated cable assembly

Cable length: 0.5 - 20 m [1.6-65.6 ft.] (enter at 0.5 m pitch)  
 ※Cable used UL STYLE NO.20266 150V 80°C [176°F]  
 AWG28 (7/0.127 [strands/mm])

**Blank:** Loose wire [with dedicated label/No.]  
**Y:** Y terminal (M3.5) [with marker tube/No.]

Note: Perform wiring operations correctly, while checking each pin location, connector No., label No., and marker tube No., etc.

### ●-F100□□ dedicated cable assembly

FMA-100W-  -

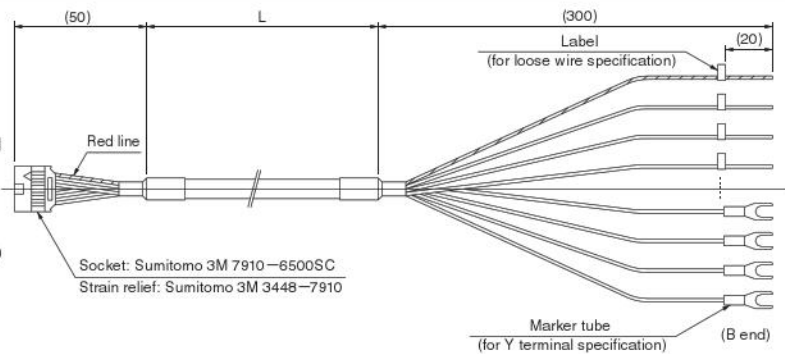
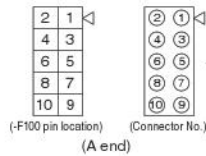

A end	-F100 pin location	1	2	3	4	5	6	7	8	9	10
	Connector No.	①	②	③	④	⑤	⑥	⑦	⑧	⑨	⑩
B end	Label, marker tube No.	1	2	3	4	5	6	7	8	COM	COM

### ●-F101□□ dedicated cable assembly

FMA-101W-  -

Note: When wiring specification is the -F101□N (no power terminal) type, the -F101 pin location No.9 on the manifold side is set to NC (unused pin).

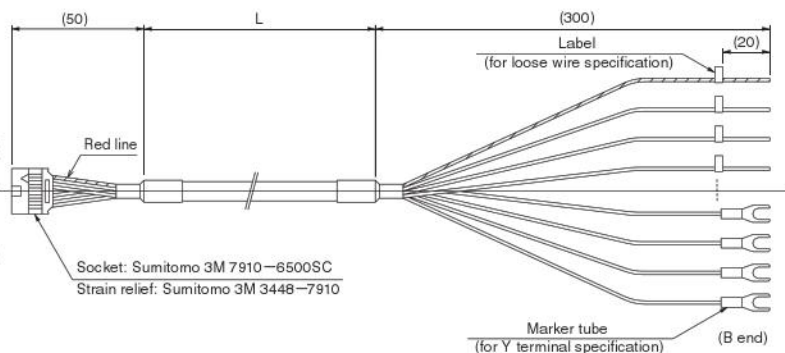
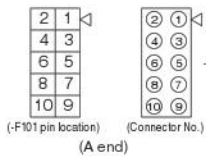

A end	-F101 pin location	1	2	3	4	5	6	7	8	9	10
	Connector No.	①	②	③	④	⑤	⑥	⑦	⑧	⑨	⑩
B end	Label, marker tube No.	1	2	3	4	5	6	7	8	-	+

### ●-F200□□ dedicated cable assembly

FMA-200W-  -

Note: When wiring specification is the -F200□N (no power terminal) type, the -F200 pin location No.17 and 18 on the manifold side are set to NC (unused pins).

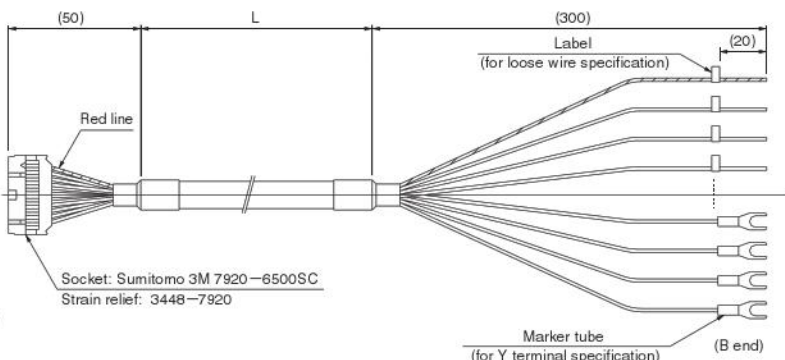
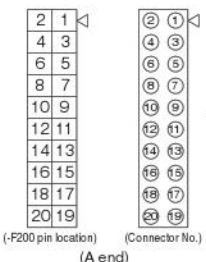

A end	-F200 pin location	1	2	3	4	5	6	7	8	9	10	11	12	13	14	15	16	17	18	19	20
	Connector No.	①	②	③	④	⑤	⑥	⑦	⑧	⑨	⑩	⑪	⑫	⑬	⑭	⑮	⑯	⑰	⑱	⑲	⑲
B end	Label, marker tube No.	1	2	3	4	5	6	7	8	9	10	11	12	13	14	15	16	-	-	+	+

# F Series Cable Assembly by Wiring Specification

## ●-F201□□ dedicated cable assembly

FMA-201W-□ - □

- Notes: 1. Be aware the pin location No. and connector No. are not the same.  
 2. When wiring specification is the -F201□N (no power terminal) type, the -F201 pin location No.9 and 19 on the manifold side are set to NC (unused pins).

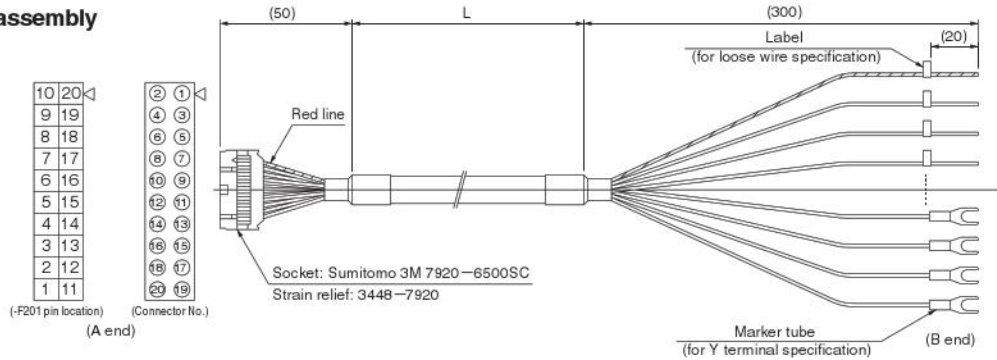

A end	-F201 pin location	1	2	3	4	5	6	7	8	9	10	11	12	13	14	15	16	17	18	19	20
	Connector No.	20	18	16	14	12	10	8	6	4	2	19	17	15	13	11	9	7	5	3	1
B end	Label, marker tube No.	1	2	3	4	5	6	7	8	-	+	9	10	11	12	13	14	15	16	-	+

## ●-F260□□ dedicated cable assembly

FMA-260W-□ - □

- Note: When wiring specification is the -F260□N (no power terminal) type, the -F260 pin location No.23 and 24 on the manifold side are set to NC (unused pins).

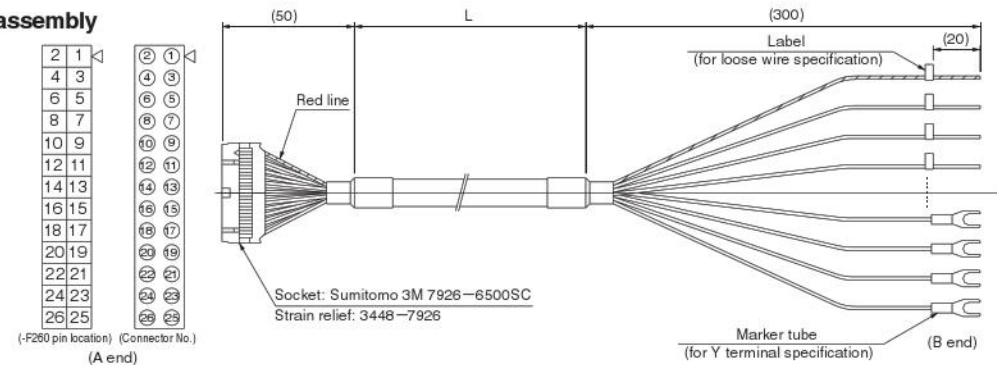

A end	-F260 pin location	1	2	3	4	5	6	7	8	9	10	11	12	13	14	15	16	17	18	19	20	21	22	23	24	25	26
	Connector No.	1	2	3	4	5	6	7	8	9	10	11	12	13	14	15	16	17	18	19	20	21	22	23	24	25	26
B end	Label, marker tube No.	1	2	3	4	5	6	7	8	9	10	11	12	13	14	15	16	17	18	19	20	/	/	-	-	+	+

## ●-D250□□ dedicated cable assembly

FMA-250W-□ - □

- Notes: 1. Be aware the pin location No. and connector No. are not the same.  
 2. When wiring specification is the -D250□N (no power terminal) type, the -D250 pin location No.20, 21 and 22 on the manifold side are set to NC (unused pins).

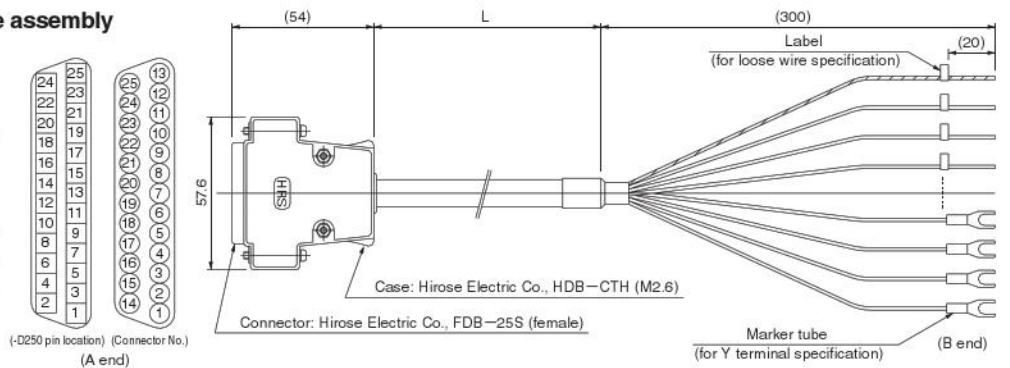

A end	-D250 pin location	1	2	3	4	5	6	7	8	9	10	11	12	13	14	15	16	17	18	19	20	21	22	23	24	25
	Connector No.	1	14	2	15	3	16	4	17	5	18	6	19	7	20	8	21	9	22	10	23	11	24	12	25	13
B end	Label, marker tube No.	1	2	3	4	5	6	7	8	9	10	11	12	13	14	15	16	/	/	/	-	-	-	+	+	+

## ●-D251□□ dedicated cable assembly

FMA-251W-□ - □

- Note: When wiring specification is the -D251□N (no power terminal) type, the -D251 pin location No.12 and 13 on the manifold side are set to NC (unused pins).

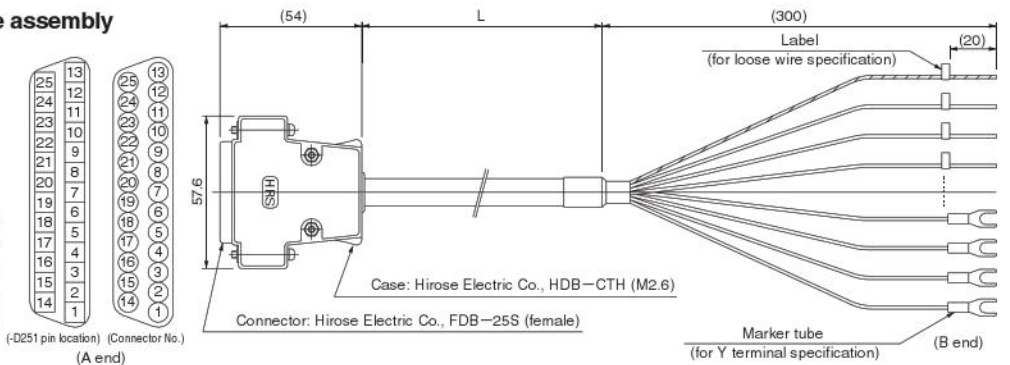

A end	-D251 pin location	1	2	3	4	5	6	7	8	9	10	11	12	13	14	15	16	17	18	19	20	21	22	23	24	25	
	Connector No.	1	2	3	4	5	6	7	8	9	10	11	12	13	14	15	16	17	18	19	20	21	22	23	24	25	
B end	Label, marker tube No.	1	2	3	4	5	6	7	8	9	10	/	/	-	-	11	12	13	14	15	16	17	18	19	20	+	+

# SOLENOID VALVES

## F10 SERIES

### Contents

Specifications	106
Dimensions of Single Valve Unit	111
Dimensions of Monoblock Manifold	114
Dimensions of Monoblock Manifold, Wire-saving Type	117
Dimensions of PC Board Manifold	119
Dimensions of Split Manifold Non-plug-in Type	120
Dimensions of Split Manifold Plug-in Type	122
Dimensions of Serial Transmission Compatible Manifold	131

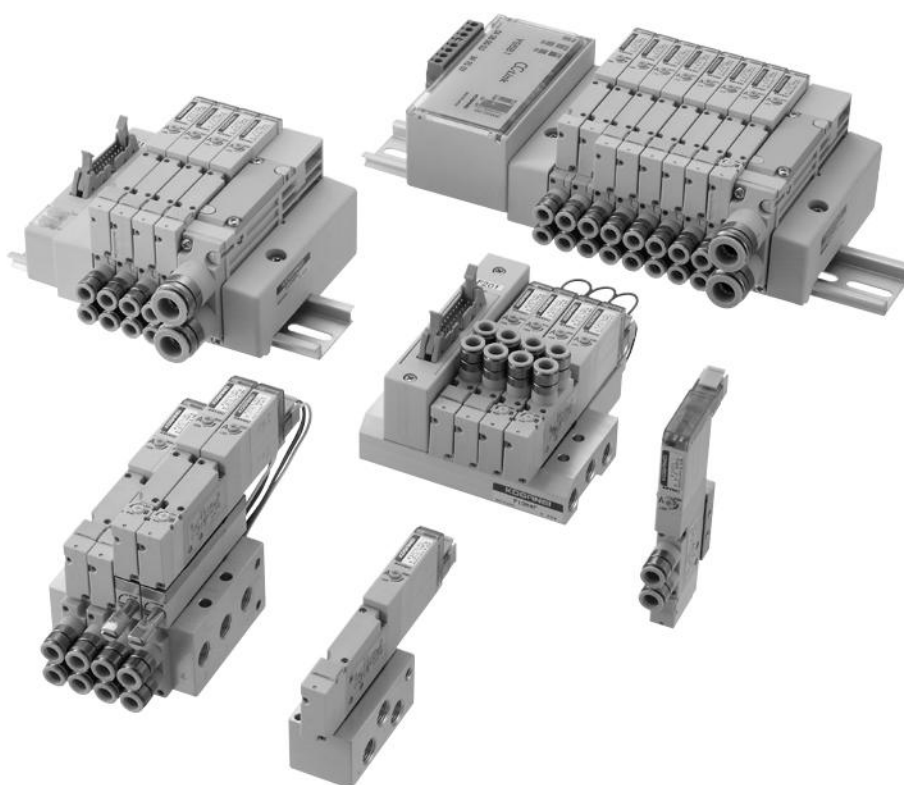

# F10 SERIES Specifications

## Specifications

### Basic Models and Valve Functions

Item	Basic model	F10□T0	F10□T1 F10□T2	F10□T3 F10□T4 F10□T5	F10□TA F10□TB F10□TC
	Number of positions	2 positions		3 positions	
Number of ports	5				Tandem 3-port
Valve function	Single solenoid only	Both single and double solenoid use		Closed center, Exhaust center, Pressure center	NC/NC, NO/NO, NC/NO

Remark: For the optional specifications and order codes, see p.44-71.

### Specifications

Item	Basic model	F10□T0 F10□T1 F10□T2	F10□T3 F10□T4 F10□T5	F10□TA F10□TB F10□TC	F10□T0G F10□T1G F10□T2G	F10□T3G F10□T4G F10□T5G	F10□T0V F10□T1V F10□T2V	F10□T3V
	Media	Air						
Operation type	Internal pilot type				External pilot type (for positive pressure)		External pilot type (for vacuum)	
Flow rate characteristics	Sonic conductance C dm <sup>3</sup> /(s·bar) <sup>Note1</sup>	0.97	0.93	0.75	0.97	0.93	0.97	0.93
	Effective area <sup>Note2</sup> mm <sup>2</sup> [Cv]	4.8 [0.27]	4.6 [0.25]	3.7 [0.21]	4.8 [0.27]	4.6 [0.25]	4.8 [0.27]	4.6 [0.25]
Port size <sup>Note3</sup>	M5×0.8, 10-32UNF, dual use fitting for φ4 and φ6, Rc1/8, NPT1/8							
Lubrication	Not required							
Operating pressure range	Main valve	0.2~0.7 MPa [29~102 psi.]			0~0.7 MPa [0~102 psi.] <sup>Note4</sup>		-100 kPa~0.15 MPa [-29.53 in.Hg~22 psi.]	
	External pilot	—			0.2~0.7 MPa [29~102 psi.] <sup>Note4</sup>		0.2~0.7 MPa [29~102 psi.]	
Proof pressure	MPa [psi.] 1.05 [152]							
Response time <sup>Note5</sup> ms	12VDC, 24VDC	15/15(20) or below	15/20 (25) or below	15/20 (25) or below	15/15 (20) or below	15/20 (25) or below	15/15 (20) or below	15/20 (25) or below
	100VAC	15/15 or below	15/20 or below	—	15/15 or below	15/20 or below	15/15 or below	15/20 or below
Maximum operating frequency	Hz 5							
Minimum time to energize for self holding <sup>Note6</sup> ms	50		—		50		50	
Operating temperature range (atmosphere and media) °C [°F]	5~50 [41~122]							
Shock resistance	m/s <sup>2</sup> [G] 294.2 [30]							
Mounting direction	Any							

Notes: 1. For details, see the flow rate characteristics on p.108.

2. The effective area is a calculated value, and not a measured value.

3. For details, see the port size on p.107.

4. When the main valve pressure is 0.2~0.7 MPa [29~102 psi.], set the external pilot pressure to the main valve pressure or higher, and 0.7 MPa [102 psi.] or less.

Remark: Specification values are based on Koganei test standards.

Notes: 5. Values when air pressure is 0.5 MPa [73 psi.]. For switching phase timing in the AC specification, add a maximum of 5 ms to the response time. The values for 2-position valves are those when used as a single solenoid, and the values for 3-position valves are those when switching from the neutral position of closed center. Values in parentheses ( ) are for low-current type.

6. When used as a double solenoid valve. Excludes T0.

### Solenoid Specifications

Item	Rated voltage	12VDC	24VDC (Standard type)	24VDC (Low-current type)	100VAC	120VAC	
	Voltage range	V	10.8~13.2 (12±10%)	21.6~26.4 (24±10%)	21.6~26.4 (24±10%)	90~110 (100±10%)	108~132 (120±10%)
Rated frequency	Hz	—	—	—	50   60	50   60	
Standard	Current (when rated voltage is applied) mA (r.m.s)	33	17	—	8	8.3	
	Power consumption W	0.4	0.4	—	0.8 VA	1 VA	
Low-current type	Current (when rated voltage is applied)	Starting mA	—	17	—	—	
		Holding mA	—	4.2			
	Power consumption	Starting W	—	—	0.4	—	—
		Holding W	—	—	0.1		
Starting time (standard)	ms	—	—	70	—	—	
Allowable leakage current	mA	2.0	1.0	1.0	1.0	1.0	
Type of insulation	Type B						
Insulation resistance <sup>Note1</sup>	MΩ	Over 100					
Color of LED indicator <sup>Note2</sup>	14(SA) : Red, 12(SB) : Green						
Surge suppression (as standard)	Surge absorption transistor		Flywheel diode		Bridge diode		

Notes: 1. Value at 500VDC megger.

2. The color of the T0 indicator is red only.

Remark: Specification values are based on Koganei test standards.

## Cylinder Operating Speed

## Flow Rate

### How to obtain cylinder speed

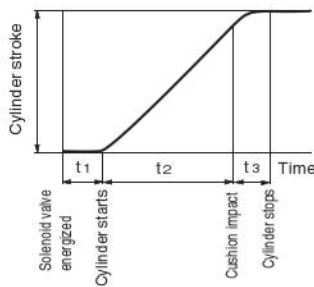

### Measuring conditions

- Air pressure : 0.5 MPa [73 psi.]
- Piping (outer diameter × inner diameter × length) :  $\phi 6 \times \phi 4 \times 1000$  mm [39 in.]
- Fitting : Quick fitting TS6-01
- Load ratio =  $\frac{\text{Load}}{\text{Cylinder theoretical thrust}}$  (%)
- Cylinder stroke : 150 mm [5.91 in.]

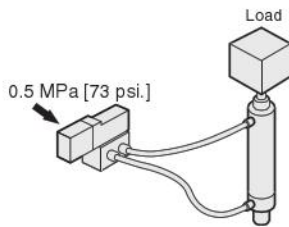

### Maximum operating speed

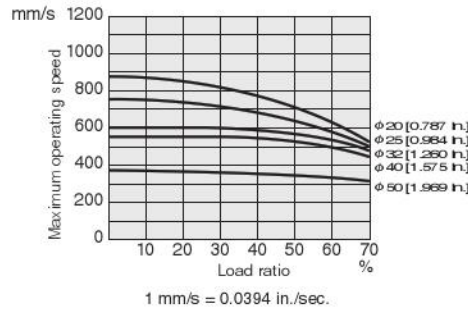

### Delay time

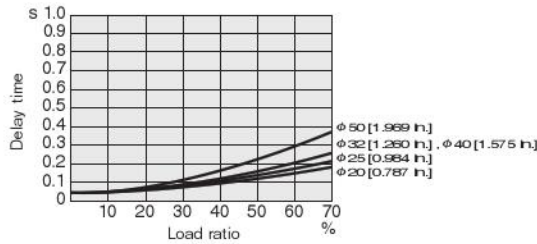

Note: Delay time may vary according to the cylinder stroke.

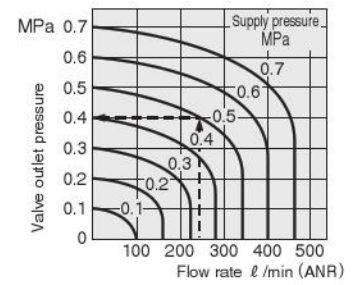

1 MPa = 145 psi., 1 l/min = 0.0353 ft.<sup>3</sup>/min.

### How to read the graph

When the supply pressure is 0.5 MPa [73 psi.] and flow rate is 240 l/min [8.47 ft.<sup>3</sup>/min.] (ANR), the valve outlet pressure becomes 0.4 MPa [58 psi.].

## Port Size

Description/Piping specification		PR	X (P2)	4 (A), 2 (B)	1 (P), 3 (R2), 5 (R1), 3, 5 (R)
With sub-base		M5 × 0.8, 10-32UNF	M5 × 0.8, 10-32UNF	Rc1/8, NPT1/8	Rc1/8, NPT1/8
Single unit	With female thread block	—	—	M5 × 0.8, 10-32UNF	M5 × 0.8, 10-32UNF
	With dual use fitting block	—	—	Dual use fitting for $\phi 4$ and $\phi 6$	M5 × 0.8, 10-32UNF
	With single use fitting block	—	—	$\phi 4$ or $\phi 6$	M5 × 0.8, 10-32UNF
Manifold	Monoblock type with female thread block, and PC board type with female thread block	M5 × 0.8, 10-32UNF	M5 × 0.8, 10-32UNF	M5 × 0.8, 10-32UNF	Rc1/8, NPT1/8
	Monoblock type with fitting block, and PC board type with fitting block	M5 × 0.8, 10-32UNF	M5 × 0.8, 10-32UNF	Dual use fitting for $\phi 4$ and $\phi 6$	Rc1/8, NPT1/8
	Monoblock type with single use fitting block, and PC board type with single use fitting block	M5 × 0.8, 10-32UNF	M5 × 0.8, 10-32UNF	$\phi 4$ or $\phi 6$	Rc1/8, NPT1/8
	Split type with female thread block, and serial transmission type with female thread block	—	M5 × 0.8, 10-32UNF	M5 × 0.8, 10-32UNF	Rc1/4, NPT1/4
	Split type with fitting block, and serial transmission type with fitting block	—	M5 × 0.8, 10-32UNF	Dual use fitting for $\phi 4$ and $\phi 6$	Dual use fitting for $\phi 8$ and $\phi 10$
	Split type with single use fitting block, and serial transmission type with single use fitting block	—	M5 × 0.8, 10-32UNF	$\phi 4$ or $\phi 6$	Single use fitting for $\phi 8$ or $\phi 10$

# Flow Rate Characteristics

## ● When used as a single unit

Basic model	1 (P) → 2 (B) / 1 (P) → 4 (A)		2 (B) → 3 (R2) / 4 (A) → 5 (R1)	
	Sonic conductance C dm <sup>3</sup> /(s·bar)	Critical pressure ratio b	Sonic conductance C dm <sup>3</sup> /(s·bar)	Critical pressure ratio b
F10□T0-A2 F10□T1-A2 F10□T2-A2	0.85	0.14	0.85	0.26
F10□T3-A2 F10□T4-A2 F10□T5-A2	0.82	0.13	0.82	0.29
F10□TA-A2 F10□TB-A2 F10□TC-A2	0.68	0.30	0.69	0.30
F10□T0-F3 F10□T1-F3 F10□T2-F3	0.73	0.29	0.58	0.47
F10□T3-F3 F10□T4-F3 F10□T5-F3	0.69	0.26	0.57	0.46
F10□TA-F3 F10□TB-F3 F10□TC-F3	0.61	0.28	0.54	0.44
F10□T0-F4 F10□T1-F4 F10□T2-F4	0.54	0.39	0.53	0.37
F10□T3-F4 F10□T4-F4 F10□T5-F4	0.53	0.43	0.51	0.34
F10□TA-F4 F10□TB-F4 F10□TC-F4	0.50	0.32	0.50	0.30

Basic model	1 (P) → 2 (B) / 1 (P) → 4 (A)		2 (B) → 3 (R2) / 4 (A) → 5 (R1)	
	Sonic conductance C dm <sup>3</sup> /(s·bar)	Critical pressure ratio b	Sonic conductance C dm <sup>3</sup> /(s·bar)	Critical pressure ratio b
F10□T0-F5 F10□T1-F5 F10□T2-F5	0.57	0.39	0.54	0.38
F10□T3-F5 F10□T4-F5 F10□T5-F5	0.57	0.41	0.54	0.40
F10□TA-F5 F10□TB-F5 F10□TC-F5	0.53	0.33	0.51	0.31
F10□T0-F6 F10□T1-F6 F10□T2-F6	0.64	0.47	0.56	0.42
F10□T3-F6 F10□T4-F6 F10□T5-F6	0.61	0.42	0.56	0.40
F10□TA-F6 F10□TB-F6 F10□TC-F6	0.57	0.34	0.52	0.40

Note: For -F4, value assumes TS6-M5M is mounted on the piping port.

## ● When mounted on a manifold

Manifold model		F10M□F (FP)		F10M□A (AP)		F10M□N (P) (S)	
		1 (P) → 2 (B) / 1 (P) → 4 (A)	2 (B) → 3 (R2) / 4 (A) → 5 (R1)	1 (P) → 2 (B) / 1 (P) → 4 (A)	2 (B) → 3 (R2) / 4 (A) → 5 (R1)	1 (P) → 2 (B) / 1 (P) → 4 (A)	2 (B) → 3 (R2) / 4 (A) → 5 (R1)
Valve model		Sonic conductance C dm <sup>3</sup> /(s·bar)		Sonic conductance C dm <sup>3</sup> /(s·bar)		Sonic conductance C dm <sup>3</sup> /(s·bar)	
F10□T0□ F10□T1□ F10□T2□	Outlet port dual use fitting for φ4 and φ6 ※These are the cases of φ6.	0.84	0.82	0.75	0.76	0.97	0.93
F10□T3□ F10□T4□ F10□T5□		0.83	0.78	0.73	0.72	0.93	0.89
F10□TA□ F10□TB□ F10□TC□		0.70	0.70	0.64	0.66	0.75	0.73
F10□T0□ F10□T1□ F10□T2□	Outlet port φ4 fitting	0.66	0.72	0.63	0.69	0.72	0.79
F10□T3□ F10□T4□ F10□T5□		0.65	0.70	0.62	0.67	0.70	0.77
F10□TA□ F10□TB□ F10□TC□		0.60	0.64	0.56	0.62	0.63	0.67
F10□T0□ F10□T1□ F10□T2□	Outlet port φ6 fitting	0.72	0.81	0.67	0.73	0.80	0.83
F10□T3□ F10□T4□ F10□T5□		0.71	0.73	0.66	0.69	0.78	0.80
F10□TA□ F10□TB□ F10□TC□		0.64	0.66	0.58	0.63	0.68	0.69

Notes: 1. When the individual air supply spacer or the individual air exhaust spacer, the back pressure prevention valve, or the stop valve is used, sonic conductance decreases by about 30%.  
2. For the flow rate characteristics of other outlet ports, consult us.

Remark: Specification values are based on Koganei test standards.

# Mass

## Single Valve Unit Mass

g [oz.]

F10□T□□	F10□T□□-A1	F10□T□□-A2	F10□T□□-FJ	F10□T□□-FJ5	F10□T□□-FJ6
Outlet portion None	Outlet portion With plate	Outlet portion With plate	Outlet portion With dual use fitting block	Outlet portion With φ 4 fitting block	Outlet portion With φ 6 fitting block
Inlet portion None	Inlet portion None	Inlet portion With A type sub-base	Inlet portion None	Inlet portion None	Inlet portion None
44 [1.55]	47 [1.66]	116 [4.09]	55 [1.94]	57 [2.01]	60 [2.12]

g [oz.]

F10□T□□-FM	F10□T□□-F3	F10□T□□-F4	F10□T□□-F5	F10□T□□-F6
Outlet portion With female thread block	Outlet portion With dual use fitting block	Outlet portion With female thread block	Outlet portion With φ 4 fitting block	Outlet portion With φ 6 fitting block
Inlet portion None	Inlet portion With female thread block	Inlet portion With female thread block	Inlet portion With female thread block	Inlet portion With female thread block
51 [1.80]	62 [2.19]	58 [2.05]	64 [2.26]	67 [2.36]

Basic Type F10□T0 is 10 g [0.35 oz.] less than the mass shown above.

## Monoblock Manifold Mass (single valve unit included)

g [oz.]

Monoblock manifold	Mass calculation of each unit			
	4(A), 2(B) ports outlet specifications			
	Female thread block	Dual use fitting block	φ 4 fitting block	φ 6 fitting block
A type	$(97 \times n) + 79$ [(3.42 × n) + 2.79]	$(101 \times n) + 79$ [(3.56 × n) + 2.79]	$(103 \times n) + 79$ [(3.63 × n) + 2.79]	$(106 \times n) + 79$ [(3.74 × n) + 2.79]
F type	$(71 \times n) + 57$ [(2.50 × n) + 2.01]	$(75 \times n) + 57$ [(2.65 × n) + 2.01]	$(77 \times n) + 57$ [(2.72 × n) + 2.01]	$(80 \times n) + 57$ [(2.82 × n) + 2.01]

g [oz.]

Monoblock manifold	Additional mass (wire-saving type)		
	Wiring specification		
	-F100N, -F101N	-F200N, -F201N, -F260N	-D250N, -D251N
A type	$164 + 4n$ [5.78 + 0.14n]	$166 + 4n$ [5.86 + 0.14n]	$170 + 4n$ [6.00 + 0.14n]
F type	$112 + 4n$ [3.95 + 0.14n]	$114 + 4n$ [4.02 + 0.14n]	$118 + 4n$ [4.16 + 0.14n]

Calculation example : F10M8AM

stn.1~stn.8 F10T1-A1-PS DC24V

$$(97 \times 8) + 79 = 855 \text{ g [30.16 oz.]}$$

When mounting the block-off plate, subtract 50 g [1.76 oz.] per unit from the above calculation result.

When mounting the F10□T0 specification valve, subtract 10 g [0.35 oz.] per unit from the above calculation result.

## PC Board Manifold Mass (single valve unit included)

g [oz.]

PC board manifold	Mass calculation of each unit				Circuit board and connector portion
	4(A), 2(B) ports outlet specifications				
	Female thread block	Dual use fitting block	φ 4 fitting block	φ 6 fitting block	
A type	$(97 \times n) + 79$ [(3.42 × n) + 2.79]	$(101 \times n) + 79$ [(3.56 × n) + 2.79]	$(103 \times n) + 79$ [(3.63 × n) + 2.79]	$(106 \times n) + 79$ [(3.74 × n) + 2.79]	$(2 \times n) + 29$ [(0.07 × n) + 1.02]
F type	$(76 \times n) + 83$ [(2.68 × n) + 2.93]	$(80 \times n) + 83$ [(2.82 × n) + 2.93]	$(82 \times n) + 83$ [(2.89 × n) + 2.93]	$(85 \times n) + 83$ [(3.00 × n) + 2.93]	

Calculation example : F10M8APM-F201-W

stn.1~stn.8 F10T1-A1-PP DC24V

$$(97 \times 8) + 79 + (2 \times 8) + 29 = 900 \text{ g [31.75 oz.]}$$

When mounting the block-off plate, subtract 50 g [1.76 oz.] per unit from the above calculation result.

When mounting the F10□T0 specification valve, subtract 10 g [0.35 oz.] per unit from the above calculation result.

# Mass

## Mass of Split Manifold and Serial Transmission Compatible Manifold

Because the valve and manifold have the same output specifications, their mass is the same. The mass can only be changed by choosing a different type of inlet/outlet block.

### Mass of Split Manifold Non-Plug-in Type (single valve unit included)

g [oz.]

Non-plug-in type	Mass calculation of each unit			
	4(A), 2(B) ports outlet specifications			
	Female thread block	Dual use fitting block	φ 4 fitting block	φ 6 fitting block
	$(75 \times n) + 120$ [(2.65 × n) + 4.23]	$(79 \times n) + 120$ [(2.79 × n) + 4.23]	$(81 \times n) + 120$ [(2.86 × n) + 4.23]	$(84 \times n) + 120$ [(2.96 × n) + 4.23]

g [oz.]

Additional mass			
Piping block specification			
Female thread block	Dual use fitting block	φ 8 fitting block	φ 10 fitting block
111 [3.92]	125 [4.41]	149 [5.26]	159 [5.61]

Calculation example : **F10M8N-MR**

**stn.1~stn.8 F10T1-A1-PS DC24V**

$(75 \times 8) + 120 + 111 = 831$  g [29.31 oz.]

When mounting the block-off plate, subtract 50 g [1.76 oz] per unit from the above calculation result.

When mounting the **F10□T0** specification valve, subtract 10 g [0.35 oz.] per unit from the above calculation result.

### Mass of Split Manifold Plug-in Type/Serial Transmission Compatible Manifold (single valve unit included)

g [oz.]

Plug-in type Serial transmission compatible manifold	Mass calculation of each unit			
	4(A), 2(B) ports outlet specifications			
	Female thread block	Dual use fitting block	φ 4 fitting block	φ 6 fitting block
	$(79 \times n) + 120$ [(2.79 × n) + 4.23]	$(83 \times n) + 120$ [(2.93 × n) + 4.23]	$(85 \times n) + 120$ [(3.00 × n) + 4.23]	$(88 \times n) + 120$ [(3.10 × n) + 4.23]

g [oz.]

Additional mass			
Piping block specification			
Female thread block	Dual use fitting block	φ 8 fitting block	φ 10 fitting block
111 [3.92]	125 [4.41]	149 [5.26]	159 [5.61]

g [oz.]

Additional mass				
Wiring block specification				
-F100□□, -F101□□	-F200□□, -F201□□, -F260□□	-D250□□, -D251□□	-D370NU	-T200
32 [1.13]	34 [1.20]	39 [1.38]	72 [2.54]	110 [3.88]

g [oz.]

Additional mass			
Serial transmission block specification			
Stand-alone type	Integrated type	EtherCAT	EtherNet/IP
231 [8.15]	138 [4.87]	100 [3.53]	110 [3.88]

Calculation example : **F10M8PM-MR-F201 DC24V**

**stn.1~stn.8 F10T1-A1 DC24V**

$(79 \times 8) + 120 + 111 + 34 = 897$  g [31.64 oz.]

When mounting the block-off plate, subtract 50 g [1.76 oz] per unit from the above calculation result.

When mounting the **F10□T0** specification valve, subtract 10 g [0.35 oz.] per unit from the above calculation result.

**F10T Valve specifications -F3-PS**

With outlet port dual use fitting block  
 With inlet port female thread block  
 S type plug connector

\* For T0 Type dimensions, see page 112.

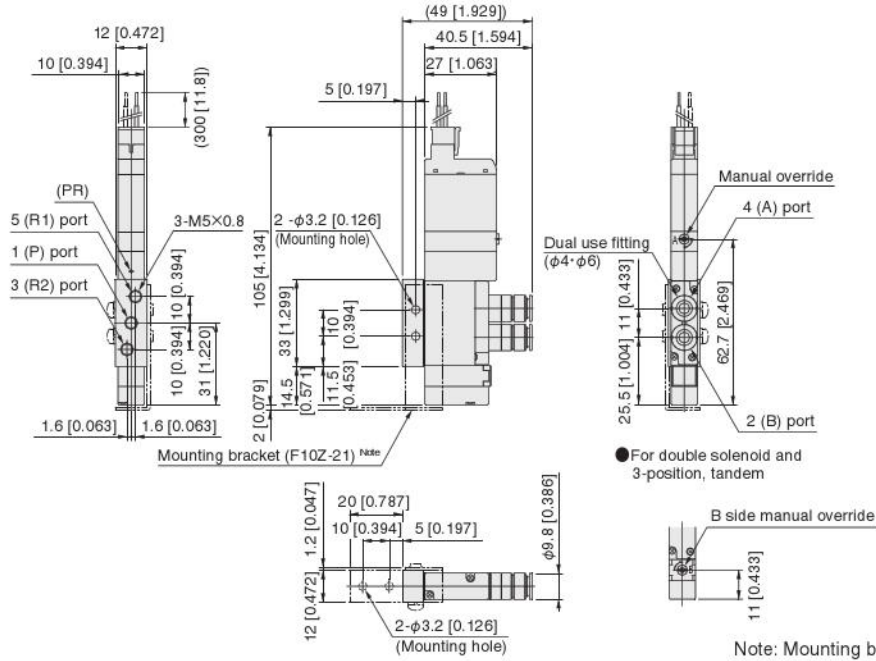

Note: Mounting brackets are additional parts (options).

**F10T Valve specifications -F4-PS**

**F10T Valve specifications -F4H-PS**

With outlet port female thread block  
 With inlet port female thread block  
 S type plug connector

\* For T0 Type dimensions, see page 112.

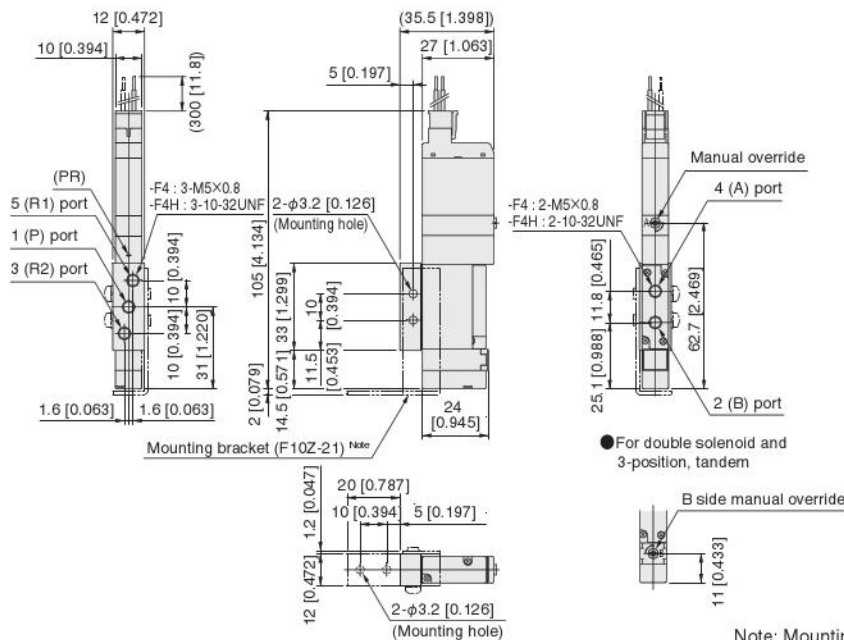

Note: Mounting brackets are additional parts (options).



Dimensions of F10 series single valve unit mm [in]

F10T Valve specifications Operation system -A2-PS

F10T Valve specifications Operation system -A2H-PS

With A-type sub-base  
S type plug connector

Internal pilot specifications

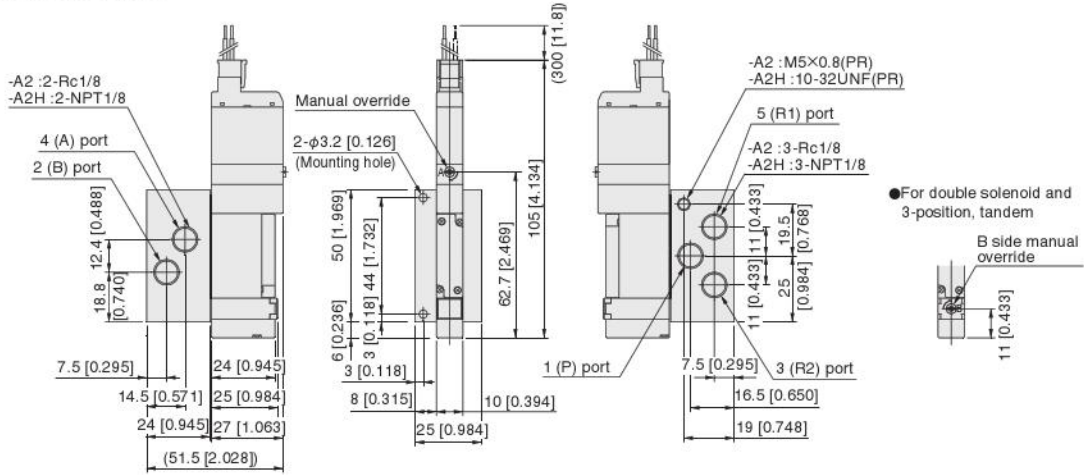

Note: The overall valve length of the T0 type is 8 mm [0.315 in] shorter (end cover side protrusion is 8 mm [0.315 in] less).

External pilot specifications

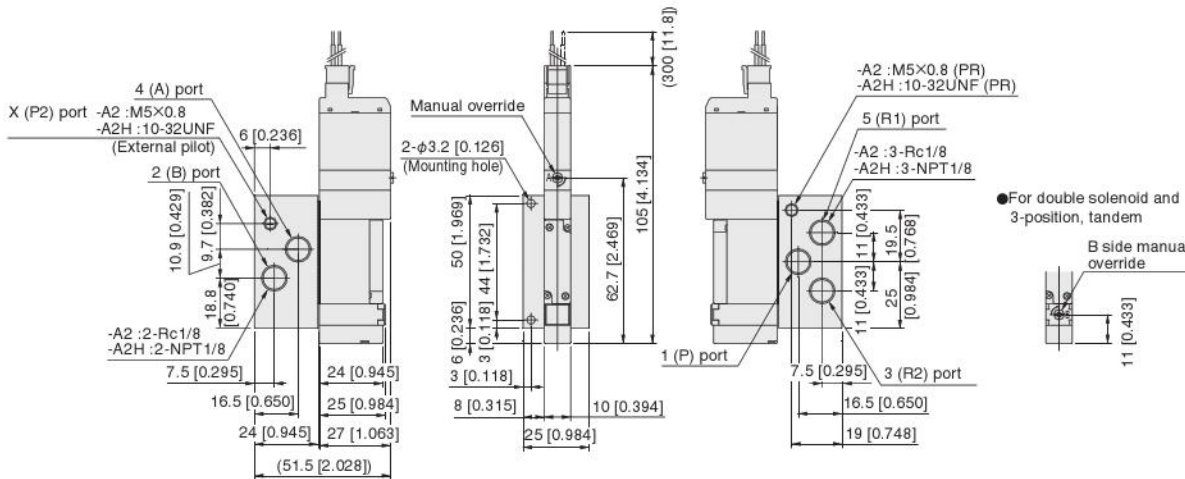

Note: The overall valve length of the T0 type is 8 mm [0.315 in] shorter (end cover side protrusion is 8 mm [0.315 in] less).

Options

L-type plug connector: -PL

Manual lever: -R

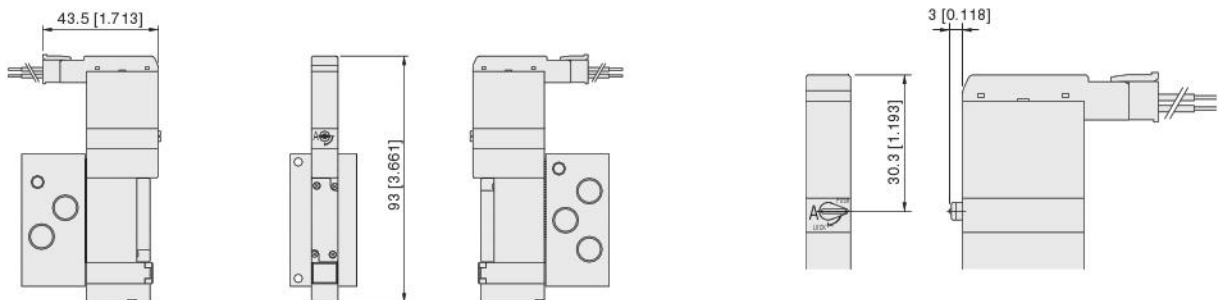

Note: The overall valve length of the T0 type is 8 mm [0.315 in] shorter (end cover side protrusion is 8 mm [0.315 in] less).

Dimensions of F10 series monoblock manifold A type mm [in]

**F10M** Number of valves **A M J** Pilot specifications (Base piping type)

Monoblock manifold A type  
 With manifold outlet port dual use fitting block  
 S type plug connector

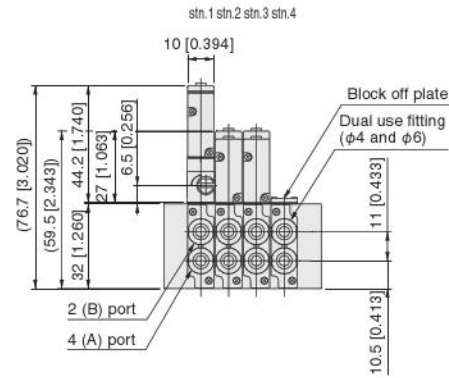
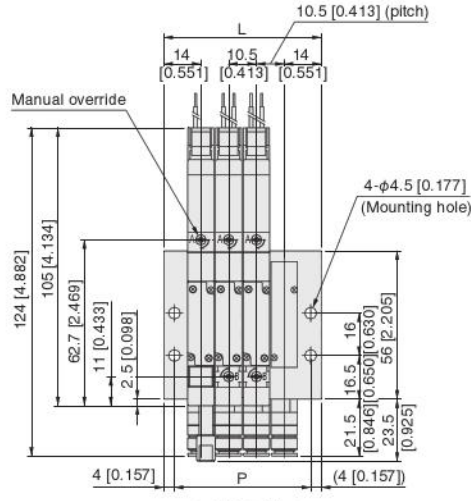
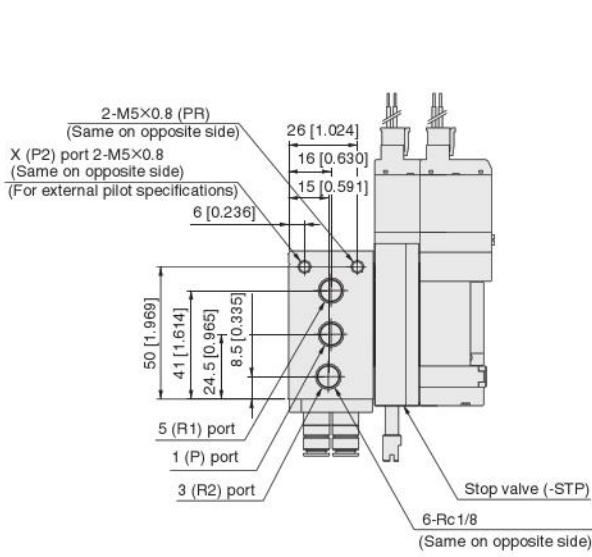

**Unit dimensions**

Number of units	L	P
2	38.5 [1.516]	30.5 [1.201]
3	49.0 [1.929]	41.0 [1.614]
4	59.5 [2.343]	51.5 [2.028]
5	70.0 [2.756]	62.0 [2.441]
6	80.5 [3.169]	72.5 [2.854]
7	91.0 [3.583]	83.0 [3.268]
8	101.5 [3.996]	93.5 [3.681]
9	112.0 [4.409]	104.0 [4.094]
10	122.5 [4.823]	114.5 [4.508]
11	133.0 [5.236]	125.0 [4.921]
12	143.5 [5.650]	135.5 [5.335]
13	154.0 [6.063]	146.0 [5.748]
14	164.5 [6.476]	156.5 [6.161]
15	175.0 [6.890]	167.0 [6.575]
16	185.5 [7.303]	177.5 [6.988]
17	196.0 [7.717]	188.0 [7.402]
18	206.5 [8.130]	198.5 [7.815]
19	217.0 [8.543]	209.0 [8.228]
20	227.5 [8.957]	219.5 [8.642]

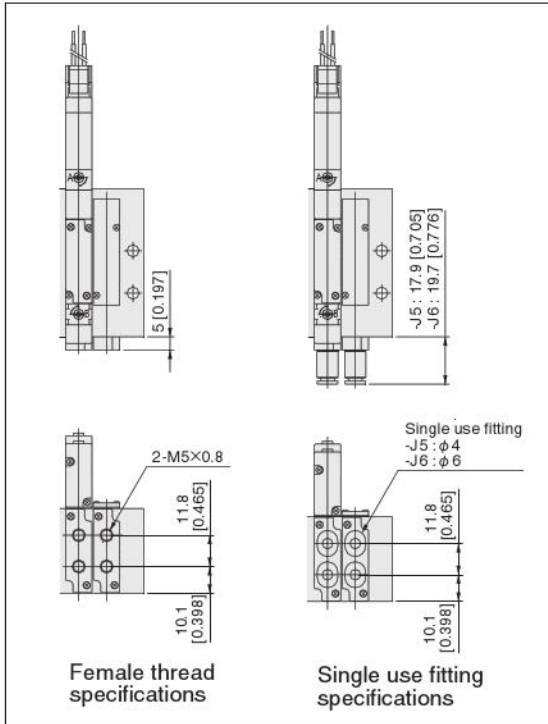

**Dimensions of F10 series monoblock manifold A type** mm [in]

**F10M** Number of valves **AHL** Pilot specifications (Base piping type)

Monoblock manifold A type  
 With manifold outlet port female thread block  
 S type plug connector

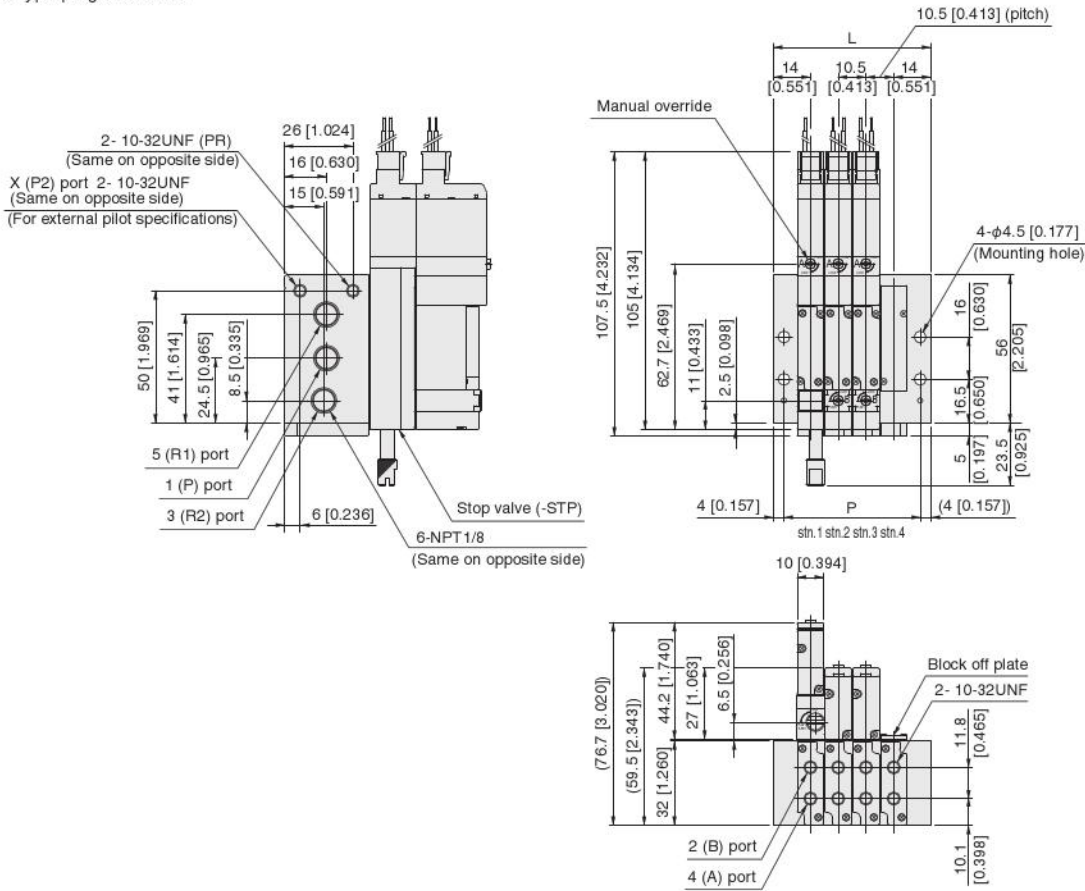

**Unit dimensions**

Number of units	L	P
2	38.5 [1.516]	30.5 [1.201]
3	49.0 [1.929]	41.0 [1.614]
4	59.5 [2.343]	51.5 [2.028]
5	70.0 [2.756]	62.0 [2.441]
6	80.5 [3.169]	72.5 [2.854]
7	91.0 [3.583]	83.0 [3.268]
8	101.5 [3.996]	93.5 [3.681]
9	112.0 [4.409]	104.0 [4.094]
10	122.5 [4.823]	114.5 [4.508]
11	133.0 [5.236]	125.0 [4.921]
12	143.5 [5.650]	135.5 [5.335]
13	154.0 [6.063]	146.0 [5.748]
14	164.5 [6.476]	156.5 [6.161]
15	175.0 [6.890]	167.0 [6.575]
16	185.5 [7.303]	177.5 [6.988]
17	196.0 [7.717]	188.0 [7.402]
18	206.5 [8.130]	198.5 [7.815]
19	217.0 [8.543]	209.0 [8.228]
20	227.5 [8.957]	219.5 [8.642]

**F10M** [Number of valves] **F** (Direct piping type)

Monoblock manifold F type  
 With valve outlet port dual use fitting block  
 S type plug connector

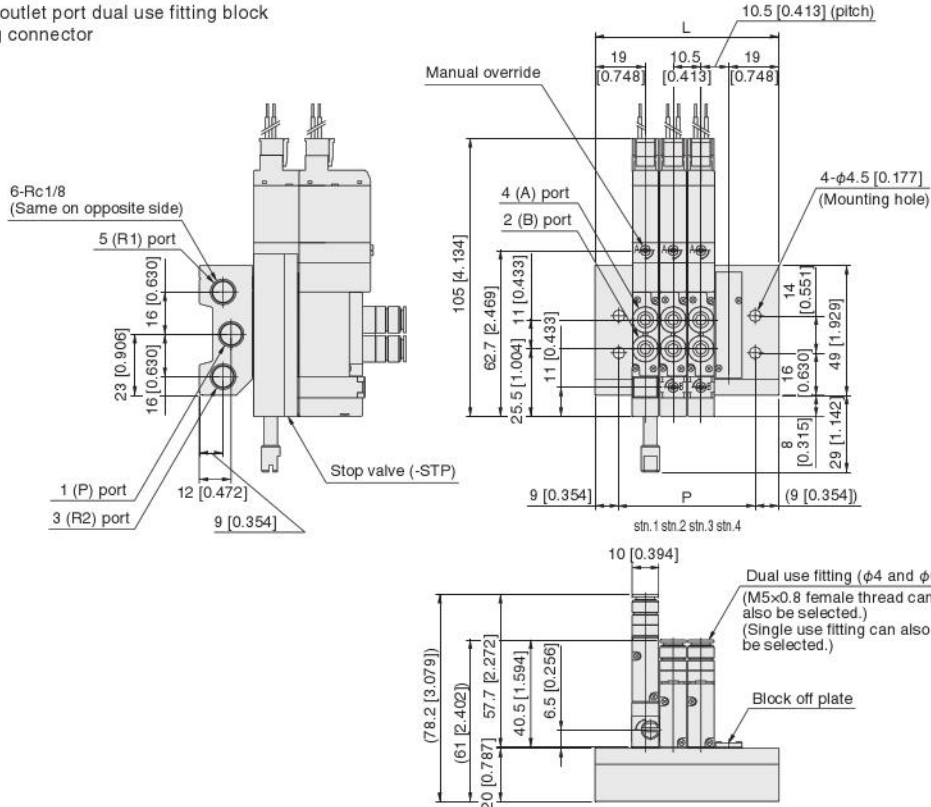

Note: The overall valve length of the T0 type is 8 mm [0.315 in] shorter (end cover side protrusion is 8 mm [0.315 in] less).

**Unit dimensions**

Number of units	L	P
2	48.5 [1.909]	30.5 [1.201]
3	59.0 [2.323]	41.0 [1.614]
4	69.5 [2.736]	51.5 [2.028]
5	80.0 [3.150]	62.0 [2.441]
6	90.5 [3.563]	72.5 [2.854]
7	101.0 [3.976]	83.0 [3.268]
8	111.5 [4.390]	93.5 [3.681]
9	122.0 [4.803]	104.0 [4.094]
10	132.5 [5.217]	114.5 [4.508]
11	143.0 [5.630]	125.0 [4.921]
12	153.5 [6.043]	135.5 [5.335]
13	164.0 [6.457]	146.0 [5.748]
14	174.5 [6.870]	156.5 [6.161]
15	185.0 [7.283]	167.0 [6.575]
16	195.5 [7.697]	177.5 [6.988]
17	206.0 [8.110]	188.0 [7.402]
18	216.5 [8.524]	198.5 [7.815]
19	227.0 [8.937]	209.0 [8.228]
20	237.5 [9.350]	219.5 [8.642]

**F10M** [Number of valves] **FH** (Direct piping type)

Monoblock manifold F type  
 With valve outlet port female thread block  
 S type plug connector

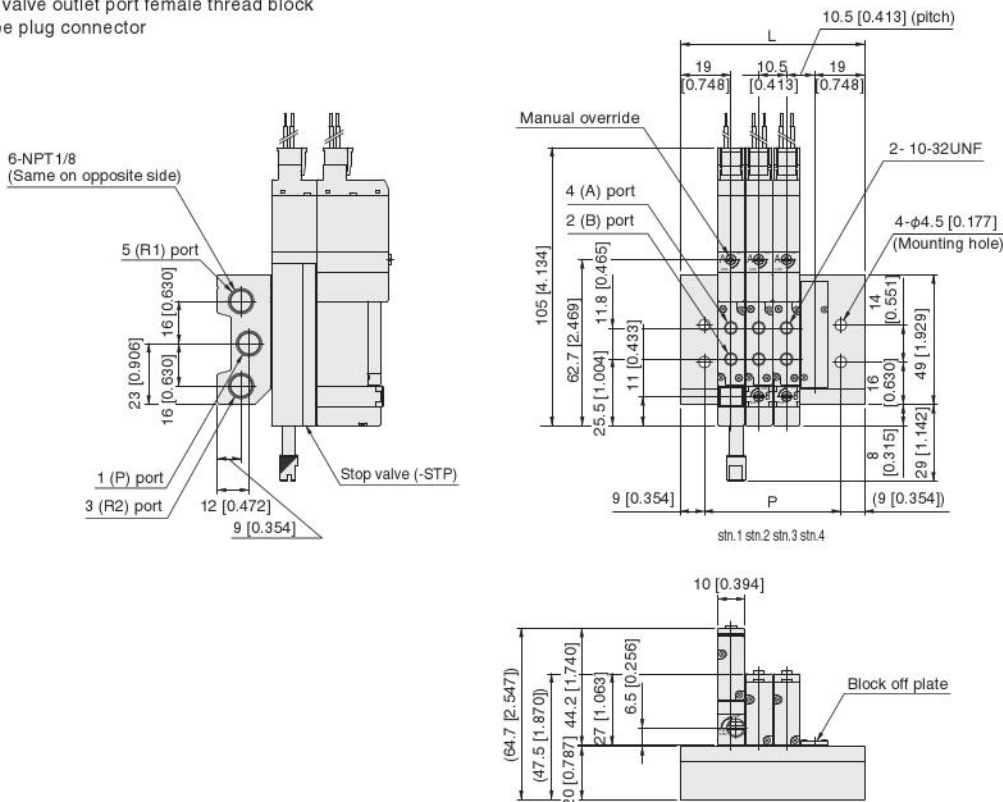

Note: The overall valve length of the T0 type is 8 mm [0.315 in] shorter (end cover side protrusion is 8 mm [0.315 in] less).

**Unit dimensions**

Number of units	L	P
2	48.5 [1.909]	30.5 [1.201]
3	59.0 [2.323]	41.0 [1.614]
4	69.5 [2.736]	51.5 [2.028]
5	80.0 [3.150]	62.0 [2.441]
6	90.5 [3.563]	72.5 [2.854]
7	101.0 [3.976]	83.0 [3.268]
8	111.5 [4.390]	93.5 [3.681]
9	122.0 [4.803]	104.0 [4.094]
10	132.5 [5.217]	114.5 [4.508]
11	143.0 [5.630]	125.0 [4.921]
12	153.5 [6.043]	135.5 [5.335]
13	164.0 [6.457]	146.0 [5.748]
14	174.5 [6.870]	156.5 [6.161]
15	185.0 [7.283]	167.0 [6.575]
16	195.5 [7.697]	177.5 [6.988]
17	206.0 [8.110]	188.0 [7.402]
18	216.5 [8.524]	198.5 [7.815]
19	227.0 [8.937]	209.0 [8.228]
20	237.5 [9.350]	219.5 [8.642]

**F10M** Number of valves **A** Pilot specifications (Base piping type)

Monoblock manifold A type, wire saving type  
 With manifold outlet port dual use fitting block  
 These dimensions show flat cable connector 20-pin specifications

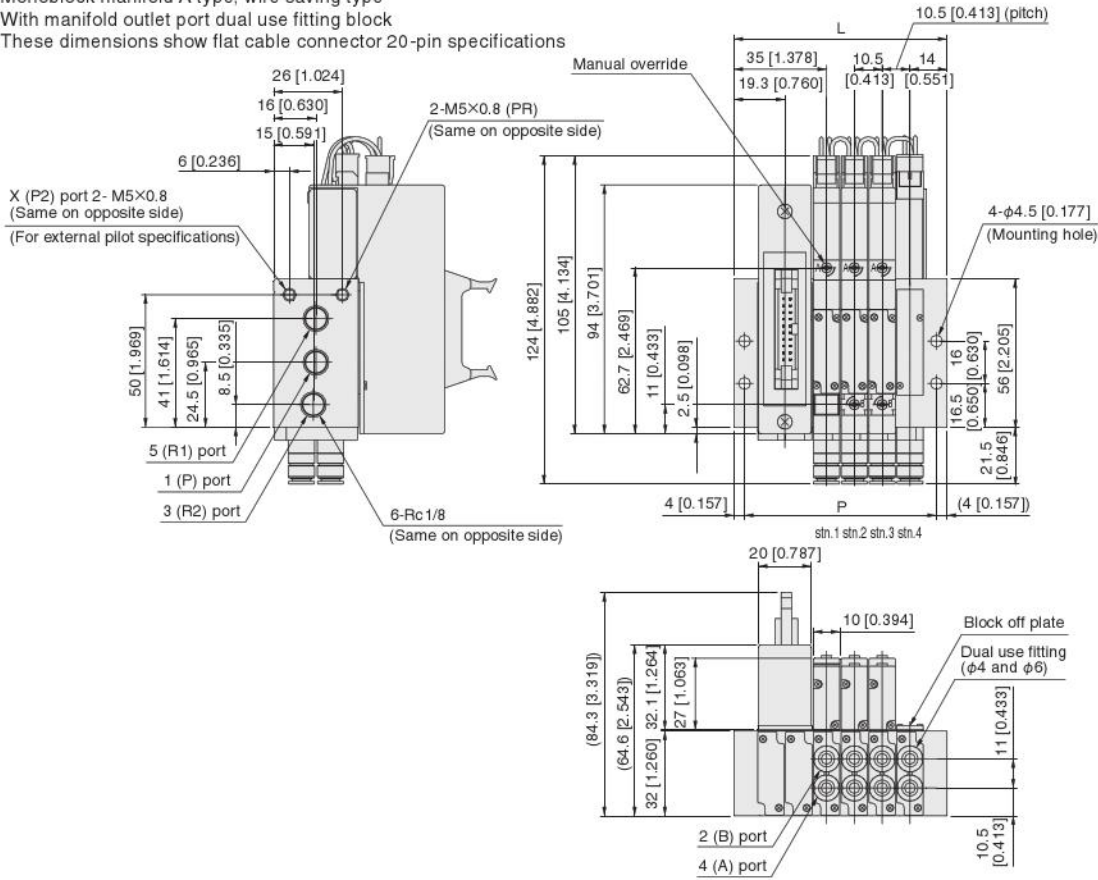

**Unit dimensions**

Number of units	L	P
2	59.5 [2.343]	51.5 [2.028]
3	70.0 [2.756]	62.0 [2.441]
4	80.5 [3.169]	72.5 [2.854]
5	91.0 [3.583]	83.0 [3.268]
6	101.5 [3.996]	93.5 [3.681]
7	112.0 [4.409]	104.0 [4.094]
8	122.5 [4.823]	114.5 [4.508]
9	133.0 [5.236]	125.0 [4.921]
10	143.5 [5.650]	135.5 [5.335]
11	154.0 [6.063]	146.0 [5.748]
12	164.5 [6.476]	156.5 [6.161]
13	175.0 [6.890]	167.0 [6.575]
14	185.5 [7.303]	177.5 [6.988]
15	196.0 [7.717]	188.0 [7.402]
16	206.5 [8.130]	198.5 [7.815]
17	217.0 [8.543]	209.0 [8.228]
18	227.5 [8.957]	219.5 [8.642]
19	238.0 [9.370]	230.0 [9.055]
20	248.5 [9.783]	240.5 [9.469]

**F10M** Number of valves **AHL** Pilot specifications (Base piping type)

Monoblock manifold A type, wire saving type  
 With manifold outlet port female thread block  
 These dimensions show flat cable connector 20-pin specifications

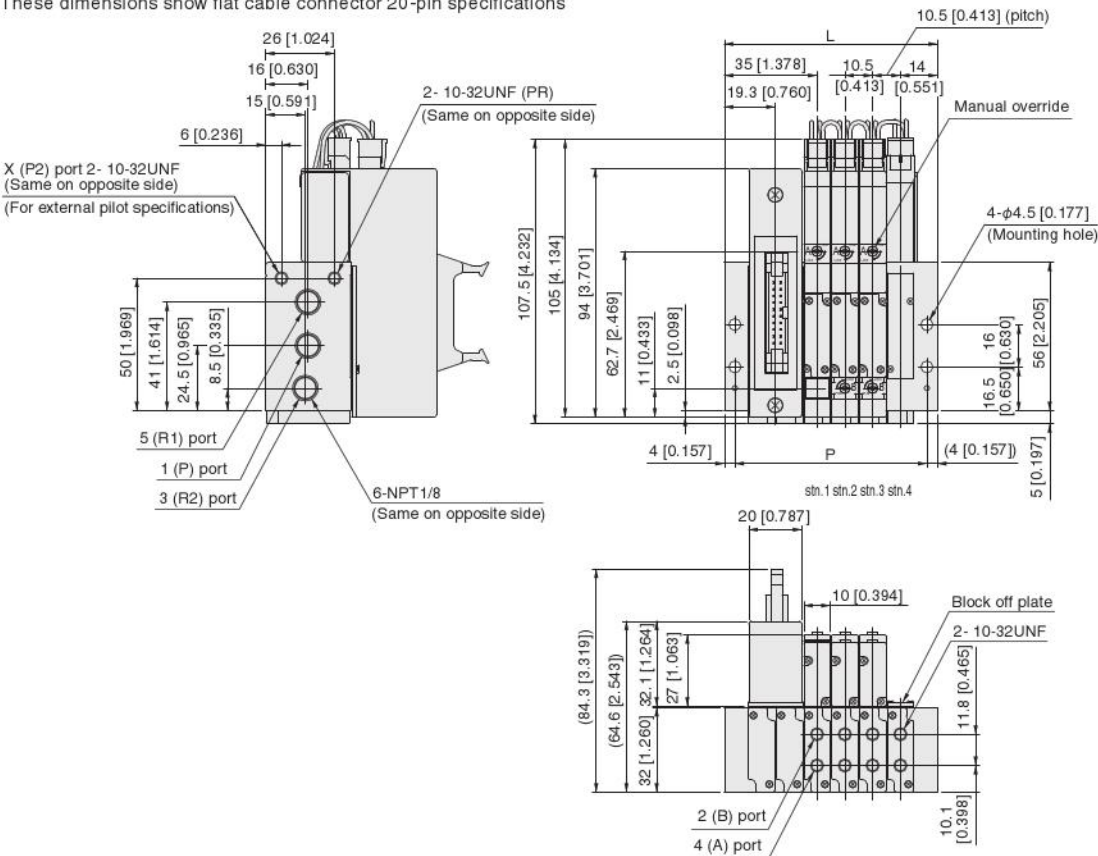

**Unit dimensions**

Number of units	L	P
2	59.5 [2.343]	51.5 [2.028]
3	70.0 [2.756]	62.0 [2.441]
4	80.5 [3.169]	72.5 [2.854]
5	91.0 [3.583]	83.0 [3.268]
6	101.5 [3.996]	93.5 [3.681]
7	112.0 [4.409]	104.0 [4.094]
8	122.5 [4.823]	114.5 [4.508]
9	133.0 [5.236]	125.0 [4.921]
10	143.5 [5.650]	135.5 [5.335]
11	154.0 [6.063]	146.0 [5.748]
12	164.5 [6.476]	156.5 [6.161]
13	175.0 [6.890]	167.0 [6.575]
14	185.5 [7.303]	177.5 [6.988]
15	196.0 [7.717]	188.0 [7.402]
16	206.5 [8.130]	198.5 [7.815]
17	217.0 [8.543]	209.0 [8.228]
18	227.5 [8.957]	219.5 [8.642]
19	238.0 [9.370]	230.0 [9.055]
20	248.5 [9.783]	240.5 [9.469]

**F10M** [Number of valves] **F** (Direct piping type)

Monoblock manifold F type, wire saving type  
 With valve outlet port dual use fitting block  
 These dimensions show flat cable connector 20-pin specifications

**Unit dimensions**

Number of units	L	P
2	69.5 [2.736]	51.5 [2.028]
3	80.0 [3.150]	62.0 [2.441]
4	90.5 [3.563]	72.5 [2.854]
5	101.0 [3.976]	83.0 [3.268]
6	111.5 [4.390]	93.5 [3.681]
7	122.0 [4.803]	104.0 [4.094]
8	132.5 [5.217]	114.5 [4.508]
9	143.0 [5.630]	125.0 [4.921]
10	153.5 [6.043]	135.5 [5.335]
11	164.0 [6.457]	146.0 [5.748]
12	174.5 [6.870]	156.5 [6.161]
13	185.0 [7.283]	167.0 [6.575]
14	195.5 [7.697]	177.5 [6.988]
15	206.0 [8.110]	188.0 [7.402]
16	216.5 [8.524]	198.5 [7.815]
17	227.0 [8.937]	209.0 [8.228]
18	237.5 [9.350]	219.5 [8.642]
19	248.0 [9.764]	230.0 [9.055]
20	258.5 [10.177]	240.5 [9.469]

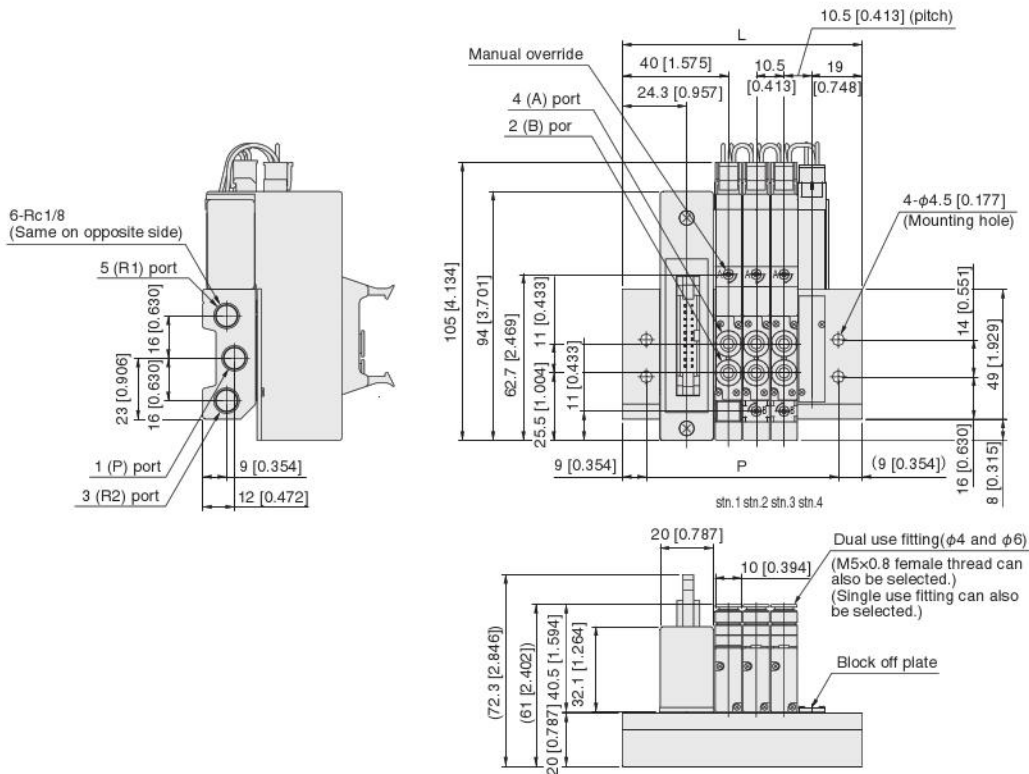

**F10M** [Number of valves] **FH** (Direct piping type)

Monoblock manifold F type, wire saving type  
 With valve outlet port female thread block  
 These dimensions show flat cable connector 20-pin specifications

**Unit dimensions**

Number of units	L	P
2	69.5 [2.736]	51.5 [2.028]
3	80.0 [3.150]	62.0 [2.441]
4	90.5 [3.563]	72.5 [2.854]
5	101.0 [3.976]	83.0 [3.268]
6	111.5 [4.390]	93.5 [3.681]
7	122.0 [4.803]	104.0 [4.094]
8	132.5 [5.217]	114.5 [4.508]
9	143.0 [5.630]	125.0 [4.921]
10	153.5 [6.043]	135.5 [5.335]
11	164.0 [6.457]	146.0 [5.748]
12	174.5 [6.870]	156.5 [6.161]
13	185.0 [7.283]	167.0 [6.575]
14	195.5 [7.697]	177.5 [6.988]
15	206.0 [8.110]	188.0 [7.402]
16	216.5 [8.524]	198.5 [7.815]
17	227.0 [8.937]	209.0 [8.228]
18	237.5 [9.350]	219.5 [8.642]
19	248.0 [9.764]	230.0 [9.055]
20	258.5 [10.177]	240.5 [9.469]

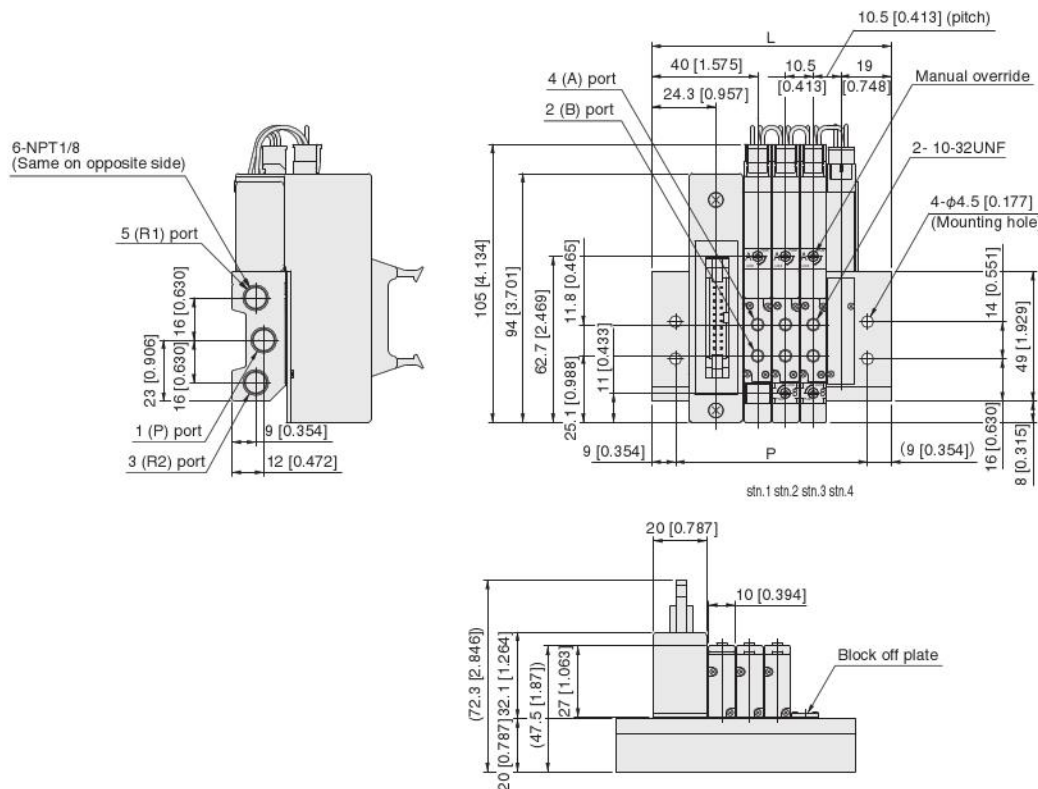

**F10M** [Number of valves] **AP<sup>M</sup>** [Pilot specifications] (Base piping type)

PC board manifold A type  
With manifold outlet port dual use fitting block

Note: Mounted valve example shows -W wiring specifications.  
In the case of -S wiring specifications, the mounted valve becomes T0 or T1 type.

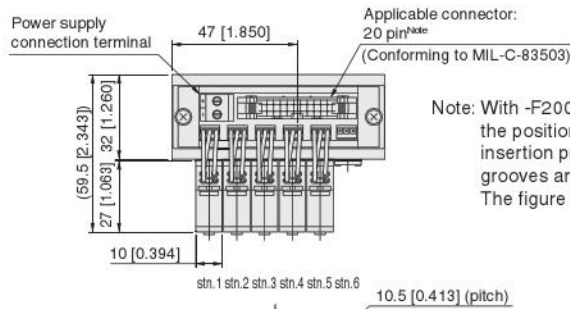

Note: With -F200 and -F201, the positions of the mis-insertion prevention grooves are reversed. The figure shows -F200.

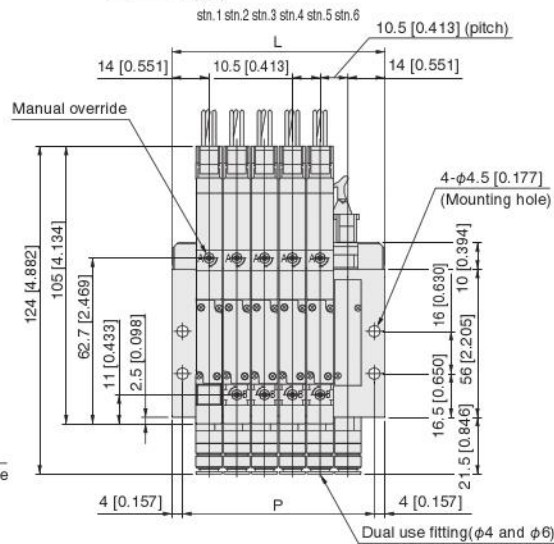
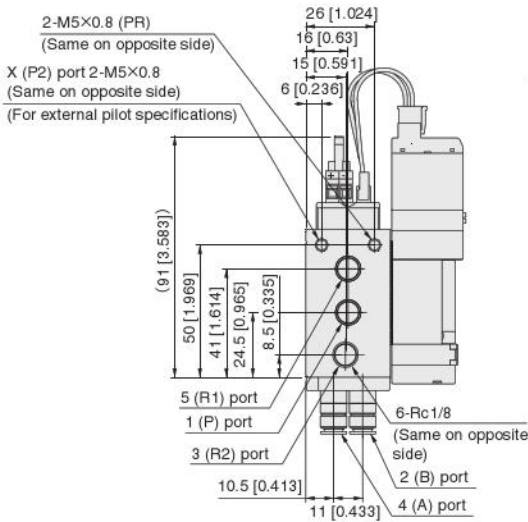

**Unit dimensions**

Number of units	L	P
6	80.5 [3.169]	72.5 [2.854]
8	101.5 [3.996]	93.5 [3.681]
10	122.5 [4.823]	114.5 [4.508]
12	143.5 [5.650]	135.5 [5.335]
14	164.5 [6.477]	156.5 [6.161]
16	185.5 [7.303]	177.5 [6.988]

Note: Wiring specifications  
For -S  
6, 8, 10, 12, 14, 16 units

For -W  
Only 6 and 8 units selectable

**F10M** [Number of valves] **FP** (Direct piping type)

PC board manifold F type  
With valve outlet port dual use fitting block

Note: Mounted valve example shows -W wiring specifications.  
In the case of -S wiring specifications, the mounted valve becomes T0 or T1 type.

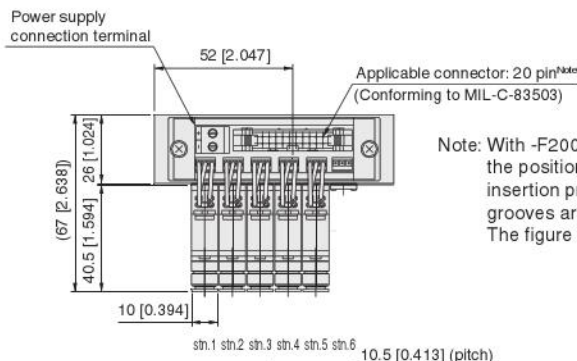

Note: With -F200 and -F201, the positions of the mis-insertion prevention grooves are reversed. The figure shows -F200.

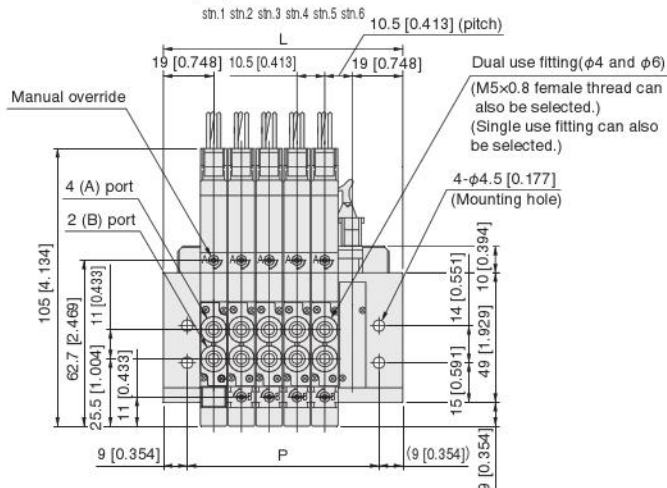
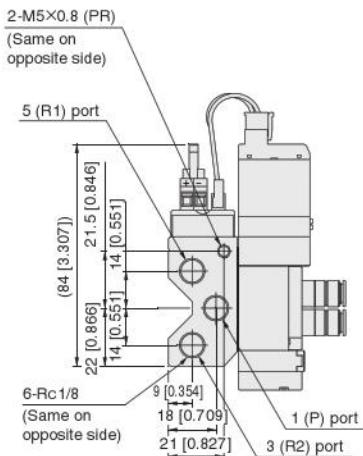

**Unit dimensions**

Number of units	L	P
6	90.5 [3.563]	72.5 [2.854]
8	111.5 [4.390]	93.5 [3.681]
10	132.5 [5.217]	114.5 [4.508]
12	153.5 [6.043]	135.5 [5.335]
14	174.5 [6.870]	156.5 [6.161]
16	195.5 [7.697]	177.5 [6.988]

Note: Wiring specifications  
For -S  
6, 8, 10, 12, 14, 16 units

For -W  
Only 6 and 8 units selectable

Note: The overall valve length of the T0 type is 8 mm [0.315 in] shorter (end cover side protrusion is 8 mm [0.315 in] less).

# Dimensions of F10 series split manifold non-plug-in type mm [in]

## F10M Number of valves N M Pilot specifications (Base piping type)

With manifold outlet port dual use fitting block  
S type plug connector

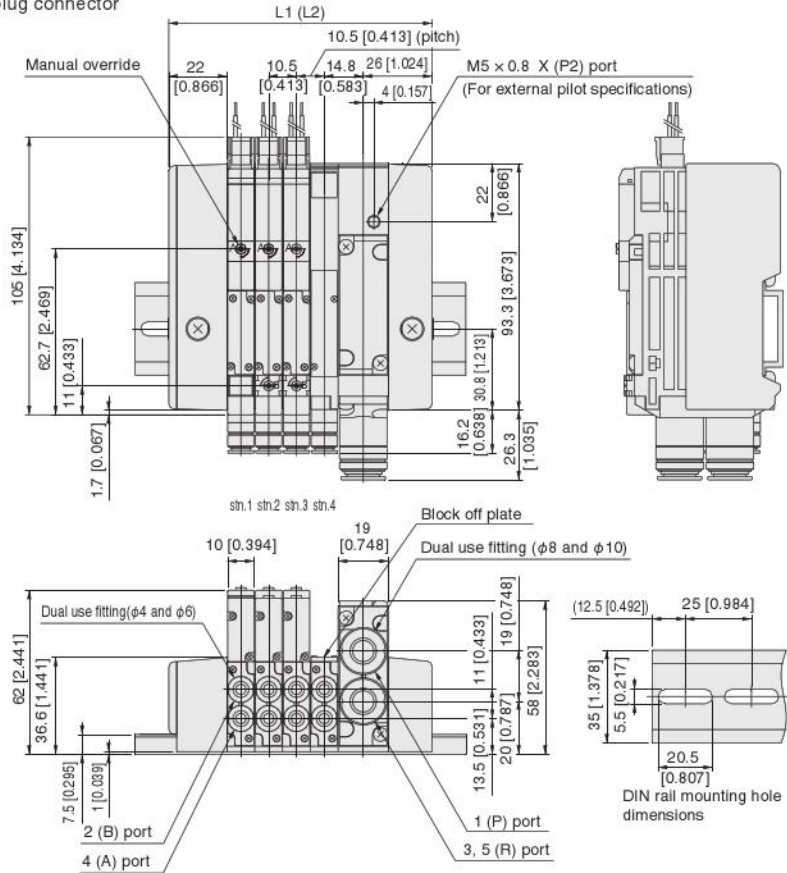

### Unit dimensions

Number of units	L1	Length of DIN rail	L2 <small>Note</small>	Length of DIN rail <small>Note</small>
2	78.5 [3.091]	125 [4.921]	97.5 [3.839]	125 [4.921]
3	89.0 [3.504]	125 [4.921]	108.0 [4.252]	150 [5.906]
4	99.5 [3.917]	125 [4.921]	118.5 [4.665]	150 [5.906]
5	110.0 [4.331]	150 [5.906]	129.0 [5.079]	175 [6.890]
6	120.5 [4.744]	150 [5.906]	139.5 [5.492]	175 [6.890]
7	131.0 [5.157]	175 [6.890]	150.0 [5.906]	175 [6.890]
8	141.5 [5.571]	175 [6.890]	160.5 [6.319]	200 [7.874]
9	152.0 [5.984]	200 [7.874]	171.0 [6.732]	200 [7.874]
10	162.5 [6.398]	200 [7.874]	181.5 [7.146]	225 [8.858]
11	173.0 [6.811]	200 [7.874]	192.0 [7.559]	225 [8.858]
12	183.5 [7.224]	225 [8.858]	202.5 [7.972]	250 [9.843]
13	194.0 [7.638]	225 [8.858]	213.0 [8.386]	250 [9.843]
14	204.5 [8.051]	250 [9.843]	223.5 [8.799]	250 [9.843]
15	215.0 [8.465]	250 [9.843]	234.0 [9.213]	275 [10.827]
16	225.5 [8.878]	275 [10.827]	244.5 [9.626]	275 [10.827]
17	236.0 [9.291]	275 [10.827]	255.0 [10.039]	300 [11.811]
18	246.5 [9.705]	275 [10.827]	265.5 [10.453]	300 [11.811]
19	257.0 [10.118]	300 [11.811]	276.0 [10.866]	325 [12.795]
20	267.5 [10.531]	300 [11.811]	286.5 [11.280]	325 [12.795]

Note: When two piping blocks are used.

## F10M Number of valves N Pilot specifications (Direct piping type)

With valve outlet port dual use fitting block  
S type plug connector

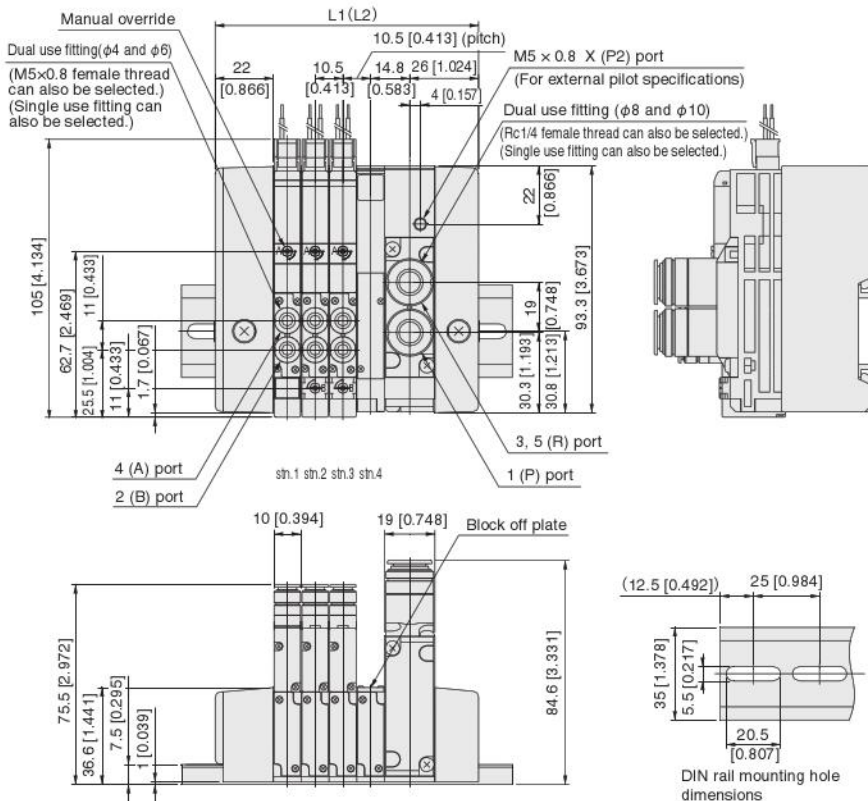

### Unit dimensions

Number of units	L1	Length of DIN rail	L2 <small>Note</small>	Length of DIN rail <small>Note</small>
2	78.5 [3.091]	125 [4.921]	97.5 [3.839]	125 [4.921]
3	89.0 [3.504]	125 [4.921]	108.0 [4.252]	150 [5.906]
4	99.5 [3.917]	125 [4.921]	118.5 [4.665]	150 [5.906]
5	110.0 [4.331]	150 [5.906]	129.0 [5.079]	175 [6.890]
6	120.5 [4.744]	150 [5.906]	139.5 [5.492]	175 [6.890]
7	131.0 [5.157]	175 [6.890]	150.0 [5.906]	175 [6.890]
8	141.5 [5.571]	175 [6.890]	160.5 [6.319]	200 [7.874]
9	152.0 [5.984]	200 [7.874]	171.0 [6.732]	200 [7.874]
10	162.5 [6.398]	200 [7.874]	181.5 [7.146]	225 [8.858]
11	173.0 [6.811]	200 [7.874]	192.0 [7.559]	225 [8.858]
12	183.5 [7.224]	225 [8.858]	202.5 [7.972]	250 [9.843]
13	194.0 [7.638]	225 [8.858]	213.0 [8.386]	250 [9.843]
14	204.5 [8.051]	250 [9.843]	223.5 [8.799]	250 [9.843]
15	215.0 [8.465]	250 [9.843]	234.0 [9.213]	275 [10.827]
16	225.5 [8.878]	275 [10.827]	244.5 [9.626]	275 [10.827]
17	236.0 [9.291]	275 [10.827]	255.0 [10.039]	300 [11.811]
18	246.5 [9.705]	275 [10.827]	265.5 [10.453]	300 [11.811]
19	257.0 [10.118]	300 [11.811]	276.0 [10.866]	325 [12.795]
20	267.5 [10.531]	300 [11.811]	286.5 [11.280]	325 [12.795]

Note: When two piping blocks are used.

Note: The overall valve length of the T0 type is 8 mm [0.315 in] shorter (end cover side protrusion is 8 mm [0.315 in] less).

# Dimensions of F10 series split manifold non-plug-in type mm [in]

## F10M Number of valves NHL Pilot specifications (Base piping type)

With manifold outlet port female thread block  
S type plug connector

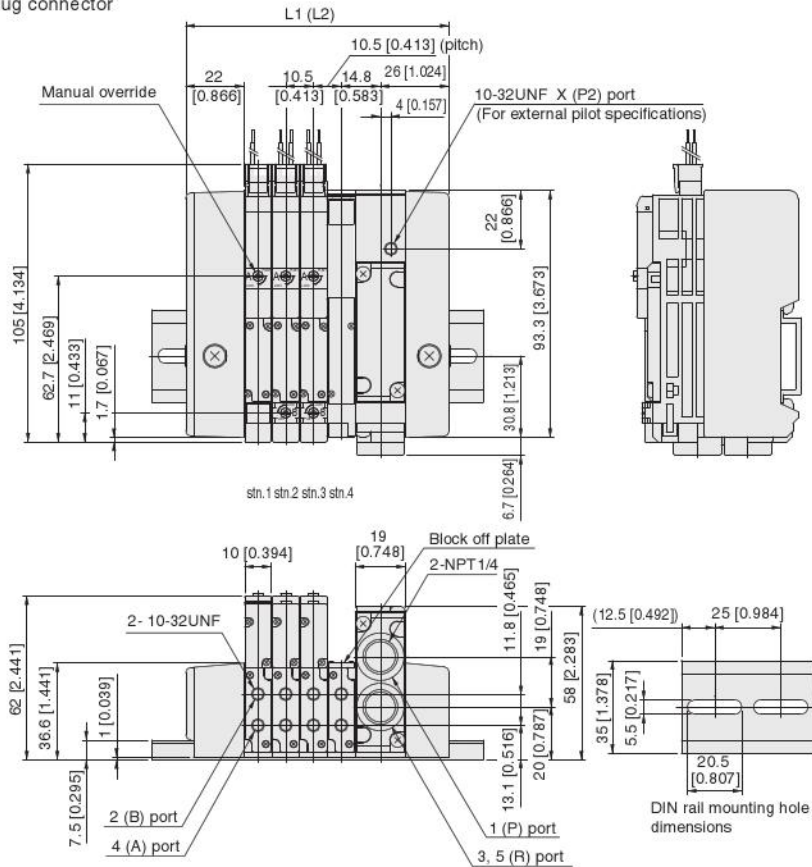

### Unit dimensions

Number of units	L1	Length of DIN rail	L2 <small>Note</small>	Length of DIN rail <small>Note</small>
2	78.5 [3.091]	125 [4.921]	97.5 [3.839]	125 [4.921]
3	89.0 [3.504]	125 [4.921]	108.0 [4.252]	150 [5.906]
4	99.5 [3.917]	125 [4.921]	118.5 [4.665]	150 [5.906]
5	110.0 [4.331]	150 [5.906]	129.0 [5.079]	175 [6.890]
6	120.5 [4.744]	150 [5.906]	139.5 [5.492]	175 [6.890]
7	131.0 [5.157]	175 [6.890]	150.0 [5.906]	175 [6.890]
8	141.5 [5.571]	175 [6.890]	160.5 [6.319]	200 [7.874]
9	152.0 [5.984]	200 [7.874]	171.0 [6.732]	200 [7.874]
10	162.5 [6.398]	200 [7.874]	181.5 [7.146]	225 [8.858]
11	173.0 [6.811]	200 [7.874]	192.0 [7.559]	225 [8.858]
12	183.5 [7.224]	225 [8.858]	202.5 [7.972]	250 [9.843]
13	194.0 [7.638]	225 [8.858]	213.0 [8.386]	250 [9.843]
14	204.5 [8.051]	250 [9.843]	223.5 [8.799]	250 [9.843]
15	215.0 [8.465]	250 [9.843]	234.0 [9.213]	275 [10.827]
16	225.5 [8.878]	275 [10.827]	244.5 [9.626]	275 [10.827]
17	236.0 [9.291]	275 [10.827]	255.0 [10.039]	300 [11.811]
18	246.5 [9.705]	275 [10.827]	265.5 [10.453]	300 [11.811]
19	257.0 [10.118]	300 [11.811]	276.0 [10.866]	325 [12.795]
20	267.5 [10.531]	300 [11.811]	286.5 [11.280]	325 [12.795]

Note: When two piping blocks are used.

## F10M Number of valves NH Pilot specifications (Direct piping type)

With valve outlet port female thread block  
S type plug connector

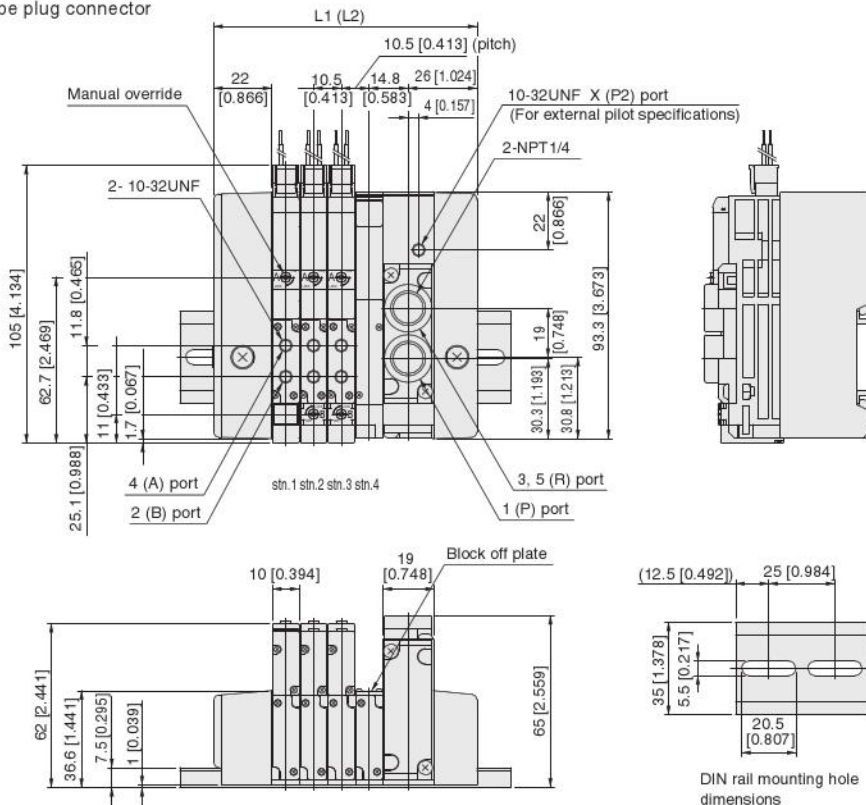

### Unit dimensions

Number of units	L1	Length of DIN rail	L2 <small>Note</small>	Length of DIN rail <small>Note</small>
2	78.5 [3.091]	125 [4.921]	97.5 [3.839]	125 [4.921]
3	89.0 [3.504]	125 [4.921]	108.0 [4.252]	150 [5.906]
4	99.5 [3.917]	125 [4.921]	118.5 [4.665]	150 [5.906]
5	110.0 [4.331]	150 [5.906]	129.0 [5.079]	175 [6.890]
6	120.5 [4.744]	150 [5.906]	139.5 [5.492]	175 [6.890]
7	131.0 [5.157]	175 [6.890]	150.0 [5.906]	175 [6.890]
8	141.5 [5.571]	175 [6.890]	160.5 [6.319]	200 [7.874]
9	152.0 [5.984]	200 [7.874]	171.0 [6.732]	200 [7.874]
10	162.5 [6.398]	200 [7.874]	181.5 [7.146]	225 [8.858]
11	173.0 [6.811]	200 [7.874]	192.0 [7.559]	225 [8.858]
12	183.5 [7.224]	225 [8.858]	202.5 [7.972]	250 [9.843]
13	194.0 [7.638]	225 [8.858]	213.0 [8.386]	250 [9.843]
14	204.5 [8.051]	250 [9.843]	223.5 [8.799]	250 [9.843]
15	215.0 [8.465]	250 [9.843]	234.0 [9.213]	275 [10.827]
16	225.5 [8.878]	275 [10.827]	244.5 [9.626]	275 [10.827]
17	236.0 [9.291]	275 [10.827]	255.0 [10.039]	300 [11.811]
18	246.5 [9.705]	275 [10.827]	265.5 [10.453]	300 [11.811]
19	257.0 [10.118]	300 [11.811]	276.0 [10.866]	325 [12.795]
20	267.5 [10.531]	300 [11.811]	286.5 [11.280]	325 [12.795]

Note: When two piping blocks are used.

Note: The overall valve length of the T0 type is 8 mm [0.315 in] shorter (end cover side protrusion is 8 mm [0.315 in] less).

# Dimensions of F10 series split manifold plug-in type mm [in]

## F10M Number of valves P M L Pilot specifications (Base piping type)

With manifold outlet port dual use fitting block  
Flat cable connector 10-pin specifications

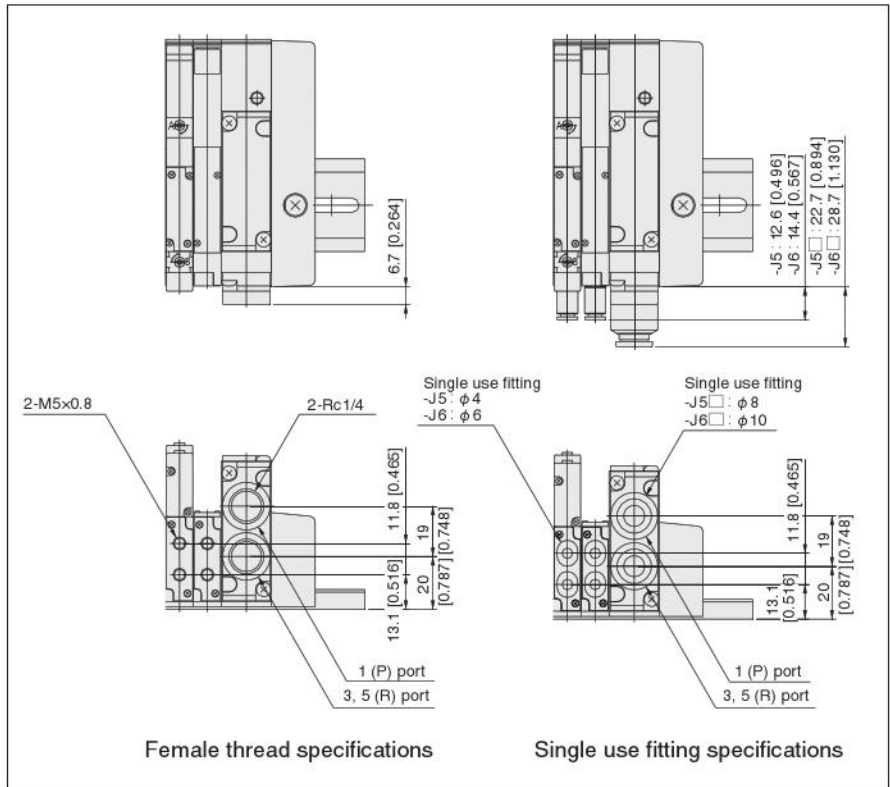
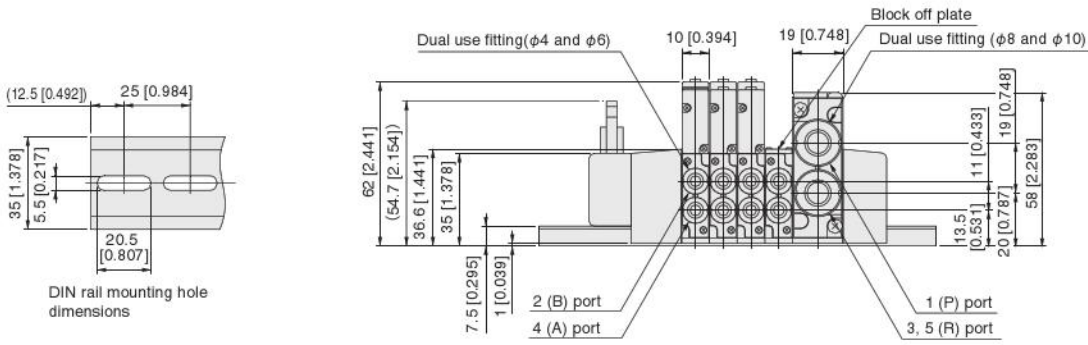
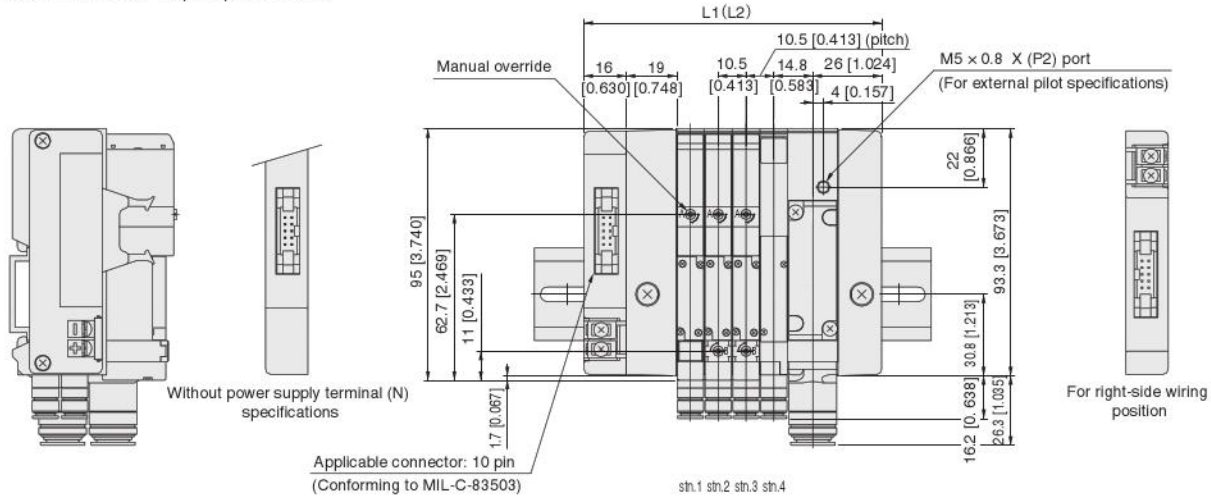

### Unit dimensions

Number of units	L1	Length of DIN rail	L2 <small>Note</small>	Length of DIN rail <small>Note</small>
2	91.5 [3.602]	125 [4.921]	110.5 [4.350]	150 [5.906]
3	102.0 [4.016]	150 [5.906]	121.0 [4.764]	175 [6.890]
4	112.5 [4.429]	150 [5.906]	131.5 [5.177]	175 [6.890]
5	123.0 [4.843]	175 [6.890]	142.0 [5.591]	175 [6.890]
6	133.5 [5.256]	175 [6.890]	152.5 [6.004]	200 [7.874]
7	144.0 [5.669]	200 [7.874]	163.0 [6.417]	200 [7.874]
8	154.5 [6.083]	200 [7.874]	173.5 [6.831]	225 [8.858]

Note: When two piping blocks are used.  
\*For right-side mounting wiring (-R), add 5.5 mm [0.217 in] to the L1 (L2) dimension.

Dimensions of F10 series split manifold plug-in type mm [in]

**F10M** [Number of valves] **P M L** [Pilot specifications] (Base piping type)

With manifold outlet port dual use fitting block  
Flat cable connector 20-pin specifications (side surface wiring)

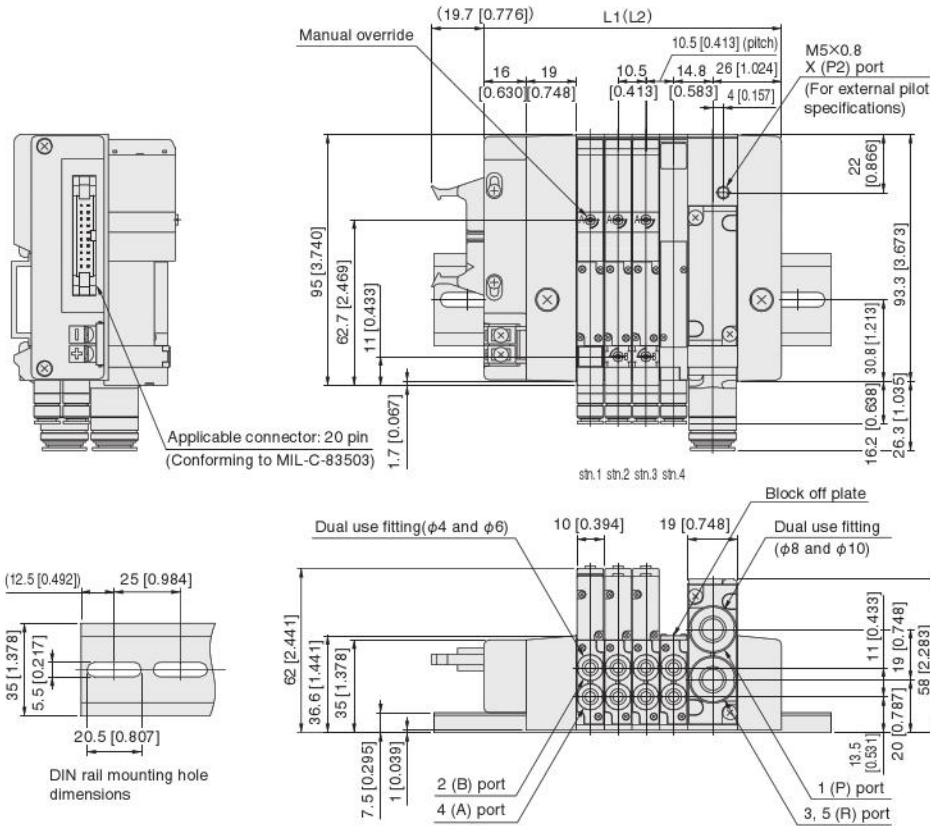

**Unit dimensions**

Number of units	L1	Length of DIN rail	L2	Length of DIN rail
2	91.5 [3.602]	125 [4.921]	110.5 [4.350]	150 [5.906]
3	102.0 [4.016]	150 [5.906]	121.0 [4.764]	175 [6.890]
4	112.5 [4.429]	150 [5.906]	131.5 [5.177]	175 [6.890]
5	123.0 [4.843]	175 [6.890]	142.0 [5.591]	175 [6.890]
6	133.5 [5.256]	175 [6.890]	152.5 [6.004]	200 [7.874]
7	144.0 [5.669]	200 [7.874]	163.0 [6.417]	200 [7.874]
8	154.5 [6.083]	200 [7.874]	173.5 [6.831]	225 [8.858]
9	165.0 [6.496]	200 [7.874]	184.0 [7.244]	225 [8.858]
10	175.5 [6.909]	225 [8.858]	194.5 [7.657]	250 [9.843]
11	186.0 [7.323]	225 [8.858]	205.0 [8.071]	250 [9.843]
12	196.5 [7.736]	250 [9.843]	215.5 [8.484]	250 [9.843]
13	207.0 [8.150]	250 [9.843]	226.0 [8.898]	275 [10.827]
14	217.5 [8.563]	275 [10.827]	236.5 [9.311]	275 [10.827]
15	228.0 [8.976]	275 [10.827]	247.0 [9.724]	300 [11.811]
16	238.5 [9.390]	275 [10.827]	257.5 [10.138]	300 [11.811]

Note: When two piping blocks are used.  
\*For right-side mounting wiring (-R), add 5.5 mm [0.217 in] to the L1 (L2) dimension.

**F10M** [Number of valves] **P M L** [Pilot specifications] (Base piping type)

With manifold outlet port dual use fitting block  
Flat cable connector 26-pin specifications

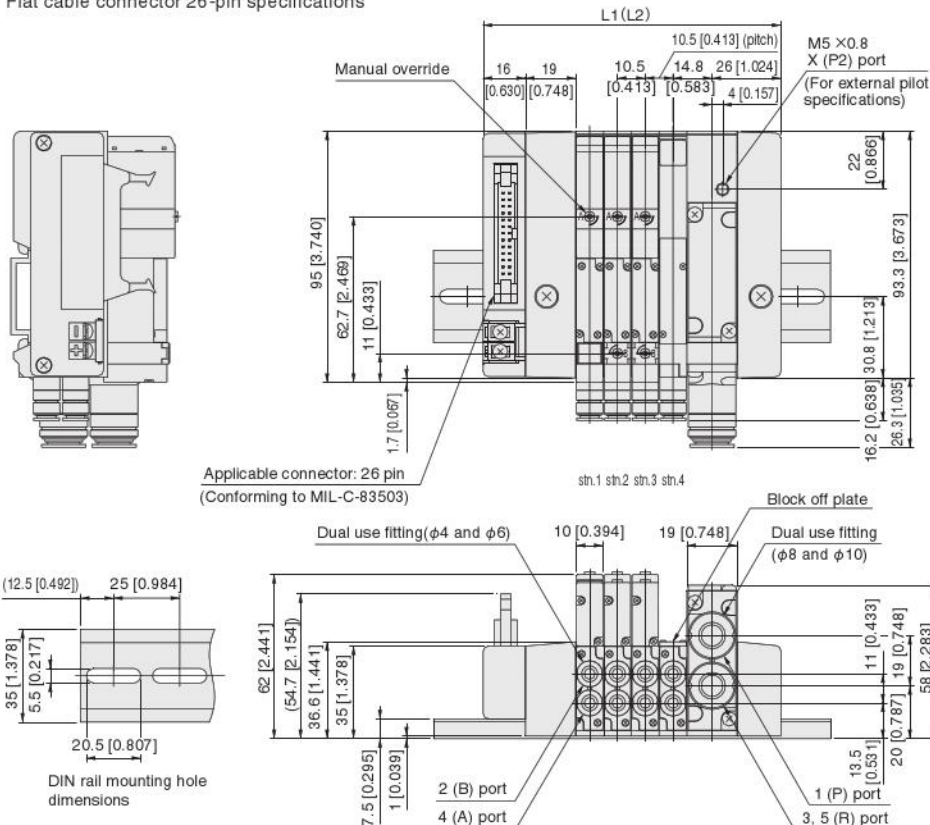

**Unit dimensions**

Number of units	L1	Length of DIN rail	L2	Length of DIN rail
2	91.5 [3.602]	125 [4.921]	110.5 [4.350]	150 [5.906]
3	102.0 [4.016]	150 [5.906]	121.0 [4.764]	175 [6.890]
4	112.5 [4.429]	150 [5.906]	131.5 [5.177]	175 [6.890]
5	123.0 [4.843]	175 [6.890]	142.0 [5.591]	175 [6.890]
6	133.5 [5.256]	175 [6.890]	152.5 [6.004]	200 [7.874]
7	144.0 [5.669]	200 [7.874]	163.0 [6.417]	200 [7.874]
8	154.5 [6.083]	200 [7.874]	173.5 [6.831]	225 [8.858]
9	165.0 [6.496]	200 [7.874]	184.0 [7.244]	225 [8.858]
10	175.5 [6.909]	225 [8.858]	194.5 [7.657]	250 [9.843]
11	186.0 [7.323]	225 [8.858]	205.0 [8.071]	250 [9.843]
12	196.5 [7.736]	250 [9.843]	215.5 [8.484]	250 [9.843]
13	207.0 [8.150]	250 [9.843]	226.0 [8.898]	275 [10.827]
14	217.5 [8.563]	275 [10.827]	236.5 [9.311]	275 [10.827]
15	228.0 [8.976]	275 [10.827]	247.0 [9.724]	300 [11.811]
16	238.5 [9.390]	275 [10.827]	257.5 [10.138]	300 [11.811]
17	249.0 [9.803]	300 [11.811]	268.0 [10.551]	325 [12.795]
18	259.5 [10.217]	300 [11.811]	278.5 [10.965]	325 [12.795]
19	270.0 [10.630]	325 [12.795]	289.0 [11.378]	325 [12.795]
20	280.5 [11.043]	325 [12.795]	299.5 [11.791]	350 [13.780]

Note: When two piping blocks are used.  
\*For right-side mounting wiring (-R), add 5.5 mm [0.217 in] to the L1 (L2) dimension.

# Dimensions of F10 series split manifold plug-in type mm [in]

## F10M Number of valves P M J Pilot specifications (Base piping type)

With manifold outlet port dual use fitting block  
D-sub connector 25-pin specifications

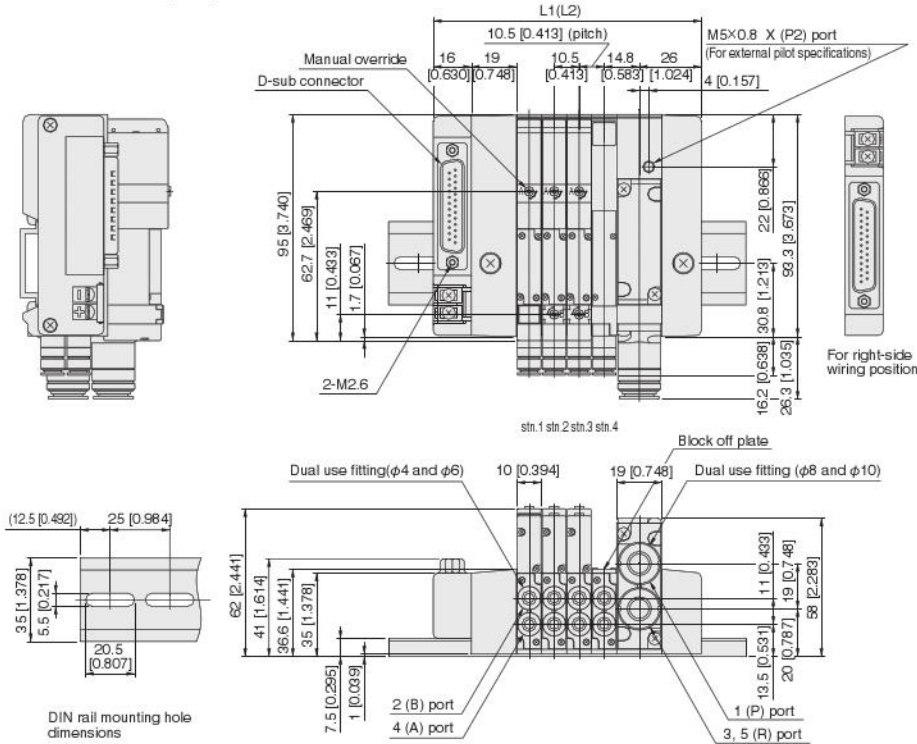

### Unit dimensions

Number of units	L1	Length of DIN rail	L2 <small>Note</small>	Length of DIN rail <small>Note</small>
2	91.5 [3.602]	125 [4.921]	110.5 [4.350]	150 [5.906]
3	102.0 [4.016]	150 [5.906]	121.0 [4.764]	175 [6.890]
4	112.5 [4.429]	150 [5.906]	131.5 [5.177]	175 [6.890]
5	123.0 [4.843]	175 [6.890]	142.0 [5.591]	175 [6.890]
6	133.5 [5.256]	175 [6.890]	152.5 [6.004]	200 [7.874]
7	144.0 [5.669]	200 [7.874]	163.0 [6.417]	200 [7.874]
8	154.5 [6.083]	200 [7.874]	173.5 [6.831]	225 [8.858]
9	165.0 [6.496]	200 [7.874]	184.0 [7.244]	225 [8.858]
10	175.5 [6.909]	225 [8.858]	194.5 [7.657]	250 [9.843]
11	186.0 [7.323]	225 [8.858]	205.0 [8.071]	250 [9.843]
12	196.5 [7.736]	250 [9.843]	215.5 [8.484]	250 [9.843]
13	207.0 [8.150]	250 [9.843]	226.0 [8.898]	275 [10.827]
14	217.5 [8.563]	275 [10.827]	236.5 [9.311]	275 [10.827]
15	228.0 [8.976]	275 [10.827]	247.0 [9.724]	300 [11.811]
16	238.5 [9.390]	275 [10.827]	257.5 [10.138]	300 [11.811]
17	249.0 [9.803]	300 [11.811]	268.0 [10.551]	325 [12.795]
18	259.5 [10.217]	300 [11.811]	278.5 [10.965]	325 [12.795]
19	270.0 [10.630]	325 [12.795]	289.0 [11.378]	325 [12.795]
20	280.5 [11.043]	325 [12.795]	299.5 [11.791]	350 [13.780]

Note: When two piping blocks are used.  
\*For right-side mounting wiring (-R), add 5.5 mm [0.217 in] to the L1 (L2) dimension.

## F10M Number of valves P M J Pilot specifications (Base piping type)

With manifold outlet port dual use fitting block  
Terminal block type

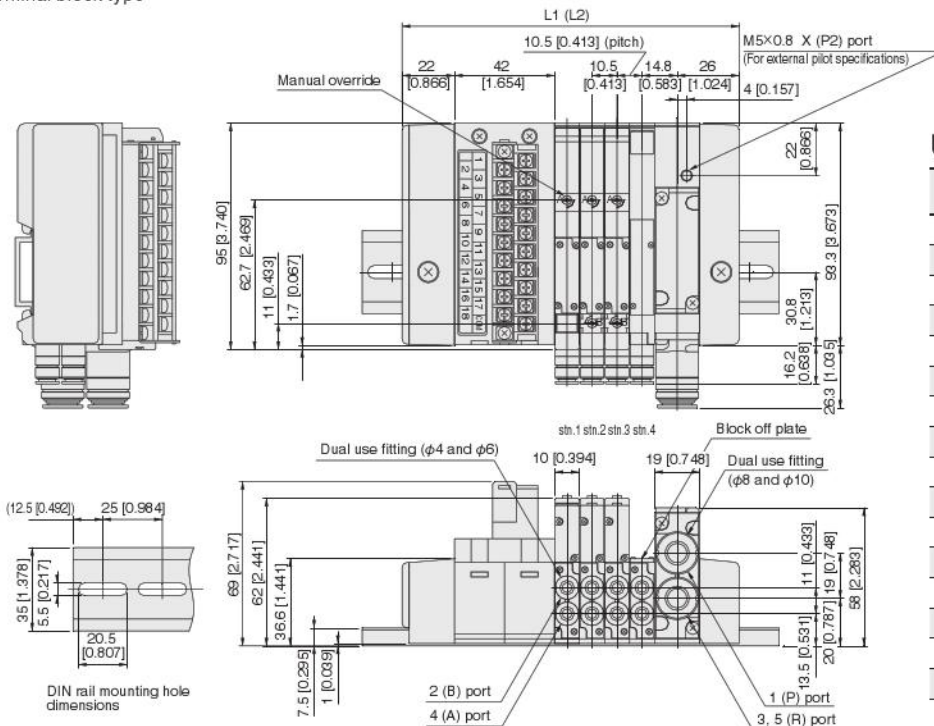

### Unit dimensions

Number of units	L1	Length of DIN rail	L2 <small>Note</small>	Length of DIN rail <small>Note</small>
2	120.5 [4.744]	150 [5.906]	139.5 [5.492]	175 [6.890]
3	131.0 [5.157]	175 [6.890]	150.0 [5.906]	175 [6.890]
4	141.5 [5.571]	175 [6.890]	160.5 [6.319]	200 [7.874]
5	152.0 [5.984]	200 [7.874]	171.0 [6.732]	200 [7.874]
6	162.5 [6.398]	200 [7.874]	181.5 [7.146]	225 [8.858]
7	173.0 [6.811]	200 [7.874]	192.0 [7.559]	225 [8.858]
8	183.5 [7.224]	225 [8.858]	202.5 [7.972]	250 [9.843]
9	194.0 [7.638]	225 [8.858]	213.0 [8.386]	250 [9.843]
10	204.5 [8.051]	250 [9.843]	223.5 [8.799]	250 [9.843]
11	215.0 [8.465]	250 [9.843]	234.0 [9.213]	275 [10.827]
12	225.5 [8.878]	275 [10.827]	244.5 [9.626]	275 [10.827]
13	236.0 [9.291]	275 [10.827]	255.0 [10.039]	300 [11.811]
14	246.5 [9.705]	275 [10.827]	265.5 [10.453]	300 [11.811]
15	257.0 [10.118]	300 [11.811]	276.0 [10.866]	325 [12.795]
16	267.5 [10.531]	300 [11.811]	286.5 [11.280]	325 [12.795]
17	278.0 [10.945]	325 [12.795]	297.0 [11.693]	325 [12.795]
18	288.5 [11.358]	325 [12.795]	307.5 [12.106]	350 [13.780]

Note: When two piping blocks are used.

# Dimensions of F10 series split manifold plug-in type mm [in]

## F10M Number of valves PHL Pilot specifications (Base piping type)

With manifold outlet port female thread block  
Flat cable connector 10-pin specifications

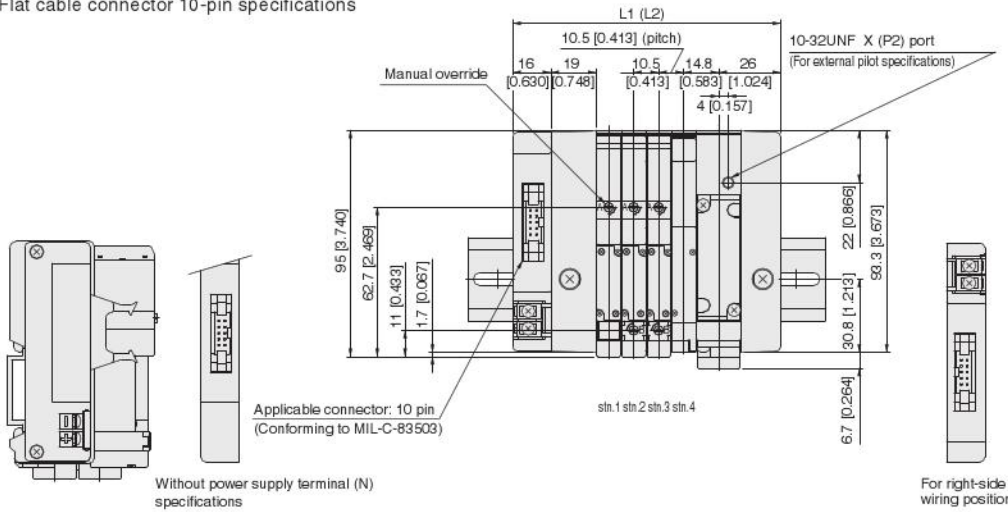

### Unit dimensions

Number of units	L1	Length of DIN rail	L2 <small>Note</small>	Length of DIN rail <small>Note</small>
2	91.5 [3.602]	125 [4.921]	110.5 [4.350]	150 [5.906]
3	102.0 [4.016]	150 [5.906]	121.0 [4.764]	175 [6.890]
4	112.5 [4.429]	150 [5.906]	131.5 [5.177]	175 [6.890]
5	123.0 [4.843]	175 [6.890]	142.0 [5.591]	175 [6.890]
6	133.5 [5.256]	175 [6.890]	152.5 [6.004]	200 [7.874]
7	144.0 [5.669]	200 [7.874]	163.0 [6.417]	200 [7.874]
8	154.5 [6.083]	200 [7.874]	173.5 [6.831]	225 [8.858]

Note: When two piping blocks are used.  
\*For right-side mounting wiring (-R), add 5.5 mm [0.217 in] to the L1 (L2) dimension.

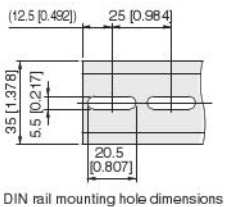

DIN rail mounting hole dimensions

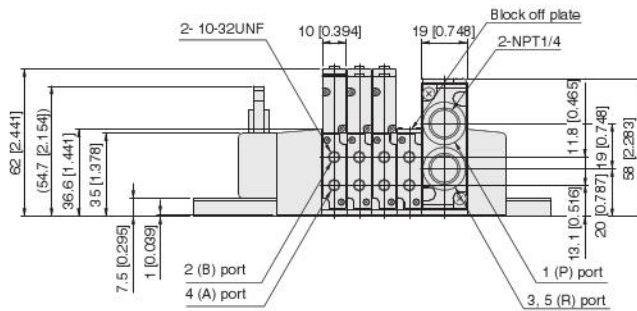

## F10M Number of valves Pilot specifications (Direct piping type)

With valve outlet port female thread block  
Flat cable connector 10-pin specifications

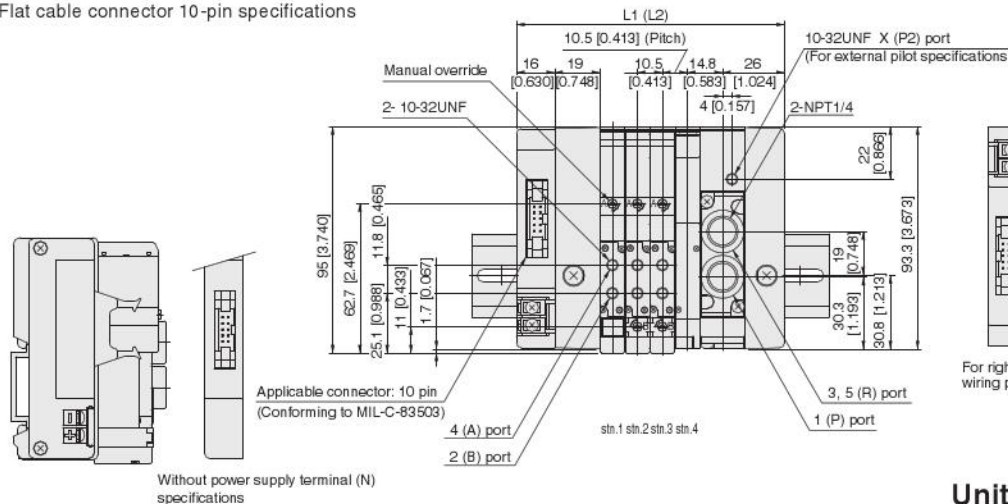

### Unit dimensions

Number of units	L1	Length of DIN rail	L2 <small>Note</small>	Length of DIN rail <small>Note</small>
2	91.5 [3.602]	125 [4.921]	110.5 [4.350]	150 [5.906]
3	102.0 [4.016]	150 [5.906]	121.0 [4.764]	175 [6.890]
4	112.5 [4.429]	150 [5.906]	131.5 [5.177]	175 [6.890]
5	123.0 [4.843]	175 [6.890]	142.0 [5.591]	175 [6.890]
6	133.5 [5.256]	175 [6.890]	152.5 [6.004]	200 [7.874]
7	144.0 [5.669]	200 [7.874]	163.0 [6.417]	200 [7.874]
8	154.5 [6.083]	200 [7.874]	173.5 [6.831]	225 [8.858]

Note: When two piping blocks are used.  
\*For right-side mounting wiring (-R), add 5.5 mm [0.217 in] to the L1 (L2) dimension.

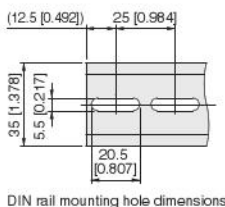

DIN rail mounting hole dimensions

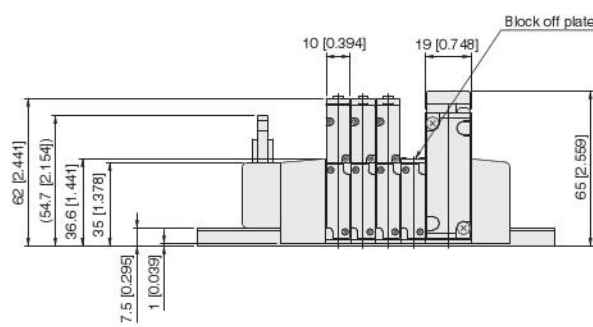

# Dimensions of F10 series split manifold plug-in type mm [in]

## F10M Number of valves PHL Pilot specifications (Base piping type)

With manifold outlet port female thread block  
Flat cable connector 20-pin specifications (side surface wiring)

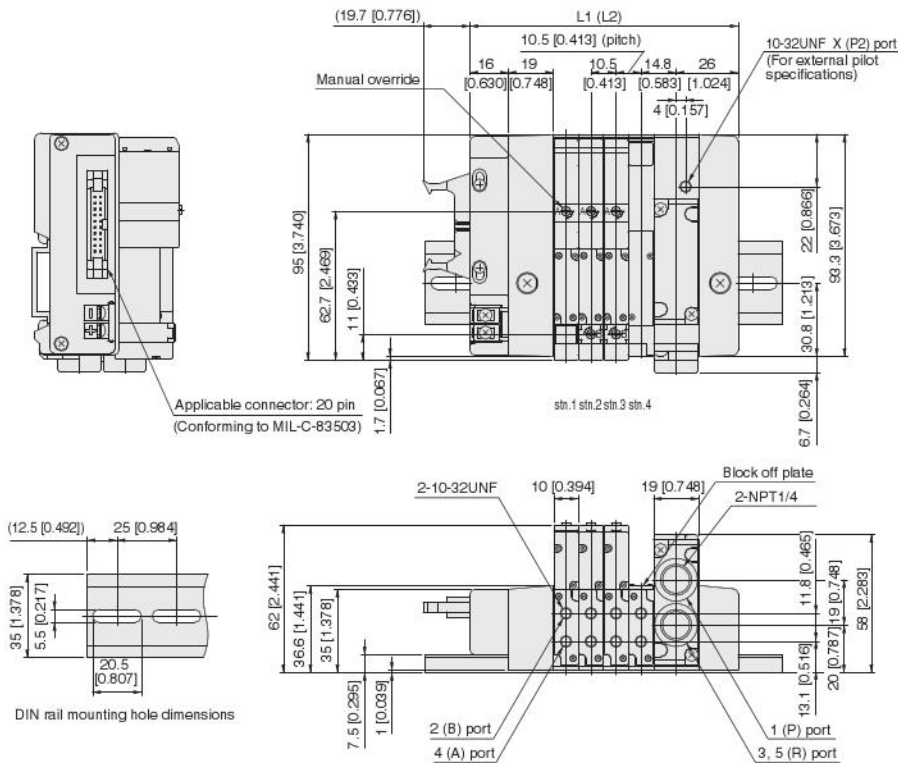

### Unit dimensions

Number of units	L1	Length of DIN rail	L2 <small>Note</small>	Length of DIN rail <small>Note</small>
2	91.5 [3.602]	125 [4.921]	110.5 [4.350]	150 [5.906]
3	102.0 [4.016]	150 [5.906]	121.0 [4.764]	175 [6.890]
4	112.5 [4.429]	150 [5.906]	131.5 [5.177]	175 [6.890]
5	123.0 [4.843]	175 [6.890]	142.0 [5.591]	175 [6.890]
6	133.5 [5.256]	175 [6.890]	152.5 [6.004]	200 [7.874]
7	144.0 [5.669]	200 [7.874]	163.0 [6.417]	200 [7.874]
8	154.5 [6.083]	200 [7.874]	173.5 [6.831]	225 [8.858]
9	165.0 [6.496]	200 [7.874]	184.0 [7.244]	225 [8.858]
10	175.5 [6.909]	225 [8.858]	194.5 [7.657]	250 [9.843]
11	186.0 [7.323]	225 [8.858]	205.0 [8.071]	250 [9.843]
12	196.5 [7.736]	250 [9.843]	215.5 [8.484]	250 [9.843]
13	207.0 [8.150]	250 [9.843]	226.0 [8.898]	275 [10.827]
14	217.5 [8.563]	275 [10.827]	236.5 [9.311]	275 [10.827]
15	228.0 [8.976]	275 [10.827]	247.0 [9.724]	300 [11.811]
16	238.5 [9.390]	275 [10.827]	257.5 [10.138]	300 [11.811]

Note: When two piping blocks are used.  
\* For right-side mounting wiring (-R), add 5.5 mm [0.217 in] to the L1 (L2) dimension.

## F10M Number of valves PH Pilot specifications (Direct piping type)

With valve outlet port female thread block  
Flat cable connector 20-pin specifications

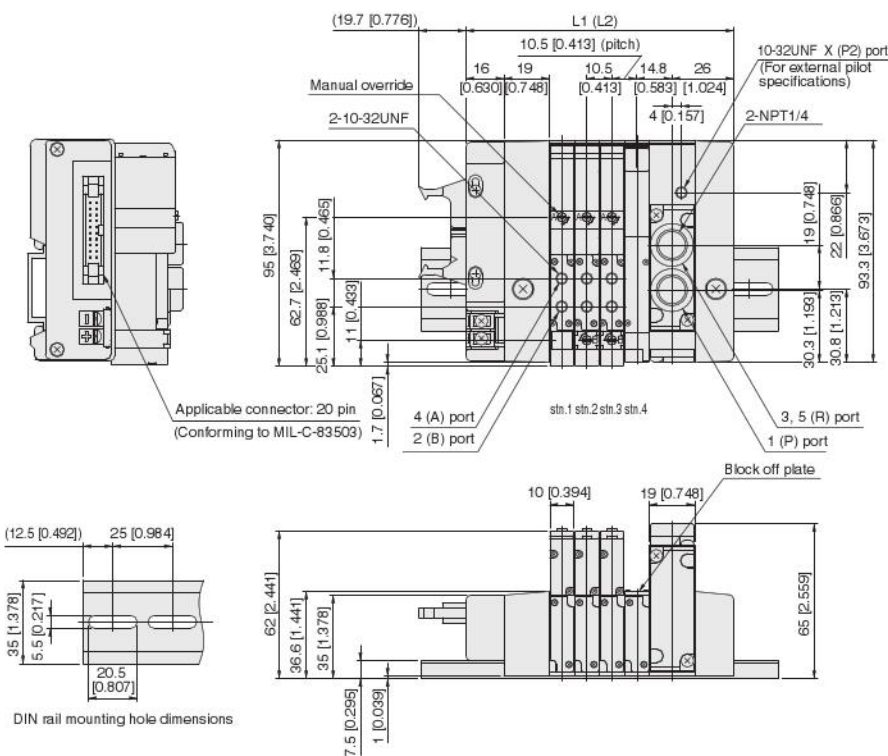

### Unit dimensions

Number of units	L1	Length of DIN rail	L2 <small>Note</small>	Length of DIN rail <small>Note</small>
2	91.5 [3.602]	125 [4.921]	110.5 [4.350]	150 [5.906]
3	102.0 [4.016]	150 [5.906]	121.0 [4.764]	175 [6.890]
4	112.5 [4.429]	150 [5.906]	131.5 [5.177]	175 [6.890]
5	123.0 [4.843]	175 [6.890]	142.0 [5.591]	175 [6.890]
6	133.5 [5.256]	175 [6.890]	152.5 [6.004]	200 [7.874]
7	144.0 [5.669]	200 [7.874]	163.0 [6.417]	200 [7.874]
8	154.5 [6.083]	200 [7.874]	173.5 [6.831]	225 [8.858]
9	165.0 [6.496]	200 [7.874]	184.0 [7.244]	225 [8.858]
10	175.5 [6.909]	225 [8.858]	194.5 [7.657]	250 [9.843]
11	186.0 [7.323]	225 [8.858]	205.0 [8.071]	250 [9.843]
12	196.5 [7.736]	250 [9.843]	215.5 [8.484]	250 [9.843]
13	207.0 [8.150]	250 [9.843]	226.0 [8.898]	275 [10.827]
14	217.5 [8.563]	275 [10.827]	236.5 [9.311]	275 [10.827]
15	228.0 [8.976]	275 [10.827]	247.0 [9.724]	300 [11.811]
16	238.5 [9.390]	275 [10.827]	257.5 [10.138]	300 [11.811]

Note: When two piping blocks are used.  
\* For right-side mounting wiring (-R), add 5.5 mm [0.217 in] to the L1 (L2) dimension.

Dimensions of F10 series split manifold plug-in type mm [in]

**F10M** [Number of valves] **PHL** [Pilot specifications] (Base piping type)

With manifold outlet port female thread block  
Flat cable connector 26-pin specifications

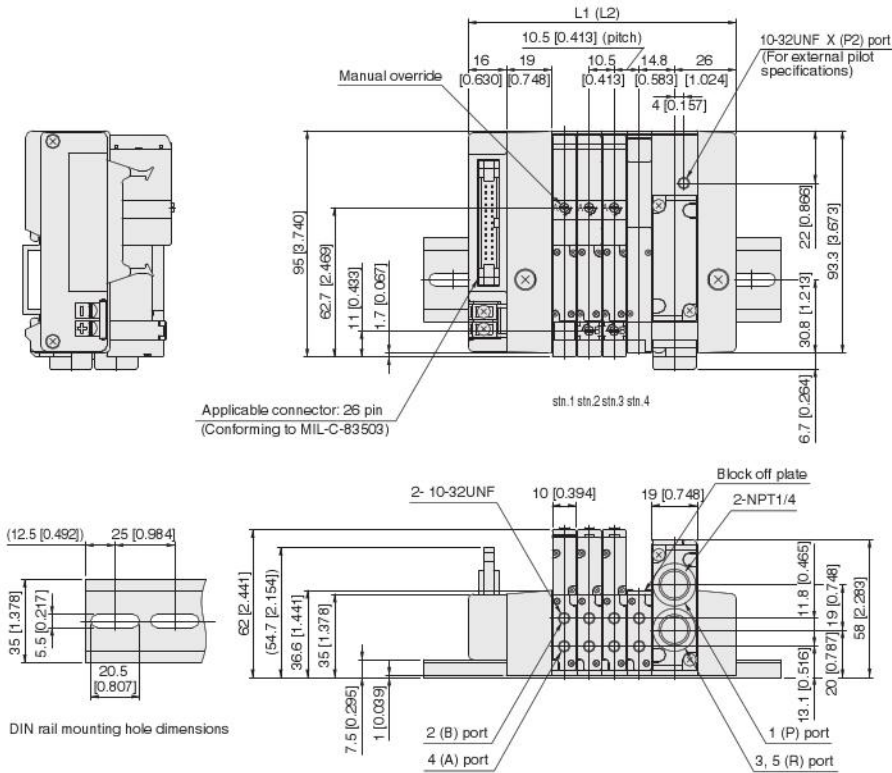

Unit dimensions

Number of units	L1	Length of DIN rail	L2 <small>Note</small>	Length of DIN rail <small>Note</small>
2	91.5 [3.602]	125 [4.921]	110.5 [4.350]	150 [5.906]
3	102.0 [4.016]	150 [5.906]	121.0 [4.764]	175 [6.890]
4	112.5 [4.429]	150 [5.906]	131.5 [5.177]	175 [6.890]
5	123.0 [4.843]	175 [6.890]	142.0 [5.591]	175 [6.890]
6	133.5 [5.256]	175 [6.890]	152.5 [6.004]	200 [7.874]
7	144.0 [5.669]	200 [7.874]	163.0 [6.417]	200 [7.874]
8	154.5 [6.083]	200 [7.874]	173.5 [6.831]	225 [8.858]
9	165.0 [6.496]	200 [7.874]	184.0 [7.244]	225 [8.858]
10	175.5 [6.909]	225 [8.858]	194.5 [7.657]	250 [9.843]
11	186.0 [7.323]	225 [8.858]	205.0 [8.071]	250 [9.843]
12	196.5 [7.736]	250 [9.843]	215.5 [8.484]	250 [9.843]
13	207.0 [8.150]	250 [9.843]	226.0 [8.898]	275 [10.827]
14	217.5 [8.563]	275 [10.827]	236.5 [9.311]	275 [10.827]
15	228.0 [8.976]	275 [10.827]	247.0 [9.724]	300 [11.811]
16	238.5 [9.390]	275 [10.827]	257.5 [10.138]	300 [11.811]
17	249.0 [9.803]	300 [11.811]	268.0 [10.551]	325 [12.795]
18	259.5 [10.217]	300 [11.811]	278.5 [10.965]	325 [12.795]
19	270.0 [10.630]	325 [12.795]	289.0 [11.378]	325 [12.795]
20	280.5 [11.043]	325 [12.795]	299.5 [11.791]	350 [13.780]

Note: When two piping blocks are used.  
\*For right-side mounting wiring (-R), add 5.5 mm [0.217 in] to the L1 (L2) dimension.

**F10M** [Number of valves] **PH** [Pilot specifications] (Direct piping type)

With valve outlet port female thread block  
Flat cable connector 26-pin specifications

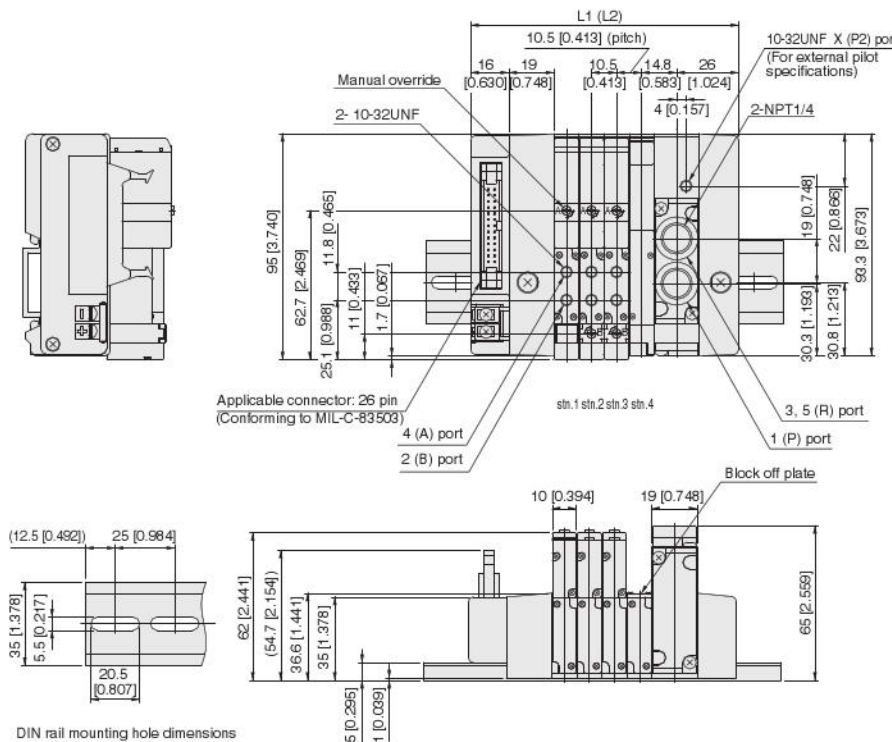

Unit dimensions

Number of units	L1	Length of DIN rail	L2 <small>Note</small>	Length of DIN rail <small>Note</small>
2	91.5 [3.602]	125 [4.921]	110.5 [4.350]	150 [5.906]
3	102.0 [4.016]	150 [5.906]	121.0 [4.764]	175 [6.890]
4	112.5 [4.429]	150 [5.906]	131.5 [5.177]	175 [6.890]
5	123.0 [4.843]	175 [6.890]	142.0 [5.591]	175 [6.890]
6	133.5 [5.256]	175 [6.890]	152.5 [6.004]	200 [7.874]
7	144.0 [5.669]	200 [7.874]	163.0 [6.417]	200 [7.874]
8	154.5 [6.083]	200 [7.874]	173.5 [6.831]	225 [8.858]
9	165.0 [6.496]	200 [7.874]	184.0 [7.244]	225 [8.858]
10	175.5 [6.909]	225 [8.858]	194.5 [7.657]	250 [9.843]
11	186.0 [7.323]	225 [8.858]	205.0 [8.071]	250 [9.843]
12	196.5 [7.736]	250 [9.843]	215.5 [8.484]	250 [9.843]
13	207.0 [8.150]	250 [9.843]	226.0 [8.898]	275 [10.827]
14	217.5 [8.563]	275 [10.827]	236.5 [9.311]	275 [10.827]
15	228.0 [8.976]	275 [10.827]	247.0 [9.724]	300 [11.811]
16	238.5 [9.390]	275 [10.827]	257.5 [10.138]	300 [11.811]
17	249.0 [9.803]	300 [11.811]	268.0 [10.551]	325 [12.795]
18	259.5 [10.217]	300 [11.811]	278.5 [10.965]	325 [12.795]
19	270.0 [10.630]	325 [12.795]	289.0 [11.378]	325 [12.795]
20	280.5 [11.043]	325 [12.795]	299.5 [11.791]	350 [13.780]

Note: When two piping blocks are used.  
\*For right-side mounting wiring (-R), add 5.5 mm [0.217 in] to the L1 (L2) dimension.

Dimensions of F10 series split manifold plug-in type mm [in]

**F10M** [Number of valves] **PHL** [Pilot specifications] (Base piping type)

With manifold outlet port female thread block  
D-sub connector 25-pin specifications

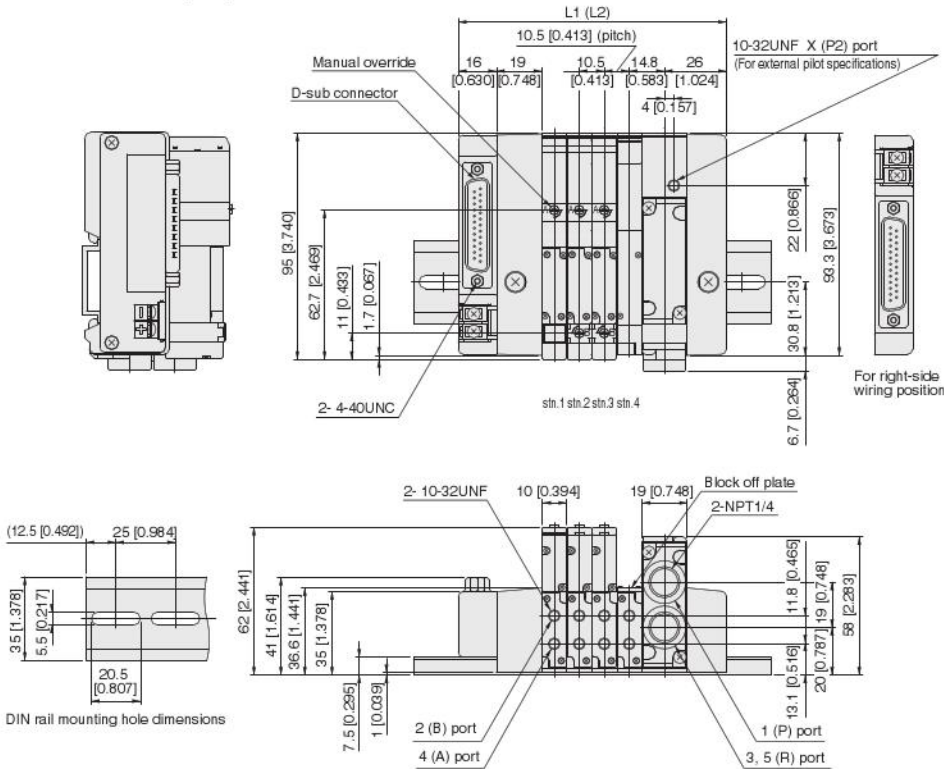

**Unit dimensions**

Number of units	L1	Length of DIN rail	L2 <small>Note</small>	Length of DIN rail <small>Note</small>
2	91.5 [3.602]	125 [4.921]	110.5 [4.350]	150 [5.906]
3	102.0 [4.016]	150 [5.906]	121.0 [4.764]	175 [6.890]
4	112.5 [4.429]	150 [5.906]	131.5 [5.177]	175 [6.890]
5	123.0 [4.843]	175 [6.890]	142.0 [5.591]	175 [6.890]
6	133.5 [5.256]	175 [6.890]	152.5 [6.004]	200 [7.874]
7	144.0 [5.669]	200 [7.874]	163.0 [6.417]	200 [7.874]
8	154.5 [6.083]	200 [7.874]	173.5 [6.831]	225 [8.858]
9	165.0 [6.496]	200 [7.874]	184.0 [7.244]	225 [8.858]
10	175.5 [6.909]	225 [8.858]	194.5 [7.657]	250 [9.843]
11	186.0 [7.323]	225 [8.858]	205.0 [8.071]	250 [9.843]
12	196.5 [7.736]	250 [9.843]	215.5 [8.484]	250 [9.843]
13	207.0 [8.150]	250 [9.843]	226.0 [8.898]	275 [10.827]
14	217.5 [8.563]	275 [10.827]	236.5 [9.311]	275 [10.827]
15	228.0 [8.976]	275 [10.827]	247.0 [9.724]	300 [11.811]
16	238.5 [9.390]	275 [10.827]	257.5 [10.138]	300 [11.811]
17	249.0 [9.803]	300 [11.811]	268.0 [10.551]	325 [12.795]
18	259.5 [10.217]	300 [11.811]	278.5 [10.965]	325 [12.795]
19	270.0 [10.630]	325 [12.795]	289.0 [11.378]	325 [12.795]
20	280.5 [11.043]	325 [12.795]	299.5 [11.791]	350 [13.780]

Note: When two piping blocks are used.  
\*For right-side mounting wiring (-R), add 5.5 mm [0.217 in] to the L1 (L2) dimension.

**F10M** [Number of valves] **PH** [Pilot specifications] (Direct piping type)

With valve outlet port female thread block  
D-sub connector 25-pin specifications

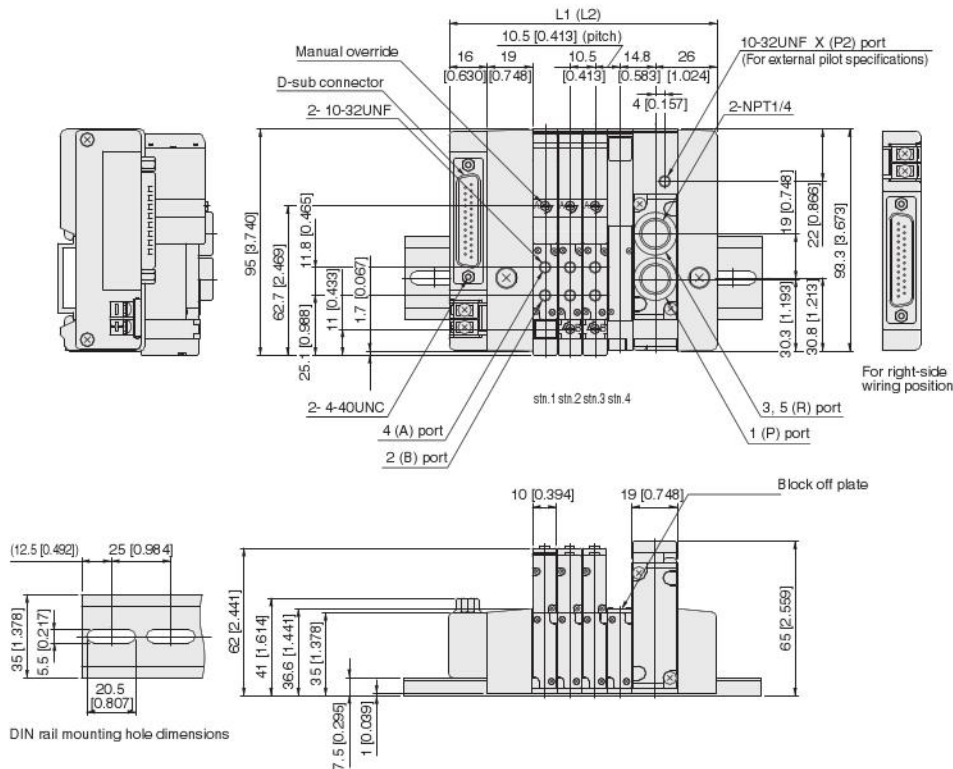

**Unit dimensions**

Number of units	L1	Length of DIN rail	L2 <small>Note</small>	Length of DIN rail <small>Note</small>
2	91.5 [3.602]	125 [4.921]	110.5 [4.350]	150 [5.906]
3	102.0 [4.016]	150 [5.906]	121.0 [4.764]	175 [6.890]
4	112.5 [4.429]	150 [5.906]	131.5 [5.177]	175 [6.890]
5	123.0 [4.843]	175 [6.890]	142.0 [5.591]	175 [6.890]
6	133.5 [5.256]	175 [6.890]	152.5 [6.004]	200 [7.874]
7	144.0 [5.669]	200 [7.874]	163.0 [6.417]	200 [7.874]
8	154.5 [6.083]	200 [7.874]	173.5 [6.831]	225 [8.858]
9	165.0 [6.496]	200 [7.874]	184.0 [7.244]	225 [8.858]
10	175.5 [6.909]	225 [8.858]	194.5 [7.657]	250 [9.843]
11	186.0 [7.323]	225 [8.858]	205.0 [8.071]	250 [9.843]
12	196.5 [7.736]	250 [9.843]	215.5 [8.484]	250 [9.843]
13	207.0 [8.150]	250 [9.843]	226.0 [8.898]	275 [10.827]
14	217.5 [8.563]	275 [10.827]	236.5 [9.311]	275 [10.827]
15	228.0 [8.976]	275 [10.827]	247.0 [9.724]	300 [11.811]
16	238.5 [9.390]	275 [10.827]	257.5 [10.138]	300 [11.811]
17	249.0 [9.803]	300 [11.811]	268.0 [10.551]	325 [12.795]
18	259.5 [10.217]	300 [11.811]	278.5 [10.965]	325 [12.795]
19	270.0 [10.630]	325 [12.795]	289.0 [11.378]	325 [12.795]
20	280.5 [11.043]	325 [12.795]	299.5 [11.791]	350 [13.780]

Note: When two piping blocks are used.  
\*For right-side mounting wiring (-R), add 5.5 mm [0.217 in] to the L1 (L2) dimension.

Dimensions of F10 series split manifold plug-in type mm [in]

**F10M** [Number of valves] **PHL** [Pilot specifications] (Base piping type)

With manifold outlet port female thread block  
D-sub connector 37-pin specifications

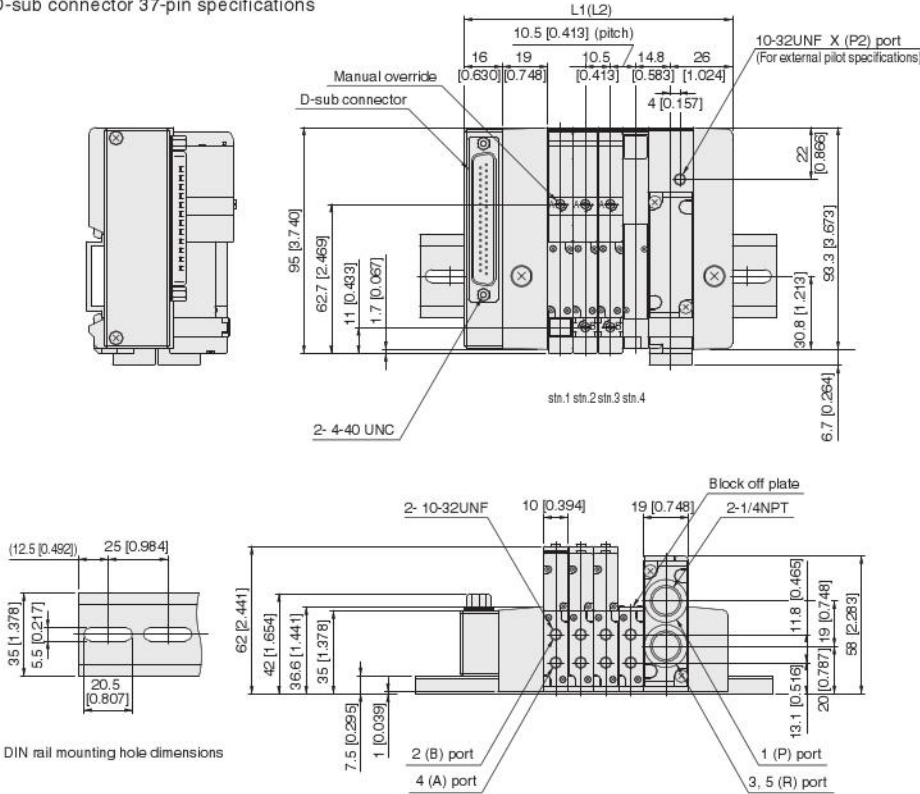

**Unit dimensions**

Number of units	L1	Length of DIN rail	L2 <small>Note</small>	Length of DIN rail <small>Note</small>
2	91.5 [3.602]	125 [4.921]	110.5 [4.350]	150 [5.906]
3	102.0 [4.016]	150 [5.906]	121.0 [4.764]	175 [6.890]
4	112.5 [4.429]	150 [5.906]	131.5 [5.177]	175 [6.890]
5	123.0 [4.843]	175 [6.890]	142.0 [5.591]	175 [6.890]
6	133.5 [5.256]	175 [6.890]	152.5 [6.004]	200 [7.874]
7	144.0 [5.669]	200 [7.874]	163.0 [6.417]	200 [7.874]
8	154.5 [6.083]	200 [7.874]	173.5 [6.831]	225 [8.858]
9	165.0 [6.496]	200 [7.874]	184.0 [7.244]	225 [8.858]
10	175.5 [6.909]	225 [8.858]	194.5 [7.657]	250 [9.843]
11	186.0 [7.323]	225 [8.858]	205.0 [8.071]	250 [9.843]
12	196.5 [7.736]	250 [9.843]	215.5 [8.484]	250 [9.843]
13	207.0 [8.150]	250 [9.843]	226.0 [8.898]	275 [10.827]
14	217.5 [8.563]	275 [10.827]	236.5 [9.311]	275 [10.827]
15	228.0 [8.976]	275 [10.827]	247.0 [9.724]	300 [11.811]
16	238.5 [9.390]	275 [10.827]	257.5 [10.138]	300 [11.811]
17	249.0 [9.803]	300 [11.811]	268.0 [10.551]	325 [12.795]
18	259.5 [10.217]	300 [11.811]	278.5 [10.965]	325 [12.795]
19	270.0 [10.630]	325 [12.795]	289.0 [11.378]	325 [12.795]
20	280.5 [11.043]	325 [12.795]	299.5 [11.791]	350 [13.780]

Note: When two piping blocks are used.  
\*For right-side mounting wiring (-R), add 5.5 mm [0.217 in] to the L1 (L2) dimension.

**F10M** [Number of valves] **PH** [Pilot specifications] (Direct piping type)

With valve outlet port female thread block  
D-sub connector 37-pin specifications

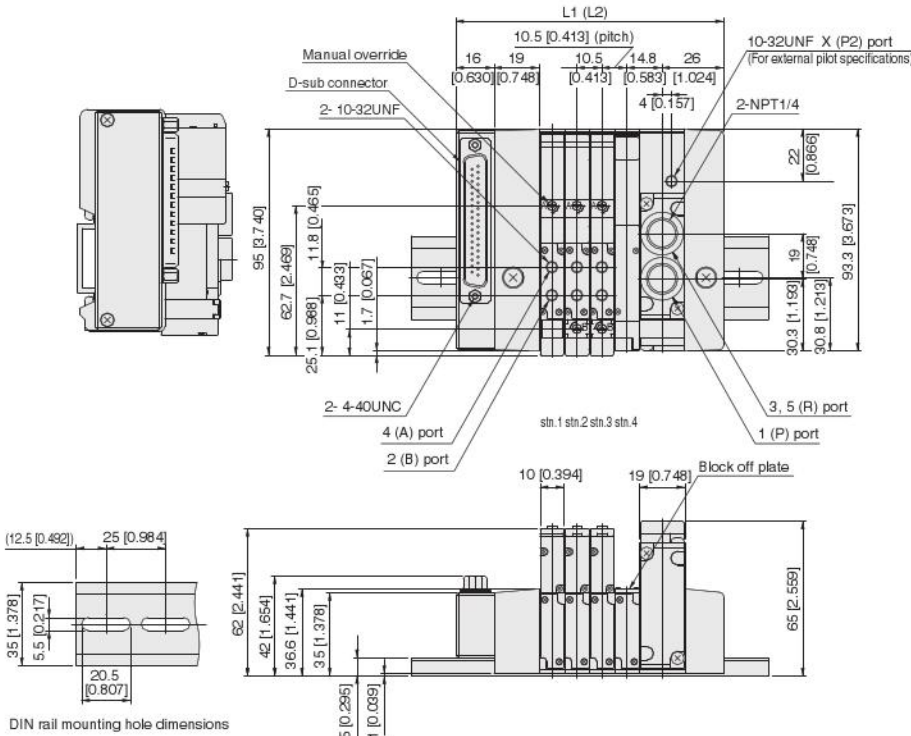

**Unit dimensions**

Number of units	L1	Length of DIN rail	L2 <small>Note</small>	Length of DIN rail <small>Note</small>
2	91.5 [3.602]	125 [4.921]	110.5 [4.350]	150 [5.906]
3	102.0 [4.016]	150 [5.906]	121.0 [4.764]	175 [6.890]
4	112.5 [4.429]	150 [5.906]	131.5 [5.177]	175 [6.890]
5	123.0 [4.843]	175 [6.890]	142.0 [5.591]	175 [6.890]
6	133.5 [5.256]	175 [6.890]	152.5 [6.004]	200 [7.874]
7	144.0 [5.669]	200 [7.874]	163.0 [6.417]	200 [7.874]
8	154.5 [6.083]	200 [7.874]	173.5 [6.831]	225 [8.858]
9	165.0 [6.496]	200 [7.874]	184.0 [7.244]	225 [8.858]
10	175.5 [6.909]	225 [8.858]	194.5 [7.657]	250 [9.843]
11	186.0 [7.323]	225 [8.858]	205.0 [8.071]	250 [9.843]
12	196.5 [7.736]	250 [9.843]	215.5 [8.484]	250 [9.843]
13	207.0 [8.150]	250 [9.843]	226.0 [8.898]	275 [10.827]
14	217.5 [8.563]	275 [10.827]	236.5 [9.311]	275 [10.827]
15	228.0 [8.976]	275 [10.827]	247.0 [9.724]	300 [11.811]
16	238.5 [9.390]	275 [10.827]	257.5 [10.138]	300 [11.811]
17	249.0 [9.803]	300 [11.811]	268.0 [10.551]	325 [12.795]
18	259.5 [10.217]	300 [11.811]	278.5 [10.965]	325 [12.795]
19	270.0 [10.630]	325 [12.795]	289.0 [11.378]	325 [12.795]
20	280.5 [11.043]	325 [12.795]	299.5 [11.791]	350 [13.780]

Note: When two piping blocks are used.  
\*For right-side mounting wiring (-R), add 5.5 mm [0.217 in] to the L1 (L2) dimension.

Dimensions of F10 series split manifold plug-in type mm [In]

**F10M** [Number of valves] **PHL** [Pilot specifications] (Base piping type)

With manifold outlet port female thread block  
Terminal block type

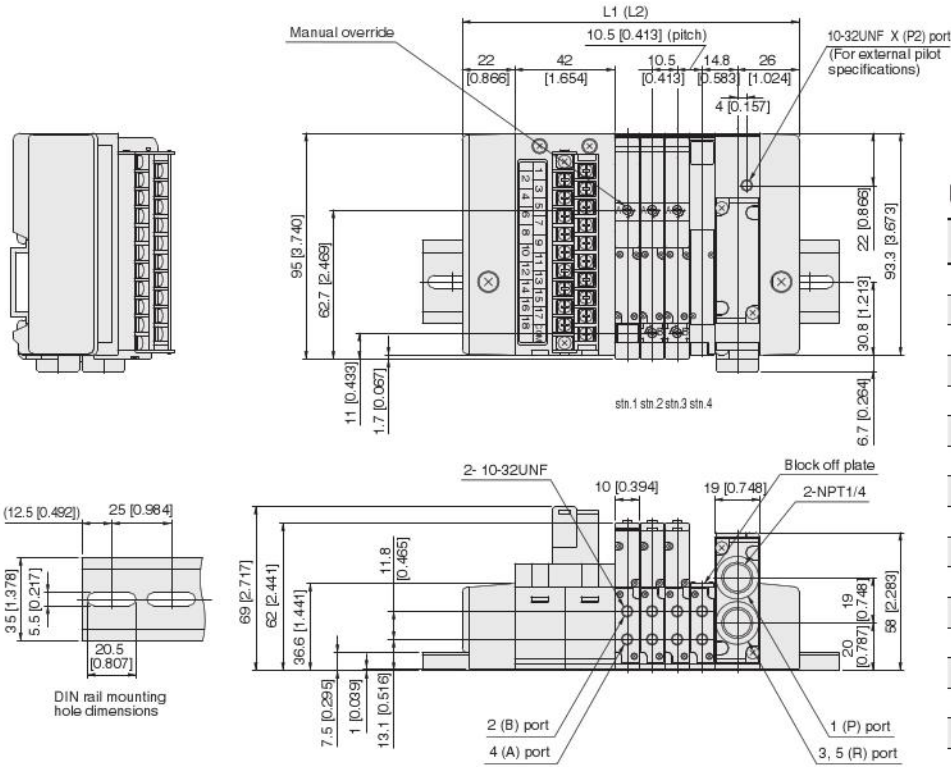

**Unit dimensions**

Number of units	L1	Length of DIN rail	L2 <small>NOTE</small>	Length of DIN rail <small>NOTE</small>
2	120.5 [4.744]	150 [5.906]	139.5 [5.492]	175 [6.890]
3	131.0 [5.157]	175 [6.890]	150.0 [5.906]	175 [6.890]
4	141.5 [5.571]	175 [6.890]	160.5 [6.319]	200 [7.874]
5	152.0 [5.984]	200 [7.874]	171.0 [6.732]	200 [7.874]
6	162.5 [6.398]	200 [7.874]	181.5 [7.146]	225 [8.858]
7	173.0 [6.811]	200 [7.874]	192.0 [7.559]	225 [8.858]
8	183.5 [7.224]	225 [8.858]	202.5 [7.972]	250 [9.843]
9	194.0 [7.638]	225 [8.858]	213.0 [8.386]	250 [9.843]
10	204.5 [8.051]	250 [9.843]	223.5 [8.799]	250 [9.843]
11	215.0 [8.465]	250 [9.843]	234.0 [9.213]	275 [10.827]
12	225.5 [8.878]	275 [10.827]	244.5 [9.626]	275 [10.827]
13	236.0 [9.291]	275 [10.827]	255.0 [10.039]	300 [11.811]
14	246.5 [9.705]	275 [10.827]	265.5 [10.453]	300 [11.811]
15	257.0 [10.118]	300 [11.811]	276.0 [10.866]	325 [12.795]
16	267.5 [10.531]	300 [11.811]	286.5 [11.280]	325 [12.795]
17	278.0 [10.945]	325 [12.795]	297.0 [11.693]	325 [12.795]
18	288.5 [11.358]	325 [12.795]	307.5 [12.106]	350 [13.780]

Note: When two piping blocks are used.

**F10M** [Number of valves] **PH** [Pilot specifications] (Direct piping type)

With valve outlet port female thread block  
Terminal block type

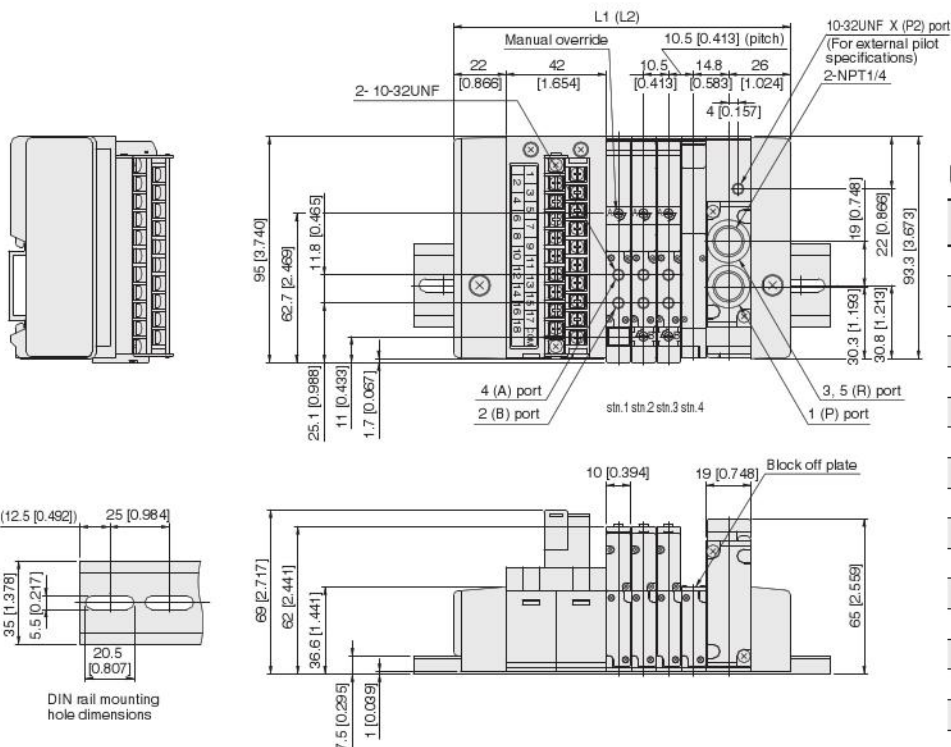

**Unit dimensions**

Number of units	L1	Length of DIN rail	L2 <small>NOTE</small>	Length of DIN rail <small>NOTE</small>
2	120.5 [4.744]	150 [5.906]	139.5 [5.492]	175 [6.890]
3	131.0 [5.157]	175 [6.890]	150.0 [5.906]	175 [6.890]
4	141.5 [5.571]	175 [6.890]	160.5 [6.319]	200 [7.874]
5	152.0 [5.984]	200 [7.874]	171.0 [6.732]	200 [7.874]
6	162.5 [6.398]	200 [7.874]	181.5 [7.146]	225 [8.858]
7	173.0 [6.811]	200 [7.874]	192.0 [7.559]	225 [8.858]
8	183.5 [7.224]	225 [8.858]	202.5 [7.972]	250 [9.843]
9	194.0 [7.638]	225 [8.858]	213.0 [8.386]	250 [9.843]
10	204.5 [8.051]	250 [9.843]	223.5 [8.799]	250 [9.843]
11	215.0 [8.465]	250 [9.843]	234.0 [9.213]	275 [10.827]
12	225.5 [8.878]	275 [10.827]	244.5 [9.626]	275 [10.827]
13	236.0 [9.291]	275 [10.827]	255.0 [10.039]	300 [11.811]
14	246.5 [9.705]	275 [10.827]	265.5 [10.453]	300 [11.811]
15	257.0 [10.118]	300 [11.811]	276.0 [10.866]	325 [12.795]
16	267.5 [10.531]	300 [11.811]	286.5 [11.280]	325 [12.795]
17	278.0 [10.945]	325 [12.795]	297.0 [11.693]	325 [12.795]
18	288.5 [11.358]	325 [12.795]	307.5 [12.106]	350 [13.780]

Note: When two piping blocks are used.

# Dimensions of F10 series serial transmission compatible manifold mm [in]

**F10M** [Number of valves] **S<sup>M</sup>L<sup>J</sup>** [Pilot specifications] (Base piping type)

With manifold outlet port dual use fitting block  
(Integrated serial transmission block compatible model)

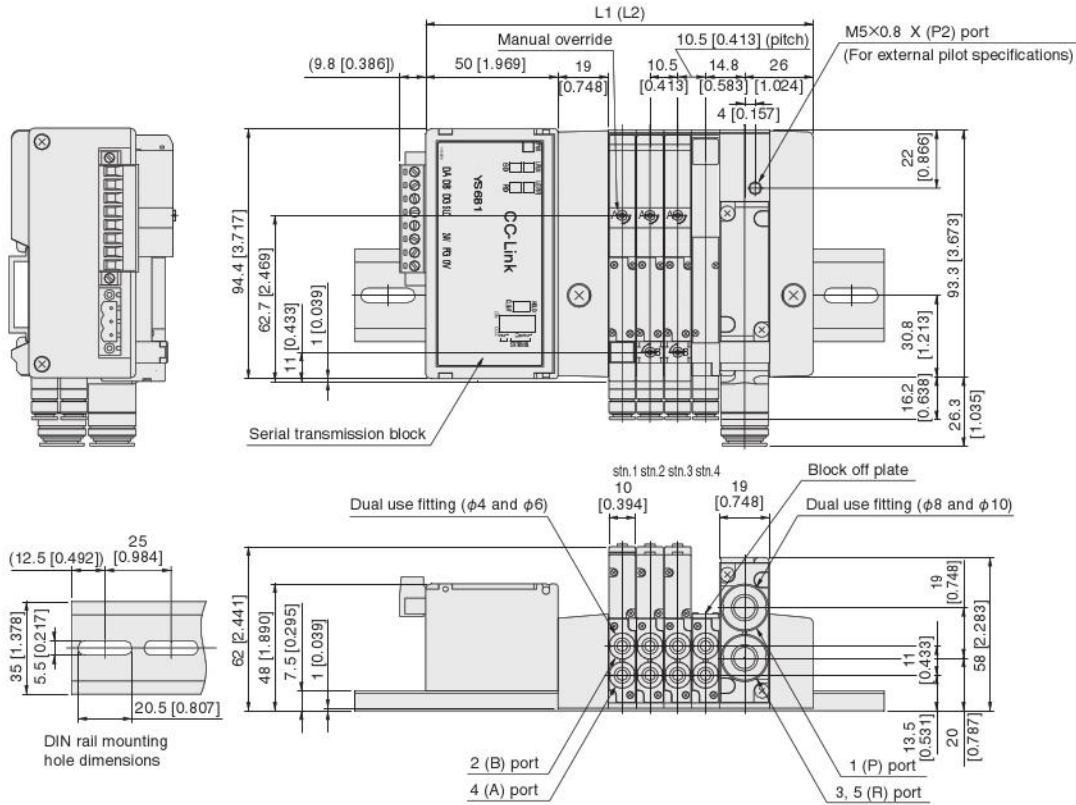

## Unit dimensions

Number of units	L1	Length of DIN rail	L2 <small>Note</small>	Length of DIN rail <small>Note</small>
2	125.5 [4.941]	175 [6.890]	144.5 [5.689]	200 [7.874]
3	136.0 [5.354]	200 [7.874]	155.0 [6.102]	200 [7.874]
4	146.5 [5.768]	200 [7.874]	165.5 [6.516]	225 [8.858]
5	157.0 [6.181]	200 [7.874]	176.0 [6.929]	225 [8.858]
6	167.5 [6.594]	225 [8.858]	186.5 [7.343]	250 [9.843]
7	178.0 [7.008]	225 [8.858]	197.0 [7.756]	250 [9.843]
8	188.5 [7.421]	250 [9.843]	207.5 [8.169]	250 [9.843]
9	199.0 [7.835]	250 [9.843]	218.0 [8.583]	275 [10.827]
10	209.5 [8.248]	250 [9.843]	228.5 [8.996]	275 [10.827]
11	220.0 [8.661]	275 [10.827]	239.0 [9.409]	300 [11.811]
12	230.5 [9.075]	275 [10.827]	249.5 [9.823]	300 [11.811]
13	241.0 [9.488]	300 [11.811]	260.0 [10.236]	300 [11.811]
14	251.5 [9.902]	300 [11.811]	270.5 [10.650]	325 [12.795]
15	262.0 [10.315]	325 [12.795]	281.0 [11.063]	325 [12.795]
16	272.5 [10.728]	325 [12.795]	291.5 [11.476]	350 [13.780]
17	283.0 [11.142]	350 [13.780]	302.0 [11.890]	375 [14.764]
18	293.5 [11.555]	350 [13.780]	312.5 [12.303]	375 [14.764]
19	304.0 [11.969]	350 [13.780]	323.0 [12.717]	375 [14.764]
20	314.5 [12.382]	375 [14.764]	333.5 [13.130]	400 [15.748]

Note: When two piping blocks are used.  
\*For right-side mounting wiring (-R), add 5.5 mm [0.217 in] to the L1 (L2) dimension.

**F10M** [Number of valves] **SHL** [Pilot specifications] (Base piping type)

With manifold outlet port female thread block  
(Integrated serial transmission block compatible manifold)

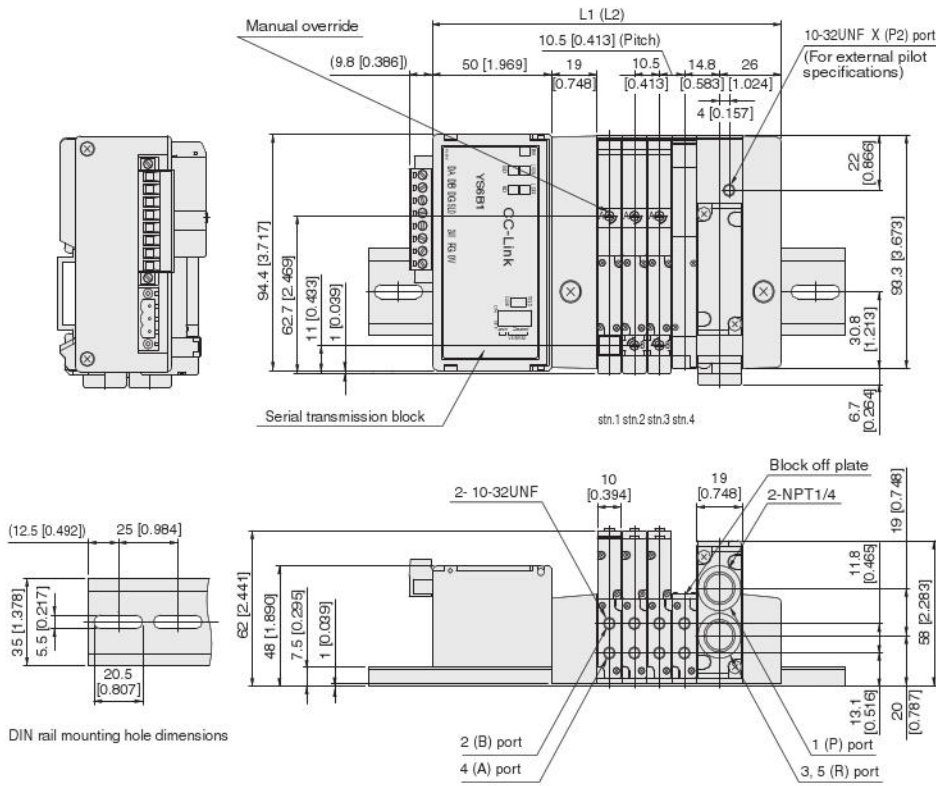

**Unit dimensions**

Number of units	L1	Length of DIN rail	L2 <small>Note</small>	Length of DIN rail <small>Note</small>
2	125.5 [4.941]	175 [6.890]	144.5 [5.689]	200 [7.874]
3	136.0 [5.354]	200 [7.874]	155.0 [6.102]	200 [7.874]
4	146.5 [5.768]	200 [7.874]	165.5 [6.516]	225 [8.858]
5	157.0 [6.181]	200 [7.874]	176.0 [6.929]	225 [8.858]
6	167.5 [6.594]	225 [8.858]	186.5 [7.343]	250 [9.843]
7	178.0 [7.008]	225 [8.858]	197.0 [7.756]	250 [9.843]
8	188.5 [7.421]	250 [9.843]	207.5 [8.169]	250 [9.843]
9	199.0 [7.835]	250 [9.843]	218.0 [8.583]	275 [10.827]
10	209.5 [8.248]	250 [9.843]	228.5 [8.996]	275 [10.827]
11	220.0 [8.661]	275 [10.827]	239.0 [9.409]	300 [11.811]
12	230.5 [9.075]	275 [10.827]	249.5 [9.823]	300 [11.811]
13	241.0 [9.488]	300 [11.811]	260.0 [10.236]	300 [11.811]
14	251.5 [9.902]	300 [11.811]	270.5 [10.650]	325 [12.795]
15	262.0 [10.315]	325 [12.795]	281.0 [11.063]	325 [12.795]
16	272.5 [10.728]	325 [12.795]	291.5 [11.476]	350 [13.780]
17	283.0 [11.142]	350 [13.780]	302.0 [11.890]	375 [14.764]
18	293.5 [11.555]	350 [13.780]	312.5 [12.303]	375 [14.764]
19	304.0 [11.969]	350 [13.780]	323.0 [12.717]	375 [14.764]
20	314.5 [12.382]	375 [14.764]	333.5 [13.130]	400 [15.748]

Note: When two piping blocks are used.  
\*For right-side mounting wiring (-R), add 5.5 mm [0.217 in] to the L1 (L2) dimension.

**F10M** [Number of valves] **SH** [Pilot specifications] (Direct piping type)

With valve outlet port female thread block  
(Integrated serial transmission block compatible manifold)

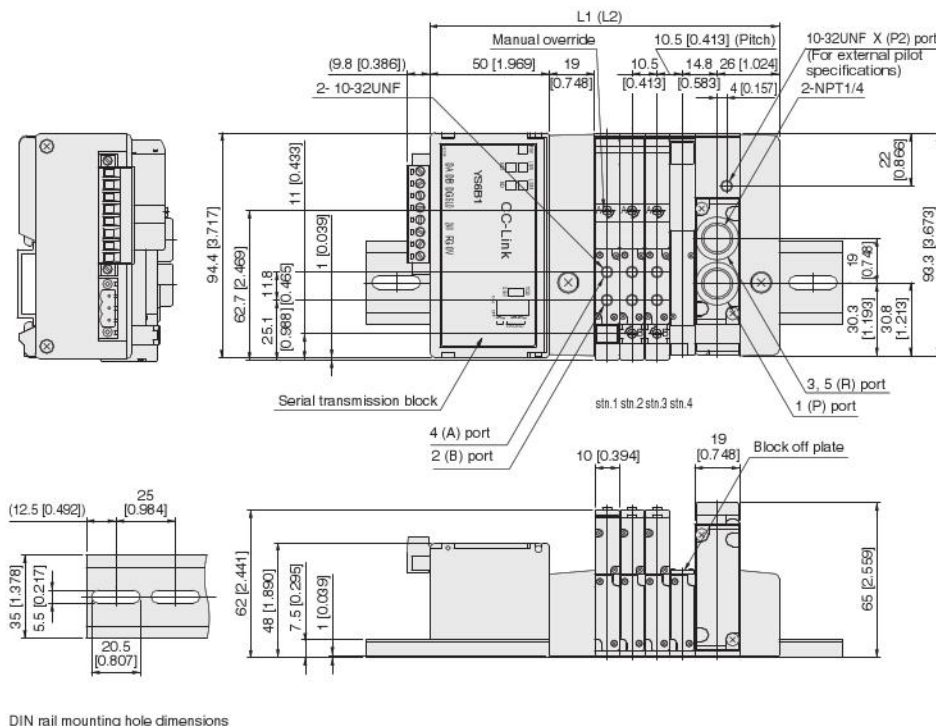

**Unit dimensions**

Number of units	L1	Length of DIN rail	L2 <small>Note</small>	Length of DIN rail <small>Note</small>
2	125.5 [4.941]	175 [6.890]	144.5 [5.689]	200 [7.874]
3	136.0 [5.354]	200 [7.874]	155.0 [6.102]	200 [7.874]
4	146.5 [5.768]	200 [7.874]	165.5 [6.516]	225 [8.858]
5	157.0 [6.181]	200 [7.874]	176.0 [6.929]	225 [8.858]
6	167.5 [6.594]	225 [8.858]	186.5 [7.343]	250 [9.843]
7	178.0 [7.008]	225 [8.858]	197.0 [7.756]	250 [9.843]
8	188.5 [7.421]	250 [9.843]	207.5 [8.169]	250 [9.843]
9	199.0 [7.835]	250 [9.843]	218.0 [8.583]	275 [10.827]
10	209.5 [8.248]	250 [9.843]	228.5 [8.996]	275 [10.827]
11	220.0 [8.661]	275 [10.827]	239.0 [9.409]	300 [11.811]
12	230.5 [9.075]	275 [10.827]	249.5 [9.823]	300 [11.811]
13	241.0 [9.488]	300 [11.811]	260.0 [10.236]	300 [11.811]
14	251.5 [9.902]	300 [11.811]	270.5 [10.650]	325 [12.795]
15	262.0 [10.315]	325 [12.795]	281.0 [11.063]	325 [12.795]
16	272.5 [10.728]	325 [12.795]	291.5 [11.476]	350 [13.780]
17	283.0 [11.142]	350 [13.780]	302.0 [11.890]	375 [14.764]
18	293.5 [11.555]	350 [13.780]	312.5 [12.303]	375 [14.764]
19	304.0 [11.969]	350 [13.780]	323.0 [12.717]	375 [14.764]
20	314.5 [12.382]	375 [14.764]	333.5 [13.130]	400 [15.748]

Note: When two piping blocks are used.  
\*For right-side mounting wiring (-R), add 5.5 mm [0.217 in] to the L1 (L2) dimension.

# Dimensions of F10 series serial transmission compatible manifold mm [In]

## F10M Number of valves S M L Pilot specifications (Base piping type)

With manifold outlet port dual use fitting block

(Stand alone serial transmission block compatible manifold)

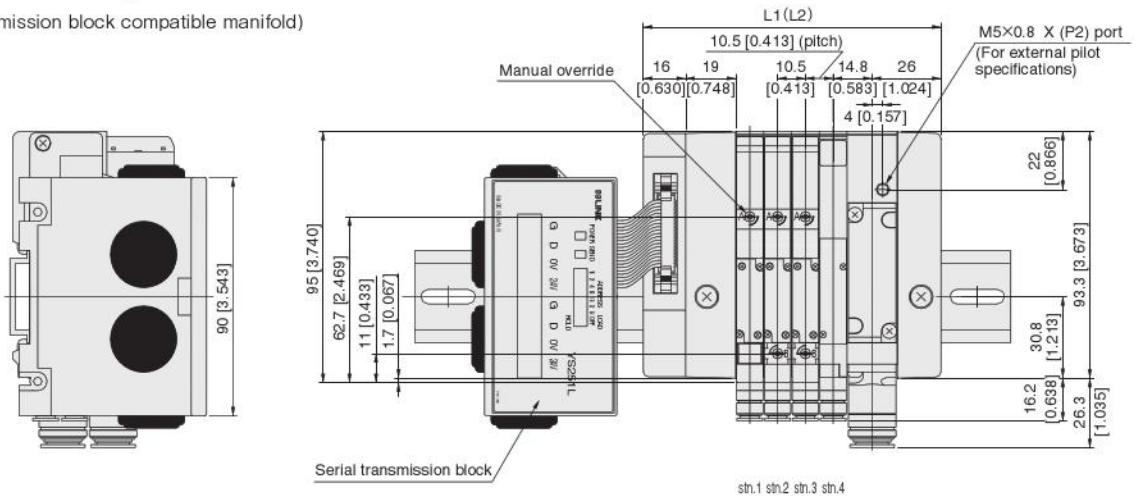

### Unit dimensions

Number of units	L1	Length of DIN rail	L2	Length of DIN rail
2	91.5 [3.602]	200 [7.874]	110.5 [4.350]	200 [7.874]
3	102.0 [4.016]	200 [7.874]	121.0 [4.764]	225 [8.858]
4	112.5 [4.429]	225 [8.858]	131.5 [5.177]	225 [8.858]
5	123.0 [4.843]	225 [8.858]	142.0 [5.591]	250 [9.843]
6	133.5 [5.256]	225 [8.858]	152.5 [6.004]	250 [9.843]
7	144.0 [5.669]	250 [9.843]	163.0 [6.417]	275 [10.827]
8	154.5 [6.083]	250 [9.843]	173.5 [6.831]	275 [10.827]
9	165.0 [6.496]	275 [10.827]	184.0 [7.244]	275 [10.827]
10	175.5 [6.909]	275 [10.827]	194.5 [7.657]	300 [11.811]
11	186.0 [7.323]	300 [11.811]	205.0 [8.071]	300 [11.811]
12	196.5 [7.736]	300 [11.811]	215.5 [8.484]	325 [12.795]
13	207.0 [8.150]	300 [11.811]	226.0 [8.898]	325 [12.795]
14	217.5 [8.563]	325 [12.795]	236.5 [9.311]	350 [13.780]
15	228.0 [8.976]	325 [12.795]	247.0 [9.724]	350 [13.780]
16	238.5 [9.390]	350 [13.780]	257.5 [10.138]	350 [13.780]

Note: When two piping blocks are used.

\*For right-side mounting wiring (-R), add 5.5 mm [0.217 in] to the L1 (L2) dimension.

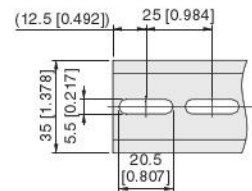
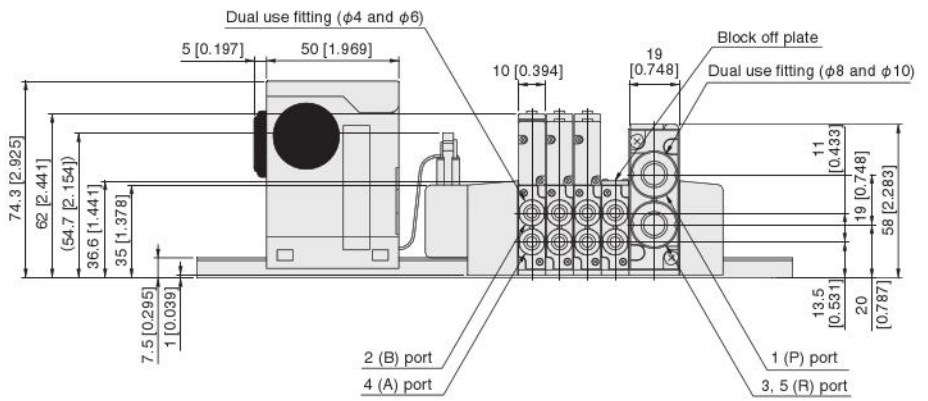

DIN rail mounting hole dimensions

### Additional Parts (available separately)

- Muffler: **KM-J10** for both plug-in and non-plug-in

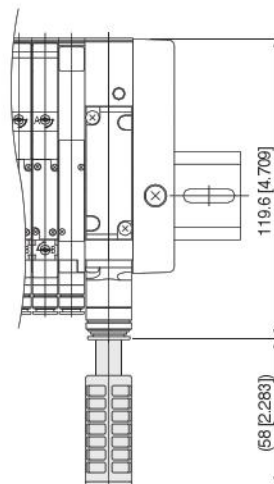
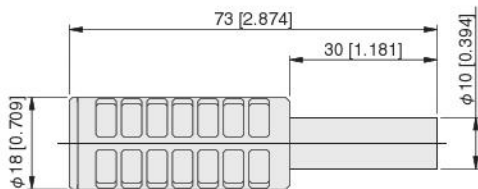

**F10M** [Number of valves] **SHL** [Pilot specifications] (Base piping type)

With manifold outlet port female thread block  
(Stand alone serial transmission block compatible manifold)

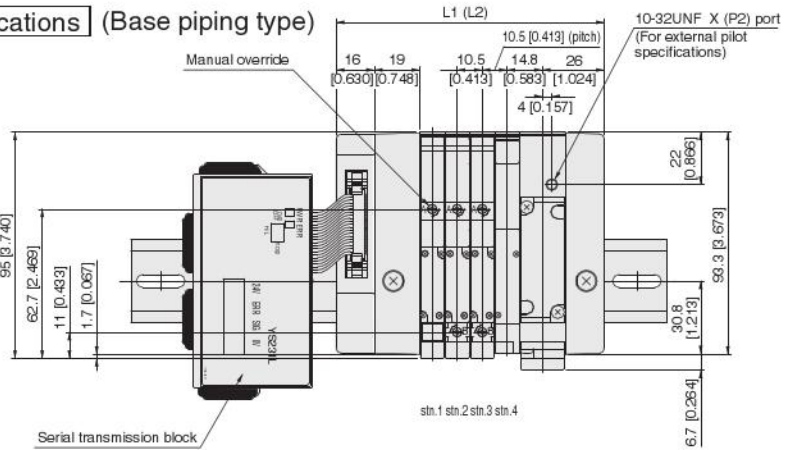
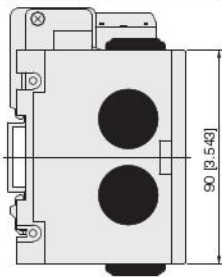

**Unit dimensions**

Number of units	L1	Length of DIN rail	L2 <small>Note</small>	Length of DIN rail <small>Note</small>
2	91.5 [3.602]	200 [7.874]	110.5 [4.350]	200 [7.874]
3	102.0 [4.016]	200 [7.874]	121.0 [4.764]	225 [8.858]
4	112.5 [4.429]	225 [8.858]	131.5 [5.177]	225 [8.858]
5	123.0 [4.843]	225 [8.858]	142.0 [5.591]	250 [9.843]
6	133.5 [5.256]	225 [8.858]	152.5 [6.004]	250 [9.843]
7	144.0 [5.669]	250 [9.843]	163.0 [6.417]	275 [10.827]
8	154.5 [6.083]	250 [9.843]	173.5 [6.831]	275 [10.827]
9	165.0 [6.496]	275 [10.827]	184.0 [7.244]	275 [10.827]
10	175.5 [6.909]	275 [10.827]	194.5 [7.657]	300 [11.811]
11	186.0 [7.323]	300 [11.811]	205.0 [8.071]	300 [11.811]
12	196.5 [7.736]	300 [11.811]	215.5 [8.484]	325 [12.795]
13	207.0 [8.150]	300 [11.811]	226.0 [8.898]	325 [12.795]
14	217.5 [8.563]	325 [12.795]	236.5 [9.311]	350 [13.780]
15	228.0 [8.976]	325 [12.795]	247.0 [9.724]	350 [13.780]
16	238.5 [9.390]	350 [13.780]	257.5 [10.138]	350 [13.780]

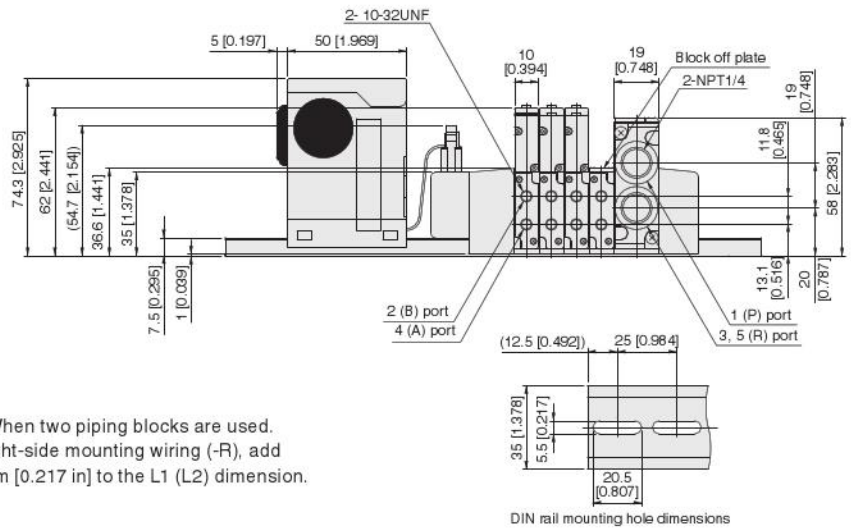

Note: When two piping blocks are used.  
\* For right-side mounting wiring (-R), add 5.5 mm [0.217 in] to the L1 (L2) dimension.

**F10M** [Number of valves] **SH** [Pilot specifications] (Direct piping type)

With valve outlet port female thread block  
(Stand alone serial transmission block compatible manifold)

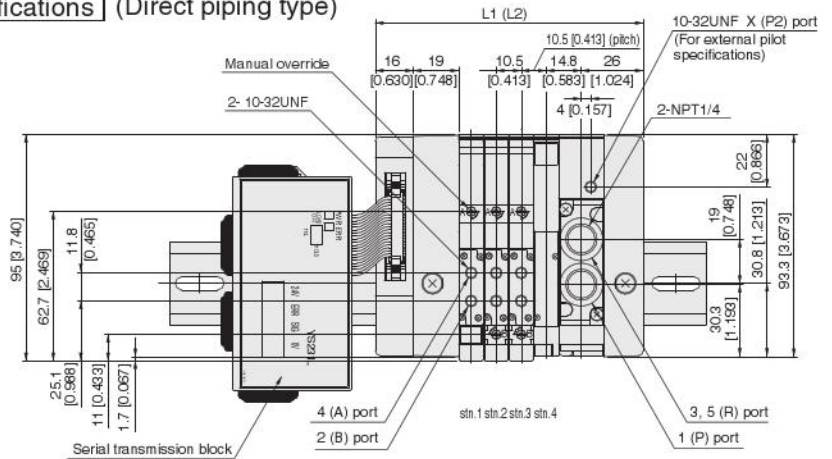
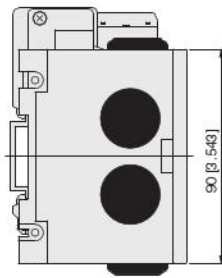

**Unit dimensions**

Number of units	L1	Length of DIN rail	L2 <small>Note</small>	Length of DIN rail <small>Note</small>
2	91.5 [3.602]	200 [7.874]	110.5 [4.350]	200 [7.874]
3	102.0 [4.016]	200 [7.874]	121.0 [4.764]	225 [8.858]
4	112.5 [4.429]	225 [8.858]	131.5 [5.177]	225 [8.858]
5	123.0 [4.843]	225 [8.858]	142.0 [5.591]	250 [9.843]
6	133.5 [5.256]	225 [8.858]	152.5 [6.004]	250 [9.843]
7	144.0 [5.669]	250 [9.843]	163.0 [6.417]	275 [10.827]
8	154.5 [6.083]	250 [9.843]	173.5 [6.831]	275 [10.827]
9	165.0 [6.496]	275 [10.827]	184.0 [7.244]	275 [10.827]
10	175.5 [6.909]	275 [10.827]	194.5 [7.657]	300 [11.811]
11	186.0 [7.323]	300 [11.811]	205.0 [8.071]	300 [11.811]
12	196.5 [7.736]	300 [11.811]	215.5 [8.484]	325 [12.795]
13	207.0 [8.150]	300 [11.811]	226.0 [8.898]	325 [12.795]
14	217.5 [8.563]	325 [12.795]	236.5 [9.311]	350 [13.780]
15	228.0 [8.976]	325 [12.795]	247.0 [9.724]	350 [13.780]
16	238.5 [9.390]	350 [13.780]	257.5 [10.138]	350 [13.780]

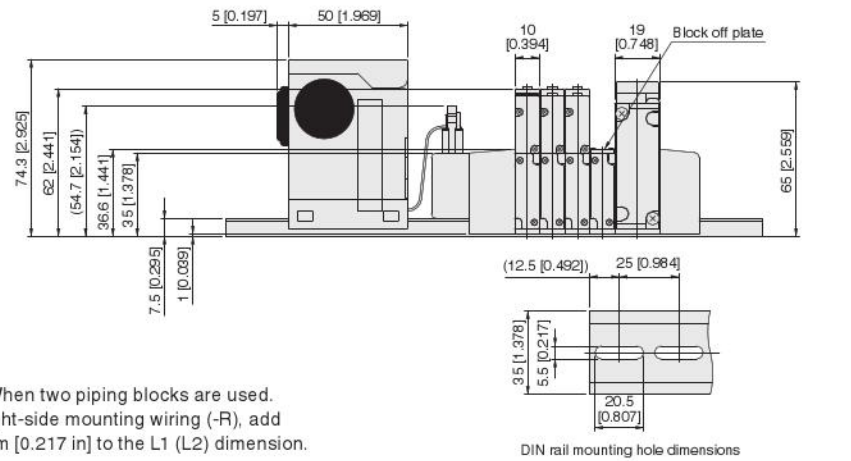

Note: When two piping blocks are used.  
\* For right-side mounting wiring (-R), add 5.5 mm [0.217 in] to the L1 (L2) dimension.

# Dimensions of F10 series serial transmission compatible manifold mm [in]

## F10M [Number of valves] SHL [Pilot specifications] (Base piping type)

With manifold outlet port female thread block

(EtherCAT)

(EtherNet/IP) ※ The dimensions is EtherCAT.

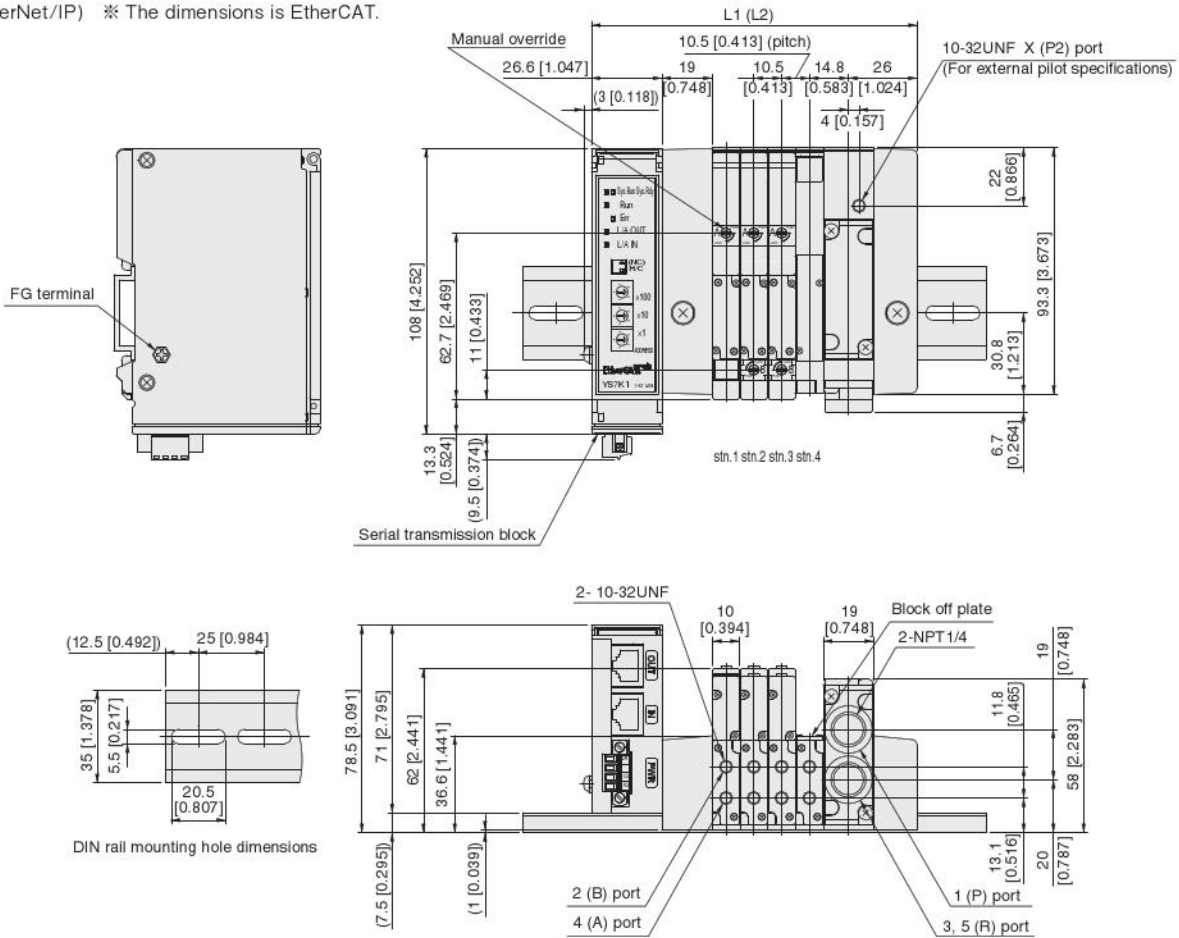

### Unit dimensions

Number of units	L1	Length of DIN rail	L2 <small>note</small>	Length of DIN rail <small>note</small>
2	120.1 [4.728]	150 [5.906]	121.1 [4.768]	175 [6.890]
3	112.6 [4.433]	175 [6.890]	131.6 [5.181]	175 [6.890]
4	123.1 [4.846]	175 [6.890]	142.1 [5.594]	200 [7.874]
5	133.6 [5.260]	175 [6.890]	152.6 [6.008]	200 [7.874]
6	144.1 [5.673]	200 [7.874]	163.1 [6.421]	225 [8.858]
7	154.6 [6.087]	200 [7.874]	173.6 [6.835]	225 [8.858]
8	165.1 [6.500]	225 [8.858]	184.1 [7.248]	225 [8.858]
9	175.6 [6.913]	225 [8.858]	194.6 [7.661]	250 [9.843]
10	186.1 [7.327]	225 [8.858]	205.1 [8.075]	250 [9.843]
11	196.6 [7.740]	250 [9.843]	215.6 [8.488]	275 [10.827]
12	207.1 [8.154]	250 [9.843]	226.1 [8.902]	275 [10.827]
13	217.6 [8.567]	275 [10.827]	236.6 [9.315]	275 [10.827]
14	228.1 [8.980]	275 [10.827]	247.1 [9.728]	300 [11.811]
15	238.6 [9.394]	300 [11.811]	257.6 [10.142]	300 [11.811]
16	249.1 [9.807]	300 [11.811]	268.1 [10.555]	325 [12.795]
17	259.6 [10.220]	325 [12.795]	278.6 [10.969]	350 [13.780]
18	270.1 [10.634]	325 [12.795]	289.1 [11.382]	350 [13.780]
19	280.6 [11.047]	325 [12.795]	299.6 [11.795]	350 [13.780]
20	291.1 [11.461]	350 [13.780]	310.1 [12.209]	375 [14.764]

Note: When two piping blocks are used.  
 \*For right-side mounting wiring (-R), add 5.5 mm [0.217 in] to the L1 (L2) dimension.

**Dimensions of F10 series serial transmission compatible manifold** mm [in]

**F10M** [Number of valves] **SH** [Pilot specifications] (Direct piping type)

With valve outlet port female thread block

(EtherCAT)

(EtherNet/IP) ※ The dimensions is EtherCAT.

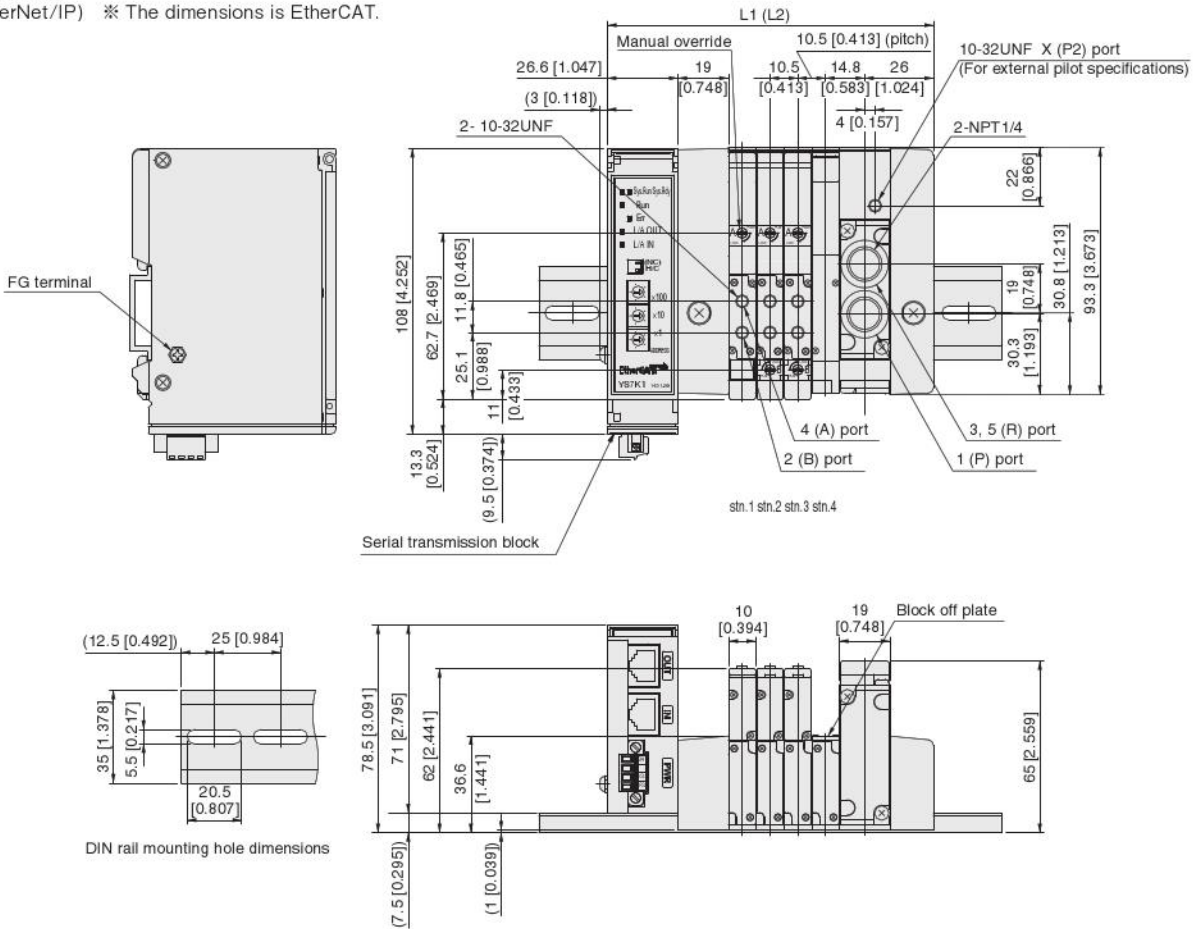

**Unit dimensions**

Number of units	L1	Length of DIN rail	L2 <small>note</small>	Length of DIN rail <small>note</small>
2	120.1 [4.728]	150 [5.906]	121.1 [4.768]	175 [6.890]
3	112.6 [4.433]	175 [6.890]	131.6 [5.181]	175 [6.890]
4	123.1 [4.846]	175 [6.890]	142.1 [5.594]	200 [7.874]
5	133.6 [5.260]	175 [6.890]	152.6 [6.008]	200 [7.874]
6	144.1 [5.673]	200 [7.874]	163.1 [6.421]	225 [8.858]
7	154.6 [6.087]	200 [7.874]	173.6 [6.835]	225 [8.858]
8	165.1 [6.500]	225 [8.858]	184.1 [7.248]	225 [8.858]
9	175.6 [6.913]	225 [8.858]	194.6 [7.661]	250 [9.843]
10	186.1 [7.327]	225 [8.858]	205.1 [8.075]	250 [9.843]
11	196.6 [7.740]	250 [9.843]	215.6 [8.488]	275 [10.827]
12	207.1 [8.154]	250 [9.843]	226.1 [8.902]	275 [10.827]
13	217.6 [8.567]	275 [10.827]	236.6 [9.315]	275 [10.827]
14	228.1 [8.980]	275 [10.827]	247.1 [9.728]	300 [11.811]
15	238.6 [9.394]	300 [11.811]	257.6 [10.142]	300 [11.811]
16	249.1 [9.807]	300 [11.811]	268.1 [10.555]	325 [12.795]
17	259.6 [10.220]	325 [12.795]	278.6 [10.969]	350 [13.780]
18	270.1 [10.634]	325 [12.795]	289.1 [11.382]	350 [13.780]
19	280.6 [11.047]	325 [12.795]	299.6 [11.795]	350 [13.780]
20	291.1 [11.461]	350 [13.780]	310.1 [12.209]	375 [14.764]

Note: When two piping blocks are used.  
 \*For right-side mounting wiring (-R), add 5.5 mm [0.217 in] to the L1 (L2) dimension.

# SOLENOID VALVES

## F15 SERIES

### Contents

Specifications	138
Dimensions of Single Valve Unit	144
Dimensions of Monoblock Manifold	147
Dimensions of Monoblock Manifold, Wire-saving Type	150
Dimensions of PC Board Manifold	152
Dimensions of Split Manifold Non-plug-in Type	153
Dimensions of Split Manifold Plug-in Type	155
Dimensions of Serial Transmission Compatible Manifold	164

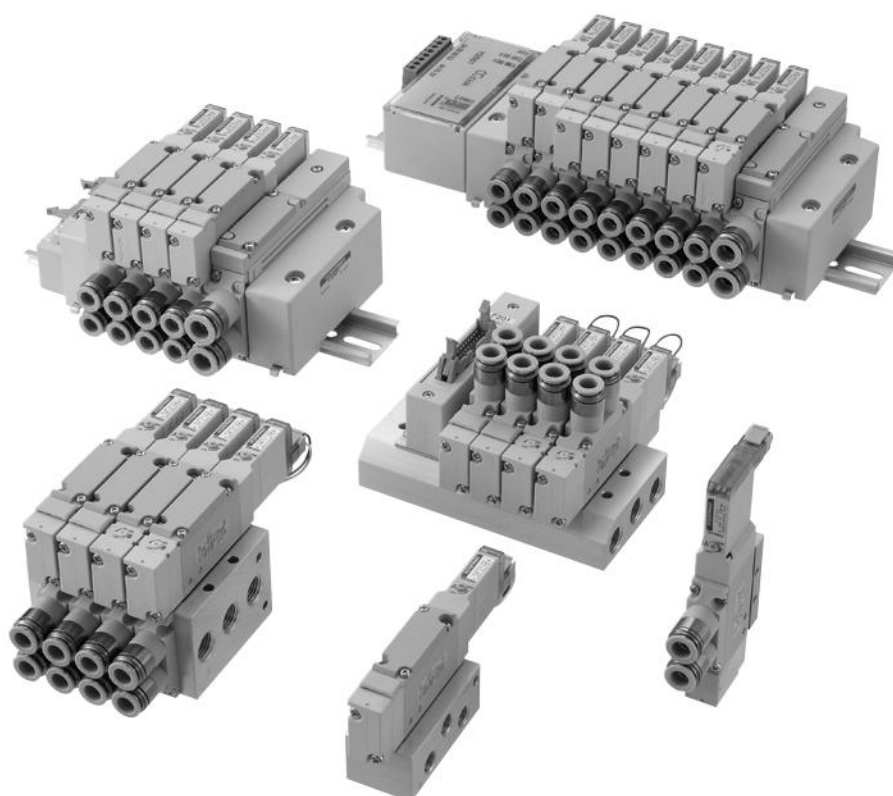

F15 SERIES

# F15 SERIES Specifications

## Specifications

### Basic Models and Valve Functions

Item	Basic model	F15□T0	F15□T1 F15□T2	F15□T3 F15□T4 F15□T5	F15□TA F15□TB F15□TC	
	Number of positions		2 positions		3 positions	4 positions
Number of ports		5				Tandem 3-port
Valve function		Single solenoid only	Both single and double solenoid use	Closed center, Exhaust center, Pressure center	NC/NC, NO/NO, NC/NO	

Remark: For the optional specifications and order codes, see p.44-71.

### Specifications

Item	Basic model	F15□T0 F15□T1 F15□T2	F15□T3 F15□T4 F15□T5	F15□TA F15□TB F15□TC	F15□T0G F15□T1G F15□T2G	F15□T3G F15□T4G F15□T5G	F15□T0V F15□T1V F15□T2V	F15□T3V
	Media		Air					
Operation type		Internal pilot type			External pilot type (for positive pressure)		External pilot type (for vacuum)	
Flow rate characteristics	Sonic conductance C dm <sup>3</sup> /(s·bar) <sup>Note1</sup>	2.05	2.05	1.60	2.05	2.05	2.05	2.05
	Effective area <sup>Note2</sup> mm <sup>2</sup> [Cv]	10.3 [0.57]	10.3 [0.57]	8 [0.44]	10.3 [0.57]	10.3 [0.57]	10.3 [0.57]	10.3 [0.57]
Port size <sup>Note3</sup>		Dual use fitting for φ6 and φ8, Rc1/8, NPT1/8			M5×0.8, 10-32UNF, dual use fitting for φ6 and φ8, Rc1/8, NTP1/8			
Lubrication		Not required						
Operating pressure range	Main valve	0.15~0.7 MPa [22~102 psi.]			0~0.7 MPa [0~102 psi.] <sup>Note4</sup>		-100 kPa~0.15 MPa [-29.53 in.Hg~22 psi.]	
	External pilot	—			0.2~0.7 MPa [29~102 psi.] <sup>Note4</sup>		0.2~0.7 MPa [29~102 psi.]	
Proof pressure	MPa [psi.]	—			1.05 [152]			
Response time <sup>Note5</sup> ms	12VDC, 24VDC	20/25 (30) or below	15/45 (50) or below	20/30 (35) or below	20/25 (30) or below	15/45 (50) or below	20/25 (30) or below	15/45 (50) or below
ON/OFF	100VAC	20/25 or below	15/45 or below	—	20/25 or below	15/45 or below	20/25 or below	15/45 or below
Maximum operating frequency	Hz	5						
Minimum time to energize for self holding <sup>Note6</sup> ms		50	—	—	50	—	50	—
Operating temperature range (atmosphere and media) °C [°F]		5~50 [41~122]						
Shock resistance	m/s <sup>2</sup> [G]	294.2 [30] (245 [25]) Figure in parentheses is for when mounted on the split manifold.						
Mounting direction		Any						

Notes: 1. For details, see the flow rate characteristics on p.141.

2. The effective area is a calculated value, and not a measured value.

3. For details, see the port size on p.140.

4. When the main valve pressure is 0.2~0.7 MPa [29~102 psi.], set the external pilot pressure to the main valve pressure or higher, and to 0.7 MPa [102 psi.] or less.

Remark: Specification values are based on Koganei test standards.

Notes: 5. Values when air pressure is 0.5 MPa [73 psi.]. For switching phase timing in the AC specification, add a maximum of 5 ms to the response time. The values for 2-position valves are those when used as a single solenoid, and the values for 3-position valves are those when switching from the neutral position of closed center. Values in parentheses ( ) are for low-current type.

6. When used as a double solenoid valve. Excludes T0.

### Solenoid Specifications

Item	Rated voltage	12VDC	24VDC (Standard type)	24VDC (Low-current type)	100VAC	120VAC	
	Voltage range	V	10.8~13.2 (12±10%)	21.6~26.4 (24±10%)	21.6~26.4 (24±10%)	90~110 (100±10%)	108~132 (120±10%)
Rated frequency	Hz	—	—	—	50   60	50   60	
Standard	Current (when rated voltage is applied) mA (r.m.s)	33	17	—	8	8.3	
	Power consumption	W	0.4	0.4	—	0.8 VA	1 VA
Low-current type	Current (when rated voltage is applied)	Starting	—	—	17	—	
		Holding	—	—	4.2	—	
	Power consumption	Starting	—	—	0.4	—	—
		Holding	—	—	0.1	—	—
Starting time (standard)	ms	—	—	70	—	—	
Allowable leakage current	mA	2.0	1.0	1.0	1.0	1.0	
Type of insulation		Type B					
Insulation resistance <sup>Note 1</sup>	MΩ	Over 100					
Color of LED indicator <sup>Note2</sup>		14(SA) : Red, 12(SB) : Green					
Surge suppression (as standard)		Surge absorption transistor		Flywheel diode	Bridge diode		

Notes: 1. Value at 500VDC megger.

2. The color of the T0 indicator is red only.

Remark: Specification values are based on Koganei test standards.

## Specifications for DIN Connector (-39□) Type

### Basic Models and Valve Functions

Item	Basic model	F15T0	F15T2	F15T3 F15T4 F15T5
Number of positions		2 positions		3 positions
Number of ports		5		
Valve function		Single solenoid only	Double solenoid only	Closed center, Exhaust center, Pressure center

Remark: For the optional specifications and order codes, see p.44-71.

### Specifications

Item	Basic model	F15T0 F15T2	F15T3 F15T4 F15T5	F15T0G F15T2G	F15T3G F15T4G F15T5G	F15T0V F15T2V	F15T3V
Media		Air					
Operation type		Internal pilot type		External pilot type (for positive pressure)		External pilot type (for vacuum)	
Flow rate characteristics	Sonic conductance C dm <sup>3</sup> /(s·bar) <sup>Note1</sup>	2.05	2.05	2.05	2.05	2.05	2.05
	Effective area <sup>Note2</sup> mm <sup>2</sup> [Cv]	10.3 [0.57]	10.3 [0.57]	10.3 [0.57]	10.3 [0.57]	10.3 [0.57]	10.3 [0.57]
Port size <sup>Note3</sup>		Dual use fitting for φ6 and φ8, Rc1/8, NPT1/8		M5×0.8, 10-32UNF, dual use fitting for φ6 and φ8, Rc1/8, NPT1/8			
Lubrication		Not required					
Operating pressure range	Main valve	0.15~0.7 MPa [22~102 psi.]		0~0.7 MPa [0~102 psi.] <sup>Note4</sup>		-100 kPa~0.15 MPa [-29.53 in.Hg~22 psi.]	
	External pilot	—		0.2~0.7 MPa [29~102 psi.] <sup>Note4</sup>		0.2~0.7 MPa [29~102 psi.]	
Proof pressure	MPa [psi.]	1.05 [152]					
Response time <sup>Note5</sup> ON/OFF	ms	20/30 or below	15/50 or below	20/30 or below	15/50 or below	20/30 or below	15/50 or below
Maximum operating frequency	Hz	5					
Minimum time to energize for self holding <sup>Note6</sup>	ms	50	—	50	—	50	—
Operating temperature range (atmosphere and media) °C [°F]		5~50 [41~122]					
Shock resistance	m/s <sup>2</sup> [G]	294.2 [30] (245 [25]) Figure in parentheses is for when mounted on the split-type manifold.					
Mounting direction		Any					

Notes: 1. For details, see the flow rate characteristics on p.141.

2. The effective area is a calculated value, and not a measured value.

3. For details, see the port size on p.140.

4. When the main valve pressure is 0.2~0.7 MPa [29~102 psi.], set the external pilot pressure to the main valve pressure or higher, and to 0.7 MPa [102 psi.] or less.

Notes: 5. Values when air pressure is 0.5 MPa [73 psi.]. For switching phase timing in the AC specification, add a maximum of 5 ms to the response time. The values for 2-position valves are those when used as a single solenoid, and the values for 3-position valves are those when switching from the neutral position of closed center.

6. In the case of double solenoid.

Remark: Specification values are based on Koganei test standards.

### Solenoid Specifications for DIN Connector (-39□) Type

Item	Rated voltage	12VDC	24VDC	120VAC		240VAC	
Voltage range	V	10.8~13.2 (12±10%)	21.6~26.4 (24±10%)	90~132		180~264	
Current	Frequency	—	—	50	60	50	60
	Starting	mA (r.m.s)	—	43	38	22	19
	Holding	mA (r.m.s)	140 (1.7W)	75 (1.8W)	29	24	14
Allowable leakage current	mA	8	4	4		2	
Insulation resistance <sup>Note</sup>	MΩ	Over 100					
Surge suppression (as standard)		Surge absorption transistor		Varistor		Varistor	

Note: Value at 500VDC megger.

Remark: Specification values are based on Koganei test standards.

## Cylinder Operating Speed

### How to obtain cylinder speed

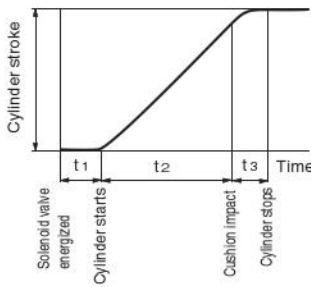

### Measuring conditions

- Air pressure : 0.5 MPa [73 psi.]
- Piping (outer diameter × inner diameter × length) :  $\phi 8 \times \phi 6 \times 1000$  mm [39 in.]
- Fitting : Quick fitting TS8-01
- Load ratio =  $\frac{\text{Load}}{\text{Cylinder theoretical thrust}}$  (%)
- Cylinder stroke : 150 mm [5.91 in.]

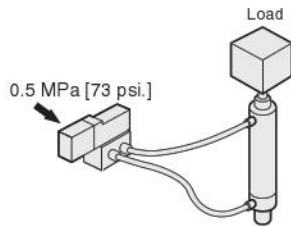

### Maximum operating speed

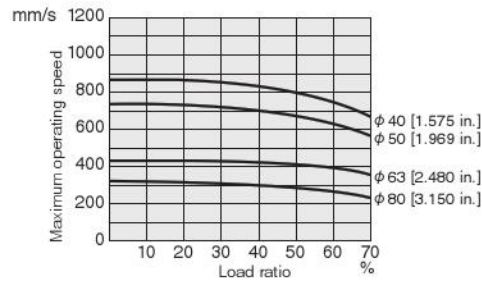

### Delay time

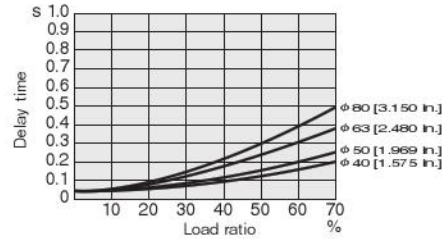

Note: Delay time may vary according to the cylinder stroke.

## Flow Rate

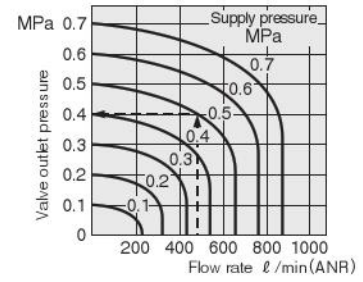

### How to read the graph

When the supply pressure is 0.5 MPa [73 psi.] and flow rate is 500 l/min [17.7 ft<sup>3</sup>/min.] (ANR), the valve outlet pressure becomes 0.4 MPa [58 psi.].

- 1 mm/s = 0.0394 in./sec.
- 1 MPa = 145 psi.
- 1 l/min = 0.0353 ft<sup>3</sup>/min.

## Port Size

Description/Piping specification		PR	X (P2)	4 (A), 2 (B)	1 (P), 3 (R2), 5 (R1), 3, 5 (R)
Single Unit	With sub-base	M5×0.8, 10-32UNF	M5×0.8, 10-32UNF	Rc1/8, NPT1/8	Rc1/8, NPT1/8
	With female thread block	—	—	Rc1/8, NPT1/8	Rc1/8, NPT1/8
	With dual use fitting block	—	—	Dual use fitting for $\phi 6$ and $\phi 8$	Rc1/8, NPT1/8
	With single use fitting block	—	—	$\phi 6$ or $\phi 8$	Rc1/8, NPT1/8
Manifold	Monoblock type with female thread block, and PC board type with female thread block	M5×0.8, 10-32UNF	M5×0.8, 10-32UNF	Rc1/8, NPT1/8	Rc1/4, NPT1/4
	Monoblock type with fitting block, and PC board type with fitting block	M5×0.8, 10-32UNF	M5×0.8, 10-32UNF	Dual use fitting for $\phi 6$ and $\phi 8$	Rc1/4, NPT1/4
	Monoblock type with single use fitting block, and PC board type with single use fitting block	M5×0.8, 10-32UNF	M5×0.8, 10-32UNF	$\phi 6$ or $\phi 8$	Rc1/4, NPT1/4
	Split type with female thread block, and serial transmission type with female thread block	—	M5×0.8, 10-32UNF	Rc1/8, NPT1/8	Rc1/4, NPT1/4
	Split type with fitting block, and serial transmission type with fitting block	—	M5×0.8, 10-32UNF	Dual use fitting for $\phi 6$ and $\phi 8$	Dual use fitting for $\phi 8$ and $\phi 10$
Split type with single use fitting block, and serial transmission type with single use fitting block	—	M5×0.8, 10-32UNF	$\phi 6$ or $\phi 8$	Single use fitting for $\phi 8$ or $\phi 10$	

## Flow Rate Characteristics

### ● When used as a single unit

Basic model	1 (P) → 2 (B) / 1 (P) → 4 (A)		2 (B) → 3 (R2) / 4 (A) → 5 (R1)	
	Sonic conductance C dm <sup>3</sup> /(s·bar)	Critical pressure ratio b	Sonic conductance C dm <sup>3</sup> /(s·bar)	Critical pressure ratio b
F15□T0-A2 F15□T1-A2 F15□T2-A2	1.76	0.25	1.72	0.26
F15□T3-A2 F15□T4-A2 F15□T5-A2	1.78	0.25	1.72	0.24
F15□TA-A2 F15□TB-A2 F15□TC-A2	1.53	0.26	1.61	0.23
F15□T0-F3 F15□T1-F3 F15□T2-F3	1.80	0.25	1.71	0.29
F15□T3-F3 F15□T4-F3 F15□T5-F3	1.81	0.23	1.61	0.27
F15□TA-F3 F15□TB-F3 F15□TC-F3	1.57	0.28	1.57	0.24
F15□T0-F4 F15□T1-F4 F15□T2-F4	1.83	0.30	1.62	0.33
F15□T3-F4 F15□T4-F4 F15□T5-F4	1.57	0.36	1.51	0.25
F15□TA-F4 F15□TB-F4 F15□TC-F4	1.54	0.31	1.55	0.27

Basic model	1 (P) → 2 (B) / 1 (P) → 4 (A)		2 (B) → 3 (R2) / 4 (A) → 5 (R1)	
	Sonic conductance C dm <sup>3</sup> /(s·bar)	Critical pressure ratio b	Sonic conductance C dm <sup>3</sup> /(s·bar)	Critical pressure ratio b
F15□T0-F5 F15□T1-F5 F15□T2-F5	1.62	0.38	1.56	0.28
F15□T3-F5 F15□T4-F5 F15□T5-F5	1.57	0.36	1.51	0.25
F15□TA-F5 F15□TB-F5 F15□TC-F5	1.44	0.34	1.46	0.24
F15□T0-F6 F15□T1-F6 F15□T2-F6	1.86	0.30	1.70	0.30
F15□T3-F6 F15□T4-F6 F15□T5-F6	1.84	0.29	1.64	0.29
F15□TA-F6 F15□TB-F6 F15□TC-F6	1.58	0.31	1.57	0.31

### ● When mounted on a manifold

Manifold model		F15M□F (FP)		F15M□A (AP)		F15M□N (P) (S)	
		1 (P) → 2 (B) / 1 (P) → 4 (A)	2 (B) → 3 (R2) / 4 (A) → 5 (R1)	1 (P) → 2 (B) / 1 (P) → 4 (A)	2 (B) → 3 (R2) / 4 (A) → 5 (R1)	1 (P) → 2 (B) / 1 (P) → 4 (A)	2 (B) → 3 (R2) / 4 (A) → 5 (R1)
Valve model		Sonic conductance C dm <sup>3</sup> /(s·bar)		Sonic conductance C dm <sup>3</sup> /(s·bar)		Sonic conductance C dm <sup>3</sup> /(s·bar)	
F15□T0□ F15□T1□ F15□T2□	Outlet port dual use fitting for φ6 and φ8 ※These are the cases of φ8.	1.72	1.56	1.56	1.46	2.01	1.84
F15□T3□ F15□T4□ F15□T5□		1.72	1.53	1.57	1.43	2.02	1.78
F15□TA□ F15□TB□ F15□TC□		1.48	1.47	1.38	1.34	1.57	1.61
F15□T0□ F15□T1□ F15□T2□	Outlet port φ6 fitting	1.50	1.46	1.38	1.39	1.67	1.70
F15□T3□ F15□T4□ F15□T5□		1.52	1.46	1.39	1.37	1.67	1.66
F15□TA□ F15□TB□ F15□TC□		1.37	1.39	1.28	1.30	1.41	1.50
F15□T0□ F15□T1□ F15□T2□	Outlet port φ8 fitting	1.73	1.56	1.60	1.47	2.05	1.83
F15□T3□ F15□T4□ F15□T5□		1.72	1.54	1.60	1.45	2.05	1.78
F15□TA□ F15□TB□ F15□TC□		1.49	1.48	1.39	1.36	1.58	1.60

Notes: 1. When the individual air supply spacer or the individual air exhaust spacer, the back pressure prevention valve, or the stop valve is used, sonic conductance decreases by about 30%.

2: For the flow rate characteristics of other outlet ports, consult us.

Remark: Specification values are based on Koganei test standards.

# Mass

## Single Valve Unit Mass

g [oz.]

F15□T□□	F15□T□□-A1	F15□T□□-A2	F15□T□□-FJ	F15□T□□-FJ5	F15□T□□-FJ6
Outlet portion None	Outlet portion With plate	Outlet portion With plate	Outlet portion With dual use fitting block	Outlet portion With φ6 fitting block	Outlet portion With φ8 fitting block
Inlet portion None	Inlet portion None	Inlet portion With A type sub-base	Inlet portion None	Inlet portion None	Inlet portion None
82 [2.89]	101 [3.56]	210 [7.41]	114 [4.02]	125 [4.41]	130 [4.59]

g [oz.]

F15□T□□-FM	F15□T□□-F3	F15□T□□-F4	F15□T□□-F5	F15□T□□-F6
Outlet portion With female thread block	Outlet portion With dual use fitting block	Outlet portion With female thread block	Outlet portion With φ6 fitting block	Outlet portion With φ8 fitting block
Inlet portion None	Inlet portion With female thread block	Inlet portion With female thread block	Inlet portion With female thread block	Inlet portion With female thread block
104 [3.67]	127 [4.48]	117 [4.13]	138 [4.87]	143 [5.04]

Basic Type **F15T0** is 13 g [0.46 oz.] less than the mass shown above.

## Monoblock Manifold Mass (single valve unit included)

g [oz.]

Monoblock manifold	Mass calculation of each unit			
	4(A), 2(B) ports outlet specifications			
	Female thread block	Dual use fitting block	φ6 fitting block	φ8 fitting block
A type	$(230 \times n) + 128$ $[(8.11 \times n) + 4.51]$	$(240 \times n) + 128$ $[(8.47 \times n) + 4.51]$	$(251 \times n) + 128$ $[(8.85 \times n) + 4.51]$	$(256 \times n) + 128$ $[(9.03 \times n) + 4.51]$
F type	$(156 \times n) + 116$ $[(5.50 \times n) + 4.09]$	$(166 \times n) + 116$ $[(5.86 \times n) + 4.09]$	$(177 \times n) + 116$ $[(6.24 \times n) + 4.09]$	$(182 \times n) + 116$ $[(6.42 \times n) + 4.09]$

g [oz.]

Monoblock manifold	Additional mass (wire-saving type)		
	Wiring specification		
	-F100N, -F101N	-F200N, -F201N, -F260N	-D250N, -D251N
A type	$340 + 4n$ $[11.99 + 0.14n]$	$342 + 4n$ $[12.06 + 0.14n]$	$346 + 4n$ $[12.20 + 0.14n]$
F type	$192 + 4n$ $[6.77 + 0.14n]$	$194 + 4n$ $[6.84 + 0.14n]$	$198 + 4n$ $[6.98 + 0.14n]$

Calculation example : **F15M8AM**

stn.1~stn.8 **F15T1-A1-PS DC24V**

$(230 \times 8) + 128 = 1968$  g [69.42 oz.]

When mounting the block-off plate, subtract 100 g [3.53 oz.] per unit from the above calculation result.

When mounting the **F15□T0** specification valve, subtract 13 g [0.46 oz.] per unit from the above calculation result.

## PC Board Manifold Mass (single valve unit included)

g [oz.]

PC board manifold	Mass calculation of each unit				Circuit board and connector portion
	4(A), 2(B) ports outlet specifications				
	Female thread block	Dual use fitting block	φ6 fitting block	φ8 fitting block	
A type	$(230 \times n) + 128$ $[(8.11 \times n) + 4.51]$	$(240 \times n) + 128$ $[(8.47 \times n) + 4.51]$	$(251 \times n) + 128$ $[(8.85 \times n) + 4.51]$	$(256 \times n) + 128$ $[(9.03 \times n) + 4.51]$	$(2 \times n) + 29$
F type	$(182 \times n) + 121$ $[(5.71 \times n) + 4.27]$	$(172 \times n) + 121$ $[(6.07 \times n) + 4.27]$	$(183 \times n) + 121$ $[(6.46 \times n) + 4.27]$	$(188 \times n) + 121$ $[(6.63 \times n) + 4.27]$	$[(0.07 \times n) + 1.02]$

Calculation example : **F15M8APM-F201-W**

stn.1~stn.8 **F15T1-A1-PP DC24V**

$(230 \times 8) + 128 + (2 \times 8) + 29 = 2013$  g [71.01 oz.]

When mounting the block-off plate, subtract 100 g [3.53 oz.] per unit from the above calculation result.

When mounting the **F15□T0** specification valve, subtract 13 g [0.46 oz.] per unit from the above calculation result.

## Mass of Split Manifold and Serial Transmission Compatible Manifold

Because the valve and manifold have the same output specifications, their mass is the same. The mass can only be changed by choosing a different type of inlet/outlet block.

### Mass of Split Manifold Non-Plug-in Type (single valve unit included)

g [oz.]

Non-plug-in type	Mass calculation of each unit			
	4(A), 2(B) ports outlet specifications			
	Female thread block	Dual use fitting block	φ 6 fitting block	φ 8 fitting block
	$(173 \times n) + 249$ [(6.10 × n) + 8.78]	$(183 \times n) + 249$ [(6.46 × n) + 8.78]	$(194 \times n) + 249$ [(6.84 × n) + 8.78]	$(199 \times n) + 249$ [(7.02 × n) + 8.78]
g [oz.]				
Additional mass				
Piping block specification				
Female thread block	Dual use fitting block	φ 8 fitting block	φ 10 fitting block	
153 [5.40]	167 [5.89]	191 [6.74]	201 [7.09]	

Calculation example : **F15M8N-MR**

**stn.1~stn.8 F15T1-A1-PS DC24V**

$(173 \times 8) + 249 + 153 = 1786$  g [63.00 oz.]

When mounting the block-off plate, subtract 100 g [3.53 oz.] per unit from the above calculation result.

When mounting the **F15□T0** specification valve, subtract 13 g [0.46 oz.] per unit from the above calculation result.

### Mass of Split Manifold Plug-in Type/ Serial Transmission Compatible Manifold (single valve unit included)

g [oz.]

Plug-in type Serial transmission compatible manifold	Mass calculation of each unit			
	4(A), 2(B) ports outlet specifications			
	Female thread block	Dual use fitting block	φ 6 fitting block	φ 8 fitting block
	$(177 \times n) + 249$ [(6.24 × n) + 8.78]	$(187 \times n) + 249$ [(6.60 × n) + 8.78]	$(198 \times n) + 249$ [(6.98 × n) + 8.78]	$(203 \times n) + 249$ [(7.16 × n) + 8.78]
g [oz.]				
Additional mass				
Piping block specification				
Female thread block	Dual use fitting block	φ 8 fitting block	φ 10 fitting block	
153 [5.40]	167 [5.89]	191 [6.74]	201 [7.09]	
g [oz.]				
Additional mass				
Wiring block specification				
<b>-F100□□, -F101□□</b>	<b>-F200□□, -F201□□, -F260□□</b>	<b>-D250□□, -D251□□</b>	<b>-D370NU</b>	<b>-T200</b>
32 [1.13]	34 [1.20]	39 [1.38]	72 [2.54]	158 [5.57]
g [oz.]				
Additional mass				
Serial transmission block specification				
Stand-alone type	Integrated type	EtherCAT	EtherNet/IP	
231 [8.15]	138 [4.87]	100 [3.53]	110 [3.88]	

Calculation example : **F15M8PM-MR-F201 DC24V**

**stn.1~stn.8 F15T1-A1 DC24V**

$(177 \times 8) + 249 + 153 + 34 = 1852$  g [65.33 oz.]

When mounting the block-off plate, subtract 100 g [3.53 oz.] per unit from the above calculation result.

When mounting the **F15□T0** specification valve, subtract 13 g [0.46 oz.] per unit from the above calculation result.

**F15T** Valve specifications **-F3-PS**

With outlet port dual use fitting block  
 With inlet port female thread block  
 S type plug connector

\* For T0 Type dimensions, see page 145.

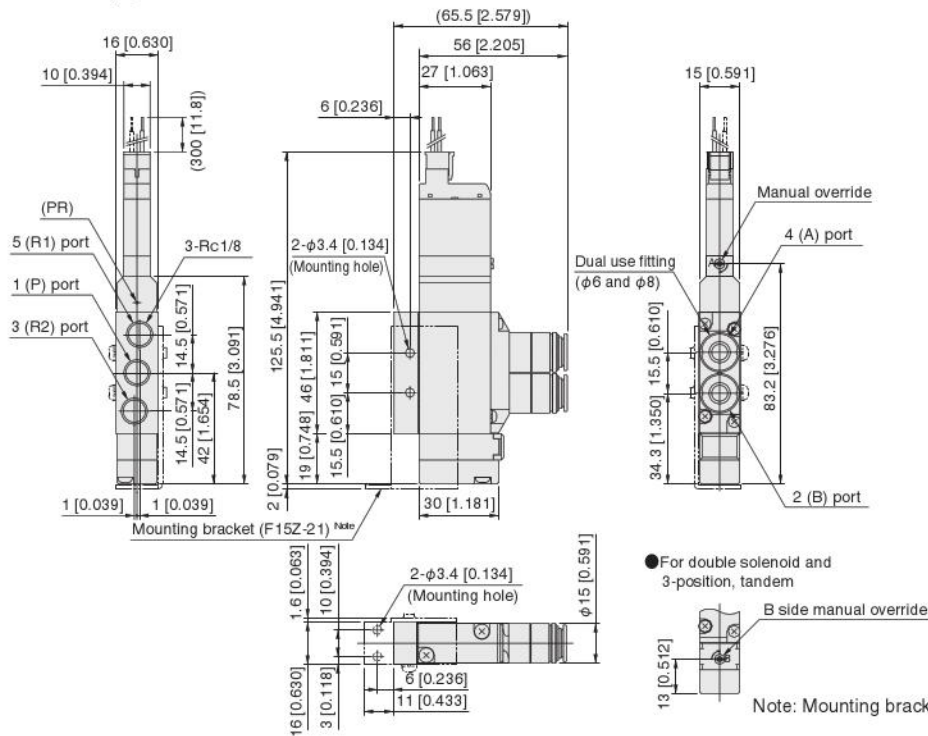

● For double solenoid and 3-position, tandem  
 B side manual override  
 Note: Mounting brackets are additional parts (options).

**F15T** Valve specifications **-F4-PS**

**F15T** Valve specifications **-F4H-PS**

With outlet port female thread block  
 With inlet port female thread block  
 S type plug connector

\* For T0 Type dimensions, see page 145.

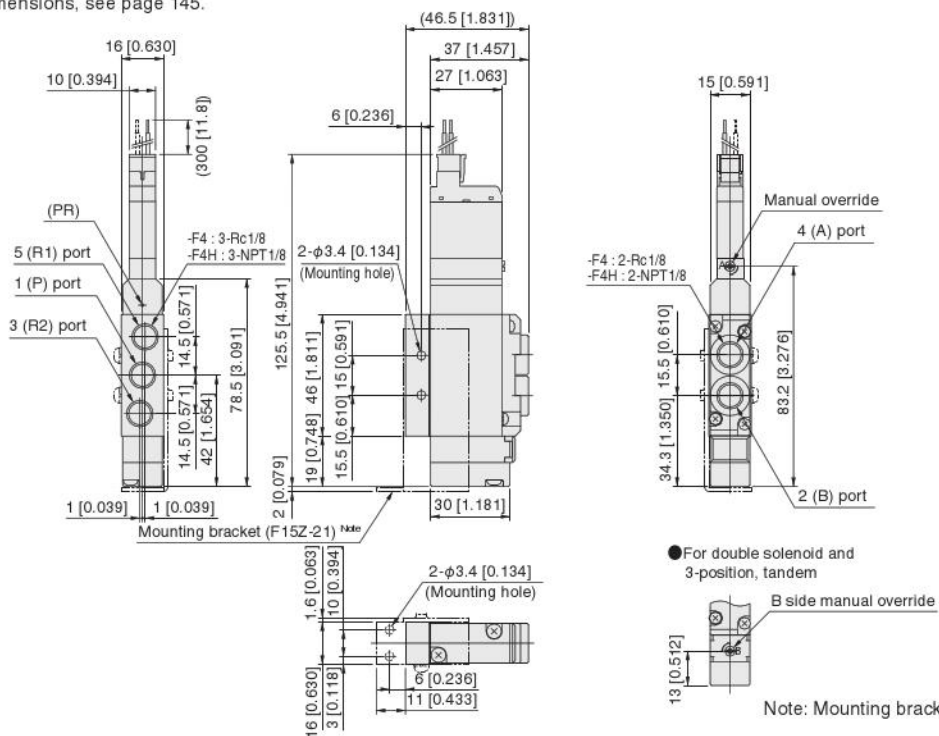

● For double solenoid and 3-position, tandem  
 B side manual override  
 Note: Mounting brackets are additional parts (options).

### F15T0-F □ -PS

With outlet port single use fitting block  
 With inlet port female thread block  
 S type plug connector

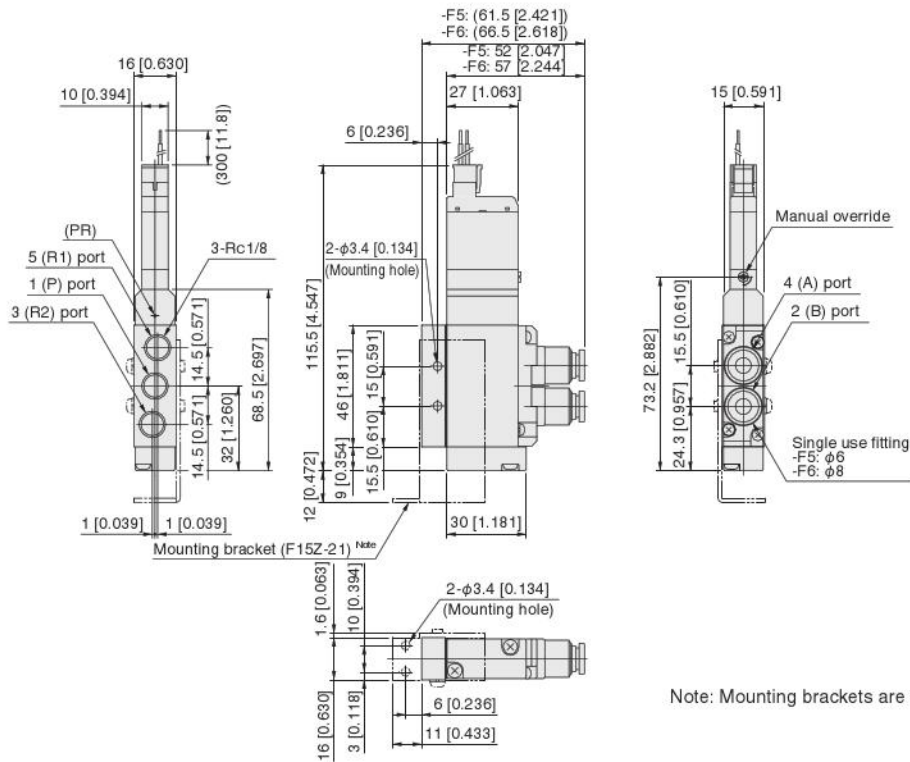

Note: Mounting brackets are additional parts (options).

Dimensions of F15 series single valve unit mm [in]

F15T Valve specifications Operation system -A2-PS

F15T Valve specifications Operation system -A2H-PS

With A-type sub-base  
S type plug connector

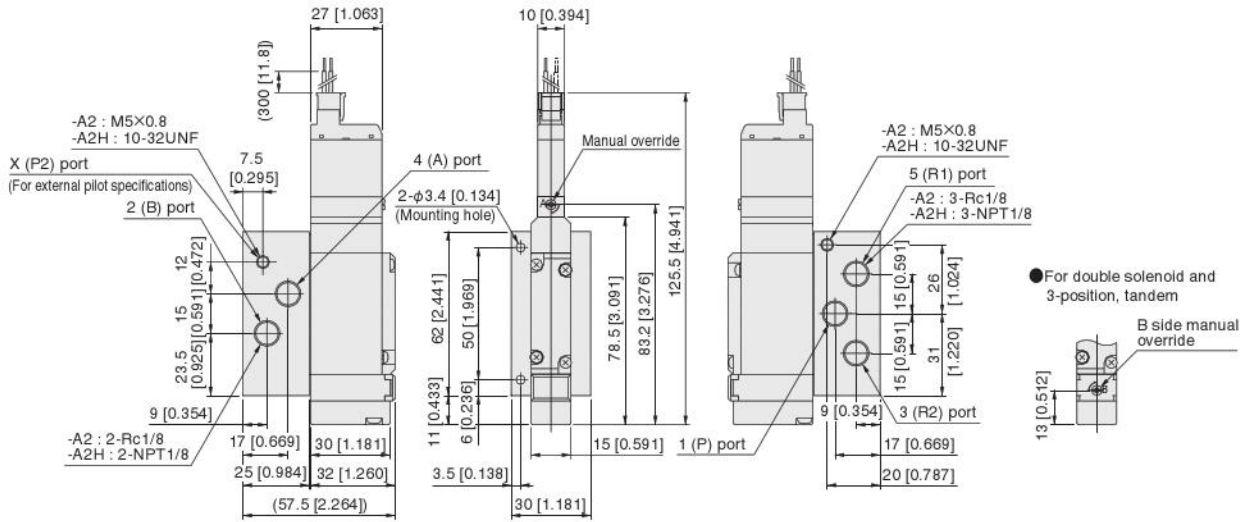

Note: The overall valve length of the T0 type is 10 mm [0.394 in] shorter (end cover side extension is 10 mm [0.394 in] less).

Options

● L-type plug connector: -PL

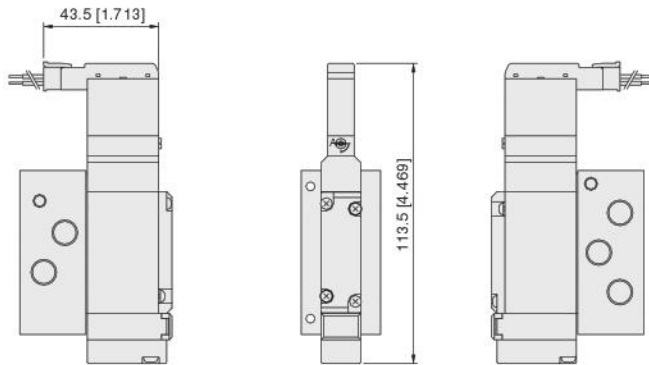

● Manual lever: -R

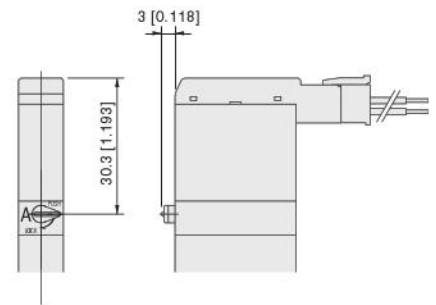

Note: The overall valve length of the T0 type is 10 mm [0.394 in] shorter (end cover side extension is 10 mm [0.394 in] less).

● Solenoid with DIN type connector: -39

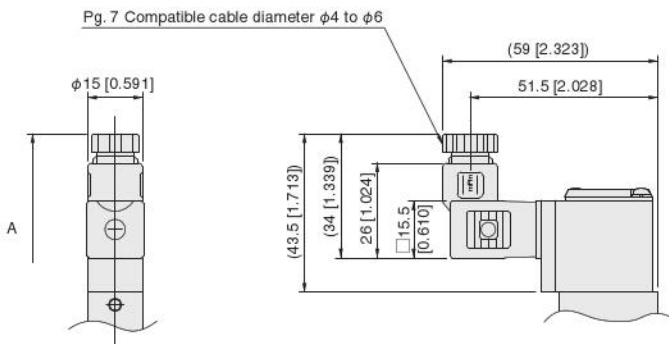

● Protruding lock type manual override: -83

Model	Symbol	A (Full length)
F15T0		117.2 [4.614]
F15T2		170.4 [6.709]
F15T3 to T5		180.4 [7.102]

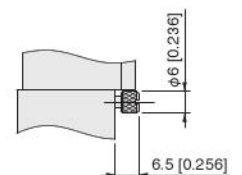

Dimensions of F15 series monoblock manifold A type mm [in]

**F15M** [Number of valves] **A M J** [Pilot specifications] (Base piping type)

Monoblock manifold A type  
With manifold outlet port dual use fitting block  
S type plug connector

● Internal pilot specifications

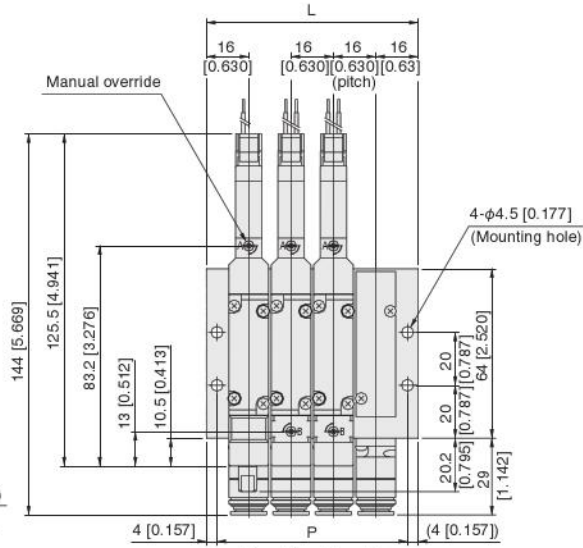
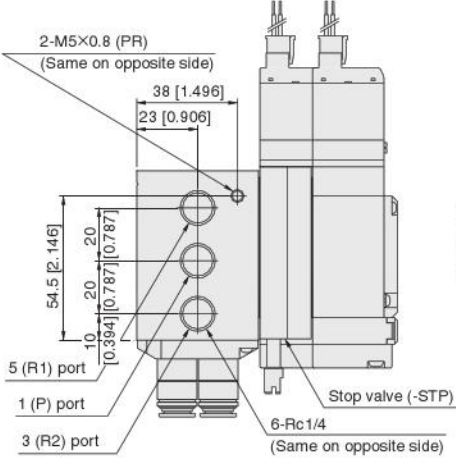

● External pilot specifications

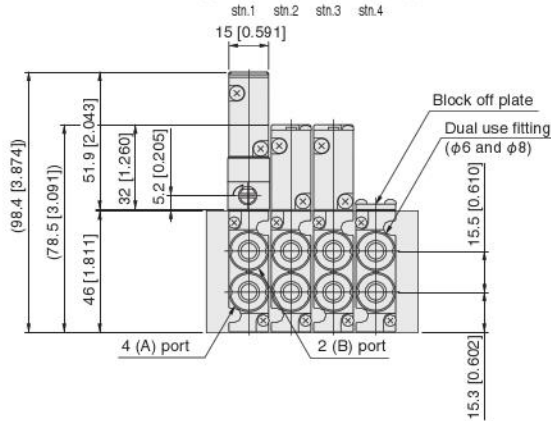
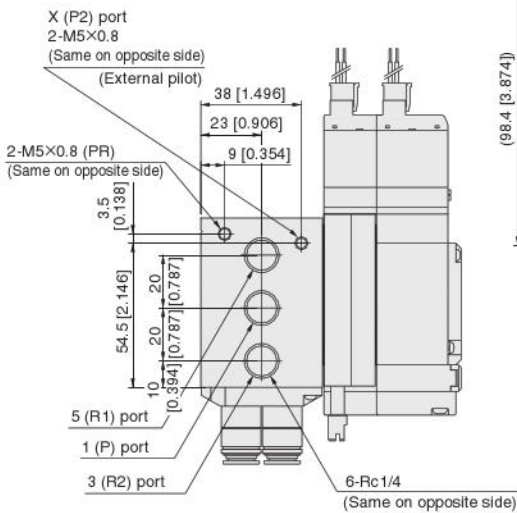

Unit dimensions

Number of units	L	P
2	48 [1.890]	40 [1.575]
3	64 [2.520]	56 [2.205]
4	80 [3.150]	72 [2.835]
5	96 [3.780]	88 [3.465]
6	112 [4.409]	104 [4.094]
7	128 [5.039]	120 [4.724]
8	144 [5.669]	136 [5.354]
9	160 [6.299]	152 [5.984]
10	176 [6.929]	168 [6.614]
11	192 [7.559]	184 [7.244]
12	208 [8.189]	200 [7.874]
13	224 [8.819]	216 [8.504]
14	240 [9.449]	232 [9.134]
15	256 [10.079]	248 [9.764]
16	272 [10.709]	264 [10.394]
17	288 [11.339]	280 [11.024]
18	304 [11.969]	296 [11.654]
19	320 [12.599]	312 [12.283]
20	336 [13.228]	328 [12.913]

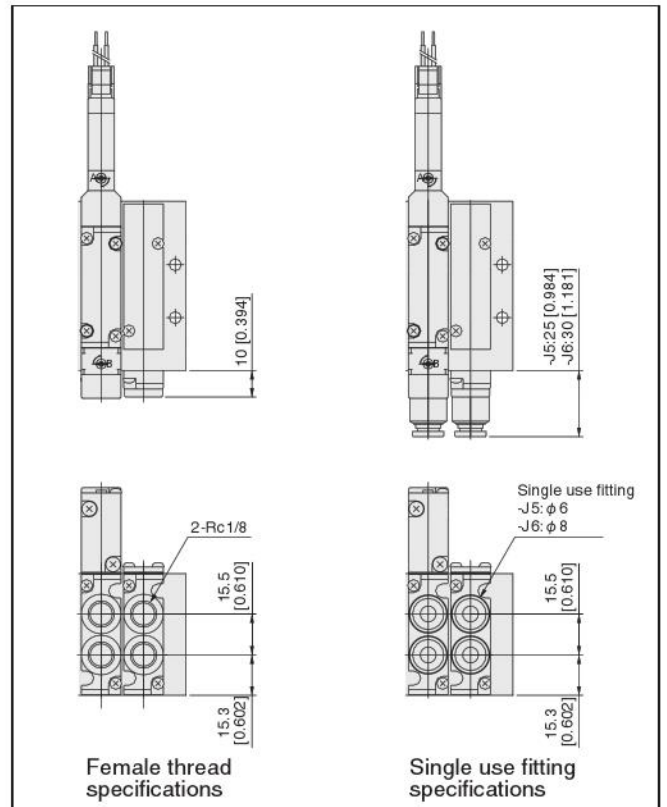

F15 SERIES

**Dimensions of F15 series monoblock manifold A type** mm [in]

**F15M** Number of valves **AHL** Pilot specifications (Base piping type)

Monoblock manifold A type  
 With manifold outlet port female thread block  
 S type plug connector

● **Internal pilot specifications**

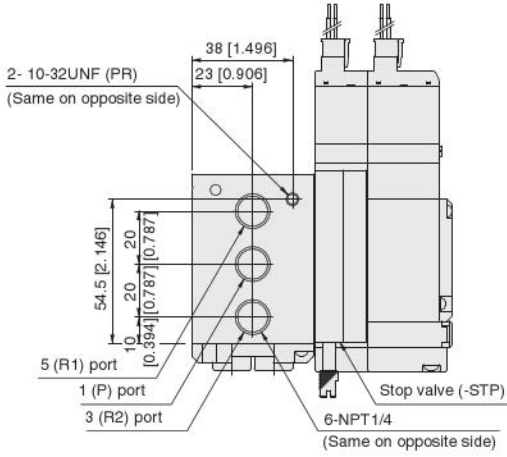

● **External pilot specifications**

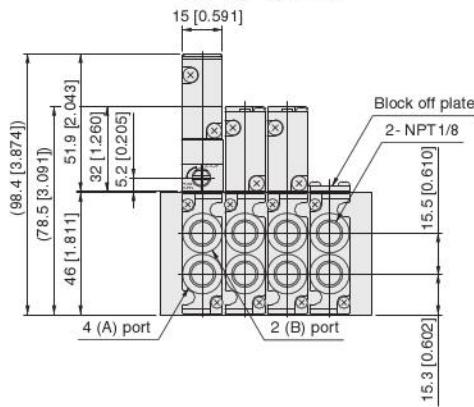
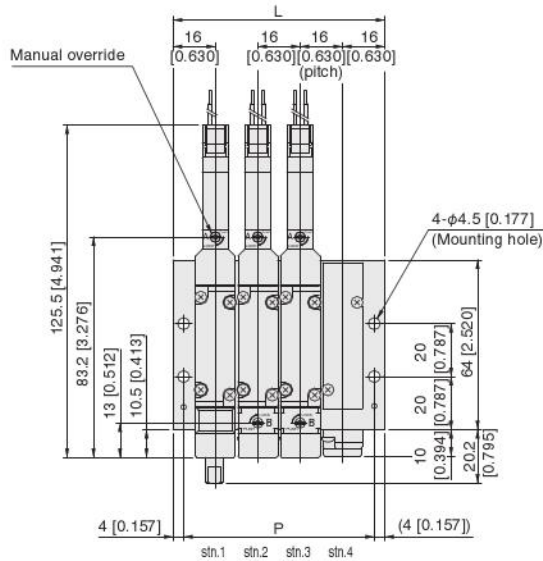
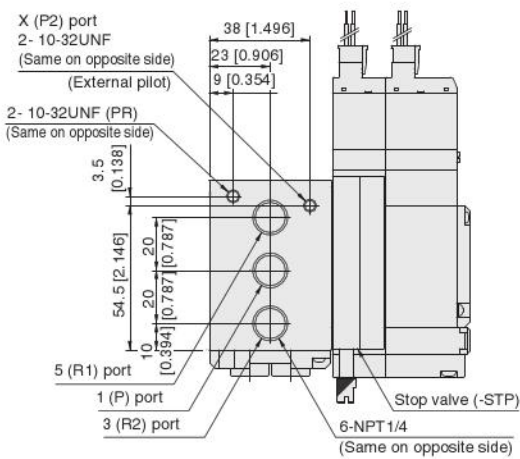

**Unit dimensions**

Number of units	L	P
2	48 [1.890]	40 [1.575]
3	64 [2.520]	56 [2.205]
4	80 [3.150]	72 [2.835]
5	96 [3.780]	88 [3.465]
6	112 [4.409]	104 [4.094]
7	128 [5.039]	120 [4.724]
8	144 [5.669]	136 [5.354]
9	160 [6.299]	152 [5.984]
10	176 [6.929]	168 [6.614]
11	192 [7.559]	184 [7.244]
12	208 [8.189]	200 [7.874]
13	224 [8.819]	216 [8.504]
14	240 [9.449]	232 [9.134]
15	256 [10.079]	248 [9.764]
16	272 [10.709]	264 [10.394]
17	288 [11.339]	280 [11.024]
18	304 [11.969]	296 [11.654]
19	320 [12.599]	312 [12.283]
20	336 [13.228]	328 [12.913]

**Dimensions of F15 series monoblock manifold F type** mm [in]

**F15M** [Number of valves] **F** (Direct piping type)

Monoblock manifold F type  
With valve outlet port dual use fitting block  
S type plug connector

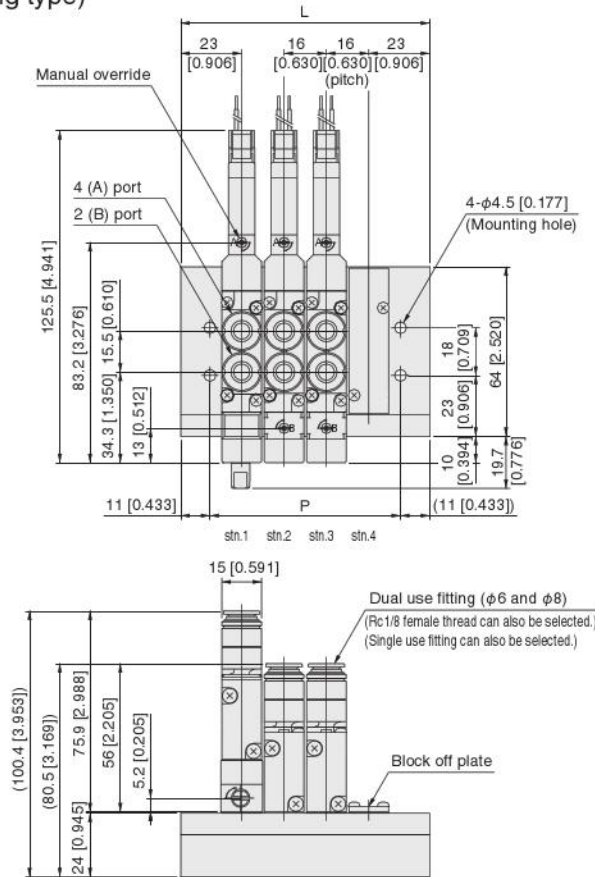
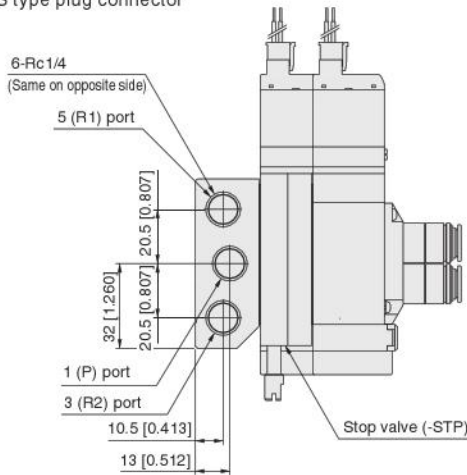

Note: The overall valve length of the T0 type is 10 mm [0.394 in] shorter (end cover side protrusion is 10 mm [0.394 in] less).

**Unit dimensions**

Number of units	L	P
2	62 [2.441]	40 [1.575]
3	78 [3.071]	56 [2.205]
4	94 [3.701]	72 [2.835]
5	110 [4.331]	88 [3.465]
6	126 [4.961]	104 [4.094]
7	142 [5.591]	120 [4.724]
8	158 [6.220]	136 [5.354]
9	174 [6.850]	152 [5.984]
10	190 [7.480]	168 [6.614]
11	206 [8.110]	184 [7.244]
12	222 [8.740]	200 [7.874]
13	238 [9.370]	216 [8.504]
14	254 [10.000]	232 [9.134]
15	270 [10.630]	248 [9.764]
16	286 [11.260]	264 [10.394]
17	302 [11.890]	280 [11.024]
18	318 [12.520]	296 [11.654]
19	334 [13.150]	312 [12.283]
20	350 [13.780]	328 [12.913]

**F15M** [Number of valves] **FH** (Direct piping type)

Monoblock manifold F type  
With valve outlet port female thread block  
S type plug connector

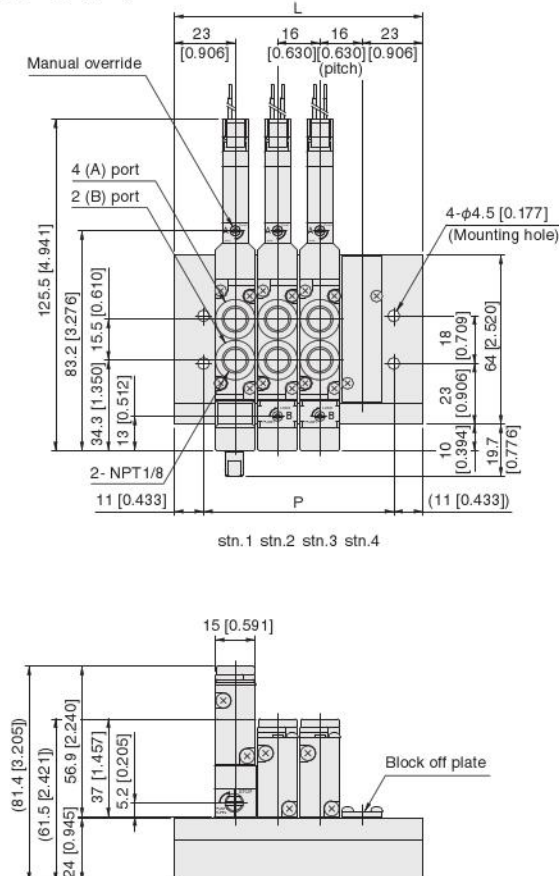
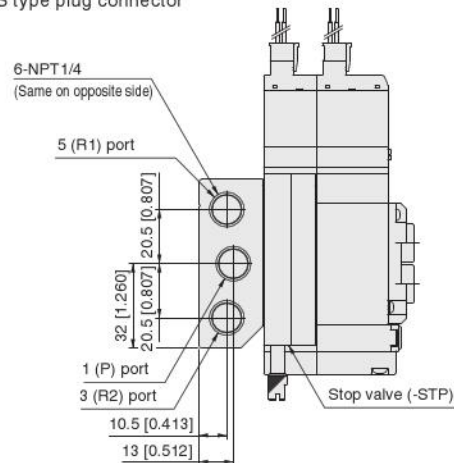

Note: The overall valve length of the T0 type is 10 mm [0.394 in] shorter (end cover side protrusion is 10 mm [0.394 in] less).

**Unit dimensions**

Number of units	L	P
2	62 [2.441]	40 [1.575]
3	78 [3.071]	56 [2.205]
4	94 [3.701]	72 [2.835]
5	110 [4.331]	88 [3.465]
6	126 [4.961]	104 [4.094]
7	142 [5.591]	120 [4.724]
8	158 [6.220]	136 [5.354]
9	174 [6.850]	152 [5.984]
10	190 [7.480]	168 [6.614]
11	206 [8.110]	184 [7.244]
12	222 [8.740]	200 [7.874]
13	238 [9.370]	216 [8.504]
14	254 [10.000]	232 [9.134]
15	270 [10.630]	248 [9.764]
16	286 [11.260]	264 [10.394]
17	302 [11.890]	280 [11.024]
18	318 [12.520]	296 [11.654]
19	334 [13.150]	312 [12.283]
20	350 [13.780]	328 [12.913]

F15 SERIES

**F15M** Number of valves **AM** Pilot specifications (Base piping type)

Monoblock manifold A type, wire saving type  
With manifold outlet port dual use fitting block  
Dimensions show flat cable connector 20-pin specifications

● **Internal pilot specifications**

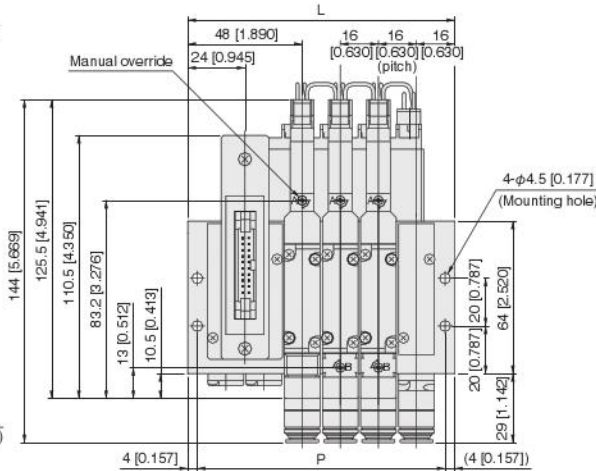
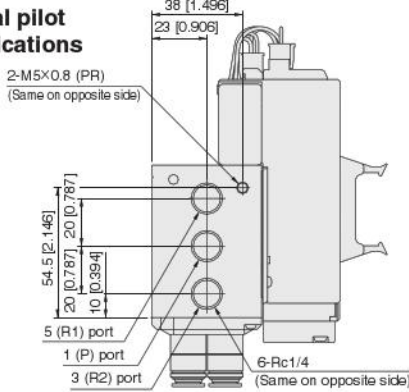

● **External pilot specifications**

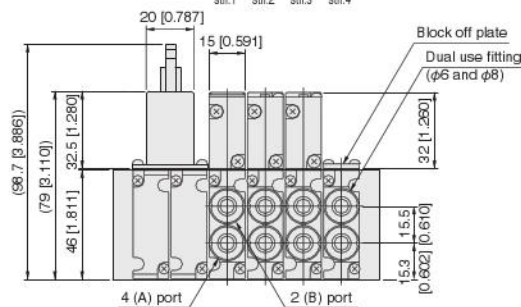
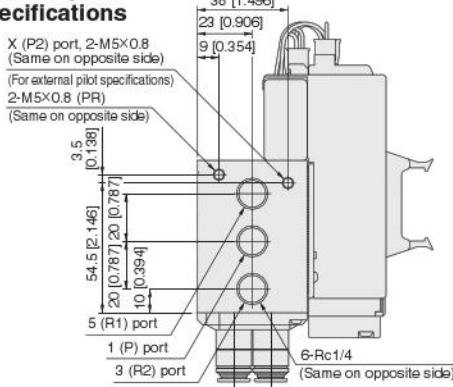

**Unit dimensions**

Number of units	L	P
2	80 [3.150]	72 [2.835]
3	96 [3.780]	88 [3.465]
4	112 [4.409]	104 [4.094]
5	128 [5.039]	120 [4.724]
6	144 [5.669]	136 [5.354]
7	160 [6.299]	152 [5.984]
8	176 [6.929]	168 [6.614]
9	192 [7.559]	184 [7.244]
10	208 [8.189]	200 [7.874]
11	224 [8.819]	216 [8.504]
12	240 [9.449]	232 [9.134]
13	256 [10.079]	248 [9.764]
14	272 [10.709]	264 [10.394]
15	288 [11.339]	280 [11.024]
16	304 [11.969]	296 [11.654]
17	320 [12.599]	312 [12.283]
18	336 [13.228]	328 [12.913]
19	352 [13.858]	344 [13.543]
20	368 [14.488]	360 [14.173]

**F15M** Number of valves **AHL** Pilot specifications (Base piping type)

Monoblock manifold A type, wire saving type  
With manifold outlet port female thread block  
Dimensions show flat cable connector 20-pin specifications

● **Internal pilot specifications**

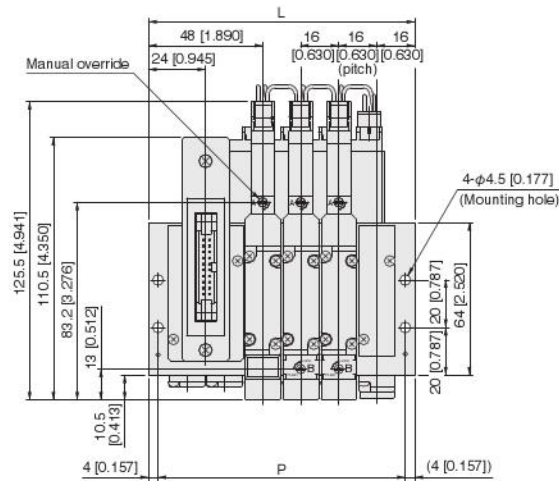
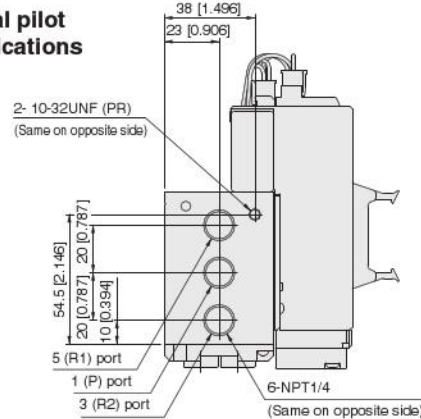

● **External pilot specifications**

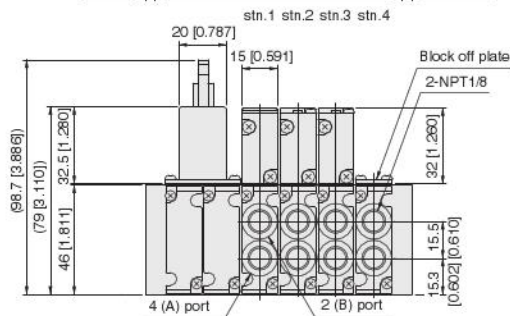
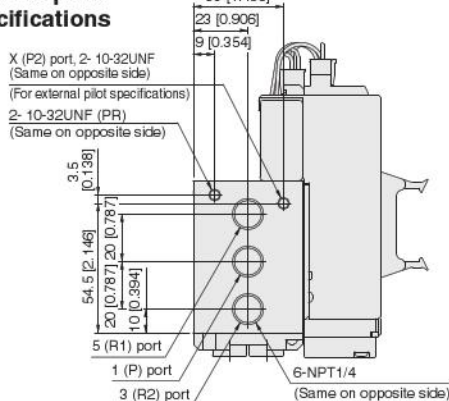

**Unit dimensions**

Number of units	L	P
2	80 [3.150]	72 [2.835]
3	96 [3.780]	88 [3.465]
4	112 [4.409]	104 [4.094]
5	128 [5.039]	120 [4.724]
6	144 [5.669]	136 [5.354]
7	160 [6.299]	152 [5.984]
8	176 [6.929]	168 [6.614]
9	192 [7.559]	184 [7.244]
10	208 [8.189]	200 [7.874]
11	224 [8.819]	216 [8.504]
12	240 [9.449]	232 [9.134]
13	256 [10.079]	248 [9.764]
14	272 [10.709]	264 [10.394]
15	288 [11.339]	280 [11.024]
16	304 [11.969]	296 [11.654]
17	320 [12.599]	312 [12.283]
18	336 [13.228]	328 [12.913]
19	352 [13.858]	344 [13.543]
20	368 [14.488]	360 [14.173]

**F15M** Number of valves **F** (Direct piping type)

Monoblock manifold F type, wire saving type  
 With valve outlet port dual use fitting block  
 Dimensions show flat cable connector 20-pin specifications

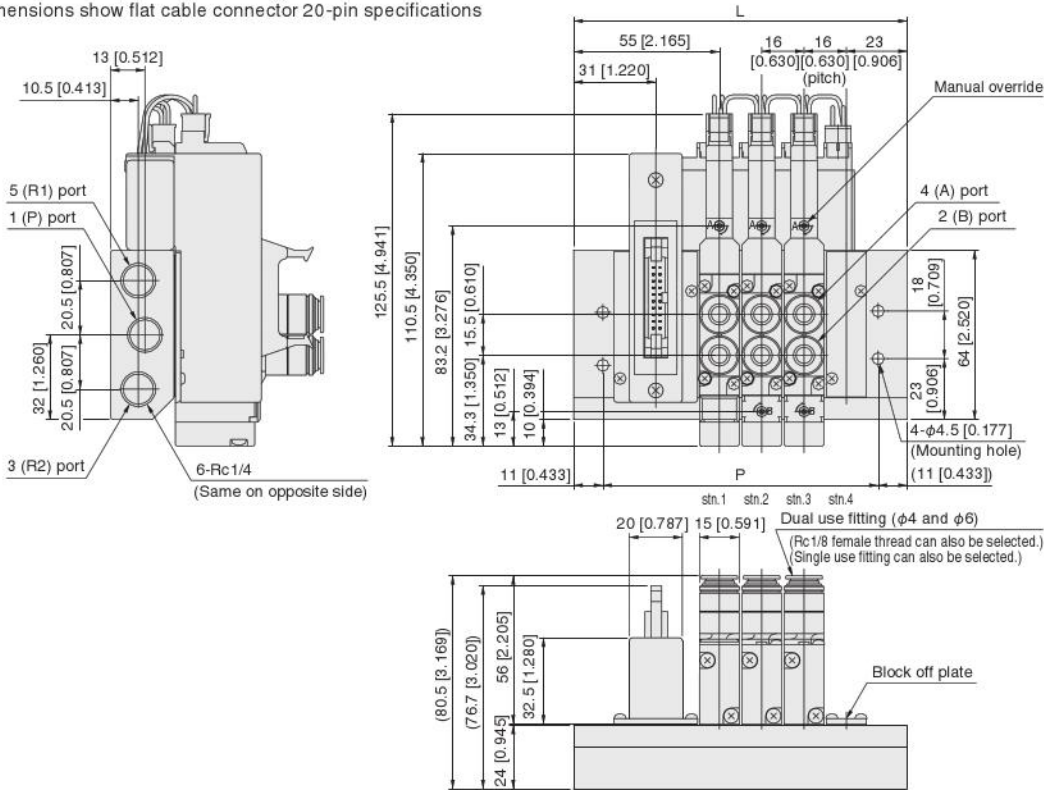

**Unit dimensions**

Number of units	L	P
2	94 [3.701]	72 [2.835]
3	110 [4.331]	88 [3.465]
4	126 [4.961]	104 [4.094]
5	142 [5.591]	120 [4.724]
6	158 [6.220]	136 [5.354]
7	174 [6.850]	152 [5.984]
8	190 [7.480]	168 [6.614]
9	206 [8.110]	184 [7.244]
10	222 [8.740]	200 [7.874]
11	238 [9.370]	216 [8.504]
12	254 [10.000]	232 [9.134]
13	270 [10.630]	248 [9.764]
14	286 [11.260]	264 [10.394]
15	302 [11.890]	280 [11.024]
16	318 [12.520]	296 [11.654]
17	334 [13.150]	312 [12.283]
18	350 [13.780]	328 [12.913]
19	366 [14.409]	344 [13.543]
20	382 [15.039]	360 [14.173]

**F15M** Number of valves **FH** (Direct piping type)

Monoblock manifold F type, wire saving type  
 With valve outlet port female thread block  
 Dimensions show flat cable connector 20-pin specifications

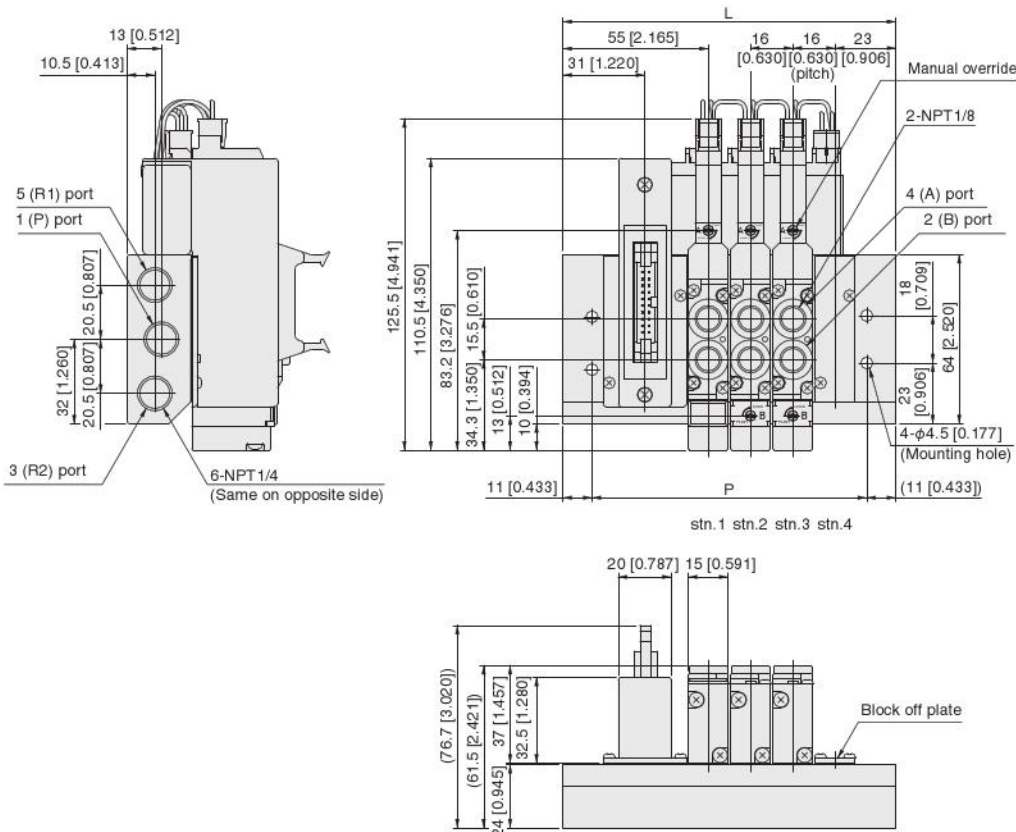

**Unit dimensions**

Number of units	L	P
2	94 [3.701]	72 [2.835]
3	110 [4.331]	88 [3.465]
4	126 [4.961]	104 [4.094]
5	142 [5.591]	120 [4.724]
6	158 [6.220]	136 [5.354]
7	174 [6.850]	152 [5.984]
8	190 [7.480]	168 [6.614]
9	206 [8.110]	184 [7.244]
10	222 [8.740]	200 [7.874]
11	238 [9.370]	216 [8.504]
12	254 [10.000]	232 [9.134]
13	270 [10.630]	248 [9.764]
14	286 [11.260]	264 [10.394]
15	302 [11.890]	280 [11.024]
16	318 [12.520]	296 [11.654]
17	334 [13.150]	312 [12.283]
18	350 [13.780]	328 [12.913]
19	366 [14.409]	344 [13.543]
20	382 [15.039]	360 [14.173]

F15 SERIES

**F15M** [Number of valves] **AP<sup>M</sup>** [Pilot specifications] (Base piping type)

PC board manifold A type  
With manifold outlet port dual use fitting block

Note: Mounted valve example shows -W wiring specifications.  
In the case of -S wiring specifications, the mounted valve becomes T0 or T1 type.

● **Internal pilot specifications**

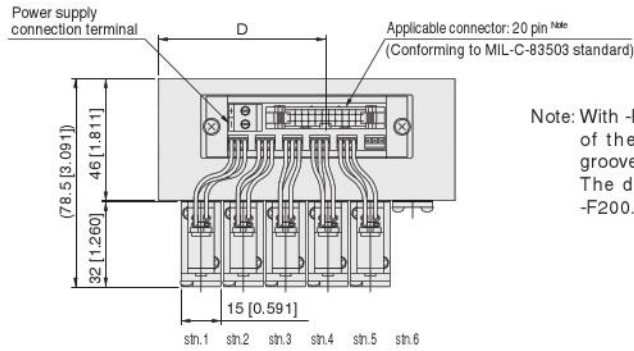
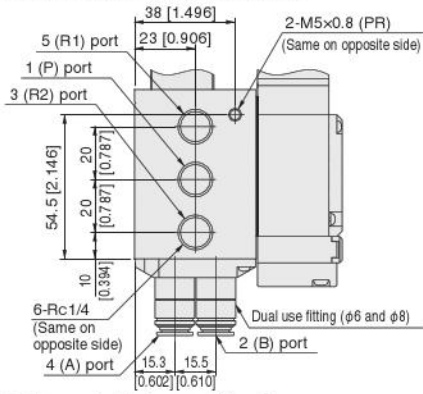

Note: With -F200 and -F201, the positions of the mis-insertion prevention grooves are reversed.  
The dimensions show the case of -F200.

● **External pilot specifications**

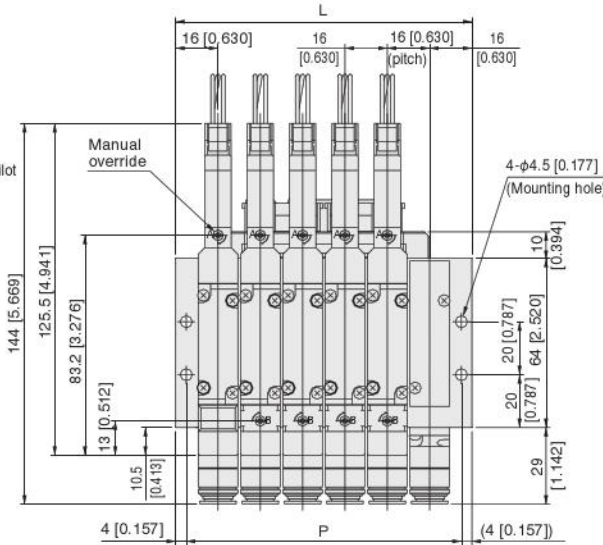
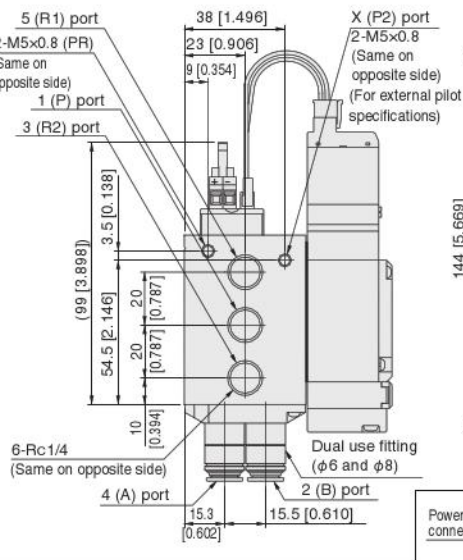

**Unit dimensions**

Number of units	L	P	D
6	112 [4.409]	104 [4.094]	63 [2.480]
8	144 [5.669]	136 [5.354]	68.5 [2.697]
10	176 [6.929]	168 [6.614]	68.5 [2.697]
12	208 [8.189]	200 [7.874]	79.5 [3.130]
14	240 [9.449]	232 [9.134]	90 [3.543]
16	272 [10.709]	264 [10.394]	90 [3.543]

Note: Wiring specifications  
For -S: 6, 8, 10, 12, 14, 16 units  
For -W: Only 6 and 8 units selectable

**F15M** [Number of valves] **FP** (Direct piping type)

PC board manifold F type  
With valve outlet port dual use fitting block

Note: Mounted valve example shows -W wiring specifications.  
In the case of -S wiring specifications, the mounted valve becomes T0 or T1 type.

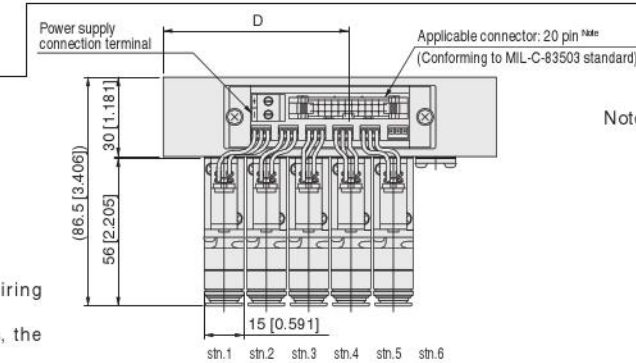
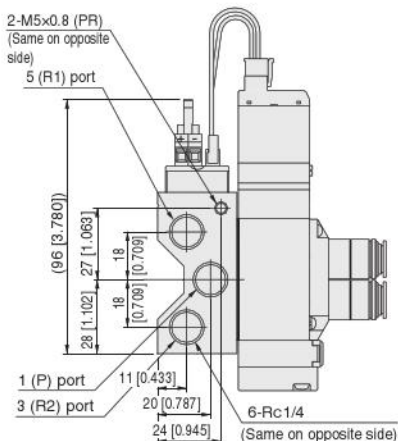

Note: With -F200 and -F201, the positions of the mis-insertion prevention grooves are reversed.  
The dimensions show the case of -F200.

**Unit dimensions**

Number of units	L	P	D
6	126 [4.961]	104 [4.094]	70 [2.756]
8	158 [6.220]	136 [5.354]	75.5 [2.972]
10	190 [7.480]	168 [6.614]	75.5 [2.972]
12	222 [8.740]	200 [7.874]	86.5 [3.406]
14	254 [10.000]	232 [9.134]	92 [3.622]
16	286 [11.260]	264 [10.394]	92 [3.622]

Note: Wiring specifications  
For -S: 6, 8, 10, 12, 14, 16 units  
For -W: Only 6 and 8 units selectable

# Dimensions of F15 series split manifold non-plug-in type mm [in]

## F15M Number of valves N M J Pilot specifications (Base piping type)

With manifold outlet port dual use fitting block  
S type plug connector

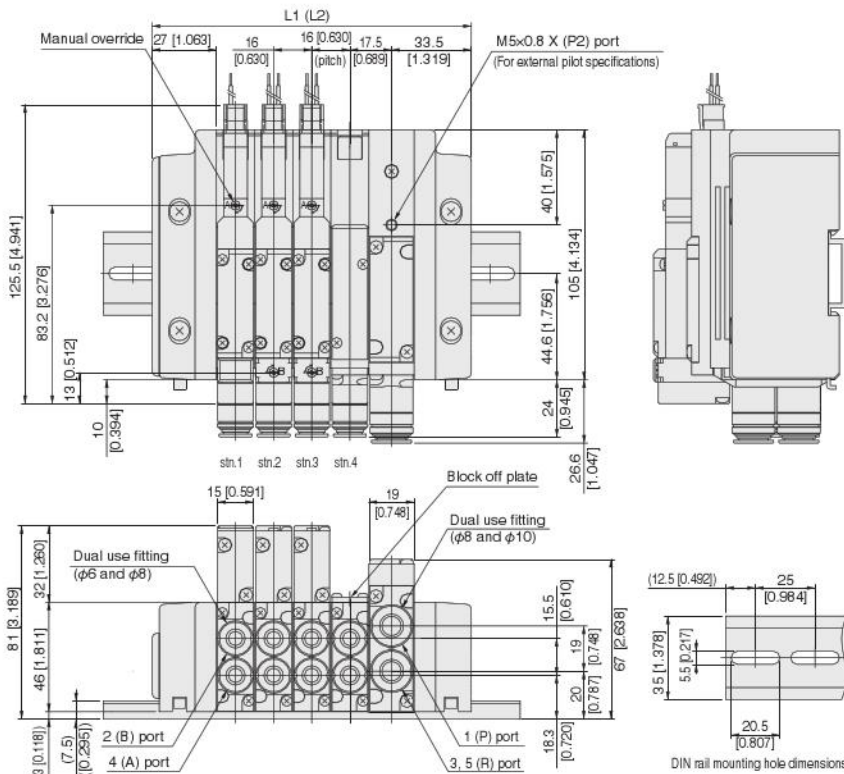

### Unit dimensions

Number of units	L1	Length of DIN rail	L2 <small>Note</small>	Length of DIN rail <small>Note</small>
2	102 [4.016]	150 [5.906]	121 [4.764]	150 [5.906]
3	118 [4.646]	150 [5.906]	137 [5.394]	175 [6.890]
4	134 [5.276]	175 [6.890]	153 [6.024]	200 [7.874]
5	150 [5.906]	175 [6.890]	169 [6.654]	200 [7.874]
6	166 [6.535]	200 [7.874]	185 [7.283]	225 [8.858]
7	182 [7.165]	225 [8.858]	201 [7.913]	250 [9.843]
8	198 [7.795]	225 [8.858]	217 [8.543]	250 [9.843]
9	214 [8.425]	250 [9.843]	233 [9.173]	275 [10.827]
10	230 [9.055]	275 [10.827]	249 [9.803]	275 [10.827]
11	246 [9.685]	275 [10.827]	265 [10.433]	300 [11.811]
12	262 [10.315]	300 [11.811]	281 [11.063]	325 [12.795]
13	278 [10.945]	325 [12.795]	297 [11.693]	325 [12.795]
14	294 [11.575]	325 [12.795]	313 [12.323]	350 [13.780]
15	310 [12.205]	350 [13.780]	329 [12.953]	375 [14.764]
16	326 [12.835]	375 [14.764]	345 [13.583]	375 [14.764]
17	342 [13.465]	375 [14.764]	361 [14.213]	400 [15.748]
18	358 [14.094]	400 [15.748]	377 [14.843]	425 [16.732]
19	374 [14.724]	400 [15.748]	393 [15.472]	425 [16.732]
20	390 [15.354]	425 [16.732]	409 [16.102]	450 [17.717]

Note: When two piping blocks are used.

## F15M Number of valves N Pilot specifications (Direct piping type)

With valve outlet port dual use fitting block  
S type plug connector

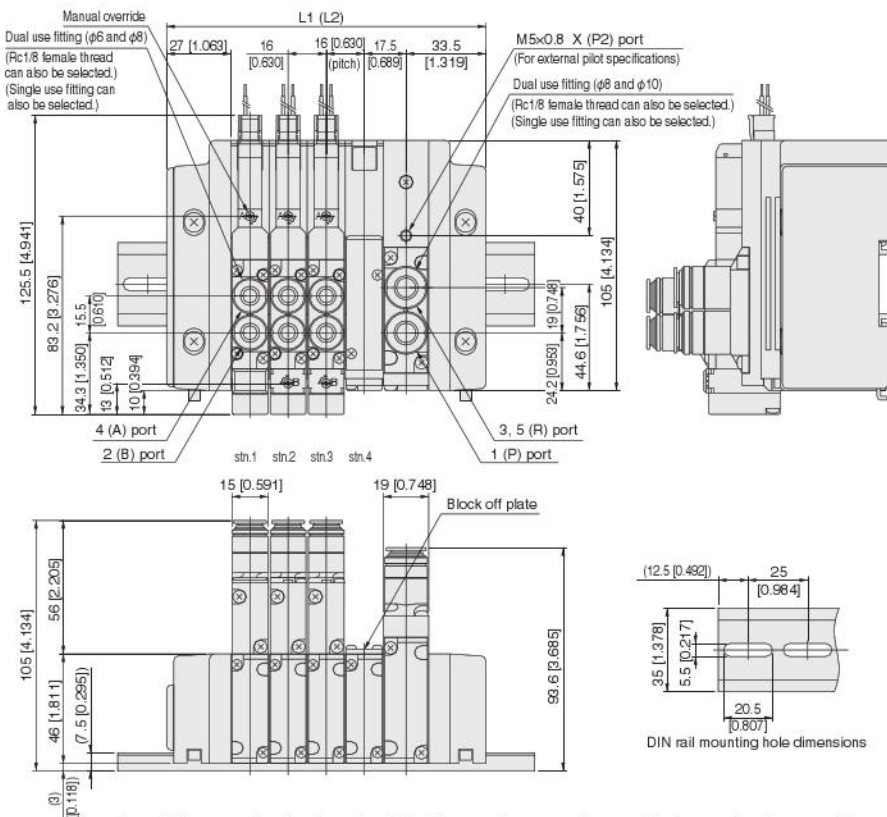

### Unit dimensions

Number of units	L1	Length of DIN rail	L2 <small>Note</small>	Length of DIN rail <small>Note</small>
2	102 [4.016]	150 [5.906]	121 [4.764]	150 [5.906]
3	118 [4.646]	150 [5.906]	137 [5.394]	175 [6.890]
4	134 [5.276]	175 [6.890]	153 [6.024]	200 [7.874]
5	150 [5.906]	175 [6.890]	169 [6.654]	200 [7.874]
6	166 [6.535]	200 [7.874]	185 [7.283]	225 [8.858]
7	182 [7.165]	225 [8.858]	201 [7.913]	250 [9.843]
8	198 [7.795]	225 [8.858]	217 [8.543]	250 [9.843]
9	214 [8.425]	250 [9.843]	233 [9.173]	275 [10.827]
10	230 [9.055]	275 [10.827]	249 [9.803]	275 [10.827]
11	246 [9.685]	275 [10.827]	265 [10.433]	300 [11.811]
12	262 [10.315]	300 [11.811]	281 [11.063]	325 [12.795]
13	278 [10.945]	325 [12.795]	297 [11.693]	325 [12.795]
14	294 [11.575]	325 [12.795]	313 [12.323]	350 [13.780]
15	310 [12.205]	350 [13.780]	329 [12.953]	375 [14.764]
16	326 [12.835]	375 [14.764]	345 [13.583]	375 [14.764]
17	342 [13.465]	375 [14.764]	361 [14.213]	400 [15.748]
18	358 [14.094]	400 [15.748]	377 [14.843]	425 [16.732]
19	374 [14.724]	400 [15.748]	393 [15.472]	425 [16.732]
20	390 [15.354]	425 [16.732]	409 [16.102]	450 [17.717]

Note: When two piping blocks are used.

Note: The overall valve length of the T0 type is 10 mm [0.394 in] shorter (end cover side protrusion is 10 mm [0.394 in] less).

**Dimensions of F15 series split manifold non-plug-in type** mm [in]

**F15M** Number of valves **NHL** Pilot specifications (Base piping type)

With manifold outlet port female thread block  
S type plug connector

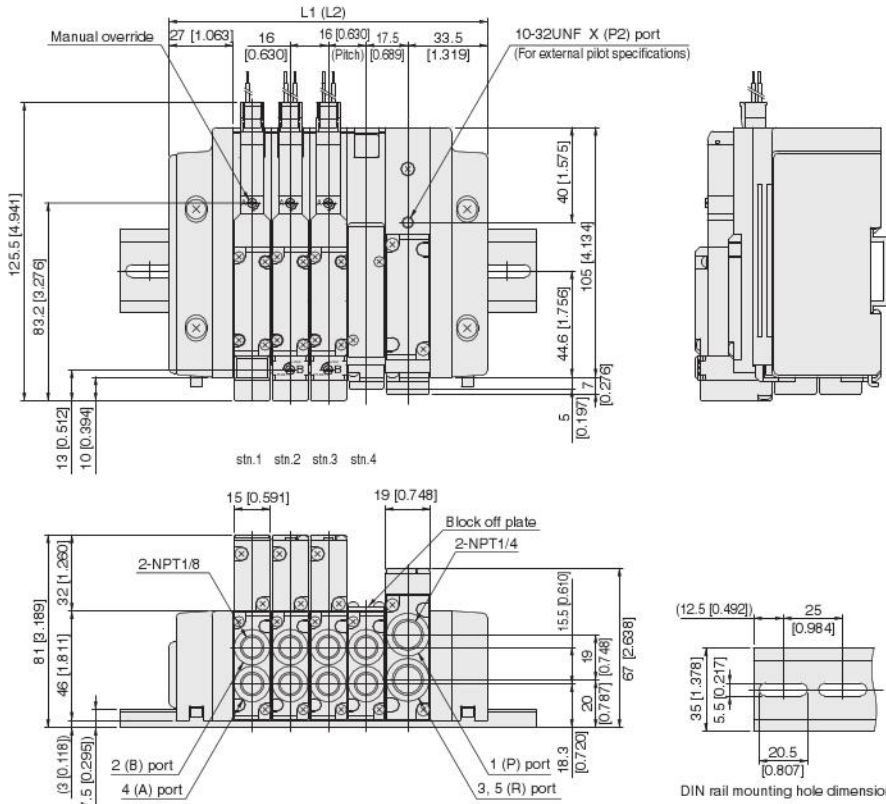

**Unit dimensions**

Number of units	L1	Length of DIN rail	L2 <small>NOTE</small>	Length of DIN rail <small>NOTE</small>
2	102 [4.016]	150 [5.906]	121 [4.764]	150 [5.906]
3	118 [4.646]	150 [5.906]	137 [5.394]	175 [6.890]
4	134 [5.276]	175 [6.890]	153 [6.024]	200 [7.874]
5	150 [5.906]	175 [6.890]	169 [6.654]	200 [7.874]
6	166 [6.535]	200 [7.874]	185 [7.283]	225 [8.858]
7	182 [7.165]	225 [8.858]	201 [7.913]	250 [9.843]
8	198 [7.795]	225 [8.858]	217 [8.543]	250 [9.843]
9	214 [8.425]	250 [9.843]	233 [9.173]	275 [10.827]
10	230 [9.055]	275 [10.827]	249 [9.803]	275 [10.827]
11	246 [9.685]	275 [10.827]	265 [10.433]	300 [11.811]
12	262 [10.315]	300 [11.811]	281 [11.063]	325 [12.795]
13	278 [10.945]	325 [12.795]	297 [11.693]	325 [12.795]
14	294 [11.575]	325 [12.795]	313 [12.323]	350 [13.780]
15	310 [12.205]	350 [13.780]	329 [12.953]	375 [14.764]
16	326 [12.835]	375 [14.764]	345 [13.583]	375 [14.764]
17	342 [13.465]	375 [14.764]	361 [14.213]	400 [15.748]
18	358 [14.094]	400 [15.748]	377 [14.843]	425 [16.732]
19	374 [14.724]	400 [15.748]	393 [15.472]	425 [16.732]
20	390 [15.354]	425 [16.732]	409 [16.102]	450 [17.717]

Note: When two piping blocks are used.

**F15M** Number of valves **NH** Pilot specifications (Direct piping type)

With valve outlet port female thread block  
S type plug connector

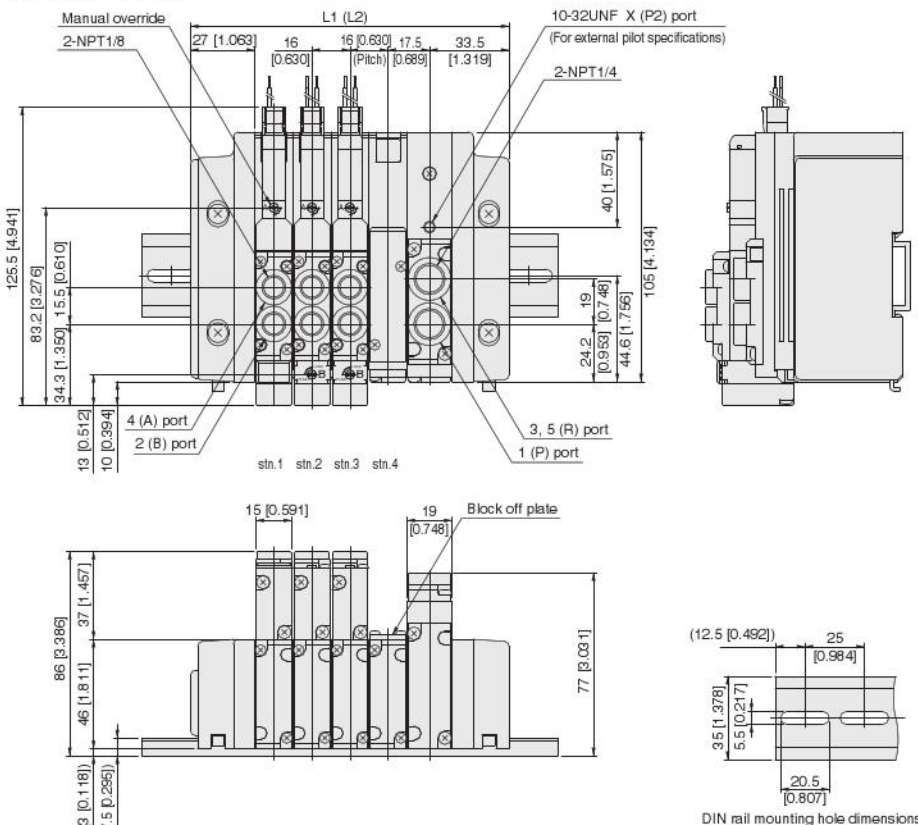

**Unit dimensions**

Number of units	L1	Length of DIN rail	L2 <small>NOTE</small>	Length of DIN rail <small>NOTE</small>
2	102 [4.016]	150 [5.906]	121 [4.764]	150 [5.906]
3	118 [4.646]	150 [5.906]	137 [5.394]	175 [6.890]
4	134 [5.276]	175 [6.890]	153 [6.024]	200 [7.874]
5	150 [5.906]	175 [6.890]	169 [6.654]	200 [7.874]
6	166 [6.535]	200 [7.874]	185 [7.283]	225 [8.858]
7	182 [7.165]	225 [8.858]	201 [7.913]	250 [9.843]
8	198 [7.795]	225 [8.858]	217 [8.543]	250 [9.843]
9	214 [8.425]	250 [9.843]	233 [9.173]	275 [10.827]
10	230 [9.055]	275 [10.827]	249 [9.803]	275 [10.827]
11	246 [9.685]	275 [10.827]	265 [10.433]	300 [11.811]
12	262 [10.315]	300 [11.811]	281 [11.063]	325 [12.795]
13	278 [10.945]	325 [12.795]	297 [11.693]	325 [12.795]
14	294 [11.575]	325 [12.795]	313 [12.323]	350 [13.780]
15	310 [12.205]	350 [13.780]	329 [12.953]	375 [14.764]
16	326 [12.835]	375 [14.764]	345 [13.583]	375 [14.764]
17	342 [13.465]	375 [14.764]	361 [14.213]	400 [15.748]
18	358 [14.094]	400 [15.748]	377 [14.843]	425 [16.732]
19	374 [14.724]	400 [15.748]	393 [15.472]	425 [16.732]
20	390 [15.354]	425 [16.732]	409 [16.102]	450 [17.717]

Note: When two piping blocks are used.

Note: The overall valve length of the T0 type is 10 mm [0.394 in] shorter (end cover side protrusion is 10 mm [0.394 in] less).

# Dimensions of F15 series split manifold plug-in type mm [in]

## F15M Number of valves P M Pilot specifications (Base piping type)

With manifold outlet port dual use fitting block  
Flat cable connector 10-pin specifications Manual override

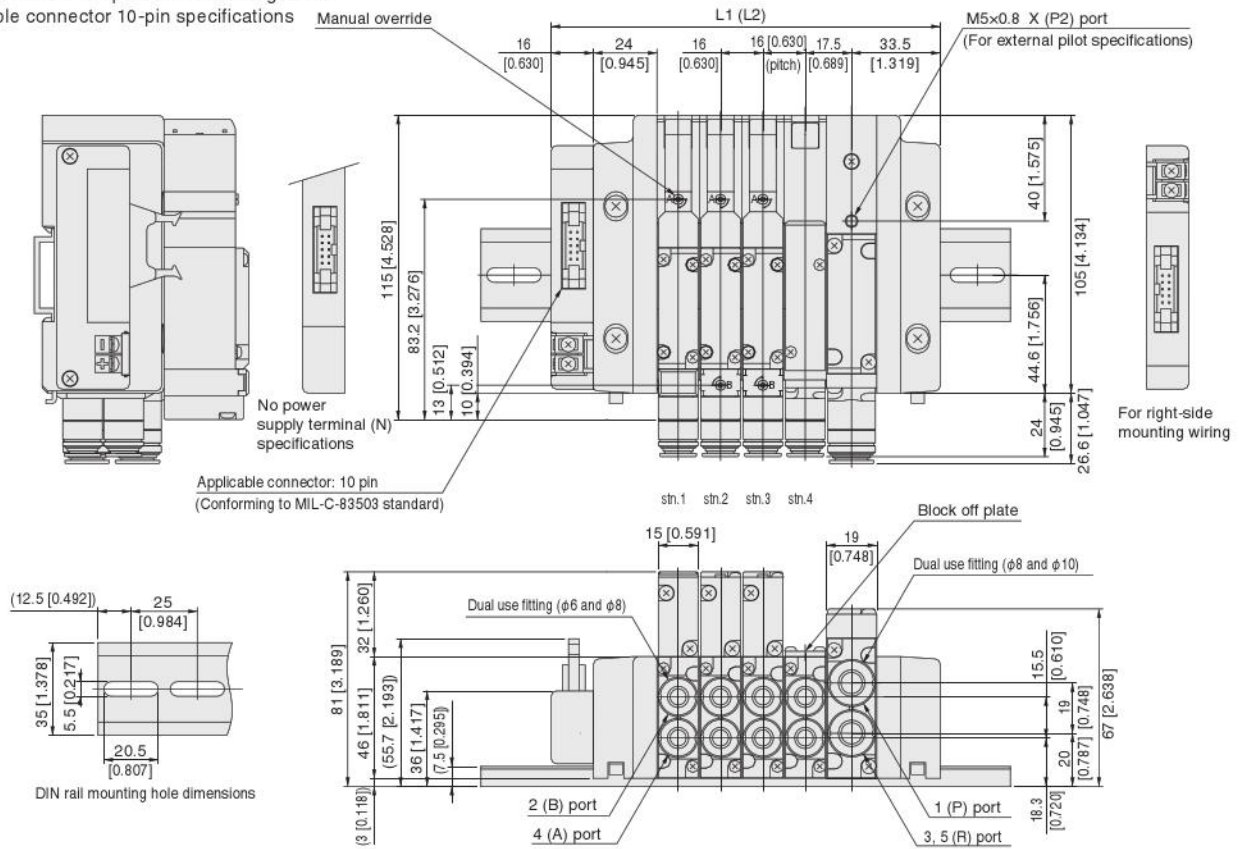

### Unit dimensions

Number of units	L1	Length of DIN rail	L2 <small>Notes</small>	Length of DIN rail <small>Notes</small>
2	115 [4.528]	150 [5.906]	134 [5.276]	175 [6.890]
3	131 [5.157]	175 [6.890]	150 [5.906]	200 [7.874]
4	147 [5.787]	200 [7.874]	166 [6.535]	200 [7.874]
5	163 [6.417]	200 [7.874]	182 [7.165]	225 [8.858]
6	179 [7.047]	225 [8.858]	198 [7.795]	250 [9.843]
7	195 [7.677]	250 [9.843]	214 [8.425]	250 [9.843]
8	211 [8.307]	250 [9.843]	230 [9.055]	275 [10.827]

Note: When two piping blocks are used.  
\* For right-side mounting wiring (-R), add 3 mm [0.118 in] to the L1 (L2) dimension.

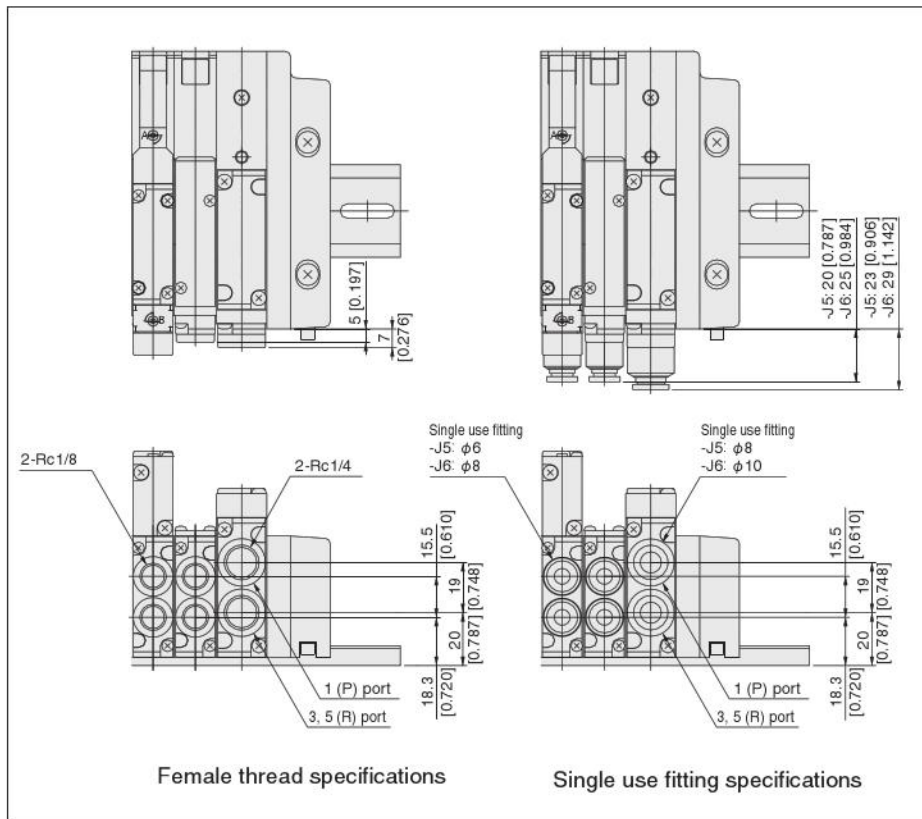

F15 SERIES

# Dimensions of F15 series split manifold plug-in type mm [in]

## F15M Number of valves P M L Pilot specifications (Base piping type)

With manifold outlet port dual use fitting block  
Flat cable connector 20-pin specifications (side surface wiring)

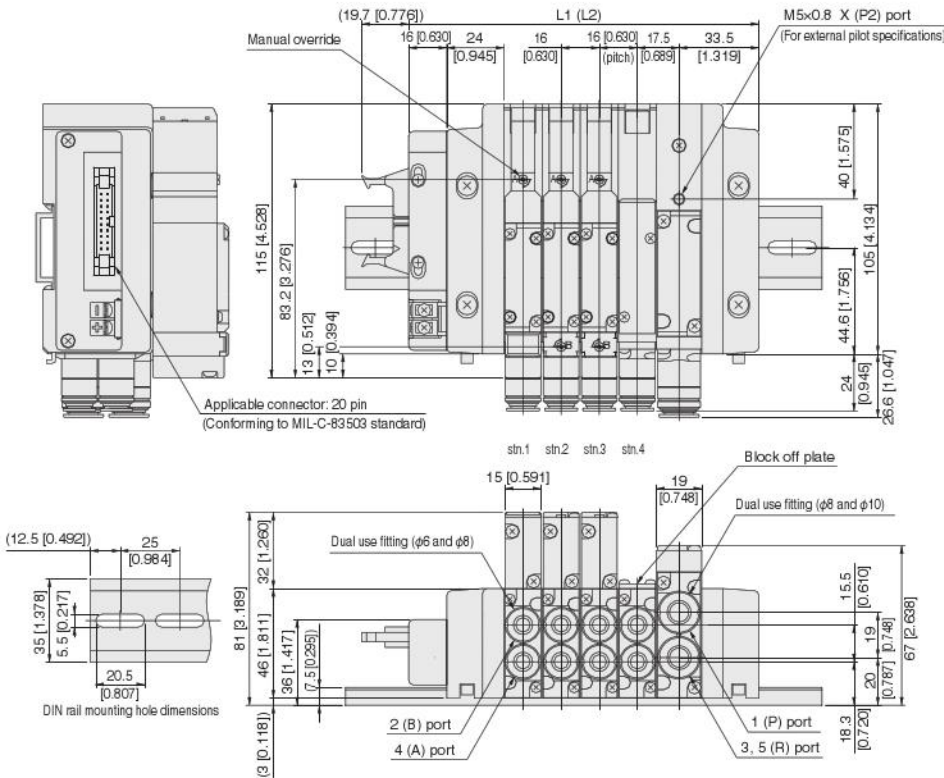

### Unit dimensions

Number of units	L1	Length of DIN rail	L2 <small>Note</small>	Length of DIN rail <small>Note</small>
2	115 [4.528]	150 [5.906]	134 [5.276]	175 [6.890]
3	131 [5.157]	175 [6.890]	150 [5.906]	200 [7.874]
4	147 [5.787]	200 [7.874]	166 [6.535]	200 [7.874]
5	163 [6.417]	200 [7.874]	182 [7.165]	225 [8.858]
6	179 [7.047]	225 [8.858]	198 [7.795]	250 [9.843]
7	195 [7.677]	250 [9.843]	214 [8.425]	250 [9.843]
8	211 [8.307]	250 [9.843]	230 [9.055]	275 [10.827]
9	227 [8.937]	275 [10.827]	246 [9.685]	300 [11.811]
10	243 [9.567]	300 [11.811]	262 [10.315]	300 [11.811]
11	259 [10.197]	300 [11.811]	278 [10.945]	325 [12.795]
12	275 [10.827]	325 [12.795]	294 [11.575]	350 [13.780]
13	291 [11.457]	325 [12.795]	310 [12.205]	350 [13.780]
14	307 [12.087]	350 [13.780]	326 [12.835]	375 [14.764]
15	323 [12.717]	375 [14.764]	342 [13.465]	375 [14.764]
16	339 [13.346]	375 [14.764]	358 [14.094]	400 [15.748]

Note: When two piping blocks are used.

\* For right-side mounting wiring (-R), add 3 mm [0.118 in] to the L1 (L2) dimension.

## F15M Number of valves P M L Pilot specifications (Base piping type)

With manifold outlet port dual use fitting block  
Flat cable connector 26-pin specifications

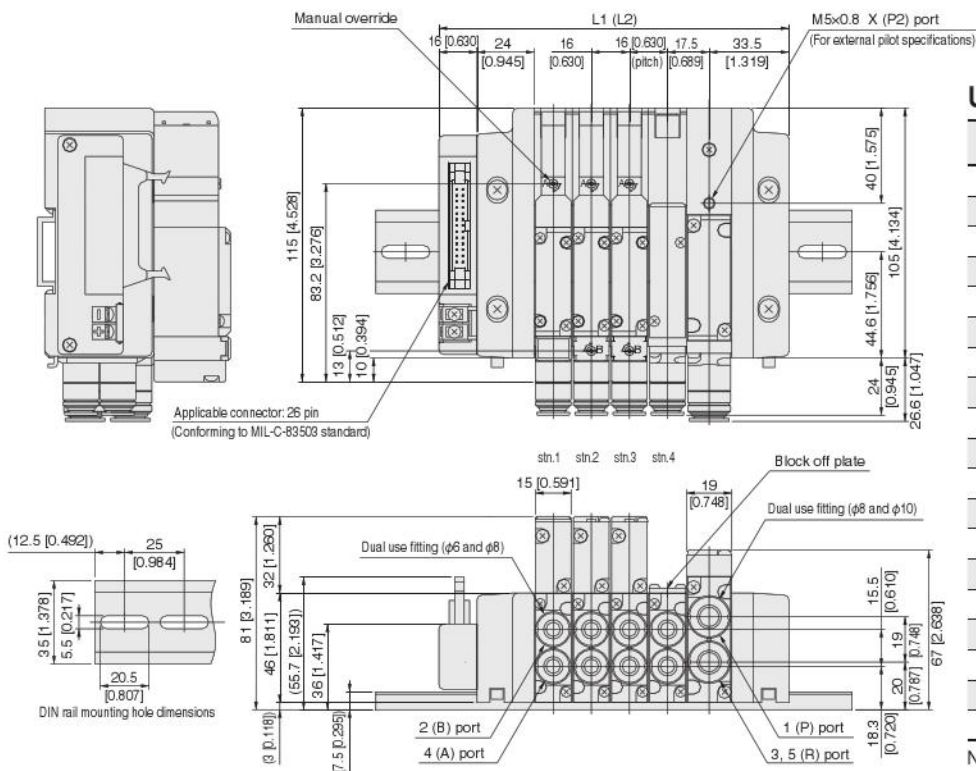

### Unit dimensions

Number of units	L1	Length of DIN rail	L2 <small>Note</small>	Length of DIN rail <small>Note</small>
2	115 [4.528]	150 [5.906]	134 [5.276]	175 [6.890]
3	131 [5.157]	175 [6.890]	150 [5.906]	200 [7.874]
4	147 [5.787]	200 [7.874]	166 [6.535]	200 [7.874]
5	163 [6.417]	200 [7.874]	182 [7.165]	225 [8.858]
6	179 [7.047]	225 [8.858]	198 [7.795]	250 [9.843]
7	195 [7.677]	250 [9.843]	214 [8.425]	250 [9.843]
8	211 [8.307]	250 [9.843]	230 [9.055]	275 [10.827]
9	227 [8.937]	275 [10.827]	246 [9.685]	300 [11.811]
10	243 [9.567]	300 [11.811]	262 [10.315]	300 [11.811]
11	259 [10.197]	300 [11.811]	278 [10.945]	325 [12.795]
12	275 [10.827]	325 [12.795]	294 [11.575]	350 [13.780]
13	291 [11.457]	325 [12.795]	310 [12.205]	350 [13.780]
14	307 [12.087]	350 [13.780]	326 [12.835]	375 [14.764]
15	323 [12.717]	375 [14.764]	342 [13.465]	375 [14.764]
16	339 [13.346]	375 [14.764]	358 [14.094]	400 [15.748]
17	355 [13.976]	400 [15.748]	374 [14.724]	425 [16.732]
18	371 [14.606]	425 [16.732]	390 [15.354]	425 [16.732]
19	387 [15.236]	425 [16.732]	406 [15.984]	450 [17.717]
20	403 [15.866]	450 [17.717]	422 [16.614]	475 [18.701]

Note: When two piping blocks are used.

\* For right-side mounting wiring (-R), add 3 mm [0.118 in] to the L1 (L2) dimension.

# Dimensions of F15 series split manifold plug-in type mm [in]

## F15M Number of valves P M L Pilot specifications (Base piping type)

With manifold outlet port dual use fitting block  
D-sub connector 25-pin specifications

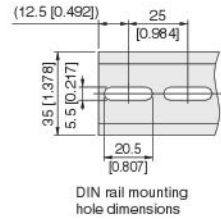

DIN rail mounting hole dimensions

### Unit dimensions

Number of units	L1	Length of DIN rail	L2 <small>Note</small>	Length of DIN rail <small>Note</small>
2	115 [4.528]	150 [5.906]	134 [5.276]	175 [6.890]
3	131 [5.157]	175 [6.890]	150 [5.906]	200 [7.874]
4	147 [5.787]	200 [7.874]	166 [6.535]	200 [7.874]
5	163 [6.417]	200 [7.874]	182 [7.165]	225 [8.858]
6	179 [7.047]	225 [8.858]	198 [7.795]	250 [9.843]
7	195 [7.677]	250 [9.843]	214 [8.425]	250 [9.843]
8	211 [8.307]	250 [9.843]	230 [9.055]	275 [10.827]
9	227 [8.937]	275 [10.827]	246 [9.685]	300 [11.811]
10	243 [9.567]	300 [11.811]	262 [10.315]	300 [11.811]
11	259 [10.197]	300 [11.811]	278 [10.945]	325 [12.795]
12	275 [10.827]	325 [12.795]	294 [11.575]	350 [13.780]
13	291 [11.457]	325 [12.795]	310 [12.205]	350 [13.780]
14	307 [12.087]	350 [13.780]	326 [12.835]	375 [14.764]
15	323 [12.717]	375 [14.764]	342 [13.465]	375 [14.764]
16	339 [13.346]	375 [14.764]	358 [14.094]	400 [15.748]
17	355 [13.976]	400 [15.748]	374 [14.724]	425 [16.732]
18	371 [14.606]	425 [16.732]	390 [15.354]	425 [16.732]
19	387 [15.236]	425 [16.732]	406 [15.984]	450 [17.717]
20	403 [15.866]	450 [17.717]	422 [16.614]	475 [18.701]

Note: When two piping blocks are used.

\* For right-side mounting wiring (-R), add 3 mm [0.118 in] to the L1 (L2) dimension.

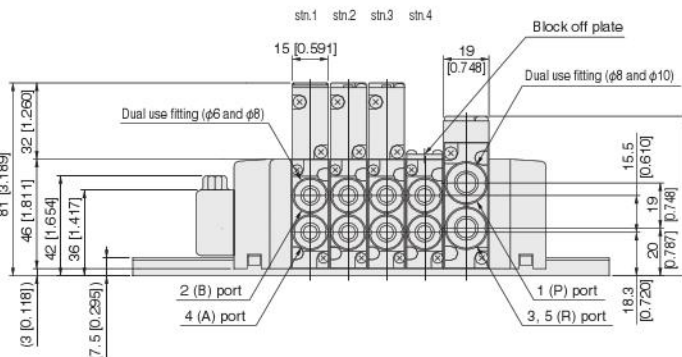
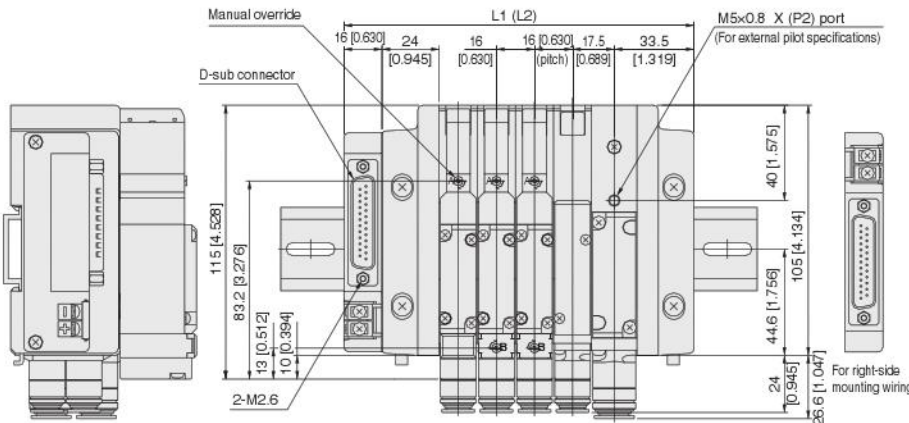

## F15M Number of valves P M L Pilot specifications (Base piping type)

With manifold outlet port dual use fitting block  
Terminal block type

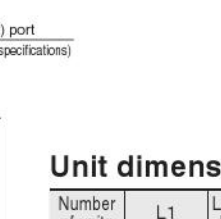

DIN rail mounting hole dimensions

### Unit dimensions

Number of units	L1	Length of DIN rail	L2 <small>Note</small>	Length of DIN rail <small>Note</small>
2	144 [5.669]	175 [6.890]	163 [6.417]	200 [7.874]
3	160 [6.299]	200 [7.874]	179 [7.047]	225 [8.858]
4	176 [6.929]	225 [8.858]	195 [7.677]	225 [8.858]
5	192 [7.559]	225 [8.858]	211 [8.307]	250 [9.843]
6	208 [8.189]	250 [9.843]	227 [8.937]	275 [10.827]
7	224 [8.819]	250 [9.843]	243 [9.567]	275 [10.827]
8	240 [9.449]	275 [10.827]	259 [10.197]	300 [11.811]
9	256 [10.079]	300 [11.811]	275 [10.827]	300 [11.811]
10	272 [10.709]	300 [11.811]	291 [11.457]	325 [12.795]
11	288 [11.339]	325 [12.795]	307 [12.087]	350 [13.780]
12	304 [11.969]	350 [13.780]	323 [12.717]	350 [13.780]
13	320 [12.599]	350 [13.780]	339 [13.346]	375 [14.764]
14	336 [13.228]	375 [14.764]	355 [13.976]	400 [15.748]
15	352 [13.858]	400 [15.748]	371 [14.606]	400 [15.748]
16	368 [14.488]	400 [15.748]	387 [15.236]	425 [16.732]
17	384 [15.118]	425 [16.732]	403 [15.866]	450 [17.717]
18	400 [15.748]	425 [16.732]	419 [16.496]	450 [17.717]

Note: When two piping blocks are used.

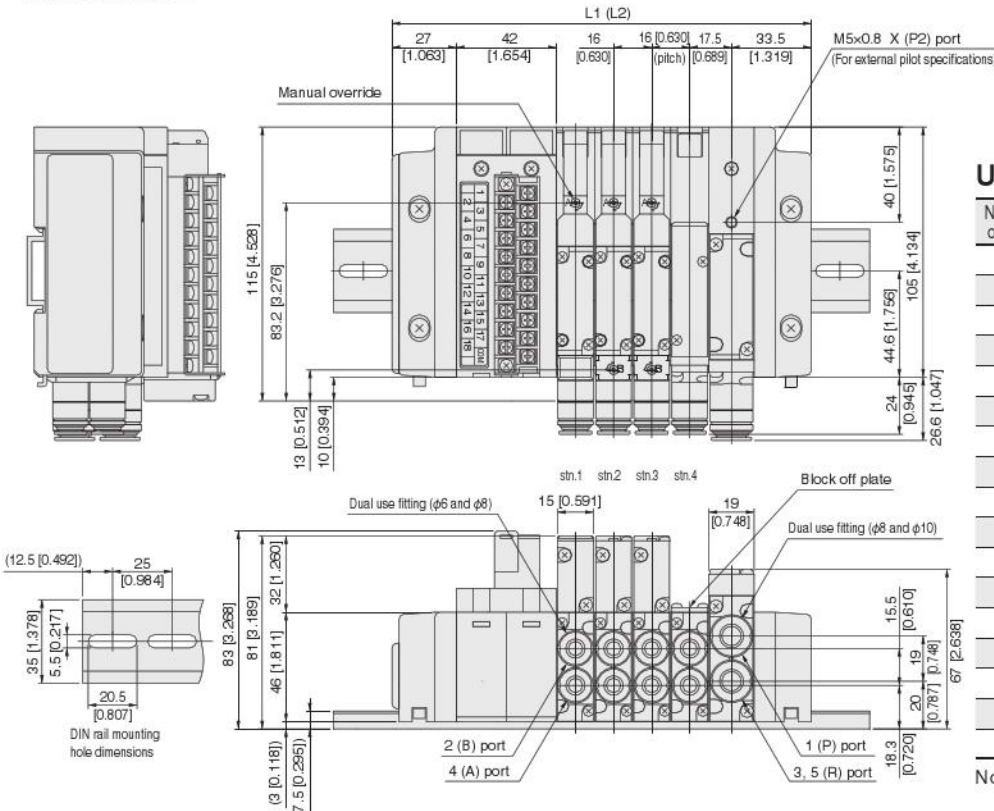

# Dimensions of F15 series split manifold plug-in type mm [in]

## F15M [Number of valves] PHL [Pilot specifications] (Base piping type)

With manifold outlet port female thread block  
Flat cable connector 10-pin specifications

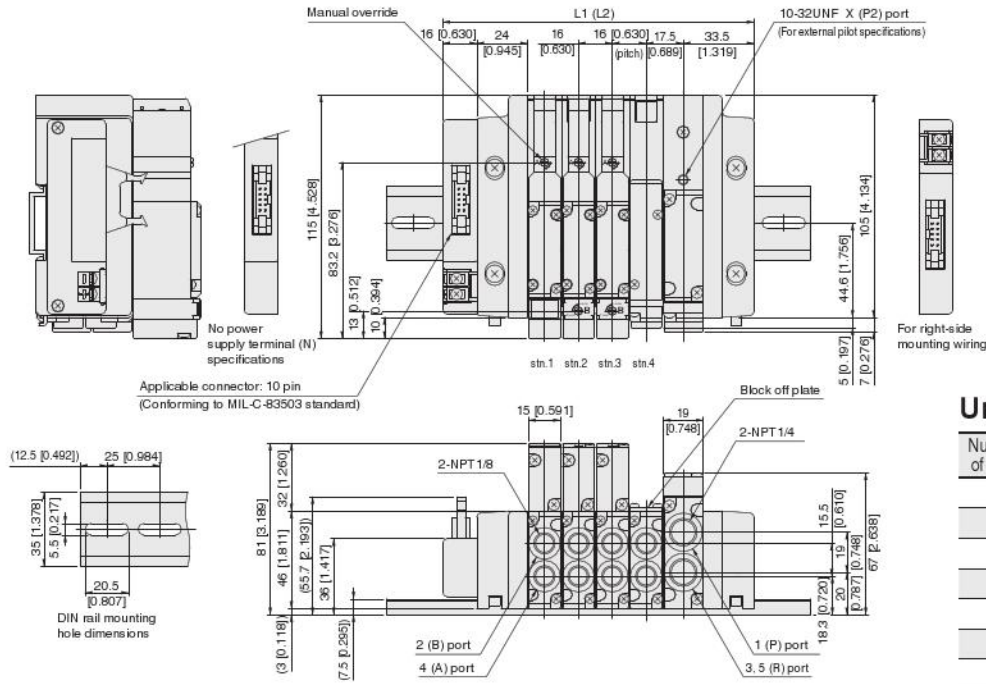

### Unit dimensions

Number of units	L1	Length of DIN rail	L2 <small>Note</small>	Length of DIN rail <small>Note</small>
2	115 [4.528]	150 [5.906]	134 [5.276]	175 [6.890]
3	131 [5.157]	175 [6.890]	150 [5.906]	200 [7.874]
4	147 [5.787]	200 [7.874]	166 [6.535]	200 [7.874]
5	163 [6.417]	200 [7.874]	182 [7.165]	225 [8.858]
6	179 [7.047]	225 [8.858]	198 [7.795]	250 [9.843]
7	195 [7.677]	250 [9.843]	214 [8.425]	250 [9.843]
8	211 [8.307]	250 [9.843]	230 [9.055]	275 [10.827]

Note: When two piping blocks are used.  
\* For right-side mounting wiring (-R), add 3 mm [0.118 in] to the L1 (L2) dimension.

## F15M [Number of valves] PH [Pilot specifications] (Direct piping type)

With valve outlet port female thread block  
Flat cable connector 10-pin specifications

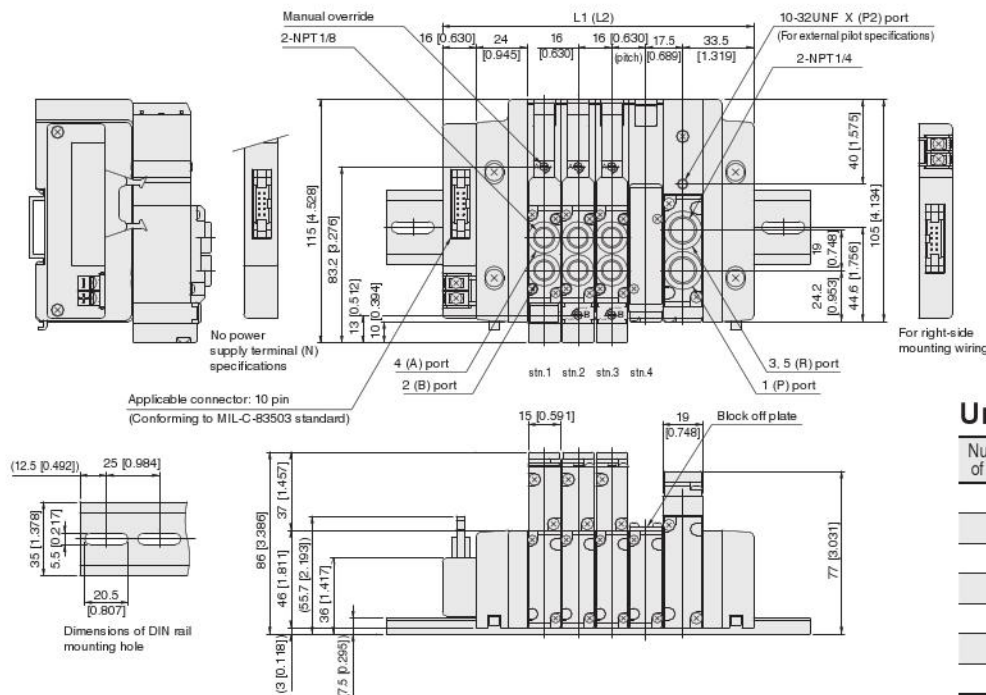

### Unit dimensions

Number of units	L1	Length of DIN rail	L2 <small>Note</small>	Length of DIN rail <small>Note</small>
2	115 [4.528]	150 [5.906]	134 [5.276]	175 [6.890]
3	131 [5.157]	175 [6.890]	150 [5.906]	200 [7.874]
4	147 [5.787]	200 [7.874]	166 [6.535]	200 [7.874]
5	163 [6.417]	200 [7.874]	182 [7.165]	225 [8.858]
6	179 [7.047]	225 [8.858]	198 [7.795]	250 [9.843]
7	195 [7.677]	250 [9.843]	214 [8.425]	250 [9.843]
8	211 [8.307]	250 [9.843]	230 [9.055]	275 [10.827]

Note: When two piping blocks are used.  
\* For right-side mounting wiring (-R), add 3 mm [0.118 in] to the L1 (L2) dimension.

# Dimensions of F15 series split manifold plug-in type mm [in]

## F15M Number of valves PHL Pilot specifications (Base piping type)

With manifold outlet port female thread block  
Flat cable connector 20-pin specifications (top surface wiring)

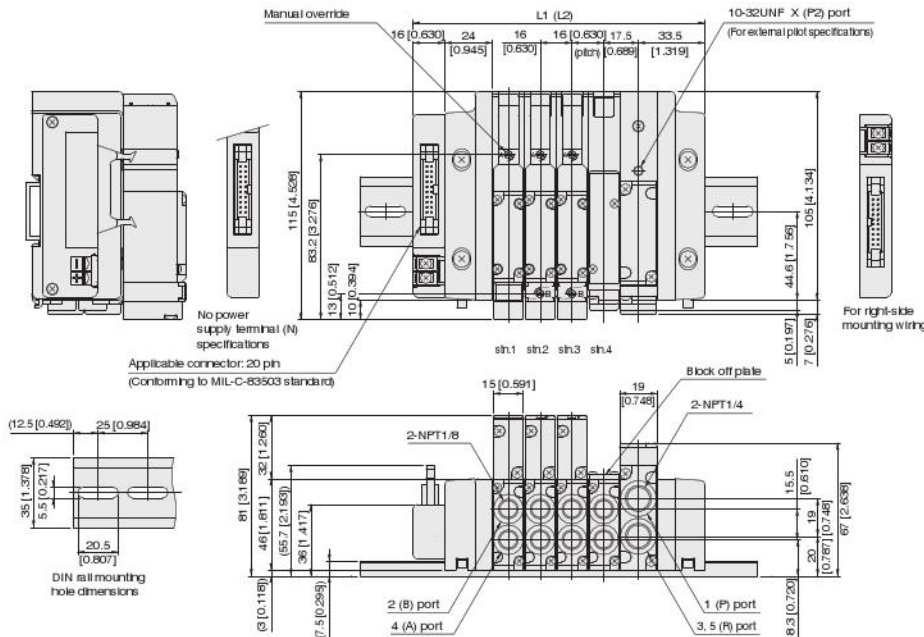

### Unit dimensions

Number of units	L1	Length of DIN rail	L2 <small>Note</small>	Length of DIN rail <small>Note</small>
2	115 [4.528]	150 [5.906]	134 [5.276]	175 [6.890]
3	131 [5.157]	175 [6.890]	150 [5.906]	200 [7.874]
4	147 [5.787]	200 [7.874]	166 [6.535]	200 [7.874]
5	163 [6.417]	200 [7.874]	182 [7.165]	225 [8.858]
6	179 [7.047]	225 [8.858]	198 [7.795]	250 [9.843]
7	195 [7.677]	250 [9.843]	214 [8.425]	250 [9.843]
8	211 [8.307]	250 [9.843]	230 [9.055]	275 [10.827]
9	227 [8.937]	275 [10.827]	246 [9.685]	300 [11.811]
10	243 [9.567]	300 [11.811]	262 [10.315]	300 [11.811]
11	259 [10.197]	300 [11.811]	278 [10.945]	325 [12.795]
12	275 [10.827]	325 [12.795]	294 [11.575]	350 [13.780]
13	291 [11.457]	325 [12.795]	310 [12.205]	350 [13.780]
14	307 [12.087]	350 [13.780]	326 [12.835]	375 [14.764]
15	323 [12.717]	375 [14.764]	342 [13.465]	375 [14.764]
16	339 [13.346]	375 [14.764]	358 [14.094]	400 [15.748]

Note: When two piping blocks are used.

\* For right-side mounting wiring (-R), add 3 mm [0.118 in] to the L1 (L2) dimension.

## F15M Number of valves PH Pilot specifications (Direct piping type)

With valve outlet port female thread block  
Flat cable connector 20-pin specifications (top surface wiring)

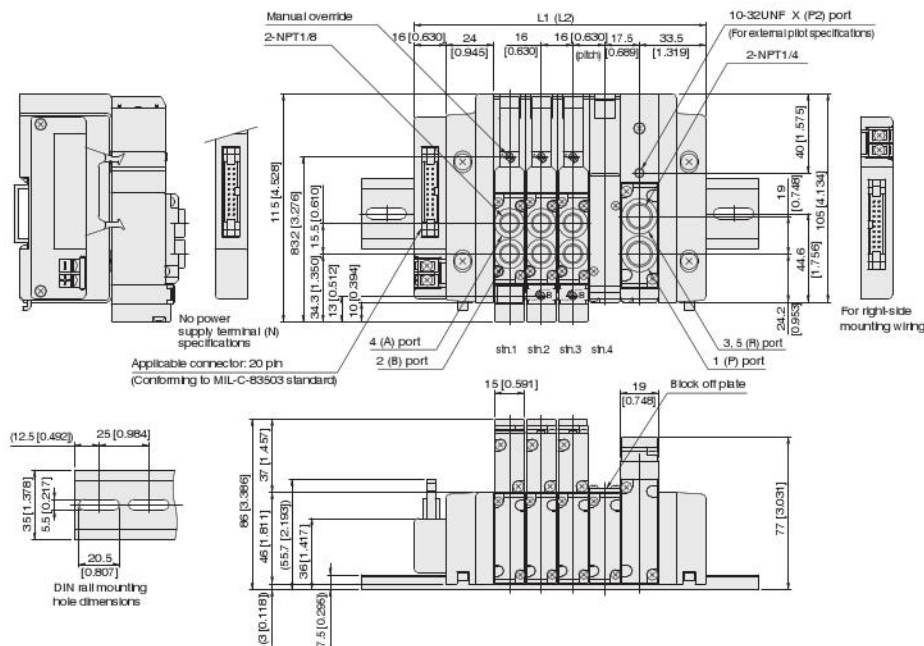

### Unit dimensions

Number of units	L1	Length of DIN rail	L2 <small>Note</small>	Length of DIN rail <small>Note</small>
2	115 [4.528]	150 [5.906]	134 [5.276]	175 [6.890]
3	131 [5.157]	175 [6.890]	150 [5.906]	200 [7.874]
4	147 [5.787]	200 [7.874]	166 [6.535]	200 [7.874]
5	163 [6.417]	200 [7.874]	182 [7.165]	225 [8.858]
6	179 [7.047]	225 [8.858]	198 [7.795]	250 [9.843]
7	195 [7.677]	250 [9.843]	214 [8.425]	250 [9.843]
8	211 [8.307]	250 [9.843]	230 [9.055]	275 [10.827]
9	227 [8.937]	275 [10.827]	246 [9.685]	300 [11.811]
10	243 [9.567]	300 [11.811]	262 [10.315]	300 [11.811]
11	259 [10.197]	300 [11.811]	278 [10.945]	325 [12.795]
12	275 [10.827]	325 [12.795]	294 [11.575]	350 [13.780]
13	291 [11.457]	325 [12.795]	310 [12.205]	350 [13.780]
14	307 [12.087]	350 [13.780]	326 [12.835]	375 [14.764]
15	323 [12.717]	375 [14.764]	342 [13.465]	375 [14.764]
16	339 [13.346]	375 [14.764]	358 [14.094]	400 [15.748]

Note: When two piping blocks are used.

\* For right-side mounting wiring (-R), add 3 mm [0.118 in] to the L1 (L2) dimension.

# Dimensions of F15 series split manifold plug-in type mm [in]

## F15M Number of valves PHL Pilot specifications (Base piping type)

With manifold outlet port female thread block  
Flat cable connector 26-pin specifications

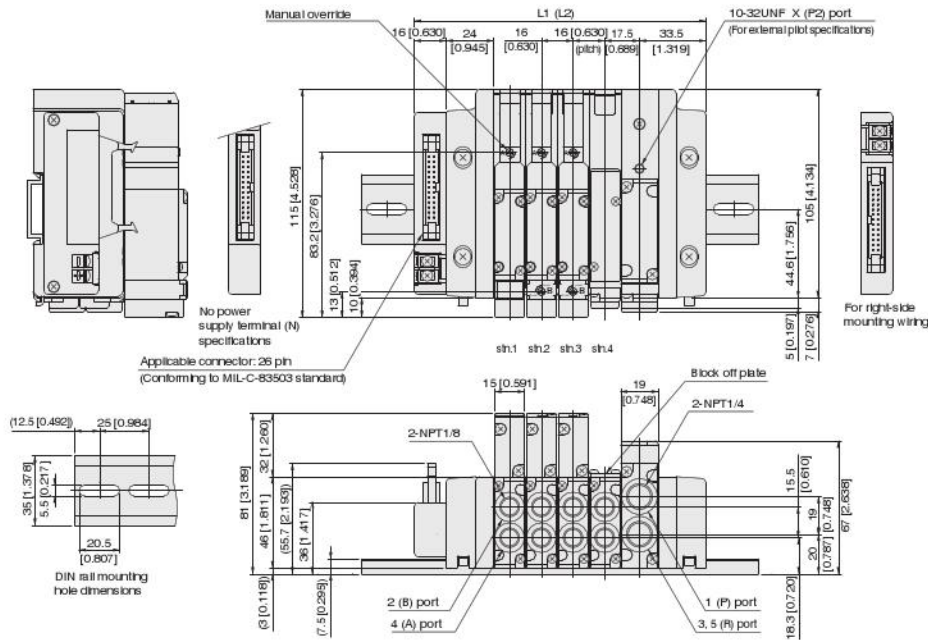

### Unit dimensions

Number of units	L1	Length of DIN rail	L2 <small>Note</small>	Length of DIN rail <small>Note</small>
2	115 [4.528]	150 [5.906]	134 [5.276]	175 [6.890]
3	131 [5.157]	175 [6.890]	150 [5.906]	200 [7.874]
4	147 [5.787]	200 [7.874]	166 [6.535]	200 [7.874]
5	163 [6.417]	200 [7.874]	182 [7.165]	225 [8.858]
6	179 [7.047]	225 [8.858]	198 [7.795]	250 [9.843]
7	195 [7.677]	250 [9.843]	214 [8.425]	250 [9.843]
8	211 [8.307]	250 [9.843]	230 [9.055]	275 [10.827]
9	227 [8.937]	275 [10.827]	246 [9.685]	300 [11.811]
10	243 [9.567]	300 [11.811]	262 [10.315]	300 [11.811]
11	259 [10.197]	300 [11.811]	278 [10.945]	325 [12.795]
12	275 [10.827]	325 [12.795]	294 [11.575]	350 [13.780]
13	291 [11.457]	325 [12.795]	310 [12.205]	350 [13.780]
14	307 [12.087]	350 [13.780]	326 [12.835]	375 [14.764]
15	323 [12.717]	375 [14.764]	342 [13.465]	375 [14.764]
16	339 [13.346]	375 [14.764]	358 [14.094]	400 [15.748]
17	355 [13.976]	400 [15.748]	374 [14.724]	425 [16.732]
18	371 [14.606]	425 [16.732]	390 [15.354]	425 [16.732]
19	387 [15.236]	425 [16.732]	406 [15.984]	450 [17.717]
20	403 [15.866]	450 [17.717]	422 [16.614]	475 [18.701]

Note: When two piping blocks are used.

\* For right-side mounting wiring (-R), add 3 mm [0.118 in] to the L1 (L2) dimension.

## F15M Number of valves PH Pilot specifications (Direct piping type)

With valve outlet port female thread block  
Flat cable connector 26-pin specifications

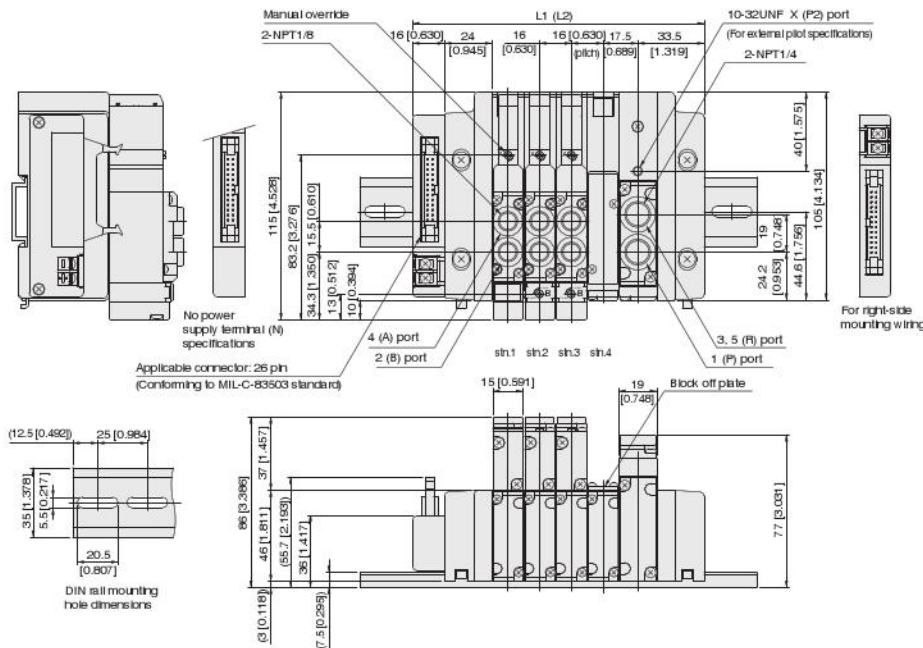

### Unit dimensions

Number of units	L1	Length of DIN rail	L2 <small>Note</small>	Length of DIN rail <small>Note</small>
2	115 [4.528]	150 [5.906]	134 [5.276]	175 [6.890]
3	131 [5.157]	175 [6.890]	150 [5.906]	200 [7.874]
4	147 [5.787]	200 [7.874]	166 [6.535]	200 [7.874]
5	163 [6.417]	200 [7.874]	182 [7.165]	225 [8.858]
6	179 [7.047]	225 [8.858]	198 [7.795]	250 [9.843]
7	195 [7.677]	250 [9.843]	214 [8.425]	250 [9.843]
8	211 [8.307]	250 [9.843]	230 [9.055]	275 [10.827]
9	227 [8.937]	275 [10.827]	246 [9.685]	300 [11.811]
10	243 [9.567]	300 [11.811]	262 [10.315]	300 [11.811]
11	259 [10.197]	300 [11.811]	278 [10.945]	325 [12.795]
12	275 [10.827]	325 [12.795]	294 [11.575]	350 [13.780]
13	291 [11.457]	325 [12.795]	310 [12.205]	350 [13.780]
14	307 [12.087]	350 [13.780]	326 [12.835]	375 [14.764]
15	323 [12.717]	375 [14.764]	342 [13.465]	375 [14.764]
16	339 [13.346]	375 [14.764]	358 [14.094]	400 [15.748]
17	355 [13.976]	400 [15.748]	374 [14.724]	425 [16.732]
18	371 [14.606]	425 [16.732]	390 [15.354]	425 [16.732]
19	387 [15.236]	425 [16.732]	406 [15.984]	450 [17.717]
20	403 [15.866]	450 [17.717]	422 [16.614]	475 [18.701]

Note: When two piping blocks are used.

\* For right-side mounting wiring (-R), add 3 mm [0.118 in] to the L1 (L2) dimension.

# Dimensions of F15 series split manifold plug-in type mm [in]

## F15M Number of valves PHL Pilot specifications (Base piping type)

With manifold outlet port female thread block  
D-sub connector 25-pin specifications

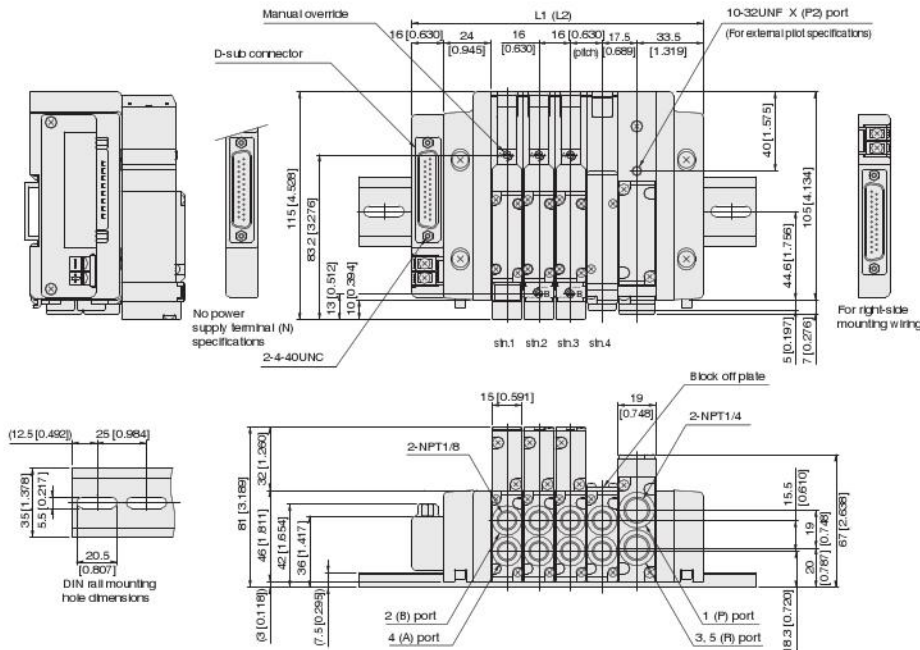

### Unit dimensions

Number of units	L1	Length of DIN rail	L2 <small>Note</small>	Length of DIN rail <small>Note</small>
2	115 [4.528]	150 [5.906]	134 [5.276]	175 [6.890]
3	131 [5.157]	175 [6.890]	150 [5.906]	200 [7.874]
4	147 [5.787]	200 [7.874]	166 [6.535]	200 [7.874]
5	163 [6.417]	200 [7.874]	182 [7.165]	225 [8.858]
6	179 [7.047]	225 [8.858]	198 [7.795]	250 [9.843]
7	195 [7.677]	250 [9.843]	214 [8.425]	250 [9.843]
8	211 [8.307]	250 [9.843]	230 [9.055]	275 [10.827]
9	227 [8.937]	275 [10.827]	246 [9.685]	300 [11.811]
10	243 [9.567]	300 [11.811]	262 [10.315]	300 [11.811]
11	259 [10.197]	300 [11.811]	278 [10.945]	325 [12.795]
12	275 [10.827]	325 [12.795]	294 [11.575]	350 [13.780]
13	291 [11.457]	325 [12.795]	310 [12.205]	350 [13.780]
14	307 [12.087]	350 [13.780]	326 [12.835]	375 [14.764]
15	323 [12.717]	375 [14.764]	342 [13.465]	375 [14.764]
16	339 [13.346]	375 [14.764]	358 [14.094]	400 [15.748]
17	355 [13.976]	400 [15.748]	374 [14.724]	425 [16.732]
18	371 [14.606]	425 [16.732]	390 [15.354]	425 [16.732]
19	387 [15.236]	425 [16.732]	406 [15.984]	450 [17.717]
20	403 [15.866]	450 [17.717]	422 [16.614]	475 [18.701]

Note: When two piping blocks are used.

\* For right-side mounting wiring (-R), add 3 mm [0.118 in] to the L1 (L2) dimension.

## F15M Number of valves PH Pilot specifications (Direct piping type)

With valve outlet port female thread block  
D-sub connector 25-pin specifications

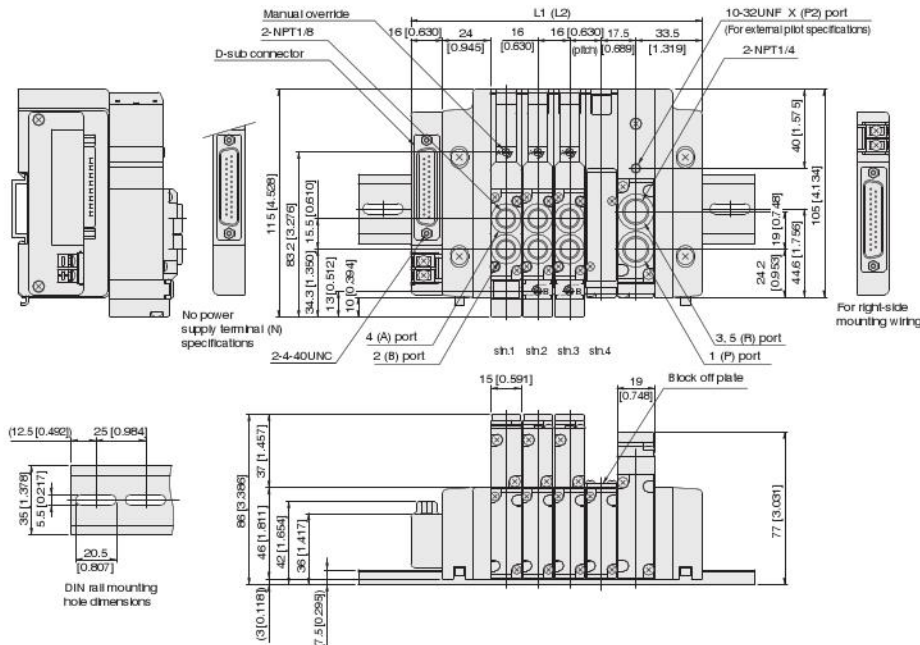

### Unit dimensions

Number of units	L1	Length of DIN rail	L2 <small>Note</small>	Length of DIN rail <small>Note</small>
2	115 [4.528]	150 [5.906]	134 [5.276]	175 [6.890]
3	131 [5.157]	175 [6.890]	150 [5.906]	200 [7.874]
4	147 [5.787]	200 [7.874]	166 [6.535]	200 [7.874]
5	163 [6.417]	200 [7.874]	182 [7.165]	225 [8.858]
6	179 [7.047]	225 [8.858]	198 [7.795]	250 [9.843]
7	195 [7.677]	250 [9.843]	214 [8.425]	250 [9.843]
8	211 [8.307]	250 [9.843]	230 [9.055]	275 [10.827]
9	227 [8.937]	275 [10.827]	246 [9.685]	300 [11.811]
10	243 [9.567]	300 [11.811]	262 [10.315]	300 [11.811]
11	259 [10.197]	300 [11.811]	278 [10.945]	325 [12.795]
12	275 [10.827]	325 [12.795]	294 [11.575]	350 [13.780]
13	291 [11.457]	325 [12.795]	310 [12.205]	350 [13.780]
14	307 [12.087]	350 [13.780]	326 [12.835]	375 [14.764]
15	323 [12.717]	375 [14.764]	342 [13.465]	375 [14.764]
16	339 [13.346]	375 [14.764]	358 [14.094]	400 [15.748]
17	355 [13.976]	400 [15.748]	374 [14.724]	425 [16.732]
18	371 [14.606]	425 [16.732]	390 [15.354]	425 [16.732]
19	387 [15.236]	425 [16.732]	406 [15.984]	450 [17.717]
20	403 [15.866]	450 [17.717]	422 [16.614]	475 [18.701]

Note: When two piping blocks are used.

\* For right-side mounting wiring (-R), add 3 mm [0.118 in] to the L1 (L2) dimension.

# Dimensions of F15 series split manifold plug-in type mm [in]

## F15M Number of valves PHL Pilot specifications (Base piping type)

With manifold outlet port female thread block  
D-sub connector 37-pin specifications

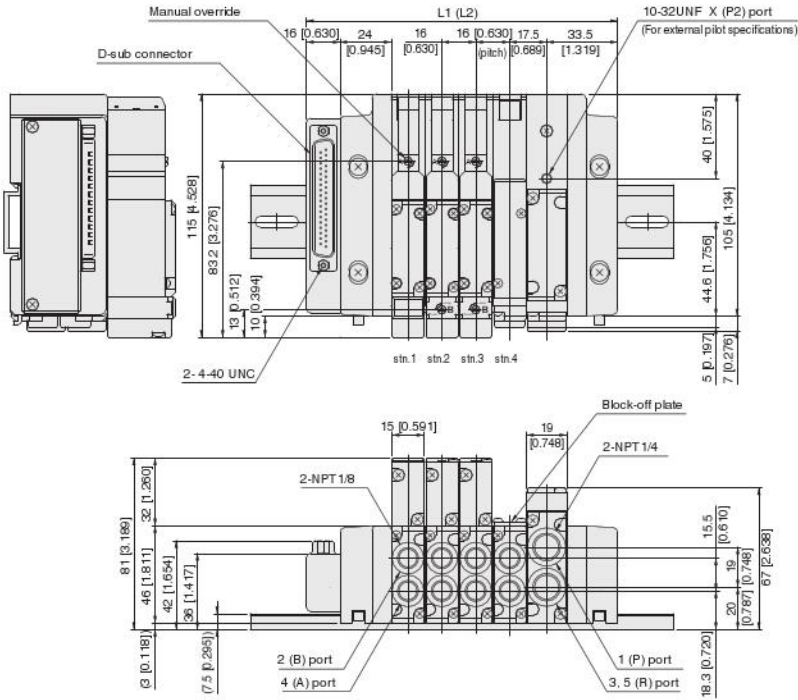

### Unit dimensions

Number of units	L1	Length of DIN rail	L2 <small>Note</small>	Length of DIN rail <small>Note</small>
2	115 [4.528]	150 [5.906]	134 [5.276]	175 [6.890]
3	131 [5.157]	175 [6.890]	150 [5.906]	200 [7.874]
4	147 [5.787]	200 [7.874]	166 [6.535]	200 [7.874]
5	163 [6.417]	200 [7.874]	182 [7.165]	225 [8.858]
6	179 [7.047]	225 [8.858]	198 [7.795]	250 [9.843]
7	195 [7.677]	250 [9.843]	214 [8.425]	250 [9.843]
8	211 [8.307]	250 [9.843]	230 [9.055]	275 [10.827]
9	227 [8.937]	275 [10.827]	246 [9.685]	300 [11.811]
10	243 [9.567]	300 [11.811]	262 [10.315]	300 [11.811]
11	259 [10.197]	300 [11.811]	278 [10.945]	325 [12.795]
12	275 [10.827]	325 [12.795]	294 [11.575]	350 [13.780]
13	291 [11.457]	325 [12.795]	310 [12.205]	350 [13.780]
14	307 [12.087]	350 [13.780]	326 [12.835]	375 [14.764]
15	323 [12.717]	375 [14.764]	342 [13.465]	375 [14.764]
16	339 [13.346]	375 [14.764]	358 [14.094]	400 [15.748]
17	355 [13.976]	400 [15.748]	374 [14.724]	425 [16.732]
18	371 [14.606]	425 [16.732]	390 [15.354]	425 [16.732]
19	387 [15.236]	425 [16.732]	406 [15.984]	450 [17.717]
20	403 [15.866]	450 [17.717]	422 [16.614]	475 [18.701]

Note: When two piping blocks are used.

\* For right-side mounting wiring (-R), add 3 mm [0.118 in] to the L1 (L2) dimension.

## F15M Number of valves PH Pilot specifications (Base piping type)

With valve outlet port female thread block  
D-sub connector 37-pin specifications

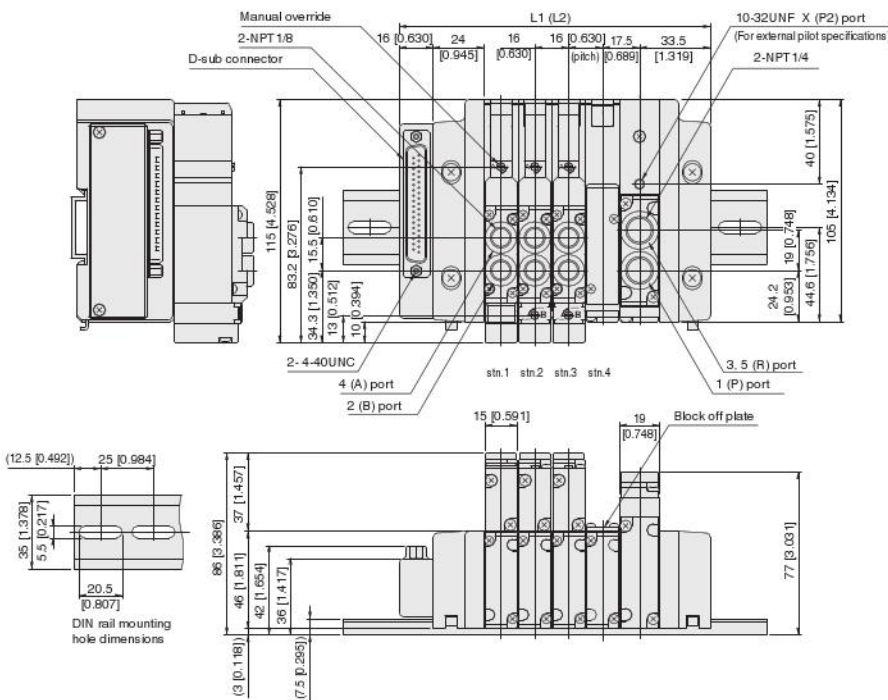

### Unit dimensions

Number of units	L1	Length of DIN rail	L2 <small>Note</small>	Length of DIN rail <small>Note</small>
2	115 [4.528]	150 [5.906]	134 [5.276]	175 [6.890]
3	131 [5.157]	175 [6.890]	150 [5.906]	200 [7.874]
4	147 [5.787]	200 [7.874]	166 [6.535]	200 [7.874]
5	163 [6.417]	200 [7.874]	182 [7.165]	225 [8.858]
6	179 [7.047]	225 [8.858]	198 [7.795]	250 [9.843]
7	195 [7.677]	250 [9.843]	214 [8.425]	250 [9.843]
8	211 [8.307]	250 [9.843]	230 [9.055]	275 [10.827]
9	227 [8.937]	275 [10.827]	246 [9.685]	300 [11.811]
10	243 [9.567]	300 [11.811]	262 [10.315]	300 [11.811]
11	259 [10.197]	300 [11.811]	278 [10.945]	325 [12.795]
12	275 [10.827]	325 [12.795]	294 [11.575]	350 [13.780]
13	291 [11.457]	325 [12.795]	310 [12.205]	350 [13.780]
14	307 [12.087]	350 [13.780]	326 [12.835]	375 [14.764]
15	323 [12.717]	375 [14.764]	342 [13.465]	375 [14.764]
16	339 [13.346]	375 [14.764]	358 [14.094]	400 [15.748]
17	355 [13.976]	400 [15.748]	374 [14.724]	425 [16.732]
18	371 [14.606]	425 [16.732]	390 [15.354]	425 [16.732]
19	387 [15.236]	425 [16.732]	406 [15.984]	450 [17.717]
20	403 [15.866]	450 [17.717]	422 [16.614]	475 [18.701]

Note: When two piping blocks are used.

\* For right-side mounting wiring (-R), add 3 mm [0.118 in] to the L1 (L2) dimension.



# Dimensions of F15 series serial transmission compatible manifold mm [In]

## F15M Number of valves S M J Pilot specifications (Base piping type)

With manifold outlet port dual use fitting block  
(Models that support integrated serial transmission block)

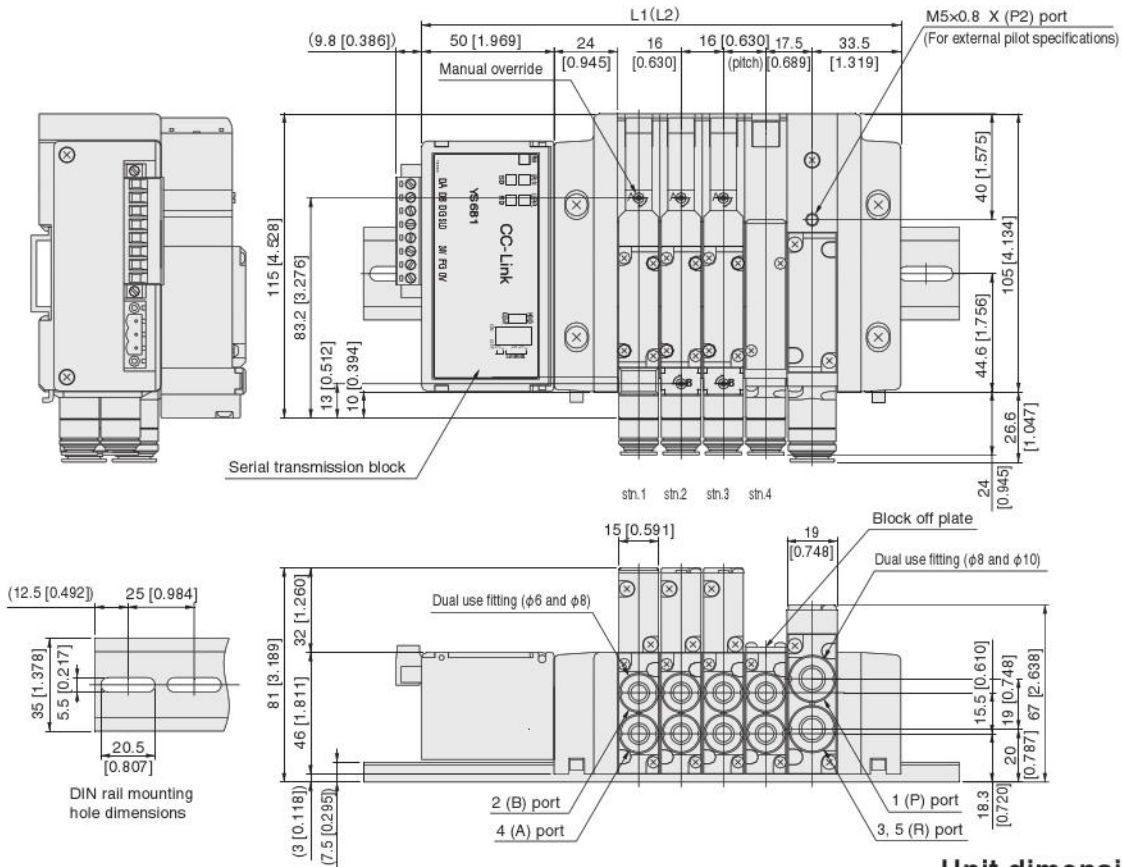

### Unit dimensions

Number of units	L1	Length of DIN rail	L2 <small>Note</small>	Length of DIN rail <small>Note</small>
2	149 [5.866]	200 [7.874]	168 [6.614]	225 [8.858]
3	165 [6.496]	225 [8.858]	184 [7.244]	225 [8.858]
4	181 [7.126]	225 [8.858]	200 [7.874]	250 [9.843]
5	197 [7.756]	250 [9.843]	216 [8.504]	275 [10.827]
6	213 [8.386]	275 [10.827]	232 [9.134]	275 [10.827]
7	229 [9.016]	275 [10.827]	248 [9.764]	300 [11.811]
8	245 [9.646]	300 [11.811]	264 [10.394]	325 [12.795]
9	261 [10.276]	325 [12.795]	280 [11.024]	325 [12.795]
10	277 [10.906]	325 [12.795]	296 [11.654]	350 [13.780]
11	293 [11.536]	350 [13.780]	312 [12.283]	375 [14.764]
12	309 [12.165]	350 [13.780]	328 [12.913]	375 [14.764]
13	325 [12.795]	375 [14.764]	344 [13.543]	400 [15.748]
14	341 [13.425]	400 [15.748]	360 [14.173]	400 [15.748]
15	357 [14.055]	400 [15.748]	376 [14.803]	425 [16.732]
16	373 [14.685]	425 [16.732]	392 [15.433]	450 [17.717]
17	389 [15.315]	450 [17.717]	408 [16.063]	475 [18.701]
18	405 [15.945]	450 [17.717]	424 [16.693]	475 [18.701]
19	421 [16.575]	475 [18.701]	440 [17.323]	500 [19.685]
20	437 [17.205]	500 [19.685]	456 [17.953]	500 [19.685]

Note: When two piping blocks are used.  
\* For right-side mounting wiring (-R), add 3 mm [0.118 in] to the L1 (L2) dimension.

**Dimensions of F15 series serial transmission compatible manifold** mm [in]

**F15M** [Number of valves] **SHL** [Pilot specifications] (Base piping type)

With manifold outlet port female thread block  
(Models that support integrated serial transmission block)

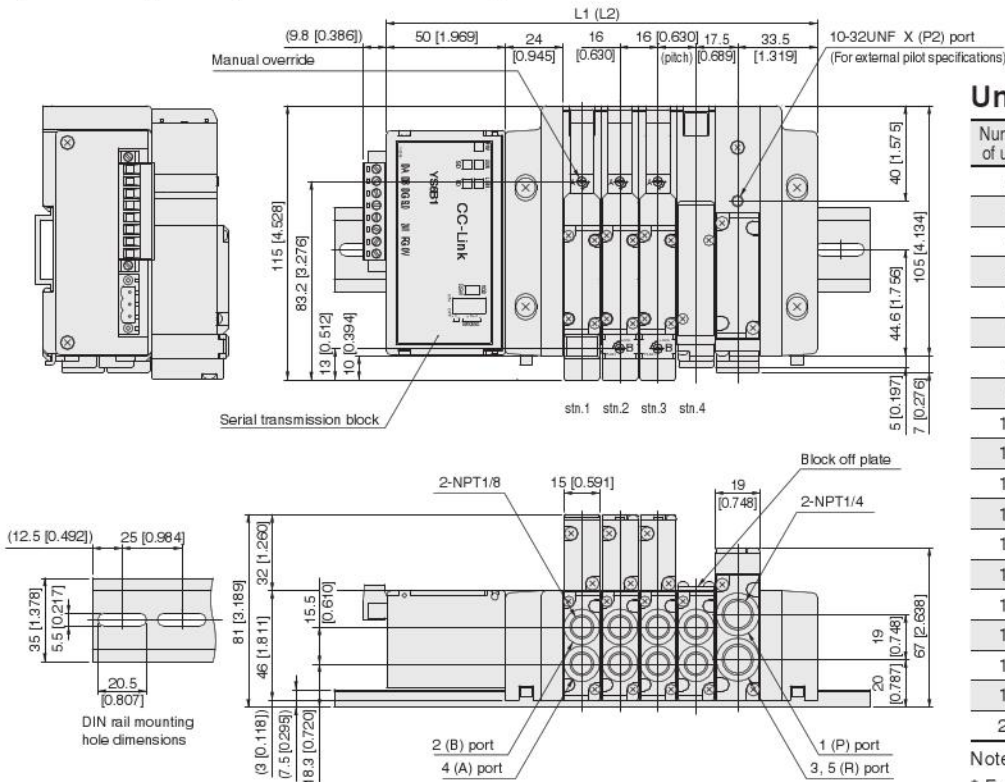

**Unit dimensions**

Number of units	L1	Length of DIN rail	L2 <small>Note</small>	Length of DIN rail <small>Note</small>
2	149 [5.866]	200 [7.874]	168 [6.614]	225 [8.858]
3	165 [6.496]	225 [8.858]	184 [7.244]	225 [8.858]
4	181 [7.126]	225 [8.858]	200 [7.874]	250 [9.843]
5	197 [7.756]	250 [9.843]	216 [8.504]	275 [10.827]
6	213 [8.386]	275 [10.827]	232 [9.134]	275 [10.827]
7	229 [9.016]	275 [10.827]	248 [9.764]	300 [11.811]
8	245 [9.646]	300 [11.811]	264 [10.394]	325 [12.795]
9	261 [10.276]	325 [12.795]	280 [11.024]	325 [12.795]
10	277 [10.906]	325 [12.795]	296 [11.654]	350 [13.780]
11	293 [11.535]	350 [13.780]	312 [12.283]	375 [14.764]
12	309 [12.165]	350 [13.780]	328 [12.913]	375 [14.764]
13	325 [12.795]	375 [14.764]	344 [13.543]	400 [15.748]
14	341 [13.425]	400 [15.748]	360 [14.173]	400 [15.748]
15	357 [14.055]	400 [15.748]	376 [14.803]	425 [16.732]
16	373 [14.685]	425 [16.732]	392 [15.433]	450 [17.717]
17	389 [15.315]	450 [17.717]	408 [16.063]	475 [18.701]
18	405 [15.945]	450 [17.717]	424 [16.693]	475 [18.701]
19	421 [16.575]	475 [18.701]	440 [17.323]	500 [19.685]
20	437 [17.205]	500 [19.685]	456 [17.953]	500 [19.685]

Note: When two piping blocks are used.  
\* For right-side mounting wiring (-R), add 3 mm [0.118 in] to the L1 (L2) dimension.

**F15M** [Number of valves] **SH** [Pilot specifications] (Direct piping type)

With valve outlet port female thread block  
(Models that support integrated serial transmission block)

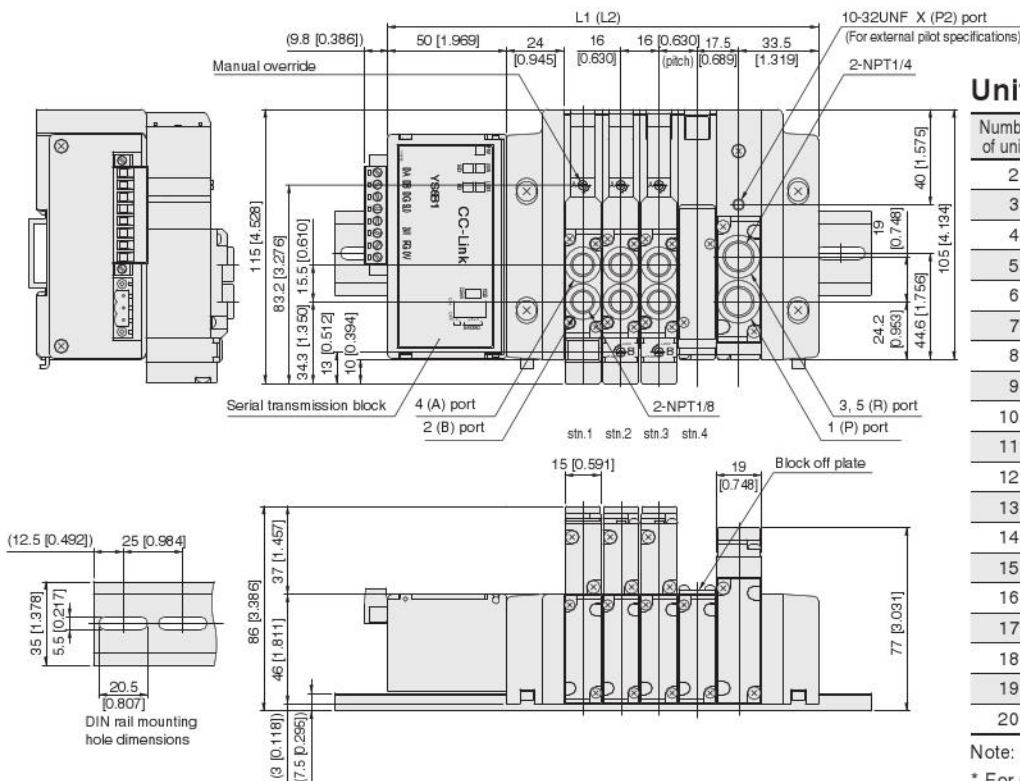

**Unit dimensions**

Number of units	L1	Length of DIN rail	L2 <small>Note</small>	Length of DIN rail <small>Note</small>
2	149 [5.866]	200 [7.874]	168 [6.614]	225 [8.858]
3	165 [6.496]	225 [8.858]	184 [7.244]	225 [8.858]
4	181 [7.126]	225 [8.858]	200 [7.874]	250 [9.843]
5	197 [7.756]	250 [9.843]	216 [8.504]	275 [10.827]
6	213 [8.386]	275 [10.827]	232 [9.134]	275 [10.827]
7	229 [9.016]	275 [10.827]	248 [9.764]	300 [11.811]
8	245 [9.646]	300 [11.811]	264 [10.394]	325 [12.795]
9	261 [10.276]	325 [12.795]	280 [11.024]	325 [12.795]
10	277 [10.906]	325 [12.795]	296 [11.654]	350 [13.780]
11	293 [11.535]	350 [13.780]	312 [12.283]	375 [14.764]
12	309 [12.165]	350 [13.780]	328 [12.913]	375 [14.764]
13	325 [12.795]	375 [14.764]	344 [13.543]	400 [15.748]
14	341 [13.425]	400 [15.748]	360 [14.173]	400 [15.748]
15	357 [14.055]	400 [15.748]	376 [14.803]	425 [16.732]
16	373 [14.685]	425 [16.732]	392 [15.433]	450 [17.717]
17	389 [15.315]	450 [17.717]	408 [16.063]	475 [18.701]
18	405 [15.945]	450 [17.717]	424 [16.693]	475 [18.701]
19	421 [16.575]	475 [18.701]	440 [17.323]	500 [19.685]
20	437 [17.205]	500 [19.685]	456 [17.953]	500 [19.685]

Note: When two piping blocks are used.  
\* For right-side mounting wiring (-R), add 3 mm [0.118 in] to the L1 (L2) dimension.

**F15M** [Number of valves] **S** **M** **J** [Pilot specifications] (Base piping type)

With manifold outlet port dual use fitting block  
(Models that support stand-alone serial transmission block)

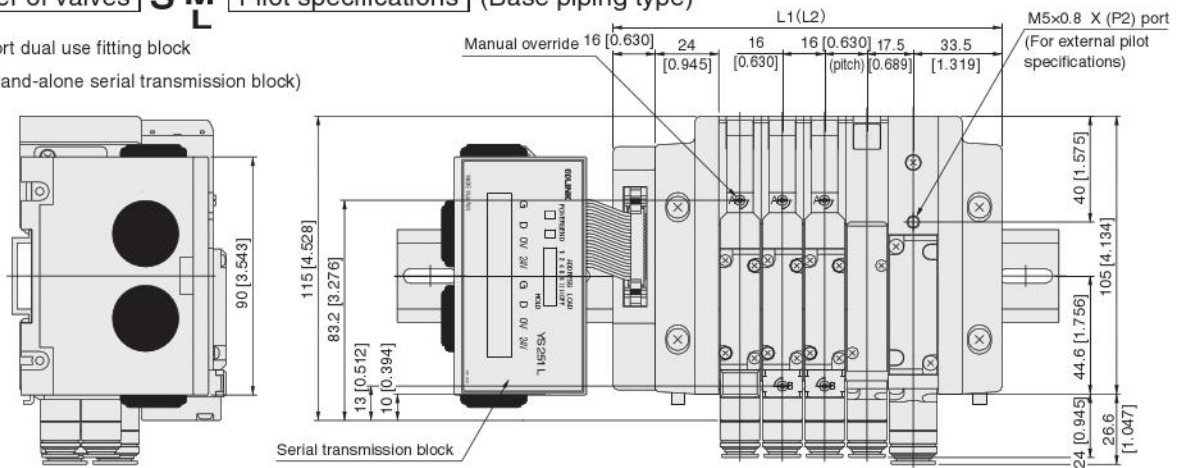

**Unit dimensions**

Number of units	L1	Length of DIN rail	L2 <small>Note</small>	Length of DIN rail <small>Note</small>
2	115 [4.528]	225 [8.858]	134 [5.276]	225 [8.858]
3	131 [5.157]	225 [8.858]	150 [5.906]	250 [9.843]
4	147 [5.787]	250 [9.843]	166 [6.535]	275 [10.827]
5	163 [6.417]	275 [10.827]	182 [7.165]	275 [10.827]
6	179 [7.047]	275 [10.827]	198 [7.795]	300 [11.811]
7	195 [7.677]	300 [11.811]	214 [8.425]	325 [12.795]
8	211 [8.307]	300 [11.811]	230 [9.055]	325 [12.795]
9	227 [8.937]	325 [12.795]	246 [9.685]	350 [13.780]
10	243 [9.567]	350 [13.780]	262 [10.315]	375 [14.764]
11	259 [10.197]	350 [13.780]	278 [10.945]	375 [14.764]
12	275 [10.827]	375 [14.764]	294 [11.575]	400 [15.748]
13	291 [11.457]	400 [15.748]	310 [12.205]	400 [15.748]
14	307 [12.087]	400 [15.748]	326 [12.835]	425 [16.732]
15	323 [12.717]	425 [16.732]	342 [13.465]	450 [17.717]
16	339 [13.346]	450 [17.717]	358 [14.094]	450 [17.717]

Note: When two piping blocks are used.

\* For right-side mounting wiring (-R), add 3 mm [0.118 in] to the L1 (L2) dimension.

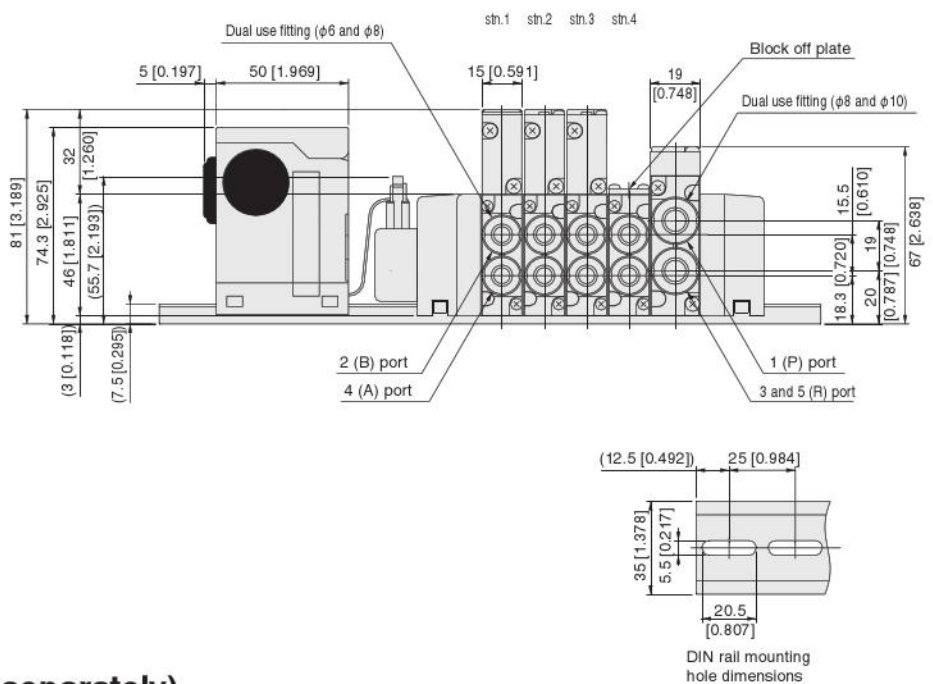

**Additional Parts (available separately)**

● Muffler: **KM-J10** [for both plug-in and non-plug-in]

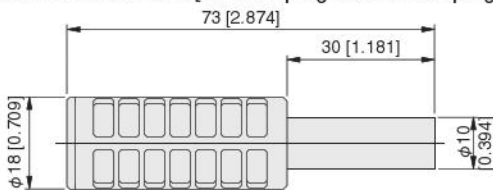

● Muffler: **KM-J6** [for individual exhaust spacer only]

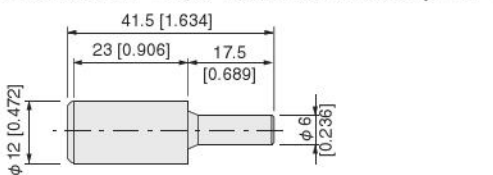

● Muffler: **KM-J8** [for individual exhaust spacer only]

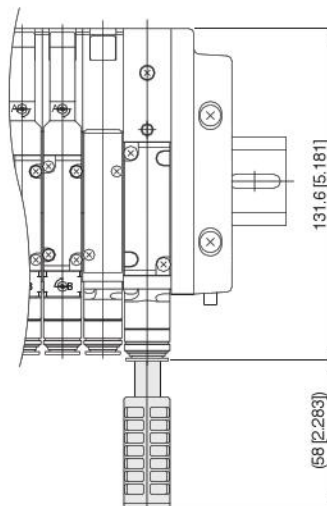
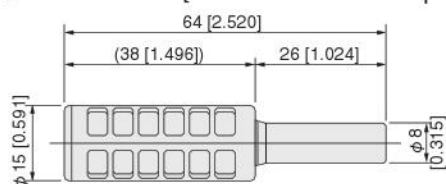

**F15M** [Number of valves] **SHL** [Pilot specifications] (Base piping type)

With manifold outlet port female thread block  
(Models that support stand-alone serial transmission block)

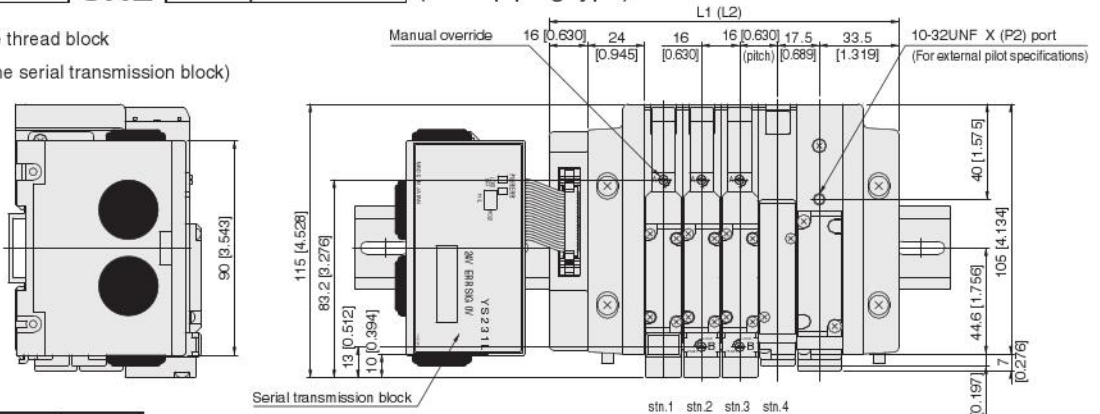

**Unit dimensions**

Number of units	L1	Length of DIN rail	L2 <small>Note</small>	Length of DIN rail <small>Note</small>
2	115 [4.528]	225 [8.858]	134 [5.276]	225 [8.858]
3	131 [5.157]	225 [8.858]	150 [5.906]	250 [9.843]
4	147 [5.787]	250 [9.843]	166 [6.535]	275 [10.827]
5	163 [6.417]	275 [10.827]	182 [7.165]	275 [10.827]
6	179 [7.047]	275 [10.827]	198 [7.795]	300 [11.811]
7	195 [7.677]	300 [11.811]	214 [8.425]	325 [12.795]
8	211 [8.307]	300 [11.811]	230 [9.055]	325 [12.795]
9	227 [8.937]	325 [12.795]	246 [9.685]	350 [13.780]
10	243 [9.567]	350 [13.780]	262 [10.315]	375 [14.764]
11	259 [10.197]	350 [13.780]	278 [10.945]	375 [14.764]
12	275 [10.827]	375 [14.764]	294 [11.575]	400 [15.748]
13	291 [11.457]	400 [15.748]	310 [12.205]	400 [15.748]
14	307 [12.087]	400 [15.748]	326 [12.835]	425 [16.732]
15	323 [12.717]	425 [16.732]	342 [13.465]	450 [17.717]
16	339 [13.346]	450 [17.717]	358 [14.094]	450 [17.717]

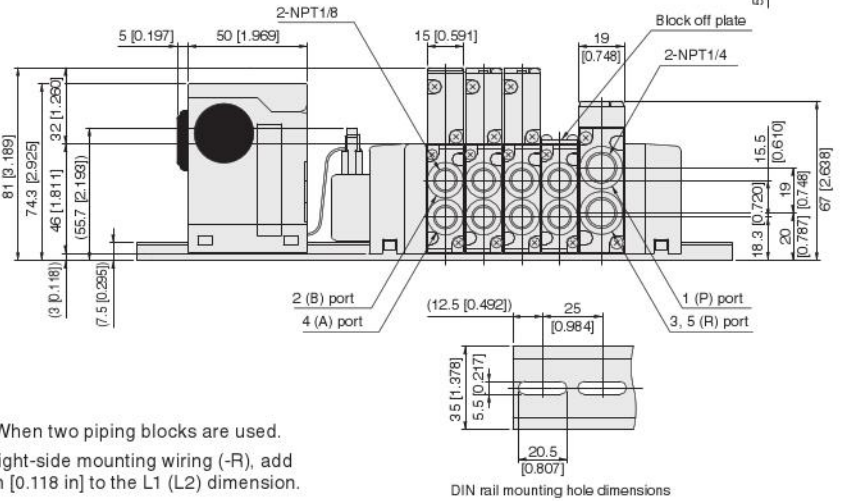

Note: When two piping blocks are used.  
\* For right-side mounting wiring (-R), add 3 mm [0.118 in] to the L1 (L2) dimension.

**F15M** [Number of valves] **SH** [Pilot specifications] (Direct piping type)

With valve outlet port female thread block  
(Models that support stand-alone serial transmission block)

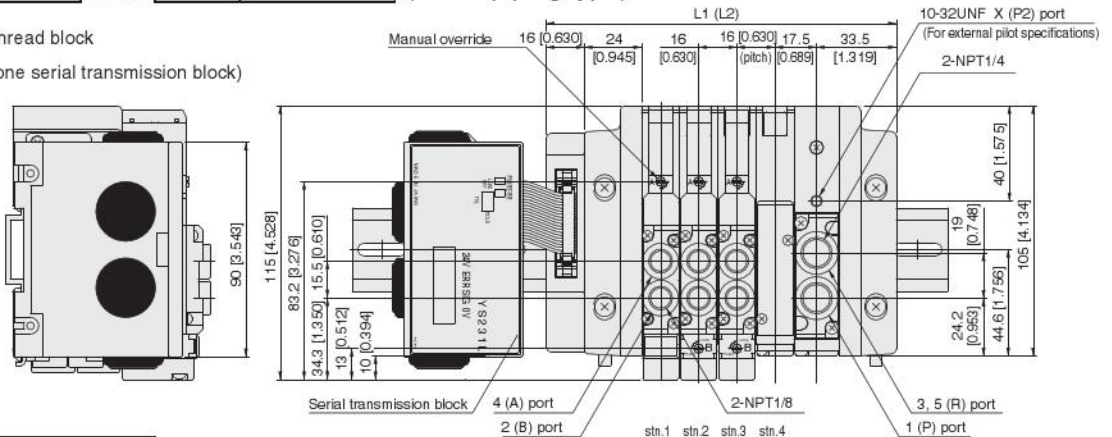

**Unit dimensions**

Number of units	L1	Length of DIN rail	L2 <small>Note</small>	Length of DIN rail <small>Note</small>
2	115 [4.528]	225 [8.858]	134 [5.276]	225 [8.858]
3	131 [5.157]	225 [8.858]	150 [5.906]	250 [9.843]
4	147 [5.787]	250 [9.843]	166 [6.535]	275 [10.827]
5	163 [6.417]	275 [10.827]	182 [7.165]	275 [10.827]
6	179 [7.047]	275 [10.827]	198 [7.795]	300 [11.811]
7	195 [7.677]	300 [11.811]	214 [8.425]	325 [12.795]
8	211 [8.307]	300 [11.811]	230 [9.055]	325 [12.795]
9	227 [8.937]	325 [12.795]	246 [9.685]	350 [13.780]
10	243 [9.567]	350 [13.780]	262 [10.315]	375 [14.764]
11	259 [10.197]	350 [13.780]	278 [10.945]	375 [14.764]
12	275 [10.827]	375 [14.764]	294 [11.575]	400 [15.748]
13	291 [11.457]	400 [15.748]	310 [12.205]	400 [15.748]
14	307 [12.087]	400 [15.748]	326 [12.835]	425 [16.732]
15	323 [12.717]	425 [16.732]	342 [13.465]	450 [17.717]
16	339 [13.346]	450 [17.717]	358 [14.094]	450 [17.717]

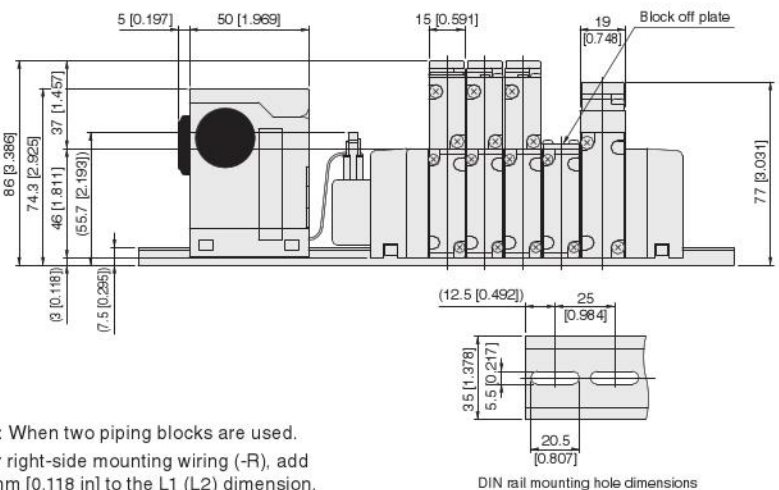

Note: When two piping blocks are used.  
\* For right-side mounting wiring (-R), add 3 mm [0.118 in] to the L1 (L2) dimension.

# Dimensions of F15 series serial transmission compatible manifold mm [in]

## F15M [Number of valves] SHL [Pilot specifications] (Base piping type)

With manifold outlet port female thread block

(EtherCAT)

(EtherNet/IP) ※ The dimensions is EtherCAT.

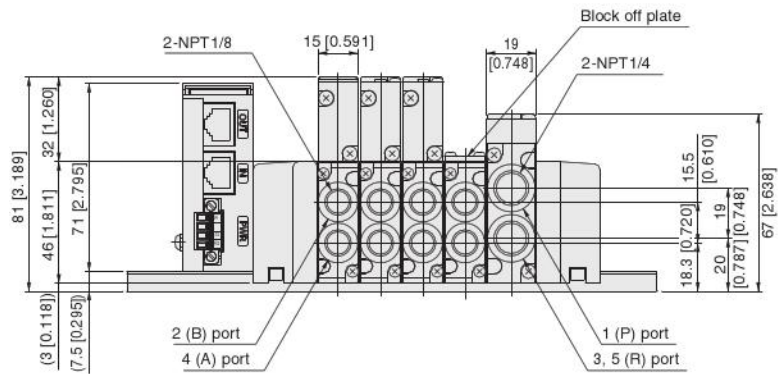
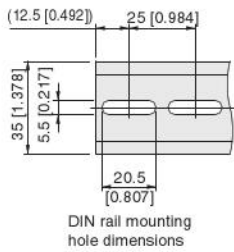
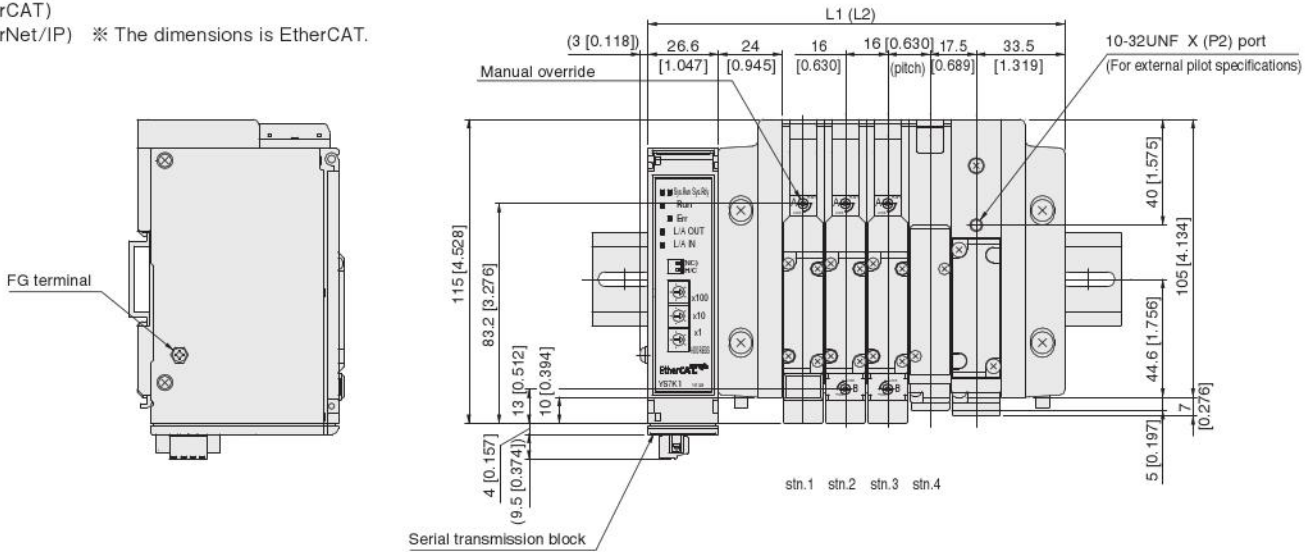

### Unit dimensions

Number of units	L1	Length of DIN rail	L2 <small>Note</small>	Length of DIN rail <small>Note</small>
2	125.6 [4.945]	175 [6.890]	144.6 [5.693]	200 [7.874]
3	141.6 [5.575]	200 [7.874]	160.6 [6.323]	200 [7.874]
4	157.6 [6.205]	200 [7.874]	176.6 [6.953]	225 [8.858]
5	173.6 [6.835]	225 [8.858]	192.6 [7.583]	250 [9.843]
6	189.6 [7.465]	250 [9.843]	208.6 [8.213]	250 [9.843]
7	205.6 [8.094]	250 [9.843]	224.6 [8.843]	275 [10.827]
8	221.6 [8.724]	275 [10.827]	240.6 [9.472]	300 [11.811]
9	237.6 [9.354]	300 [11.811]	256.6 [10.102]	300 [11.811]
10	253.6 [9.984]	300 [11.811]	272.6 [10.732]	325 [12.795]
11	269.6 [10.614]	325 [12.795]	288.6 [11.362]	350 [13.780]
12	285.6 [11.244]	325 [12.795]	304.6 [11.992]	350 [13.780]
13	301.6 [11.874]	350 [13.780]	320.6 [12.622]	375 [14.764]
14	317.6 [12.504]	375 [14.764]	336.6 [13.252]	375 [14.764]
15	333.6 [13.134]	375 [14.764]	352.6 [13.882]	400 [15.748]
16	349.6 [13.764]	400 [15.748]	368.6 [14.512]	425 [16.732]
17	365.6 [14.394]	425 [16.732]	384.6 [15.142]	450 [17.717]
18	381.6 [15.024]	425 [16.732]	400.6 [15.772]	450 [17.717]
19	397.6 [15.654]	450 [17.717]	416.6 [16.402]	475 [18.701]
20	413.6 [16.283]	475 [18.701]	432.6 [17.031]	475 [18.701]

Note: When two piping blocks are used.

\* For right-side mounting wiring (-R), add 3 mm [0.118 in] to the L1 (L2) dimension.

# Dimensions of F15 series serial transmission compatible manifold mm [in]

## F15M [Number of valves] SH [Pilot specifications] (Direct piping type)

With valve outlet port female thread block

(EtherCAT)

(EtherNet/IP) ※ The dimensions is EtherCAT.

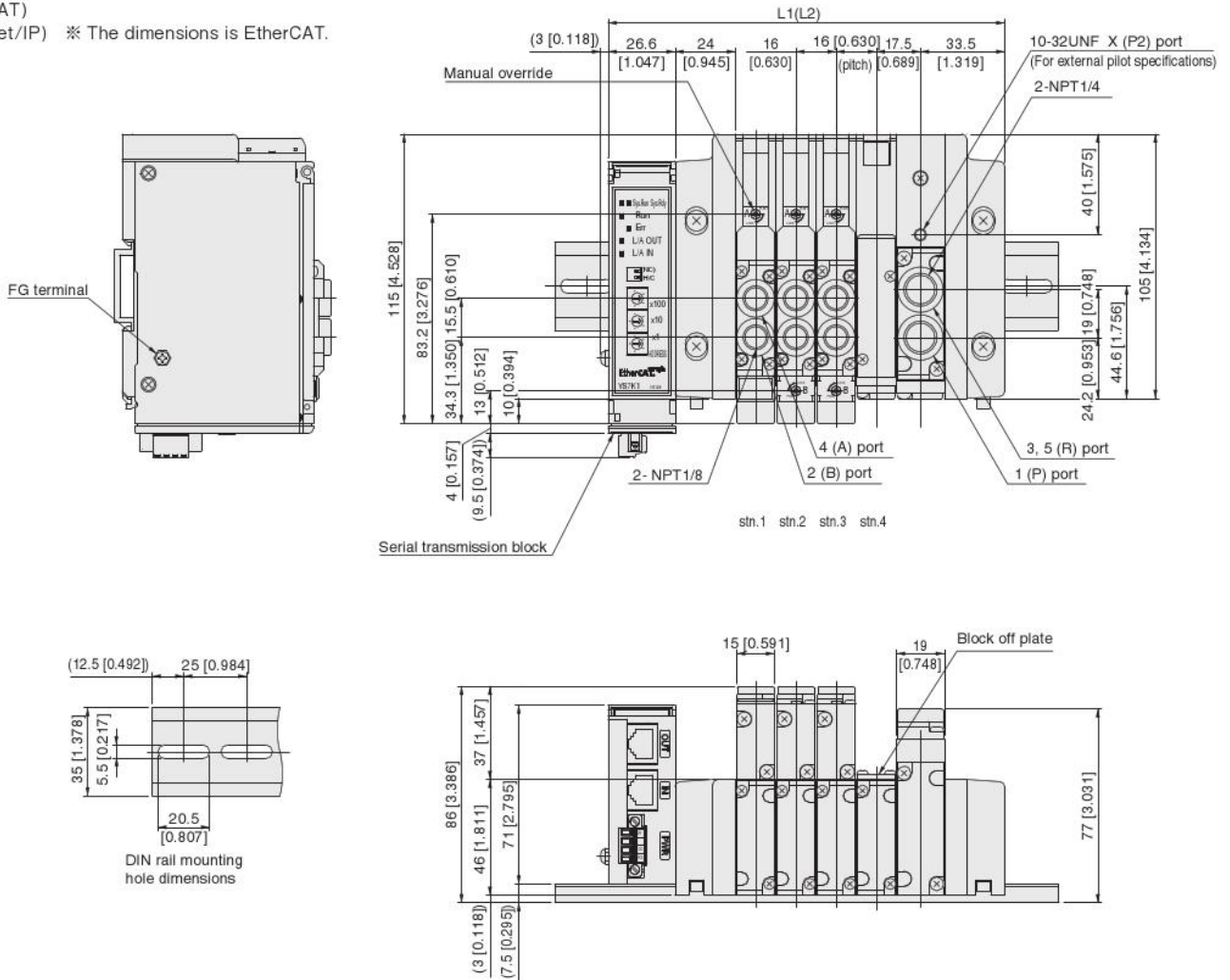

### Unit dimensions

Number of units	L1	Length of DIN rail	L2 <small>Note</small>	Length of DIN rail <small>Note</small>
2	125.6 [4.945]	175 [6.890]	144.6 [5.693]	200 [7.874]
3	141.6 [5.575]	200 [7.874]	160.6 [6.323]	200 [7.874]
4	157.6 [6.205]	200 [7.874]	176.6 [6.953]	225 [8.858]
5	173.6 [6.835]	225 [8.858]	192.6 [7.583]	250 [9.843]
6	189.6 [7.465]	250 [9.843]	208.6 [8.213]	250 [9.843]
7	205.6 [8.094]	250 [9.843]	224.6 [8.843]	275 [10.827]
8	221.6 [8.724]	275 [10.827]	240.6 [9.472]	300 [11.811]
9	237.6 [9.354]	300 [11.811]	256.6 [10.102]	300 [11.811]
10	253.6 [9.984]	300 [11.811]	272.6 [10.732]	325 [12.795]
11	269.6 [10.614]	325 [12.795]	288.6 [11.362]	350 [13.780]
12	285.6 [11.244]	325 [12.795]	304.6 [11.992]	350 [13.780]
13	301.6 [11.874]	350 [13.780]	320.6 [12.622]	375 [14.764]
14	317.6 [12.504]	375 [14.764]	336.6 [13.252]	375 [14.764]
15	333.6 [13.134]	375 [14.764]	352.6 [13.882]	400 [15.748]
16	349.6 [13.764]	400 [15.748]	368.6 [14.512]	425 [16.732]
17	365.6 [14.394]	425 [16.732]	384.6 [15.142]	450 [17.717]
18	381.6 [15.024]	425 [16.732]	400.6 [15.772]	450 [17.717]
19	397.6 [15.654]	450 [17.717]	416.6 [16.402]	475 [18.701]
20	413.6 [16.283]	475 [18.701]	432.6 [17.031]	475 [18.701]

Note: When two piping blocks are used.

\* For right-side mounting wiring (-R), add 3 mm [0.118 in] to the L1 (L2) dimension.



# SOLENOID VALVES

## F18 SERIES

### Contents

Specifications	172
Dimensions of Single Valve Unit	177
Dimensions of Monoblock Manifold	180
Dimensions of Split Manifold Non-plug-in Type	183
Dimensions of Split Manifold Plug-in Type	185
Dimensions of Serial Transmission Compatible Manifold	194

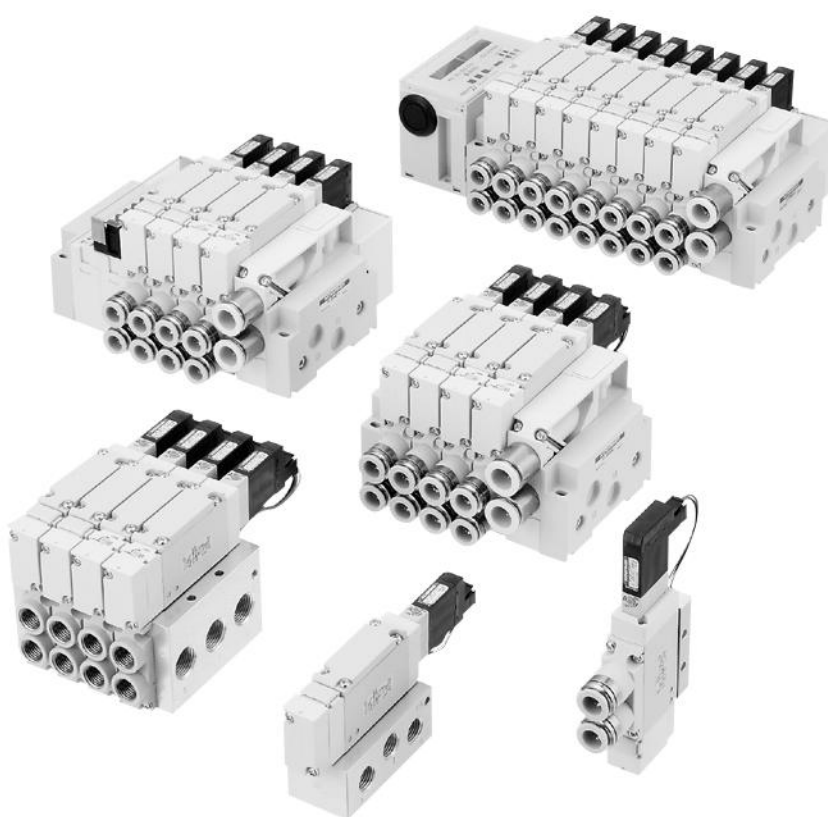

# F18 SERIES Specifications

## Specifications

### Basic Models and Valve Functions

Item	Basic model	F18T0	F18T1 F18T2	F18T3 F18T4 F18T5
	Number of positions	2 positions		
Number of ports	5			
Valve function	Single solenoid only		Both single and double solenoid use	Closed center, Exhaust center, Pressure center

Remark: For the optional specifications and order codes, see p.72-88.

### Specifications

Item	Basic model	F18T0 F18T1 F18T2	F18T3 F18T4 F18T5	F18T0G F18T1G F18T2G	F18T3G F18T4G F18T5G	F18T0V F18T1V F18T2V	F18T3V	
	Media	Air						
Operation type	Internal pilot type		External pilot type (for positive pressure)		External pilot type (for vacuum)			
Flow rate characteristics	Sonic conductance $C \text{ dm}^3/(\text{s} \cdot \text{bar})$ <sup>Note1</sup>	3.6						
	Effective area <sup>Note2</sup> $\text{mm}^2$ (Cv)	18 [1]						
Port size <sup>Note3</sup>	Dual use fitting for $\phi 8$ and $\phi 10$ , Rc1/4, NPT1/4		M5 $\times$ 0.8, 10-32UNF, dual use fitting for $\phi 8$ and $\phi 10$ , Rc1/4, NPT1/4					
Lubrication	Not required							
Operating pressure range	Main valve	0.15~0.7 MPa [22~102 psi.]		0~0.7 MPa [0~102 psi.] <sup>Note4</sup>		-100 kPa~0.15 MPa [-29.53 in.Hg~22 psi.]		
	External pilot	—		0.2~0.7 MPa [29~102 psi.] <sup>Note4</sup>		0.2~0.7 MPa [29~102 psi.]		
Proof pressure	MPa [psi.]		1.05 [152]					
Response time <sup>Note5</sup> ms	12VDC, 24VDC	25/35 or below	15/70 or below	25/35 or below	15/70 or below	25/35 or below	15/70 or below	
	100VAC	25/35 or below	15/70 or below	25/35 or below	15/70 or below	25/35 or below	15/70 or below	
ON/OFF								
Maximum operating frequency	Hz		5					
Minimum time to energize for self holding <sup>Note6</sup> ms	50		—		50		—	
Operating temperature range (atmosphere and media) °C [°F]	5~50 [41~122]							
Shock resistance	$\text{m/s}^2$ [G]		1373 [140] (Axial direction 294.2 [30])	294.2 [30]	1373 [140] (Axial direction 294.2 [30])	294.2 [30]	1373 [140] (Axial direction 294.2 [30])	294.2 [30]
Mounting direction	Any							

- Notes: 1. The sonic conductance value is a calculated value, and not a measured value.  
 2. For details, see the effective area on p.174.  
 3. For details, see the port size on p.174.  
 4. When the main valve pressure is 0.2~0.7 MPa [29~102 psi.], set the external pilot pressure to the main valve pressure or higher, and to 0.7 MPa [102 psi.] or less.

- Notes: 5. Values when air pressure is 0.5 MPa [73 psi.]. For switching phase timing in the AC specification, add a maximum of 5 ms to the response time. The values for 2-position valves are those when used as a single solenoid, and the values for 3-position valves are those when switching from the neutral position of closed center.  
 6. When used as a double solenoid valve. Excludes T0.

Remark: Specification values are based on Koganei test standards.

### Solenoid Specifications

Item	Rated voltage	12VDC	24VDC	100VAC	120VAC	
	Voltage range	V	10.8~13.2 (12 $\pm$ 10%)	21.6~26.4 (24 $\pm$ 10%)	90~110 (100 $\pm$ 10%)	108~132 (120 $\pm$ 10%)
Rated frequency	Hz	—	—	50	60	
Current (when rated voltage is applied) mA (r.m.s)	Starting	—	—	10 <sup>Note 1</sup>	10 <sup>Note 1</sup>	
	Holding	76	38	10 <sup>Note 1</sup>	10 <sup>Note 1</sup>	
Power consumption	W	0.9	0.9	1.0 VA	1.4 VA	
Allowable leakage current	mA	4.0	2.0	2.0	2.0	
Type of insulation	Type B					
Insulation resistance <sup>Note 2</sup>	M $\Omega$	Over 100				
Color of LED indicator <sup>Note 3</sup>	14(SA) : Red, 12(SB) : Green		14(SA) : Red, 12(SB) : Green	14(SA) : Red, 12(SB) : Green		
Surge suppression (as standard)	Flywheel diode			Bridge diode		

- Notes: 1. Since the AC types have built-in bridge diodes, the starting current and holding current values are virtually the same.  
 2. Value at 500VDC megger.  
 3. The color of the T0 indicator is red only.

Remark: Specification values are based on Koganei test standards.

## Specifications for DIN Connector (-39□) Type

### Basic Models and Valve Functions

Item \ Basic model	F18T0	F18T2	F18T3 F18T4 F18T5
Number of positions	2 positions		3 positions
Number of ports	5		
Valve function	Single solenoid only	Double solenoid only	Closed center, Exhaust center, Pressure center

Remark: For the optional specifications and order codes, see p.72-88.

### Specifications

Item \ Basic model	F18T0 F18T2	F18T3 F18T4 F18T5	F18T0G F18T2G	F18T3G F18T4G F18T5G	F18T0V F18T2V	F18T3V
Media	Air					
Operation type	Internal pilot type		External pilot type (for positive pressure)		External pilot type (for vacuum)	
Flow rate characteristics	Sonic conductance $C \text{ dm}^3/(\text{s} \cdot \text{bar})$ <sup>Note1</sup>					
	3.6					
Effective area <sup>Note2</sup>	$\text{mm}^2 \text{ (Cv)}$					
	18 [1]					
Port size <sup>Note3</sup>	Dual use fitting for $\phi 8$ and $\phi 10$ , Rc1/4, NPT1/4		M5 $\times$ 0.8, 10-32UNF, dual use fitting for $\phi 8$ and $\phi 10$ , Rc1/4, NPT1/4			
Lubrication	Not required					
Operating pressure range	Main valve		0.15~0.7 MPa [22~102 psi.]		0~0.7 MPa [0~102 psi.] <sup>Note4</sup>	
	External pilot		—		-100 kPa~0.15 MPa [-29.53 in.Hg~22 psi.]	
Proof pressure	MPa [psi.]		1.05 [152]			
	—		—			
Response time <sup>Note5</sup> ON/OFF	ms	25/35 or below	15/70 or below	25/35 or below	15/70 or below	25/35 or below
Maximum operating frequency	Hz	5				
Minimum time to energize for self holding <sup>Note6</sup>	ms	50	—	50	—	50
Operating temperature range (atmosphere and media)	$^{\circ}\text{C} [^{\circ}\text{F}]$	5~50 [41~122]				
Shock resistance	$\text{m/s}^2 \text{ [G]}$	1373 [140]	294.2 [30]	1373 [140]	294.2 [30]	1373 [140]
		(Axial direction 294.2 [30])	(Axial direction 294.2 [30])	(Axial direction 294.2 [30])	(Axial direction 294.2 [30])	(Axial direction 294.2 [30])
Mounting direction	Any					

Notes: 1. The sonic conductance value is a calculated value, and not a measured value.  
 2. For details, see the effective area on p.174.  
 3. For details, see the port size on p.174.  
 4. When the main valve pressure is 0.2~0.7 MPa [29~102 psi.], set the external pilot pressure to the main valve pressure or higher, and to 0.7 MPa [102 psi.] or less.

Notes: 5. Values when air pressure is 0.5 MPa [73 psi.]. For switching phase timing in the AC specification, add a maximum of 5 ms to the response time. The values for 2-position valves are those when used as a single solenoid, and the values for 3-position valves are those when switching from the neutral position of closed center.  
 6. In the case of a double solenoid valve.

Remark: Specification values are based on Koganei test standards.

### Solenoid Specifications for DIN Connector (-39□) Type

Item \ Rated voltage	12VDC	24VDC	120VAC	240VAC
Voltage range	V	10.8~13.2 ( $12 \pm 10\%$ )	21.6~26.4 ( $24 \pm 10\%$ )	90~132
Current	Frequency	Hz	—	50
	Starting	mA (r.m.s)	—	60
	Holding	mA (r.m.s)	43	38
Allowable leakage current	mA	140 (1.7W)	75 (1.8W)	29
Insulation resistance <sup>Note</sup>	MΩ	8	4	4
Surge suppression (as standard)	Surge absorption transistor		Varistor	Varistor

Note: Value at 500VDC megger.

Remark: Specification values are based on Koganei test standards.

## Cylinder Operating Speed

### How to obtain cylinder speed

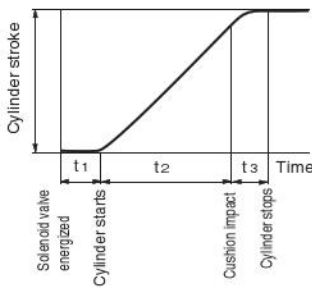

### Measuring conditions

- Air pressure : 0.5 MPa [73 psi.]
- Piping (outer diameter × inner diameter × length) :  $\phi 10 \times \phi 7.5 \times 1000$  mm [39 in.]
- Fitting : Quick fitting TS10-02
- Load ratio =  $\frac{\text{Load}}{\text{Cylinder theoretical thrust}}$  (%)
- Cylinder stroke : 150 mm [5.91 in.]

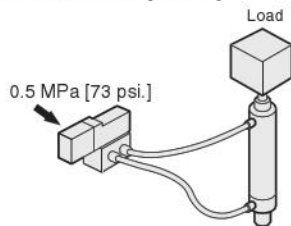

### Maximum operating speed

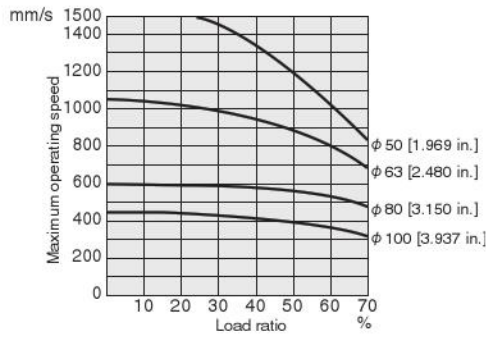

### Delay time

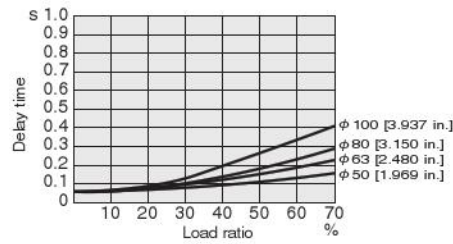

Note: Delay time may vary according to the cylinder stroke.

## Flow Rate

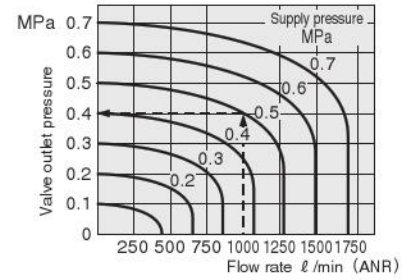

### How to read the graph

When the supply pressure is 0.5 MPa [73 psi.] and flow rate is 1000 l/min [35.3 ft.<sup>3</sup>/min.] (ANR), the valve outlet pressure becomes 0.4 MPa [58 psi.].

- 1 mm/s = 0.0394 in./sec.
- 1 MPa = 145 psi.
- 1 l/min = 0.0353 ft.<sup>3</sup>/min.

## Port Size

Description/Piping specification		PR	X (P2)	4 (A), 2 (B)	1 (P), 3 (R2), 5 (R1), 3, 5 (R)
Single unit	With sub-base	M5 × 0.8, 10-32UNF	M5 × 0.8, 10-32UNF	Rc1/4, NPT1/4	Rc1/4, NPT1/4
	With female thread block	—	—	Rc1/4, NPT1/4	Rc1/4, NPT1/4
	With dual use fitting block	—	—	Dual use fitting for $\phi 8$ and $\phi 10$	Rc1/4, NPT1/4
	With single use fitting block	—	—	$\phi 8$ or $\phi 10$	Rc1/4, NPT1/4
Manifold	Monoblock type with female thread block	M5 × 0.8, 10-32UNF	M5 × 0.8, 10-32UNF	Rc1/4, NPT1/4	Rc3/8, NPT3/8
	Monoblock type with fitting block	M5 × 0.8, 10-32UNF	M5 × 0.8, 10-32UNF	Dual use fitting for $\phi 8$ and $\phi 10$	Rc3/8, NPT3/8
	Monoblock type with single use fitting block	M5 × 0.8, 10-32UNF	M5 × 0.8, 10-32UNF	$\phi 8$ or $\phi 10$	Rc3/8, NPT3/8
	Split type with female thread block, and serial transmission type with female thread block	—	M5 × 0.8, 10-32UNF	Rc1/4, NPT1/4	Rc3/8, NPT3/8
	Split type with fitting block, and serial transmission type with fitting block	—	M5 × 0.8, 10-32UNF	Dual use fitting for $\phi 8$ and $\phi 10$	Single use fitting for $\phi 12$
	Split type with single use fitting block, and serial transmission type with single use fitting block	—	M5 × 0.8, 10-32UNF	$\phi 8$ or $\phi 10$	Single use fitting for $\phi 12$

## Effective Area [Cv]

### ● When used as a single unit

Basic model	Effective area	Basic model	Effective area
F18T0□-A2	17.3 [0.96]	F18T0□-F5	15.0 [0.83]
F18T1□-A2			
F18T2□-A2			
F18T3□-A2			
F18T4□-A2			
F18T5□-A2			
F18T0□-F3	17.0 [0.94]	F18T0□-F6	16.5 [0.91]
F18T1□-F3			
F18T2□-F3			
F18T3□-F3			
F18T4□-F3			
F18T5□-F3			
F18T0□-F4	17.3 [0.96]	F18T0□-F6	16.5 [0.91]
F18T1□-F4			
F18T2□-F4			
F18T3□-F4			
F18T4□-F4			
F18T5□-F4			

### ● When mounted on a manifold

Manifold model		mm <sup>2</sup> [Cv]		
Valve type	Manifold model	F18M□F	F18M□A	F18M□N(P)(S)
F18T0□	Outlet port	17.0 [0.94]	16.0 [0.89]	18.0 [1]
	Dual use fitting for $\phi 8$ and $\phi 10$ , Female thread			
F18T1□	Outlet port $\phi 8$ fitting	15.0 [0.83]	14.7 [0.82]	16.7 [0.93]
F18T2□				
F18T3□				
F18T4□	Outlet port $\phi 10$ fitting	16.5 [0.91]	15.0 [0.83]	17.0 [0.94]
F18T5□				

Caution: When the individual air supply spacer or the individual air exhaust spacer is used, effective area decreases by about 30%.

Remark: Specification values are based on Koganei test standards.

# Mass

## Single Valve Unit Mass

g [oz.]

F18T□□	F18T□□-A1	F18T□□-A2	F18T□□-FJ	F18T□□-FJ5	F18T□□-FJ6
Outlet portion None	Outlet portion With plate	Outlet portion With plate	Outlet portion With dual use fitting block	Outlet portion With φ 8 fitting block	Outlet portion With φ 10 fitting block
Inlet portion None	Inlet portion None	Inlet portion With A type sub-base	Inlet portion None	Inlet portion None	Inlet portion None
118 [4.16]	144 [5.08]	308 [10.86]	159 [5.61]	184 [6.49]	193 [6.81]

g [oz.]

F18T□□-FM	F18T□□-F3	F18T□□-F4	F18T□□-F5	F18T□□-F6
Outlet portion With female thread block	Outlet portion With dual use fitting block	Outlet portion With female thread block	Outlet portion With φ 8 fitting block	Outlet portion With φ 10 fitting block
Inlet portion None	Inlet portion With female thread block	Inlet portion With female thread block	Inlet portion With female thread block	Inlet portion With female thread block
147 [5.19]	184 [6.49]	172 [6.07]	209 [7.37]	218 [7.69]

Basic Type **F18T0** is 15 g [0.53 oz.] less than the mass shown above.

## Monoblock Manifold Mass (single valve unit included)

g [oz.]

Monoblock manifold	Mass calculation of each unit			
	4(A), 2(B) ports outlet specifications			
	Female thread block	Dual use fitting block	φ 8 fitting block	φ 10 fitting block
A type	$(334 \times n) + 165$ [(11.78 × n) + 5.82]	$(344 \times n) + 165$ [(12.13 × n) + 5.82]	$(369 \times n) + 165$ [(13.02 × n) + 5.82]	$(378 \times n) + 165$ [(13.33 × n) + 5.82]
F type	$(222 \times n) + 70$ [(7.83 × n) + 2.47]	$(232 \times n) + 70$ [(8.18 × n) + 2.47]	$(257 \times n) + 70$ [(9.07 × n) + 2.47]	$(266 \times n) + 70$ [(9.38 × n) + 2.47]

Calculation example : **F18M8AM**

stn.1~stn.8 **F18T1-A1-PS DC24V**

$(334 \times 8) + 165 = 2837$  g [100.07 oz.]

When mounting a block-off plate, subtract 110 g [3.88 oz.] per unit from the above calculation result for the female thread specification; subtract 120 g [4.23 oz.] for the dual use fitting specification; subtract 145 g [5.11 oz.] for the φ 8 fitting specification; and subtract 154 g [5.43 oz.] for the φ 10 fitting specification.

When mounting the **F18T0** specification valve, subtract 15 g [0.53 oz.] per unit from the above calculation result.

## Mass of Split Manifold and Serial Transmission Compatible Manifold

Because the valve and manifold have the same output specifications, their mass is the same. The mass can only be changed by choosing a different type of inlet/outlet block.

## Mass of Split Manifold Non-Plug-in Type (single valve unit included)

g [oz.]

Non-plug-in type	Mass calculation of each unit			
	4(A), 2(B) ports outlet specifications			
	Female thread block	Dual use fitting block	φ 8 fitting block	φ 10 fitting block
	$(241 \times n) + 234$ [(8.50 × n) + 8.25]	$(251 \times n) + 234$ [(8.85 × n) + 8.25]	$(276 \times n) + 234$ [(9.74 × n) + 8.25]	$(285 \times n) + 234$ [(10.05 × n) + 8.25]

g [oz.]

Additional mass	
Piping block specification	
Female thread block	Fitting block
164 [5.78]	189 [6.67]

Calculation example : **F18M8N-MR**

stn.1~stn.8 **F18T1-A1-PS DC24V**

$(241 \times 8) + 234 + 164 = 2326$  g [82.05 oz.]

When mounting a block-off plate, subtract 110 g [3.88 oz.] per unit from the above calculation result for the female thread specification; subtract 120 g [4.23 oz.] for the dual use fitting specification; subtract 145 g [5.11 oz.] for the φ 8 fitting specification; and subtract 154 g [5.43 oz.] for the φ 10 fitting specification.

When mounting the **F18T0** specification valve, subtract 15 g [0.53 oz.] per unit from the above calculation result.

# Mass

## Mass of Split Manifold Plug-in Type/ Serial Transmission Compatible Manifold (single valve unit included) g [oz.]

Plug-in type  Serial transmission compatible manifold	Mass calculation of each unit			
	4(A), 2(B) ports outlet specifications			
	Female thread block	Dual use fitting block	φ 8 fitting block	φ 10 fitting block
	$(243 \times n) + 238$ [(8.57 × n) + 8.40]	$(253 \times n) + 238$ [(8.92 × n) + 8.40]	$(278 \times n) + 238$ [(9.81 × n) + 8.40]	$(287 \times n) + 238$ [(10.12 × n) + 8.40]

g [oz.]

Additional mass	
Piping block specification	
Female thread block	Fitting block
174 [6.14]	199 [7.02]

g [oz.]

Additional mass				
Wiring block specification				
<b>-F100, -F101</b>	<b>-F200, -F201, -F260</b>	<b>-D250, -D251</b>	<b>-D370NU</b>	<b>-T200</b>
69 [2.43]	71 [2.50]	72 [2.54]	96 [3.39]	154 [5.43]

g [oz.]

Additional mass	
Serial transmission block	
160 [5.64] (236 [8.32] for CompoNet)	

Calculation example : **F18M8PM-MR-F201 DC24V**

**stn.1~stn.8 F18T1-A1 DC24V**

$(243 \times 8) + 238 + 174 + 71 = 2427$  g [85.61 oz.]

When mounting the block-off plate, subtract 130 g [4.59 oz.] per unit from the above calculation result.

When mounting the **F18□T0** specification valve, subtract 15 g [0.53 oz.] per unit from the above calculation result.

**F18T** Valve specifications **-F3-PS**

With outlet port dual use fitting block  
 With inlet port female thread block  
 S type plug connector

\* For T0 Type dimensions, see page 178.

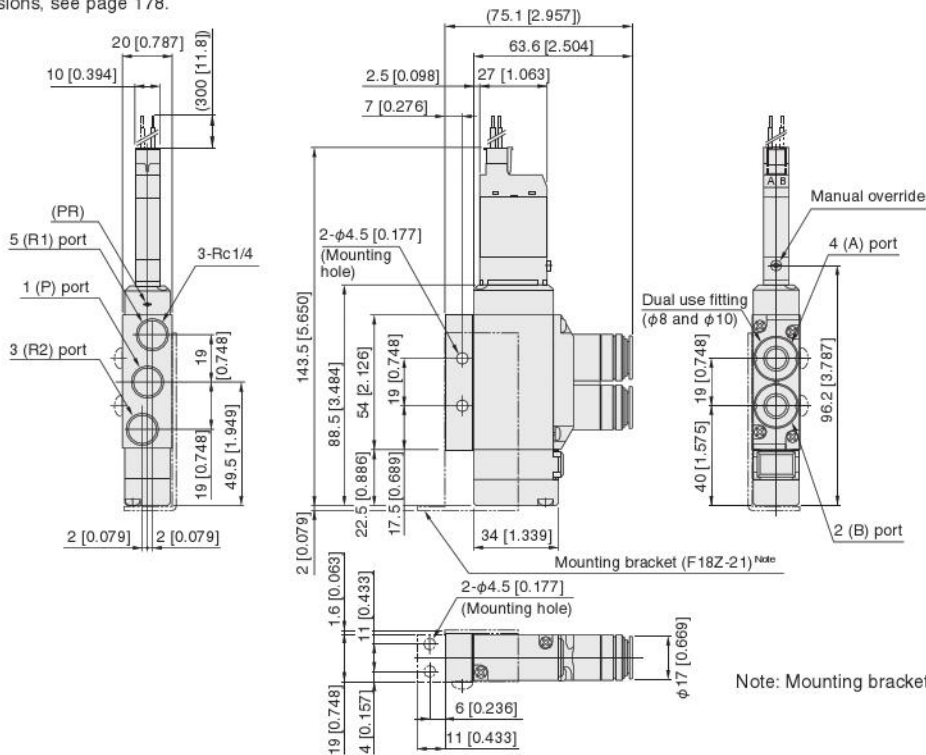

Note: Mounting brackets are additional parts (options).

**F18T** Valve specifications **-F4-PS**

**F18T** Valve specifications **-F4H-PS**

With outlet port female thread block  
 With inlet port female thread block  
 S type plug connector

\* For T0 Type dimensions, see page 178.

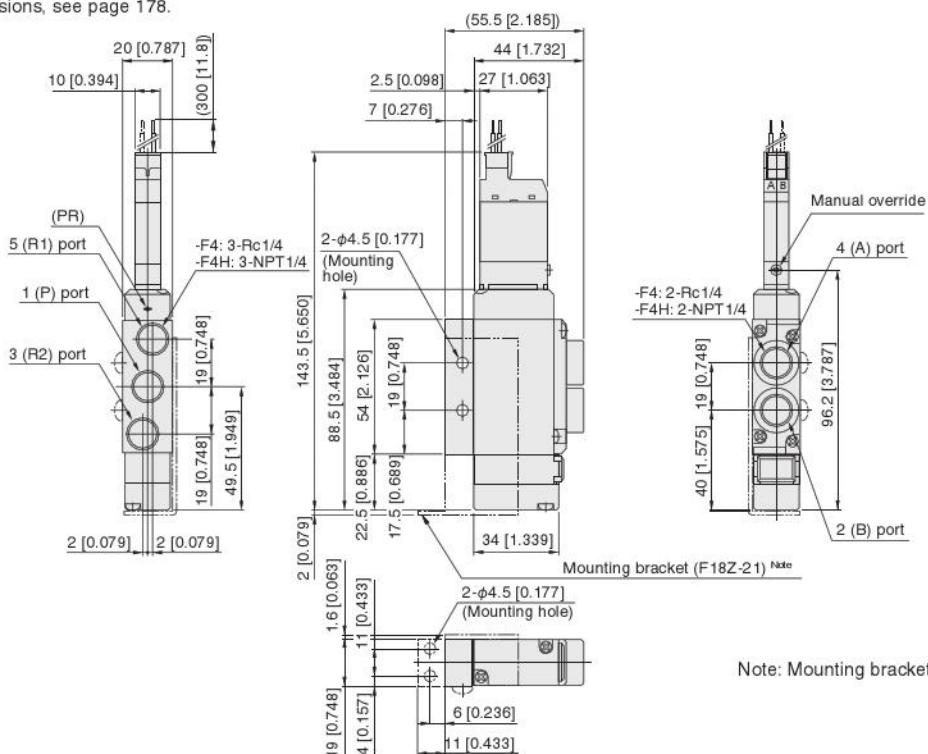

Note: Mounting brackets are additional parts (options).



**F18T** Valve specifications Operation system **-A2-PS**

**F18T** Valve specifications Operation system **-A2H-PS**

With A-type sub-base  
S type plug connector

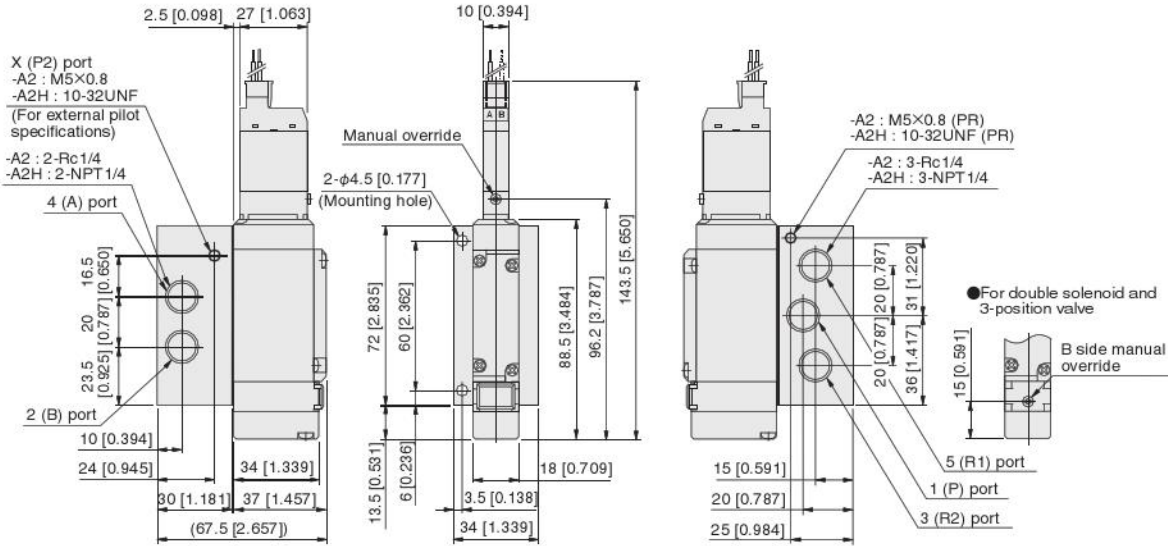

Note: The overall valve length of the T0 type is 12 mm [0.472 in] shorter (end cover side protrusion is 12 mm [0.472 in] less).

**Options**

● L type plug connector: **-PL**

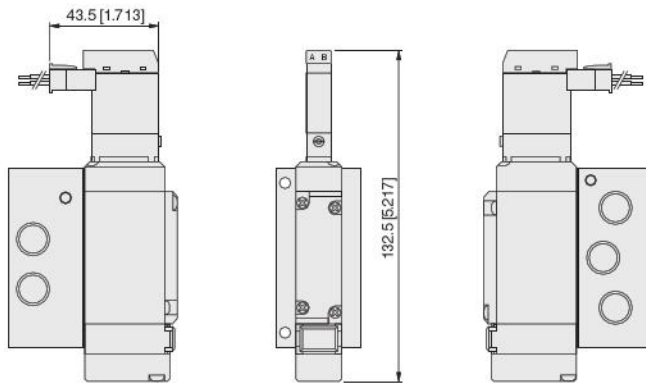

Note: The overall valve length of the T0 type is 12 mm [0.472 in] shorter (end cover side protrusion is 12 mm [0.472 in] less).

● Manual lever: **-R**

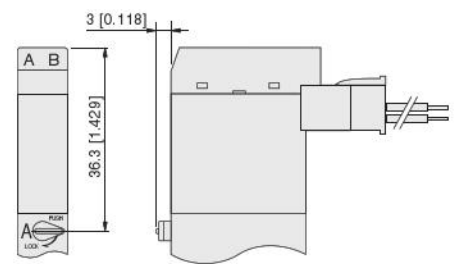

● Solenoid with DIN type connector: **-39**

Pg. 7 Compatible cable diameter φ4 to φ6

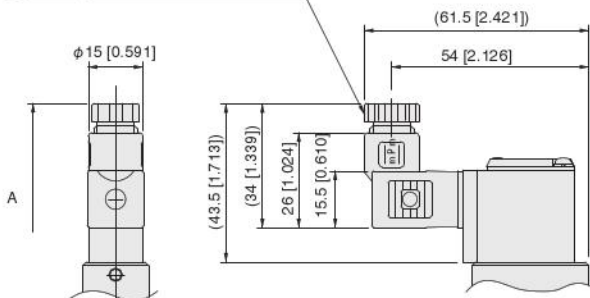

Model	Symbol	A (Full length)
F18T0		127.7 [5.028]
F18T2		180.4 [7.102]
F18T2 to T5		192.4 [7.575]

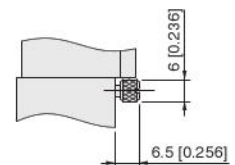

● Protruding locking type manual override: **-83**

Dimensions of F18 series monoblock manifold A type mm [in]

**F18M** Number of valves **A<sub>M</sub>** Pilot specifications (Base piping type)



Monoblock manifold A type  
With manifold outlet port dual use fitting block  
S type plug connector

● Internal pilot specifications

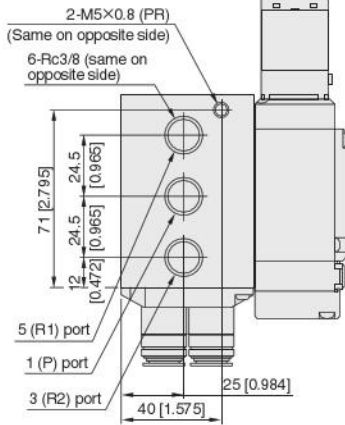

● External pilot specifications

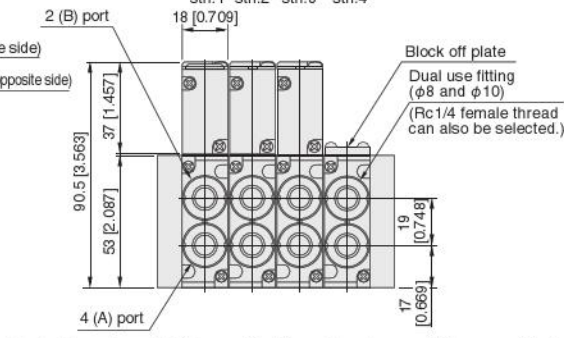
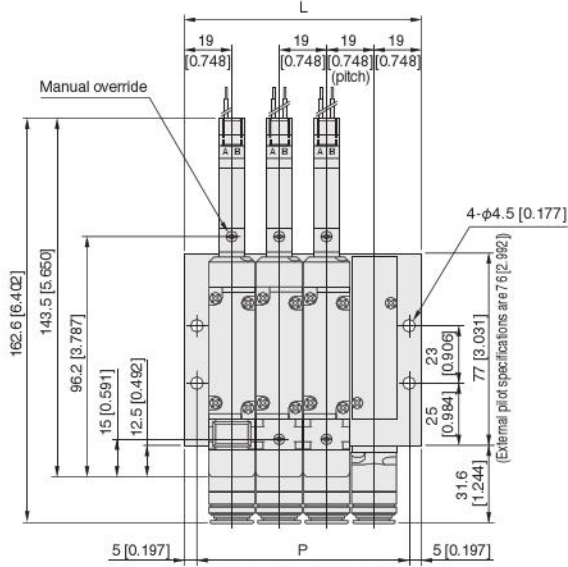
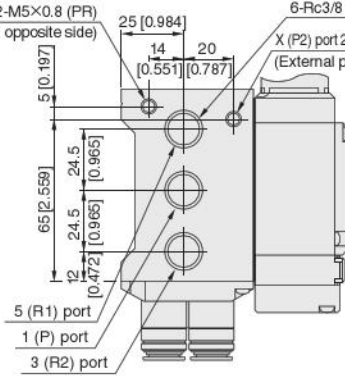

Note: For external pilot specifications, the shape of the monoblock manifold A type body is different from the internal pilot specifications.

Unit dimensions

Number of units	L	P
2	57 [2.244]	47 [1.850]
3	76 [2.992]	66 [2.598]
4	95 [3.740]	85 [3.346]
5	114 [4.488]	104 [4.094]
6	133 [5.236]	123 [4.843]
7	152 [5.984]	142 [5.591]
8	171 [6.732]	161 [6.339]
9	190 [7.480]	180 [7.087]
10	209 [8.228]	199 [7.835]
11	228 [8.976]	218 [8.583]
12	247 [9.724]	237 [9.331]
13	266 [10.472]	256 [10.079]
14	285 [11.220]	275 [10.827]
15	304 [11.969]	294 [11.575]
16	323 [12.717]	313 [12.323]
17	342 [13.465]	332 [13.071]
18	361 [14.213]	351 [13.819]
19	380 [14.961]	370 [14.567]
20	399 [15.709]	389 [15.315]

**F18M** Number of valves **AL** Pilot specifications (Base piping type)

Monoblock manifold A type  
With manifold outlet port single use fitting block  
S type plug connector

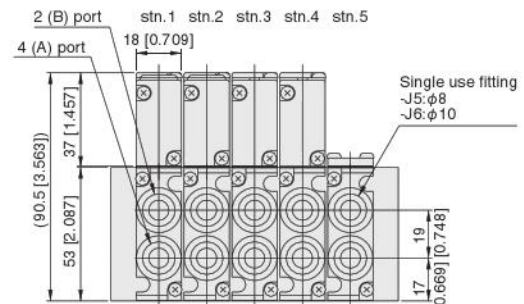
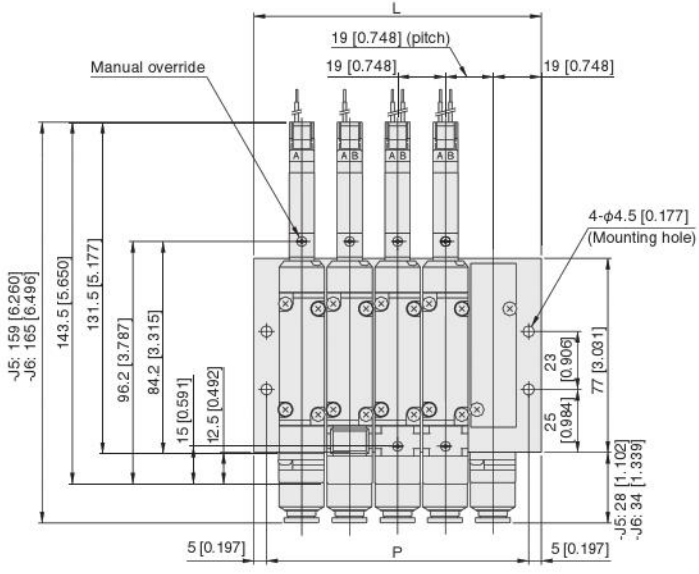
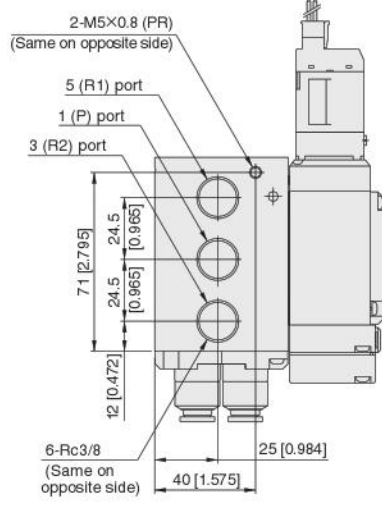

Unit dimensions

Number of units	L	P
2	57 [2.244]	47 [1.850]
3	76 [2.992]	66 [2.598]
4	95 [3.740]	85 [3.346]
5	114 [4.488]	104 [4.094]
6	133 [5.236]	123 [4.843]
7	152 [5.984]	142 [5.591]
8	171 [6.732]	161 [6.339]
9	190 [7.480]	180 [7.087]
10	209 [8.228]	199 [7.835]
11	228 [8.976]	218 [8.583]
12	247 [9.724]	237 [9.331]
13	266 [10.472]	256 [10.079]
14	285 [11.220]	275 [10.827]
15	304 [11.969]	294 [11.575]
16	323 [12.717]	313 [12.323]
17	342 [13.465]	332 [13.071]
18	361 [14.213]	351 [13.819]
19	380 [14.961]	370 [14.567]
20	399 [15.709]	389 [15.315]

# Dimensions of F18 series monoblock manifold A type mm [in]

## F18M Number of valves AHL Pilot specifications (Base piping type)



Monoblock manifold A type  
 With manifold outlet port female thread block  
 S type plug connector

### Internal pilot specifications

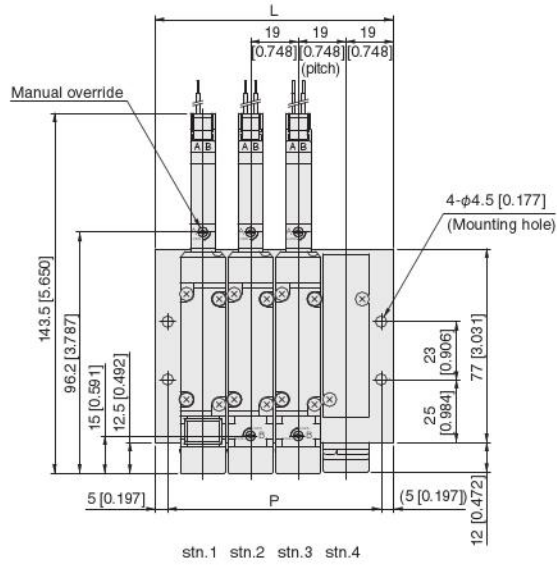
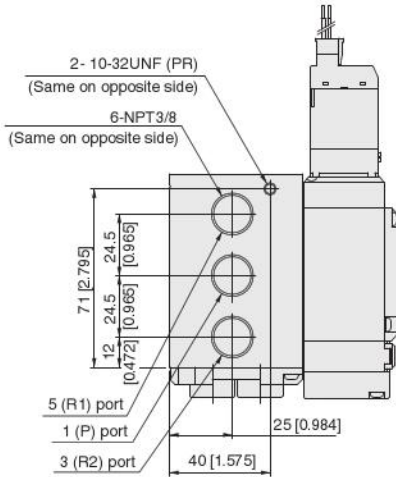

### External pilot specifications Note

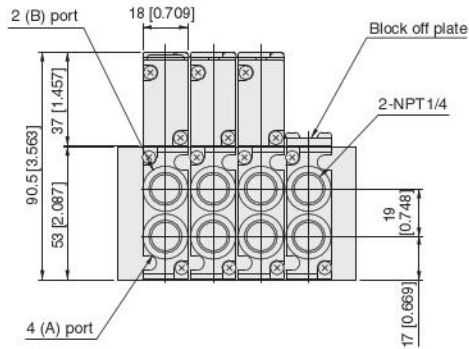
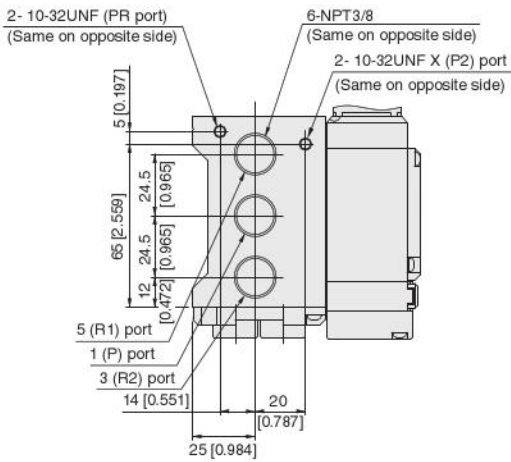

Note: For external pilot specifications, the shape of the monoblock manifold A type body is different from the internal pilot specifications.

### Unit dimensions

Number of units	L	P
2	57 [2.244]	47 [1.850]
3	76 [2.992]	66 [2.598]
4	95 [3.740]	85 [3.346]
5	114 [4.488]	104 [4.094]
6	133 [5.236]	123 [4.843]
7	152 [5.984]	142 [5.591]
8	171 [6.732]	161 [6.339]
9	190 [7.480]	180 [7.087]
10	209 [8.228]	199 [7.835]
11	228 [8.976]	218 [8.583]
12	247 [9.724]	237 [9.331]
13	266 [10.472]	256 [10.079]
14	285 [11.220]	275 [10.827]
15	304 [11.969]	294 [11.575]
16	323 [12.717]	313 [12.323]
17	342 [13.465]	332 [13.071]
18	361 [14.213]	351 [13.819]
19	380 [14.961]	370 [14.567]
20	399 [15.709]	389 [15.315]

# Dimensions of F18 series monoblock manifold F type mm [in]



## F18M [Number of valves] F (Direct piping type)

Monoblock manifold F type  
With valve outlet port dual use fitting block  
S type plug connector

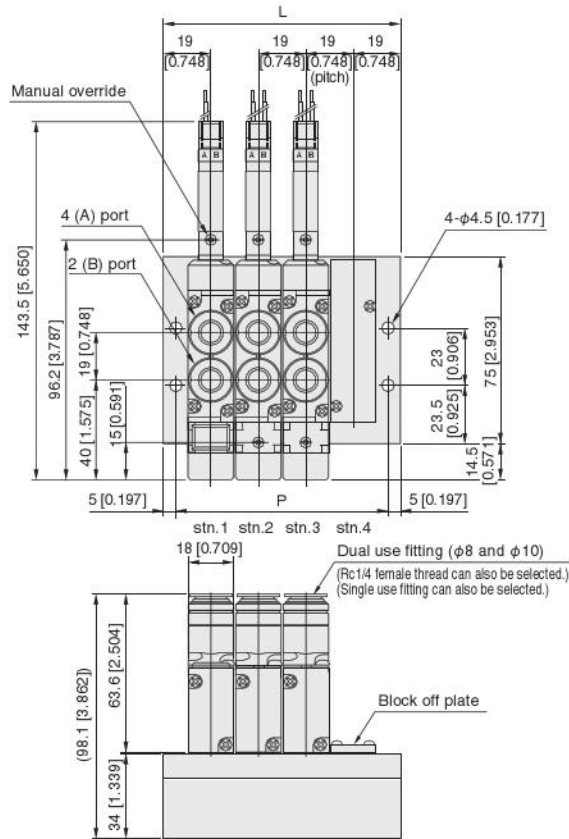
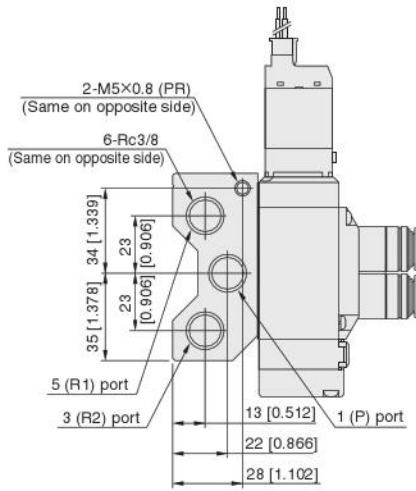

Note: The overall valve length of the T0 type is 12 mm [0.472 in] shorter (end cover side protrusion is 12 mm [0.472 in] less).

## Unit dimensions

Number of units	L	P
2	57 [2.244]	47 [1.850]
3	76 [2.992]	66 [2.598]
4	95 [3.740]	85 [3.346]
5	114 [4.488]	104 [4.094]
6	133 [5.236]	123 [4.843]
7	152 [5.984]	142 [5.591]
8	171 [6.732]	161 [6.339]
9	190 [7.480]	180 [7.087]
10	209 [8.228]	199 [7.835]
11	228 [8.976]	218 [8.583]
12	247 [9.724]	237 [9.331]
13	266 [10.472]	256 [10.079]
14	285 [11.220]	275 [10.827]
15	304 [11.969]	294 [11.575]
16	323 [12.717]	313 [12.323]
17	342 [13.465]	332 [13.071]
18	361 [14.213]	351 [13.819]
19	380 [14.961]	370 [14.567]
20	399 [15.709]	389 [15.315]

## F18M [Number of valves] FH (Direct piping type)

Monoblock manifold F type  
With valve outlet port female thread block  
S type plug connector

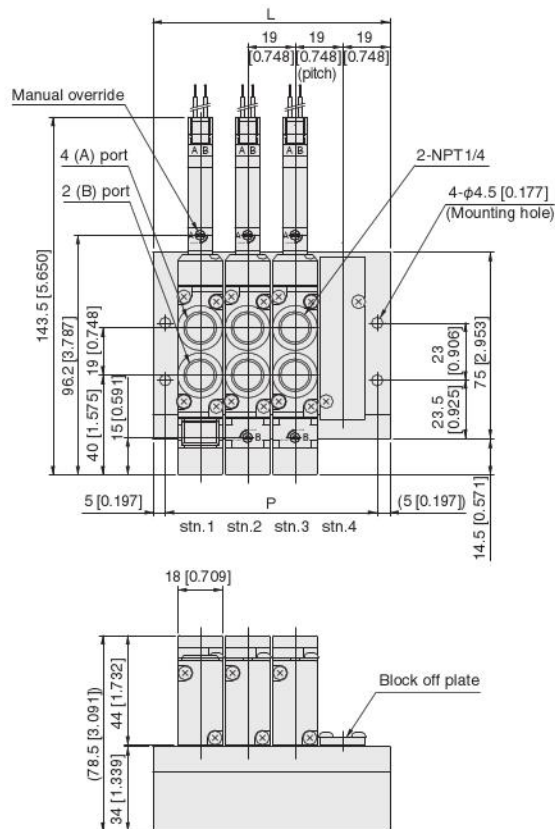
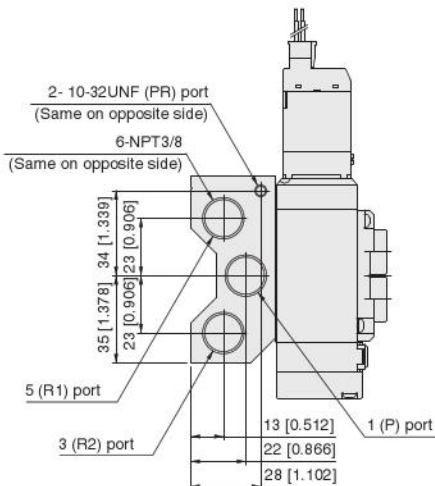

Note: The overall valve length of the T0 type is 12 mm [0.472 in] shorter (end cover side protrusion is 12 mm [0.472 in] less).



## Unit dimensions

Number of units	L	P
2	57 [2.244]	47 [1.850]
3	76 [2.992]	66 [2.598]
4	95 [3.740]	85 [3.346]
5	114 [4.488]	104 [4.094]
6	133 [5.236]	123 [4.843]
7	152 [5.984]	142 [5.591]
8	171 [6.732]	161 [6.339]
9	190 [7.480]	180 [7.087]
10	209 [8.228]	199 [7.835]
11	228 [8.976]	218 [8.583]
12	247 [9.724]	237 [9.331]
13	266 [10.472]	256 [10.079]
14	285 [11.220]	275 [10.827]
15	304 [11.969]	294 [11.575]
16	323 [12.717]	313 [12.323]
17	342 [13.465]	332 [13.071]
18	361 [14.213]	351 [13.819]
19	380 [14.961]	370 [14.567]
20	399 [15.709]	389 [15.315]

Dimensions of F18 series split manifold non-plug-in type mm [in]



**F18M** Number of valves **N** **M** Pilot specifications (Base piping type)

With manifold outlet port dual use fitting block  
S type plug connector

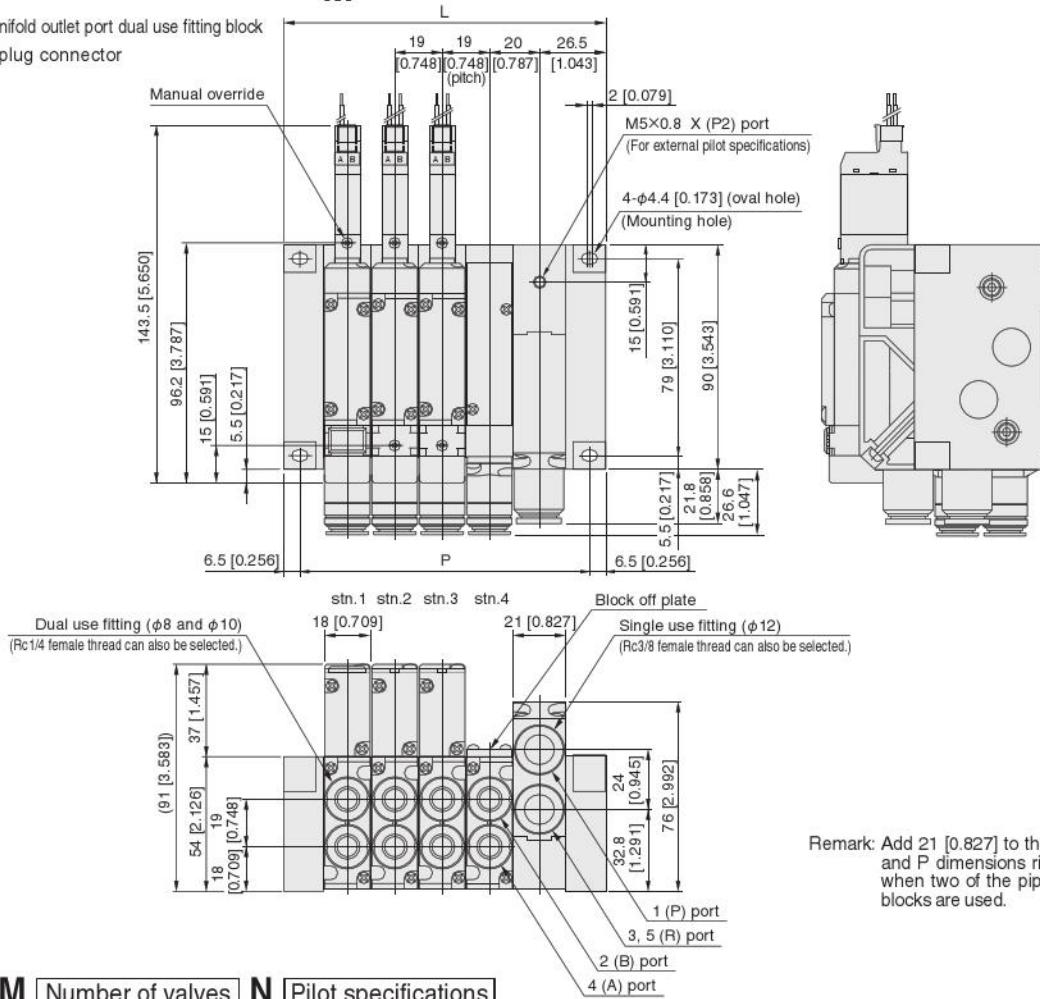

Remark: Add 21 [0.827] to the L and P dimensions right when two of the piping blocks are used.

**Unit dimensions**

Number of units	L	P
2	91 [3.583]	78 [3.071]
3	110 [4.331]	97 [3.819]
4	129 [5.079]	116 [4.567]
5	148 [5.827]	135 [5.315]
6	167 [6.575]	154 [6.063]
7	186 [7.323]	173 [6.811]
8	205 [8.071]	192 [7.559]
9	224 [8.819]	211 [8.307]
10	243 [9.567]	230 [9.055]
11	262 [10.315]	249 [9.803]
12	281 [11.063]	268 [10.551]
13	300 [11.811]	287 [11.299]
14	319 [12.559]	306 [12.047]
15	338 [13.307]	325 [12.795]
16	357 [14.055]	344 [13.543]
17	376 [14.803]	363 [14.291]
18	395 [15.551]	382 [15.039]
19	414 [16.299]	401 [15.787]
20	433 [17.047]	420 [16.535]

**F18M** Number of valves **N** Pilot specifications

(Direct piping type)

With valve outlet port dual use fitting block  
S type plug connector

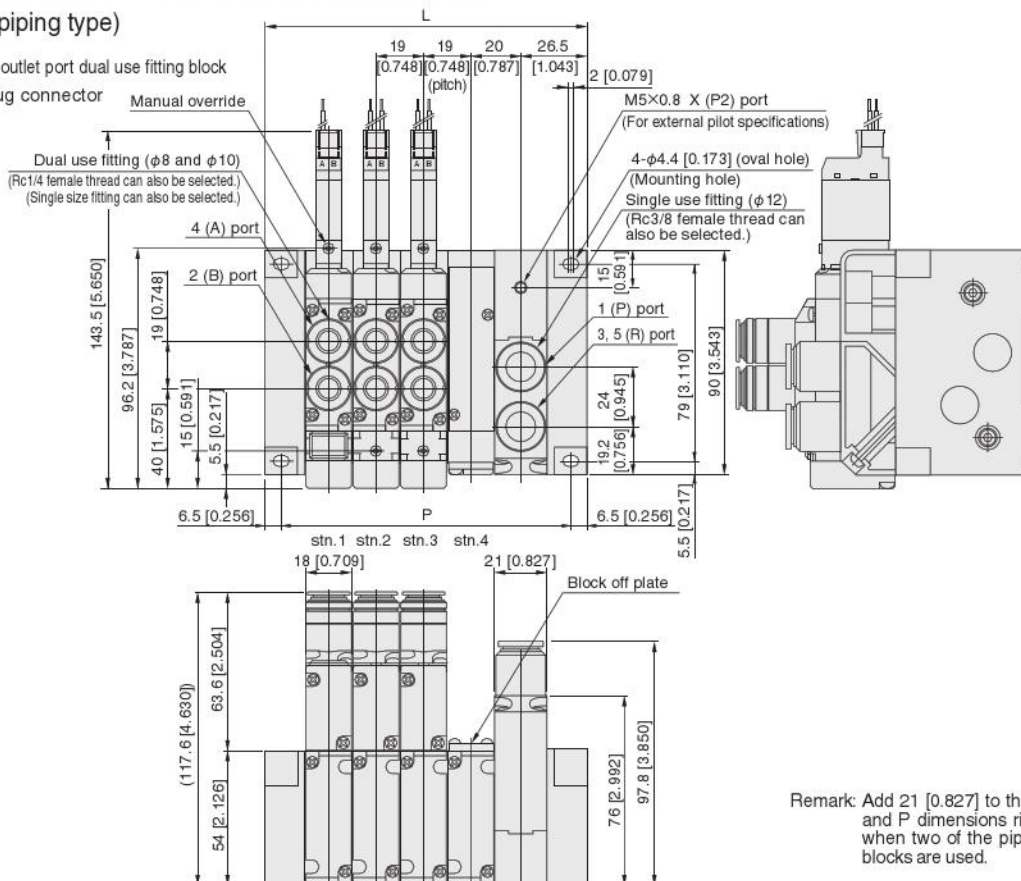

Remark: Add 21 [0.827] to the L and P dimensions right when two of the piping blocks are used.



**Unit dimensions**

Number of units	L	P
2	91 [3.583]	78 [3.071]
3	110 [4.331]	97 [3.819]
4	129 [5.079]	116 [4.567]
5	148 [5.827]	135 [5.315]
6	167 [6.575]	154 [6.063]
7	186 [7.323]	173 [6.811]
8	205 [8.071]	192 [7.559]
9	224 [8.819]	211 [8.307]
10	243 [9.567]	230 [9.055]
11	262 [10.315]	249 [9.803]
12	281 [11.063]	268 [10.551]
13	300 [11.811]	287 [11.299]
14	319 [12.559]	306 [12.047]
15	338 [13.307]	325 [12.795]
16	357 [14.055]	344 [13.543]
17	376 [14.803]	363 [14.291]
18	395 [15.551]	382 [15.039]
19	414 [16.299]	401 [15.787]
20	433 [17.047]	420 [16.535]

Note: The overall valve length of the T0 type is 12 mm [0.472 in] shorter (end cover side protrusion is 12 mm [0.472 in] less).

Dimensions of F18 series split manifold non-plug-in type mm [in]



**F18M** Number of valves **NHL** Pilot specifications (Base piping type)

With manifold outlet port female thread block  
S type plug connector

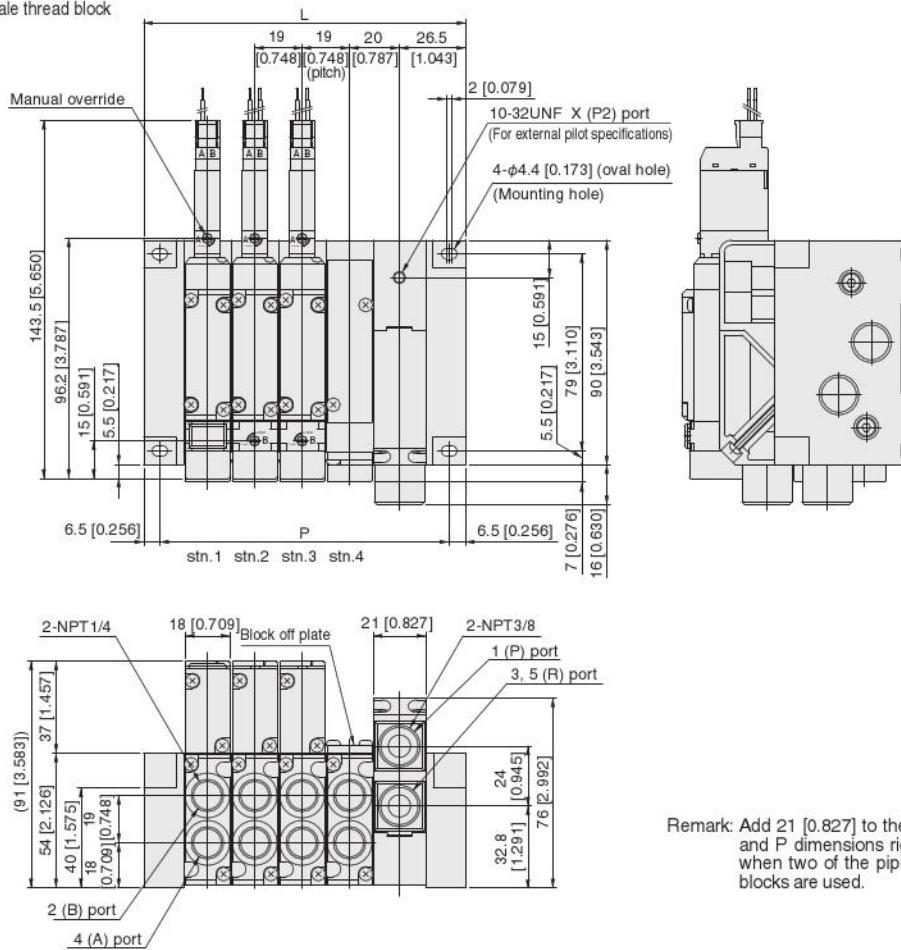

Remark: Add 21 [0.827] to the L and P dimensions right when two of the piping blocks are used.

**Unit dimensions**

Number of units	L	P
2	91 [3.583]	78 [3.071]
3	110 [4.331]	97 [3.819]
4	129 [5.079]	116 [4.567]
5	148 [5.827]	135 [5.315]
6	167 [6.575]	154 [6.063]
7	186 [7.323]	173 [6.811]
8	205 [8.071]	192 [7.559]
9	224 [8.819]	211 [8.307]
10	243 [9.567]	230 [9.055]
11	262 [10.315]	249 [9.803]
12	281 [11.063]	268 [10.551]
13	300 [11.811]	287 [11.299]
14	319 [12.559]	306 [12.047]
15	338 [13.307]	325 [12.795]
16	357 [14.055]	344 [13.543]
17	376 [14.803]	363 [14.291]
18	395 [15.551]	382 [15.039]
19	414 [16.299]	401 [15.787]
20	433 [17.047]	420 [16.535]



**Unit dimensions**

Number of units	L	P
2	91 [3.583]	78 [3.071]
3	110 [4.331]	97 [3.819]
4	129 [5.079]	116 [4.567]
5	148 [5.827]	135 [5.315]
6	167 [6.575]	154 [6.063]
7	186 [7.323]	173 [6.811]
8	205 [8.071]	192 [7.559]
9	224 [8.819]	211 [8.307]
10	243 [9.567]	230 [9.055]
11	262 [10.315]	249 [9.803]
12	281 [11.063]	268 [10.551]
13	300 [11.811]	287 [11.299]
14	319 [12.559]	306 [12.047]
15	338 [13.307]	325 [12.795]
16	357 [14.055]	344 [13.543]
17	376 [14.803]	363 [14.291]
18	395 [15.551]	382 [15.039]
19	414 [16.299]	401 [15.787]
20	433 [17.047]	420 [16.535]

Remark: Add 21 [0.827] to the L and P dimensions right when two of the piping blocks are used.

**F18M** Number of valves **NH** Pilot specifications (Direct piping type)

With valve outlet port female thread block  
S type plug connector

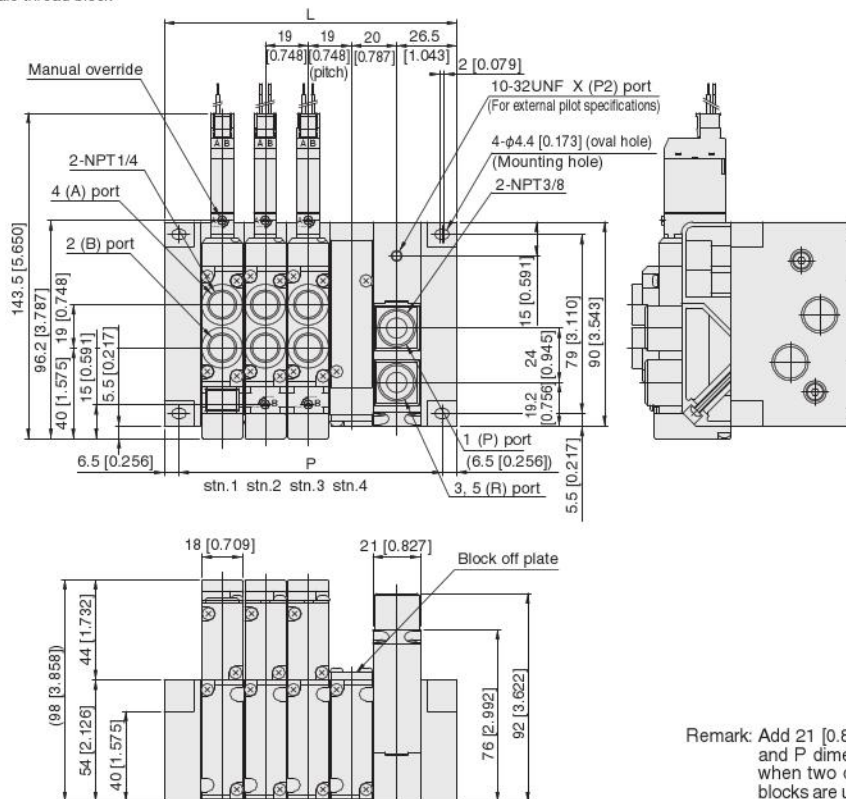

Remark: Add 21 [0.827] to the L and P dimensions right when two of the piping blocks are used.

# Dimensions of F18 series split manifold plug-in type mm [in]

Combination of F18MPJ and F18-CONT

## F18M Number of valves P M Pilot specifications (Base piping type)

With manifold outlet port dual use fitting block  
Flat cable connector 10-pin specifications

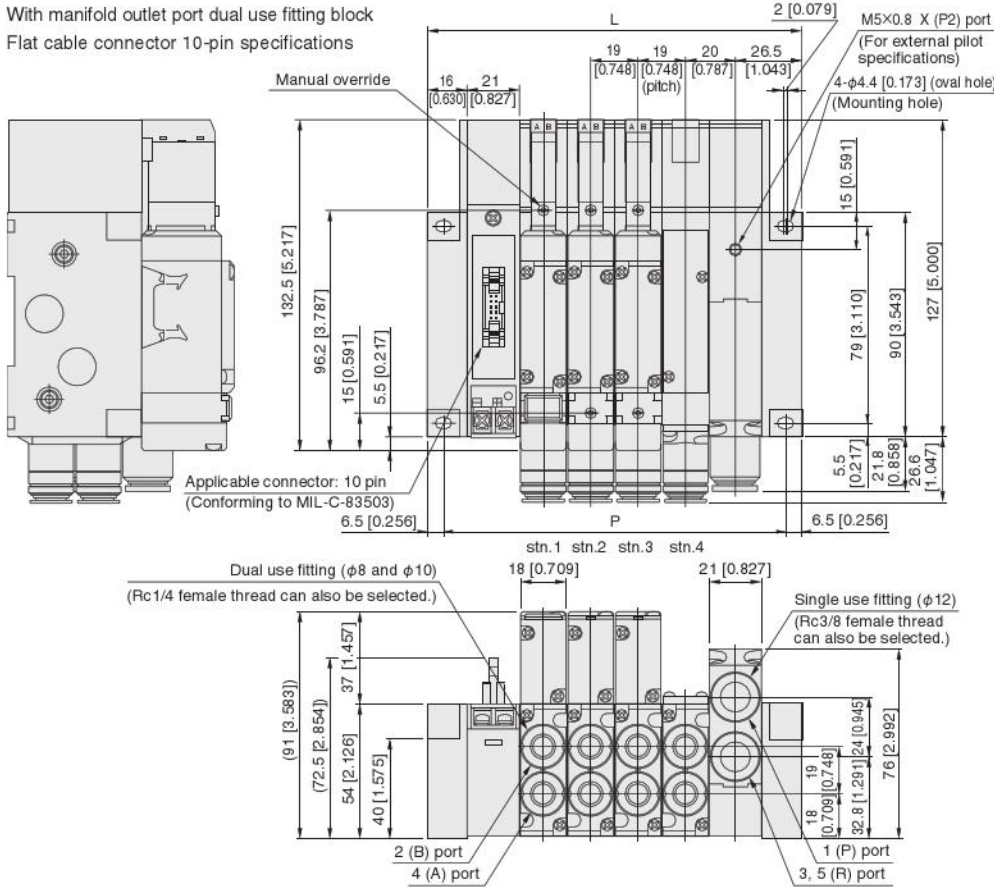

## Female thread specifications

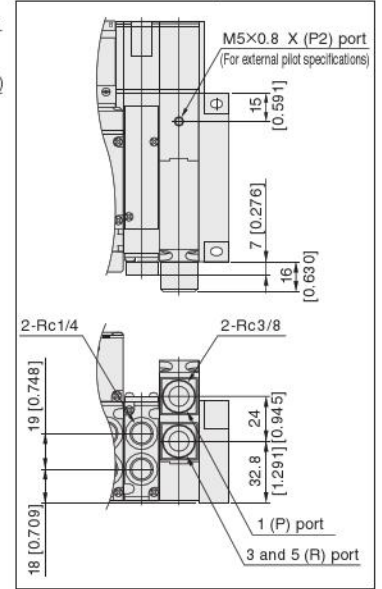

## Unit dimensions

Number of units	L	P
2	112 [4.409]	99 [3.898]
3	131 [5.157]	118 [4.646]
4	150 [5.906]	137 [5.394]
5	169 [6.654]	156 [6.142]
6	188 [7.402]	175 [6.890]
7	207 [8.150]	194 [7.638]
8	226 [8.898]	213 [8.386]

Remark: Add 21 [0.827] to the L and P dimensions above when two of the piping blocks are used.

## F18M Number of valves P M Pilot specifications (Base piping type)

With manifold outlet port dual use fitting block  
Flat cable connector 20-pin specifications

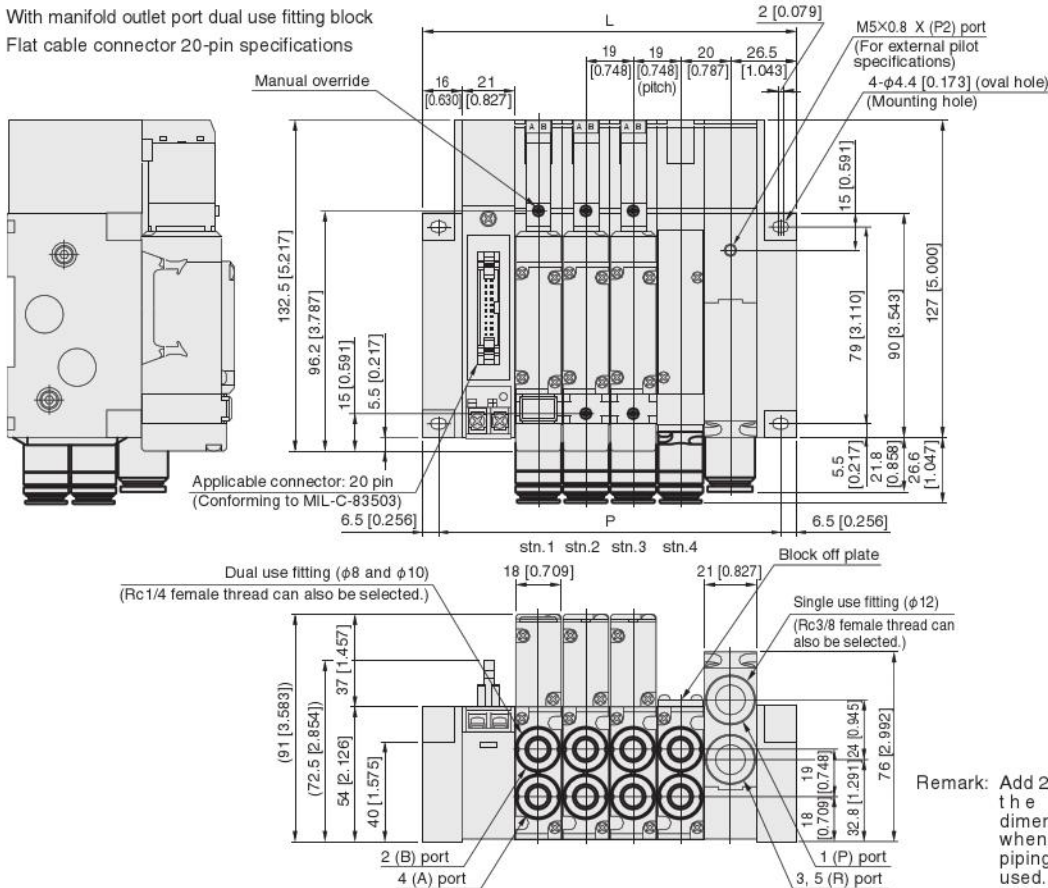

## Unit dimensions

Number of units	L	P
2	112 [4.409]	99 [3.898]
3	131 [5.157]	118 [4.646]
4	150 [5.906]	137 [5.394]
5	169 [6.654]	156 [6.142]
6	188 [7.402]	175 [6.890]
7	207 [8.150]	194 [7.638]
8	226 [8.898]	213 [8.386]
9	245 [9.646]	232 [9.134]
10	264 [10.394]	251 [9.882]
11	283 [11.142]	270 [10.630]
12	302 [11.890]	289 [11.378]
13	321 [12.638]	308 [12.126]
14	340 [13.386]	327 [12.874]
15	359 [14.134]	346 [13.622]
16	378 [14.882]	365 [14.370]

Remark: Add 21 [0.827] to the L and P dimensions right when two of the piping blocks are used.

Dimensions of F18 series split manifold plug-in type mm [in]

 Combination of F18MPJ and F18-CONT

**F18M** [Number of valves] **P M J** [Pilot specifications] (Base piping type)

With manifold outlet port dual use fitting block  
Flat cable connector 26-pin specifications

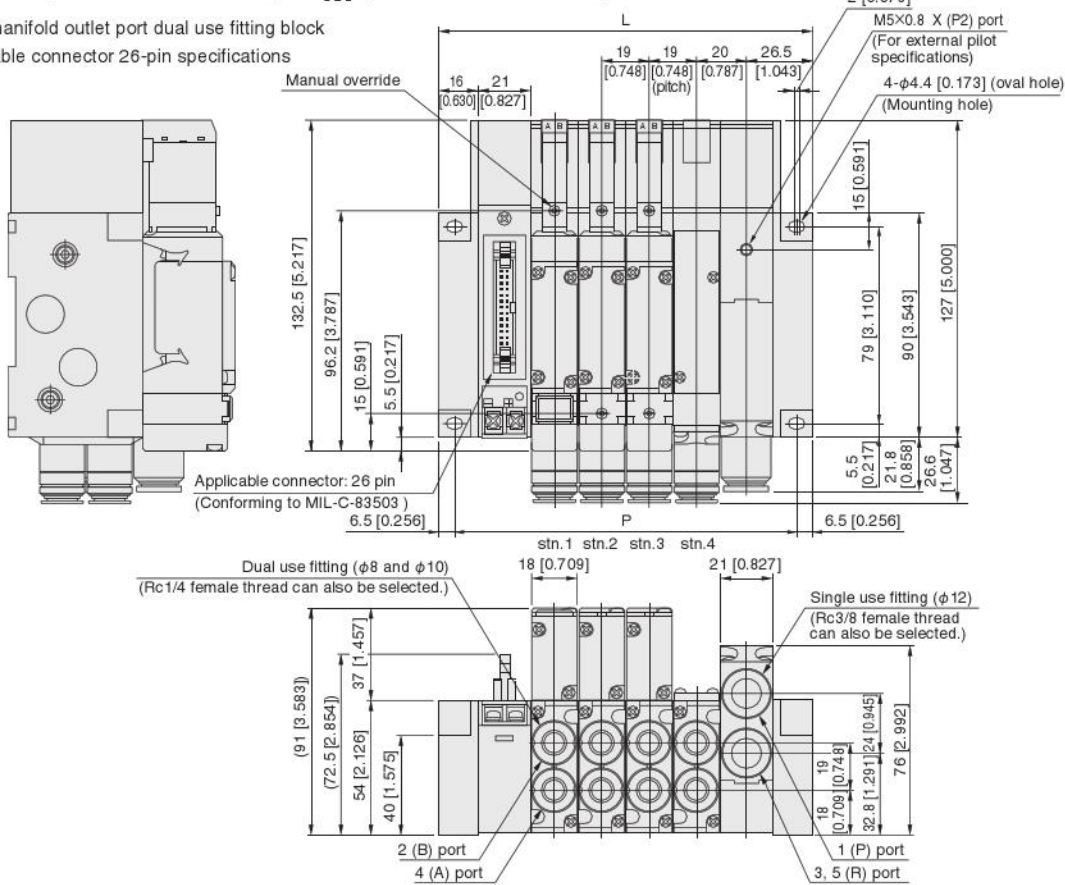

**Unit dimensions**

Number of units	L	P
2	112 [4.409]	99 [3.898]
3	131 [5.157]	118 [4.646]
4	150 [5.906]	137 [5.394]
5	169 [6.654]	156 [6.142]
6	188 [7.402]	175 [6.890]
7	207 [8.150]	194 [7.638]
8	226 [8.898]	213 [8.386]
9	245 [9.646]	232 [9.134]
10	264 [10.394]	251 [9.882]
11	283 [11.142]	270 [10.630]
12	302 [11.890]	289 [11.378]
13	321 [12.638]	308 [12.126]
14	340 [13.386]	327 [12.874]
15	359 [14.134]	346 [13.622]
16	378 [14.882]	365 [14.370]
17	397 [15.630]	384 [15.118]
18	416 [16.378]	403 [15.866]
19	435 [17.126]	422 [16.614]
20	454 [17.874]	441 [17.362]

**F18M** [Number of valves] **P M J** [Pilot specifications] (Base piping type)

With manifold outlet port dual use fitting block  
D-sub connector 25-pin specifications

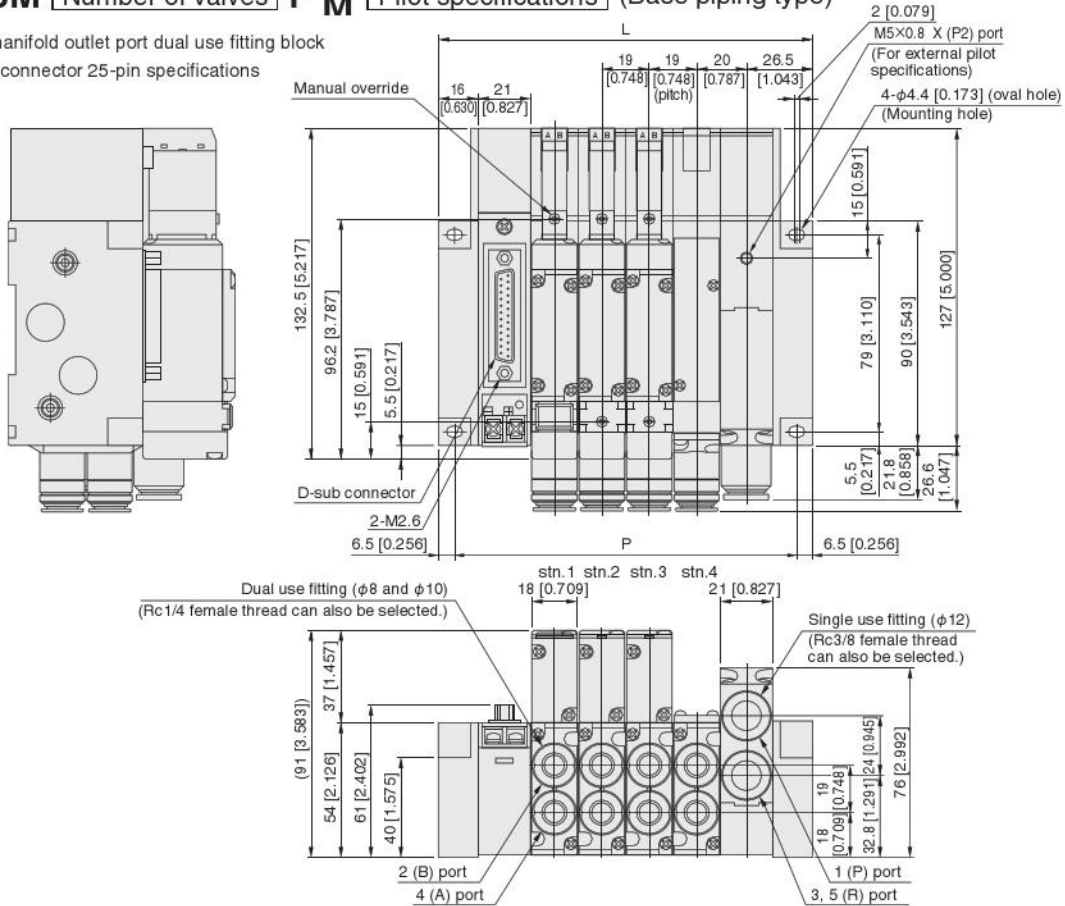

**Unit dimensions**

Number of units	L	P
2	112 [4.409]	99 [3.898]
3	131 [5.157]	118 [4.646]
4	150 [5.906]	137 [5.394]
5	169 [6.654]	156 [6.142]
6	188 [7.402]	175 [6.890]
7	207 [8.150]	194 [7.638]
8	226 [8.898]	213 [8.386]
9	245 [9.646]	232 [9.134]
10	264 [10.394]	251 [9.882]
11	283 [11.142]	270 [10.630]
12	302 [11.890]	289 [11.378]
13	321 [12.638]	308 [12.126]
14	340 [13.386]	327 [12.874]
15	359 [14.134]	346 [13.622]
16	378 [14.882]	365 [14.370]
17	397 [15.630]	384 [15.118]
18	416 [16.378]	403 [15.866]
19	435 [17.126]	422 [16.614]
20	454 [17.874]	441 [17.362]

# Dimensions of F18 series split manifold plug-in type mm [in]



Combination of F18MPJ and F18-CONT

## F18M Number of valves P M Pilot specifications (Base piping type)

With manifold outlet port dual use fitting block  
Terminal block type

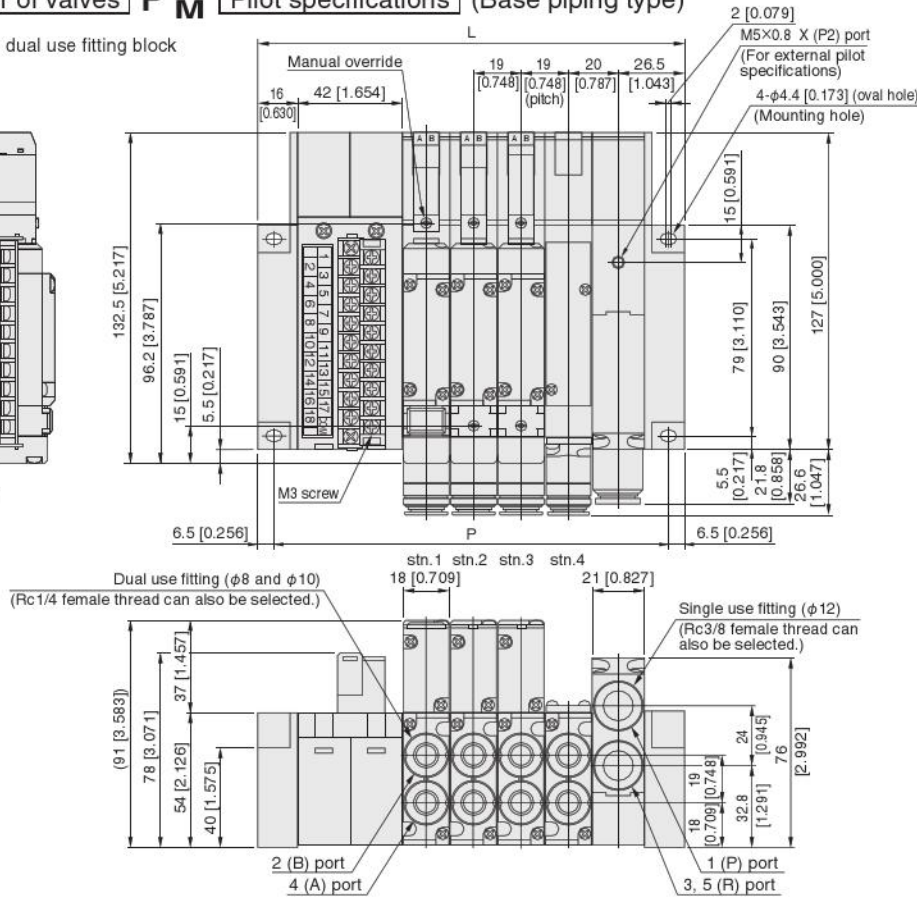
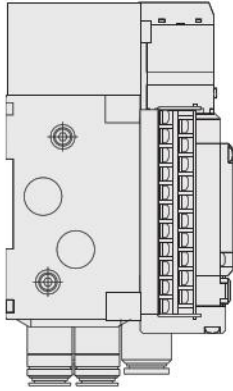

### Unit dimensions

Number of units	L	P
2	133 [5.236]	120 [4.724]
3	152 [5.984]	139 [5.472]
4	171 [6.732]	158 [6.220]
5	190 [7.480]	177 [6.969]
6	209 [8.228]	196 [7.717]
7	228 [8.976]	215 [8.465]
8	247 [9.724]	234 [9.213]
9	266 [10.472]	253 [9.961]
10	285 [11.220]	272 [10.709]
11	304 [11.969]	291 [11.457]
12	323 [12.717]	310 [12.205]
13	342 [13.465]	329 [12.953]
14	361 [14.213]	348 [13.701]
15	380 [14.961]	367 [14.449]
16	399 [15.709]	386 [15.197]
17	418 [16.457]	405 [15.945]
18	437 [17.205]	424 [16.693]

Remark: Add 21 [0.827] to the L and P dimensions above when two of the piping blocks are used.

## F18M Number of valves PL Pilot specifications (Base piping type)

With manifold outlet port single use fitting block  
Flat cable connector 20-pin specifications

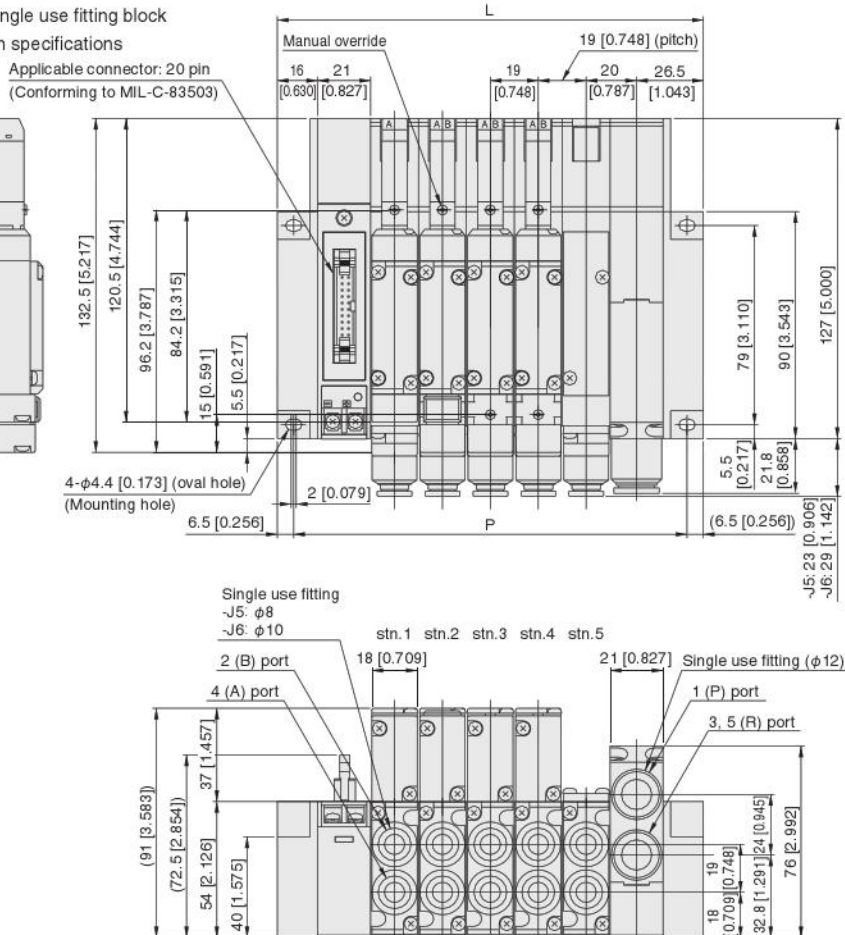
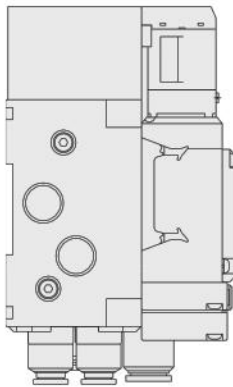

### Unit dimensions

Number of units	L	P
2	112 [4.409]	99 [3.898]
3	131 [5.157]	118 [4.646]
4	150 [5.906]	137 [5.394]
5	169 [6.654]	156 [6.142]
6	188 [7.402]	175 [6.890]
7	207 [8.150]	194 [7.638]
8	226 [8.898]	213 [8.386]
9	245 [9.646]	232 [9.134]
10	264 [10.394]	251 [9.882]
11	283 [11.142]	270 [10.630]
12	302 [11.890]	289 [11.378]
13	321 [12.638]	308 [12.126]
14	340 [13.386]	327 [12.874]
15	359 [14.134]	346 [13.622]
16	378 [14.882]	365 [14.370]
17	397 [15.630]	384 [15.118]
18	416 [16.378]	403 [15.866]
19	435 [17.126]	422 [16.614]
20	454 [17.874]	441 [17.362]

Remark: Add 21 [0.827] to the L and P dimensions right when two of the piping blocks are used.



# Dimensions of F18 series split manifold plug-in type mm [in]

## F18M Number of valves PHL Pilot specifications (Base piping type)

Combination of F18MPJ and F18-CONT

With manifold outlet port female thread block  
Flat cable connector 20-pin specifications

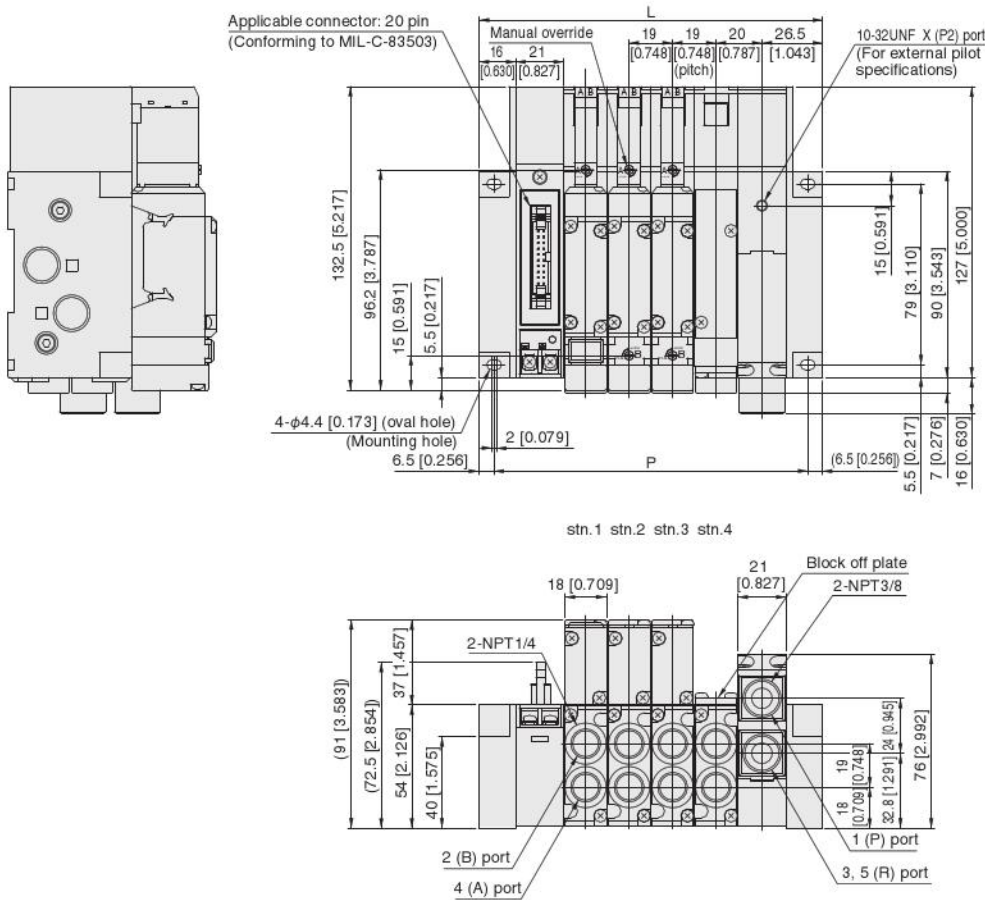

### Unit dimensions

Number of units	L	P
2	112 [4.409]	99 [3.898]
3	131 [5.157]	118 [4.646]
4	150 [5.906]	137 [5.394]
5	169 [6.654]	156 [6.142]
6	188 [7.402]	175 [6.890]
7	207 [8.150]	194 [7.638]
8	226 [8.898]	213 [8.386]
9	245 [9.646]	232 [9.134]
10	264 [10.394]	251 [9.882]
11	283 [11.142]	270 [10.630]
12	302 [11.890]	289 [11.378]
13	321 [12.638]	308 [12.126]
14	340 [13.386]	327 [12.874]
15	359 [14.134]	346 [13.622]
16	378 [14.882]	365 [14.370]

Remark: Add 21 [0.827] to the L and P dimensions above when two of the piping blocks are used.

## F18M Number of valves PH Pilot specifications (Direct piping type)

With valve outlet port female thread block  
Flat cable connector 20-pin specifications

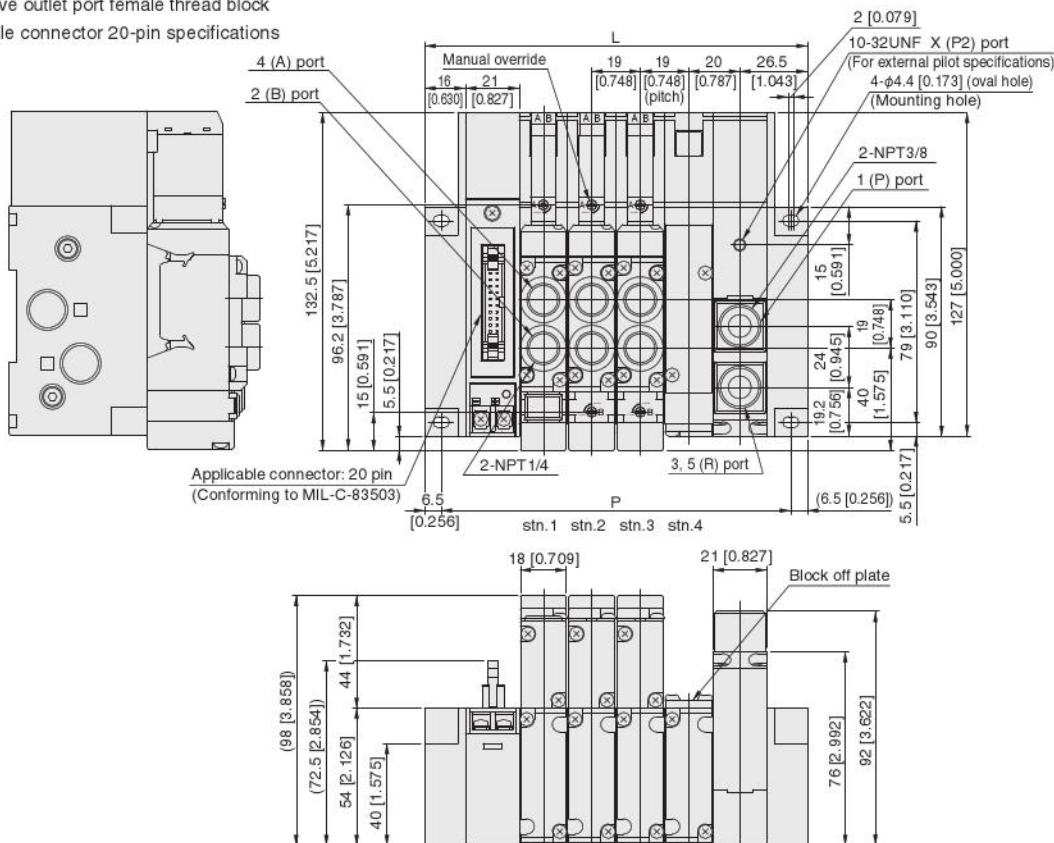

### Unit dimensions

Number of units	L	P
2	112 [4.409]	99 [3.898]
3	131 [5.157]	118 [4.646]
4	150 [5.906]	137 [5.394]
5	169 [6.654]	156 [6.142]
6	188 [7.402]	175 [6.890]
7	207 [8.150]	194 [7.638]
8	226 [8.898]	213 [8.386]
9	245 [9.646]	232 [9.134]
10	264 [10.394]	251 [9.882]
11	283 [11.142]	270 [10.630]
12	302 [11.890]	289 [11.378]
13	321 [12.638]	308 [12.126]
14	340 [13.386]	327 [12.874]
15	359 [14.134]	346 [13.622]
16	378 [14.882]	365 [14.370]

Remark: Add 21 [0.827] to the L and P dimensions above when two of the piping blocks are used.

F18 SERIES

# Dimensions of F18 series split manifold plug-in type mm [in]

 Combination of F18MPJ and F18-CONT

## F18M Number of valves PHL Pilot specifications (Base piping type)

With manifold outlet port female thread block  
Flat cable connector 26-pin specifications

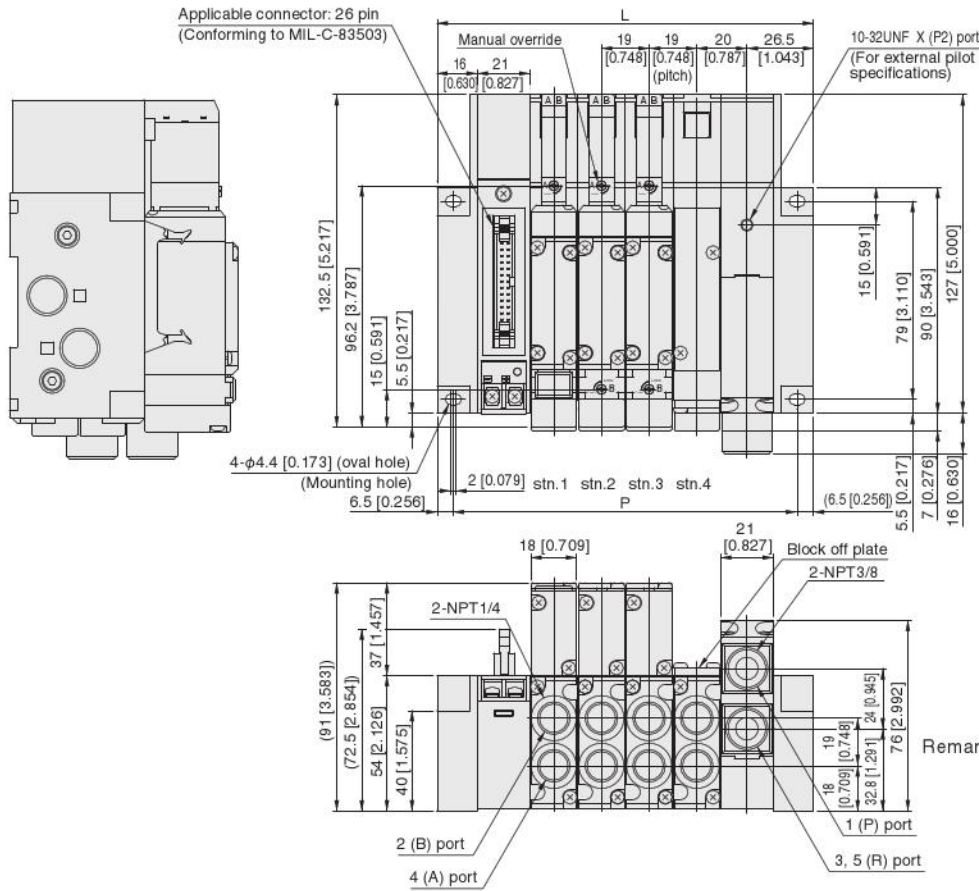

### Unit dimensions

Number of units	L	P
2	112 [4.409]	99 [3.898]
3	131 [5.157]	118 [4.646]
4	150 [5.906]	137 [5.394]
5	169 [6.654]	156 [6.142]
6	188 [7.402]	175 [6.890]
7	207 [8.150]	194 [7.638]
8	226 [8.898]	213 [8.386]
9	245 [9.646]	232 [9.134]
10	264 [10.394]	251 [9.882]
11	283 [11.142]	270 [10.630]
12	302 [11.890]	289 [11.378]
13	321 [12.638]	308 [12.126]
14	340 [13.386]	327 [12.874]
15	359 [14.134]	346 [13.622]
16	378 [14.882]	365 [14.370]
17	397 [15.630]	384 [15.118]
18	416 [16.378]	403 [15.866]
19	435 [17.126]	422 [16.614]
20	454 [17.874]	441 [17.362]

 Combination of F18MPJ and F18-CONT

## F18M Number of valves PH Pilot specifications (Direct piping type)

With valve outlet port female thread block  
Flat cable connector 26-pin specifications

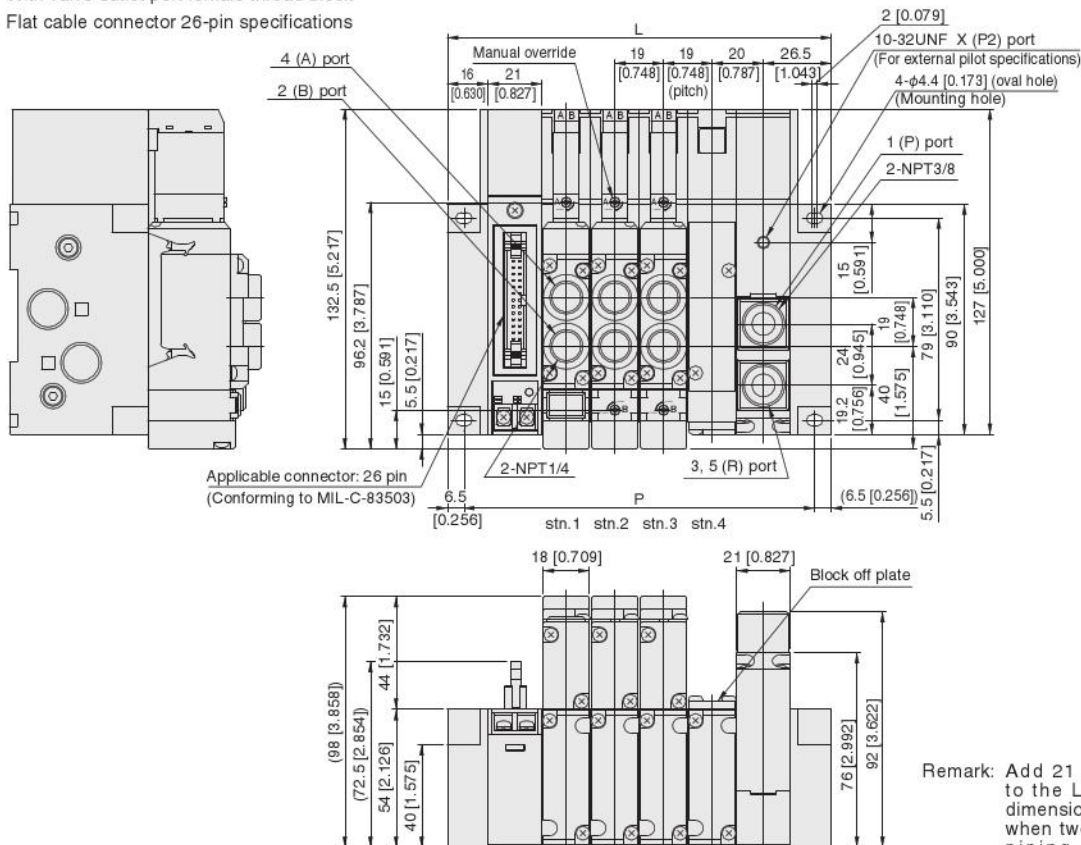

### Unit dimensions

Number of units	L	P
2	112 [4.409]	99 [3.898]
3	131 [5.157]	118 [4.646]
4	150 [5.906]	137 [5.394]
5	169 [6.654]	156 [6.142]
6	188 [7.402]	175 [6.890]
7	207 [8.150]	194 [7.638]
8	226 [8.898]	213 [8.386]
9	245 [9.646]	232 [9.134]
10	264 [10.394]	251 [9.882]
11	283 [11.142]	270 [10.630]
12	302 [11.890]	289 [11.378]
13	321 [12.638]	308 [12.126]
14	340 [13.386]	327 [12.874]
15	359 [14.134]	346 [13.622]
16	378 [14.882]	365 [14.370]
17	397 [15.630]	384 [15.118]
18	416 [16.378]	403 [15.866]
19	435 [17.126]	422 [16.614]
20	454 [17.874]	441 [17.362]

Dimensions of F18 series split manifold plug-in type mm [in]

**F18M** Number of valves **PHL** Pilot specifications (Base piping type)

With manifold outlet port female thread block

D-sub connector 25-pin specifications Manual override

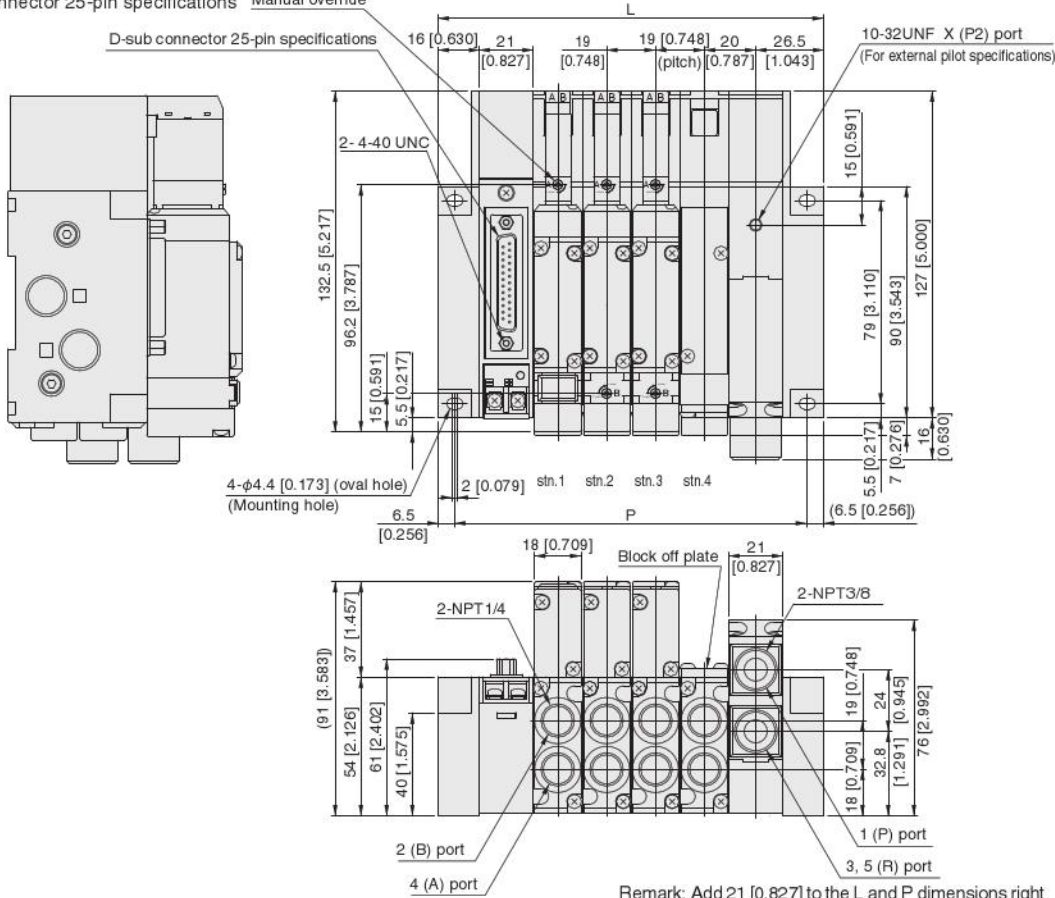

Remark: Add 21 [0.827] to the L and P dimensions right when two of the piping blocks are used.

Unit dimensions

Number of units	L	P
2	112 [4.409]	99 [3.898]
3	131 [5.157]	118 [4.646]
4	150 [5.906]	137 [5.394]
5	169 [6.654]	156 [6.142]
6	188 [7.402]	175 [6.890]
7	207 [8.150]	194 [7.638]
8	226 [8.898]	213 [8.386]
9	245 [9.646]	232 [9.134]
10	264 [10.394]	251 [9.882]
11	283 [11.142]	270 [10.630]
12	302 [11.890]	289 [11.378]
13	321 [12.638]	308 [12.126]
14	340 [13.386]	327 [12.874]
15	359 [14.134]	346 [13.622]
16	378 [14.882]	365 [14.370]
17	397 [15.630]	384 [15.118]
18	416 [16.378]	403 [15.866]
19	435 [17.126]	422 [16.614]
20	454 [17.874]	441 [17.362]

Remark

**F18M** Number of valves **PH** Pilot specifications (Direct piping type)

With valve outlet port female thread block

D-sub connector 25-pin specifications

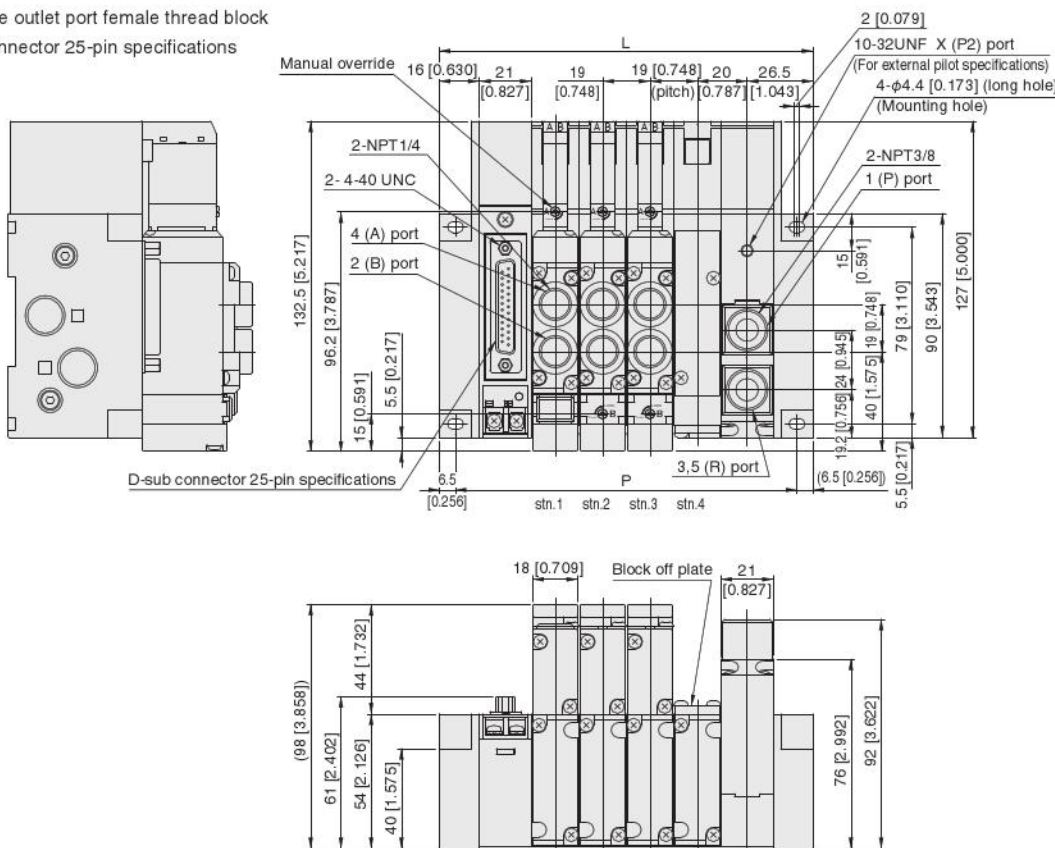

Remark: Add 21 [0.827] to the L and P dimensions right when two of the piping blocks are used.

Unit dimensions

Number of units	L	P
2	112 [4.409]	99 [3.898]
3	131 [5.157]	118 [4.646]
4	150 [5.906]	137 [5.394]
5	169 [6.654]	156 [6.142]
6	188 [7.402]	175 [6.890]
7	207 [8.150]	194 [7.638]
8	226 [8.898]	213 [8.386]
9	245 [9.646]	232 [9.134]
10	264 [10.394]	251 [9.882]
11	283 [11.142]	270 [10.630]
12	302 [11.890]	289 [11.378]
13	321 [12.638]	308 [12.126]
14	340 [13.386]	327 [12.874]
15	359 [14.134]	346 [13.622]
16	378 [14.882]	365 [14.370]
17	397 [15.630]	384 [15.118]
18	416 [16.378]	403 [15.866]
19	435 [17.126]	422 [16.614]
20	454 [17.874]	441 [17.362]

Remark

F18 SERIES

Dimensions of F18 series split manifold plug-in type mm [in]

**F18M** [Number of valves] **PHL** [Pilot specifications] (Base piping type)

With manifold outlet port female thread block  
D-sub connector 37-pin specifications

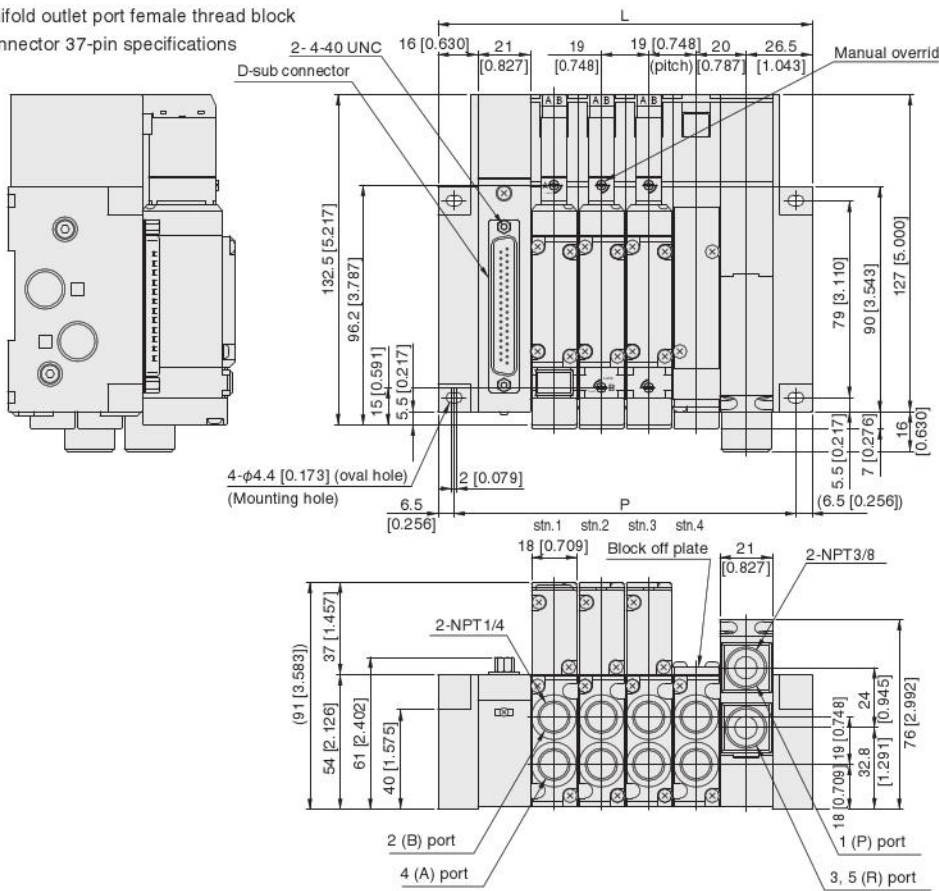

Remark: Add 21 [0.827] to the L and P dimensions right when two of the piping blocks are used.

Unit dimensions

Number of units	L	P
2	112 [4.409]	99 [3.898]
3	131 [5.157]	118 [4.646]
4	150 [5.906]	137 [5.394]
5	169 [6.654]	156 [6.142]
6	188 [7.402]	175 [6.890]
7	207 [8.150]	194 [7.638]
8	226 [8.898]	213 [8.386]
9	245 [9.646]	232 [9.134]
10	264 [10.394]	251 [9.882]
11	283 [11.142]	270 [10.630]
12	302 [11.890]	289 [11.378]
13	321 [12.638]	308 [12.126]
14	340 [13.386]	327 [12.874]
15	359 [14.134]	346 [13.622]
16	378 [14.882]	365 [14.370]
17	397 [15.630]	384 [15.118]
18	416 [16.378]	403 [15.866]
19	435 [17.126]	422 [16.614]
20	454 [17.874]	441 [17.362]

Remark

**F18M** [Number of valves] **PH** [Pilot specifications] (Direct piping type)

With valve outlet port female thread block  
D-sub connector 37-pin specifications

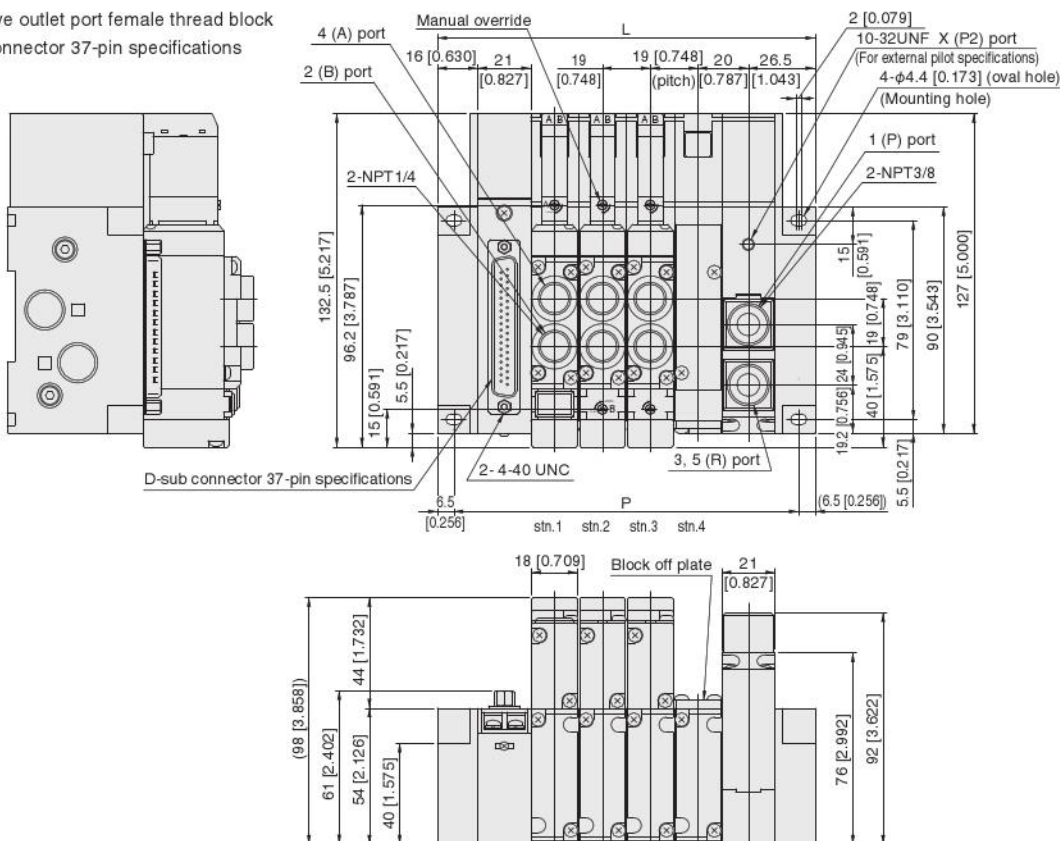

Remark: Add 21 [0.827] to the L and P dimensions right when two of the piping blocks are used.

Unit dimensions

Number of units	L	P
2	112 [4.409]	99 [3.898]
3	131 [5.157]	118 [4.646]
4	150 [5.906]	137 [5.394]
5	169 [6.654]	156 [6.142]
6	188 [7.402]	175 [6.890]
7	207 [8.150]	194 [7.638]
8	226 [8.898]	213 [8.386]
9	245 [9.646]	232 [9.134]
10	264 [10.394]	251 [9.882]
11	283 [11.142]	270 [10.630]
12	302 [11.890]	289 [11.378]
13	321 [12.638]	308 [12.126]
14	340 [13.386]	327 [12.874]
15	359 [14.134]	346 [13.622]
16	378 [14.882]	365 [14.370]
17	397 [15.630]	384 [15.118]
18	416 [16.378]	403 [15.866]
19	435 [17.126]	422 [16.614]
20	454 [17.874]	441 [17.362]

Remark

Dimensions of F18 series split manifold plug-in type mm [in]

 Combination of F18MPJ and F18-CONT

**F18M** [Number of valves] **PHL** [Pilot specifications] (Base piping type)

With manifold outlet port female thread block  
Terminal block type

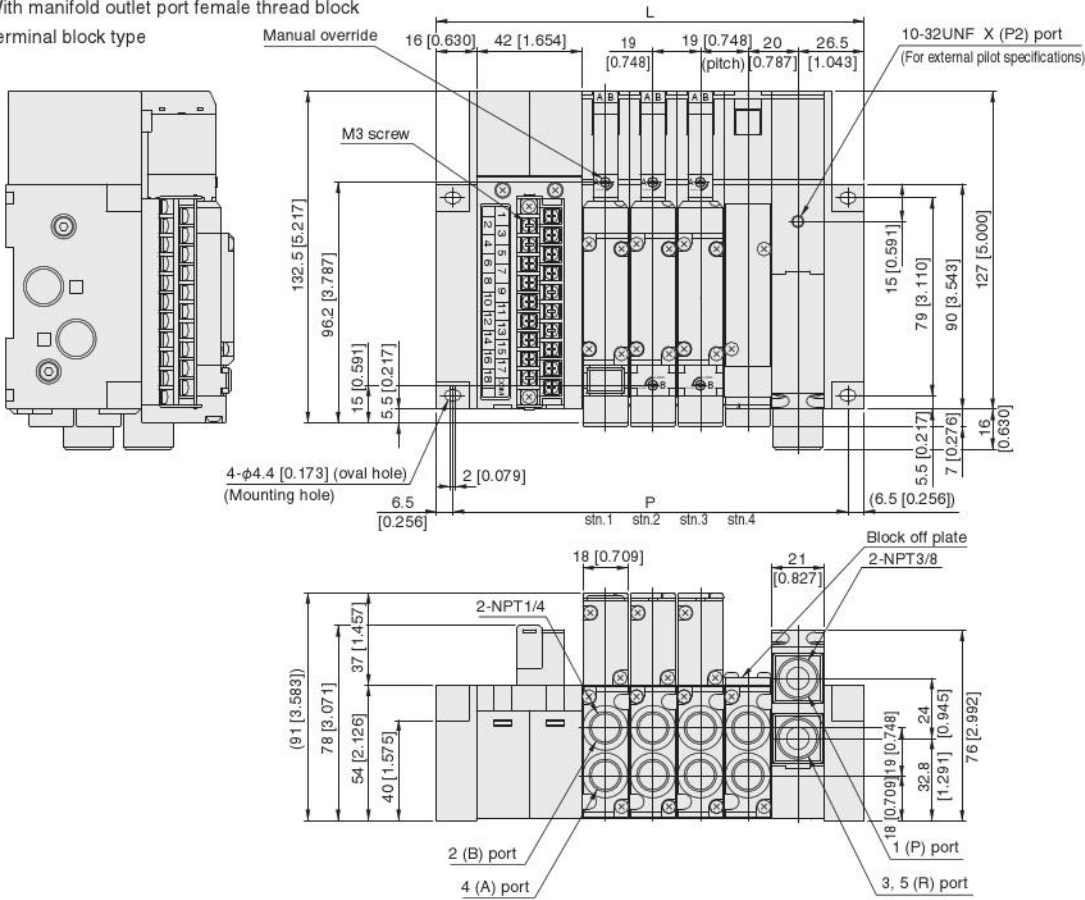

**Unit dimensions**

Number of units	L	P
2	133 [5.236]	120 [4.724]
3	152 [5.984]	139 [5.472]
4	171 [6.732]	158 [6.220]
5	190 [7.480]	177 [6.969]
6	209 [8.228]	196 [7.717]
7	228 [8.976]	215 [8.465]
8	247 [9.724]	234 [9.213]
9	266 [10.472]	253 [9.961]
10	285 [11.220]	272 [10.709]
11	304 [11.969]	291 [11.457]
12	323 [12.717]	310 [12.205]
13	342 [13.465]	329 [12.953]
14	361 [14.213]	348 [13.701]
15	380 [14.961]	367 [14.449]
16	399 [15.709]	386 [15.197]
17	418 [16.457]	405 [15.945]
18	437 [17.205]	424 [16.693]

Remark: Add 21 [0.827] to the L and P dimensions above when two of the piping blocks are used.

**F18M** [Number of valves] **PH** [Pilot specifications] (Direct piping type)

With valve outlet port female thread block  
Terminal block type

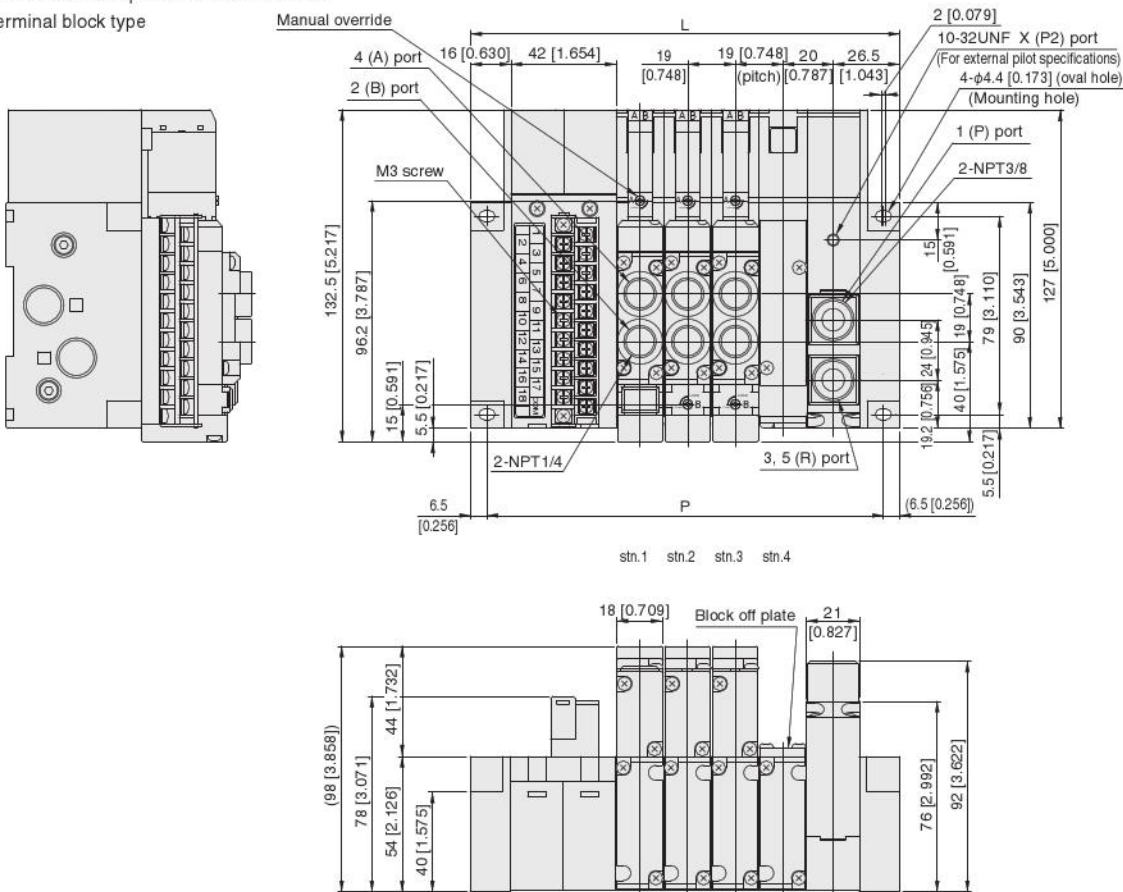

**Unit dimensions**

Number of units	L	P
2	133 [5.236]	120 [4.724]
3	152 [5.984]	139 [5.472]
4	171 [6.732]	158 [6.220]
5	190 [7.480]	177 [6.969]
6	209 [8.228]	196 [7.717]
7	228 [8.976]	215 [8.465]
8	247 [9.724]	234 [9.213]
9	266 [10.472]	253 [9.961]
10	285 [11.220]	272 [10.709]
11	304 [11.969]	291 [11.457]
12	323 [12.717]	310 [12.205]
13	342 [13.465]	329 [12.953]
14	361 [14.213]	348 [13.701]
15	380 [14.961]	367 [14.449]
16	399 [15.709]	386 [15.197]
17	418 [16.457]	405 [15.945]
18	437 [17.205]	424 [16.693]

Remark: Add 21 [0.827] to the L and P dimensions above when two of the piping blocks are used.

# Dimensions of F18 series serial transmission compatible manifold mm [In]

\* For CompoNet compatible dimensions, see page 154.

## F18M [Number of valves] S M Pilot specifications (Base piping type)



With manifold outlet port dual use fitting block  
(Models that support integrated serial transmission block)

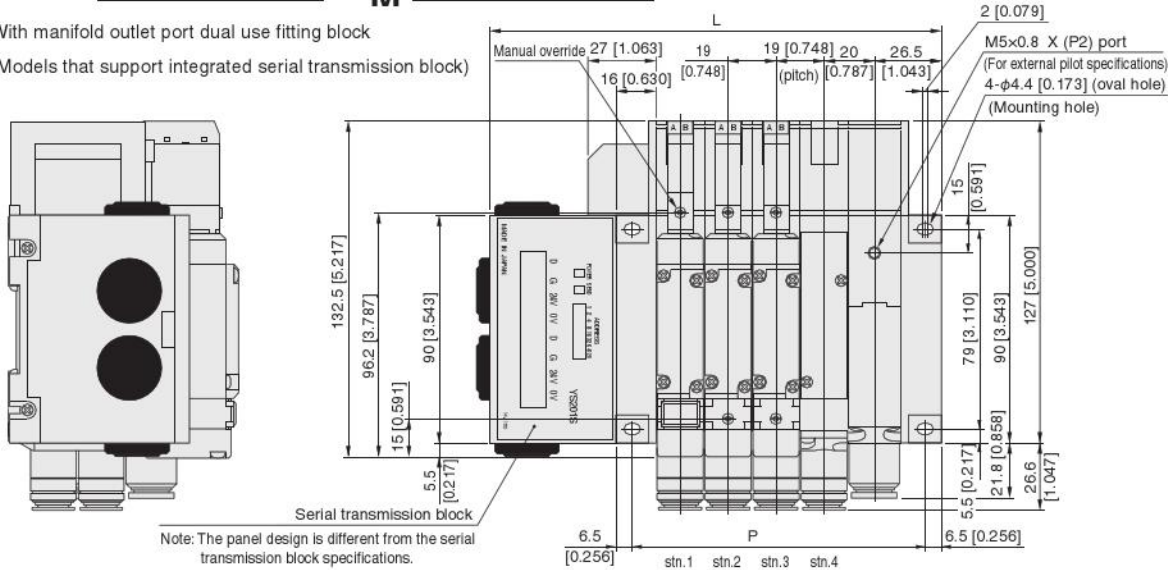

Note: The panel design is different from the serial transmission block specifications.

## F18M [Number of valves] S (Direct piping type)



With valve outlet port dual use fitting block  
(Models that support integrated serial transmission block)

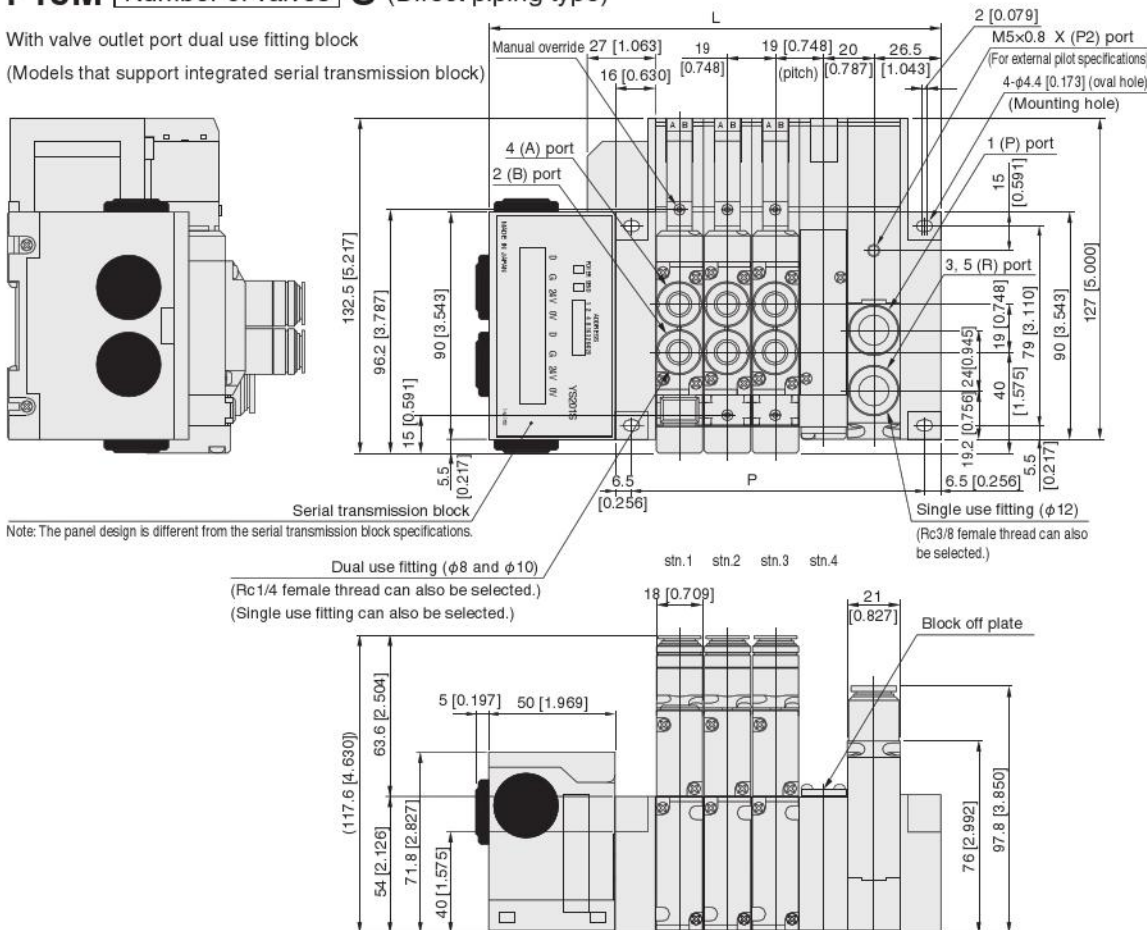

Note: The panel design is different from the serial transmission block specifications.

### Unit dimensions

Number of units	L	P
2	141 [5.551]	78 [3.071]
3	160 [6.299]	97 [3.819]
4	179 [7.047]	116 [4.567]
5	198 [7.795]	135 [5.315]
6	217 [8.543]	154 [6.063]
7	236 [9.291]	173 [6.811]
8	255 [10.039]	192 [7.559]
9	274 [10.787]	211 [8.307]
10	293 [11.535]	230 [9.055]
11	312 [12.283]	249 [9.803]
12	331 [13.031]	268 [10.551]
13	350 [13.780]	287 [11.299]
14	369 [14.528]	306 [12.047]
15	388 [15.276]	325 [12.795]
16	407 [16.024]	344 [13.543]

Remark: Add 21 [0.827] to the L and P dimensions above when two of the piping blocks are used.

# Dimensions of F18 series serial transmission compatible manifold mm [In]

\* For CompoNet compatible dimensions, see page 154.

## F18M [Number of valves] SHL Pilot specifications (Base piping type)



With manifold outlet port female thread block

(Models that support integrated serial transmission block)

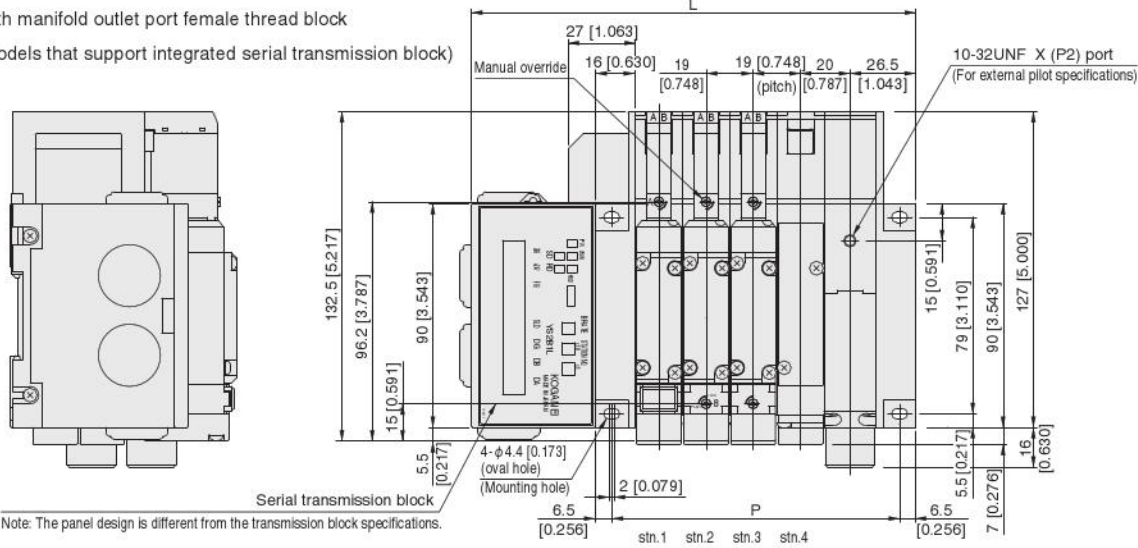

Note: The panel design is different from the transmission block specifications.

## F18M [Number of valves] S (Direct piping type)



With valve outlet port female thread block

(Models that support integrated serial transmission block)

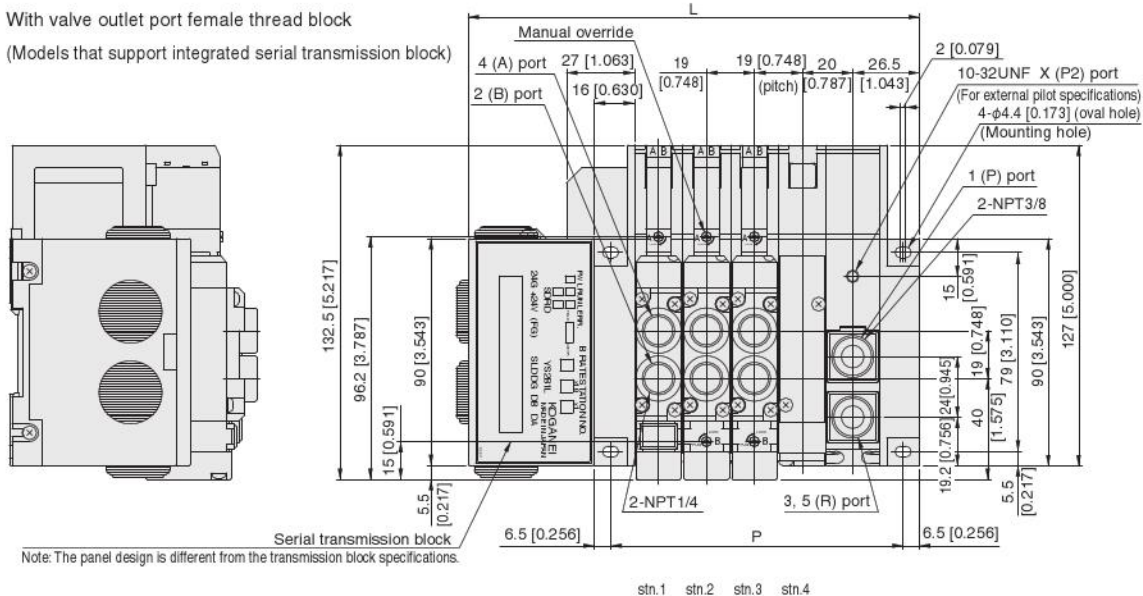

Note: The panel design is different from the transmission block specifications.

### Unit dimensions

Number of units	L	P
2	141 [5.551]	78 [3.071]
3	160 [6.299]	97 [3.819]
4	179 [7.047]	116 [4.567]
5	198 [7.795]	135 [5.315]
6	217 [8.543]	154 [6.063]
7	236 [9.291]	173 [6.811]
8	255 [10.039]	192 [7.559]
9	274 [10.787]	211 [8.307]
10	293 [11.535]	230 [9.055]
11	312 [12.283]	249 [9.803]
12	331 [13.031]	268 [10.551]
13	350 [13.780]	287 [11.299]
14	369 [14.528]	306 [12.047]
15	388 [15.276]	325 [12.795]
16	407 [16.024]	344 [13.543]

Remark: Add 21 [0.827] to the L and P dimensions above when two of the piping blocks are used.

F18 SERIES

**F18M** Number of valves **S<sub>M</sub><sup>J</sup>** Pilot specifications (Base piping type)

With manifold outlet port dual use fitting block

(Models that support stand alone transmission block)

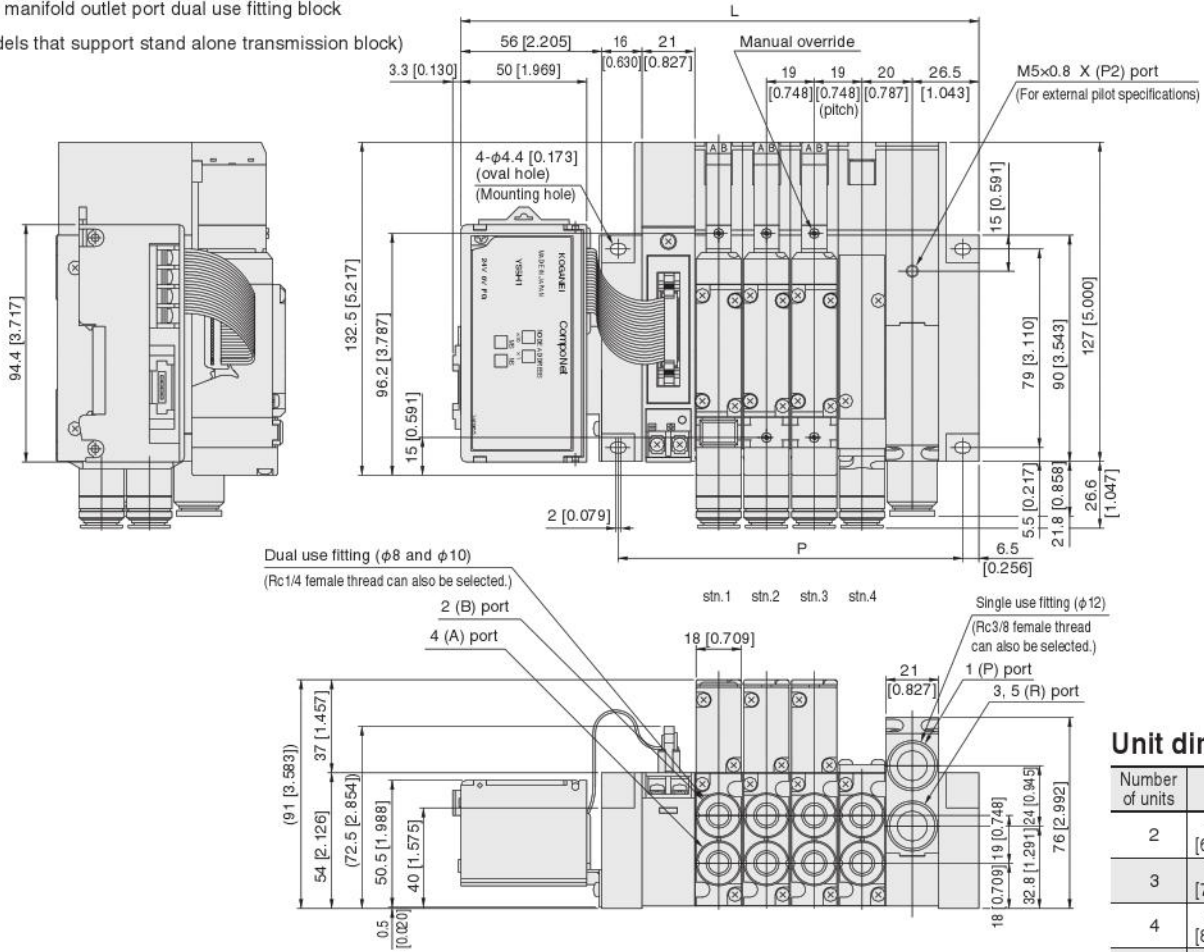

**Unit dimensions**

Number of units	L	P
2	168 [6.614]	99 [3.898]
3	187 [7.362]	118 [4.646]
4	206 [8.110]	137 [5.394]
5	225 [8.858]	156 [6.142]
6	244 [9.606]	175 [6.890]
7	263 [10.354]	194 [7.638]
8	282 [11.102]	213 [8.386]
9	301 [11.850]	232 [9.134]
10	320 [12.598]	251 [9.882]
11	339 [13.346]	270 [10.630]
12	358 [14.094]	289 [11.378]
13	377 [14.843]	308 [12.126]
14	396 [15.591]	327 [12.874]
15	415 [16.339]	346 [13.622]
16	434 [17.087]	365 [14.370]

\* The communication connectors are sold by Omron Corporation. Contact Omron Corporation for details.

**Additional Parts (available separately)**

● Muffler: **KM-J12** [for both plug-in and non-plug-in]

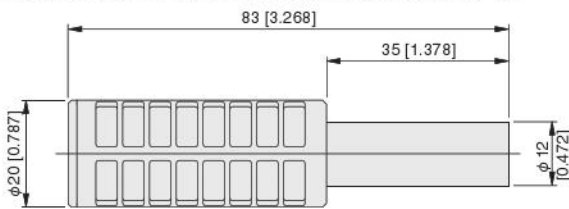

● Muffler: **KM-J8** [for individual exhaust spacer only]

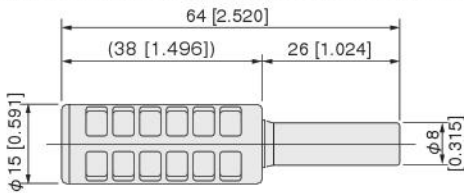

● Muffler: **KM-J10** [for individual exhaust spacer only]

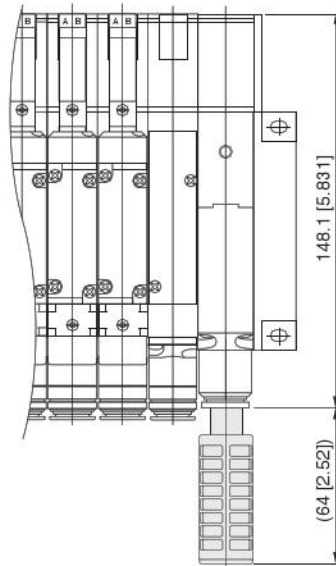
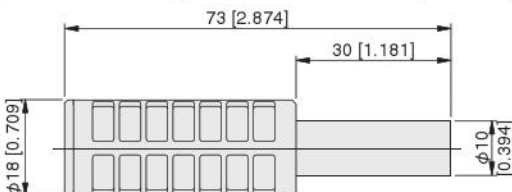

Remark: Add 21 [0.827] to the L and P dimensions above when two of the piping blocks are used.

**F18M** [Number of valves] **SHL** [Pilot specifications] (Base piping type)

With manifold outlet port female thread block

(Models that support stand alone transmission block)

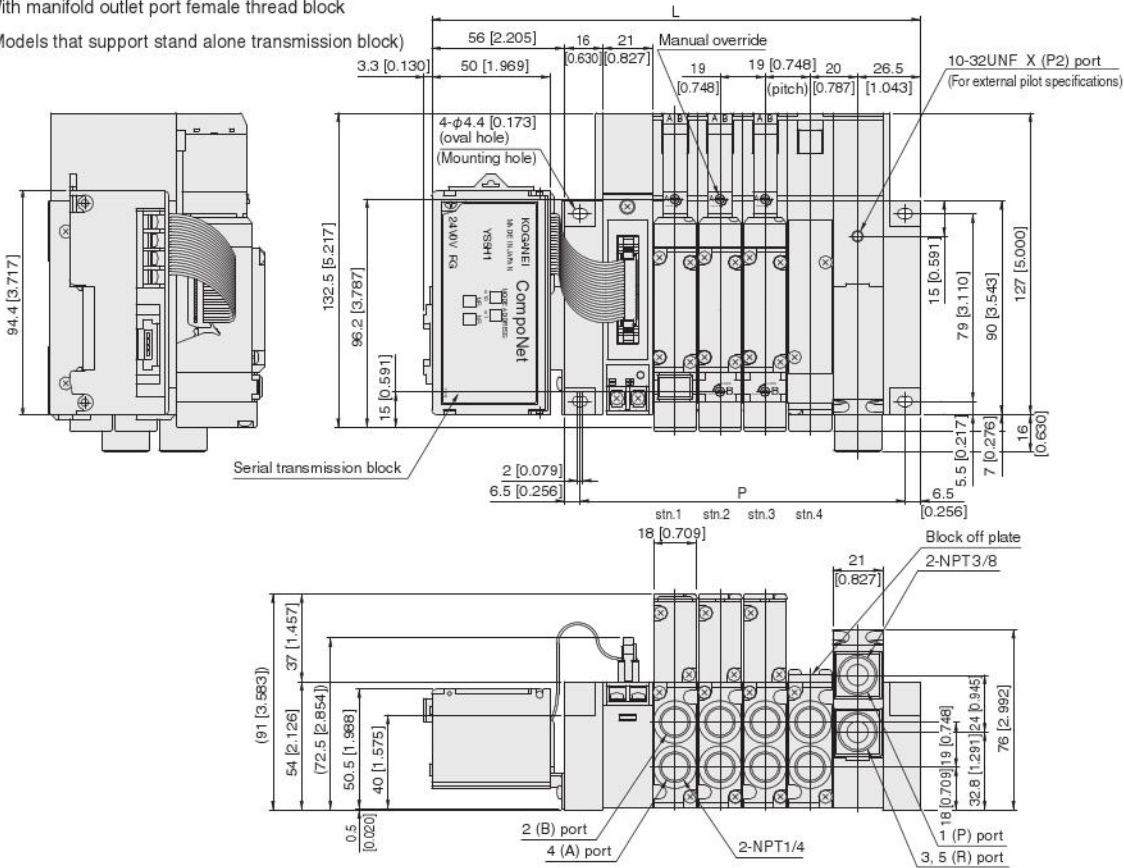

**Unit dimensions**

Number of units	L	P
2	168 [6.614]	99 [3.898]
3	187 [7.362]	118 [4.646]
4	206 [8.110]	137 [5.394]
5	225 [8.858]	156 [6.142]
6	244 [9.606]	175 [6.890]
7	263 [10.354]	194 [7.638]
8	282 [11.102]	213 [8.386]
9	301 [11.850]	232 [9.134]
10	320 [12.598]	251 [9.882]
11	339 [13.346]	270 [10.630]
12	358 [14.094]	289 [11.378]
13	377 [14.843]	308 [12.126]
14	396 [15.591]	327 [12.874]
15	415 [16.339]	346 [13.622]
16	434 [17.087]	365 [14.370]

Remark: Add 21 [0.827] to the L and P dimensions above when two of the piping blocks are used.

\* The communication connectors are sold by Omron Corporation. Contact Omron Corporation for details.

**F18M** [Number of valves] **SH** [Pilot specifications] (Direct piping type)

With valve outlet port female thread block

(Models that support stand alone transmission block)

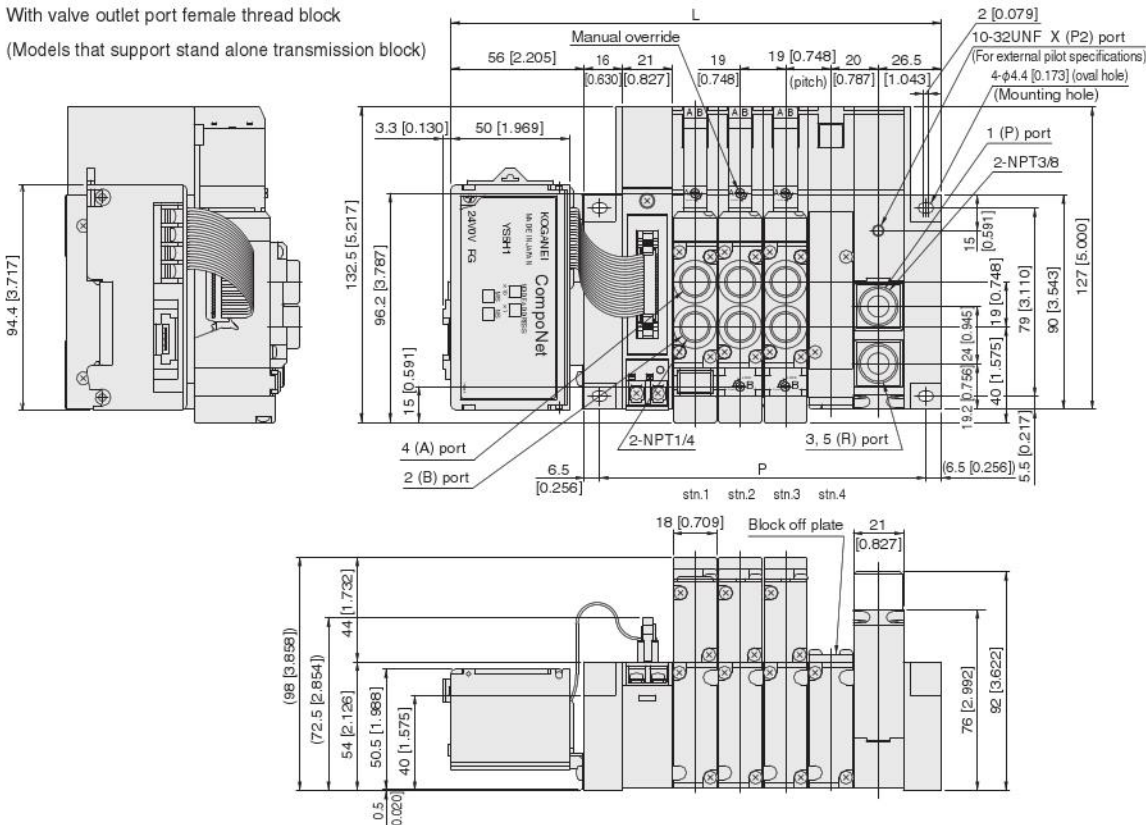

**Unit dimensions**

Number of units	L	P
2	168 [6.614]	99 [3.898]
3	187 [7.362]	118 [4.646]
4	206 [8.110]	137 [5.394]
5	225 [8.858]	156 [6.142]
6	244 [9.606]	175 [6.890]
7	263 [10.354]	194 [7.638]
8	282 [11.102]	213 [8.386]
9	301 [11.850]	232 [9.134]
10	320 [12.598]	251 [9.882]
11	339 [13.346]	270 [10.630]
12	358 [14.094]	289 [11.378]
13	377 [14.843]	308 [12.126]
14	396 [15.591]	327 [12.874]
15	415 [16.339]	346 [13.622]
16	434 [17.087]	365 [14.370]

Remark: Add 21 [0.827] to the L and P dimensions above when two of the piping blocks are used.

\* The communication connectors are sold by Omron Corporation. Contact Omron Corporation for details.



# F Series Specifications confirmation Form

## INDEX

---

### ■F10, F15 Series

Monoblock Manifold A Type (Base Piping Type)	202
Monoblock Manifold F Type (Direct Piping Type)	204
Monoblock Manifold A Type, Wire-Saving Type (Base Piping Type)	206
Monoblock Manifold F Type, Wire-Saving Type (Direct Piping Type)	208
PC Board Manifold A Type (Base Piping Type)	210
PC Board Manifold F Type (Direct Piping Type)	212
Split Manifold Non-Plug-in Type	214
Split Manifold Plug-in Type	216
Serial Transmission Compatible Manifold	218

### ■F18 Series

Monoblock Manifold A Type (Base Piping Type)	220
Monoblock Manifold F Type (Direct Piping Type)	221
Split Manifold Non-Plug-in Type	222
Split Manifold Plug-in Type	224
Serial Transmission Compatible Manifold	226

# Example of Specifications Confirmation Form

When ordering F series manifolds, use this specifications confirmation form for complex model configurations, for confirming specifications, etc.

Using the example below for reference, fill out the required items in the "Specifications confirmation Forms" found on p.202 and up, and send it. (Make copies of the Specifications Confirmation Form for your use.)

## F10, F15 Series

### Monoblock Manifold

### A Type (Base Piping Type)

## Specifications Confirmation Form 1/2

• Fill in selections inside the thick-lined boxes.

Manifold model

<b>F</b>	<b>10</b>	<b>M</b>	<b>8</b>	<b>A</b>	<b>J</b>	
		Valve units 2 to 20		AH		

**Pilot specification**  
Blank: Internal pilot manifold  
G : External pilot manifold

**Valve size**  
10: 10mm width  
15: 15mm width

**Manifold outlet specification**  
J : With dual use fitting blocks  
M : With female thread blocks  
L : With selectable fitting blocks

stn.	<input type="checkbox"/>	F	Valve size	T	Valve specification	<input type="checkbox"/>	- Note 3	- A1 -	- PS -	- Note 4	- Note 8	- Note 5	- DC24V
------	--------------------------	---	------------	---	---------------------	--------------------------	----------	--------	--------	----------	----------	----------	---------

Operation type

Blank: Internal pilot type<sup>Note1</sup>  
G : External pilot type (for positive pressure)<sup>Note2</sup>  
V : External pilot type (for vacuum)<sup>Note2</sup>

Manual override

Blank: Manual override button  
R : Manual override lever<sup>Note3</sup>  
83 : Protruding locking type<sup>Note11</sup>

Wiring specification

Blank: L type plug connector, Without connector  
PN : S type plug connector, Without connector  
PS : S type plug connector, Lead wire length 300mm [11.8in.]  
PL : L type plug connector, Lead wire length 300mm [11.8in.]  
PS3 : S type plug connector, Lead wire length 3000mm [118in.]  
PL3 : L type plug connector, Lead wire length 3000mm [118in.]  
CPS : Pre-wired positive common terminal S type plug connector, Lead wire length 300mm [11.8in.]  
CPL : Pre-wired positive common terminal L type plug connector, Lead wire length 300mm [11.8in.]  
CPS3 : Pre-wired positive common terminal S type plug connector, Lead wire length 3000mm [118in.]  
CPL3 : Pre-wired positive common terminal L type plug connector, Lead wire length 3000mm [118in.]  
39L : DIN connector type with indicator<sup>Note12</sup>  
39N : DIN connector type without indicator<sup>Note12</sup>

Manifold fitting specifications<sup>Note4</sup>

Can be selected only when the manifold type is A and the manifold outlet specification is L (with selectable fitting blocks (metric))

J5 : Manifold side outlet port with single use fitting block (F10: φ4, F15: φ6)  
J6 : Manifold side outlet port with single use fitting block (F10: φ6, F15: φ8)  
M : Manifold side outlet port with female thread block (F10: M5X0.8, F15: Rc1/8)  
J5A : Manifold side outlet port with single use fitting block, 3-port normally closed (NC) (F10: φ4, F15: φ6)  
J5B : Manifold side outlet port with single use fitting block, 3-port normally open (NO) (F10: φ4, F15: φ6)  
J6A : Manifold side outlet port with single use fitting block, 3-port normally closed (NC) (F10: φ6, F15: φ8)  
J6B : Manifold side outlet port with single use fitting block, 3-port normally open (NO) (F10: φ6, F15: φ8)  
MA : Manifold side outlet port with female thread block, 3-port normally closed (NC) (F10: M5X0.8, F15: Rc1/8)  
MB : Manifold side outlet port with female thread block, 3-port normally open (NO) (F10: M5X0.8, F15: Rc1/8)

Can be selected only when the manifold type is AH and the manifold outlet specification is L (with selectable fitting blocks (imperial))

MH : Manifold side outlet port with female thread block (F10: 10-32UNF, F15: NPT1/8)  
MAH : Manifold side outlet port with female thread block, 3-port normally closed (NC) (F10: 10-32UNF, F15: NPT1/8)  
MBH : Manifold side outlet port with female thread block, 3-port normally open (NO) (F10: 10-32UNF, F15: NPT1/8)

Voltage

DC12V<sup>Note9</sup>  
DC24V  
AC100V<sup>Note10,13</sup>  
AC120V<sup>Note10</sup>  
AC240V<sup>Note10,11</sup>

Back pressure prevention valve<sup>Note8</sup>

Blank: No back pressure prevention valve  
E1 : With back pressure prevention valve

Individual air supply and exhaust apacer, stop valve<sup>Note5</sup>

Blank: No spacer and no stop valve  
NPM : Individual air supply spacer (with M5 female thread for F10)<sup>Note13</sup>  
NP6 : Individual air supply spacer (with φ6 fitting for F15)<sup>Note13</sup>  
NP8 : Individual air supply spacer (with φ8 fitting for F15)<sup>Note13</sup>  
NRM : Individual exhaust spacer (with M5 female thread for F10)<sup>Note13</sup>  
NR6 : Individual exhaust spacer (with φ6 fitting for F15)<sup>Note13</sup>  
NR8 : Individual exhaust spacer (with φ8 fitting for F15)<sup>Note13</sup>  
STP : With stop valve<sup>Note1</sup>

Enter ○ in each designated station in tables on the next page.

202 KOGANEI

# F10, F15 Series

Monoblock Manifold A Type (Base Piping Type)

## Specifications Confirmation Form 2/2

※For specifying the valve and block-off plate to be mounted at each station, enter ○ in each applicable box below.

Mounting valve, block-off plate		Station	1	2	3	4	5	6	7	8	9	10	11	12	13	14	15	16	17	18	19	20	
F	<input type="checkbox"/> T0	2-position, for single solenoid only	<input type="checkbox"/>	<input type="checkbox"/>																			
F	<input type="checkbox"/> T1	2-position, single solenoid specification			<input type="checkbox"/>	<input type="checkbox"/>																	
F	<input type="checkbox"/> T2	2-position, double solenoid specification					<input type="checkbox"/>	<input type="checkbox"/>															
F	<input type="checkbox"/> T3	3-position, closed center							<input type="checkbox"/>														
F	<input type="checkbox"/> T4 <sup>Note5</sup>	3-position, exhaust center								<input type="checkbox"/>													
F	<input type="checkbox"/> T5 <sup>Note5</sup>	3-position, pressure center									<input type="checkbox"/>												
F	<input type="checkbox"/> TA <sup>Note7</sup>	Tandem 3-port (NC and NC)																					
F	<input type="checkbox"/> TB <sup>Note7</sup>	Tandem 3-port (NO and NO)																					
F	<input type="checkbox"/> TC <sup>Note7</sup>	Tandem 3-port (NC and NO)																					
F	<input type="checkbox"/> LT0	(Low current type) 2-position, for single solenoid only																					
F	<input type="checkbox"/> LT1	(Low current type) 2-position, single solenoid specification																					
F	<input type="checkbox"/> LT2	(Low current type) 2-position, double solenoid specification																					
F	<input type="checkbox"/> LT3	(Low current type) 3-position, closed center																					
F	<input type="checkbox"/> LT4 <sup>Note5</sup>	(Low current type) 3-position, exhaust center																					
F	<input type="checkbox"/> LT5 <sup>Note5</sup>	(Low current type) 3-position, pressure center																					
F	<input type="checkbox"/> LTA <sup>Note7</sup>	(Low current type) Tandem 3-port (NC and NC)																					
F	<input type="checkbox"/> LTB <sup>Note7</sup>	(Low current type) Tandem 3-port (NO and NO)																					
F	<input type="checkbox"/> LTC <sup>Note7</sup>	(Low current type) Tandem 3-port (NC and NO)																					
F	<input type="checkbox"/> BP	Block-off plate																					
Manual override	R	Manual override lever <sup>Note3</sup>	<input type="checkbox"/>	<input type="checkbox"/>																			
	83	Protruding locking type <sup>Note11</sup>																					
Manifold fitting specification <sup>Note4</sup> (Manifold side outlet port)	J5	With single use fitting block																					
	J6	With single use fitting block																					
	M	With female thread block																					
	J5A	With single use fitting block, 3-port normally closed (NC)																					
	J5B	With single use fitting block, 3-port normally open (NO)																					
	J6A	With single use fitting block, 3-port normally closed (NC)																					
	J6B	With single use fitting block, 3-port normally open (NO)																					
	MA	With female thread block, 3-port normally closed (NC)																					
	MB	With female thread block, 3-port normally open (NO)																					
	MH	With female thread block																					
MAH	With female thread block, 3-port normally closed (NC)																						
MBH	With female thread block, 3-port normally open (NO)																						
E1 <sup>Note8</sup>	Back pressure prevention valve																						
NPM	Individual air supply spacer (with M5 female thread for F10)			<input type="checkbox"/>	<input type="checkbox"/>																		
NP6	Individual air supply spacer (with φ 6 fitting for F15)																						
NP8	Individual air supply spacer (with φ 8 fitting for F15)																						
NRM	Individual exhaust spacer (with M5 female thread for F10)																						
NR6	Individual exhaust spacer (with φ 6 fitting for F15)																						
NR8	Individual exhaust spacer (with φ 8 fitting for F15)																						
STP	With stop valve																						

- Notes: 1. Cannot be mounted on the external pilot manifold.  
 2. Cannot be mounted on the internal pilot manifold.  
 3. To designate a manual override lever, enter ○ in the manual override boxes of the designated station in the above table.  
 When the valve specification is T1 or T2, the manual override lever is placed only on the A side. This is not available with -39□.  
 4. When the manifold outlet specifications are L (with selectable fitting), select fitting specification for each station, and enter ○ in the manifold fitting specification boxes of the above table.  
 The 3-port specifications are only available in valve specification T0, T1, and T2.  
 5. When mounting the individual air supply or exhaust spacer or stop valve, enter ○ in the spacer or stop valve boxes of the designated stations in the above table.  
 6. Not available in the vacuum valves.  
 7. Not available in external pilot type and vacuum valves.  
 8. When mounting the back pressure prevention valve, enter ○ in the spacer boxes of the designated stations in the above table. Not available with the individual exhaust spacer and vacuum valve.  
 9. Not available in low-current type.  
 10. Not available in low-current type and tandem 3-port valves.  
 11. Only for wiring specification -39□.  
 12. Only for F15 series and not available for valve specification T1, TA, TB, and TC. In addition, the valve is used only as a double solenoid for T2.  
 13. Not available with DIN connectors (-39□).

Quantity 5 set Delivery June 1

KOGANEI 203

CONFIRMATION FORM

CONFIRMATION FORM

# F10, F15 Series

Monoblock Manifold  
A Type (Base Piping Type)

Company name	
Contact person	
Order No.	

## Specifications Confirmation Form 1/2

• Fill in selections inside the thick-lined boxes.

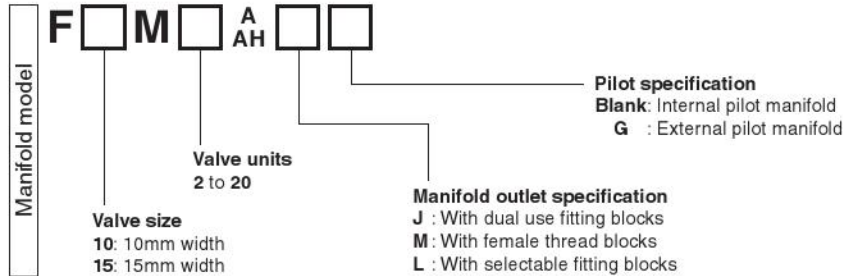

stn.  **F**  Valve size  **T**  Valve specification  -  Note 3 - **A1** -  -  Note 4 -  Note 8 -  Note 5 -

**Operation type**  
Blank: Internal pilot type<sup>Note1</sup>  
G : External pilot type (for positive pressure)<sup>Note2</sup>  
V : External pilot type (for vacuum)<sup>Note2</sup>

**Manual override**  
Blank: Manual override button  
R : Manual override lever<sup>Note3</sup>  
83 : Protruding locking type<sup>Note11</sup>

**Wiring specification**  
Blank: L type plug connector, Without connector  
PN : S type plug connector, Without connector  
PS : S type plug connector, Lead wire length 300mm [11.8in.]  
PL : L type plug connector, Lead wire length 300mm [11.8in.]  
PS3 : S type plug connector, Lead wire length 3000mm [118in.]  
PL3 : L type plug connector, Lead wire length 3000mm [118in.]  
CPS : Pre-wired positive common terminal S type plug connector, Lead wire length 300mm [11.8in.]  
CPL : Pre-wired positive common terminal L type plug connector, Lead wire length 300mm [11.8in.]  
CPS3 : Pre-wired positive common terminal S type plug connector, Lead wire length 3000mm [118in.]  
CPL3 : Pre-wired positive common terminal L type plug connector, Lead wire length 3000mm [118in.]  
39L : DIN connector type with indicator<sup>Note12</sup>  
39N : DIN connector type without indicator<sup>Note12</sup>

**Manifold fitting specifications**<sup>Note4</sup>  
Can be selected only when the manifold type is **A** and the manifold outlet specification is **L** (with selectable fitting blocks (metric))  
J5 : Manifold side outlet port with single use fitting block (F10: φ4, F15: φ6)  
J6 : Manifold side outlet port with single use fitting block (F10: φ6, F15: φ8)  
M : Manifold side outlet port with female thread block (F10: M5X0.8, F15: Rc1/8)  
J5A : Manifold side outlet port with single use fitting block, 3-port normally closed (NC) (F10: φ4, F15: φ6)  
J5B : Manifold side outlet port with single use fitting block, 3-port normally open (NO) (F10: φ4, F15: φ6)  
J6A : Manifold side outlet port with single use fitting block, 3-port normally closed (NC) (F10: φ6, F15: φ8)  
J6B : Manifold side outlet port with single use fitting block, 3-port normally open (NO) (F10: φ6, F15: φ8)  
MA : Manifold side outlet port with female thread block, 3-port normally closed (NC) (F10: M5X0.8, F15: Rc1/8)  
MB : Manifold side outlet port with female thread block, 3-port normally open (NO) (F10: M5X0.8, F15: Rc1/8)

Can be selected only when the manifold type is **AH** and the manifold outlet specification is **L** (with selectable fitting blocks (imperial))  
MH : Manifold side outlet port with female thread block (F10:10-32UNF, F15: NPT1/8)  
MAH : Manifold side outlet port with female thread block, 3-port normally closed (NC) (F10:10-32UNF, F15: NPT1/8)  
MBH : Manifold side outlet port with female thread block, 3-port normally open (NO) (F10:10-32UNF, F15: NPT1/8)

**Back pressure prevention valve**<sup>Note8</sup>  
Blank: No back pressure prevention valve  
E1 : With back pressure prevention valve

**Individual air supply and exhaust apacer, stop valve**<sup>Note5</sup>  
Blank: No spacer and no stop valve  
NPM : Individual air supply spacer (with M5 female thread for F10)<sup>Note13</sup>  
NP6 : Individual air supply spacer (with φ6 fitting for F15)<sup>Note13</sup>  
NP8 : Individual air supply spacer (with φ8 fitting for F15)<sup>Note13</sup>  
NRM : Individual exhaust spacer (with M5 female thread for F10)<sup>Note13</sup>  
NR6 : Individual exhaust spacer (with φ6 fitting for F15)<sup>Note13</sup>  
NR8 : Individual exhaust spacer (with φ8 fitting for F15)<sup>Note13</sup>  
STP : With stop valve<sup>Note1</sup>

**Voltage**  
DC12V<sup>Note9</sup>  
DC24V  
AC100V<sup>Note10,13</sup>  
AC120V<sup>Note10</sup>  
AC240V<sup>Note10,11</sup>

Enter ○ in each designated station in tables on the next page.

# F10, F15 Series

## Monoblock Manifold A Type (Base Piping Type)

# Specifications Confirmation Form 2/2

※For specifying the valve and block-off plate to be mounted at each station, enter ○ in each applicable box below.

Mounting valve models	Mounting valve, block-off plate	Station	1	2	3	4	5	6	7	8	9	10	11	12	13	14	15	16	17	18	19	20		
		<input type="checkbox"/> <b>T0</b> 2-position, for single solenoid only																						
	<input type="checkbox"/> <b>T1</b> 2-position, single solenoid specification																							
	<input type="checkbox"/> <b>T2</b> 2-position, double solenoid specification																							
	<input type="checkbox"/> <b>T3</b> 3-position, closed center																							
	<input type="checkbox"/> <b>T4</b> <sup>Note6</sup> 3-position, exhaust center																							
	<input type="checkbox"/> <b>T5</b> <sup>Note6</sup> 3-position, pressure center																							
	<input type="checkbox"/> <b>TA</b> <sup>Note7</sup> Tandem 3-port (NC and NC)																							
	<input type="checkbox"/> <b>TB</b> <sup>Note7</sup> Tandem 3-port (NO and NO)																							
	<input type="checkbox"/> <b>TC</b> <sup>Note7</sup> Tandem 3-port (NC and NO)																							
	<input type="checkbox"/> <b>LT0</b> (Low current type) 2-position, for single solenoid only																							
	<input type="checkbox"/> <b>LT1</b> (Low current type) 2-position, single solenoid specification																							
	<input type="checkbox"/> <b>LT2</b> (Low current type) 2-position, double solenoid specification																							
	<input type="checkbox"/> <b>LT3</b> (Low current type) 3-position, closed center																							
	<input type="checkbox"/> <b>LT4</b> <sup>Note6</sup> (Low current type) 3-position, exhaust center																							
	<input type="checkbox"/> <b>LT5</b> <sup>Note6</sup> (Low current type) 3-position, pressure center																							
	<input type="checkbox"/> <b>LTA</b> <sup>Note7</sup> (Low current type) Tandem 3-port (NC and NC)																							
	<input type="checkbox"/> <b>LTB</b> <sup>Note7</sup> (Low current type) Tandem 3-port (NO and NO)																							
	<input type="checkbox"/> <b>LTC</b> <sup>Note7</sup> (Low current type) Tandem 3-port (NC and NO)																							
	<input type="checkbox"/> <b>BP</b> Block-off plate																							
Manual override	<input type="checkbox"/> <b>R</b> Manual override lever <sup>Note3</sup>																							
	<input type="checkbox"/> <b>83</b> Protruding locking type <sup>Note11</sup>																							
Manifold fitting specification <sup>Note4</sup> (Manifold side outlet port)	<input type="checkbox"/> <b>J5</b> With single use fitting block																							
	<input type="checkbox"/> <b>J6</b> With single use fitting block																							
	<input type="checkbox"/> <b>M</b> With female thread block																							
	<input type="checkbox"/> <b>J5A</b> With single use fitting block, 3-port normally closed (NC)																							
	<input type="checkbox"/> <b>J5B</b> With single use fitting block, 3-port normally open (NO)																							
	<input type="checkbox"/> <b>J6A</b> With single use fitting block, 3-port normally closed (NC)																							
	<input type="checkbox"/> <b>J6B</b> With single use fitting block, 3-port normally open (NO)																							
	<input type="checkbox"/> <b>MA</b> With female thread block, 3-port normally closed (NC)																							
	<input type="checkbox"/> <b>MB</b> With female thread block, 3-port normally open (NO)																							
	<input type="checkbox"/> <b>MH</b> With female thread block																							
	<input type="checkbox"/> <b>MAH</b> With female thread block, 3-port normally closed (NC)																							
<input type="checkbox"/> <b>MBH</b> With female thread block, 3-port normally open (NO)																								
<input type="checkbox"/> <b>E1</b> <sup>Note8</sup> Back pressure prevention valve																								
<input type="checkbox"/> <b>NPM</b> Individual air supply spacer (with M5 female thread for F10)																								
<input type="checkbox"/> <b>NP6</b> Individual air supply spacer (with φ 6 fitting for F15)																								
<input type="checkbox"/> <b>NP8</b> Individual air supply spacer (with φ 8 fitting for F15)																								
<input type="checkbox"/> <b>NRM</b> Individual exhaust spacer (with M5 female thread for F10)																								
<input type="checkbox"/> <b>NR6</b> Individual exhaust spacer (with φ 6 fitting for F15)																								
<input type="checkbox"/> <b>NR8</b> Individual exhaust spacer (with φ 8 fitting for F15)																								
<input type="checkbox"/> <b>STP</b> With stop valve																								

- Notes: 1. Cannot be mounted on the external pilot manifold.  
 2. Cannot be mounted on the internal pilot manifold.  
 3. To designate a manual override lever, enter ○ in the manual override boxes of the designated station in the above table.  
 When the valve specification is **T1** or **T2**, the manual override lever is placed only on the A side. This is not available with **-39□**.  
 4. When the manifold outlet specifications are **L** (with selectable fitting), select fitting specification for each station, and enter ○ in the manifold fitting specification boxes of the above table.  
 The 3-port specifications are only available in valve specification **T0**, **T1**, and **T2**.  
 5. When mounting the individual air supply or exhaust spacer or stop valve, enter ○ in the spacer or stop valve boxes of the designated stations in the above table.  
 6. Not available in the vacuum valves.  
 7. Not available in external pilot type and vacuum valves.  
 8. When mounting the back pressure prevention valve, enter ○ in the back pressure prevention valve boxes of the designated stations in the above table.  
 Not available with the individual exhaust spacer and vacuum valve.  
 9. Not available in low-current type.  
 10. Not available in low-current type and tandem 3-port valves.  
 11. Only for wiring specification **-39□**.  
 12. Only for **F15** series and not available for valve specification **T1**, **TA**, **TB**, and **TC**. In addition, the valve is used only as a double solenoid for **T2**.  
 13. Not available with DIN connectors (**-39□**).

Quantity	set	Delivery
----------	-----	----------

# F10, F15 Series

Monoblock Manifold  
F Type (Direct Piping Type)

Company name	
Contact person	
Order No.	

## Specifications Confirmation Form 1/2

• Fill in selections inside the thick-lined boxes.

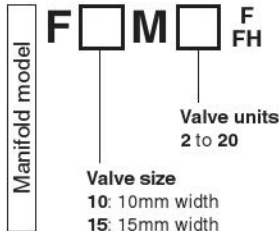

Mounting valve model	stn. <input type="checkbox"/> F <input type="checkbox"/> Valve size <input type="checkbox"/> T <input type="checkbox"/> Valve specification <input type="checkbox"/> Note 1 - <input type="checkbox"/> Note 2 - <input type="checkbox"/> Note 4 - <input type="checkbox"/> Note 3 <input type="checkbox"/>	Voltage DC12V <sup>Note5</sup> DC24V AC100V <sup>Note6,9</sup> AC120V <sup>Note6</sup> AC240V <sup>Note6</sup>
	<p><b>Manual override</b> _____</p> <p><b>Blank:</b> Manual override button  <b>R</b> : Manual override lever<sup>Note1</sup>  <b>83</b> : Protruding locking type<sup>Note7</sup></p> <p><b>Valve outlet type</b><sup>Note2</sup> _____</p> <p>Can be selected only when the manifold type is <b>F</b> (metric).</p> <p><b>FJ</b> : With dual use fitting block (<b>F10</b>: φ 4 and φ 6, <b>F15</b>: φ 6 and φ 8)  <b>FJ5</b> : With single use fitting block (<b>F10</b>: φ 4, <b>F15</b>: φ 6)  <b>FJ6</b> : With single use fitting block (<b>F10</b>: φ 6, <b>F15</b>: φ 8)  <b>FM</b> : With female thread block (<b>F10</b>: M5X0.8, <b>F15</b>: Rc1/8)  <b>FJ5A</b> : With single use fitting block, 3-port normally closed (NC) (<b>F10</b>: φ 4, <b>F15</b>: φ 6)  <b>FJ5B</b> : With single use fitting block, 3-port normally open (NO) (<b>F10</b>: φ 4, <b>F15</b>: φ 6)  <b>FJ6A</b> : With single use fitting block, 3-port normally closed (NC) (<b>F10</b>: φ 6, <b>F15</b>: φ 8)  <b>FJ6B</b> : With single use fitting block, 3-port normally open (NO) (<b>F10</b>: φ 6, <b>F15</b>: φ 8)  <b>FMA</b> : With female thread block, 3-port normally closed (NC) (<b>F10</b>: M5X0.8, <b>F15</b>: Rc1/8)  <b>FMB</b> : With female thread block, 3-port normally open (NO) (<b>F10</b>: M5X0.8, <b>F15</b>: Rc1/8)</p> <p>Can be selected only when the manifold type is <b>FH</b> (imperial).</p> <p><b>FMH</b> : With female thread block (<b>F10</b>: 10-32UNF, <b>F15</b>: NPT1/8)  <b>FMAH</b> : With female thread block, 3-port normally closed (NC) (<b>F10</b>: 10-32UNF, <b>F15</b>: NPT1/8)  <b>FMBH</b> : With female thread block, 3-port normally open (NO) (<b>F10</b>: 10-32UNF, <b>F15</b>: NPT1/8)</p>	<p><b>Individual air supply and exhaust spacer, stop valve</b><sup>Note3</sup></p> <p><b>Blank:</b> No spacer and no stop valve  <b>NPM</b> : Individual air supply spacer (with M5 female thread for F10)<sup>Note9</sup>  <b>NP6</b> : Individual air supply spacer (with φ 6 fitting for F15)<sup>Note9</sup>  <b>NP8</b> : Individual air supply spacer (with φ 8 fitting for F15)<sup>Note9</sup>  <b>NRM</b> : Individual exhaust spacer (with M5 female thread for F10)<sup>Note9</sup>  <b>NR6</b> : Individual exhaust spacer (with φ 6 fitting for F15)<sup>Note9</sup>  <b>NR8</b> : Individual exhaust spacer (with φ 8 fitting for F15)<sup>Note9</sup>  <b>STP</b> : With stop valve</p> <p><b>Back pressure prevention valve</b><sup>Note4</sup></p> <p><b>Blank:</b> No back pressure prevention valve  <b>E1</b> : With back pressure prevention valve</p>
	<p><b>Wiring specification</b></p> <p><b>Blank:</b> L type plug connector, Without connector  <b>PN</b> : S type plug connector, Without connector  <b>PS</b> : S type plug connector, Lead wire length 300mm [11.8in.]  <b>PL</b> : L type plug connector, Lead wire length 300mm [11.8in.]  <b>PS3</b> : S type plug connector, Lead wire length 3000mm [118in.]  <b>PL3</b> : L type plug connector, Lead wire length 3000mm [118in.]  <b>CPS</b> : Pre-wired positive common terminal S type plug connector, Lead wire length 300mm [11.8in.]  <b>CPL</b> : Pre-wired positive common terminal L type plug connector, Lead wire length 300mm [11.8in.]  <b>CPS3</b> : Pre-wired positive common terminal S type plug connector, Lead wire length 3000mm [118in.]  <b>CPL3</b> : Pre-wired positive common terminal L type plug connector, Lead wire length 3000mm [118in.]  <b>39L</b> : DIN connector type with indicator<sup>Note8</sup>  <b>39N</b> : DIN connector type without indicator<sup>Note8</sup></p>	
	<p>Enter ○ in each designated station in tables on the next page.</p>	

# F10, F15 Series

## Monoblock Manifold F Type (Direct Piping Type)

# Specifications Confirmation Form 2/2

※For specifying the valve and block-off plate to be mounted at each station, enter ○ in each applicable box below.

Mounting valve, block-off plate		Station	1	2	3	4	5	6	7	8	9	10	11	12	13	14	15	16	17	18	19	20
Mounting valve models	<input type="checkbox"/> <b>T0</b>	2-position, for single solenoid only																				
	<input type="checkbox"/> <b>T1</b>	2-position, single solenoid specification																				
	<input type="checkbox"/> <b>T2</b>	2-position, double solenoid specification																				
	<input type="checkbox"/> <b>T3</b>	3-position, closed center																				
	<input type="checkbox"/> <b>T4</b>	3-position, exhaust center																				
	<input type="checkbox"/> <b>T5</b>	3-position, pressure center																				
	<input type="checkbox"/> <b>TA</b>	Tandem 3-port (NC and NC)																				
	<input type="checkbox"/> <b>TB</b>	Tandem 3-port (NO and NO)																				
	<input type="checkbox"/> <b>TC</b>	Tandem 3-port (NC and NO)																				
	<input type="checkbox"/> <b>LT0</b>	(Low current type) 2-position, for single solenoid only																				
	<input type="checkbox"/> <b>LT1</b>	(Low current type) 2-position, single solenoid specification																				
	<input type="checkbox"/> <b>LT2</b>	(Low current type) 2-position, double solenoid specification																				
	<input type="checkbox"/> <b>LT3</b>	(Low current type) 3-position, closed center																				
	<input type="checkbox"/> <b>LT4</b>	(Low current type) 3-position, exhaust center																				
	<input type="checkbox"/> <b>LT5</b>	(Low current type) 3-position, pressure center																				
	<input type="checkbox"/> <b>LTA</b>	(Low current type) Tandem 3-port (NC and NC)																				
	<input type="checkbox"/> <b>LTB</b>	(Low current type) Tandem 3-port (NO and NO)																				
	<input type="checkbox"/> <b>LTC</b>	(Low current type) Tandem 3-port (NC and NO)																				
	<input type="checkbox"/> <b>BP</b>	Block-off plate																				
	Manual override	<b>R</b>	Manual override lever <sup>Note1</sup>																			
<b>83</b>		Protruding locking type <sup>Note7</sup>																				
Valve outlet type <sup>Note2</sup>	<b>FJ</b>	With dual use fitting block																				
	<b>FJ5</b>	With single use fitting block																				
	<b>FJ6</b>	With single use fitting block																				
	<b>FM</b>	With female thread block																				
	<b>FJ5A</b>	With single use fitting block, 3-port normally closed (NC)																				
	<b>FJ5B</b>	With single use fitting block, 3-port normally open (NO)																				
	<b>FJ6A</b>	With single use fitting block, 3-port normally closed (NC)																				
	<b>FJ6B</b>	With single use fitting block, 3-port normally open (NO)																				
	<b>FMA</b>	With female thread block, 3-port normally closed (NC)																				
	<b>FMB</b>	With female thread block, 3-port normally open (NO)																				
	<b>FMH</b>	With female thread block																				
<b>FMAH</b>	With female thread block, 3-port normally closed (NC)																					
<b>FMBH</b>	With female thread block, 3-port normally open (NO)																					
<b>E1</b> <sup>Note4</sup>	Back pressure prevention valve																					
<b>NPM</b>	Individual air supply spacer (with M5 female thread for F10)																					
<b>NP6</b>	Individual air supply spacer (with φ 6 fitting for F15)																					
<b>NP8</b>	Individual air supply spacer (with φ 8 fitting for F15)																					
<b>NRM</b>	Individual exhaust spacer (with M5 female thread for F10)																					
<b>NR6</b>	Individual exhaust spacer (with φ 6 fitting for F15)																					
<b>NR8</b>	Individual exhaust spacer (with φ 8 fitting for F15)																					
<b>STP</b>	With stop valve																					

- Notes: 1. To designate a manual override lever, enter ○ in the manual override boxes of the designated station in the above table.  
 When the valve specification is **T1** or **T2**, the manual override lever is placed only on the A side. This is not available with **-39□**.  
 2. Select valve outlet type for each station, and enter ○ in the valve outlet type boxes of the above table. The 3-port specifications are only available in valve specifications **T0**, **T1**, and **T2**.  
 3. When mounting the individual air supply or exhaust spacer or stop valve, enter ○ in the spacer or stop valve boxes of the designated stations in the above table.  
 4. When mounting the back pressure prevention valve, enter ○ in the back pressure prevention valve boxes of the designated stations in the above table.  
 Not available with the individual exhaust spacer.  
 5. Not available in low-current type.  
 6. Not available in low-current type and tandem 3-port valves.  
 7. Only for wiring specification **-39□**.  
 8. Only for **F15** series and not available for valve specification **T1**, **TA**, **TB**, and **TC**. In addition, the valve is used only as a double solenoid for **T2**.  
 9. Not available with DIN connectors (**-39□**).

Quantity	set	Delivery
----------	-----	----------

# F10, F15 Series

Monoblock Manifold A Type,  
Wire-Saving Type (Base Piping Type)

Company name	
Contact person	
Order No.	

## Specifications Confirmation Form 1/2

• Fill in selections inside the thick-lined boxes.

**Manifold model**

F  M  A  AH   -  -

**Valve size**  
10: 10mm width  
15: 15mm width

**Pilot specification**  
Blank: Internal pilot manifold  
G : External pilot manifold

**Manifold outlet specification**  
J : With dual use fitting blocks  
M : With female thread blocks  
L : With selectable fitting blocks

**Valve units**  
2 to  Note

**Wiring connection specification**  
Blank: Packed wiring  
W : Double wiring

**Wiring specification**  
F100N: Flat cable connector 10-pin  
F101N: Flat cable connector 10-pin  
F200N: Flat cable connector 20-pin  
F201N: Flat cable connector 20-pin  
F260N: Flat cable connector 26-pin  
(M2.6 mounting screw)  
D250N: D-sub connector 25-pin Note11  
D251N: D-sub connector 25-pin Note11  
(4-40UNC mounting screw)  
D250NU: D-sub connector 25-pin Note12  
D251NU: D-sub connector 25-pin Note12

Note: For the maximum number of units, check the table for maximum number of valve units by wiring specification on page 51.

**Mounting valve model**

stn.  F  Valve size  T  Valve specification  -  Note3 - A1 - PN -  Note4 -  Note8 -  Note5

**Operation type**  
Blank: Internal pilot type Note1  
G : External pilot type (for positive pressure) Note2  
V : External pilot type (for vacuum) Note2

**Manual override**  
Blank: Manual override button  
R : Manual override lever Note3

**Manifold fitting specifications** Note4  
Can be selected only when the manifold type is A and the manifold outlet specification is L (with selectable fitting block (metric)).  
J5: Manifold side outlet port with single use fitting block (F10: φ4, F15: φ6)  
J6: Manifold side outlet port with single use fitting block (F10: φ6, F15: φ8)  
M: Manifold side outlet port with female thread block (F10: M5X0.8, F15: Rc1/8)  
J5A: Manifold side outlet port with single use fitting block, 3-port normally closed (NC) (F10: φ4, F15: φ6)  
J5B: Manifold side outlet port with single use fitting block, 3-port normally open (NO) (F10: φ4, F15: φ6)  
J6A: Manifold side outlet port with single use fitting block, 3-port normally closed (NC) (F10: φ6, F15: φ8)  
J6B: Manifold side outlet port with single use fitting block, 3-port normally open (NO) (F10: φ6, F15: φ8)  
MA: Manifold side outlet port with female thread block, 3-port normally closed (NC) (F10: M5X0.8, F15: Rc1/8)  
MB: Manifold side outlet port with female thread block, 3-port normally open (NO) (F10: M5X0.8, F15: Rc1/8)  
Can be selected only when the manifold type is AH and the manifold outlet specification is L (with selectable fitting blocks (imperial)).  
MH: Manifold side outlet port with female thread block (F10: 10-32UNF, F15: NPT1/8)  
MAH: Manifold side outlet port with female thread block, 3-port normally closed (NC) (F10: 10-32UNF, F15: NPT1/8)  
MBH: Manifold side outlet port with female thread block, 3-port normally open (NO) (F10: 10-32UNF, F15: NPT1/8)

**Voltage**  
DC12V Note9  
DC24V  
AC100V Note10  
AC120V Note10

**Individual air supply and exhaust apacer, stop valve** Note5  
Blank: No spacer and no stop valve  
NPM: Individual air supply spacer (with M5 female thread for F10)  
NP6: Individual air supply spacer (with φ6 fitting for F15)  
NP8: Individual air supply spacer (with φ8 fitting for F15)  
NRM: Individual exhaust spacer (with M5 female thread for F10)  
NR6: Individual exhaust spacer (with φ6 fitting for F15)  
NR8: Individual exhaust spacer (with φ8 fitting for F15)  
STP: With stop valve Note1

**Back pressure prevention valve** Note8  
Blank: No back pressure prevention valve  
E1: With back pressure prevention valve

Enter ○ in each designated station in tables on the next page.

# F10, F15 Series

## Monoblock Manifold A Type, Wire-Saving Type (Base Piping Type)

# Specifications Confirmation Form 2/2

※For specifying the valve and block-off plate to be mounted at each station, enter ○ in each applicable box below.

Mounting valve models	Mounting valve, block-off plate	Station	1	2	3	4	5	6	7	8	9	10	11	12	13	14	15	16	17	18	19	20	
		<input type="checkbox"/> <b>T0</b> 2-position, for single solenoid only																					
	<input type="checkbox"/> <b>T1</b> 2-position, single solenoid specification																						
	<input type="checkbox"/> <b>T2</b> 2-position, double solenoid specification																						
	<input type="checkbox"/> <b>T3</b> 3-position, closed center																						
	<input type="checkbox"/> <b>T4</b> <sup>Note6</sup> 3-position, exhaust center																						
	<input type="checkbox"/> <b>T5</b> <sup>Note6</sup> 3-position, pressure center																						
	<input type="checkbox"/> <b>TA</b> <sup>Note7</sup> Tandem 3-port (NC and NC)																						
	<input type="checkbox"/> <b>TB</b> <sup>Note7</sup> Tandem 3-port (NO and NO)																						
	<input type="checkbox"/> <b>TC</b> <sup>Note7</sup> Tandem 3-port (NC and NO)																						
	<input type="checkbox"/> <b>LT0</b> (Low current type) 2-position, for single solenoid only																						
	<input type="checkbox"/> <b>LT1</b> (Low current type) 2-position, single solenoid specification																						
	<input type="checkbox"/> <b>LT2</b> (Low current type) 2-position, double solenoid specification																						
	<input type="checkbox"/> <b>LT3</b> (Low current type) 3-position, closed center																						
	<input type="checkbox"/> <b>LT4</b> <sup>Note6</sup> (Low current type) 3-position, exhaust center																						
	<input type="checkbox"/> <b>LT5</b> <sup>Note6</sup> (Low current type) 3-position, pressure center																						
	<input type="checkbox"/> <b>LTA</b> <sup>Note7</sup> (Low current type) Tandem 3-port (NC and NC)																						
	<input type="checkbox"/> <b>LTB</b> <sup>Note7</sup> (Low current type) Tandem 3-port (NO and NO)																						
	<input type="checkbox"/> <b>LTC</b> <sup>Note7</sup> (Low current type) Tandem 3-port (NC and NO)																						
	<input type="checkbox"/> <b>BP</b> Block-off plate																						
	Manual override (-R) Manual override lever <sup>Note3</sup>																						
Manifold fitting specification <sup>Note4</sup> (Manifold side outlet port)	<b>J5</b> With single use fitting block																						
	<b>J6</b> With single use fitting block																						
	<b>M</b> With female thread block																						
	<b>J5A</b> With single use fitting block, 3-port normally closed (NC)																						
	<b>J5B</b> With single use fitting block, 3-port normally open (NO)																						
	<b>J6A</b> With single use fitting block, 3-port normally closed (NC)																						
	<b>J6B</b> With single use fitting block, 3-port normally open (NO)																						
	<b>MA</b> With female thread block, 3-port normally closed (NC)																						
	<b>MB</b> With female thread block, 3-port normally open (NO)																						
	<b>MH</b> With female thread block																						
<b>MAH</b> With female thread block, 3-port normally closed (NC)																							
<b>MBH</b> With female thread block, 3-port normally open (NO)																							
<b>E1</b> <sup>Note8</sup> Back pressure prevention valve																							
<b>NPM</b> Individual air supply spacer (with M5 female thread for F10)																							
<b>NP6</b> Individual air supply spacer (with φ 6 fitting for F15)																							
<b>NP8</b> Individual air supply spacer (with φ 8 fitting for F15)																							
<b>NRM</b> Individual exhaust spacer (with M5 female thread for F10)																							
<b>NR6</b> Individual exhaust spacer (with φ 6 fitting for F15)																							
<b>NR8</b> Individual exhaust spacer (with φ 8 fitting for F15)																							
<b>STP</b> With stop valve																							

- Notes: 1. Cannot be mounted on the external pilot manifold.  
 2. Cannot be mounted on the internal pilot manifold.  
 3. To designate a manual override lever, enter ○ in the manual override boxes of the designated station in the above table.  
 When the valve specification is **T1** or **T2**, the manual override lever is placed only on the A side.  
 4. When the manifold outlet specifications are **L** (with selectable fitting), select fitting specification for each station, and enter ○ in the manifold fitting specification boxes of the above table.  
 The 3-port specifications are only available in valve specification **T0**, **T1**, and **T2**.  
 5. When mounting the individual air supply or exhaust spacer or stop valve, enter ○ in the spacer or stop valve boxes of the designated stations in the above table.  
 6. Not available with vacuum valves.  
 7. Not available in external pilot type and vacuum valves.  
 8. When mounting the back pressure prevention valve, enter ○ in the back pressure prevention valve boxes of the designated stations in the above table.  
 Not available with the individual exhaust spacer and vacuum valve.  
 9. Not available in low-current type.  
 10. Not available in low-current type and tandem 3-port valves. In addition, only available when the wiring specification is a D-sub connector.  
 11. Can be selected only when the manifold type is A.  
 12. Can be selected only when the manifold type is AH.

Quantity	set	Delivery
----------	-----	----------

# F10, F15 Series

Monoblock Manifold F Type,  
Wire-Saving Type (Direct Piping Type)

Company name	
Contact person	
Order No.	

## Specifications Confirmation Form 1/2

• Fill in selections inside the thick-lined boxes.

**Manifold model**

F  M  F<sub>FH</sub> -  -

**Valve units**  
2 to  <sup>Note</sup>

Note: For the maximum number of units, check the table for maximum number of valve units by wiring specification on page 51.

**Valve size**  
10: 10mm width  
15: 15mm width

**Wiring connection specification**  
Blank: Packed wiring  
W : Double wiring

**Wiring specification**  
F100N : Flat cable connector 10-pin  
F101N : Flat cable connector 10-pin  
F200N : Flat cable connector 20-pin  
F201N : Flat cable connector 20-pin  
F260N : Flat cable connector 26-pin

(M2.6 mounting screw)  
D250N : D-sub connector 25-pin <sup>Note7</sup>  
D251N : D-sub connector 25-pin <sup>Note7</sup>

(4-40UNC mounting screw)  
D250NU : D-sub connector 25-pin <sup>Note8</sup>  
D251NU : D-sub connector 25-pin <sup>Note8</sup>

**Mounting valve model**

stn.  F  Valve size  T  Valve specification  <sup>Note 1</sup> -  <sup>Note 2</sup> - PN -  <sup>Note 4</sup> -  <sup>Note 3</sup>

**Manual override**  
Blank: Manual override button  
R : Manual override lever <sup>Note1</sup>

**Valve outlet type** <sup>Note2</sup>  
Can be selected only when the manifold type is F (metric).  
FJ : With dual use fitting block (F10: φ4 and φ6, F15: φ6 and φ8)  
FJ5 : With single use fitting block (F10: φ4, F15: φ6)  
FJ6 : With single use fitting block (F10: φ6, F15: φ8)  
FM : With female thread block (F10: M5X0.8, F15: Rc1/8)  
FJ5A : With single use fitting block, 3-port normally closed (NC) (F10: φ4, F15: φ6)  
FJ5B : With single use fitting block, 3-port normally open (NO) (F10: φ4, F15: φ6)  
FJ6A : With single use fitting block, 3-port normally closed (NC) (F10: φ6, F15: φ8)  
FJ6B : With single use fitting block, 3-port normally open (NO) (F10: φ6, F15: φ8)  
FMA : With female thread block, 3-port normally closed (NC) (F10: M5X0.8, F15: Rc1/8)  
FMB : With female thread block, 3-port normally open (NO) (F10: M5X0.8, F15: Rc1/8)

Can be selected only when the manifold type is FH (imperial).  
FMH : With female thread block (F10: 10-32UNF, F15: NPT1/8)  
FMAH : With female thread block, 3-port normally closed (NC) (F10: 10-32UNF, F15: NPT1/8)  
FMBH : With female thread block, 3-port normally open (NO) (F10: 10-32UNF, F15: NPT1/8)

**Voltage**  
DC12V <sup>Note5</sup>  
DC24V  
AC100V <sup>Note6</sup>  
AC120V <sup>Note6</sup>

**Individual air supply and exhaust apacer, stop valve** <sup>Note3</sup>  
Blank: No spacer and no stop valve  
NPM : Individual air supply spacer (with M5 female thread for F10)  
NP6 : Individual air supply spacer (with φ6 fitting for F15)  
NP8 : Individual air supply spacer (with φ8 fitting for F15)  
NRM : Individual exhaust spacer (with M5 female thread for F10)  
NR6 : Individual exhaust spacer (with φ6 fitting for F15)  
NR8 : Individual exhaust spacer (with φ8 fitting for F15)  
STP : With stop valve

**Back pressure prevention valve** <sup>Note4</sup>  
Blank: No back pressure prevention valve  
E1 : With back pressure prevention valve

Enter ○ in each designated station in tables on the next page.

# F10, F15 Series

## Monoblock Manifold F Type Wire-Saving Type (Direct Piping Type)

# Specifications Confirmation Form 2/2

※For specifying the valve and block-off plate to be mounted at each station, enter ○ in each applicable box below.

Mounting valve, block-off plate		Station	1	2	3	4	5	6	7	8	9	10	11	12	13	14	15	16	17	18	19	20
Mounting valve models	<input type="checkbox"/> <b>T0</b>	2-position, for single solenoid only																				
	<input type="checkbox"/> <b>T1</b>	2-position, single solenoid specification																				
	<input type="checkbox"/> <b>T2</b>	2-position, double solenoid specification																				
	<input type="checkbox"/> <b>T3</b>	3-position, closed center																				
	<input type="checkbox"/> <b>T4</b>	3-position, exhaust center																				
	<input type="checkbox"/> <b>T5</b>	3-position, pressure center																				
	<input type="checkbox"/> <b>TA</b>	Tandem 3-port (NC and NC)																				
	<input type="checkbox"/> <b>TB</b>	Tandem 3-port (NO and NO)																				
	<input type="checkbox"/> <b>TC</b>	Tandem 3-port (NC and NO)																				
	<input type="checkbox"/> <b>LT0</b>	(Low current type) 2-position, for single solenoid only																				
	<input type="checkbox"/> <b>LT1</b>	(Low current type) 2-position, single solenoid specification																				
	<input type="checkbox"/> <b>LT2</b>	(Low current type) 2-position, double solenoid specification																				
	<input type="checkbox"/> <b>LT3</b>	(Low current type) 3-position, closed center																				
	<input type="checkbox"/> <b>LT4</b>	(Low current type) 3-position, exhaust center																				
	<input type="checkbox"/> <b>LT5</b>	(Low current type) 3-position, pressure center																				
	<input type="checkbox"/> <b>LTA</b>	(Low current type) Tandem 3-port (NC and NC)																				
	<input type="checkbox"/> <b>LTB</b>	(Low current type) Tandem 3-port (NO and NO)																				
	<input type="checkbox"/> <b>LTC</b>	(Low current type) Tandem 3-port (NC and NO)																				
	<input type="checkbox"/> <b>BP</b>	Block-off plate																				
	Manual override (-R) Manual override lever <sup>Note1</sup>																					
Valve outlet type <sup>Note2</sup>	<input type="checkbox"/> <b>FJ</b>	With dual use fitting block																				
	<input type="checkbox"/> <b>FJ5</b>	With single use fitting block																				
	<input type="checkbox"/> <b>FJ6</b>	With single use fitting block																				
	<input type="checkbox"/> <b>FM</b>	With female thread block																				
	<input type="checkbox"/> <b>FJ5A</b>	With single use fitting block, 3-port normally closed (NC)																				
	<input type="checkbox"/> <b>FJ5B</b>	With single use fitting block, 3-port normally open (NO)																				
	<input type="checkbox"/> <b>FJ6A</b>	With single use fitting block, 3-port normally closed (NC)																				
	<input type="checkbox"/> <b>FJ6B</b>	With single use fitting block, 3-port normally open (NO)																				
	<input type="checkbox"/> <b>FMA</b>	With female thread block, 3-port normally closed (NC)																				
	<input type="checkbox"/> <b>FMB</b>	With female thread block, 3-port normally open (NO)																				
	<input type="checkbox"/> <b>FMH</b>	With female thread block																				
	<input type="checkbox"/> <b>FMAH</b>	With female thread block, 3-port normally closed (NC)																				
<input type="checkbox"/> <b>FMBH</b>	With female thread block, 3-port normally open (NO)																					
<input type="checkbox"/> <b>E1</b> <sup>Note4</sup> Back pressure prevention valve																						
<input type="checkbox"/> <b>NPM</b> Individual air supply spacer (with M5 female thread for F10)																						
<input type="checkbox"/> <b>NP6</b> Individual air supply spacer (with φ 6 fitting for F15)																						
<input type="checkbox"/> <b>NP8</b> Individual air supply spacer (with φ 8 fitting for F15)																						
<input type="checkbox"/> <b>NRM</b> Individual exhaust spacer (with M5 female thread for F10)																						
<input type="checkbox"/> <b>NR6</b> Individual exhaust spacer (with φ 6 fitting for F15)																						
<input type="checkbox"/> <b>NR8</b> Individual exhaust spacer (with φ 8 fitting for F15)																						
<input type="checkbox"/> <b>STP</b> With stop valve																						

- Notes: 1. To designate a manual override lever, enter ○ in the manual override boxes of the designated station in the above table.  
 When the valve specification is **T1** or **T2**, the manual override lever is placed only on the A side.  
 2. Select valve outlet type for each station, and enter ○ in the valve outlet type boxes of the above table. In addition, the 3-port specifications are only available in valve specifications **T0**, **T1**, and **T2**.  
 3. When mounting the individual air supply or exhaust spacer or stop valve, enter ○ in the spacer or stop valve boxes of the designated stations in the above table.  
 4. When mounting the back pressure prevention valve, enter ○ in the back pressure prevention valve boxes of the designated stations in the above table.  
 Not available with the individual exhaust spacer.  
 5. Not available in low-current type.  
 6. Not available in low-current type and tandem 3-port valves. In addition, only available when the wiring specification is a D-sub connector.  
 7. Can be selected only when the manifold type is F.  
 8. Can be selected only when the manifold type is FH.

Quantity	set	Delivery
----------	-----	----------

# F10, F15 Series

PC Board Manifold  
A Type (Base Piping Type)

Company name	
Contact person	
Order No.	

## Specifications Confirmation Form 1/2

• Fill in selections inside the thick-lined boxes.

**Manifold model**

F  M  AP   -  -

**Wiring specification**  
F200  
F201

**Pilot specification**  
Blank: Internal pilot manifold  
G : External pilot manifold

**Manifold outlet specification**  
J : With dual use fitting blocks  
M : With female thread blocks  
L : With selectable fitting blocks (metric)

**Wiring connection specification**  
Blank: Packed wiring  
S : Single wiring  
W : Double wiring

**Valve units**  
6 to 16 (only even-numbered units)  
Note: There should be 6 or 8 valve units, when the wiring connection specifications are -W (double wiring)

**Valve size**  
10: 10mm width  
15: 15mm width

**Mounting valve model**

stn.  F  Valve size  T  Valve specification  - Note 3 - A1 - PP - Note 4 - Note 8 - Note 5

**Operation type**  
Blank: Internal pilot type<sup>Note1</sup>  
G : External pilot type (for positive pressure)<sup>Note2</sup>  
V : External pilot type (for vacuum)<sup>Note2</sup>

**Manual override**  
Blank: Manual override button  
R : Manual override lever<sup>Note3</sup>

**Manifold fitting specifications**<sup>Note4</sup>  
Can be selected only when the manifold outlet specification is L.  
J5: Manifold side outlet port with single use fitting block (F10: φ4, F15: φ6)  
J6: Manifold side outlet port with single use fitting block (F10: φ6, F15: φ8)  
M: Manifold side outlet port with female thread block (F10: M5X0.8, F15: Rc1/8)  
J5A: Manifold side outlet port with single use fitting block, 3-port normally closed (NC) (F10: φ4, F15: φ6)  
J5B: Manifold side outlet port with single use fitting block, 3-port normally open (NO) (F10: φ4, F15: φ6)  
J6A: Manifold side outlet port with single use fitting block, 3-port normally closed (NC) (F10: φ6, F15: φ8)  
J6B: Manifold side outlet port with single use fitting block, 3-port normally open (NO) (F10: φ6, F15: φ8)  
MA: Manifold side outlet port with female thread block, 3-port normally closed (NC) (F10: M5X0.8, F15: Rc1/8)  
MB: Manifold side outlet port with female thread block, 3-port normally open (NO) (F10: M5X0.8, F15: Rc1/8)

**Individual air supply and exhaust apacer, stop valve**<sup>Note5</sup>  
Blank: No spacer and no stop valve  
NPM: Individual air supply spacer (with M5 female thread for F10)  
NP6: Individual air supply spacer (with φ6 fitting for F15)  
NP8: Individual air supply spacer (with φ8 fitting for F15)  
NRM: Individual exhaust spacer (with M5 female thread for F10)  
NR6: Individual exhaust spacer (with φ6 fitting for F15)  
NR8: Individual exhaust spacer (with φ8 fitting for F15)  
STP: With stop valve

**Back pressure prevention valve**<sup>Note8</sup>  
Blank: No back pressure prevention valve  
E1: With back pressure prevention valve

**Voltage**  
DC12V<sup>Note9</sup>  
DC24V

Enter ○ in each designated station in tables on the next page.

# F10, F15 Series

PC Board Manifold A Type (Base Piping Type)

## Specifications Confirmation Form 2/2

Wiring connection specifications are **-S** (for single wiring)

※For specifying the valve and block-off plate to be mounted at each station, enter ○ in each applicable box below.

Mounting valve, block-off plate	Station	1	2	3	4	5	6	7	8	9	10	11	12	13	14	15	16	
<input type="checkbox"/> <b>T0</b> 2-position, for single solenoid only																		
<input type="checkbox"/> <b>T1</b> 2-position, single solenoid specification																		
<input type="checkbox"/> <b>LT0</b> (Low current type) 2-position, for single solenoid only																		
<input type="checkbox"/> <b>LT1</b> (Low current type) 2-position, single solenoid specification																		
<input type="checkbox"/> <b>BPC</b> Block-off plate																		
Manual override (-R) Manual override lever <sup>Note3</sup>																		
Manifold fitting specification <sup>Note4</sup> (Manifold side outlet port)	<input type="checkbox"/> <b>J5</b> With single use fitting block																	
	<input type="checkbox"/> <b>J6</b> With single use fitting block																	
	<input type="checkbox"/> <b>M</b> With female thread block																	
	<input type="checkbox"/> <b>J5A</b> With single use fitting block, 3-port normally closed (NC)																	
	<input type="checkbox"/> <b>J5B</b> With single use fitting block, 3-port normally open (NO)																	
	<input type="checkbox"/> <b>J6A</b> With single use fitting block, 3-port normally closed (NC)																	
	<input type="checkbox"/> <b>J6B</b> With single use fitting block, 3-port normally open (NO)																	
	<input type="checkbox"/> <b>MA</b> With female thread block, 3-port normally closed (NC)																	
<input type="checkbox"/> <b>MB</b> With female thread block, 3-port normally open (NO)																		
<input type="checkbox"/> <b>E1</b> <sup>Note8</sup> Back pressure prevention valve																		
<input type="checkbox"/> <b>NPM</b> Individual air supply spacer (with M5 female thread for F10)																		
<input type="checkbox"/> <b>NP6</b> Individual air supply spacer (with φ 6 fitting for F15)																		
<input type="checkbox"/> <b>NP8</b> Individual air supply spacer (with φ 8 fitting for F15)																		
<input type="checkbox"/> <b>NRM</b> Individual exhaust spacer (with M5 female thread for F10)																		
<input type="checkbox"/> <b>NR6</b> Individual exhaust spacer (with φ 6 fitting for F15)																		
<input type="checkbox"/> <b>NR8</b> Individual exhaust spacer (with φ 8 fitting for F15)																		
<input type="checkbox"/> <b>STP</b> With stop valve <sup>Note1</sup>																		

Caution: Valve units can be selected from only the even-numbered units between 6 and 16.

Wiring connection specifications are **-W** (for double wiring)

※For specifying the valve and block-off plate to be mounted at each station, enter ○ in each applicable box below.

Mounting valve, block-off plate	Station	1	2	3	4	5	6	7	8
<input type="checkbox"/> <b>T0</b> 2-position, for single solenoid only									
<input type="checkbox"/> <b>T1</b> 2-position, single solenoid specification									
<input type="checkbox"/> <b>T2</b> 2-position, double solenoid specification									
<input type="checkbox"/> <b>T3</b> 3-position, closed center									
<input type="checkbox"/> <b>T4</b> <sup>Note6</sup> 3-position, exhaust center									
<input type="checkbox"/> <b>T5</b> <sup>Note6</sup> 3-position, pressure center									
<input type="checkbox"/> <b>TA</b> <sup>Note7</sup> Tandem 3-port (NC and NC)									
<input type="checkbox"/> <b>TB</b> <sup>Note7</sup> Tandem 3-port (NO and NO)									
<input type="checkbox"/> <b>TC</b> <sup>Note7</sup> Tandem 3-port (NC and NO)									
<input type="checkbox"/> <b>LT0</b> (Low current type) 2-position, for single solenoid only									
<input type="checkbox"/> <b>LT1</b> (Low current type) 2-position, single solenoid specification									
<input type="checkbox"/> <b>LT2</b> (Low current type) 2-position, double solenoid specification									
<input type="checkbox"/> <b>LT3</b> (Low current type) 3-position, closed center									
<input type="checkbox"/> <b>LT4</b> <sup>Note6</sup> (Low current type) 3-position, exhaust center									
<input type="checkbox"/> <b>LTS</b> <sup>Note6</sup> (Low current type) 3-position, pressure center									
<input type="checkbox"/> <b>LTA</b> <sup>Note7</sup> (Low current type) Tandem 3-port (NC and NC)									
<input type="checkbox"/> <b>LTB</b> <sup>Note7</sup> (Low current type) Tandem 3-port (NO and NO)									
<input type="checkbox"/> <b>LTC</b> <sup>Note7</sup> (Low current type) Tandem 3-port (NC and NO)									
<input type="checkbox"/> <b>BPC</b> Block-off plate									
Manual override (-R) Manual override lever <sup>Note3</sup>									
Manifold fitting specification <sup>Note4</sup> (Manifold side outlet port)	<input type="checkbox"/> <b>J5</b> With single use fitting block								
	<input type="checkbox"/> <b>J6</b> With single use fitting block								
	<input type="checkbox"/> <b>M</b> With female thread block								
	<input type="checkbox"/> <b>J5A</b> With single use fitting block, 3-port normally closed (NC)								
	<input type="checkbox"/> <b>J5B</b> With single use fitting block, 3-port normally open (NO)								
	<input type="checkbox"/> <b>J6A</b> With single use fitting block, 3-port normally closed (NC)								
	<input type="checkbox"/> <b>J6B</b> With single use fitting block, 3-port normally open (NO)								
	<input type="checkbox"/> <b>MA</b> With female thread block, 3-port normally closed (NC)								
<input type="checkbox"/> <b>MB</b> With female thread block, 3-port normally open (NO)									
<input type="checkbox"/> <b>E1</b> <sup>Note8</sup> Back pressure prevention valve									
<input type="checkbox"/> <b>NPM</b> Individual air supply spacer (with M5 female thread for F10)									
<input type="checkbox"/> <b>NP6</b> Individual air supply spacer (with φ 6 fitting for F15)									
<input type="checkbox"/> <b>NP8</b> Individual air supply spacer (with φ 8 fitting for F15)									
<input type="checkbox"/> <b>NRM</b> Individual exhaust spacer (with M5 female thread for F10)									
<input type="checkbox"/> <b>NR6</b> Individual exhaust spacer (with φ 6 fitting for F15)									
<input type="checkbox"/> <b>NR8</b> Individual exhaust spacer (with φ 8 fitting for F15)									
<input type="checkbox"/> <b>STP</b> With stop valve <sup>Note1</sup>									

Caution: There should be either 6 and 8 valves units.

- Notes:1. Cannot be mounted on the external pilot manifold.  
 2. Cannot be mounted on the internal pilot manifold.  
 3. To designate a manual override lever, enter ○ in the manual override boxes of the designated station in the left table.  
 4. When the manifold outlet specifications are **L** (with selectable fitting), select fitting specification for each station, and enter ○ in the manifold fitting specification boxes of the left table.  
 The 3-port specifications are only available in valve specification **T0**, **T1**, and **T2**.  
 5. When mounting the individual air supply or exhaust spacer or stop valve, enter ○ in the spacer or stop valve boxes of the designated stations in the left table.  
 6. Not available with vacuum valves.  
 7. Not available in external pilot type and vacuum valves.  
 8. When mounting the back pressure prevention valve, enter ○ in the back pressure prevention valve boxes of the designated stations in the left table. Not available with the individual exhaust spacer and vacuum valve.  
 9. Not available in low-current type.

Mounting valve models

Quantity	set	Delivery
----------	-----	----------

# F10, F15 Series

PC Board Manifold  
F Type (Direct Piping Type)

Company name	
Contact person	
Order No.	

## Specifications Confirmation Form 1/2

• Fill in selections inside the thick-lined boxes.

**Manifold model**

F  M  FP -  -

**Wiring connection specification**  
**S** : Single wiring  
**W** : Double wiring

**Wiring specification**  
**F200**  
**F201**

**Valve units**  
**6 to 16** (only even-numbered units)

Note: There should be 6 or 8 valve units, when the wiring connection specifications are **-W** (double wiring)

**Valve size**  
**10**: 10mm width  
**15**: 15mm width

**Mounting valve model**

stn.  F  Valve size  T  Valve specification  Note 1 - Note 2 - PP - Note 4 - Note 3 -

**Manual override**  
**Blank**: Manual override button  
**R** : Manual override lever<sup>Note1</sup>

**Valve outlet type**<sup>Note2</sup>  
**FJ** : With dual use fitting block (**F10**: φ4 and φ6, **F15**: φ6 and φ8)  
**FJ5** : With single use fitting block (**F10**: φ4, **F15**: φ6)  
**FJ6** : With single use fitting block (**F10**: φ6, **F15**: φ8)  
**FM** : With female thread block (**F10**: M5X0.8, **F15**: Rc1/8)  
**FJ5A** : With single use fitting block, 3-port normally closed (NC) (**F10**: φ4, **F15**: φ6)  
**FJ5B** : With single use fitting block, 3-port normally open (NO) (**F10**: φ4, **F15**: φ6)  
**FJ6A** : With single use fitting block, 3-port normally closed (NC) (**F10**: φ6, **F15**: φ8)  
**FJ6B** : With single use fitting block, 3-port normally open (NO) (**F10**: φ6, **F15**: φ8)  
**FMA** : With female thread block, 3-port normally closed (NC) (**F10**: M5X0.8, **F15**: Rc1/8)  
**FMB** : With female thread block, 3-port normally open (NO) (**F10**: M5X0.8, **F15**: Rc1/8)

**Individual air supply and exhaust apacer, stop valve**<sup>Note3</sup>  
**Blank**: No spacer and no stop valve  
**NPM** : Individual air supply spacer (with M5 female thread for F10)  
**NP6** : Individual air supply spacer (with φ6 fitting for F15)  
**NP8** : Individual air supply spacer (with φ8 fitting for F15)  
**NRM** : Individual exhaust spacer (with M5 female thread for F10)  
**NR6** : Individual exhaust spacer (with φ6 fitting for F15)  
**NR8** : Individual exhaust spacer (with φ8 fitting for F15)  
**STP** : With stop valve

**Back pressure prevention valve**<sup>Note4</sup>  
**Blank**: No back pressure prevention valve  
**E1** : With back pressure prevention valve

**Voltage**  
**DC12V**<sup>Note5</sup>  
**DC24V**

Enter ○ in each designated station in tables on the next page.

# F10, F15 Series

PC Board Manifold F Type (Direct Piping Type)

## Specifications Confirmation Form 2/2

Wiring connection specifications are **-S** (for single wiring)

※For specifying the valve and block-off plate to be mounted at each station, enter ○ in each applicable box below.

Mounting valve, block-off plate		Station	1	2	3	4	5	6	7	8	9	10	11	12	13	14	15	16
<input type="checkbox"/>	<b>T0</b>	2-position, for single solenoid only																
<input type="checkbox"/>	<b>T1</b>	2-position, single solenoid specification																
<input type="checkbox"/>	<b>LT0</b>	(Low current type) 2-position, for single solenoid only																
<input type="checkbox"/>	<b>LT1</b>	(Low current type) 2-position, single solenoid specification																
<input type="checkbox"/>	<b>BPC</b>	Block-off plate																
Manual override (-R) Manual override lever <sup>Note1</sup>																		
Valve outlet type <sup>Note2</sup>	<b>FJ</b>	With dual use fitting block																
	<b>FJ5</b>	With single use fitting block																
	<b>FJ6</b>	With single use fitting block																
	<b>FM</b>	With female thread block																
	<b>FJ5A</b>	With single use fitting block, 3-port normally closed (NC)																
	<b>FJ5B</b>	With single use fitting block, 3-port normally open (NO)																
	<b>FJ6A</b>	With single use fitting block, 3-port normally closed (NC)																
	<b>FJ6B</b>	With single use fitting block, 3-port normally open (NO)																
	<b>FMA</b>	With female thread block, 3-port normally closed (NC)																
<b>FMB</b>	With female thread block, 3-port normally open (NO)																	
<b>E1</b> <sup>Note4</sup>	Back pressure prevention valve																	
<b>NPM</b>	Individual air supply spacer (with M5 female thread for F10)																	
<b>NP6</b>	Individual air supply spacer (with φ 6 fitting for F15)																	
<b>NP8</b>	Individual air supply spacer (with φ 8 fitting for F15)																	
<b>NRM</b>	Individual exhaust spacer (with M5 female thread for F10)																	
<b>NR6</b>	Individual exhaust spacer (with φ 6 fitting for F15)																	
<b>NR8</b>	Individual exhaust spacer (with φ 8 fitting for F15)																	
<b>STP</b>	With stop valve																	

Caution: Valve units can be selected from only the even-numbered units between 6 and 16.

Wiring connection specifications are **-W** (for double wiring)

※For specifying the valve and block-off plate to be mounted at each station, enter ○ in each applicable box below.

Mounting valve, block-off plate		Station	1	2	3	4	5	6	7	8
<input type="checkbox"/>	<b>T0</b>	2-position, for single solenoid only								
<input type="checkbox"/>	<b>T1</b>	2-position, single solenoid specification								
<input type="checkbox"/>	<b>T2</b>	2-position, double solenoid specification								
<input type="checkbox"/>	<b>T3</b>	3-position, closed center								
<input type="checkbox"/>	<b>T4</b>	3-position, exhaust center								
<input type="checkbox"/>	<b>T5</b>	3-position, pressure center								
<input type="checkbox"/>	<b>TA</b>	Tandem 3-port (NC and NC)								
<input type="checkbox"/>	<b>TB</b>	Tandem 3-port (NO and NO)								
<input type="checkbox"/>	<b>TC</b>	Tandem 3-port (NC and NO)								
<input type="checkbox"/>	<b>LT0</b>	(Low current type) 2-position, for single solenoid only								
<input type="checkbox"/>	<b>LT1</b>	(Low current type) 2-position, single solenoid specification								
<input type="checkbox"/>	<b>LT2</b>	(Low current type) 2-position, double solenoid specification								
<input type="checkbox"/>	<b>LT3</b>	(Low current type) 3-position, closed center								
<input type="checkbox"/>	<b>LT4</b>	(Low current type) 3-position, exhaust center								
<input type="checkbox"/>	<b>LT5</b>	(Low current type) 3-position, pressure center								
<input type="checkbox"/>	<b>LTA</b>	(Low current type) Tandem 3-port (NC and NC)								
<input type="checkbox"/>	<b>LTB</b>	(Low current type) Tandem 3-port (NO and NO)								
<input type="checkbox"/>	<b>LTC</b>	(Low current type) Tandem 3-port (NC and NO)								
<input type="checkbox"/>	<b>BPC</b>	Block-off plate								
Manual override (-R) Manual override lever <sup>Note1</sup>										
Valve outlet type <sup>Note2</sup>	<b>FJ</b>	With dual use fitting block								
	<b>FJ5</b>	With single use fitting block								
	<b>J6</b>	With single use fitting block								
	<b>M</b>	With female thread block								
	<b>J5A</b>	With single use fitting block, 3-port normally closed (NC)								
	<b>J5B</b>	With single use fitting block, 3-port normally open (NO)								
	<b>J6A</b>	With single use fitting block, 3-port normally closed (NC)								
	<b>J6B</b>	With single use fitting block, 3-port normally open (NO)								
	<b>MA</b>	With female thread block, 3-port normally closed (NC)								
<b>MB</b>	With female thread block, 3-port normally open (NO)									
<b>E1</b> <sup>Note4</sup>	Back pressure prevention valve									
<b>NPM</b>	Individual air supply spacer (with M5 female thread for F10)									
<b>NP6</b>	Individual air supply spacer (with φ 6 fitting for F15)									
<b>NP8</b>	Individual air supply spacer (with φ 8 fitting for F15)									
<b>NRM</b>	Individual exhaust spacer (with M5 female thread for F10)									
<b>NR6</b>	Individual exhaust spacer (with φ 6 fitting for F15)									
<b>NR8</b>	Individual exhaust spacer (with φ 8 fitting for F15)									
<b>STP</b>	With stop valve									

Caution: There should be either 6 and 8 valves units.

- Notes: 1. To designate a manual override lever, enter ○ in the manual override boxes of the designated station in the left table.  
 2. Select fitting for each station, and enter ○ in the valve outlet type boxes of the above table. In addition, the 3-port specifications are only available in valve specifications **T0**, **T1**, and **T2**.  
 3. When mounting the individual air supply or exhaust spacer or stop valve, enter ○ in the spacer or stop valve boxes of the designated stations in the left table.  
 4. When mounting the back pressure prevention valve, enter ○ in the back pressure prevention valve boxes of the designated stations in the left table. Not available with the individual exhaust spacer and vacuum valve.  
 5. Not available in low-current type.

Mounting valve models

Quantity	set	Delivery
----------	-----	----------

# F10, F15 Series

## Split Manifold Non-Plug-in Type

# Specifications

# Confirmation Form 1/2

Company name	
Contact person	
Order No.	

• Fill in selections inside the thick-lined boxes.

Manifold model

F  M  N  NH  -

**Pilot specification**  
**Blank**: Internal pilot manifold  
**G** : External pilot manifold

**Manifold outlet specification**  
**J** : With dual use fitting blocks  
**M** : With female thread blocks  
**L** : With selectable fitting blocks  
**Blank**: With plates (direct piping type)

Valve units  
 2 to 20

Valve size  
**10**: 10mm width  
**15**: 15mm width

**Piping block specification (air supply and exhaust)**

Can be selected only when the manifold type is **N** (metric).

- JR** : With dual use fitting, right-side mounting
- JL** : With dual use fitting, left-side mounting
- JD** : With dual use fitting, both-side mounting
- MR** : With female thread, right-side mounting
- ML** : With female thread, left-side mounting
- MD** : With female thread, both-side mounting
- J5R** : With single use fitting  $\phi$  8, right-side mounting
- J6R** : With single use fitting  $\phi$  10, right-side mounting
- J5L** : With single use fitting  $\phi$  8, left-side mounting
- J6L** : With single use fitting  $\phi$  10, left-side mounting
- J5D** : With single use fitting  $\phi$  8, both-side mounting
- J6D** : With single use fitting  $\phi$  10, both-side mounting

Can be selected only when the manifold type is **NH** (imperial).

- MRH** : With female thread, right-side mounting
- MLH** : With female thread, left-side mounting
- MDH** : With female thread, both-side mounting

stn.  F  Valve size  T  Valve specification  - Note 3 -  - Note 4 -  - Note 5 -  - Note 10 -  - Note 6 -  - Note 7 -

When manifold outlet specifications are **J**, **M**, or **L**.

**Operation type**  
**Blank**: Internal pilot type<sup>Note1</sup>  
**G** : External pilot type<sup>Note2</sup>

**Manual override**  
**Blank**: Manual override button  
**R** : Manual override lever<sup>Note3</sup>

**Manifold fitting specifications**<sup>Note5</sup>  
 Can be selected only when the manifold type is **N** and the manifold outlet specification is **L** (with selectable fitting blocks (metric))  
**J5** : Manifold side outlet port with single use fitting block<sup>Note13</sup> (**F10**:  $\phi$  4, **F15**:  $\phi$  6)  
**J6** : Manifold side outlet port with single use fitting block<sup>Note13</sup> (**F10**:  $\phi$  6, **F15**:  $\phi$  8)  
**M** : Manifold side outlet port with female thread block<sup>Note13</sup> (**F10**: M5X0.8, **F15**: Rc1/8)  
**J5A** : Manifold side outlet port with single use fitting block, 3-port normally closed (NC)<sup>Note13</sup> (**F10**:  $\phi$  4, **F15**:  $\phi$  6)  
**J5B** : Manifold side outlet port with single use fitting block, 3-port normally open (NO)<sup>Note13</sup> (**F10**:  $\phi$  4, **F15**:  $\phi$  6)  
**J6A** : Manifold side outlet port with single use fitting block, 3-port normally closed (NC)<sup>Note13</sup> (**F10**:  $\phi$  6, **F15**:  $\phi$  8)  
**J6B** : Manifold side outlet port with single use fitting block, 3-port normally open (NO)<sup>Note13</sup> (**F10**:  $\phi$  6, **F15**:  $\phi$  8)  
**MA** : Manifold side outlet port with female thread block, 3-port normally closed (NC)<sup>Note13</sup> (**F10**: M5X0.8, **F15**: Rc1/8)  
**MB** : Manifold side outlet port with female thread block, 3-port normally open (NO)<sup>Note13</sup> (**F10**: M5X0.8, **F15**: Rc1/8)  
 Can be selected only when the manifold type is **NH** and the manifold outlet specification is **L** (with selectable fitting blocks (imperial))  
**MH** : Manifold side outlet port with female thread block<sup>Note14</sup> (**F10**: 10-32UNF, **F15**: NPT1/8)  
**MAH** : Manifold side outlet port with female thread block, 3-port normally closed (NC)<sup>Note14</sup> (**F10**: 10-32UNF, **F15**: NPT1/8)  
**MBH** : Manifold side outlet port with female thread block, 3-port normally open (NO)<sup>Note14</sup> (**F10**: 10-32UNF, **F15**: NPT1/8)

**Wiring specification**  
**PN** : S type plug connector, Without connector  
**PS** : S type plug connector, Lead wire length 300mm [11.8in.]  
**PS3** : S type plug connector, Lead wire length 3000mm [118in.]  
**CPS** : Pre-wired positive common terminal S type plug connector, Lead wire length 300mm [11.8in.]  
**CPS3** : Pre-wired positive common terminal S type plug connector, Lead wire length 3000mm [118in.]

**Valve outlet type**  
**A1** : With plate (When manifold outlet specification are **J**, **M**, or **L**, the valve type should be **A1**.)  
 Can be selected only when the manifold type is **N** and the manifold outlet specification is "Blank" (metric).  
**FJ** : With dual use fitting block<sup>Note4</sup> (**F10**:  $\phi$  4 and  $\phi$  6, **F15**:  $\phi$  6 and  $\phi$  8)  
**FJ5** : With single use fitting block<sup>Note4</sup> (**F10**:  $\phi$  4, **F15**:  $\phi$  6)  
**FJ6** : With single use fitting block<sup>Note4</sup> (**F10**:  $\phi$  6, **F15**:  $\phi$  8)  
**FM** : With female thread block<sup>Note4</sup> (**F10**: M5X0.8, **F15**: Rc1/8)  
**FJ5A** : With single use fitting block, 3-port normally closed (NC)<sup>Note4</sup> (**F10**:  $\phi$  4, **F15**:  $\phi$  6)  
**FJ5B** : With single use fitting block, 3-port normally open (NO)<sup>Note4</sup> (**F10**:  $\phi$  4, **F15**:  $\phi$  6)  
**FJ6A** : With single use fitting block, 3-port normally closed (NC)<sup>Note4</sup> (**F10**:  $\phi$  6, **F15**:  $\phi$  8)  
**FJ6B** : With single use fitting block, 3-port normally open (NO)<sup>Note4</sup> (**F10**:  $\phi$  6, **F15**:  $\phi$  8)  
**FMA** : With female thread block, 3-port normally closed (NC)<sup>Note4</sup> (**F10**: M5X0.8, **F15**: Rc1/8)  
**FMB** : With female thread block, 3-port normally open (NO)<sup>Note4</sup> (**F10**: M5X0.8, **F15**: Rc1/8)  
 Can be selected only when the manifold type is **NH** and the manifold outlet specification is "Blank" (imperial).  
**FMH** : With female thread block<sup>Note4</sup> (**F10**: 10-32UNF, **F15**: NPT1/8)  
**FMAH** : With female thread block, 3-port normally closed (NC)<sup>Note4</sup> (**F10**: 10-32UNF, **F15**: NPT1/8)  
**FMBH** : With female thread block, 3-port normally open (NO)<sup>Note4</sup> (**F10**: 10-32UNF, **F15**: NPT1/8)

**Port isolator**  
**Blank**: No port isolator  
**SP** : For 1(P) port<sup>Note7</sup>  
**SR** : For 3(R2), 5(R1) ports<sup>Note7</sup>  
**SA** : For 1(P), 3(R2), 5(R1) ports<sup>Note7</sup>

**Individual air supply and exhaust apacer**<sup>Note6</sup>  
**Blank**: No spacer  
**NPM** : Individual air supply spacer (with M5 female thread for F10)  
**NP6** : Individual air supply spacer (with  $\phi$  6 fitting for F15)  
**NP8** : Individual air supply spacer (with  $\phi$  8 fitting for F15)  
**NRM** : Individual exhaust spacer (with M5 female thread for F10)  
**NR6** : Individual exhaust spacer (with  $\phi$  6 fitting for F15)  
**NR8** : Individual exhaust spacer (with  $\phi$  8 fitting for F15)

**Back pressure prevention valve**<sup>Note10</sup>  
**Blank**: No back pressure prevention valve  
**E2** : With back pressure prevention valve

**Voltage**  
**DC12V**<sup>Note11</sup>  
**DC24V**  
**AC100V**<sup>Note12</sup>  
**AC120V**<sup>Note12</sup>

Enter  $\bigcirc$  in each designated station in tables on the next page.

# F10, F15 Series

## Split Manifold Non-Plug-in Type

# Specifications Confirmation Form 2/2

※For specifying the valve and block-off plate to be mounted at each station, enter ○ in each applicable box below.

Mounting valve, block-off plate		Station	1	2	3	4	5	6	7	8	9	10	11	12	13	14	15	16	17	18	19	20	
Mounting valve models	F <input type="checkbox"/> <b>T0</b>	2-position, for single solenoid only																					
	F <input type="checkbox"/> <b>T1</b>	2-position, single solenoid specification																					
	F <input type="checkbox"/> <b>T2</b>	2-position, double solenoid specification																					
	F <input type="checkbox"/> <b>T3</b>	3-position, closed center																					
	F <input type="checkbox"/> <b>T4</b>	3-position, exhaust center																					
	F <input type="checkbox"/> <b>T5</b>	3-position, pressure center																					
	F <input type="checkbox"/> <b>TA</b> <sup>Note9</sup>	Tandem 3-port (NC and NC)																					
	F <input type="checkbox"/> <b>TB</b> <sup>Note9</sup>	Tandem 3-port (NO and NO)																					
	F <input type="checkbox"/> <b>TC</b> <sup>Note9</sup>	Tandem 3-port (NC and NO)																					
	F <input type="checkbox"/> <b>LT0</b>	(Low current type) 2-position, for single solenoid only																					
	F <input type="checkbox"/> <b>LT1</b>	(Low current type) 2-position, single solenoid specification																					
	F <input type="checkbox"/> <b>LT2</b>	(Low current type) 2-position, double solenoid specification																					
	F <input type="checkbox"/> <b>LT3</b>	(Low current type) 3-position, closed center																					
	F <input type="checkbox"/> <b>LT4</b>	(Low current type) 3-position, exhaust center																					
	F <input type="checkbox"/> <b>LT5</b>	(Low current type) 3-position, pressure center																					
	F <input type="checkbox"/> <b>LTA</b> <sup>Note9</sup>	(Low current type) Tandem 3-port (NC and NC)																					
	F <input type="checkbox"/> <b>LTB</b> <sup>Note9</sup>	(Low current type) Tandem 3-port (NO and NO)																					
	F <input type="checkbox"/> <b>LTC</b> <sup>Note9</sup>	(Low current type) Tandem 3-port (NC and NO)																					
	F <input type="checkbox"/> <b>BPN</b>	Block-off plate																					
	Manual override (-R) Manual override lever <sup>Note3</sup>																						
	Valve outlet type <sup>Note4</sup>	<b>FJ</b>	With dual use fitting block																				
		<b>FJ5</b>	With single use fitting block																				
		<b>FJ6</b>	With single use fitting block																				
		<b>FM</b>	With female thread block																				
		<b>FJ5A</b>	With single use fitting block, 3-port normally closed (NC)																				
		<b>FJ5B</b>	With single use fitting block, 3-port normally open (NO)																				
		<b>FJ6A</b>	With single use fitting block, 3-port normally closed (NC)																				
		<b>FJ6B</b>	With single use fitting block, 3-port normally open (NO)																				
		<b>FMA</b>	With female thread block, 3-port normally closed (NC)																				
		<b>FMB</b>	With female thread block, 3-port normally open (NO)																				
		<b>FMH</b>	With female thread block																				
		<b>FMAH</b>	With female thread block, 3-port normally closed (NC)																				
		<b>FMBH</b>	With female thread block, 3-port normally open (NO)																				
		Manifold fitting specification <sup>Note5</sup> (Manifold side outlet port)	<b>J5</b>	With single use fitting block																			
	<b>J6</b>		With single use fitting block																				
	<b>M</b>		With female thread block																				
	<b>J5A</b>		With single use fitting block, 3-port normally closed (NC)																				
<b>J5B</b>	With single use fitting block, 3-port normally open (NO)																						
<b>J6A</b>	With single use fitting block, 3-port normally closed (NC)																						
<b>J6B</b>	With single use fitting block, 3-port normally open (NO)																						
<b>MA</b>	With female thread block, 3-port normally closed (NC)																						
<b>MB</b>	With female thread block, 3-port normally open (NO)																						
<b>MH</b>	With female thread block																						
<b>MAH</b>	With female thread block, 3-port normally closed (NC)																						
<b>MBH</b>	With female thread block, 3-port normally open (NO)																						
<b>E2</b> <sup>Note10</sup>	Back pressure prevention valve																						
<b>NPM</b>	Individual air supply spacer (with M5 female thread for F10)																						
<b>NP6</b>	Individual air supply spacer (with φ 6 fitting for F15)																						
<b>NP8</b>	Individual air supply spacer (with φ 8 fitting for F15)																						
<b>NRM</b>	Individual exhaust spacer (with M5 female thread for F10)																						
<b>NR6</b>	Individual exhaust spacer (with φ 6 fitting for F15)																						
<b>NR8</b>	Individual exhaust spacer (with φ 8 fitting for F15)																						
Port isolator (-SP) For 1(P) port <sup>Note8</sup>																							
Port isolator (-SR) For 3(R2), 5(R1) ports <sup>Note8</sup>																							
Port isolator (-SA) For 1(P), 3(R2), 5(R1) ports <sup>Note8</sup>																							

- Notes: 1. Cannot be mounted on the external pilot manifold.  
 2. Cannot be mounted on the internal pilot manifold.  
 3. To designate a manual override lever, enter ○ in the manual override boxes of the designated stations in the above table.  
 4. When the manifold outlet specifications are "Blank", select fitting specification for each station, and enter ○ in the valve outlet type boxes of the above table. The 3-port specifications are only available in valve specifications **T0**, **T1**, and **T2**.  
 5. When the manifold outlet specifications are **L** (with selectable fitting), select manifold fitting specification for each station, and enter ○ in the manifold fitting specification boxes of the above table. The 3-port specifications are only available in valve specifications **T0**, **T1**, and **T2**.  
 6. When mounting the individual air supply or exhaust spacer, enter ○ in the spacer boxes of the designated stations in the above table.  
 7. To designate a port isolator, enter ○ in one box of the designated stations in the above table.  
 8. Port isolators can be installed only when piping blocks are mounted on both sides. In addition, only 1 port isolator can be mounted in 1 manifold for **-SA**, or 1 each port isolator for **-SP** and **-SR** for a total of 2 locations. When shipping, the designated port isolators are installed between the designated station and the station to its immediate left (the next smaller stn. No.).  
 9. Not available in external pilot type.  
 10. When mounting the back pressure prevention valve, enter ○ in the back pressure prevention valve boxes of the designated stations in the above table. Not available with the individual exhaust spacer.  
 11. Not available in low-current type.  
 12. Not available in low-current type and tandem 3-port valves.

Quantity	set	Delivery
----------	-----	----------

# F10, F15 Series

## Split Manifold Plug-in Type

# Specifications

# Confirmation Form 1/2

Company name	
Contact person	
Order No.	

• Fill in selections inside the thick-lined boxes.

	<b>F</b> <input type="text"/> <b>M</b> <input type="text"/> <b>P</b> <input type="text"/> <b>PH</b> <input type="text"/> - <input type="text"/> - <input type="text"/> - <input type="text"/> - <input type="text"/> - <input type="text"/>					
Manifold model	<b>Valve size</b> 10: 10mm width 15: 15mm width  <b>Valve units</b> 2 to <input type="text"/> <small>Note</small> <small>Note: For the maximum number of units, see the table for maximum number of valve units by wiring specification, on P. 66</small>	<b>Pilot specification</b> Blank: Internal pilot manifold G : External pilot manifold	<b>Wiring connection specification</b> Blank: Packed wiring W : Double wiring	<b>Wiring position (wiring block)</b> Blank: Left-side mounting R : Right-side mounting	<b>Voltage</b> DC12V <small>Note9</small> DC24V AC100V <small>Note10</small>	
	<b>Manifold outlet specification</b> J : With dual use fitting blocks M : With female thread blocks L : With selectable fitting blocks Blank: With plates (direct piping type)		<b>Wiring specification</b> <connector top surface wiring> F100 : Flat cable connector 10-pin F100N : Flat cable connector 10-pin without power terminal F101 : Flat cable connector 10-pin F101N : Flat cable connector 10-pin without power terminal F200 : Flat cable connector 20-pin F200N : Flat cable connector 20-pin without power terminal F201 : Flat cable connector 20-pin F201N : Flat cable connector 20-pin without power terminal F260 : Flat cable connector 26-pin F260N : Flat cable connector 26-pin without power terminal	<connector side surface wiring> F100E : Flat cable connector 10-pin F100EN : Flat cable connector 10-pin without power terminal F101E : Flat cable connector 10-pin F101EN : Flat cable connector 10-pin without power terminal F200E : Flat cable connector 20-pin F200EN : Flat cable connector 20-pin without power terminal F201E : Flat cable connector 20-pin F201EN : Flat cable connector 20-pin without power terminal F260E : Flat cable connector 26-pin F260EN : Flat cable connector 26-pin without power terminal		
	<b>Piping block specification (air supply and exhaust)</b> Can be selected only when the manifold type is <b>P</b> (metric). JR : With dual use fitting, right-side mounting JL : With dual use fitting, left-side mounting JD : With dual use fitting, both-side mounting MR : With female thread, right-side mounting ML : With female thread, left-side mounting MD : With female thread, both-side mounting J5R : With single use fitting φ 8, right-side mounting J6R : With single use fitting φ 10, right-side mounting J5L : With single use fitting φ 8, left-side mounting J6L : With single use fitting φ 10, left-side mounting J5D : With single use fitting φ 8, both-side mounting J6D : With single use fitting φ 10, both-side mounting		(M2.6 mounting screw) D250 : D-sub connector 25-pin <small>Note13</small> D250N : D-sub connector 25-pin without power terminal <small>Note13</small> D251 : D-sub connector 25-pin <small>Note13</small> D251N : D-sub connector 25-pin without power terminal <small>Note13</small> (4-40UNC mounting screw) D250U : D-sub connector 25-pin <small>Note14</small> D251U : D-sub connector 25-pin <small>Note14</small> D370NU : D-sub connector 37-pin without power terminal <small>Note14</small>	(M2.6 mounting screw) D250E : D-sub connector 25-pin <small>Note13</small> D250EN : D-sub connector 25-pin without power terminal <small>Note13</small> D251E : D-sub connector 25-pin <small>Note13</small> D251EN : D-sub connector 25-pin without power terminal <small>Note13</small> (4-40UNC mounting screw) D250EU : D-sub connector 25-pin <small>Note14</small> D251EU : D-sub connector 25-pin <small>Note14</small>		
	Can be selected only when the manifold type is <b>PH</b> (imperial). MRH : With female thread, right-side mounting MLH : With female thread, left-side mounting MDH : With female thread, both-side mounting		T200: Terminal block 19 terminals			

	stn. <input type="text"/> <b>F</b> <input type="text"/> Valve size <input type="text"/> <b>T</b> <input type="text"/> Valve specification <input type="text"/> - <input type="text"/> <small>Note3</small> - <input type="text"/> <small>Note4</small> - <input type="text"/> <small>Note5</small> - <input type="text"/> <small>Note12</small> - <input type="text"/> <small>Note6</small> - <input type="text"/> <small>Note7</small> - <input type="text"/>					
Mounting valve model	<b>Operation type</b> Blank: Internal pilot type <small>Note1</small> G : External pilot type <small>Note2</small>	<b>Manual override</b> Blank: Manual override button R : Manual override lever <small>Note3</small>	When manifold outlet specifications are J, M, or L.	<b>Voltage</b> DC12V <small>Note9</small> DC24V AC100V <small>Note10</small> AC120V <small>Note10</small>		
	<b>Valve outlet type</b> A1 : With plate (When manifold outlet specification are J, M, or L, the valve type should be A1.)  Can be selected only when the manifold type is <b>P</b> and the manifold outlet specification is "Blank" (metric). FJ : With dual use fitting block <small>Note4</small> (F10: φ 4 and φ 6, F15: φ 6 and φ 8) FJ5 : With single use fitting block <small>Note4</small> (F10: φ 4, F15: φ 6) FJ6 : With single use fitting block <small>Note4</small> (F10: φ 6, F15: φ 8) FM : With female thread block <small>Note4</small> (F10: M5X0.8, F15: Rc1/8) FJ5A : With single use fitting block, 3-port normally closed (NC) <small>Note4</small> (F10: φ 4, F15: φ 6) FJ5B : With single use fitting block, 3-port normally open (NO) <small>Note4</small> (F10: φ 4, F15: φ 6) FJ6A : With single use fitting block, 3-port normally closed (NC) <small>Note4</small> (F10: φ 6, F15: φ 8) FJ6B : With single use fitting block, 3-port normally open (NO) <small>Note4</small> (F10: φ 6, F15: φ 8) FMA : With female thread block, 3-port normally closed (NC) <small>Note4</small> (F10: M5X0.8, F15: Rc1/8) FMB : With female thread block, 3-port normally open (NO) <small>Note4</small> (F10: M5X0.8, F15: Rc1/8)		<b>Port isolator</b> Blank: No port isolator SP : For 1(P) port <small>Note7</small> SR : For 3(R2), 5(R1) ports <small>Note7</small> SA : For 1(P), 3(R2), 5(R1) ports <small>Note7</small>	<b>Individual air supply and exhaust apacer</b> <small>Note6</small> Blank: No spacer PPM : Individual air supply spacer (with M5 female thread for F10) PP6 : Individual air supply spacer (with φ 6 fitting for F15) PP8 : Individual air supply spacer (with φ 8 fitting for F15) PRM : Individual exhaust spacer (with M5 female thread for F10) PR6 : Individual exhaust spacer (with φ 6 fitting for F15) PR8 : Individual exhaust spacer (with φ 8 fitting for F15)		
	Can be selected only when the manifold type is <b>PH</b> and the manifold outlet specification is "Blank" (imperial). FMH : With female thread block <small>Note4</small> (F10: 10-32UNF, F15: NPT1/8) FMAH : With female thread block, 3-port normally closed (NC) <small>Note4</small> (F10: 10-32UNF, F15: NPT1/8) FMBH : With female thread block, 3-port normally open (NO) <small>Note4</small> (F10: 10-32UNF, F15: NPT1/8)		<b>Back pressure prevention valve</b> <small>Note12</small> Blank: No back pressure prevention valve E2 : With back pressure prevention valve			
	<b>Manifold fitting specifications</b> <small>Note5</small> Can be selected only when the manifold type is <b>P</b> and the manifold outlet specification is <b>L</b> (with selectable fitting blocks (metric)) J5 : Manifold side outlet port with single use fitting block (F10: φ 4, F15: φ 6) J6 : Manifold side outlet port with single use fitting block (F10: φ 6, F15: φ 8) M : Manifold side outlet port with female thread block (F10: M5X0.8, F15: Rc1/8) J5A : Manifold side outlet port with single use fitting block, 3-port normally closed (NC) (F10: φ 4, F15: φ 6) J5B : Manifold side outlet port with single use fitting block, 3-port normally open (NO) (F10: φ 4, F15: φ 6) J6A : Manifold side outlet port with single use fitting block, 3-port normally closed (NC) (F10: φ 6, F15: φ 8) J6B : Manifold side outlet port with single use fitting block, 3-port normally open (NO) (F10: φ 6, F15: φ 8) MA : Manifold side outlet port with female thread block, 3-port normally closed (NC) (F10: M5X0.8, F15: Rc1/8) MB : Manifold side outlet port with female thread block, 3-port normally open (NO) (F10: M5X0.8, F15: Rc1/8)					
	Can be selected only when manifold type is <b>PH</b> and manifold outlet specification is <b>L</b> (with selectable fitting blocks (imperial)) MH : Manifold side outlet port with female thread block (F10: 10-32UNF, F15: NPT1/8) MAH : Manifold side outlet port with female thread block, 3-port normally closed (NC) (F10: 10-32UNF, F15: NPT1/8) MBH : Manifold side outlet port with female thread block, 3-port normally open (NO) (F10: 10-32UNF, F15: NPT1/8)					

Enter ○ in each designated station in tables on the next page.

# F10, F15 Series

## Split Manifold Plug-in Type

# Specifications Confirmation Form 2/2

※For specifying the valve and block-off plate to be mounted at each station, enter ○ in each applicable box below.

Mounting valve, block-off plate		Station	1	2	3	4	5	6	7	8	9	10	11	12	13	14	15	16	17	18	19	20		
F	<input type="checkbox"/> T0	2-position, for single solenoid only																						
F	<input type="checkbox"/> T1	2-position, single solenoid specification																						
F	<input type="checkbox"/> T2	2-position, double solenoid specification																						
F	<input type="checkbox"/> T3	3-position, closed center																						
F	<input type="checkbox"/> T4	3-position, exhaust center																						
F	<input type="checkbox"/> T5	3-position, pressure center																						
F	<input type="checkbox"/> TA <sup>Note11</sup>	Tandem 3-port (NC and NC)																						
F	<input type="checkbox"/> TB <sup>Note11</sup>	Tandem 3-port (NO and NO)																						
F	<input type="checkbox"/> TC <sup>Note11</sup>	Tandem 3-port (NC and NO)																						
F	<input type="checkbox"/> LT0	(Low current type) 2-position, for single solenoid only																						
F	<input type="checkbox"/> LT1	(Low current type) 2-position, single solenoid specification																						
F	<input type="checkbox"/> LT2	(Low current type) 2-position, double solenoid specification																						
F	<input type="checkbox"/> LT3	(Low current type) 3-position, closed center																						
F	<input type="checkbox"/> LT4	(Low current type) 3-position, exhaust center																						
F	<input type="checkbox"/> LT5	(Low current type) 3-position, pressure center																						
F	<input type="checkbox"/> LTA <sup>Note11</sup>	(Low current type) Tandem 3-port (NC and NC)																						
F	<input type="checkbox"/> LTB <sup>Note11</sup>	(Low current type) Tandem 3-port (NO and NO)																						
F	<input type="checkbox"/> LTC <sup>Note11</sup>	(Low current type) Tandem 3-port (NC and NO)																						
F	<input type="checkbox"/> BPP	Block-off plate																						
Manual override (-R) Manual override lever <sup>Note3</sup>																								
Mounting valve models	Valve outlet type <sup>Note4</sup>	FJ	With dual use fitting block																					
		FJ5	With single use fitting block																					
		FJ6	With single use fitting block																					
		FM	With female thread block																					
		FJ5A	With single use fitting block, 3-port normally closed (NC)																					
		FJ5B	With single use fitting block, 3-port normally open (NO)																					
		FJ6A	With single use fitting block, 3-port normally closed (NC)																					
		FJ6B	With single use fitting block, 3-port normally open (NO)																					
		FMA	With female thread block, 3-port normally closed (NC)																					
		FMB	With female thread block, 3-port normally open (NO)																					
		FMH	With female thread block																					
		FMAH	With female thread block, 3-port normally closed (NC)																					
		FMBH	With female thread block, 3-port normally open (NO)																					
		Manifold fitting specification <sup>Note5</sup> (Manifold side outlet port)	J5	With single use fitting block																				
J6	With single use fitting block																							
M	With female thread block																							
J5A	With single use fitting block, 3-port normally closed (NC)																							
J5B	With single use fitting block, 3-port normally open (NO)																							
J6A	With single use fitting block, 3-port normally closed (NC)																							
J6B	With single use fitting block, 3-port normally open (NO)																							
MA	With female thread block, 3-port normally closed (NC)																							
MB	With female thread block, 3-port normally open (NO)																							
MH	With female thread block																							
E2 <sup>Note12</sup>	Back pressure prevention valve																							
PPM	Individual air supply spacer (with M5 female thread for F10)																							
PP6	Individual air supply spacer (with φ 6 fitting for F15)																							
PP8	Individual air supply spacer (with φ 8 fitting for F15)																							
PRM	Individual exhaust spacer (with M5 female thread for F10)																							
PR6	Individual exhaust spacer (with φ 6 fitting for F15)																							
PR8	Individual exhaust spacer (with φ 8 fitting for F15)																							
Port isolator (-SP) For 1(P) port <sup>Note8</sup>																								
Port isolator (-SR) For 3(R2), 5(R1) ports <sup>Note8</sup>																								
Port isolator (-SA) For 1(P), 3(R2), 5(R1) ports <sup>Note8</sup>																								

- Notes: 1. Cannot be mounted on the external pilot manifold.  
 2. Cannot be mounted on the internal pilot manifold.  
 3. To designate a manual override lever, enter ○ in the manual override boxes of the designated stations in the above table.  
 4. When the manifold outlet specifications are "Blank", select fitting specification for each station, and enter ○ in the valve outlet type boxes of the above table. The 3-port specifications are only available in valve specifications T0, T1, and T2.  
 5. When the manifold outlet specifications are L (with selectable fitting), select manifold fitting specification for each station, and enter ○ in the manifold fitting specification boxes of the above table. The 3-port specifications are only available in valve specifications T0, T1, and T2.  
 6. When mounting the individual air supply or exhaust spacer, enter ○ in the spacer boxes of the designated stations in the above table.  
 7. To designate a port isolator, enter ○ in one port isolator box of the designated stations in the above table.  
 8. Port isolators can be installed only when piping blocks are mounted on both sides. In addition, only 1 port isolator can be mounted in 1 manifold for -SA, or 1 each port isolator for -SP and -SR for a total of 2 locations. When shipping, the designated port isolators are installed between the designated station and the station to its immediate left (the next smaller stn. No.).  
 9. Not available in low-current type.  
 10. AC100V and AC120V can only be used when wiring specifications are -D250□, -D251□ (D-sub connector), or -T200 (terminal). In addition, not available in low-current type and tandem 3-port valves.  
 11. Not available in external pilot type.  
 12. When mounting the back pressure prevention valve, enter ○ in the back pressure prevention valve boxes of the designated stations in the above table. Not available with the individual exhaust spacer.  
 13. Can be selected only when the manifold type is P.  
 14. Can be selected only when the manifold type is PH.

Quantity	set	Delivery
----------	-----	----------



# F10, F15 Series

## Serial Transmission Compatible Manifold

# Specifications Confirmation Form 2/2

※For specifying the valve and block-off plate to be mounted at each station, enter ○ in each applicable box below.

Mounting valve, block-off plate		Station	1	2	3	4	5	6	7	8	9	10	11	12	13	14	15	16	17	18	19	20	
Mounting valve models	<input type="checkbox"/> <b>T0</b>	2-position, for single solenoid only																					
	<input type="checkbox"/> <b>T1</b>	2-position, single solenoid specification																					
	<input type="checkbox"/> <b>T2</b>	2-position, double solenoid specification																					
	<input type="checkbox"/> <b>T3</b>	3-position, closed center																					
	<input type="checkbox"/> <b>T4</b>	3-position, exhaust center																					
	<input type="checkbox"/> <b>T5</b>	3-position, pressure center																					
	<input type="checkbox"/> <b>TA</b> <sup>Note9</sup>	Tandem 3-port (NC and NC)																					
	<input type="checkbox"/> <b>TB</b> <sup>Note9</sup>	Tandem 3-port (NO and NO)																					
	<input type="checkbox"/> <b>TC</b> <sup>Note9</sup>	Tandem 3-port (NC and NO)																					
	<input type="checkbox"/> <b>LT0</b>	(Low current type) 2-position, for single solenoid only																					
	<input type="checkbox"/> <b>LT1</b>	(Low current type) 2-position, single solenoid specification																					
	<input type="checkbox"/> <b>LT2</b>	(Low current type) 2-position, double solenoid specification																					
	<input type="checkbox"/> <b>LT3</b>	(Low current type) 3-position, closed center																					
	<input type="checkbox"/> <b>LT4</b>	(Low current type) 3-position, exhaust center																					
	<input type="checkbox"/> <b>LT5</b>	(Low current type) 3-position, pressure center																					
	<input type="checkbox"/> <b>LTA</b>	(Low current type) Tandem 3-port (NC and NC)																					
	<input type="checkbox"/> <b>LTB</b>	(Low current type) Tandem 3-port (NO and NO)																					
	<input type="checkbox"/> <b>LTC</b>	(Low current type) Tandem 3-port (NC and NO)																					
	<input type="checkbox"/> <b>BPP</b>	Block-off plate																					
	Manual override (-R) Manual override lever <sup>Note3</sup>																						
	Valve outlet type <sup>Note4</sup>	<b>FJ</b>	With dual use fitting block																				
		<b>FJ5</b>	With single use fitting block																				
		<b>FJ6</b>	With single use fitting block																				
		<b>FM</b>	With female thread block																				
		<b>FJ5A</b>	With single use fitting block, 3-port normally closed (NC)																				
		<b>FJ5B</b>	With single use fitting block, 3-port normally open (NO)																				
		<b>FJ6A</b>	With single use fitting block, 3-port normally closed (NC)																				
		<b>FJ6B</b>	With single use fitting block, 3-port normally open (NO)																				
		<b>FMA</b>	With female thread block, 3-port normally closed (NC)																				
		<b>FMB</b>	With female thread block, 3-port normally open (NO)																				
		<b>FMH</b>	With female thread block																				
		<b>FMAH</b>	With female thread block, 3-port normally closed (NC)																				
		<b>FMBH</b>	With female thread block, 3-port normally open (NO)																				
		Manifold fitting specification <sup>Note5</sup> (Manifold side outlet port)	<b>J5</b>	With single use fitting block																			
	<b>J6</b>		With single use fitting block																				
	<b>M</b>		With female thread block																				
	<b>J5A</b>		With single use fitting block, 3-port normally closed (NC)																				
<b>J5B</b>	With single use fitting block, 3-port normally open (NO)																						
<b>J6A</b>	With single use fitting block, 3-port normally closed (NC)																						
<b>J6B</b>	With single use fitting block, 3-port normally open (NO)																						
<b>MA</b>	With female thread block, 3-port normally closed (NC)																						
<b>MB</b>	With female thread block, 3-port normally open (NO)																						
<b>MH</b>	With female thread block																						
<b>MAH</b>	With female thread block, 3-port normally closed (NC)																						
<b>MBH</b>	With female thread block, 3-port normally open (NO)																						
<b>E2</b> <sup>Note10</sup>	Back pressure prevention valve																						
<b>PPM</b>	Individual air supply spacer (with M5 female thread for F10)																						
<b>PP6</b>	Individual air supply spacer (with φ 6 fitting for F15)																						
<b>PP8</b>	Individual air supply spacer (with φ 8 fitting for F15)																						
<b>PRM</b>	Individual exhaust spacer (with M5 female thread for F10)																						
<b>PR6</b>	Individual exhaust spacer (with φ 6 fitting for F15)																						
<b>PR8</b>	Individual exhaust spacer (with φ 8 fitting for F15)																						
Port isolator (-SP) For 1(P) port <sup>Note8</sup>																							
Port isolator (-SR) For 3(R2), 5(R1) ports <sup>Note8</sup>																							
Port isolator (-SA) For 1(P), 3(R2), 5(R1) ports <sup>Note8</sup>																							

- Notes: 1. Cannot be mounted on the external pilot manifold.  
 2. Cannot be mounted on the internal pilot manifold.  
 3. To designate a manual override lever, enter ○ in the manual override boxes of the designated stations in the above table.  
 4. When the manifold outlet specifications are "Blank", select fitting specification for each station, and enter ○ in the valve outlet type boxes of the above table. The 3-port specifications are only available in valve specifications **T0**, **T1**, and **T2**.  
 5. When the manifold outlet specifications are **L** (with selectable fitting), select manifold fitting specification for each station, and enter ○ in the manifold fitting specification boxes of the above table. The 3-port specifications are only available in valve specifications **T0**, **T1**, and **T2**.  
 6. When mounting the individual air supply or exhaust spacer, enter ○ in the spacer boxes of the designated stations in the above table.  
 7. To designate a port isolator, enter ○ in one port isolator box of the designated stations in the above table.  
 8. Port isolators can be installed only when piping blocks are installed on both sides. In addition, only 1 port isolator can be mounted in 1 manifold for **-SA**, or 1 each port isolator for **-SP** and **-SR** for a total of 2 locations. When shipping, the designated port isolators are installed between the designated station and the station to its immediate left (the next smaller stn. No.).  
 9. Not available in external pilot type.  
 10. When mounting the back pressure prevention valve, enter ○ in the back pressure prevention valve boxes of the designated stations in the above table. Not available with the individual exhaust spacer.

Quantity	set	Delivery
----------	-----	----------







# F18 Series

## Split Manifold Non-Plug-in Type

# Specifications Confirmation Form 2/2

※For specifying the valve and block-off plate to be mounted at each station, enter ○ in each applicable box below.

Mounting valve, block-off plate		Station	1	2	3	4	5	6	7	8	9	10	11	12	13	14	15	16	17	18	19	20	
Mounting valve models	<b>F18T0</b>	2-position, for single solenoid only																					
	<b>F18T1</b>	2-position, single solenoid specification																					
	<b>F18T2</b>	2-position, double solenoid specification																					
	<b>F18T3</b>	3-position, closed center																					
	<b>F18T4</b>	3-position, exhaust center																					
	<b>F18T5</b>	3-position, pressure center																					
	<b>F18BPN</b>	Block-off plate																					
	Manual override (-R) Manual override lever <sup>Note3</sup>																						
	Valve outlet type <sup>Note4</sup>	<b>FJ</b>	With dual use fitting block																				
		<b>FJ5</b>	With single use fitting block																				
		<b>FJ6</b>	With single use fitting block																				
		<b>FM</b>	With female thread block																				
		<b>FMH</b>	With female thread block																				
	Manifold fitting specification <sup>Note5</sup> (Manifold side outlet port)	<b>J5</b>	With single use fitting block																				
		<b>J6</b>	With single use fitting block																				
		<b>MH</b>	With female thread block																				
	<b>NP8</b>	Individual air supply spacer (with φ 8 fitting)																					
<b>NP0</b>	Individual air supply spacer (with φ 10 fitting)																						
<b>NR8</b>	Individual exhaust spacer (with φ 8 fitting)																						
<b>NR0</b>	Individual exhaust spacer (with φ 10 fitting)																						
Port isolator (-SP) For 1(P) port <sup>Note8</sup>																							
Port isolator (-SR) For 3(R2), 5(R1) ports <sup>Note8</sup>																							
Port isolator (-SA) For 1(P), 3(R2), 5(R1) ports <sup>Note8</sup>																							

- Notes: 1. Cannot be mounted on the external pilot manifold.  
 2. Cannot be mounted on the internal pilot manifold.  
 3. To designate a manual override lever, enter ○ in the manual override boxes of the designated stations in the above table.  
 4. When the manifold outlet specifications are "Blank", select fitting specification for each station, and enter ○ in the valve outlet type boxes of the above table.  
 5. When the manifold outlet specifications are L (with selectable fitting), select manifold fitting specification for each station, and enter ○ in the manifold fitting specification boxes of the above table.  
 6. When mounting the individual air supply or exhaust spacer, enter ○ in the one spacer box of the designated stations in the above table.  
 7. To designate a port isolator box of the designated station, enter ○ in the port isolator box in the above table.  
 8. Port isolators can be installed only when piping blocks are mounted on both sides. In addition, only 1 port isolator can be mounted in 1 manifold for -SA, or 1 each port isolator for -SP and -SR for a total of 2 locations.  
 When shipping, the designated port isolators are mounted between the designated station and the station to its immediate left (the next smaller stn. No.).

Quantity	set	Delivery
----------	-----	----------

# F18 Series

Split Manifold Plug-in Type

## Specifications Confirmation Form 1/2

Company name	
Contact person	
Order No.	

• Fill in selections inside the thick-lined boxes.

Manifold model

**F 18 M**  **P**  **PH**   -  -  -  -

Manifold model

**Pilot specification**  
**Blank**: Internal pilot manifold  
**G** : External pilot manifold

**Manifold outlet specification**  
**J** : With dual use fitting blocks  
**M** : With female thread blocks  
**L** : With selectable fitting blocks  
**Blank**: With plates (direct piping type)

**Valve units**  
 2 to  <sup>Note</sup>

Note: For the maximum number of units, check the table for maximum number of valve units by wiring specification on page 84.

**Piping block specification (air supply and exhaust)**  
 Can be selected only when the manifold type is **P** (metric).  
**JR** : With dual use fitting, right-side mounting  
**JL** : With dual use fitting, left-side mounting  
**JD** : With dual use fitting, both-side mounting  
**MR** : With female thread, right-side mounting  
**ML** : With female thread, left-side mounting  
**MD** : With female thread, both-side mounting

Can be selected only when the manifold type is **PH** (imperial).  
**MRH** : With female thread, right-side mounting  
**MLH** : With female thread, left-side mounting  
**MDH** : With female thread, both-side mounting

**Wiring position (wiring block)**  
**Blank**: Left-side mounting  
**R** : Right-side mounting

**Wiring connection specification**  
**Blank**: Packed wiring  
**W** : Double wiring

**Wiring specification**  
**F100** : Flat cable connector 10-pin  
**F101** : Flat cable connector 10-pin  
**F200** : Flat cable connector 20-pin  
**F201** : Flat cable connector 20-pin  
**F260** : Flat cable connector 26-pin

(M2.6 mounting screws)  
**D250** : D-sub connector 25-pin <sup>Note10</sup>  
**D251** : D-sub connector 25-pin <sup>Note10</sup>  
 (4-40UNC mounting screws)  
**D250U** : D-sub connector 25-pin <sup>Note11</sup>  
**D251U** : D-sub connector 25-pin <sup>Note11</sup>  
**D370NU** : D-sub connector 37-pin without power terminal <sup>Note11</sup>

**T200** : Terminal block (19 terminals, M3 screws)

Mounting valve model

**stn.**  **F18T**  **Valve specification**  -  <sup>Note3</sup> -  <sup>Note4</sup> **A1**  -  <sup>Note5</sup> -  <sup>Note6</sup> -  <sup>Note7</sup>

Mounting valve model

**Operation type**  
**Blank**: Internal pilot type <sup>Note1</sup>  
**G** : External pilot type <sup>Note2</sup>

**Manual override**  
**Blank**: Manual override button  
**R** : Manual override lever <sup>Note3</sup>

**Valve outlet type**  
**A1**: With plate (When the manifold outlet specification are **J**, **M**, or **L**, the valve type should be **A1**.)

Can be selected only when the manifold type is **P** and manifold outlet specification is "**Blank**" (metric).  
**FJ**: With dual use  $\phi 8$  and  $\phi 10$  fitting block <sup>Note4</sup>  
**FJ5**: With single use  $\phi 8$  fitting block <sup>Note4</sup>  
**FJ6**: With single use  $\phi 10$  fitting block <sup>Note4</sup>  
**FM**: With Rc1/4 female thread block <sup>Note4</sup>

Can be selected only when the manifold type is **PH** and manifold outlet specification is "**Blank**" (imperial).  
**FMH**: With NPT1/4 female thread block

**Manifold fitting specifications** <sup>Note5</sup>  
 Can be selected only when manifold type is **P** and manifold outlet specification is **L** (with selectable fitting blocks (metric))  
**J5** : Manifold side outlet port with single use  $\phi 8$  fitting block  
**J6** : Manifold side outlet port with single use  $\phi 10$  fitting block

Can be selected only when manifold type is **PH** and manifold outlet specification is **L** (with selectable fitting blocks (imperial))  
**MH**: with NPT1/4 female thread block

**Voltage**  
 DC12V  
 DC24V  
 AC100V <sup>Note9</sup>  
 AC120V <sup>Note9</sup>

**Port isolator**  
**Blank**: No port isolator  
**SP** : For 1(P) port  
**SR** : For 3(R2), 5(R1) ports  
**SA** : For 1(P), 3(R2), 5(R1) ports

**Individual air supply and exhaust apacer** <sup>Note6</sup>  
**Blank**: No spacer  
**PP8** : Individual air supply spacer (with  $\phi 8$  fitting)  
**PP0** : Individual air supply spacer (with  $\phi 10$  fitting)  
**PR8** : Individual exhaust spacer (with  $\phi 8$  fitting)  
**PR0** : Individual exhaust spacer (with  $\phi 10$  fitting)

Enter ○ in each designated station in tables on the next page.

# F18 Series

## Split Manifold Plug-in Type

# Specifications Confirmation Form 2/2

※For specifying the valve and block-off plate to be mounted at each station, enter ○ in each applicable box below.

Mounting valve, block-off plate		Station	1	2	3	4	5	6	7	8	9	10	11	12	13	14	15	16	17	18	19	20	
Mounting valve models	<b>F18T0</b>	2-position, for single solenoid only																					
	<b>F18T1</b>	2-position, single solenoid specification																					
	<b>F18T2</b>	2-position, double solenoid specification																					
	<b>F18T3</b>	3-position, closed center																					
	<b>F18T4</b>	3-position, exhaust center																					
	<b>F18T5</b>	3-position, pressure center																					
	<b>F18BPP</b>	Block-off plate																					
	Manual override (-R) Manual override lever <sup>Note3</sup>																						
	Valve outlet type <sup>Note4</sup>	<b>FJ</b>	With dual use fitting block																				
		<b>FJ5</b>	With single use fitting block																				
		<b>FJ6</b>	With single use fitting block																				
		<b>FM</b>	With female thread block																				
		<b>FMH</b>	With female thread block																				
	Manifold fitting specification <sup>Note5</sup> (Manifold side outlet port)	<b>J5</b>	With single use fitting block																				
		<b>J6</b>	With single use fitting block																				
		<b>MH</b>	With female thread block																				
	<b>PP8</b>	Individual air supply spacer (with φ 8 fitting)																					
	<b>PP0</b>	Individual air supply spacer (with φ 10 fitting)																					
	<b>PR8</b>	Individual exhaust spacer (with φ 8 fitting)																					
	<b>PR0</b>	Individual exhaust spacer (with φ 10 fitting)																					
Port isolator (-SP) For 1(P) port <sup>Note8</sup>																							
Port isolator (-SR) For 3(R2), 5(R1) ports <sup>Note8</sup>																							
Port isolator (-SA) For 1(P), 3(R2), 5(R1) ports <sup>Note8</sup>																							

- Notes: 1. Cannot be mounted on the external pilot manifold.  
 2. Cannot be mounted on the internal pilot manifold.  
 3. To designate a manual override lever, enter ○ in the manual override boxes of the designated stations in the above table.  
 4. When the manifold outlet specifications are "Blank", select fitting specification for each station, and enter ○ in the valve outlet type boxes of the above table.  
 5. When the manifold outlet specifications are L (with selectable fitting), select manifold fitting specification for each station, and enter ○ in the manifold fitting specification boxes of the above table.  
 6. When mounting the individual air supply or exhaust spacer, enter ○ in the spacer boxes of the designated stations in the above table.  
 7. To designate a port isolator box of the designated station, enter ○ in the port isolator box in the above table.  
 8. Port isolators can be installed only when piping blocks are mounted on both sides. In addition, only 1 port isolator can be mounted in 1 manifold for -SA, or 1 each port isolator for -SP and -SR for a total of 2 locations.  
 When shipping, the designated port isolators are installed between the designated station and the station to its immediate left (the next smaller stn. No.).  
 9. AC100V and AC120V can only be used when wiring specifications are -D250□, -D251□ (D-sub connector), or -T200 (terminal).  
 10. Can be selected only when the manifold type is P.  
 11. Can be selected only when the manifold type is PH.

Quantity	set	Delivery
----------	-----	----------

# F18 Series

## Serial Transmission Compatible Manifold Specifications Confirmation Form 1/2

Company name	
Contact person	
Order No.	

• Fill in selections inside the thick-lined boxes.

**Manifold model**

F 18 M  <sup>S</sup> SH   -  -  -  -

**Pilot specification**  
**Blank**: Internal pilot manifold  
**G** : External pilot manifold

**Manifold outlet specification**  
**J** : With dual use fitting blocks  
**M** : With female thread blocks  
**L** : With selectable fitting blocks  
**Blank**: With plates (direct piping type)

**Valve units**  
 2 to  <sup>Note</sup>

**Piping block specification (air supply and exhaust)**  
 Can be selected only when the manifold type is **S** (metric).  
**JR** : With dual use fitting, right-side mounting  
**JL** : With dual use fitting, left-side mounting  
**JD** : With dual use fitting, both-side mounting  
**MR** : With female thread, right-side mounting  
**ML** : With female thread, left-side mounting  
**MD** : With female thread, both-side mounting

Can be selected only when the manifold type is **SH** (imperial).  
**MRH** : With female thread, right-side mounting  
**MLH** : With female thread, left-side mounting  
**MDH** : With female thread, both-side mounting

**Wiring position (wiring block)**  
**Blank**: Left-side mounting  
**R** : Right-side mounting <sup>Note9</sup>

**Wiring connection specification**  
**Blank**: Packed wiring  
**W** : Double wiring

**Transmission block specification**  
**31** : For OMRON B7A Link Terminal (standard)  
**32** : For OMRON B7A Link Terminal (high speed)  
**A1** : For OMRON CompoBus/S (16 outputs)  
**B1** : For CC-Link (16 outputs)  
**H1** : For CompoNet (16 outputs) <sup>Note9</sup>

Note: For the maximum number of units, check the table for maximum number of valve units by wiring specification on page 88.

**Mounting valve model**

stn.  F18T  Valve specification  -  <sup>Note3</sup> -  <sup>Note4</sup> -  <sup>Note5</sup> -  <sup>Note6</sup> -  <sup>Note7</sup> DC24V

**Operation type**  
**Blank**: Internal pilot type <sup>Note1</sup>  
**G** : External pilot type <sup>Note2</sup>

**Manual override**  
**Blank**: Manual override button  
**R** : Manual override lever <sup>Note3</sup>

**Valve outlet type**  
**A1** : With plate (When manifold outlet specification are **J**, **M**, or **L**, the valve type should be **A1**.)

Can be selected only when the manifold type is **S** and the manifold outlet specification is "**Blank**".  
**FJ** : With dual use  $\phi 8$  and  $\phi 10$  fitting block <sup>Note4</sup>  
**FJ5** : With single use  $\phi 8$  fitting block <sup>Note4</sup>  
**FJ6** : With single use  $\phi 10$  fitting block <sup>Note4</sup>  
**FM** : With Rc1/4 female thread block <sup>Note4</sup>

Can be selected only when the manifold type is **SH** and the manifold outlet specification is "**Blank**".  
**FMH** : With NPT1/4 female thread block <sup>Note4</sup>

**Port isolator**  
**Blank**: No port isolator  
**SP** : For 1(P) port <sup>Note7</sup>  
**SR** : For 3(R2), 5(R1) ports <sup>Note7</sup>  
**SA** : For 1(P), 3(R2), 5(R1) ports <sup>Note7</sup>

**Individual air supply and exhaust apacer** <sup>Note6</sup>  
**Blank**: No spacer  
**PP8** : Individual air supply spacer (with  $\phi 8$  fitting)  
**PP0** : Individual air supply spacer (with  $\phi 10$  fitting)  
**PR8** : Individual exhaust spacer (with  $\phi 8$  fitting)  
**PRO** : Individual exhaust spacer (with  $\phi 10$  fitting)

**Manifold fitting specifications** <sup>Note5</sup>  
 Can be selected only when the manifold type is **S** and the manifold outlet specification is **L** (with selectable fitting blocks (metric))  
**J5** : Manifold side outlet port with single use  $\phi 8$  fitting block  
**J6** : Manifold side outlet port with single use  $\phi 10$  fitting block

Can be selected only when the manifold type is **SH** and the manifold outlet specification is **L** (with selectable fitting blocks (imperial))  
**MH** : with NPT1/4 female thread block

When manifold outlet specifications are **J**, **M**, or **L**.

Enter  in each designated station in tables on the next page.

# F18 Series

## Serial Transmission Compatible Manifold

# Specifications Confirmation Form 2/2

※For specifying the valve and block-off plate to be mounted at each station, enter ○ in each applicable box below.

Mounting valve, block-off plate		Station	1	2	3	4	5	6	7	8	9	10	11	12	13	14	15	16	17	18	19	20	
Mounting valve models	<b>F18T0</b>	2-position, for single solenoid only																					
	<b>F18T1</b>	2-position, single solenoid specification																					
	<b>F18T2</b>	2-position, double solenoid specification																					
	<b>F18T3</b>	3-position, closed center																					
	<b>F18T4</b>	3-position, exhaust center																					
	<b>F18T5</b>	3-position, pressure center																					
	<b>F18BPP</b>	Block-off plate																					
	Manual override (-R) Manual override lever <sup>Note3</sup>																						
	Valve outlet type <sup>Note4</sup>	<b>FJ</b>	With dual use fitting block																				
		<b>FJ5</b>	With single use fitting block																				
		<b>FJ6</b>	With single use fitting block																				
		<b>FM</b>	With female thread block																				
		<b>FMH</b>	With female thread block																				
	Manifold fitting specification <sup>Note5</sup> (Manifold side outlet port)	<b>J5</b>	With single use fitting block																				
		<b>J6</b>	With single use fitting block																				
		<b>MH</b>	With female thread block																				
	<b>PP8</b>	Individual air supply spacer (with φ 8 fitting)																					
	<b>PP0</b>	Individual air supply spacer (with φ 10 fitting)																					
	<b>PR8</b>	Individual exhaust spacer (with φ 8 fitting)																					
	<b>PR0</b>	Individual exhaust spacer (with φ 10 fitting)																					
Port isolator (-SP) For 1(P) port <sup>Note8</sup>																							
Port isolator (-SR) For 3(R2), 5(R1) ports <sup>Note8</sup>																							
Port isolator (-SA) For 1(P), 3(R2), 5(R1) ports <sup>Note8</sup>																							

- Notes: 1. Cannot be mounted on the external pilot manifold.  
 2. Cannot be mounted on the internal pilot manifold.  
 3. To designate a manual override lever, enter ○ in the manual override boxes of the designated stations in the above table.  
 4. When the manifold outlet specifications are "Blank", select fitting specification for each station, and enter ○ in the valve outlet type boxes of the above table.  
 5. When the manifold outlet specifications are L (with selectable fitting), select manifold fitting specification for each station, and enter ○ in the manifold fitting specification boxes of the above table.  
 6. When mounting the individual air supply or exhaust spacer, enter ○ in the spacer boxes of the designated stations in the above table.  
 7. To designate a port isolator box of the designated station, enter ○ in the port isolator box in the above table.  
 8. Port isolators can be installed only when piping blocks are mounted on both sides. In addition, only 1 port isolator can be mounted in 1 manifold for -SA, or 1 each port isolator for -SP and -SR for a total of 2 locations.  
 When shipping, the designated port isolators are mounted between the designated station and the station to its immediate left (the next smaller stn. No.).  
 9. The -H1 (for CompoNet (16 outputs)) transmission block is mountable on the left side only.

Quantity	set	Delivery
----------	-----	----------





# Limited Warranty

KOGANEI CORP. warrants its products to be free from defects in material and workmanship subject to the following provisions.

**Warranty Period** The warranty period is 180 days from the date of delivery.

**Koganei Responsibility** If a defect in material or workmanship is found during the warranty period, KOGANEI CORP. will replace any part proved defective under normal use free of charge and will provide the service necessary to replace such a part.

**Limitations**

- This warranty is in lieu of all other warranties, expressed or implied, and is limited to the original cost of the product and shall not include any transportation fee, the cost of installation or any liability for direct, indirect or consequential damage or delay resulting from the defects.

- KOGANEI CORP. shall in no way be liable or responsible for injuries or damage to persons or property arising out of the use or operation of the manufacturer's product.

- This warranty shall be void if the engineered safety devices are removed, made inoperative or not periodically checked for proper functioning.

- Any operation beyond the rated capacity, any improper use or application, or any improper installation of the product, or any substitution upon it with parts not furnished or approved by KOGANEI CORP., shall void this warranty.

- This warranty covers only such items supplied by KOGANEI CORP. The products of other manufacturers are covered only by such warranties made by those original manufacturers, even though such items may have been included as the components.

The specifications are subject to change without notice.

URL <http://www.koganei.co.jp>

E-mail: [overseas@koganei.co.jp](mailto:overseas@koganei.co.jp)



## KOGANEI CORPORATION

### OVERSEAS DEPARTMENT

3-11-28, Midori-cho, Koganei City, Tokyo 184-8533, Japan  
Tel: 81-42-383-7271 Fax: 81-42-383-7276

### KOGANEI INTERNATIONAL AMERICA, INC.

39300 Civic Center Dr., Suite 280, Fremont, CA 94538, U.S.A.  
Tel: 1-510-744-1626 Fax: 1-510-744-1676

### SHANGHAI KOGANEI INTERNATIONAL TRADING CORPORATION

Room 2606-2607, Tongda Venture Building No.1, Lane 600, Tianshan Road,  
Shanghai, 200051, China  
Tel: 86-21-6145-7313 Fax: 86-21-6145-7323

### TAIWAN KOGANEI TRADING CO., LTD.

Rm. 2, 13F., No88, Sec. 2, Zhongxiao E. Rd., Zhongzheng Dist., Taipei City 100,  
Taiwan (ROC)  
Tel: 886-2-2393-2717 Fax: 886-2-2393-2719

### KOGANEI KOREA CO., LTD.

6F-601, Tower Bldg., 1005, Yeongdeop-dong, Giheung-gu, Yongin-si, Gyeonggi-do,  
446-908, Korea  
Tel: 82-31-246-0414 Fax: 82-31-246-0415

### KOGANEI (THAILAND) CO., LTD.

3300/90, Tower B, Elephant Tower, 16th Fl., Phaholyothin Road, Chomphon,  
Chatuchak, Bangkok 10900, Thailand  
Tel: 66-2-937-4250 Fax: 66-2-937-4254

### KOGANEI ASIA PTE. LTD.

69 Ubi Road 1, #05-18 Oxley Bizhub, Singapore 408731  
Tel: 65-6293-4512 Fax: 65-6293-4513

<http://www.koganei.co.jp>



**NEW**  
Products

# F10 & F15 series solenoid valves

## IP specifications

**IP65 compliant** protective construction can be used in a wide range of operating environments!

### Ingress protection according to IEC 60529 standard

Electrical enclosures constructed to protect against intrusion of dust and water from the outside

International Protection Rating

## IP65

2nd digit indicates protection against the ingress of water<sup>Note</sup>

Jets of water by a nozzle against enclosure from any direction has no harmful effects.

1st digit indicates protection against solid foreign objects  
No ingress of dust.

Note: The device cannot be used underwater.

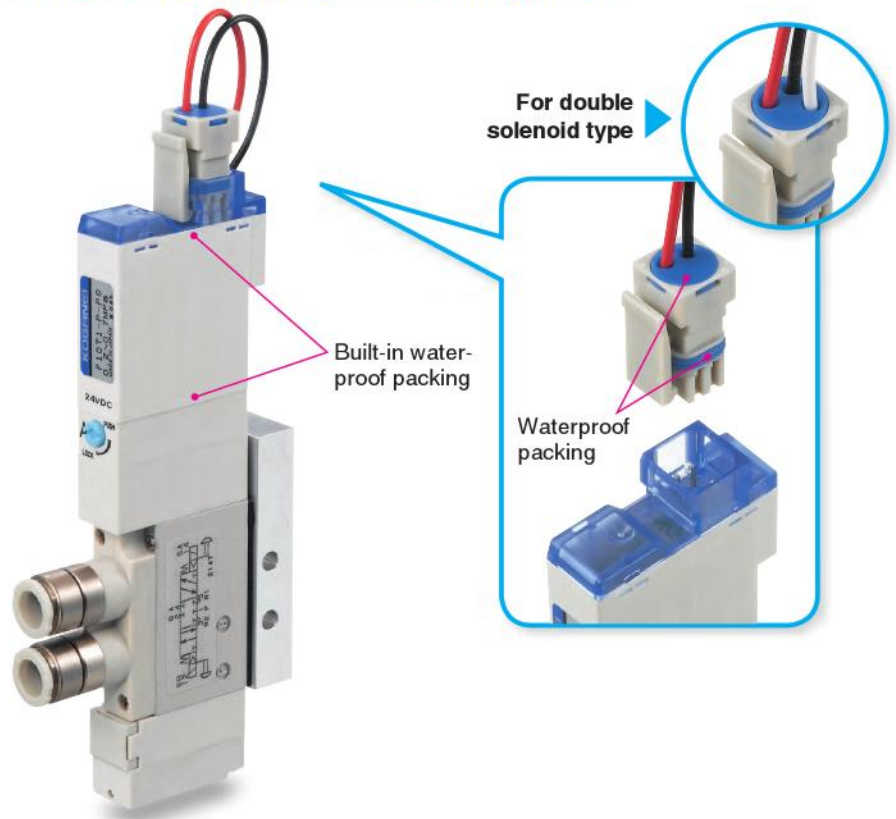

### Variations

Single valve unit



Monoblock manifold A type



Monoblock manifold F type



**CAUTION** Before use, be sure to read the "Safety Precautions" in the general personal catalog.

\*Consult the nearest Koganei sales office for use in locations or environments subject to liquids other than water, such as organic solvents, cutting oil, or chemicals.

# F10, F15 Series Single Valve Unit Order Codes

## Valve size

### F10

10 mm [0.394 in.] width  
Standard type

### F10L

10 mm [0.394 in.] width  
Low-current type

### F15

15 mm [0.591 in.] width  
Standard type

### F15L

15 mm [0.591 in.] width  
Low-current type

## Valve outlet type

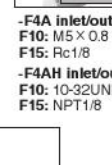
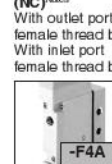
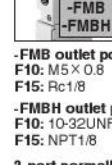
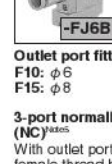
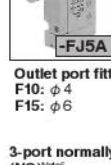
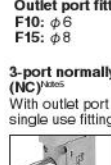
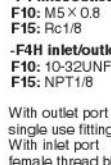
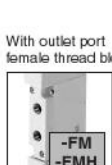
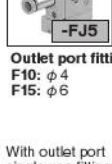
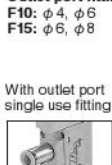
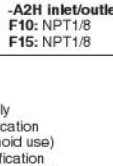
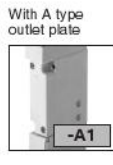

## 3-port normally open (NO)<sup>Note5</sup>

With outlet port female thread block  
With inlet port female thread block

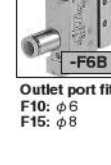
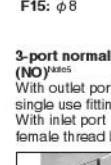
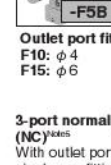
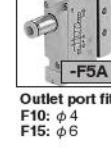
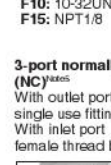
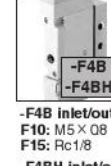

## Wiring specification

L type plug connector  
Without connector

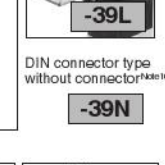
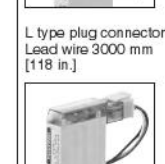
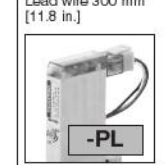
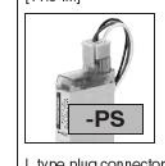
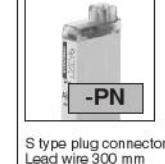
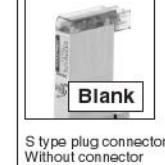

## Valve specification

- T0 : 2-position, for single solenoid only
- T1 : 2-position single solenoid specification (for both single and double solenoid use)
- T2 : 2-position double solenoid specification (for both single and double solenoid use)
- T3 : 3-position closed center
- T4 : 3-position exhaust center<sup>Note3</sup>
- T5 : 3-position pressure center<sup>Note3</sup>
- TA : Tandem 3-port (NC and NC)<sup>Note4</sup>
- TB : Tandem 3-port (NO and NO)<sup>Note4</sup>
- TC : Tandem 3-port (NC and NO)<sup>Note4</sup>

## Operation type

### Blank

Internal pilot type

### G

External pilot type<sup>Note6</sup>  
(for positive pressure)

### V

External pilot type<sup>Note6</sup>  
(for vacuum)<sup>Note7</sup>  
※ This is a vacuum valve.

Note: When using as a single unit, select -A2, -A2H (A type with sub-base) for the valve outlet type. Without a sub-base, piping for the external pilot is not possible.

## Manual override

Manual override button

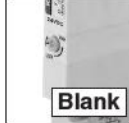

No protrusion with DIN connector

Manual override lever<sup>Note8</sup>



Protruding locking type<sup>Note9</sup>



Valve size	Valve specification	Operation type	IP65 specification	Manual override	Valve outlet type	Wiring specification	Voltage
F10	T0 T1	Blank	-P	Blank	Blank <sup>Note2</sup>	Blank	DC24V
F10L	T2 T3				-A1 <sup>Note2</sup>	-PN <sup>Note7</sup>	DC12V <sup>Note7</sup>
F15	T4 <sup>Note3</sup> T5 <sup>Note3</sup> TA <sup>Note4</sup> TB <sup>Note4</sup> TC <sup>Note4</sup>	G V		-R <sup>Note1</sup> -83 <sup>Note9</sup>	-A2 <sup>Note3</sup> -A2H <sup>Note3</sup> -FJ <sup>Note2,3</sup> -FJ5 <sup>Note2,3</sup> -FJ6 <sup>Note2,3</sup> -F4 <sup>Note4</sup> -F4H <sup>Note4</sup> -F5 <sup>Note4</sup> -F6 <sup>Note4</sup> -F4A <sup>Note4</sup> -F4AH <sup>Note4</sup> -F5A <sup>Note4</sup> -F5B <sup>Note4</sup> -F6A <sup>Note4</sup> -F6B <sup>Note4</sup>	-PL <sup>Note8</sup> -PS3 <sup>Note8</sup> -PL3 <sup>Note8</sup> -39L <sup>Note10</sup> -39N <sup>Note10</sup>	AC100V <sup>Note8, 11</sup> AC120V <sup>Note8</sup> AC240V <sup>Note8, 9</sup>

- Notes: 1. When the valve specification is T1 or T2, the manual override lever is placed only on the A side. This is not available with -39□.
2. Two manifold mounting screws are included.
3. Not available in the vacuum valves.
4. Not available in external pilot type and vacuum valves.
5. Only for valve specification T0, T1, and T2.
6. Thread size for the inlet port female thread block is F10: M5 × 0.8, F15: Rc1/8.

7. Not available in low-current type.
8. Not available in low-current type and tandem 3-port valves.
9. Only for wiring specification -39□.
10. Only for F15 series and not available for valve specification T1, TA, TB, and TC. In addition, the valve is used only as a double solenoid for T2.
11. Not available with DIN connectors.

Remark: Negative common specifications are also available as made to order products (add -129W to the end of order code). For details, consult us.

Manifolds on which IP specification valves can be mounted are the A type and F type monoblock manifold, and the split manifold non-plug-in type in the F10 and F15 series. For the A type and the split manifold non-plug-in type, you must put a -P after the operation type of each valve. For the F type, you must put a -P after the valve specifications of each valve. They can be combined only with IP specification valves. See the F series solenoid valve catalog for details about the manifold order codes.

# F10, F15 Series Single Valve Unit Additional Parts Order Codes

## ● For internal pilot

F  Z -

**Valve size**  
 10: 10 mm  
 [0.394 in.] width  
 15: 15 mm  
 [0.591 in.] width

**Parts content**  
**21** : Mounting bracket (mounting bracket, 2 mounting screws)  
**25** : Sub-base Rc1/8 (sub-base body, gasket, exhaust valve)<sup>Note1</sup>  
**25H** : Sub-base NPT1/8 (sub-base body, gasket, exhaust valve)<sup>Note1</sup>  
**P** : Plate (plate, gasket, 2 mounting screws)  
**J** : Dual use fitting block (fitting block, gasket, 2 mounting screws)  
**J5** : Single use fitting block **F10**: φ 4, **F15**: φ 6 (fitting block, gasket, 2 mounting screws)  
**J6** : Single use fitting block **F10**: φ 6, **F15**: φ 8 (fitting block, gasket, 2 mounting screws)  
**J5A** : Single use fitting block for 3-port **F10**: φ 4, **F15**: φ 6 (fitting block, gasket, 2 mounting screws)<sup>Note2</sup>  
**J6A** : Single use fitting block for 3-port **F10**: φ 6, **F15**: φ 8 (fitting block, gasket, 2 mounting screws)<sup>Note2</sup>  
**M** : Female thread block **F10**: M5 × 0.8 **F15**: Rc1/8 (female thread block, gasket, 2 mounting screws)  
**MH** : Female thread block **F10**: 10-32UNF **F15**: NPT1/8 (female thread block, gasket, 2 mounting screws)  
**MA** : Female thread block for 3-port **F10**: M5 × 0.8 **F15**: Rc1/8 (female thread block, gasket, 2 mounting screws)<sup>Note3</sup>  
**MAH** : Female thread block for 3-port **F10**: 10-32UNF **F15**: NPT1/8 (female thread block, gasket, 2 mounting screws)<sup>Note3</sup>  
**MPP** : P port female thread block **F10**: M5 × 0.8 **F15**: Rc1/8 (P port female thread block, gasket)<sup>Note1</sup>  
**MPPH** : P port female thread block **F10**: 10-32UNF **F15**: NPT1/8 (P port female thread block, gasket)<sup>Note1</sup>  
**GS1** : Gasket (gasket, exhaust valve)<sup>Note2</sup>

Notes: 1. Valve mounting screws are not included.  
 2. Caution should be exercised as this gasket is different from the **GS2** gasket for the split-type manifolds.  
 3. Common to both normally closed (NC) and normally open (NO) types. Select the mounting direction by application requirements.

## ● For external pilot

F  Z -

**Valve size**  
 10: 10 mm  
 [0.394 in.] width  
 15: 15 mm  
 [0.591 in.] width

**Parts content**  
**P** : Plate (plate, gasket, 2 mounting screws)  
**J** : Dual use fitting block (fitting block, gasket, 2 mounting screws)  
**J5** : Single use fitting block **F10**: φ 4, **F15**: φ 6 (fitting block, gasket, 2 mounting screws)  
**J6** : Single use fitting block **F10**: φ 6, **F15**: φ 8 (fitting block, gasket, 2 mounting screws)  
**J5A** : Single use fitting block for 3-port **F10**: φ 4, **F15**: φ 6 (fitting block, gasket, 2 mounting screws)<sup>Note1</sup>  
**J6A** : Single use fitting block for 3-port **F10**: φ 6, **F15**: φ 8 (fitting block, gasket, 2 mounting screws)<sup>Note1</sup>  
**M** : Female thread block **F10**: M5 × 0.8 **F15**: Rc1/8 (female thread block, gasket, 2 mounting screws)  
**MH** : Female thread block **F10**: 10-32UNF **F15**: NPT1/8 (female thread block, gasket, 2 mounting screws)  
**MA** : Female thread block for 3-port **F10**: M5 × 0.8 **F15**: Rc1/8 (female thread block, gasket, 2 mounting screws)<sup>Note1</sup>  
**MAH** : Female thread block for 3-port **F10**: 10-32UNF **F15**: NPT1/8 (female thread block, gasket, 2 mounting screws)<sup>Note1</sup>  
**GS1** : Gasket (gasket, exhaust valve)<sup>Note2</sup>

Notes: 1. Common to both normally closed (NC) and normally open (NO) types. Select the mounting direction by application requirements.  
 2. Caution should be exercised as this gasket is different from the **GS2** gasket for the split type manifolds.

## Sub-base for external pilot

F  ZG - 25

**Valve size**  
 10: 10 mm [0.394 in.] width  
 15: 15 mm [0.591 in.] width  
 Sub-base Rc1/8

F  ZG - 25H

**Valve size**  
 10: 10 mm [0.394 in.] width  
 15: 15 mm [0.591 in.] width  
 Sub-base NPT1/8

## Connector-related order codes

JAZ - P -  (For Double solenoid valve only)

**Valve specification**  
 For T2, T3, T4,  
 T5,  
 TA, TB, TC

**Connector specification**  
**CP** : Connector, lead wire length 300 mm [11.8 in.]  
**CP3** : Connector, lead wire length 3000 mm [118 in.]  
**PA** : Positive common A type, lead wire length 300 mm [11.8 in.] \*  
**PA3** : Positive common A type, lead wire length 3000 mm [118 in.] \*  
**PB** : Positive common B type, lead wire length 300 mm [11.8 in.] \*  
**PB3** : Positive common B type, lead wire length 3000 mm [118 in.] \*  
**PC** : Positive common C type, lead wire length 300 mm [11.8 in.] \*  
**PC3** : Positive common C type, lead wire length 3000 mm [118 in.] \*

The \* (asterisk) indicates a common connector assembly.

JAZ0 - P -  (For Single solenoid valve only)

**Valve specification**  
 For T0, T1

**Connector specification**  
**CP** : Connector, lead wire length 300 mm [11.8 in.]  
**CP3** : Connector, lead wire length 3000 mm [118 in.]  
**PA** : Positive common A type, lead wire length 300 mm [11.8 in.] \*  
**PA3** : Positive common A type, lead wire length 3000 mm [118 in.] \*  
**PB** : Positive common B type, lead wire length 300 mm [11.8 in.] \*  
**PB3** : Positive common B type, lead wire length 3000 mm [118 in.] \*  
**PC** : Positive common C type, lead wire length 300 mm [11.8 in.] \*  
**PC3** : Positive common C type, lead wire length 3000 mm [118 in.] \*

The \* (asterisk) indicates a common connector assembly.

- Note 1: If the valve specification is T1, select the single solenoid type JAZ0-P- only.  
 2: To switch between single and double solenoid (T1/T2), purchase and use the connector specified for the single or double solenoid (the single and double solenoid have a different number of holes in the packing for the lead wires).  
 3: The JAZ0-P- have no white lead wire.  
 4: The connectors must be disassembled to add valves to the common connector assemblies. Consult the nearest Koganei sales office.  
 5: Consult the nearest Koganei sales office for use in locations or environments subject to liquids other than water, such as organic solvents, cutting oil, or chemicals.  
 6: Consult the nearest Koganei sales office about how to replace the waterproof packing.

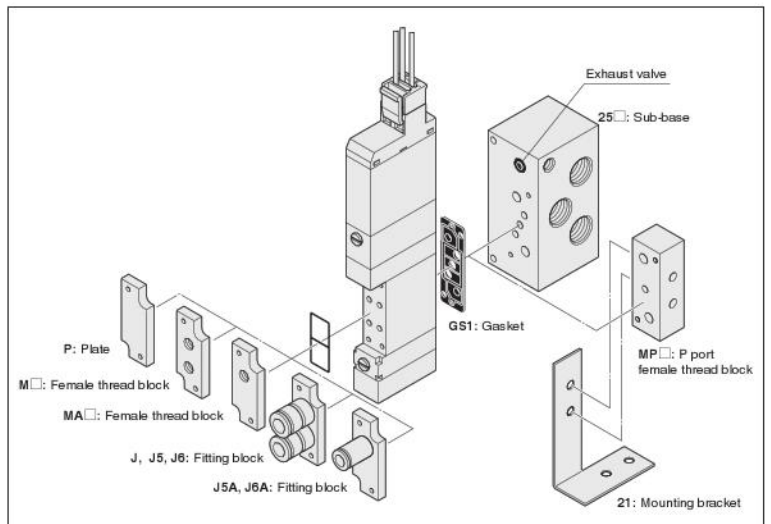

**F10T** Valve specifications **Operation type** -P-A2-PS

**F10T** Valve specifications **Operation type** -P-A2H-PS

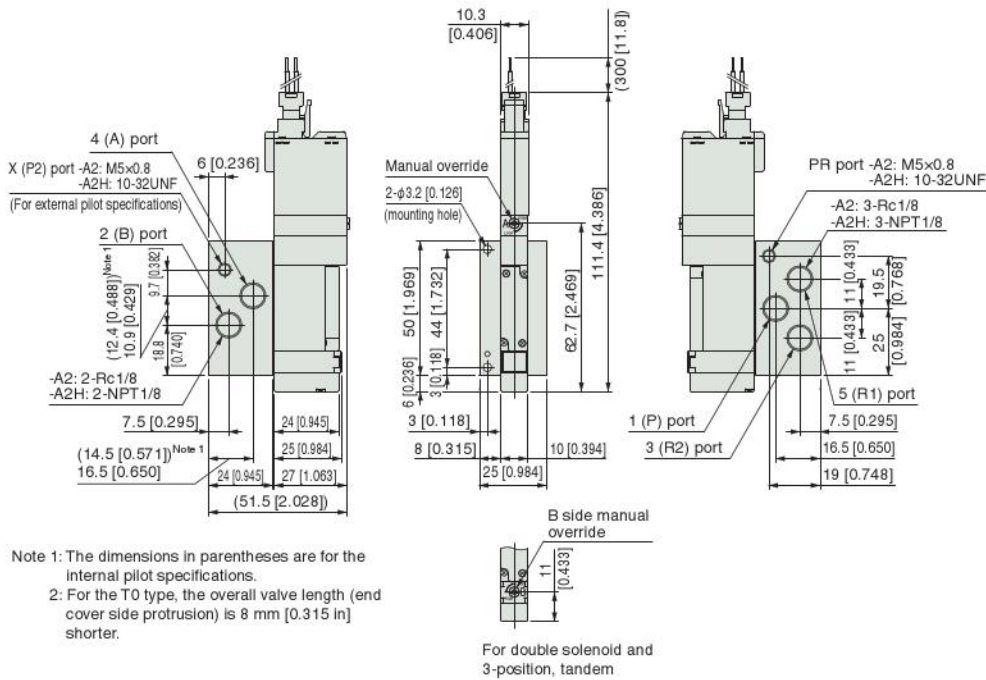

● L-type plug connector: -PL

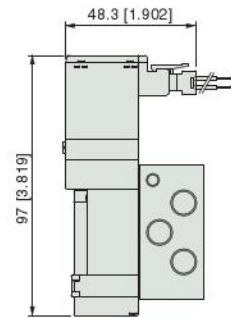

**F15T** Valve specifications **Operation type** -P-A2-PS

**F15T** Valve specifications **Operation type** -P-A2H-PS

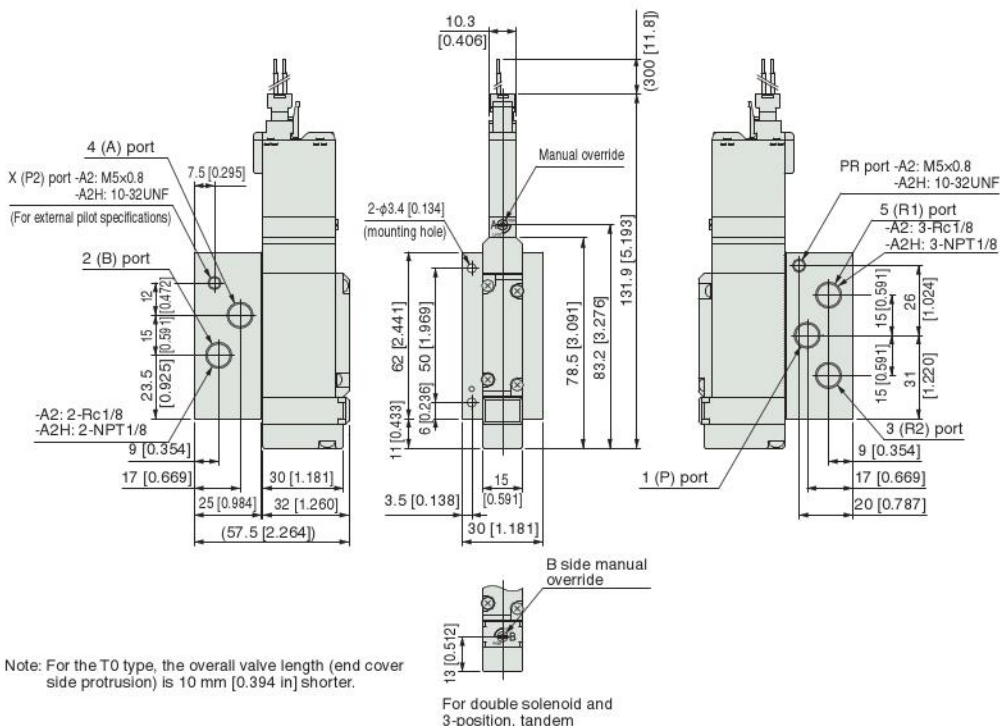

● L-type plug connector: -PL

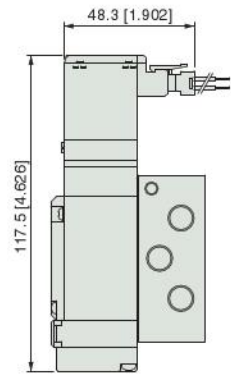

URL <http://www.koganei.co.jp>

E-mail: [overseas@koganei.co.jp](mailto:overseas@koganei.co.jp)



**KOGANEI CORPORATION**

OVERSEAS DEPARTMENT  
 3-11-28, Midori-cho, Koganei City, Tokyo 184-8533, Japan  
 Tel: 81-42-383-7271 Fax: 81-42-383-7276

KOGANEI INTERNATIONAL AMERICA, INC.  
 39300 Civic Center Dr., Suite 280, Fremont, CA 94538, U.S.A.  
 Tel: 1-510-744-1626 Fax: 1-510-744-1676

SHANGHAI KOGANEI INTERNATIONAL TRADING CORPORATION  
 Room 2606-2607, Tongda Venture Building No. 1, Lane 600, Tianshan Road, Shanghai, 200051, China  
 Tel: 86-21-6145-7313 Fax: 86-21-6145-7323

TAIWAN KOGANEI TRADING CO., LTD.  
 Rm. 2, 13F., No88, Sec. 2, Zhongxiao E. Rd., Zhongzheng Dist., Taipei City 100, Taiwan (ROC)  
 Tel: 886-2-2393-2717 Fax: 886-2-2393-2719

KOGANEI KOREA CO., LTD.  
 6F-601, Tower Bldg., 1005, Yeongdeong-dong, Giheung-gu, Yongin-si, Gyeonggi-do, 446-908, Korea  
 Tel: 82-31-246-0414 Fax: 82-31-246-0415

KOGANEI (THAILAND) CO., LTD.  
 3300/90, Tower B, Elephant Tower, 16th Fl., Phaholyothin Road, Chomphon, Chatuchak, Bangkok 10900, Thailand  
 Tel: 66-2-937-4250 Fax: 66-2-937-4254

KOGANEI ASIA PTE. LTD.  
 69 Ubi Road 1, #05-18 Oxley Bizhub, Singapore 408731  
 Tel: 65-6293-4512 Fax: 65-6293-4513