

Electric actuators

Elewave Series

- Electric Hand Flat Type (Standard stroke type/Long stroke type)
- Electric Hand (Standard type/High-speed type)
- Electric Rotary Actuator ● NS Slider

NEW



CC-Link



The CC-Link remote device type has been added to the controller for the electric hand flat type.



Electric hand flat type

The best Low-profile design in the industry!
Lightweight/compact

(*Based on KOGANEI research)



*With the EW2H8

- Contribute to robot downsizing with the low-profile lightweight electric.
- Achieve high-speed robot operation!

Standard stroke type Page ⑩

EW2H8



EW2H18



EW2H28



Long stroke type Page ⑮

EW2HL8



EW2HL18



EW2HL28



<Connector directions>



*One of the above four connector directions can be selected.

	EW2H8	EW2HL8	EW2H18	EW2HL18	EW2H28	EW2HL28
Gripping force (N)	8 to 16		18 to 33		28 to 50	
Open/closed stroke (mm) [in.]	10 [0.394] (5 [0.197] on one side)	32 [1.260] (16 [0.630] on one side)	14 [0.551] (7 [0.276] on one side)	42 [1.654] (21 [0.827] on one side)	18 [0.709] (9 [0.354] on one side)	52 [2.047] (26 [1.024] on one side)
Body mass (kg) [lb]	0.09 [0.198]	0.14 [0.309]	0.16 [0.353]	0.25 [0.551]	0.36 [0.794]	0.48 [1.058]



Unify with auto hand changer and compliance light

Quick start

Quick origin return operation allows swift operation after the controller is powered on or auto hand changer is linked!

*An origin return is recommended after linking with the auto hand changer.

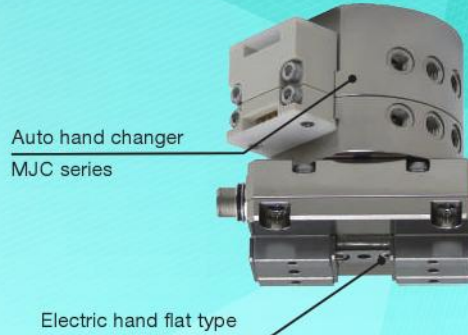
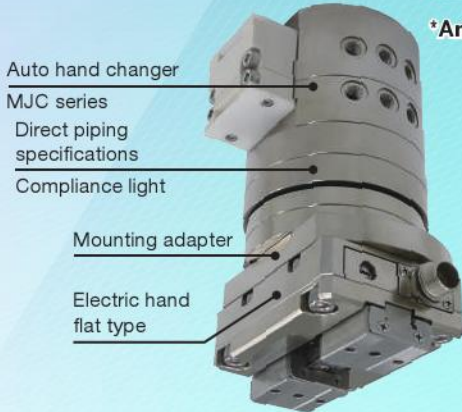

Combinations of through hole (for direct mounting) and tap dimensions enable easy installation!
For information on combining the electric hand flat type with an auto hand changer, see page 69.

Features

Fall prevention function with self-lock mechanism!

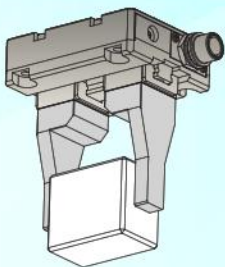

Provides ease of mind in the event of an emergency shutdown or power failure!



*The pushing state is not maintained when the power is OFF.

No worries in case of disconnection!



Immediately solve the problem by replacing the relay cable (robot cable) because the connector is built-in!

Controller

● **Point input type**
 (NPN specifications/PNP specifications)



● **CC-Link Remote I/O type**

CC-Link



For details on the controller, see pages 19 to 22.

NEW

● **CC-Link Remote device type**

CC-Link

Operations previously executed with a teaching box or serial communication can now be controlled with CC-Link only.

- "Literal setting" and "literal operation"
- "Data configuration" for point data and parameter data
- "Data retrieval" for point data and parameter data
- "Data management" for currently occurring alarms and current position, etc.



	CC-Link Remote device type	CC-Link Remote I/O type	Point input type
Each settings	CC-Link or Teaching box or Support software	Teaching box or Support software	Teaching box or Support software
Operation instructions	CC-Link	CC-Link	I/O

Electric actuators

Elewave Series

Based on the concept of a compact and lightweight design at a low-price.

Electric hand

Standard type: EWHA □ A

High-speed type: EWHA □ H Page 31



Compact and lightweight electric hands that support high-speed operation

Standard type



High-speed type



- Soft touch with desired speed control
- Desired stroke setting
- High precision and high rigidity with linear guide
- Mode selection for positioning and gripping force control
- Force control and missed step detection with stepping motor + encoder
- Sense gripping position with communication function
- Size detection enables workpiece selection

Electric rotary actuator

EWHRT

Page 41



Table type rotary actuators (adopting a hollow shaft) with seven torque variations



0.1 N·m [0.9 in·lbf], 0.25 N·m [2.2 in·lbf], 0.5 N·m [4.4 in·lbf], 1.0 N·m [8.9 in·lbf], 2.0 N·m [17.7 in·lbf], 4.0 N·m [35.4 in·lbf], 6.0 N·m [53.1 in·lbf]

Hollow diameter ϕ 6 [0.236] (EWHRT1A, EWHRT3A, EWHRT5A)

ϕ 12 [0.472] (EWHRT10A, EWHRT20A)

ϕ 17 [0.669] (EWHRT40A, EWHRT60A)

- High precision and high resolution positioning (eliminates backlash with unique structure)
- Stepping motor and missed step detection encoder
- Desired swing angle setting (64 points)
- Desired acceleration and deceleration (smooth, shockless operation even at low speed)
- Continuous operation in one direction
- Optional brake (the EWHRT1A has no brake option)

NS slider

EWM5



Page 51

Compact and thin square form actuator to stir creativity



- High-speed type (120 mm/s) [4.724 in/sec] and high thrust type (50 N)
- Short stroke actuator that minimizes dead space in the stroke direction (st 20, 40)
- Long table type suitable for push control selectable
- Multi-point positioning operation available (64 points)
- Desired acceleration and deceleration (smooth, shockless operation even at low speed)
- Soft touch with desired speed control
- High precision and high rigidity with linear guide
- Mode selection for positioning and thrust control
- Force control and missed step detection with stepping motor + encoder
- Sense pushing position with communication function (length measurement function included)
- Size detection enables workpiece selection

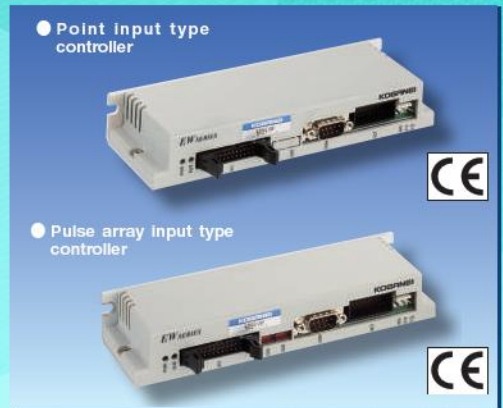

● Point input type controller

● Pulse array input type controller

Support Software

(supports Windows 95, 98, 2000, Me, NT4.0, XP, VISTA, 7, 8, 8.1, and 10*)

*Windows is a registered trademark of Microsoft Corporation.

*The electric hand flat type supports Windows XP (SP3), VISTA, 7, 8, 8.1, and 10

Free-of-charge



- Elewave Series dedicated support software
- Can be downloaded free-of-charge from the KOGANEI website
- Parameters and point data can be edited from the support software
- Movement to a specified point can be performed from the support software

Teaching Box

Page 27, 50



- Settings such as parameters and point data can be configured
- Point movement and teaching movement can be performed
- Simple programming function included



CAUTION Make sure to read the safety precautions on page 8 before use.

Expand the possibilities of manufacturing with user ideas!

Application example

Electric hand flat type unit (1)

Can be directly mounted to an auto hand changer (MJC Series). The low-profile, lightweight design promotes increased takt or more compact sizes for vertical multi-joint robots.

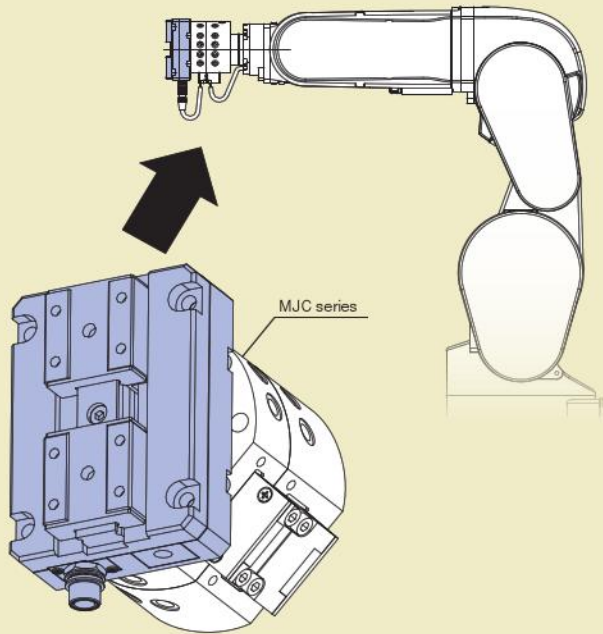

Electric hand flat type unit (2)

Can be mounted to a compliance light (CPL Series) with a dedicated adapter.

Can be directly mounted to the CPL Series or an auto hand changer (MJC Series).

The lightweight design promotes increased takt or more compact sizes for scalar robots.

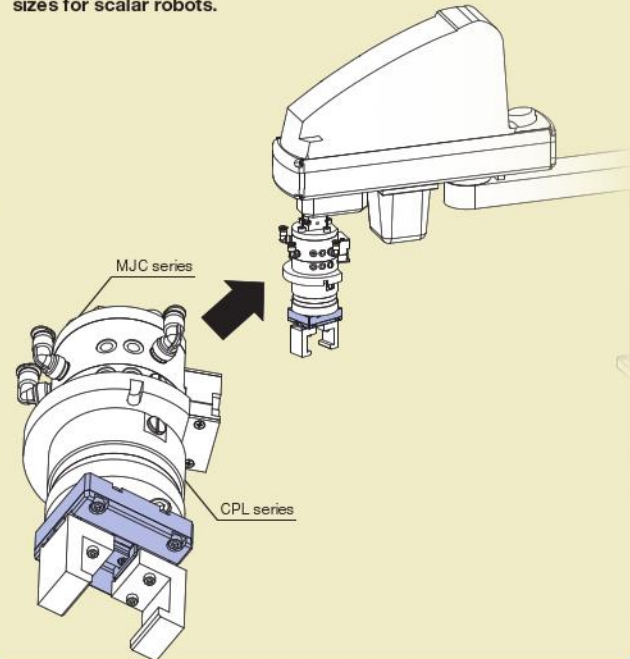

Workpiece Reversal

An electric hand flat type can be used to perform reversal in narrow areas.

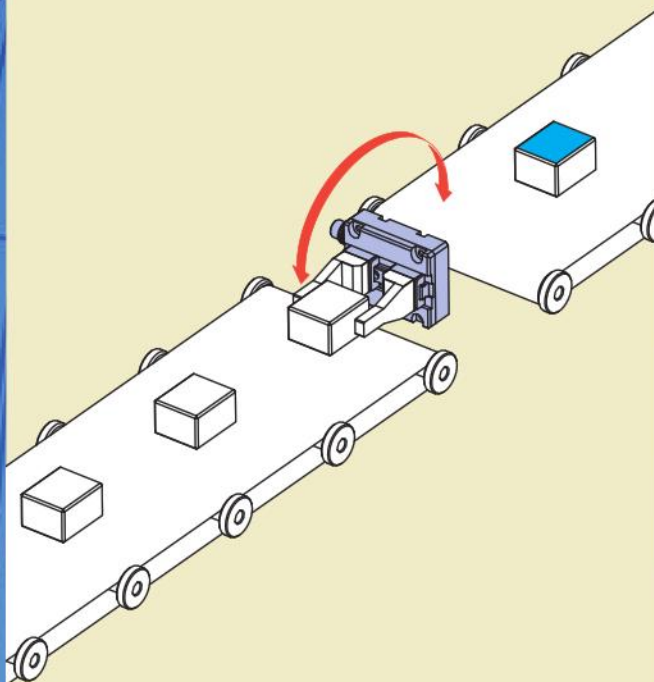

Measurement of Outer Diameter

Example of preventing the inclusion of faulty tube mold items (with a different diameter)

Use the gripping mode and communication function to read external diameter data of the gripped tube to a PC to perform tolerance judgment.

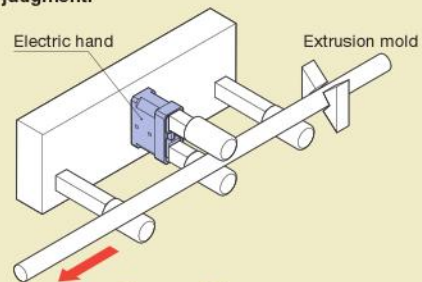

Measurement of Inner Diameter

Example of performing inner diameter judgment on containers and inner diameter judgment after making holes

Attach the jig to the hand tip, and perform tolerance judgment by touching the inner surface of the workpiece with the hand in the gripping mode.

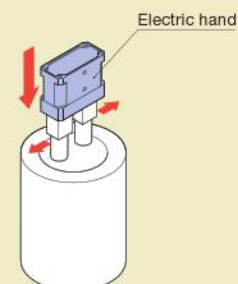

Gripping a Test Tube

Example of gripping delicate workpieces like a test tube

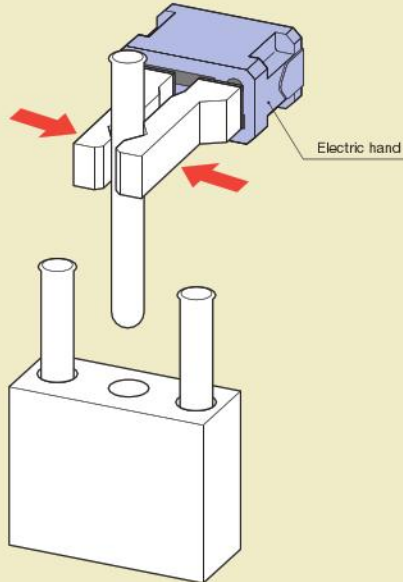

Workpiece Tolerance Determination

Example of preventing the inclusion of workpieces with a different diameter and preventing the leak of faulty items
Grip the workpiece with the gripping mode and perform tolerance judgment.

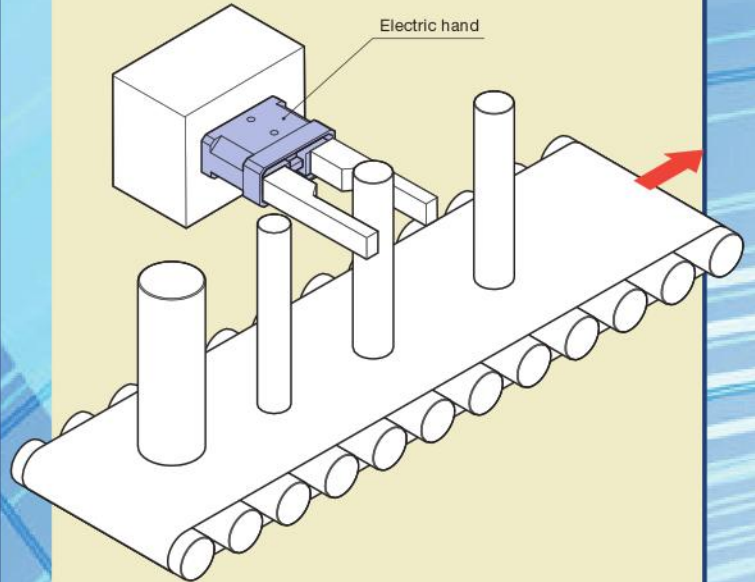

Correction of Parts Position

Example of gripping the workpiece with the positioning mode to perform position control
Perform part positioning correction between pick and place in the IC mounting process. Perform correction in the vertical and horizontal directions simultaneously with two electric hands.

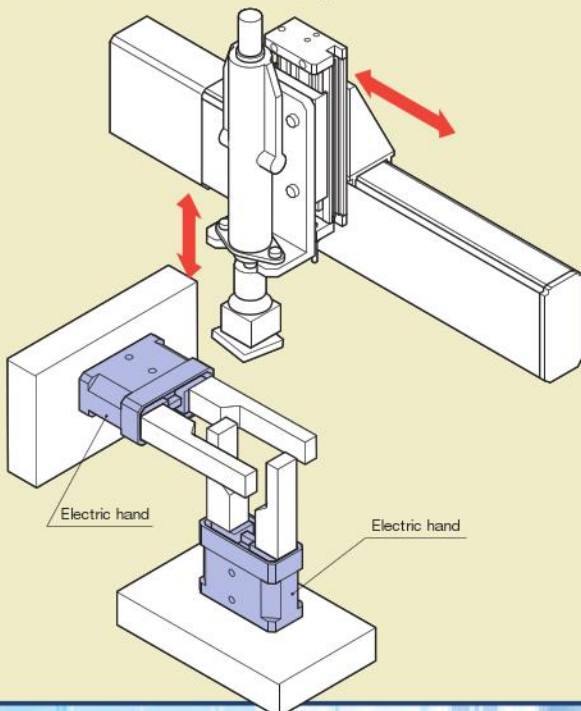

Indexing Table for Automatic Assembly

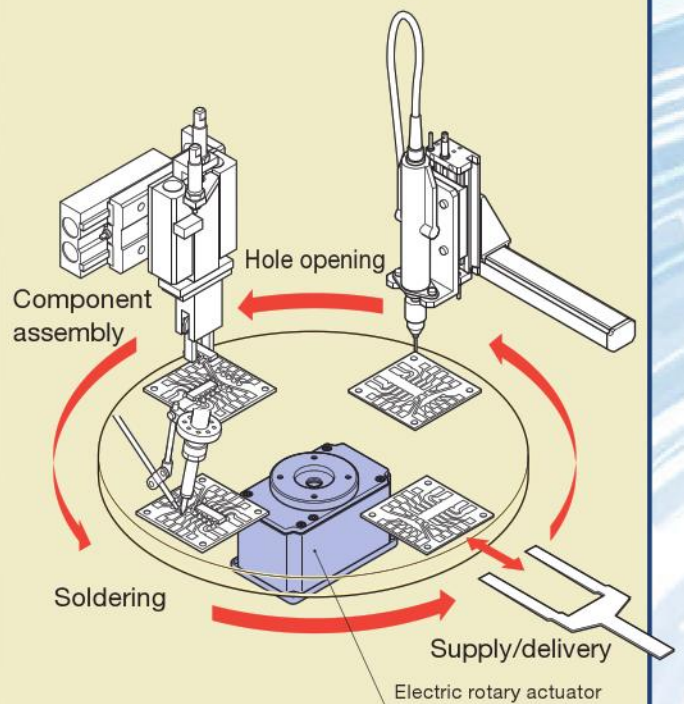

Application example

Swing Loading the Workpiece

Example of tube layout for hollow shaft usage

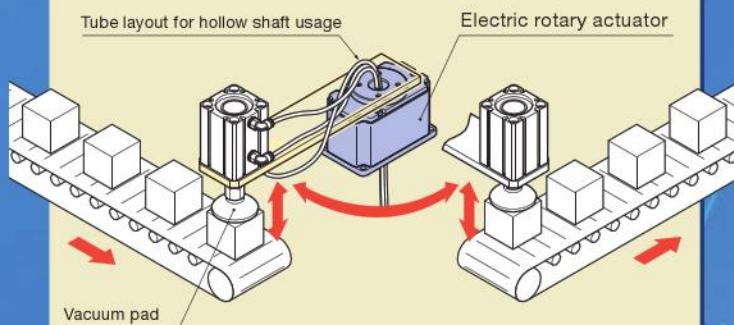

Workpiece Press Fitting

Example of press fitting terminals of compact parts and case caulking, etc.

Perform climb motion with positioning mode and workpiece press fitting with pushing mode. Add judgment function to detect press fitting problems and workpiece chuck errors.

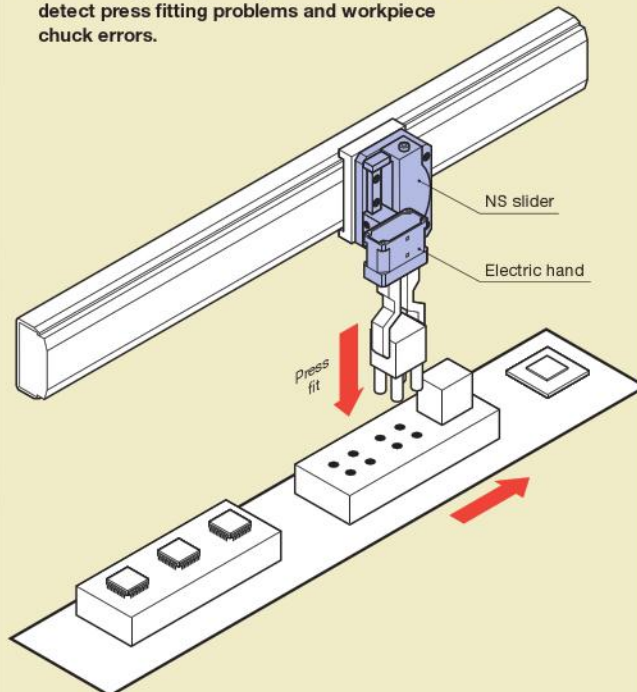

Correction of Parts Position

Example of gripping the workpiece with the positioning mode to perform position control

Perform device positioning correction in the SMT process. Perform correction in the vertical and horizontal directions simultaneously with two NS sliders.

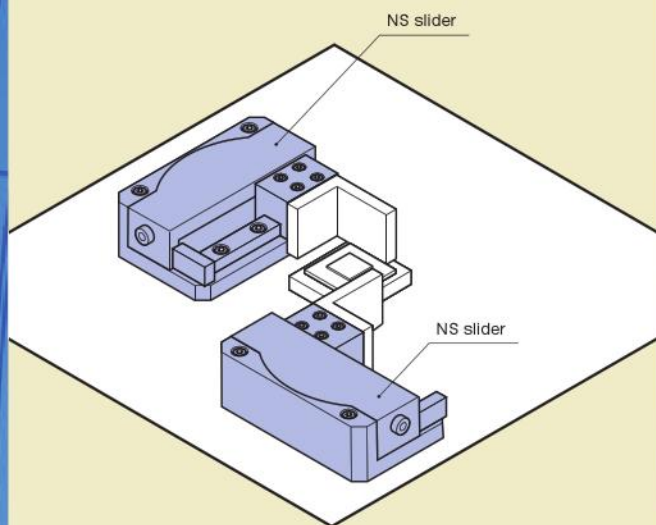

Zone Output (Pulse array input type controller only)



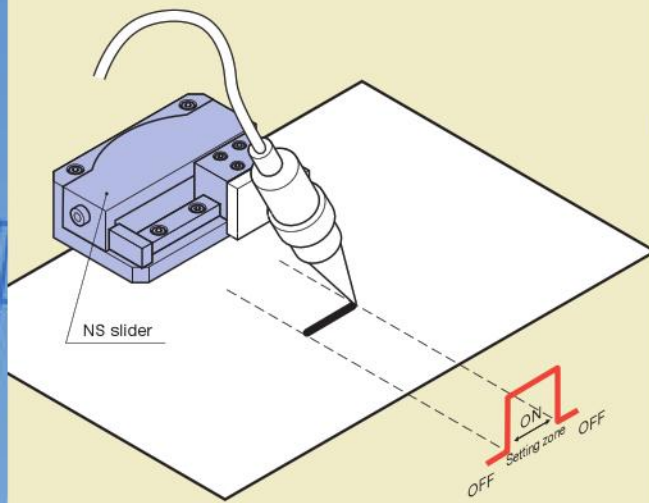

Example of using zone output

Perform dispensing by performing external output at regular intervals via zone output during point movement. This can be used for simple straight line application of solvents and applying a fixed amount of coating, etc.



Before selecting and using the products, please read all the Safety Precautions carefully to ensure proper product use. The Safety Precautions described below are to help you use the product safely and correctly, and to prevent injury or damage to you, other people, and assets. Make sure to also follow the safety regulations in JIS B 8433 (safety requirements for industrial robots).

The directions are ranked according to degree of potential danger or damage: "DANGER", "WARNING", "CAUTION" and "ATTENTION."

 DANGER	Indicates situations that can be clearly predicted as dangerous. Failure to avoid the indicated danger creates the risk of death or serious injury. It could also result in damage or destruction of assets.
 WARNING	Indicates situations that, while not immediately dangerous, could become dangerous. Failure to avoid the indicated danger creates the risk of death or serious injury. It could also result in damage or destruction of assets.
 CAUTION	Indicates situations that, while not immediately dangerous, could become dangerous. Failure to avoid the indicated danger creates the risk of minor or semi-serious injury. It could also result in damage or destruction of assets.
 ATTENTION	While there is little chance of injury, this content refers to points that should be observed for appropriate use of the product.

- **This product was designed and manufactured for use in general industrial machinery.**
- When selecting and handling equipment, the system designer or another person with sufficient knowledge and experience should always read the Safety Precautions, catalog, instruction manual and other documentation before commencing operation. Improper handling is dangerous.
- The customer is responsible for verifying and judging the compatibility of these products with your systems.
- After reading the Instruction Manual, catalog, and other documentation, always store them in a location that allows easy availability for reference to users of this product.
- Whenever transferring or lending the product to another person, always attach the catalog, instruction manual, and other documentation to the product where they are easily visible in order to ensure that the new user can learn how to use the product safely and properly.
- The danger, warning and caution items listed under these Safety Precautions do not cover all possible contingencies. Read the catalog and instruction manual carefully, and always keep safety first.

 **DANGER**

- Do not use the product for the purposes listed below:
 1. Medical equipment related to maintenance or management of human lives or bodies.
 2. Mechanisms, machines, or equipment designed for the purpose of moving or transporting people.
 3. Critical safety components in machines or equipment. This product has not been planned or designed for purposes that require high levels of safety. Using the product in any of the ways described above creates the risk of loss of human life.
- Do not use in locations with or near dangerous substances such as flammable or ignitable substances. The product could ignite or burst into flames.
- While the product is in operation or in the state where it can be operated, avoid entering the operation range of the machine. In addition, do not make any adjustments to the interior or to the attached mechanisms while in operation. The actuator can move suddenly, possibly resulting in injury.
- Persons who use a pacemaker, etc., should keep a distance of at least 1 meter [3.28 ft.] away from the product. There is a possibility that the pacemaker will malfunction due to the magnetism of the strong magnet built into the product.
- When attaching the product, always firmly support and secure them (including workpieces) in place. Dropping or falling of the product or abnormal operation could result in injury.
- Never attempt to modify the product. It could result in abnormal operation leading to injury, electrocution, or fire, etc.
- Never attempt inappropriate disassembly or assembly of the product's basic construction, or of its performance or functions. This could result in injury, electrocution, fire, etc.
- Do not splash water on the product. Splashing it with water, washing it, or using it underwater could result in abnormal operation of the product, leading to injury, electrocution, fire, etc.

 **WARNING**

- Do not use an actuator as a device for absorbing the shocks and vibrations of machines or equipment. Doing so could possibly result in injury or damage to the machines or equipment.
- Do not use the product in excess of its specification range. Doing so creates the risk of product breakdown, loss of function, or damage. It could also drastically reduce operating life.

- Design safety circuits or equipment to ensure that damage to the product or injury does not occur if the device stops in the event of a system error such as an emergency stop or power failure.
- When using the product in the following locations, make sure to implement adequate shielding measures. Failure to do so may lead to a malfunction, which can cause damage to the product or injury.
 1. Locations where large currents and strong magnetic fields are emitted
 2. Locations where noise is emitted due to electrostatic, etc.
 3. Locations that may be exposed to radiation
- Make sure to implement type D grounding (grounding resistance 100 Ω or less). There is a possibility of electrocution and malfunction due to electric leakage.
- Before installing the product to equipment, etc., confirm that the installation, wiring, and operating commands are appropriate. Using the product without checking could possibly result in injury caused by contact with moving parts or damage to the machines or equipment.
- Before supplying electricity to the device and before starting operation, always conduct a safety check of the area of machine operation. Unintentional supply of electricity could possibly result in electrocution, or in injury caused by contact with moving parts.
- Do not touch the terminal and the miscellaneous switches, etc., while the device is powered on. There is a possibility of electrocution and abnormal operation.
- Do not damage the cords such as the cables. Damaging, forcibly bending, pulling, winding, or placing heavy objects on, or pinching cords could result in fire or electrocution due to electric leakage or conduction failure, or cause abnormal operation, etc.
- If abnormal noise is emitted or vibrations become abnormally high, immediately stop operation. Continuing to use the product could result in damage or break it, resulting in abnormal operation, or runaway, etc.
- Do not throw the product into fire. The product could explode and/or release toxic gases.
- Do not sit on the product, place your foot on it, or place other objects on it. Doing so could result in a fall, injury due to the product falling down or falling over, damage to the product, or malfunction or runaway, etc. due to damage.
- When conducting any kind of operation for the product, such as maintenance, inspection, repair, or connection/disconnection or replacement of piping, always turn off the electricity supply completely.
- Use the product within the recommended load and speed.

 **CAUTION**

- Do not use the product in locations that are subject to direct sunlight (ultraviolet rays); locations with high humidity, dust, salt, or iron powder, or atmospheres including organic solvents, phosphate ester type hydraulic oil, sulfur dioxide, chlorine gas, acids, etc. It could lead to early shutdown of some functions, a sudden degradation of performance, and a reduced operating life.
- Do not use the product in atmospheres including corrosive gas, combustible gas, or flammable liquid, etc. It could lead to degraded strength due to rusting or cause the motor to ignite or explode.
- Make sure to use the specified controller for the product. Using another controller may cause product failure or runaway, etc.
- Install the main unit and controller in a location with low levels of dust. Installing them in a location with high levels of dust may cause malfunction.
- Do not install the product in a location subject to strong vibrations (4.9 m/s^2 [0.500 G] or higher). Strong vibrations may cause malfunction.
- When mounting the product, leave room for adequate working space around it. Failure to do so will make it more difficult to conduct routine maintenance, which could eventually lead to system shutdown or damage to the product.
- Do not bring magnetic media, within 1 meter [3.28 ft.] of the product. There is the possibility that the data on the magnetic media will be destroyed due to the magnetism of the magnet.
- Sitting on the product, placing your foot on it, or placing other objects on it may damage, dent, or deform the moving parts. It could damage or break it, resulting in operation shutdown or reduced performance.
- When performing installation or adjustment work, indicate that work is being performed to ensure that the power is not unintentionally turned ON, etc. It could cause electrocution or injury due to sudden actuator operation.
- Never conduct an insulation resistance test or withstand voltage test on the controller.
- Do not apply excessive force to the base of the main unit cable.
- Do not secure the connector of the main unit cable with bending moment applied.

 **ATTENTION**

- When considering the possibility of using this product in situations or environments not specifically noted in the Catalog or Instruction Manual, or in applications where safety is an important requirement such as in an aircraft facility, combustion equipment, leisure equipment, safety equipment, and other places where human life or assets may be greatly affected, take adequate safety precautions such as the application with enough margins for ratings and performance or failsafe measures. Be sure to consult us with such applications.
- Isolate the operating parts of the machines or equipment, etc. with a protective cover, etc. to ensure that they do not come into contact with the human body.
- Configure the control so that the workpiece does not fall down in the event of a power failure.
Implement fall prevention control for workpieces, etc. in the event of a power failure or emergency stop of the machines or equipment.
- Check the instruction manual for information on product installation and wiring.
- When handling the product, wear protective gloves, protective goggles, safety shoes etc. as required to maintain safety.
- Perform routine maintenance to confirm that the system requirements are met in order to prevent accidents.
- When the product becomes unusable or unnecessary, dispose of it properly as industrial waste.
- For inquiries about the product, contact your nearest KOGANEI sales office or the KOGANEI overseas group. The addresses and telephone numbers are shown on the back cover of this catalog.

 **Others**

- Make sure to follow the items below.
 1. When using this product in systems, always use genuine KOGANEI parts or compatible parts (recommended parts). When conducting maintenance and repairs, always use genuine KOGANEI parts or compatible parts (recommended parts). Always observe the prescribed methods and procedures.
 2. Never attempt inappropriate disassembly or assembly of the product's basic construction, or of its performance or functions.

KOGANEI shall not be held responsible for any problems that occur as a result of these items not being properly observed.

Electric hand

Flat type
Standard stroke



Specifications

Main unit basic specifications

Item	Type	EW2H8	EW2H18	EW2H28	
Motor		Brushless motor			
Maximum speed (one side, when using positioning mode)	mm/s [in./sec]	50 [1.969]			
Maximum speed (one side, when using gripping mode)	mm/s [in./sec]	20 [0.787]	30 [1.181]	20 [0.787]	
Minimum speed (one side)	mm/s [in./sec]	5 [0.197]			
Maximum gripping force ¹	N	8 to 16	18 to 33	28 to 50	
Operating temperature range	°C [°F]	0 to 40 [32 to 104]			
Open/closed stroke	mm [in.]	10 [0.394] [5 mm [0.197 in.] on one side]	14 [0.551] [7 mm [0.276 in.] on one side]	18 [0.709] [9 mm [0.354 in.] on one side]	
Repeated positioning precision	mm [in.]	±0.05 [0.002]			
Dynamic allowable moment ²	Mp	N·m [in.-lbf]	0.05 [0.4]	0.1 [0.9]	0.3 [2.7]
	My	N·m [in.-lbf]	0.03 [0.3]	0.1 [0.9]	0.4 [3.5]
	Mr	N·m [in.-lbf]	0.06 [0.5]	0.2 [1.8]	0.8 [7.1]
Maximum payload ³ (one side)	kg [lb]	0.2 (0.1) [0.441 (0.220)]	0.3 (0.15) [0.661 (0.331)]	0.4 (0.2) [0.882 (0.441)]	
Mass	kg [lb]	0.09 [0.198]	0.16 [0.353]	0.36 [0.794]	
Applicable controllers		EW2C-H-NP, EW2C-H-PN, EW2C-H-CC, EW2C-H-CCD			

¹ The maximum gripping force at gripping level 5. For details on the gripping force and gripping speed, see the graph on page 30.

² The dynamic allowable moment is safety coefficient 10 of the static allowable moment (page 29). However, the value is not guaranteed.

³ Total mass of both side claws mounted to table.

Order Codes

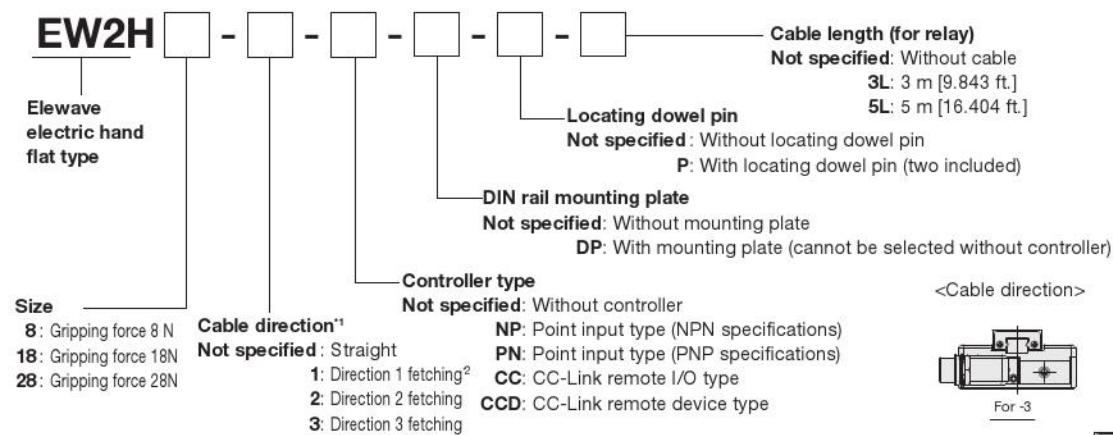

¹ The cable direction cannot be changed after purchase. Select the direction after confirming the state of the settings in advance.

² The EW2H8 and EW2H18 cannot use the straight groove for table operation. The EW2H28 can only use the straight groove when a relay cable is not attached.

Additional Parts

Controller

Point input type

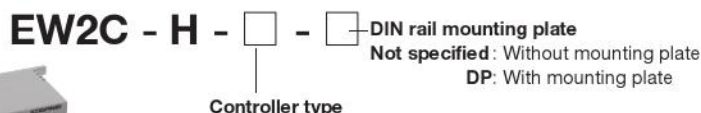

*See pages 19 and 20 for the controller specifications.

CC-Link type



*See pages 20 and 23 for the controller specifications.

Accessories: Power cable, I/O cable



Accessories: Power cable, terminal resistance, connector for CC-Link



Additional parts

● Cable

EW2K -



Length (types P and I cannot be selected)

Not specified: Unspecified

008L: 80 mm [3.150 in.]

015L: 150 mm [5.906 in.]

025L: 250 mm [9.843 in.]

1L: 1 m [3.281 ft.]

3L: 3 m [9.843 ft.]

5L: 5 m [16.404 ft.]

Type

A: For relay

P: For power supply

I: For I/O

D: For daisy chain (for RS485 communication)

N: For communication (for RS485 communication)

BA: Relay cable (loose wire) for main unit*

BB: Relay cable (loose wire) for controller*

*For auto hand changer (MJC) wiring

*The robot cable for relay (A, BA, BB).

Combinations of cable types and lengths

Length Type	008L	015L	025L	1L	3L	5L	Remarks
A	-	-	-	-	○	○	For relay
P	-	-	-	-	-	-	For power supply
I	-	-	-	-	-	-	For I/O
D	○	-	-	○	○	-	For daisy chain (for RS485 communication)
N	-	-	-	○	○	-	For communication (for RS485 communication)
BA	-	○	○	-	-	-	Main unit/loose wire specifications
BB	-	-	-	-	○	○	Controller/loose wire specifications



EW2KA: For relay



EW2KP: For power supply



EW2KI: For I/O



EW2KD: For daisy chain (for RS485 communication)



EW2KBA: Relay cable (loose wire) for main unit



EW2KN: For communication (for RS485 communication)



EW2KBB: Relay cable (loose wire) for controller

● Communication cable (USB-RS485 converter)

IBM2A - H1 -



Not specified: With USB cable

N: Without USB cable

● Terminal resistance

(for RS485 communication) **EW2FR** (for CC-Link) **EW2FC**



● Connector for CC-Link

EW2CC



● Branch connector for CC-Link

EW2CY



● Teaching box

EW2TB

*See page 20 for the specifications.



● DIN rail mounting plate

EW2DP



● Adapter for compliance light (CPLHB) installation

EW2A - H

Size (gripping force)

8 : 8 N (for CPL□34□)

18 : 18 N (for CPL□54□)

28 : 28 N (for CPL□70□)



[Included parts]

Locating dowel pin

Mounting bolt



(g[oz.])

Type	EW2A-H8	EW2A-H18	EW2A-H28
Mass	40 [1.411]	76 [2.681]	116 [4.092]

*With included parts

● Locating dowel pin (x 1)

EW2P -



Size

3: ϕ 3 [0.118] (for EW2□8, EW2□18)

4: ϕ 4 [0.157] (for EW2□28)

EW2H

EW2HL

EWHA □ A

EWHA □ H

EWHT

EW5

Material

EW2H8

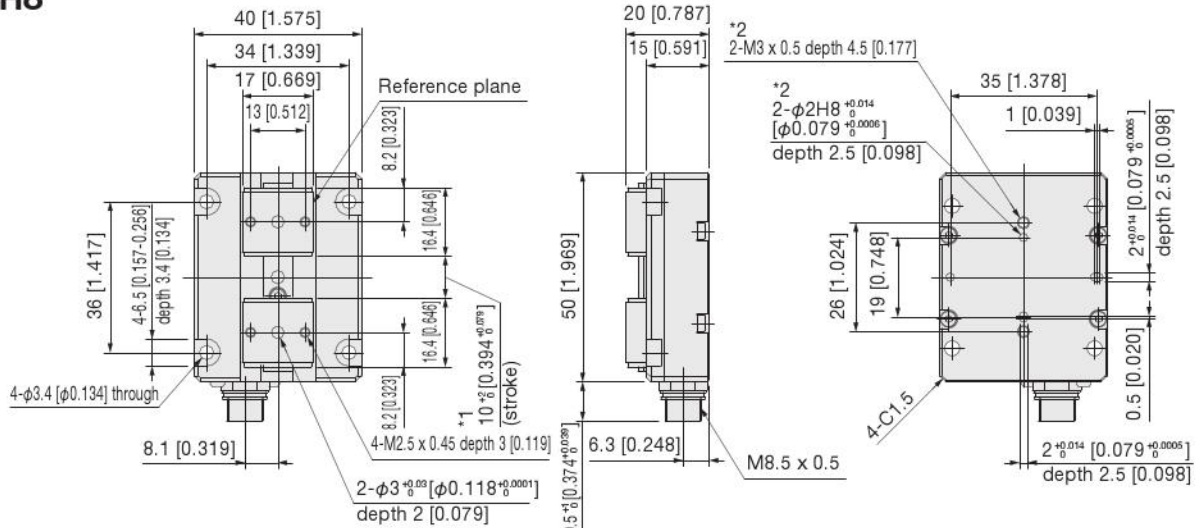

*1 Dimensions of the origin position on the open side. Use the origin shift function when it is necessary to adjust the origin position.
 *2 Can be directly mounted to a KOGANEI auto hand changer (MJC3T).

Cable direction: 1, 2, or 3

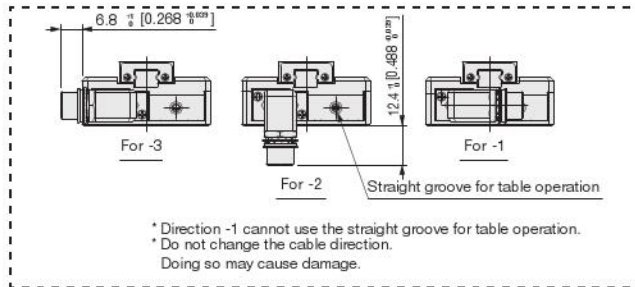
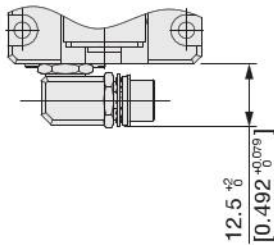

EW2H18

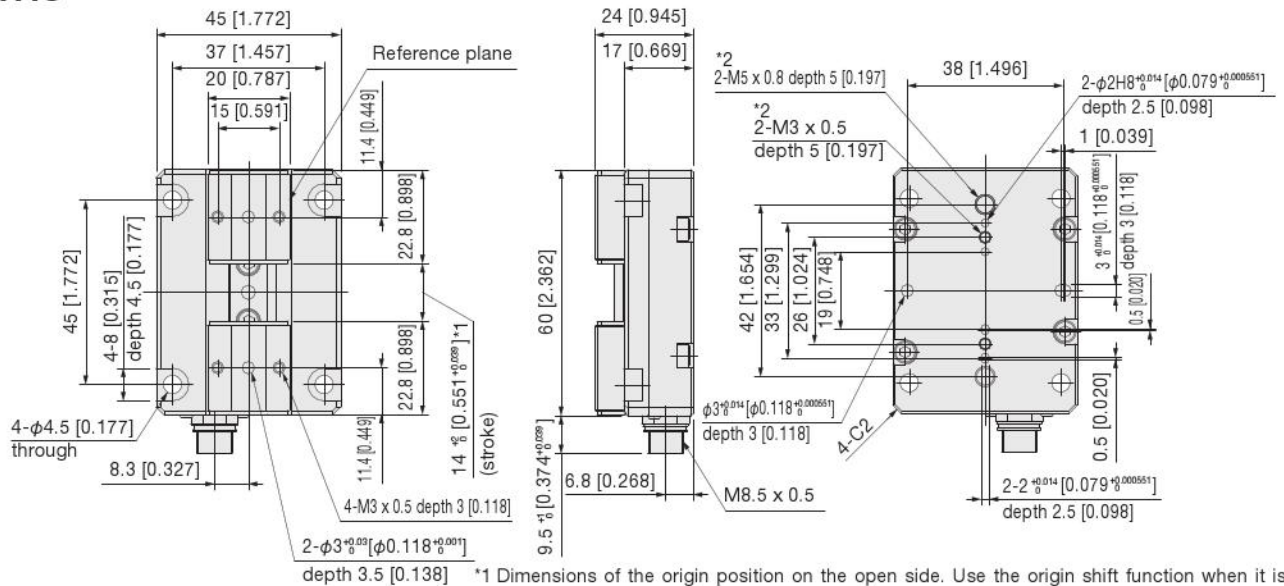

*1 Dimensions of the origin position on the open side. Use the origin shift function when it is necessary to adjust the origin position.
 *2 Can be directly mounted to a KOGANEI auto hand changer (MJC3T or MJC10T).

Cable direction: 1, 2, or 3

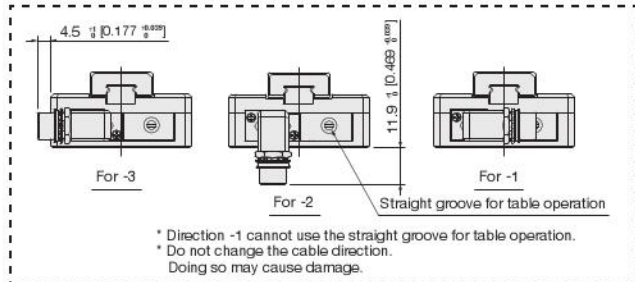
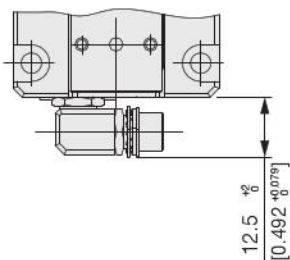

EW2H28

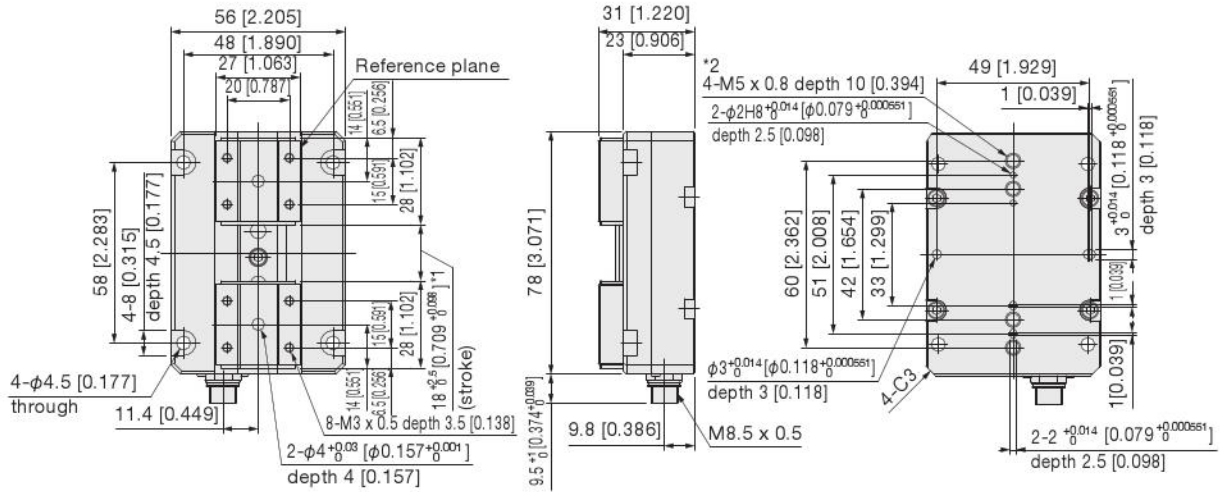

*1 Dimensions of the origin position on the open side. Use the origin shift function when it is necessary to adjust the origin position.

*2 Can be directly mounted to a KOGANEI auto hand changer (MJC10T or MJC20T).

Cable direction: 1, 2, or 3

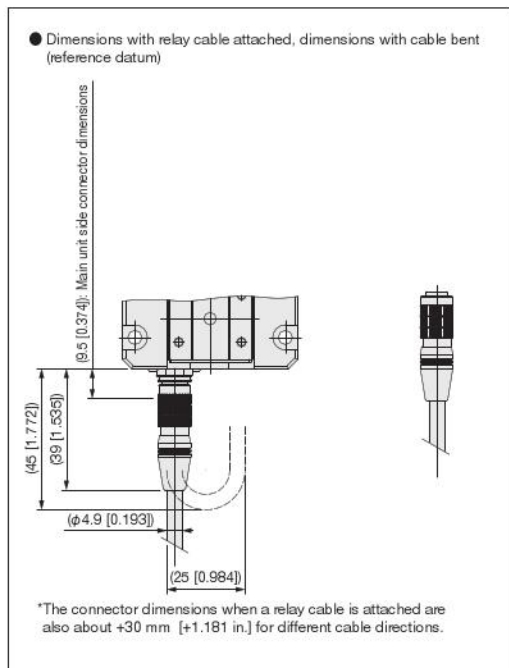
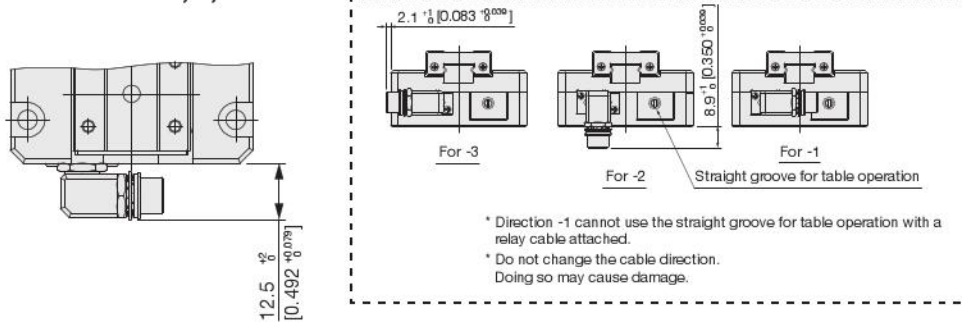

EW2H

EW2HL

EWHA □ A

EWHA □ H

EWHRT

EWM5

Material

Additional parts

● Cable

EW2K

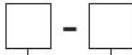

Length (types P and I cannot be selected)

Not specified: Unspecified
008L: 80 mm [3.150 in.]
015L: 150 mm [5.906 in.]
025L: 250 mm [9.843 in.]
1L: 1 m [3.281 ft.]
3L: 3 m [9.843 ft.]
5L: 5 m [16.404 ft.]

Type

A: For relay
P: For power supply
I: For I/O
D: daisy chain (for RS485 communication)
N: For communication (for RS485 communication)
BA: Relay cable (loose wire) for main unit*
BB: Relay cable (loose wire) for controller*

*For auto hand changer (MJC) wiring
 *The robot cable for relay (A, BA, BB).

Combinations of cable types and lengths

Length Type	008L	015L	025L	1L	3L	5L	Remarks
A	-	-	-	-	○	○	For relay
P	-	-	-	-	-	-	For power supply
I	-	-	-	-	-	-	For I/O
D	○	-	-	○	○	-	For daisy chain (for RS485 communication)
N	-	-	-	○	○	-	For communication (for RS485 communication)
BA	-	○	○	-	-	-	Main unit/loose wire specifications
BB	-	-	-	-	○	○	Controller/loose wire specifications



EW2KA: For relay



EW2KP: For power supply



EW2KI: For I/O



EW2KD: For daisy chain (for RS485 communication)



EW2KBA: Relay cable (loose wire) for main unit



EW2KN: For communication (for RS485 communication)



EW2KBB: Relay cable (loose wire) for controller

● Communication cable (USB-RS485 converter)

IBM2A - H1



Not specified: With USB cable
N: Without USB cable

● Terminal resistance (for RS485 communication)

EW2FR



(for CC-Link)

EW2FC



● Connector for CC-Link

EW2CC



● Branch connector for CC-Link

EW2CY



● Teaching box

EW2TB



*See page 27 for the specifications.

● DIN rail mounting plate

EW2DP



● Adapter for compliance light (CPLHB) installation

EW2A - H



Size (gripping force)
8: 8 N (for CPL□34□)
18: 18 N (for CPL□54□)
28: 28 N (for CPL□70□)



[Included parts]
 Locating dowel pin
 Mounting bolt



(g [oz.])

Type	EW2A-H8	EW2A-H18	EW2A-H28
Mass	40 [1.411]	76 [2.681]	116 [4.092]

*With included parts

● Locating dowel pin (x 1)

EW2P



Size

3: φ3 [0.118] (for EW2□8, EW2□18)
4: φ4 [0.157] (for EW2□28)

EW2H

EW2HL

EWHA □ A

EWHA □ H

EWHR

EW5M

Material

EW2HL8

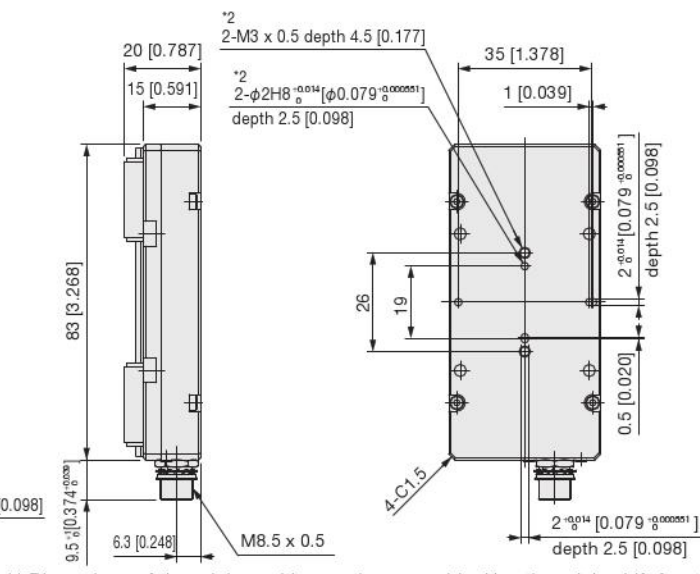
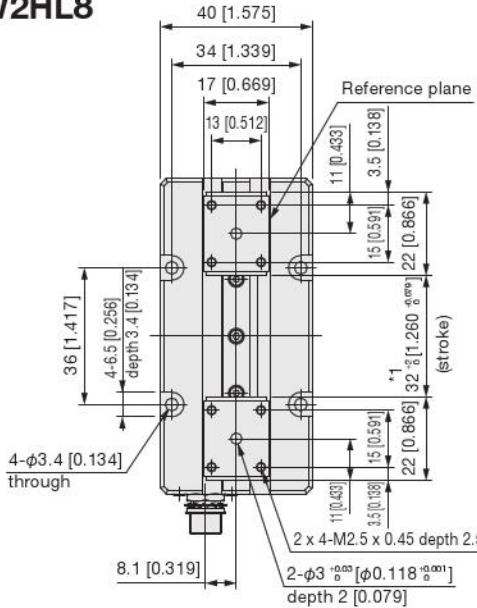

Cable direction: 1, 2, or 3

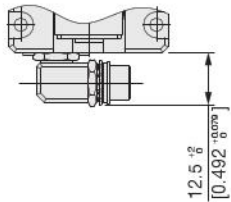

*1 Dimensions of the origin position on the open side. Use the origin shift function when it is necessary to adjust the origin position.

*2 Can be directly mounted to a KOGANEI auto hand changer (MJC3T).

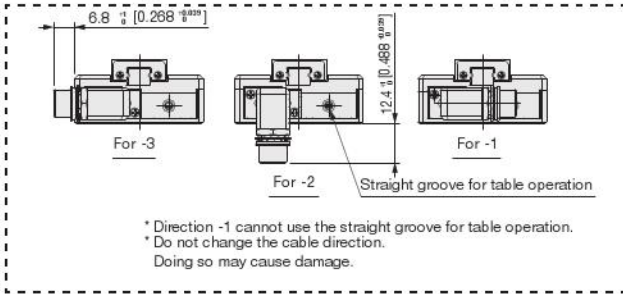

* Direction -1 cannot use the straight groove for table operation.
* Do not change the cable direction.
Doing so may cause damage.

EW2HL18

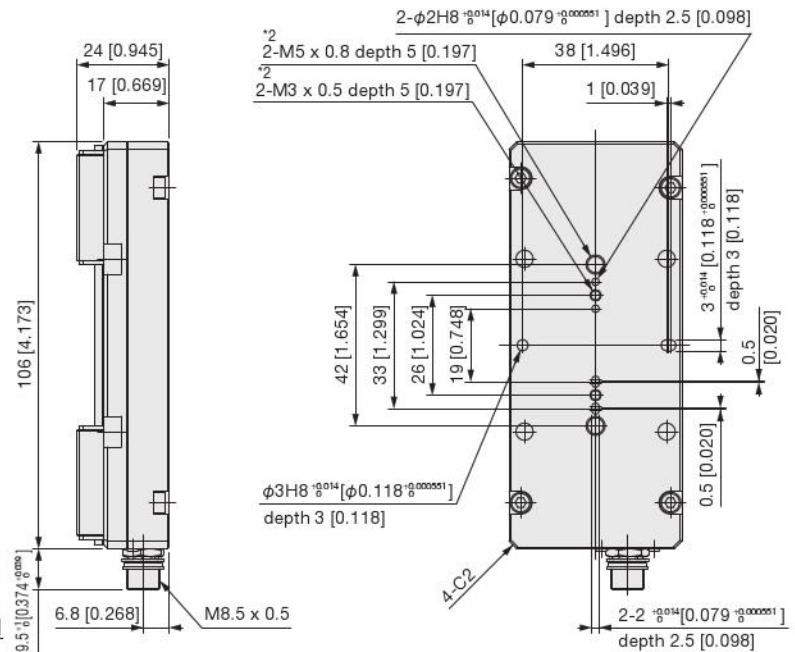
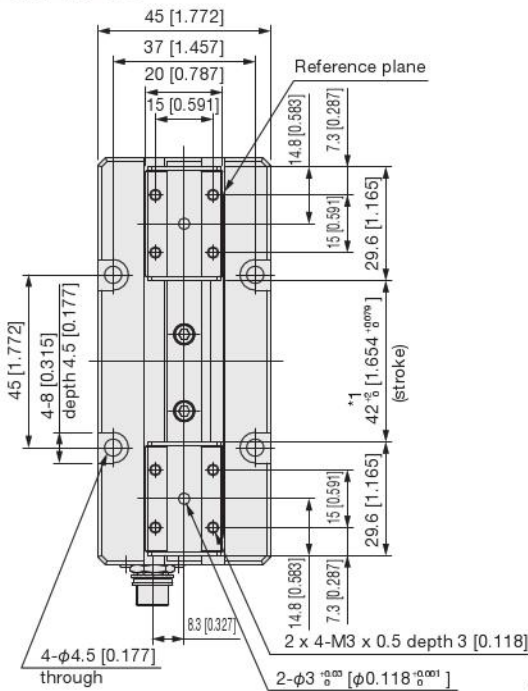

Cable direction: 1, 2, or 3

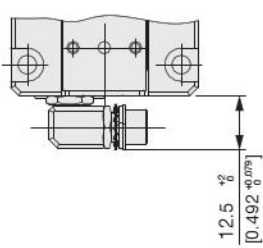

*1 Dimensions of the origin position on the open side. Use the origin shift function when it is necessary to adjust the origin position.

*2 Can be directly mounted to a KOGANEI auto hand changer (MJC3T or MJC10T).

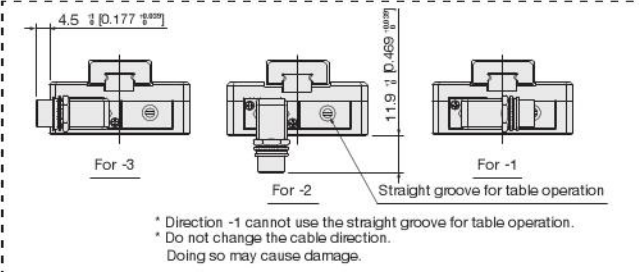

* Direction -1 cannot use the straight groove for table operation.
* Do not change the cable direction.
Doing so may cause damage.

EW2HL28

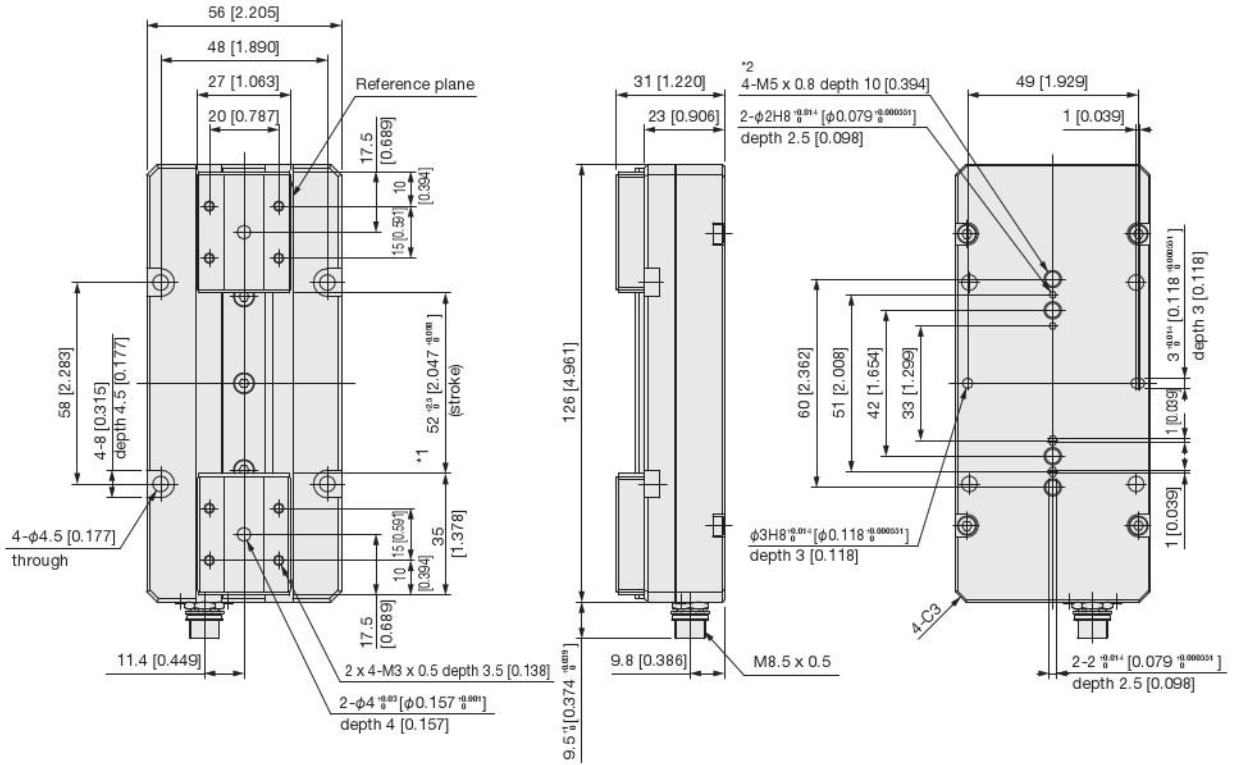

*1 Dimensions of the origin position on the open side. Use the origin shift function when it is necessary to adjust the origin position.
 *2 Can be directly mounted to a KOGANEI auto hand changer (MJC10T or MJC20T).

Cable direction: 1, 2, or 3

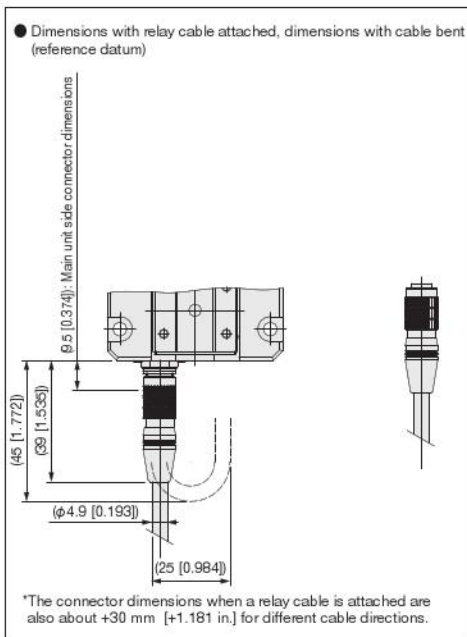
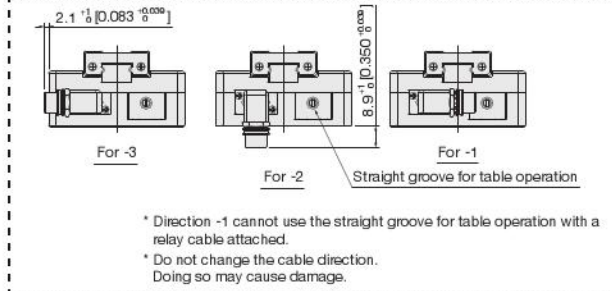
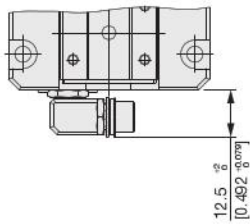

EW2H

EW2HL

EWHA □ A

EWHA □ H

EWHRT

EWMS

Material

Controller

Point input type NPN Specifications



Specifications

Item	Type	EW2C-H-NP
Control specifications	Motor drive system	Square wave drive
	Control method	Closed loop control ^{*1}
	Operating method	PTP, force control
	Origin detection method	Stroke end detection
	Position detection method	Hall IC output
	Minimum setting distance	0.05 mm [0.002 in.]
	Point setting	32 points
	Point input method	Numeric input, teaching input, direct teaching
	Point setting input	5 points (POS0~POS4)
	Control input	3 points (ORG, START, STOP)
	Control output	4 points (READY, BUSY, HOLD, INPOS)
	Error detection output	Time over, wiring disconnection, data error, system error
	Motor drive cable	
Hall IC cable		
RS485 Communication method	External communication	RS485 1 ch (computer, TB communication) Daisy chain available (maximum 16 connections)
	Communication method	Half duplex
	Synchronous method	Start-stop synchronization
	Communication speed	115.2 kbps
	Parity bit	Odd
	Communication distance	Total cable length 100 m [328.084 ft.] or less
Communication cable	Dedicated cable (two pair twisted shielded cable)	
General specifications	Mass	0.2 kg [0.441 lb]
	Power supply	DC 24 V±10 % 1.6 A Max (common power supply with RS485 communication)
	Power supply indication	PWR
	Operating temperature range	0 to 40 °C [32 to 104°F]
	Operating humidity range	35 to 85 % RH (without condensation)
	Storage temperature range	-10 to 65 °C [14 to 149°F]
	Backup	Setting conditions retained in EEPROM
	Noise resistance	IEC61000-4-4 level 3
Accessories	I/O cable, power cable	

*1 Missed step detection is performed with a Hall IC.

Controller Wiring Method

1. When using the internal power supply of the controller

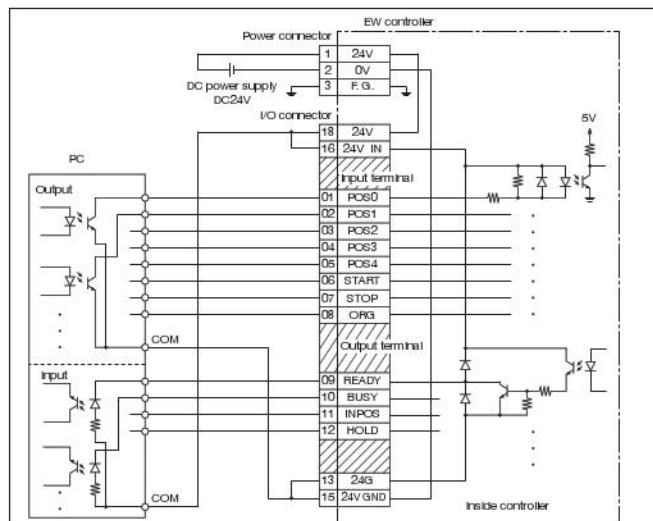

2. When not using the internal power supply of the controller

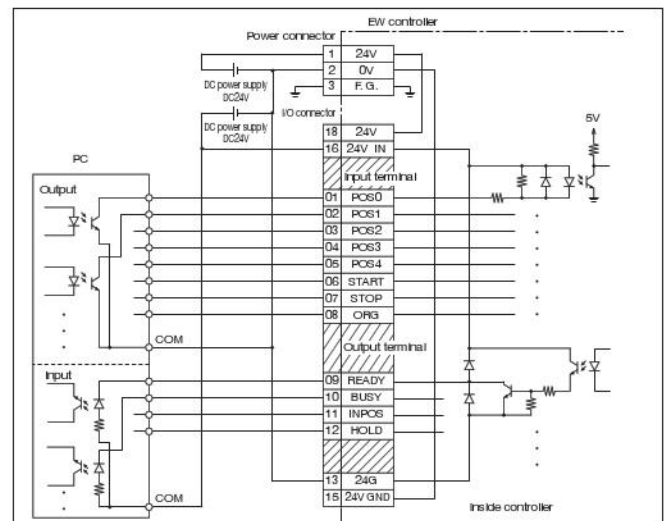

Controller

Point input type PNP Specifications



Specifications

Item	Type	EW2C-H-PN
Control specifications	Motor drive system	Square wave drive
	Control method	Closed loop control*
	Operating method	PTP, force control
	Origin detection method	Stroke end detection
	Position detection method	Hall IC output
	Minimum setting distance	0.05 mm [0.002 in.]
	Point setting	32 points
	Point input method	Numeric input, teaching input, direct teaching
	Point setting input	5 points (POS0~POS4)
	Control input	3 points (ORG, START, STOP)
	Control output	4 points (READY, BUSY, HOLD, INPOS)
	Error detection output	Time over, wiring disconnection, data error, system error
	Motor drive cable	Motor drive output, Hall IC input dedicated cable (F.G, shielded)
	Hall IC cable	
RS485 Communication method	External communication	RS485 1 ch (computer, TB communication) Daisy chain available (maximum 16 connections)
	Communication method	Half duplex
	Synchronous method	Start-stop synchronization
	Communication speed	115.2 kbps
	Parity bit	Odd
	Communication distance	Total cable length 100 m [328.084 ft.] or less
Communication cable	Dedicated cable (two pair twisted shielded cable)	
General specifications	Mass	0.2 kg [0.441 lb]
	Power supply	DC 24 V±10 % 1.6 A Max (common power supply with RS485 communication)
	Power supply indication	PWR
	Operating temperature range	0 to 40 °C [32 to 104°F]
	Operating humidity range	35 to 85 % RH (without condensation)
	Storage temperature range	-10 to 65 °C [14 to 149°F]
	Backup	Setting conditions retained in EEPROM
	Noise resistance	IEC61000-4-4 level 3
Accessories	I/O cable, power cable	

*1 Missed step detection is performed with a Hall IC.

Controller Wiring Method

1. When using the internal power supply of the controller

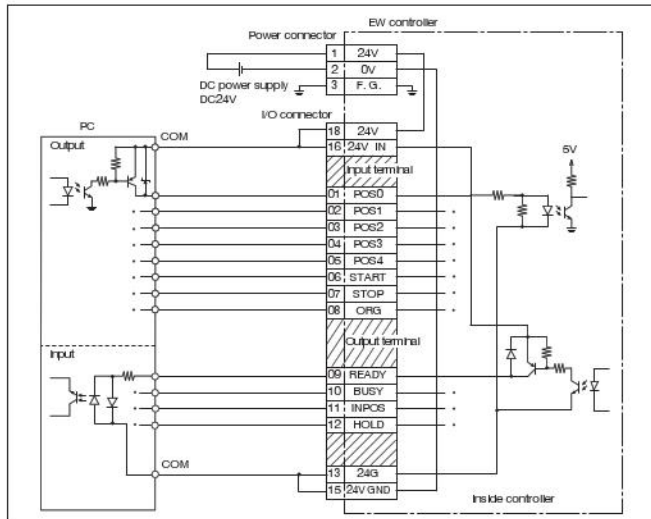

2. When not using the internal power supply of the controller

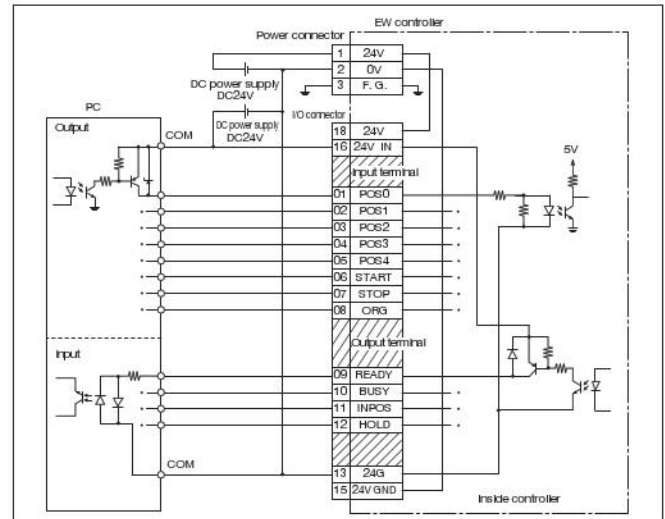

Controller

CC-Link Remote I/O Type



Specifications

Item	Type	EW2C-H-CC					
Control specifications	Motor drive system	Square wave drive					
	Control method	Closed loop control ^{*1}					
	Operating method	PTP, force control					
	Origin detection method	Stroke end detection					
	Position detection method	Hall IC output					
	Minimum setting distance	0.05 mm [0.002 in.]					
	Point setting	32 points					
	Point input method	Numeric input, teaching input, direct teaching					
	Point setting input	5 points (POS0~POS4)					
	Control input	3 points (ORG, START, STOP)					
	Control output	4 points (READY, BUSY, HOLD, INPOS)					
	Error detection output	Time over, wiring disconnection, data error, system error					
	Motor drive cable	Motor drive output, Hall IC input dedicated cable (F.G, shielded)					
Hall IC cable							
RS485 Communication method	External communication	RS485 1 ch (computer, TB communication) Daisy chain available (maximum 16 connections)					
	Communication method	Half duplex					
	Synchronous method	Start-stop synchronization					
	Communication speed	115.2 kbps					
	Parity bit	Odd					
	Communication distance	Total cable length 100 m [328.084 ft.] or less					
	Communication cable	Dedicated cable (two pair twisted shielded cable)					
General specifications	Mass	0.2 kg [0.441 lb]					
	Power supply	DC 24 V±10 % 1.6 A Max (common power supply with RS485 communication and CC-Link communication)					
	Power supply indication	PWR					
	Operating temperature range	0 to 40 °C [32 to 104°F]					
	Operating humidity range	35 to 85 % RH (without condensation)					
	Storage temperature range	-10 to 65 °C [14 to 149°F]					
	Backup	Setting conditions retained in EEPROM					
	Noise resistance	IEC61000-4-4 level 3					
	Accessories	CC-Link connector, power cable, CC-Link terminal resistance					
CC-Link Communication specifications	Version	Ver.1.10					
	Communication method	Broadcast polling method					
	Synchronous method	Frame synchronization method					
	Transmission line method	Bus format (EIA RS485 compliant)					
	Communication speed	Switch between 156 k/625 k/2.5 M/5 M/10 Mbps (rotary switch)					
	Occupied station count	One remote I/O station					
	Maximum connected device count	64 devices					
	Station number setting	Switch from 1 to 64 (rotary switch)					
	CLEAR/HOLD	Switch (DIP switch) CLEAR: When a CC-Link communication error occurs, data other than the controller connection are cleared HOLD: When a CC-Link communication error occurs, the state before the error occurred is retained					
	Indication	PW, L RUN, SD, RD, L ERR (red LED)					
	Transmission distance	Communication speed (bps)	156 k	625 k	2.5 M	5 M	10 M
		Total cable length (m [ft.])	1200 [3,937.008]	900 [2,952.756]	400 [1,312.336]	160 [524.934]	100 [328.084]
	Communication cable	Dedicated CC-Link cable supporting Ver.1.10					
Terminal resistance	110 Ω (when using dedicated CC-Link cable supporting Ver.1.10)						

^{*1} Missed step detection is performed with a Hall IC.

Controller

CC-Link remote device type



EW2H

EW2HL

EWHA A

EWHA H

EWHRT

EWMS

Material

Specifications

Item	Type	EW2C-H-CCD					
Control specifications	Motor drive system	Square wave drive					
	Control method	Closed loop control ^{*1}					
	Operating method	PTP, force control					
	Origin detection method	Stroke end detection					
	Position detection method	Hall IC output					
	Minimum setting distance	0.05 mm [0.002 in.]					
	Point setting	32 points					
	Point input method	Numeric input, teaching input, direct teaching					
	Point setting input	5 points (POS0~POS4)					
	Error detection output	Time over, wiring disconnection, data error, system error					
	Motor drive cable	Motor drive output, Hall IC input dedicated cable (F.G, shielded)					
	Hall IC cable						
RS485 Communication method	External communication	RS485 1 ch (computer, TB communication) Daisy chain available (maximum 16 connections)					
	Communication method	Half duplex					
	Synchronous method	Start-stop synchronization					
	Communication speed	115.2 kbps					
	Parity bit	Odd					
	Communication distance	Total cable length 100 m [328.084 ft.] or less					
	Communication cable	Dedicated cable (two pair twisted shielded cable)					
General specifications	Mass	0.2 kg [0.441 lb]					
	Power supply	DC 24 V±10 % 1.6 A Max (common power supply with RS485 communication and CC-Link communication)					
	Power supply indication	PWR					
	Operating temperature range	0 to 40 °C [32 to 104°F]					
	Operating humidity range	35 to 85 % RH (without condensation)					
	Storage temperature range	-10 to 65 °C [14 to 149°F]					
	Backup	Setting conditions retained in FRAM					
	Noise resistance	IEC61000-4-4 level 3					
	Accessories	CC-Link connector, power cable, CC-Link terminal resistance					
CC-Link Communication specifications	Version	Ver.1.10					
	Communication method	Broadcast polling method					
	Synchronous method	Frame synchronization method					
	Transmission line method	Bus format (EIA RS485 compliant)					
	Communication speed	Switch between 156 k/625 k/2.5 M/5 M/10 Mbps (rotary switch)					
	Occupied station count	1/2/4 remote device stations (parameter switch)					
	Maximum connected device count	1 station occupied: 42 devices; 2 stations occupied: 32 devices; 4 stations occupied: 16 devices					
	Station number setting	Switch (rotary switch) 1 station occupied: 1 to 64; 2 stations occupied: 1 to 63; 4 stations occupied: 1 to 61					
	CLEAR/HOLD	Switch (DIP switch) CLEAR: When a CC-Link communication error occurs, data other than the controller connection are cleared HOLD: When a CC-Link communication error occurs, the state before the error occurred is retained					
	Indication	PW, L RUN, SD, RD, L ERR (blue LED)					
	Transmission distance	Communication speed (bps)	156 k	625 k	2.5 M	5 M	10 M
		Total cable length (m [ft.])	1200 [3,937.008]	900 [2,952.756]	400 [1,312.336]	160 [524.934]	100 [328.084]
	Communication cable	Dedicated CC-Link cable supporting Ver.1.10					
Terminal resistance	110 Ω (when using dedicated CC-Link cable supporting Ver.1.10)						

*1 Missed step detection is performed with a Hall IC.

Dimensions mm [in.]

● Controller

Point input type

EW2C-H-

DIN rail mounting plate
 Not specified: Without mounting plate
 DP: With mounting plate

Controller type

NP: Point input type (NPN specifications)
 PN: Point input type (PNP specifications)

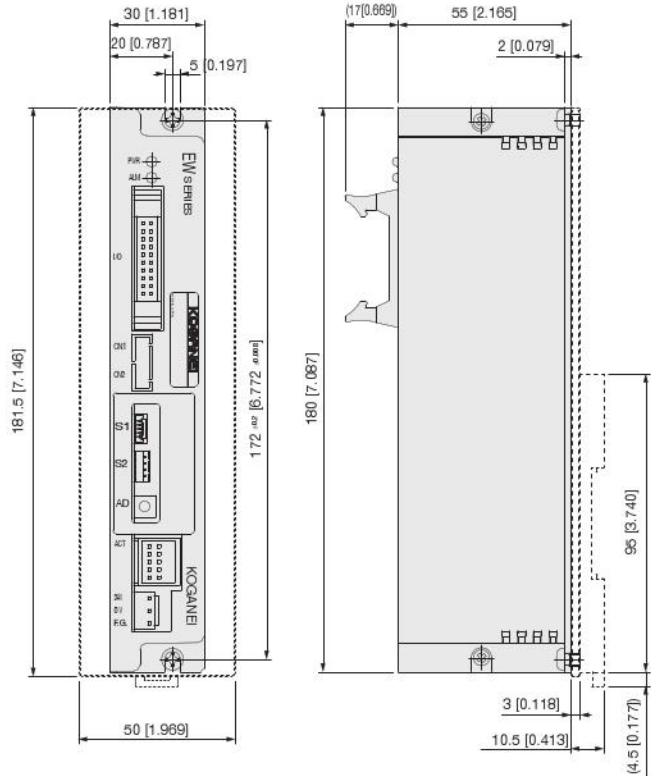

*The dotted line indicates the DIN rail mounting plate dimensions

CC-Link type

EW2C-H-

DIN rail mounting plate
 Not specified: Without mounting plate
 DP: With mounting plate

Controller type

CC: CC-Link remote I/O type
 CCD: CC-Link remote device type

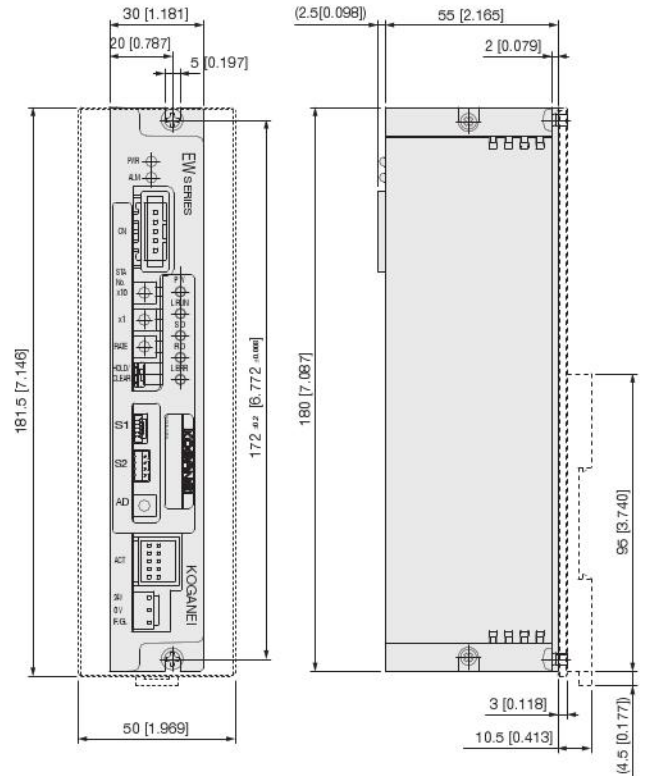

*The dotted line indicates the DIN rail mounting plate dimensions

● DIN rail mounting plate

EW2DP

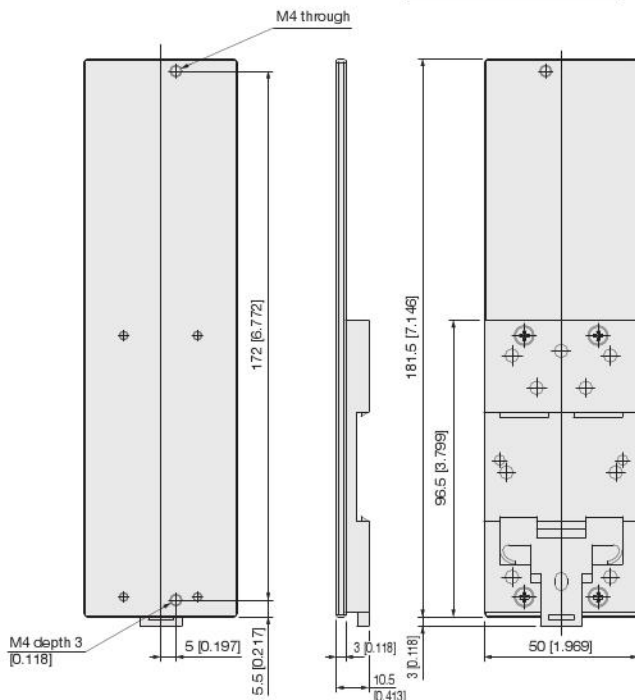
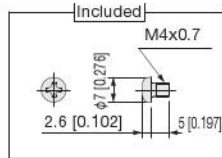

● Connector for CC-Link

EW2CC

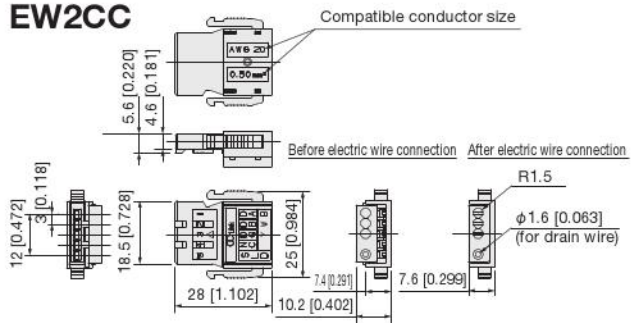

*This connector is compatible with the cable for CC-Link communication.

● Branch connector for CC-Link

EW2CY

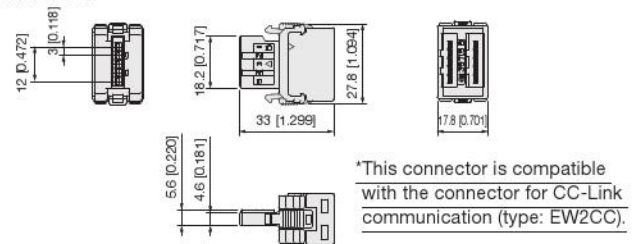

● Terminal resistance (for CC-Link)

EW2FC

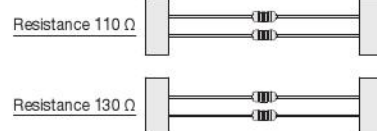

Dimensions mm [in.]

● Cable (robot cable)

• For relay

EW2KA- □
 3L: 3 m [9.843 ft.]
 5L: 5 m [16.404 ft.]

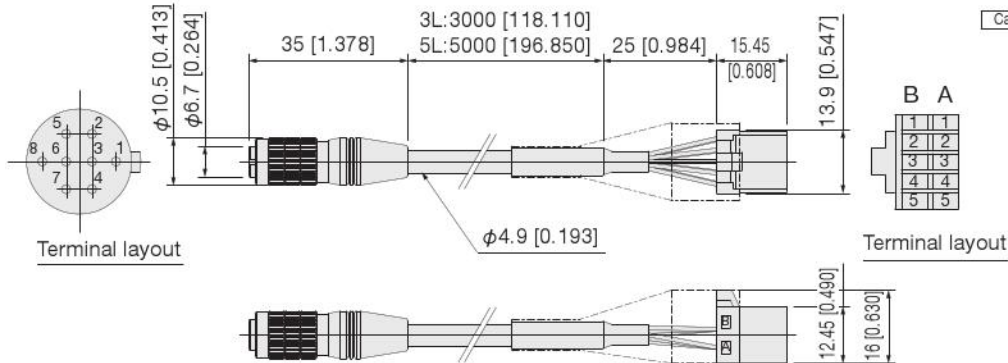

• For power supply

EW2KP

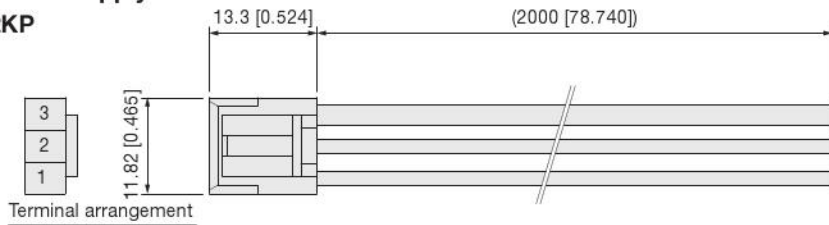

• For I/O

EW2KI

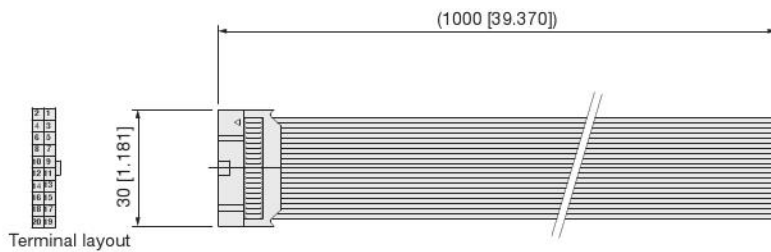

• For daisy chain (for RS485 communication)

EW2KD - □
 008L: 80 mm [3.150 in.]
 1L: 1 m [3.281 ft.]
 3L: 3 m [9.843 ft.]

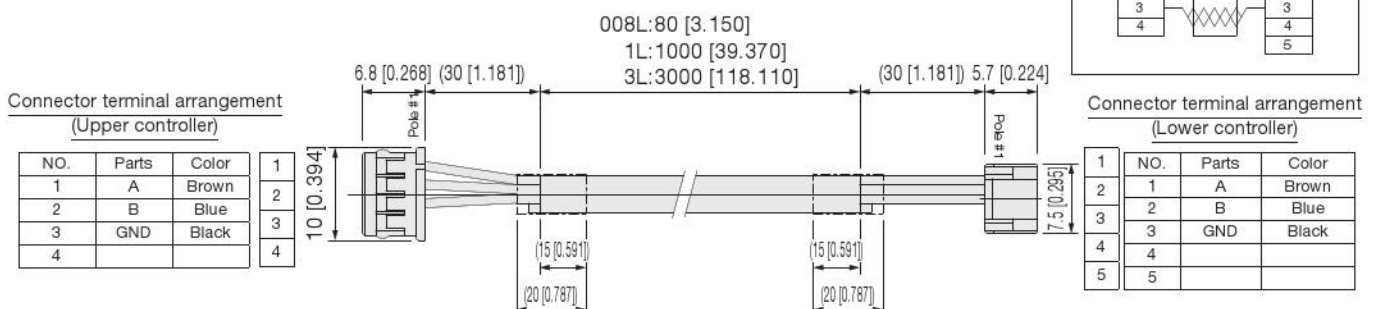

Dimensions mm [in.]

• For communication (for RS485 communication)

EW2KN - □

1L: 1 m [3.281 ft.]
3L: 3 m [9.843 ft.]

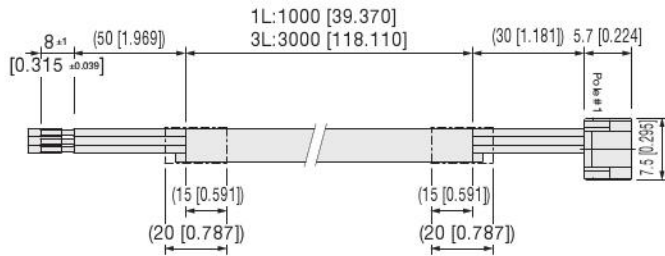

Cable wire chart

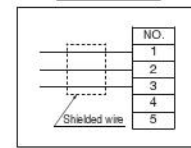

Connector terminal arrangement (Lower controller)

NO.	Parts	Color
1	A	White
2	B	Pink
3	GND	Yellow
4		
5		

• USB-RS485 converter for communication

IBM2A - H1 - □

Not specified: With USB cable
N: Without USB cable

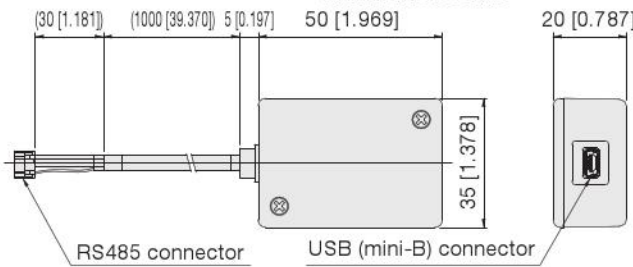

● Terminal resistance (for RS485 communication)

EW2FR

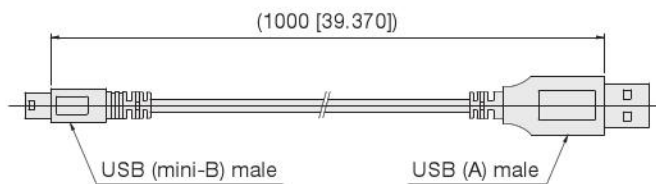
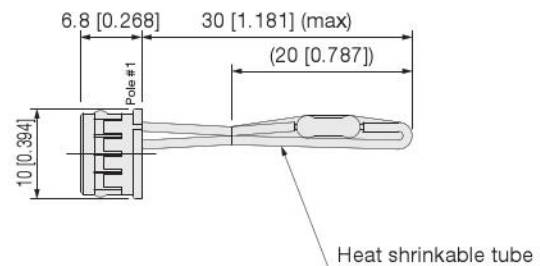

• Relay cable (loose wire) for main unit* (robot cable)

EW2KBA- □

015L: 150 mm [5.906 in.]
025L: 250 mm [9.843 in.]

Main unit side connector

NO.	Parts	Color
1	U	Green
2	V	Brown
3	W	Yellow
4	Vcc	Orange
5	HU	White
6	HV	Red
7	HW	Black
8	GND	Blue

Cable shield

Cable wire chart

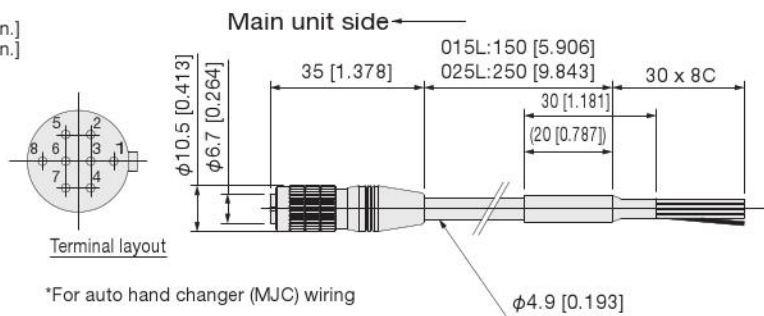

Terminal layout

*For auto hand changer (MJC) wiring

• Relay cable (loose wire) for controller* (robot cable)

EW2KBB- □

3L: 3 m [9.843 ft.]
5L: 5 m [16.404 ft.]

Controller side connector

NO.	Parts	Color
A1	U	Green
B1	V	Brown
A2	W	Yellow
B2	FG	Shield
A3	Vcc	Orange
B3	GND	Blue
A4	HU	White
B4	HV	Red
A5	HW	Black
B5	N.C.	-

Cable shield

Cable wire chart

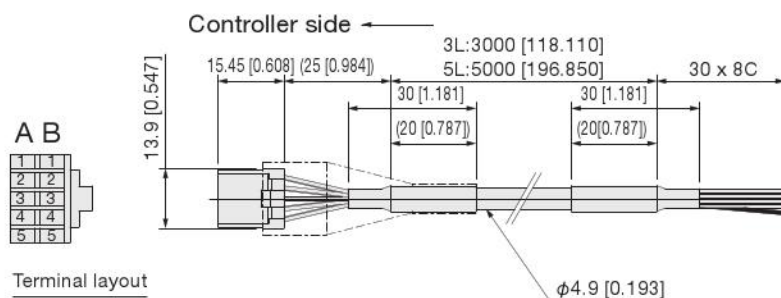

Terminal layout

*For auto hand changer (MJC) wiring

Teaching Box

EW2TB



Specifications

Item	Type	EW2TB
Power supply	Power supply voltage	DC 24 V (supplied from controller)
	Consumption current	50mA MAX.
Indication	Setting display	LCD 16 characters x 2 lines
	Power supply indication	LED lit when power turned ON (internal 5 V)
General	Setting method	Key operation: 8 buttons
	Communication method	RS485 (serial communication)
	Cable length	3 m [9.843 ft.]
	Mass	Main unit: 200 g [7.055 oz.]
	Operating temperature	0 to 40 °C [32 to 104°F]
	Operating humidity	35 to 80 % RH (without condensation)
	Storage temperature	-10 to 65 °C [14 to 149°F]

Teaching box dimensions mm [in.]

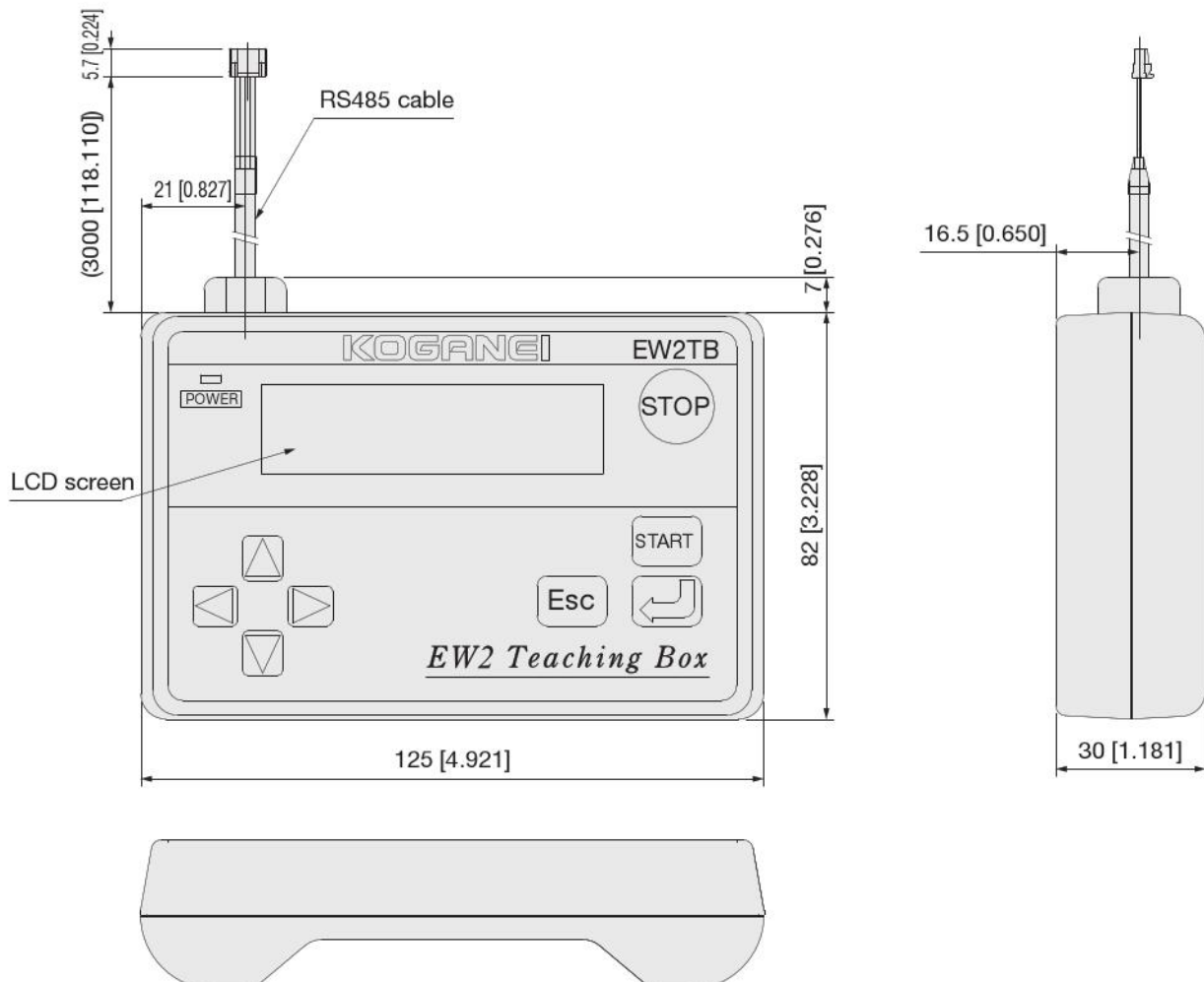

Selection guidelines

● System configuration of electric hand flat type (example)

● Point input type controller

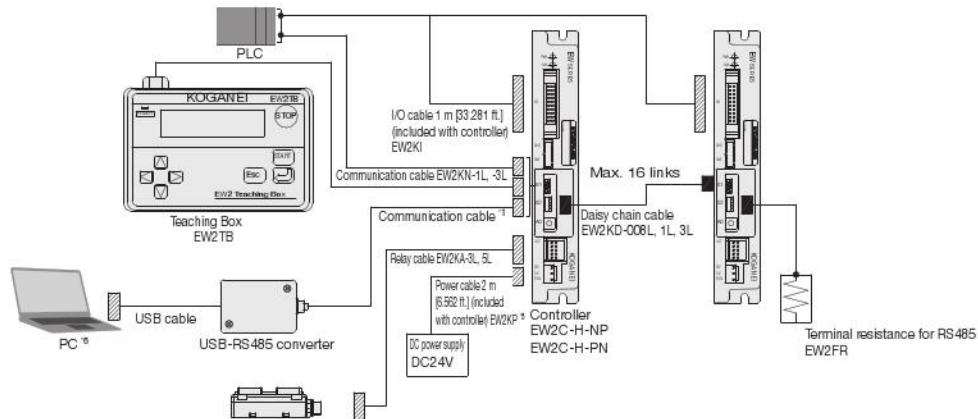

● CC-Link type controller (1)

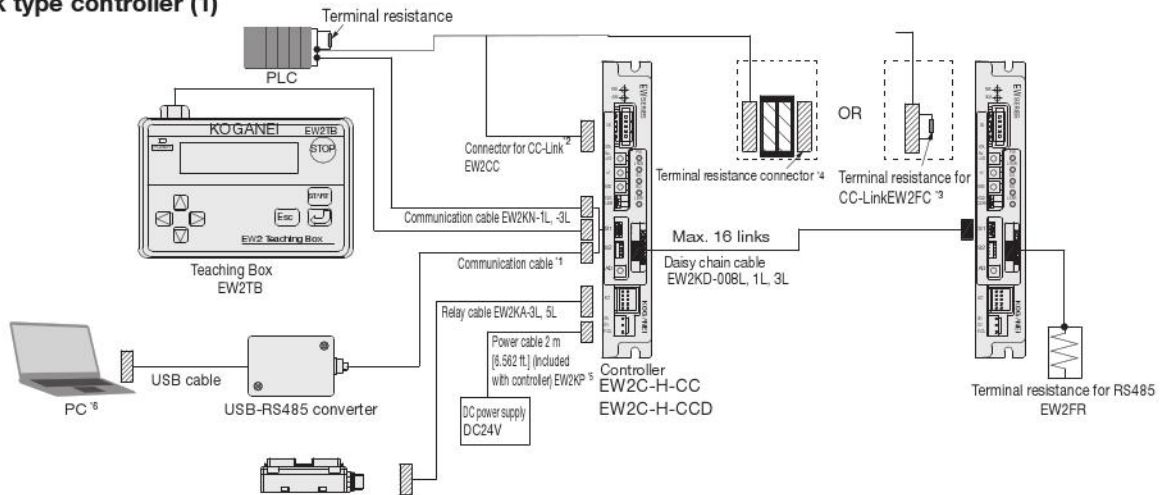

● CC-Link type controller (2)

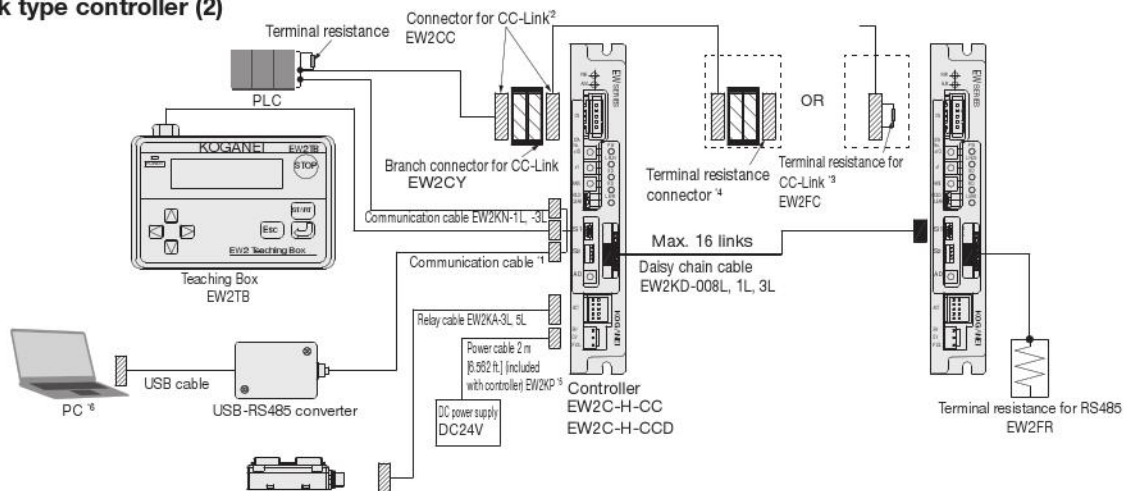

*1 One of the following communication cables can be selected.

- IBM2A-H1: USB-RS485 converter, with USB cable
- IBM2A-H1-N: USB-RS485 converter, without USB cable
- EW2KN: For communication

*2 Only the connector for CC-Link is provided. The cable must be provided by the customer. (Dedicated CC-Link cable supporting Ver1.1)

*3 When the EW2C-H-CC will be the end unit, make sure to use the terminal resistance for CC-Link (EW2FC) or terminal resistance connector.

*4 The terminal resistance connector must be provided by the customer.
[Recommended] 35T05-6M00-B0M GF from 3M

*5 The installation of a noise filter is recommended. (see page 10)

*6 The support software for setting the controller can be downloaded from the KOGANEI website free of charge.

Selection guidelines

● Grip point gripping force limitation

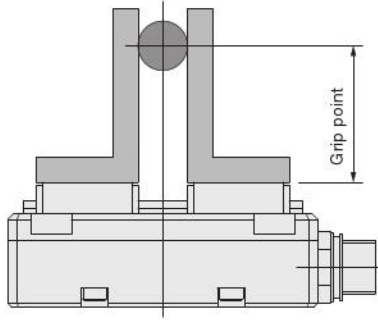

● Grip point and gripping force graph

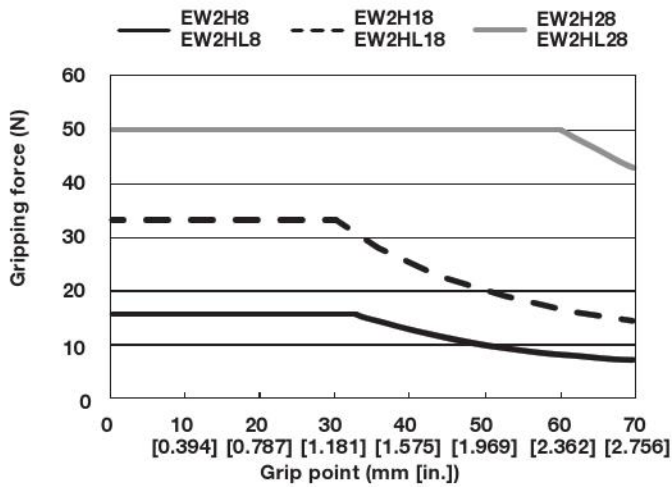

*Indicates the grip point of the maximum gripping force for each size. Set a grip point at or below the allowable moment (Mp).

● Allowable load and static allowable moment

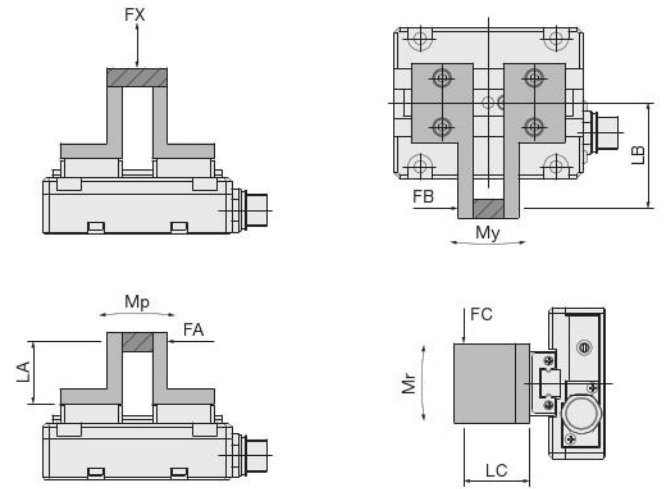

- $M_p = F_A \times L_A$ (N·m [in·lbf])
- $M_y = F_B \times L_B$ (N·m [in·lbf])
- $M_r = F_C \times L_C$ (N·m [in·lbf])

[Electric hand flat type]

Load and moment	FX	Mp	My	Mr
Type	N	N·m [in·lbf]	N·m [in·lbf]	N·m [in·lbf]
EW2 □ 8	40	0.5 [4.4]	0.3 [2.7]	0.6 [5.3]
EW2 □ 18	120	1.0 [8.9]	1.0 [8.9]	2.0 [17.7]
EW2 □ 28	190	3.0 [26.6]	4.0 [35.4]	8.0 [70.8]

Selection guidelines

● Gripping force specifications

EW2H8

EW2HL8 Gripping level ⇔ gripping force

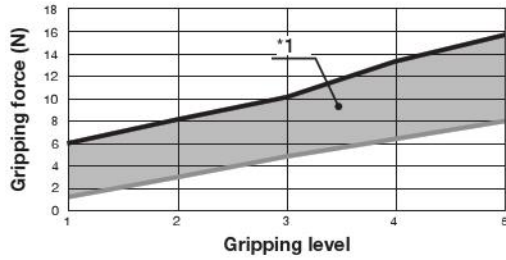

Gripping level ⇔ available speed range

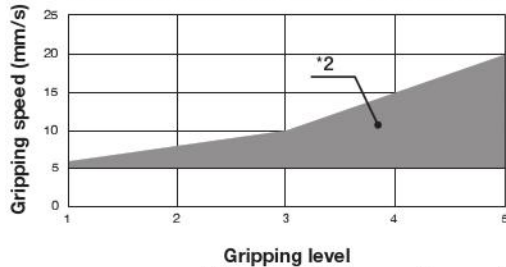

*The above gripping graph is an estimate.

EW2H18

EW2HL18 Gripping level ⇔ gripping force

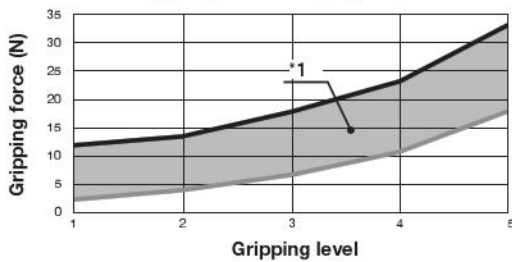

Gripping level ⇔ available speed range

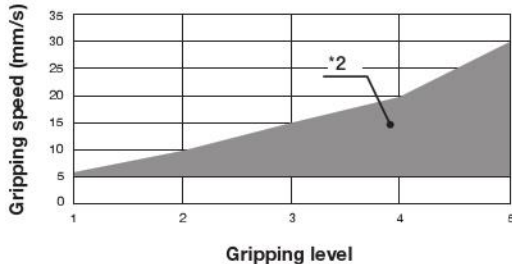

*The above gripping graph is an estimate.

EW2H28

EW2HL28 Gripping level ⇔ gripping force

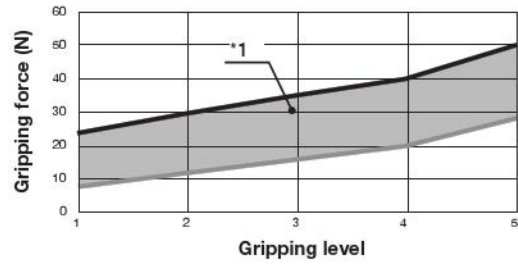

Gripping level ⇔ available speed range

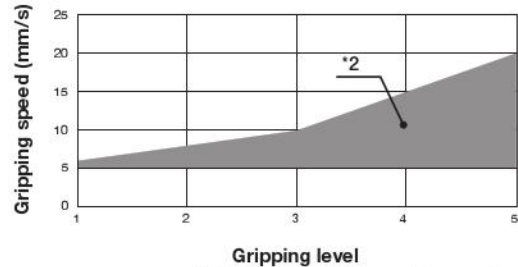

*The above gripping graph is an estimate.

- *1 Force is generated within the graph range at the set gripping level.
- *2 The gripping speed can be set within the graph range at the set gripping level.

● Electric hand operation mode

Mode	Positioning		Gripping ¹		Pushing with acceleration/deceleration movement Perform acceleration/deceleration movement and add pushing operation.
	Acceleration or deceleration is performed and movement is stopped at the specified point.		C	O	
Setting value	A	I ²	C	O	U
Description	Move to the position of the specified point with the coordinates of 0 as the origin position	Move to the position of the specified point from the current position	Operate to close side	Operate to open side	Move to the specified point and perform pushing operation at the speed of PRM7 from the distance before the point specified at PRM8
Operation pattern					
Remarks	—		—		Suitable for high-frequency soft gripping.

¹ Do not use C to O, or O to C motion in gripping mode as it will result in malfunction.

² When operation is performed in mode I after changing the position manually, the reference position is that before changing the position manually.

³ Perform workpiece gripping in the gripping mode (C, O) or pushing mode (U) with acceleration/deceleration movement.

When a workpiece is gripped with the positioning mode (A, I), an alarm is output and gripping cannot be performed normally.

Electric hand

Standard type



Specifications

Main unit basic specifications

Item	Type	EWHA12A	EWHA24A	EWHA36A
Motor		Two phase stepping motor		
Maximum speed (one side, when using positioning mode)	mm/s [in./sec]	70 [2.756]	35 [1.378]	24 [0.945]
Maximum speed (one side, when using gripping mode)	mm/s [in./sec]	35 [1.378]	10 [0.394]	10 [0.394]
Minimum speed (one side)	mm/s [in./sec]	1 [0.039]		
Maximum gripping force ¹	N	12 to 17	22 to 35	33 to 47
Operating temperature range	°C [°F]	0 to 40 [32 to 104]		
Open/closed stroke	mm [in.]	14 [0.551] (7 mm [0.276 in.] on one side)	20 [0.787] (10 mm [0.394 in.] on one side)	
Repeated positioning precision	mm [in.]	±0.03 [0.001]	±0.05 [0.002]	
Dynamic allowable moment ²	Mp N·m [in·lbf]	0.05 [0.4]	0.1 [0.9]	
	My N·m [in·lbf]	0.03 [0.3]	0.1 [0.9]	
	Mr N·m [in·lbf]	0.06 [0.5]	0.2 [1.8]	
Maximum payload (one side) ³	kg [lb]	0.3 (0.15) [0.661 (0.331)]	0.5 (0.25) [1.102 (0.551)]	
Mass	kg [lb]	0.17 [0.375]	0.26 [0.573]	
Applicable controllers		EWHC-NH, EWHCP-NH		

*1 The maximum gripping force at gripping level 10. For details on the gripping force and gripping speed, see the graph on page 40.

*2 The dynamic allowable moment is safety coefficient 10 to the allowable moment (page 39). However, the value is not guaranteed.

*3 Total mass of both side claws mounted to table.

See pages 35 and 36 for the controller specifications.

Order Codes

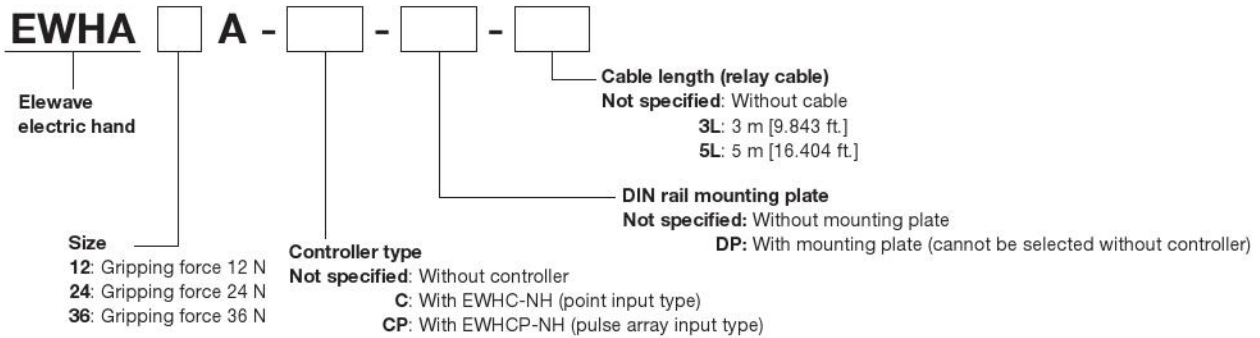

Additional parts

Point input type controller

- [Accessories]
 • Power cable
 • I/O cable



Cable (relay cable)*1
 *1 Robot cable

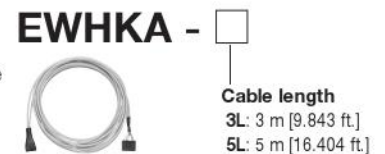

Pulse array input type controller

- [Accessories]
 • Power cable
 • I/O cable
 • Pulse array input cable
 • Conversion cable for pulse array input connector



Teaching² box



*2 See page 39 for the specifications and dimensions.

DIN rail mounting plate **EW2DP**



EWHA12A

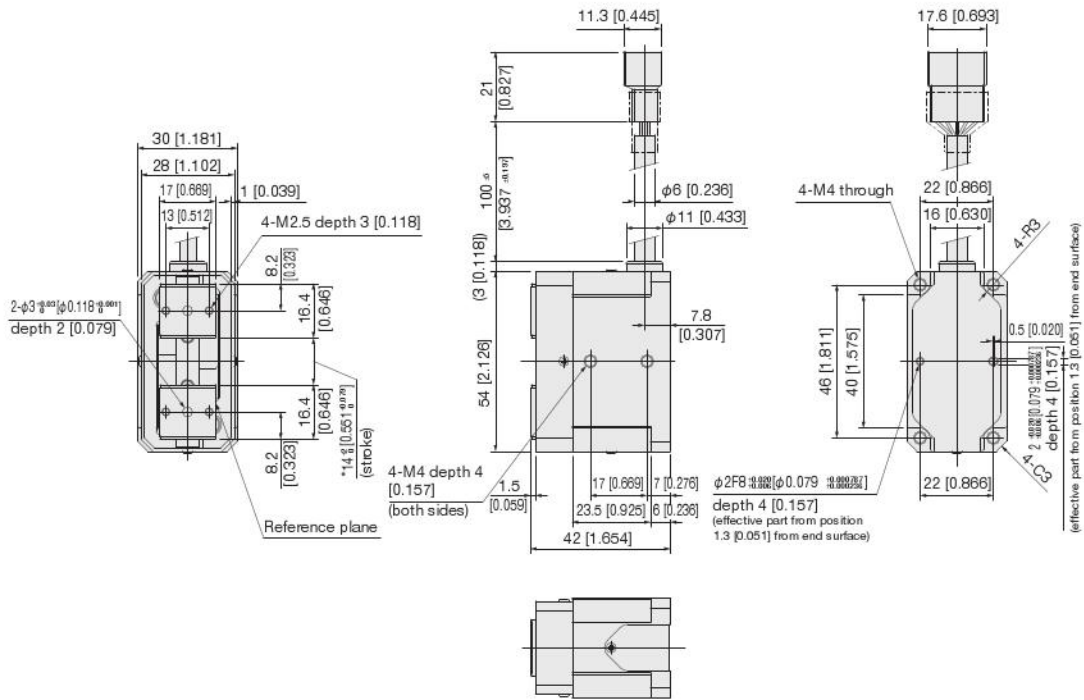

*Dimensions of the origin position on the open side. Use the origin shift function when it is necessary to adjust the origin position.

EWHA24A
EWHA36A

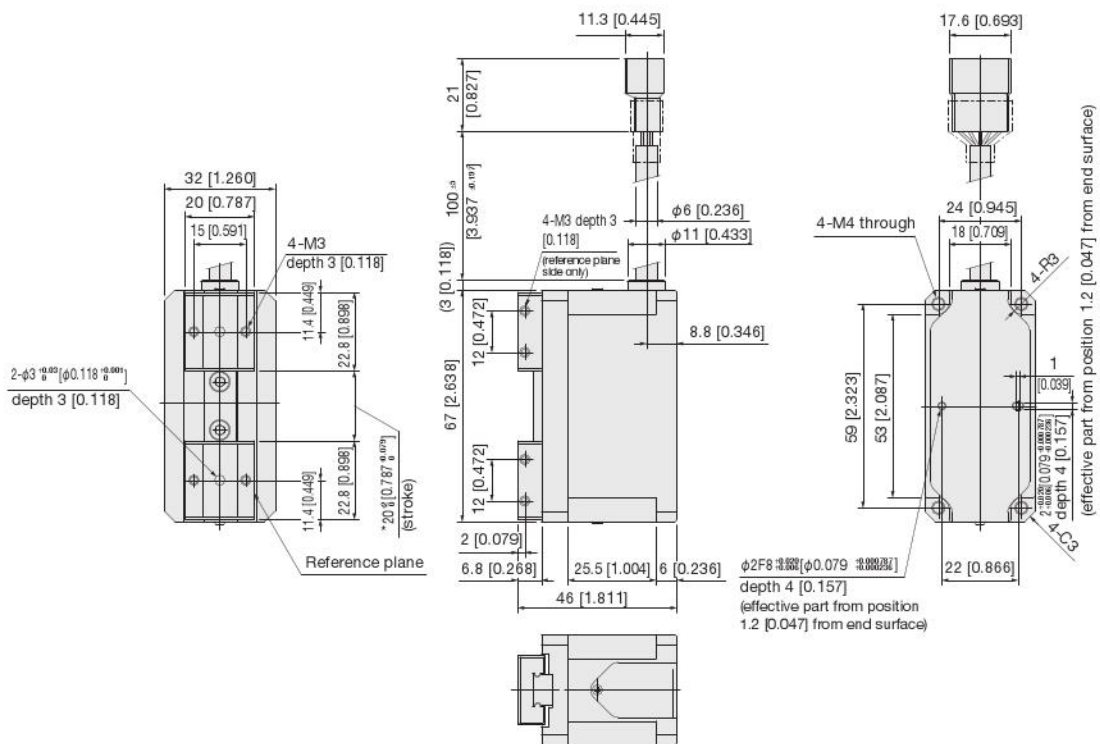

*Dimensions of the origin position on the open side. Use the origin shift function when it is necessary to adjust the origin position.

EW2H

EW2HL

EWHA □ A

EWHA □ H

EWHRT

EWMS

Material

Electric hand

High-speed type



Specifications

Main unit basic specifications

Item	Type	EWHA6H	EWHA12H	EWHA24H	EWHA36H
Motor		Two phase stepping motor			
Maximum speed (one side, when using positioning mode)	mm/s [in./sec]	140 [5.512]	180 [7.087]	120 [4.724]	100 [3.937]
Maximum speed (one side, when using gripping mode)	mm/s [in./sec]	50 [1.969]	35 (10) [1.378 (0.394)] ^{*1}	20 [0.787]	10 [0.394]
Minimum speed	mm/s [in./sec]	1 [0.039]			
Maximum gripping force ²	N	5 to 9	11 to 16	22 to 32	34 to 46
Operating temperature range	°C [°F]	0 to 40 [32 to 104]			
Open/closed stroke	mm [in.]	14 [0.551] (7 mm [0.276 in.] on one side)	22 [0.866] (11 mm [0.433 in.] on one side)	26 [1.024] (13 mm [0.512 in.] on one side)	
Repeated positioning precision	mm [in.]	±0.03 [0.001]		±0.05 [0.002]	
Dynamic allowable moment ³	Mp N·m [in·lbf]	0.03 [0.3]	0.06 [0.5]	0.09 [0.8]	
	My N·m [in·lbf]	0.03 [0.3]	0.05 [0.4]	0.08 [0.7]	
	Mr N·m [in·lbf]	0.05 [0.4]	0.13 [1.2]	0.22 [1.9]	
Maximum payload (one side) ⁴	kg [lb]	0.2 (0.1) [0.441 (0.220)]	0.3 (0.15) [0.661 (0.331)]	0.5 (0.25) [1.102 (0.551)]	
Mass	kg [lb]	0.15 [0.331]	0.29 [0.639]	0.35 [0.772]	0.36 [0.794]
Applicable controllers		EWHC-NH, EWHCP-NH			

*1 The maximum speed of the EWHA12H at gripping level 1 to 5 is 10 mm/s [0.394 in./sec].

*2 The maximum gripping force at gripping level 10. For details on the gripping force and gripping speed, see the graph on page 40.

*3 The dynamic allowable moment is safety coefficient 10 to the allowable moment (page 39). However, the value is not guaranteed.

*4 Total mass of both side claws mounted to table.

See pages 35 and 36 for the controller specifications.

Order Codes

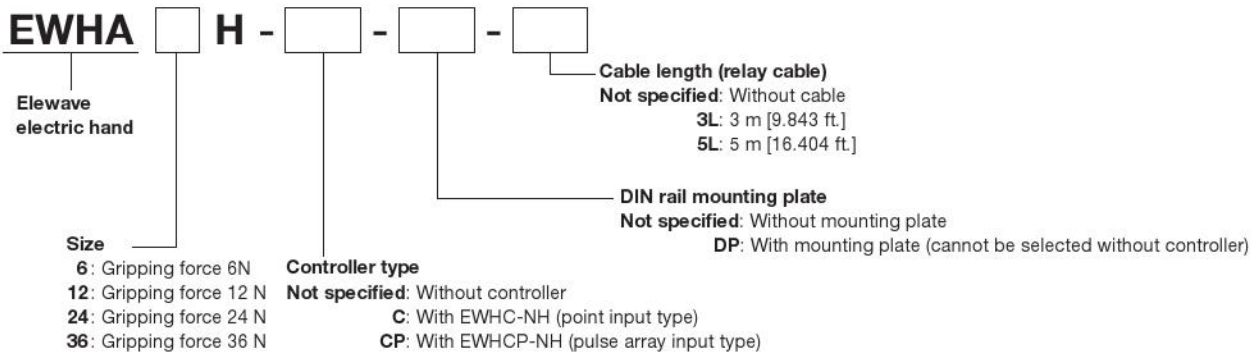

Additional parts

Point input type controller

- [Accessories]
- Power cable
 - I/O cable



Cable (relay cable)^{*1}

*1 Robot cable

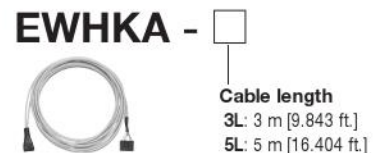

Pulse array input type Controller

- [Accessories]
- Power cable
 - I/O cable
 - Pulse array input cable
 - Conversion cable for pulse array input connector



Teaching² box



*2 See page 59 for the specifications and dimensions.

DIN rail mounting plate



EWHA6H

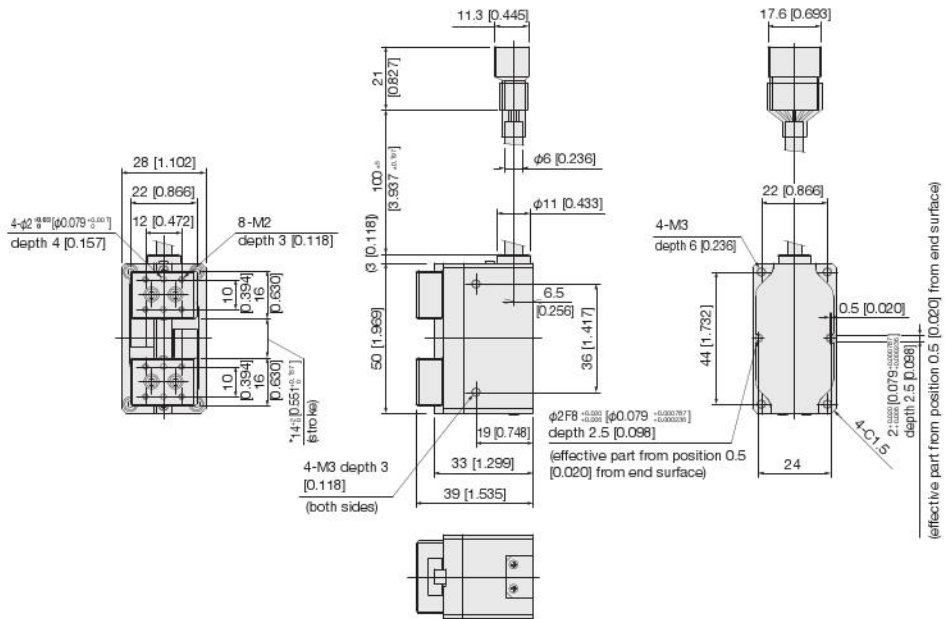

EWHA12H

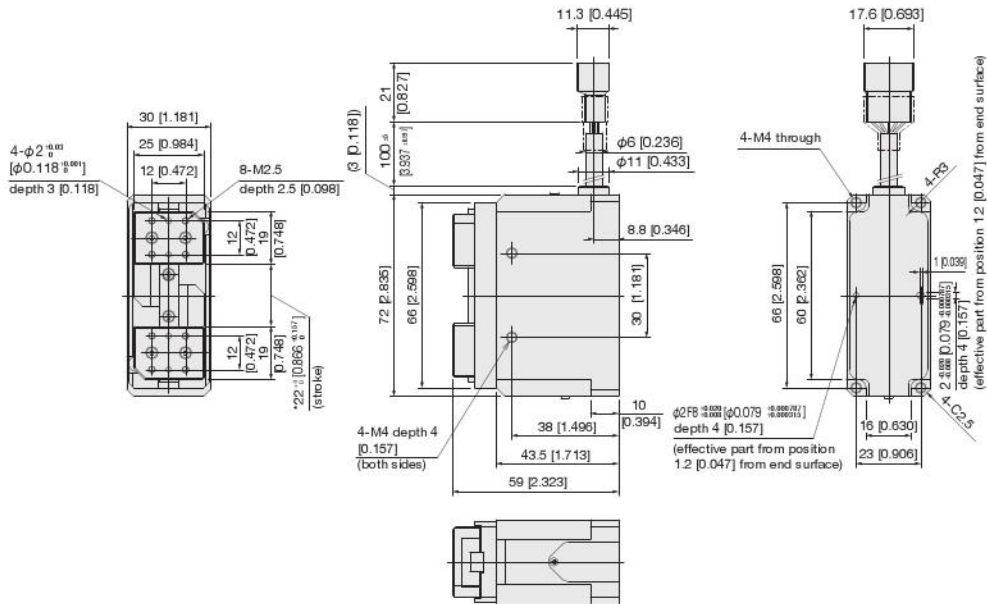

EWHA24H
EWHA36H

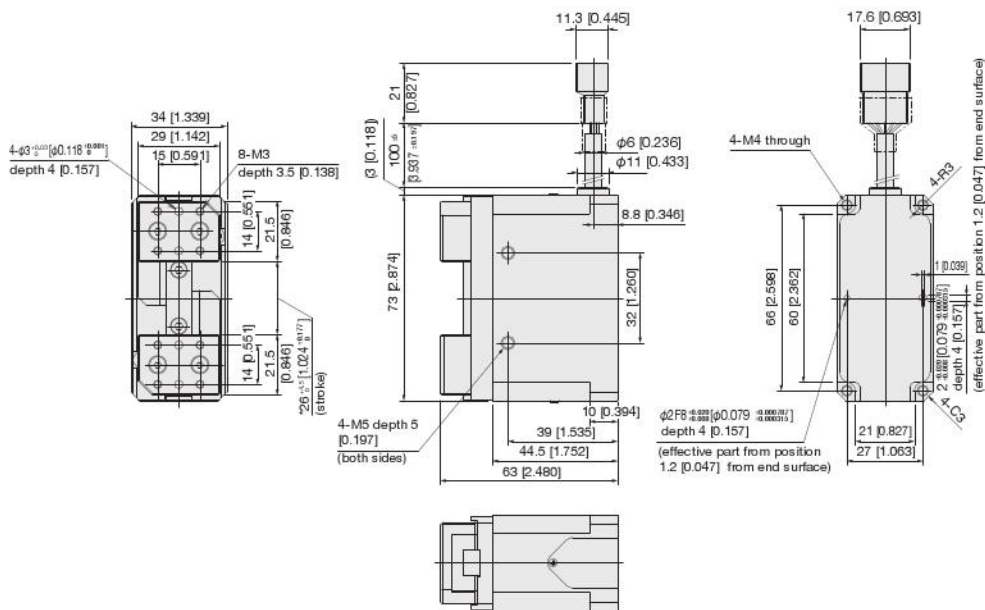

*Dimensions of the origin position on the open side. Use the origin shift function when it is necessary to adjust the origin position.

Controller

Point input type



Specifications

Item	Type	EWHC-NH
Axis control	Motor drive system	Microstep drive
	Control method	Closed loop control ¹
	Operating method	PTP, force control
	Origin detection method	Stroke end detection
	Position detection method	Encoder A/B phase output
	Minimum setting distance (angle)	0.01 mm [0.0003 in.]
	Acceleration setting	1 to 100 %
	Point setting	64 points
	Point input method	Numeric input, teaching input, direct teaching
External input/output	Point setting input	6 point (POS0~POS5) photocoupler receptor 5 mA TYP/point
	Control input	3 point (ORG, START, STOP) photocoupler receptor 5 mA TYP/point
	Control output	4 point (READY, BUSY, HOLD, INPOS) 30 mA Max./point
	Error detection output	Overload, wiring disconnection, data error, system error
	External communication	RS232C 1 ch (computer, TB communication)
	Motor drive output	Dedicated cable (with F.G.)
	Encoder input	Dedicated cable (shielded)
General specifications	Mass	0.2 kg [0.441 lb]
	Power supply	DC 24 V±10 % 1.0 A Max. (motor, I/O power supply shared) ²
	Operating temperature	0 to 40 °C [32 to 104°F]
	Operating humidity	35 to 85 % RH (without condensation)
	Storage temperature	-10 to 65 °C [14 to 149°F]
	Backup	Setting conditions retained in EEPROM
	Noise resistance	IEC61000-4-4 level 3
	Accessories	I/O cable, power cable

¹ Missed step detection and force control when gripping are performed via a rotary encoder.

² The maximum consumption current value differs according to the actuator. See the table below.

Maximum consumption current (electric hand)

(A)

Model	EW5□	EWHA12A	EWHA24A	EWHA36A	EWHA6H	EWHA12H	EWHA24H	EWHA36H
Maximum consumption current	0.6					1.0		

Controller Wiring Method

1. When using the internal power supply of the controller (electric hand)

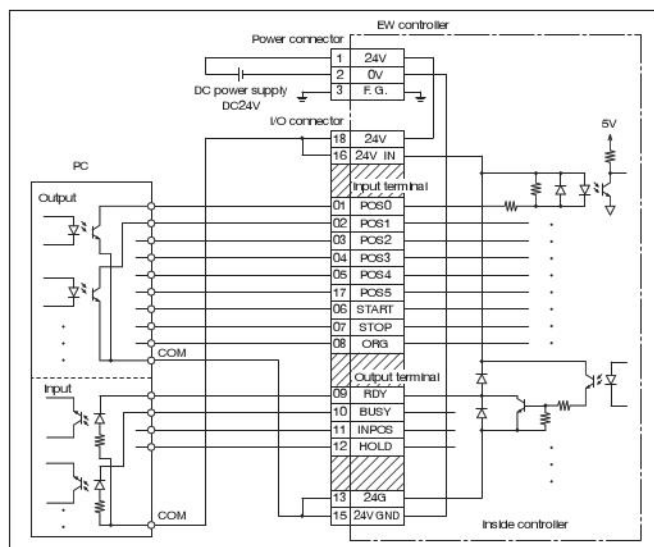

2. When not using the internal power supply of the controller (electric hand)

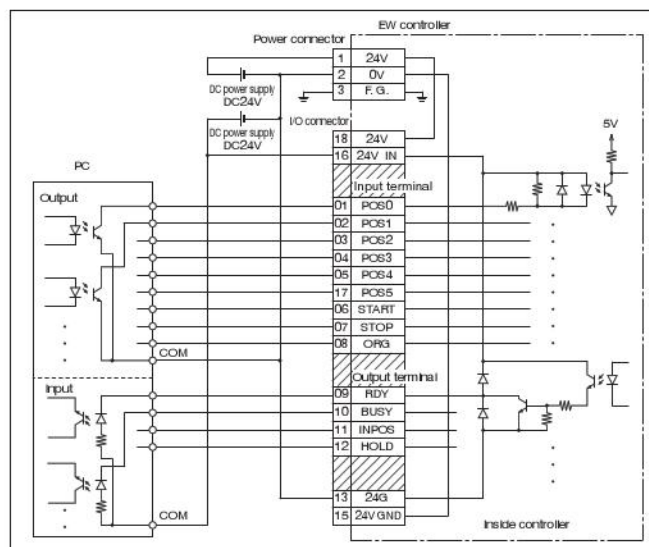

Controller

Pulse array input type



EW2H

EW2HL

EWHA □ A

EWHA □ H

EWHR

EWM5

Material

Specifications

Item	Type	EWHCP-NH
Axis control	Motor drive system	Microstep drive
	Control method	Closed loop control ¹
	Operating method	Position control and force control via pulse array input
	Origin detection method	Stroke end detection
	Position detection method	Encoder A/B phase output
	Pulse array input method	Differential line driver/open collector
	Maximum input pulse frequency ²	Max. 200 kpps (differential line driver)/Max. 60 kpps (open collector)
	Pulse array input instruction format	CW/CCW, pulse/code (positive/negative logic available)
External input/output	Control input	6 points (alarm reset, clear counter, pushing mode transfer, servo ON, pulse input prohibited/origin return stopped, origin return) 5 mA TYP/point
	Control output	4 points (preparations complete, pulse input reception available, positioning complete/pushing operation complete, zone output) 30 mA Max./point
	Error detection output	Overload, data error, system error
	External communication	RS232C 1 ch (computer, TB communication)
	Motor drive output	Dedicated cable (with F.G.)
	Encoder input	Dedicated cable (shielded)
	Pulse array input	Dedicated cable (twisted pair cable)
General specifications	Mass	0.2 kg [0.441 lb]
	Power supply	DC 24 V±10 % 1.0 A max. (motor, I/O power supply shared) ³
	Operating temperature	0 to 40 °C [32 to 104°F]
	Operating humidity	35 to 85 % RH (without condensation)
	Storage temperature	-10 to 65 °C [14 to 149°F]
	Backup	Setting conditions retained in EEPROM
	Noise resistance	IEC61000-4-4 level 3
	Accessories	I/O cable, power cable, pulse array input cable ⁴ , conversion cable for pulse array input connector x 2 ⁵

¹ Missed step detection and force control when gripping are performed via a rotary encoder.

² The actual maximum input pulse count is regulated by the maximum speed of each actuator.

³ The maximum consumption current value differs according to the actuator. See the table below.

⁴ The length of the pulse array input cable is 1 m [3.281 ft.].

⁵ Note that the method for connecting the pulse array input cable differs for the differential line driver input and open collector input (see the instruction manual for details).

Maximum consumption current (NS slider, electric hand)

(A)

Model	EWM5 □	EWHA12A	EWHA24A	EWHA36A	EWHA6H	EWHA12H	EWHA24H	EWHA36H
Maximum consumption current	0.6	0.6			1.0		1.0	

Controller Wiring Method

1. When using the internal power supply of the controller (electric hand)

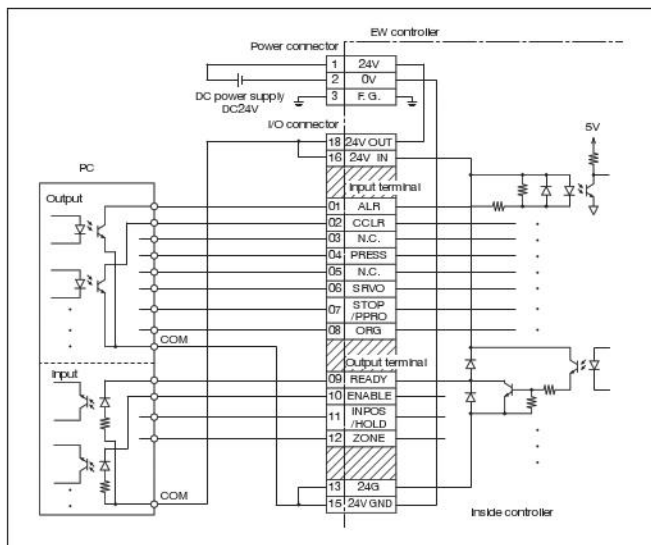

2. When not using the internal power supply of the controller (electric hand)

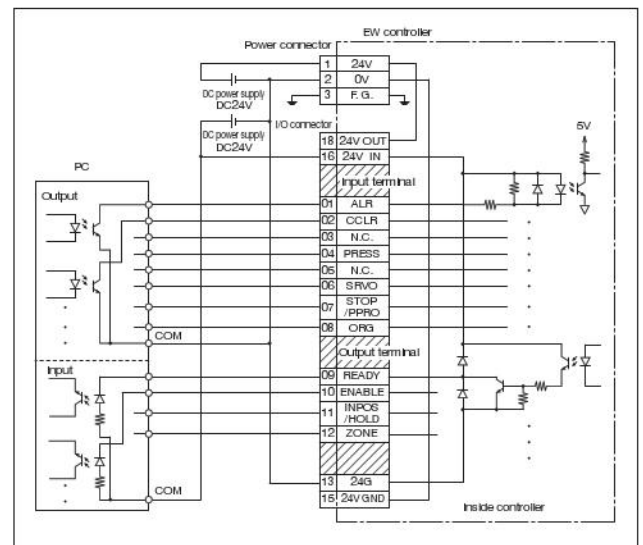

Controller dimensions mm [in.]

(point input type)

EWHC-NH - 

DIN rail mounting plate
 Not specified: Without
 DP: With (cannot be selected without controller)

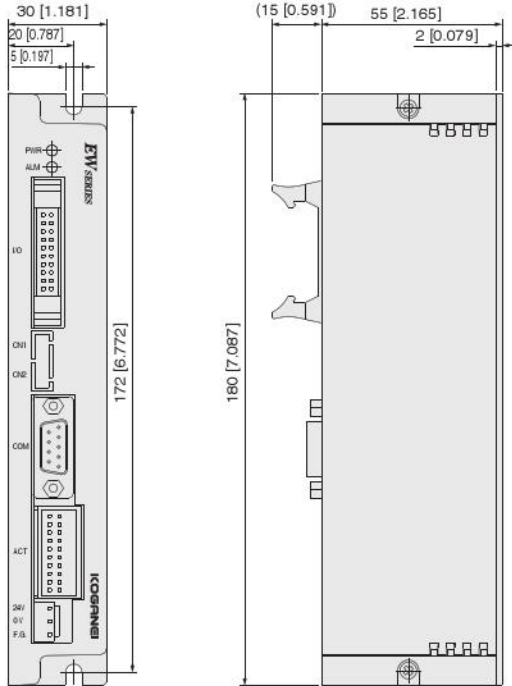

(pulse array input type)

EWHCP-NH - 

DIN rail mounting plate
 Not specified: Without
 DP: With (cannot be selected without controller)

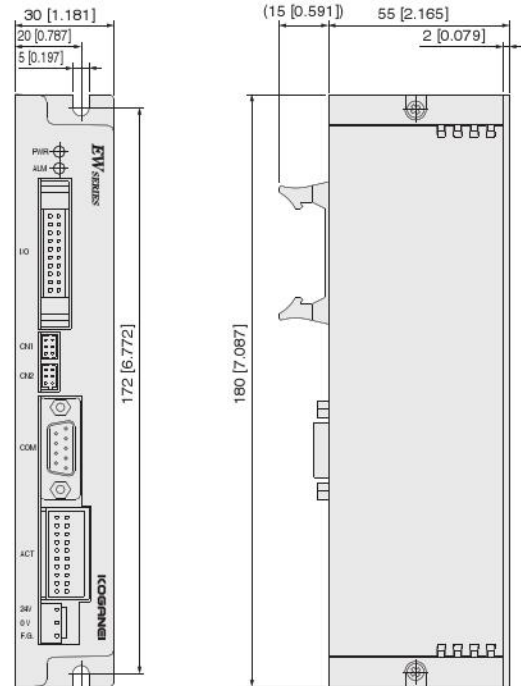

Controller dimensions mm [in.]

● DIN rail mounting plate

EW2DP

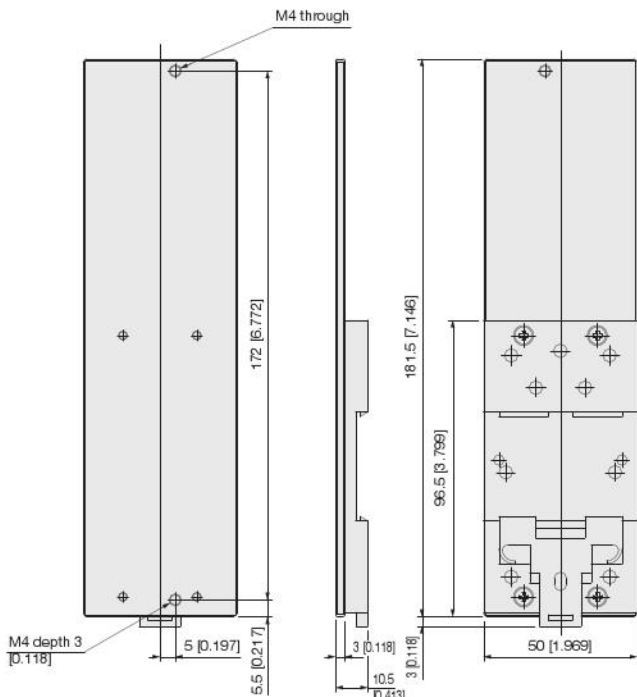
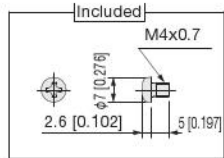

Controller wiring method (pulse array input type)

● Differential line driver input circuit

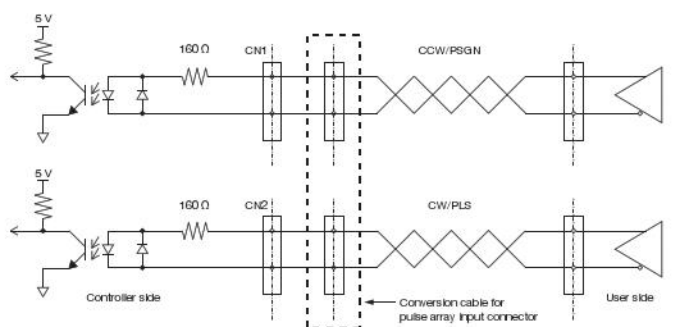

● Open collector input circuit

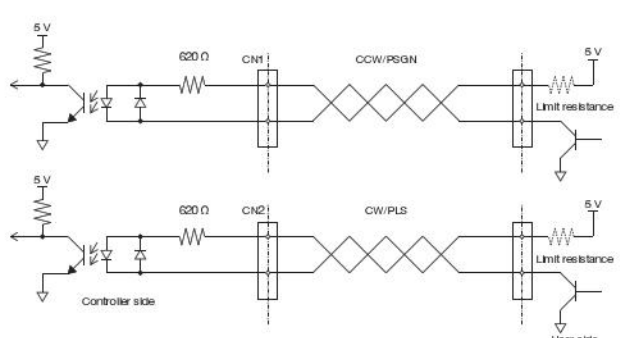

[Caution] When applying voltage of 5.5 V or higher, add current limit resistance (10 mA or less).

Controller dimensions mm [in.]

● Controller included

• I/O cable

EW2KI

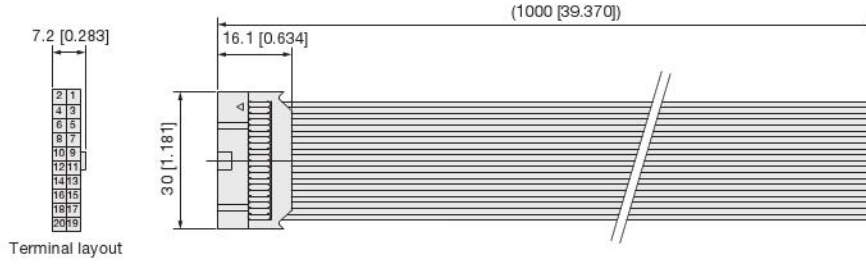

Terminal layout

• Power cable

EW2KP

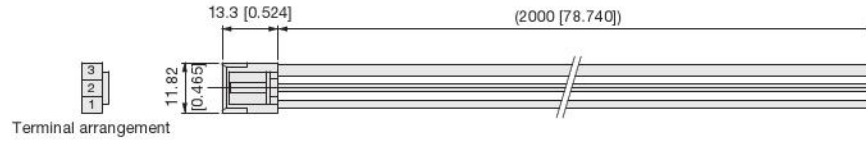

Terminal arrangement

• Pulse array input cable (pulse array input type controller only)

EWHKY

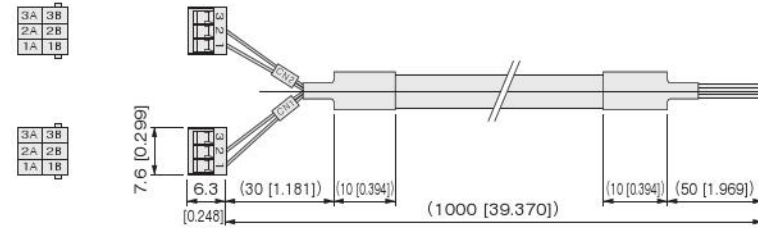

• Conversion cable for pulse array input connector (pulse array input type controller only)

*Make sure to use this conversion cable when the pulse array input signal is a differential line driver.

EWHKC



● Cable

• Relay cable (robot cable)

EWHKA-

3L: 3 m [9.843 ft.]
5L: 5 m [16.404 ft.]

3L-3000 [118.110]
5L-5000 [196.850]

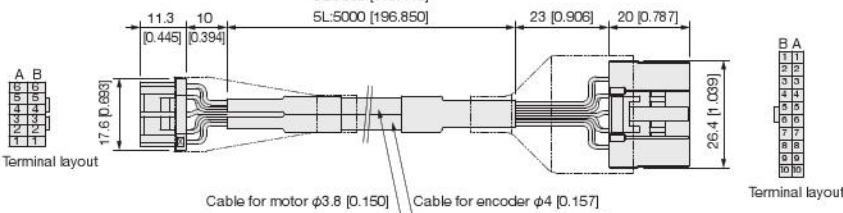

Terminal layout

Terminal layout

Cable for motor $\phi 3.8$ [0.150] Cable for encoder $\phi 4$ [0.157]

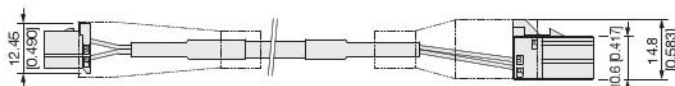

Main unit side connector

No.	Parts	Color
A1	F.G.	Brown
A2	A+	Red
A3	A-	Yellow
A4	B+	Green
A5	B-	White
A6	BRK	Black
B1	Shield	
B2	GND	Red
B3	5V	Yellow
B4	EA	Green
B5	EB	White
B6	EC	Black

Controller side connector

No.	Parts	Color
A1	A+	Red
B1	B+	Green
A2	A-	Yellow
B2	B-	White
A3	F.G.	Brown
B3	BRK	Black
A4	COM1	—
B4	COM2	—
A5		—
B5		—
A6	F.G.	—
B6	GND 5V	—
A7	DV+	Yellow
B7	DV-	Red
A8	EA+	—
B8	EA-	Green
A9	EB+	—
B9	EB-	White
A10	EC+	—
B10	EC-	Black

Selection guidelines

- Electric hand
- Grip point gripping force limitation

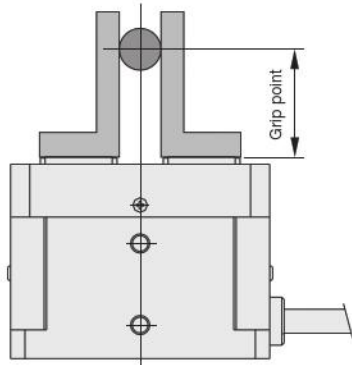

- Grip point and gripping force graph
[Standard type]

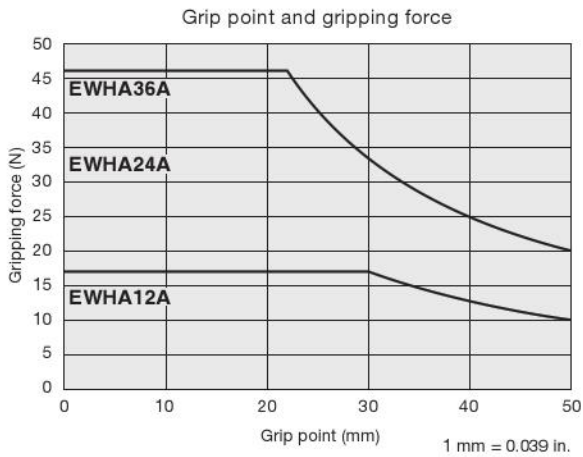

- [High-speed type]

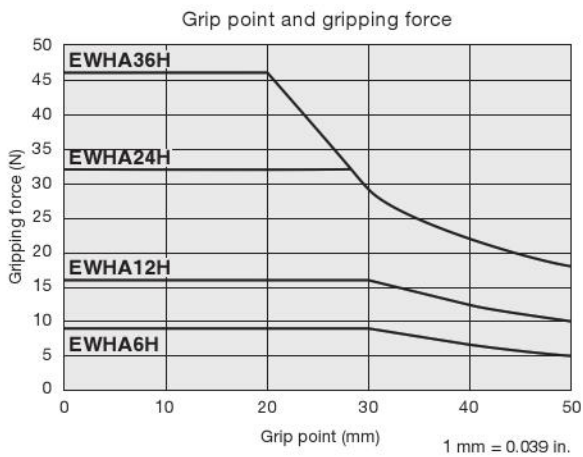

*Indicates the grip point of the maximum gripping force for each size. Set a grip point at or below the allowable moment (Mp).

- Allowable load and static allowable moment

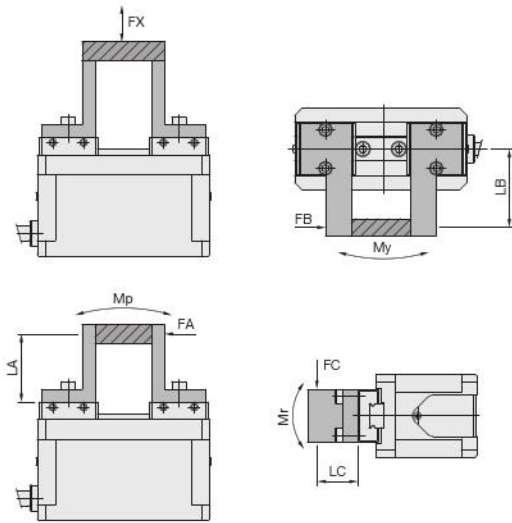

- $M_p = F_A \times L_A$ (N·m [in·lbf])
- $M = F_B \times L_B$ (N·m [in·lbf])
- $M_r = F_C \times L_C$ (N·m [in·lbf])

- [Standard type]

Type	Load and moment	FX N	Mp N·m [in·lbf]	My N·m [in·lbf]	Mr N·m [in·lbf]
EWHA12A		40	0.51 [4.5]	0.3 [2.7]	0.6 [5.3]
EWHA24A EWHA36A		120	1.0 [8.9]	1.0 [8.9]	2.0 [17.7]

- [High-speed type]

Type	Load and moment	FX N	Mp N·m [in·lbf]	My N·m [in·lbf]	Mr N·m [in·lbf]
EWHA6H		59	0.26 [2.3]	0.26 [2.3]	0.46 [4.1]
EWHA12H		118	0.57 [5.0]	0.48 [4.2]	1.29 [11.4]
EWHA24H EWHA36H		154	0.9 [8.0]	0.75 [6.6]	2.16 [19.1]

- System configuration (example)

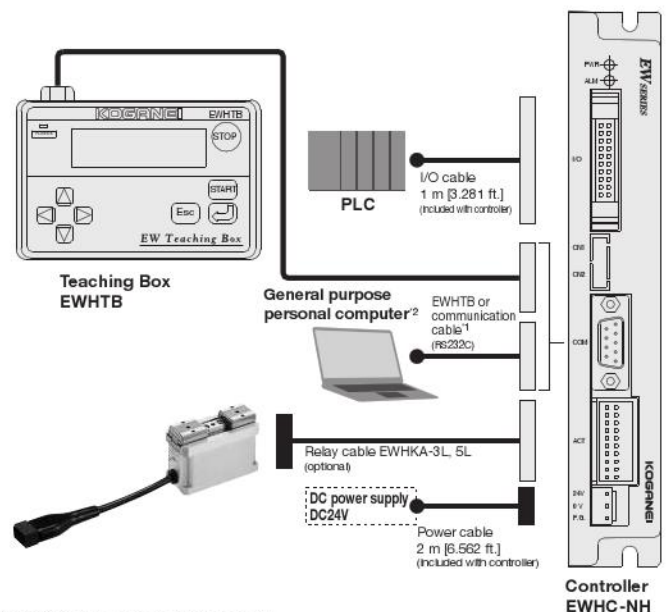

- *1 RS232C cable (for reference)

Specifications: D-sub 9 pin (female) ↔ D-sub 9 pin (female)/cross cable
Type: C232R-ECO915 (1.5 m [4.921 ft.])/C232R-ECO930 (3.0 m [9.843 ft.])
Manufacturer: Elecom Co., Ltd.

The communication cable must be provided by the customer.

- *2 The support software for setting the controller can be downloaded from the KOGANEI website free of charge.

Handling instructions and Precautions

● Gripping force range

Force is generated within the lower graph range at the set level. However, the gripping force repeat precision in the same position is within 5%.

[Standard type]

EWHA12A



EWHA24A

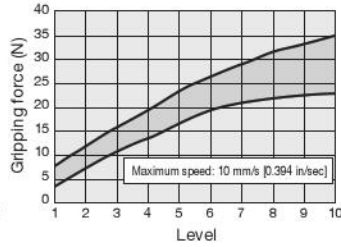

EWHA36A

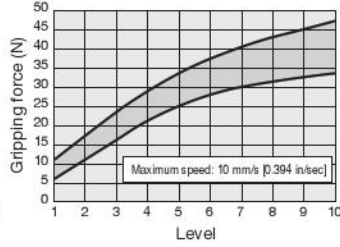

[High-speed type]

EWHA6H

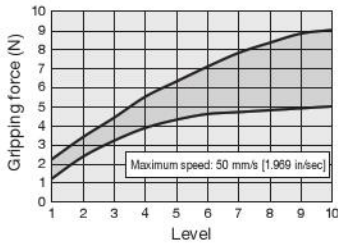

EWHA12H

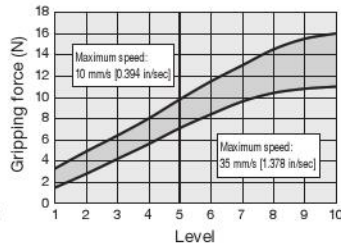

EWHA24H

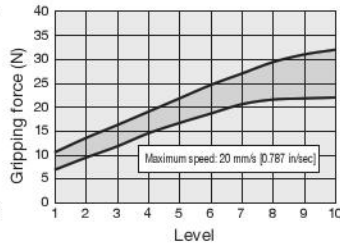

EWHA36H

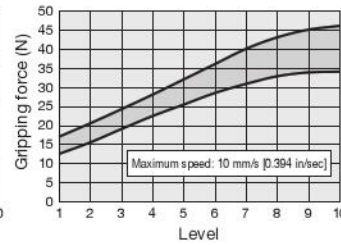

*The maximum speed up to level 5 is 10 mm/s [0.394 in/sec].

*The above gripping force range is an estimate.

● Electric hand operation mode (for the point input type controller)

Mode	Positioning		Gripping		Gripping with acceleration/deceleration movement
	Acceleration or deceleration is performed and movement is stopped at the specified point.		Perform operation at a constant speed and gripping at the set force.		Perform acceleration/deceleration movement and add gripping operation.
Setting value	A	I	C	O	U
Description	Move to the position of the specified point with the coordinates of 0 as the origin position	Move to the position of the specified point from the current position	Operate to close side	Operate to open side	Move to the specified point and perform gripping operation at the speed of PRM7 from the distance before the point specified at PRM8
Operation pattern					
Remarks	—		—		Suitable for high-frequency soft gripping.

*Do not use C to O, or O to C motion in gripping mode as it will result in malfunction.

EW2H

EW2HL

EWHA □ A

EWHA □ H

EWHR

EW5

Material

Electric rotary actuator



Specifications

Main unit basic specifications

Item	Type	EWHRT1A	EWHRT3A	EWHRT5A	EWHRT10A	EWHRT20A	EWHRT40A	EWHRT60A
Motor		Two phase stepping motor						
Maximum torque	N·m [in·lbf]	0.1 [0.9]	0.25 [2.2]	0.5 [4.4]	1.0 [8.9]	2.0 [17.7]	4.0 [35.4]	6.0 [53.1]
Repeated positioning precision ²	°	±0.02						
Angle detection		Optical encoder (with origin point)						
Maximum load inertia ³	kg·m ² [lb·ft ²]	3.0 x 10 ⁻⁴ [2.21 x 10 ⁻⁴]	1.0 x 10 ⁻³ [0.74 x 10 ⁻³]	3.0 x 10 ⁻³ [2.21 x 10 ⁻³]	2.0 x 10 ⁻³ [1.48 x 10 ⁻³]	2.0 x 10 ⁻² [1.48 x 10 ⁻²]	5.0 x 10 ⁻² [3.69 x 10 ⁻²]	1.0 x 10 ⁻¹ [0.74 x 10 ⁻¹]
Minimum operation time ⁴	(90° load free)	s	0.2	0.1	0.2	0.12	0.2	0.3
	(90° maximum load)	s	0.35	0.25	0.4	0.25	0.5	0.65
Minimum speed	rps	0.5	0.01					
Operating temperature range	°C [°F]	0 to 40 [32 to 104]						
Allowable thrust load	N	100		200		400		
Allowable radial load	N	100		200		400		
Allowable moment	N·m [in·lbf]	2.5 [22.1]		5.5 [48.7]		10.0 [88.5]		
Mass ⁵	kg [lb]	0.3 [0.661]	0.34 (0.4) [0.750 (0.882)]	0.8 (0.9) [1.764 (1.984)]		2.0 (2.3) [4.409 (5.071)]	2.2 (2.5) [4.850 (5.512)]	
Applicable controllers		EWHC-RS, EWHCP-RS		EWHC-RA, EWHCP-RA				

*1 EWHRT40A and EWHRT60A are the type where the cable does not protrude from the main unit (the connector is built into the side of the main unit).

*2 The repeated positioning precision for pulsation.

*3 The workpiece mass moment of inertia must be at or below the maximum load inertia.

*4 The value when there is no load torque.

*5 Values in parentheses are the mass with brake.

● See pages 45 and 46 for the controller specifications.

Order Codes

EWHRT **A** - - - - -

Elewave electric rotary actuator

Size

- 1 : Torque 0.1 N·m [0.9 in·lbf]
- 3 : Torque 0.25 N·m [2.2 in·lbf]
- 5 : Torque 0.5 N·m [4.4 in·lbf]
- 10 : Torque 1.0 N·m [8.9 in·lbf]
- 20 : Torque 2.0 N·m [17.7 in·lbf]
- 40 : Torque 4.0 N·m [35.4 in·lbf]
- 60 : Torque 6.0 N·m [53.1 in·lbf]

Brake

Not specified: Without brake
B: With brake¹

Controller type

Not specified: Without controller
C: With EWHC-RA or EWHC-RS (point input type)
CP: With EWHCP-RA or EWHCP-RS (pulse array input type)

Cable length (relay cable)

Not specified: Without cable
3L: 3 m [9.843 ft.]
5L: 5 m [16.404 ft.]

DIN rail mounting plate

Not specified: Without mounting plate
DP: With mounting plate (cannot be selected without controller)

*1 There is no EWHRT1A with brake.

Additional parts

Point input type controller

- [Accessories]
- Power cable
 - I/O cable

EWHC - RA -



DIN rail mounting plate
Not specified: Without mounting plate
DP: With mounting plate

EWHC - RS - (for EWHRT1A)



DIN rail mounting plate
Not specified: Without mounting plate
DP: With mounting plate

Pulse array input type controller

- [Accessories]
- Power cable
 - I/O cable
 - Pulse array input cable
 - Conversion cable for pulse array input connector

EWHCP - RA -



DIN rail mounting plate
Not specified: Without mounting plate
DP: With mounting plate

EWHCP - RS - (for EWHRT1A)



DIN rail mounting plate
Not specified: Without mounting plate
DP: With mounting plate

DIN rail mounting plate

EW2DP



Cable (relay cable)²

² Robot cable

EWHKA -



Cable length
3L: 3 m [9.843 ft.]
5L: 5 m [16.404 ft.]

Teaching³ box

EWHTB



*3 See page 59 for the specifications and dimensions.

EWHRT1A

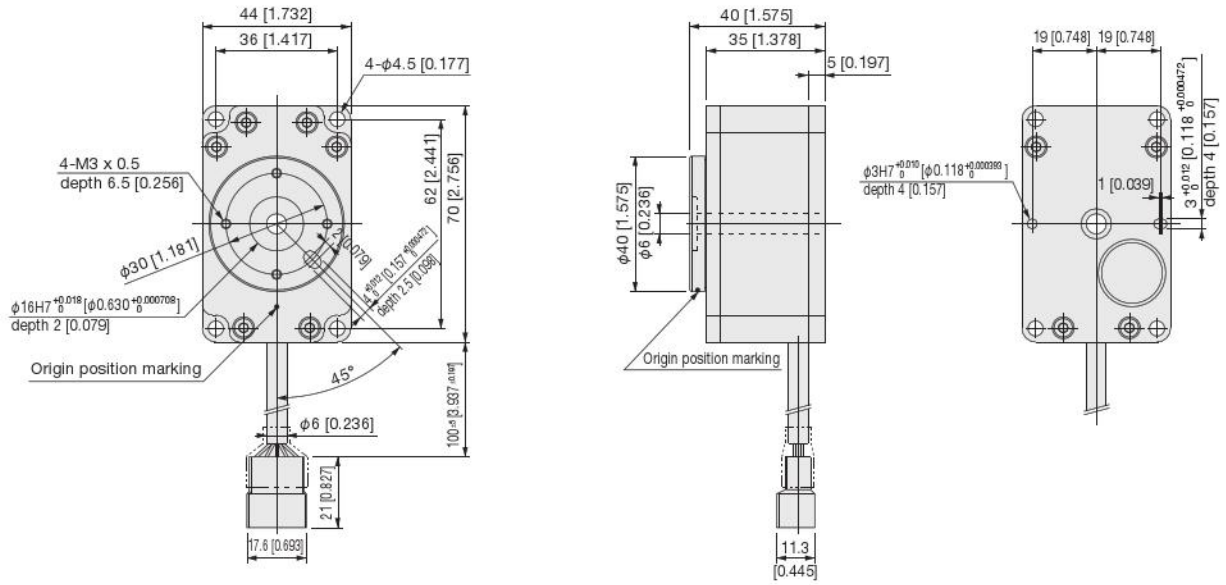

*The origin position of the table is when the slot of the locating dowel pin is in the position indicated in the figure above.

**EWHRT3A
EWHRT5A**

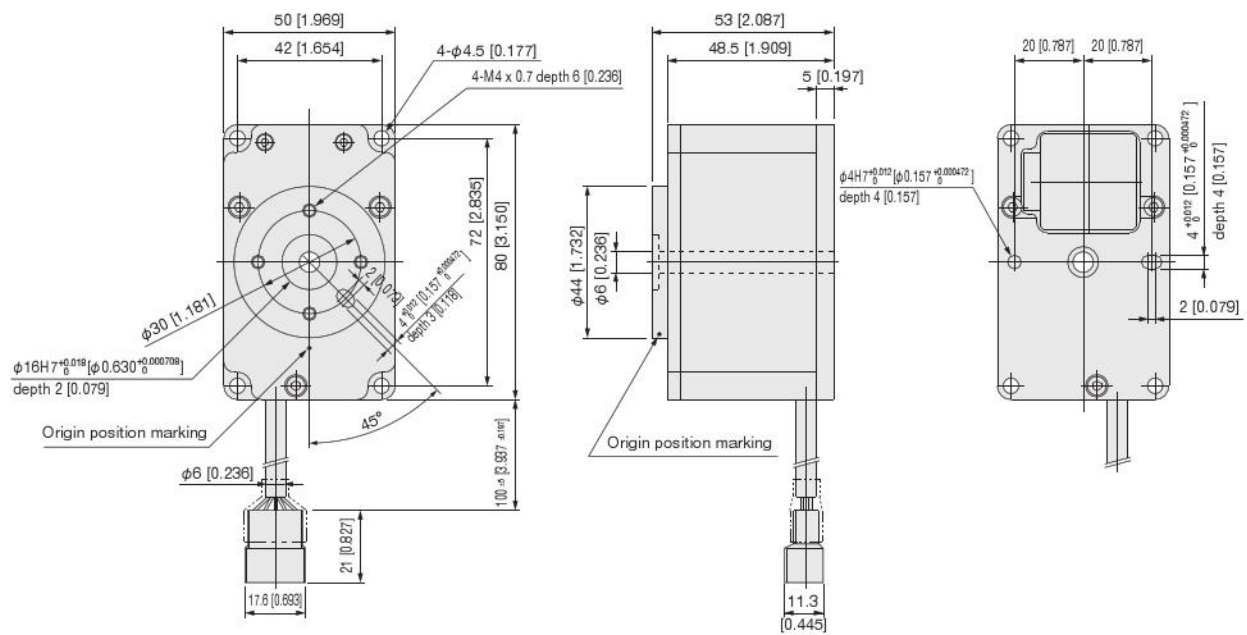

*The origin position of the table is when the slot of the locating dowel pin is in the position indicated in the figure above.

EW2H

EW2HL

EWHA □ A

EWHA □ H

EWHRT

EW5

Material

EWHRT10A
EWHRT20A

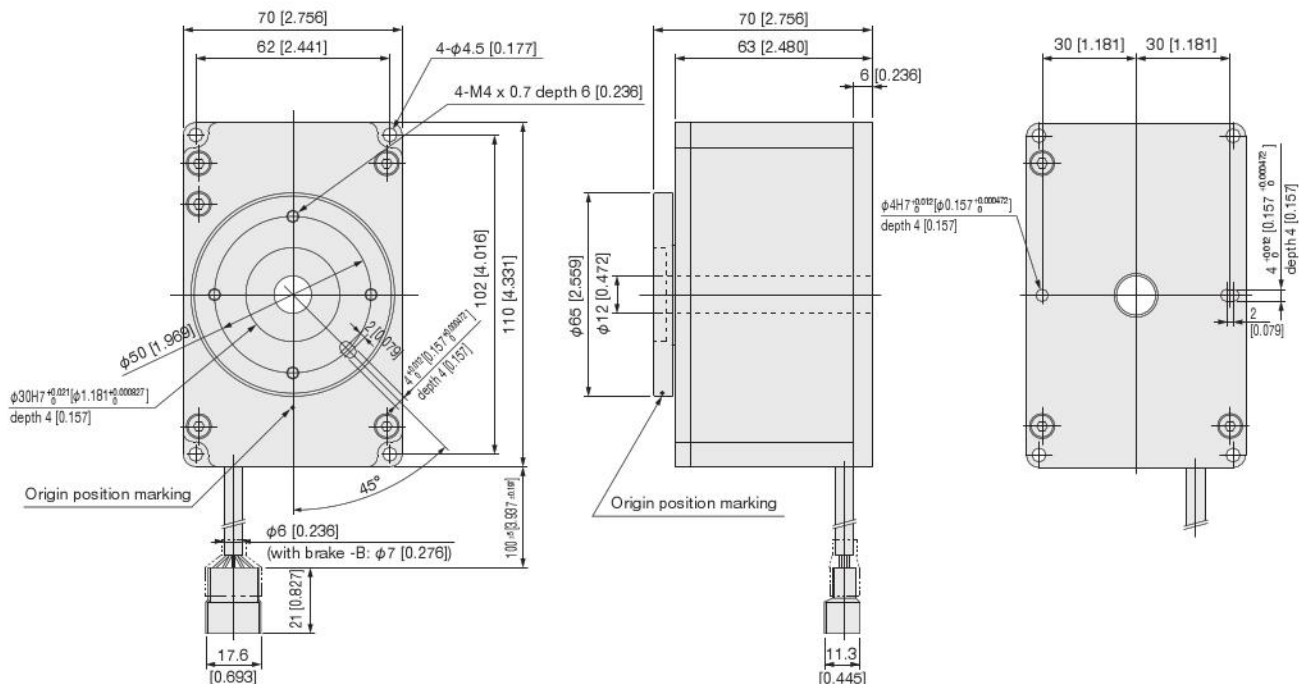

*The origin position of the table is when the slot of the locating dowel pin is in the position indicated in the figure above.

EWHRT40A

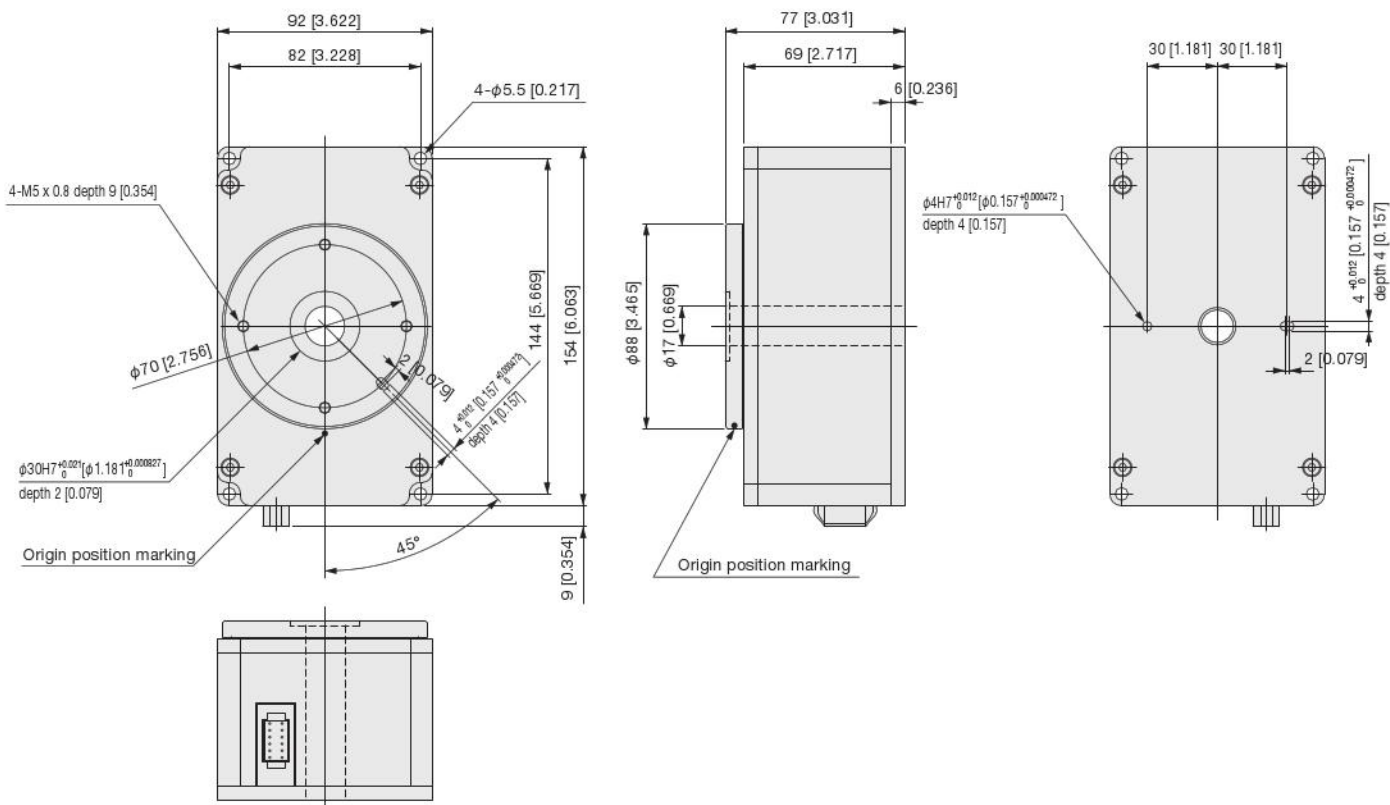

*The origin position of the table is when the slot of the locating dowel pin is in the position indicated in the figure above.

EWHRT60A

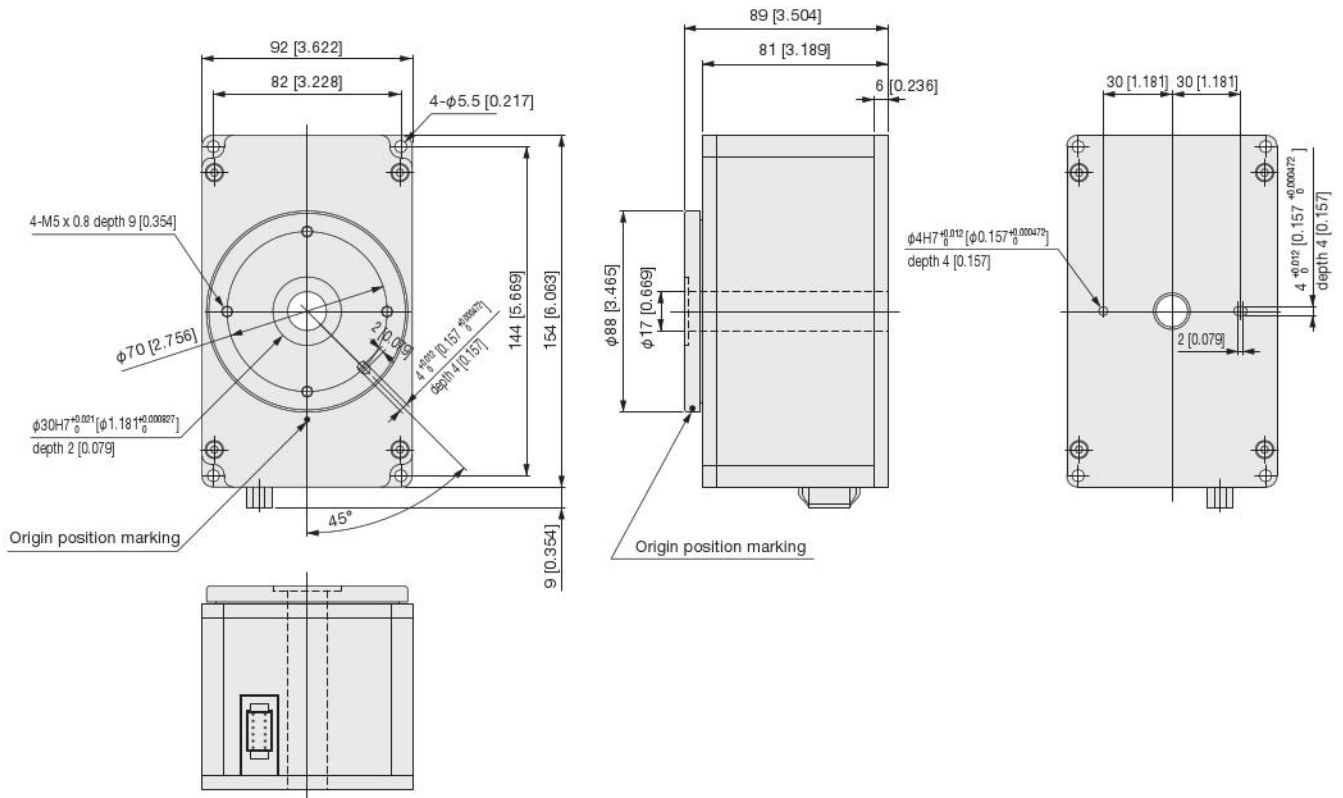

*The origin position of the table is when the slot of the locating dowel pin is in the position indicated in the figure above.

EW2H

EW2HL

EWHA A

EWHA H

EWHRT

EWM5

Material

Controller

Point input type



Specifications

Item	Type	EWHC-RA,EWHC-RS
Axis control	Motor drive system	Microstep drive
	Control method	Closed loop control ^{*1}
	Operating method	PTP
	Origin detection method	Encoder Z phase
	Position detection method	Encoder A/B phase output
	Minimum setting distance (angle)	0.01°
	Acceleration setting	1 to 100 % (automatically set by load inertia)
	Point setting	64 points
	Point input method	Numeric input, teaching input, direct teaching
External input/output	Point setting input	6 point (POS0~POS5) photocoupler receptor 5 mA TYP/point
	Control input	3 point (ORG, START, STOP) photocoupler receptor 5 mA TYP/point
	Control output	3 point (RDY, BUSY, INPOS) 30 mA Max./point
	Error detection output	Overload, wiring disconnection, data error, system error
	External communication	RS232C 1 ch (computer, TB communication)
	Motor drive output	Dedicated cable (with F.G.)
	Encoder input	Dedicated cable (shielded)
General specifications	Mass	0.2 kg [0.441 lb]
	Power supply	DC 24 V±10 % 1.6 A Max. (motor, I/O power supply shared) ^{*2}
	Operating temperature	0 to 40 °C [32 to 104°F]
	Operating humidity	35 to 85 % RH (without condensation)
	Storage temperature	-10 to 65 °C [14 to 149°F]
	Backup	Setting conditions retained in EEPROM
	Noise resistance	IEC61000-4-4 level 3
	Accessories	I/O cable, power cable

*1 Missed step detection is performed via a rotary encoder.

*2 The maximum consumption current value differs according to the actuator. See the table below.

Maximum consumption current (electric rotary actuator)

(A)

Model	EWHRT1A	EWHRT3A	EWHRT5A	EWHRT10A	EWHRT20A	EWHRT40A	EWHRT60A
Standard	0.6		1.0				1.3
With brake	-		1.0				1.6

Controller Wiring Method

1. When using the internal power supply of the controller (electric rotary actuator)

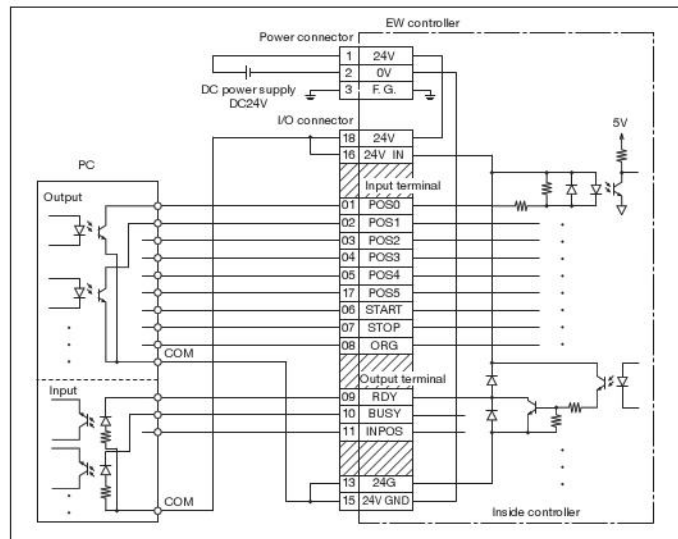

2. When not using the internal power supply of the controller (electric rotary actuator)

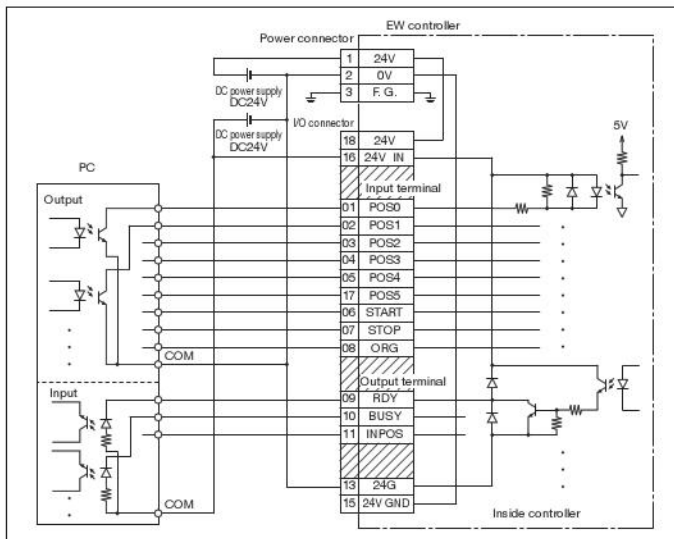

Controller

Pulse array input type



Specifications

Item	Type	EWHCP-RA, EWHCP-RS
Axis control	Motor drive system	Microstep drive
	Control method	Closed loop control ¹
	Operating method	Position control via pulse array input
	Origin detection method	Encoder Z phase
	Position detection method	Encoder A/B phase output
	Pulse array input method	Differential line driver/open collector
	Maximum input pulse frequency ²	Max. 200 kpps (differential line driver)/Max 60 kpps (open collector)
	Pulse array input instruction format	CW/CCW, pulse/code (positive/negative logic available)
External input/output	Control input	6 points (alarm reset, clear counter, brake release, servo ON, pulse input prohibited/origin return stopped, origin return) 5 mA TYP./point
	Control output	4 points (preparations complete, pulse input reception available, positioning complete, zone output) 30 mA Max./point
	Error detection output	Overload, data error, system error
	External communication	RS232C 1 ch (computer, TB communication)
	Motor drive output	Dedicated cable (with F.G.)
	Encoder input	Dedicated cable (shielded)
	Pulse array input	Dedicated cable (twisted pair cable)
General specifications	Mass	0.2 kg [0.441 lb]
	Power supply	DC 24 V±10 % 1.6A Max. (motor, I/O power supply shared) ³
	Operating temperature	0 to 40 °C [32 to 104°F]
	Operating humidity	35 to 85 % RH (without condensation)
	Storage temperature	-10 to 65 °C [14 to 149°F]
	Backup	Setting conditions retained in EEPROM
	Noise resistance	IEC61000-4-4 level 3
	Accessories	I/O cable, power cable, pulse array input cable ⁴ , conversion cable for pulse array input connector x 2 ⁵

¹ Missed step detection and force control when gripping are performed via a rotary encoder.

² The actual maximum input pulse count is regulated by the maximum speed of each actuator.

³ The maximum consumption current value differs according to the actuator. See the table below.

⁴ The length of the pulse array input cable is 1 m [3.281 ft.].

⁵ Note that the method for connecting the pulse array input cable differs for the differential line driver input and open collector input (see the instruction manual for details).

Maximum consumption current (electric rotary actuator)

(A)

Model	EWHRT1A	EWHRT3A	EWHRT5A	EWHRT10A	EWHRT20A	EWHRT40A	EWHRT60A
Standard	0.6		1.0			1.3	
With brake	—		1.0			1.6	

Controller Wiring Method

1. When using the internal power supply of the controller (electric rotary actuator)

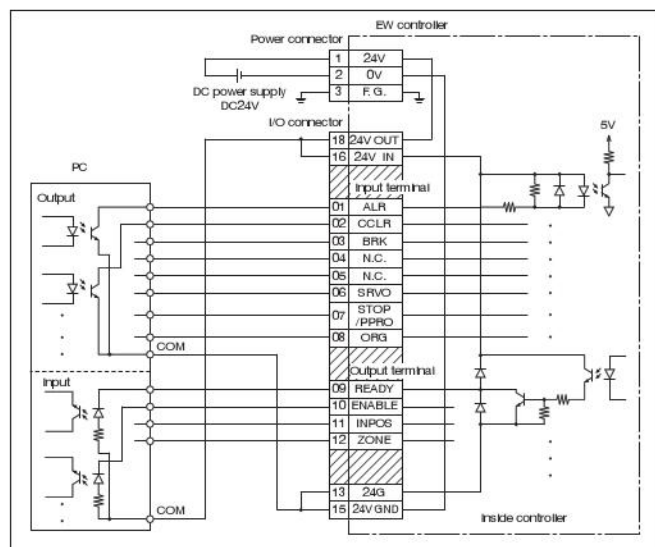

2. When not using the internal power supply of the controller (electric rotary actuator)

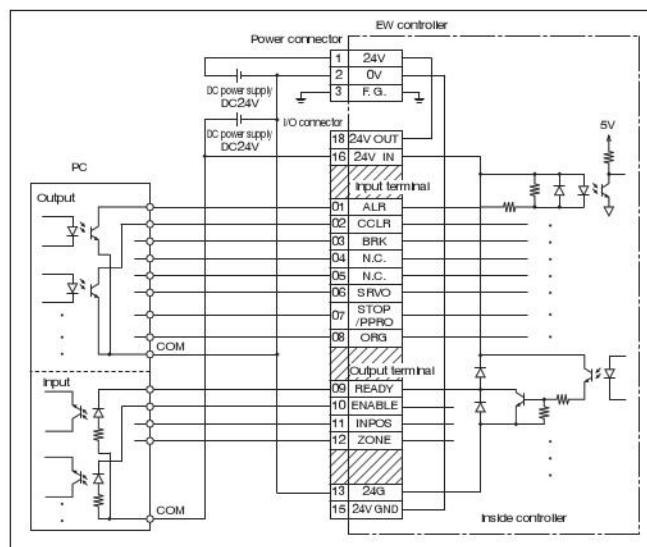

Controller dimensions mm [in.]

(point input type)

EWHC-  - 

DIN rail mounting plate

Not specified: Without

DP: With (cannot be selected without controller)

Applicable main units

RA : For EWHRT3A, 5A, 10A, 20A, 40A, 60A

RS : For EWHRT1A

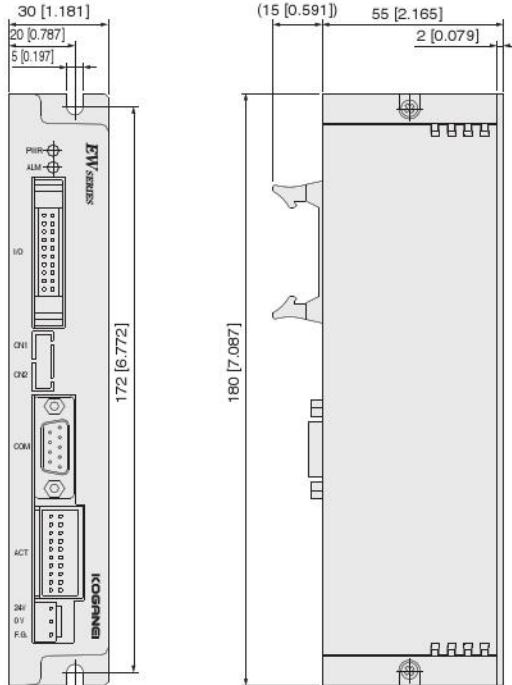

(pulse array input type)

EWHCP-  - 

DIN rail mounting plate

Not specified: Without

DP: With (cannot be selected without controller)

Applicable main units

RA : For EWHRT3A, 5A, 10A, 20A, 40A, 60A

RS : For EWHRT1A

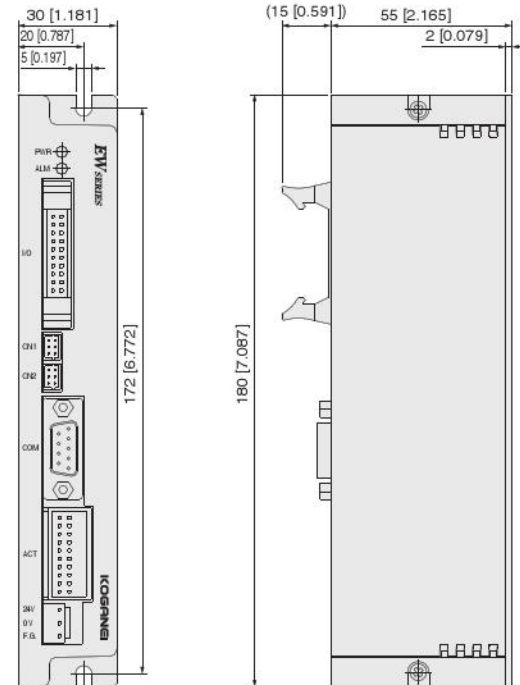

Controller dimensions mm [in.]

● DIN rail mounting plate

EW2DP

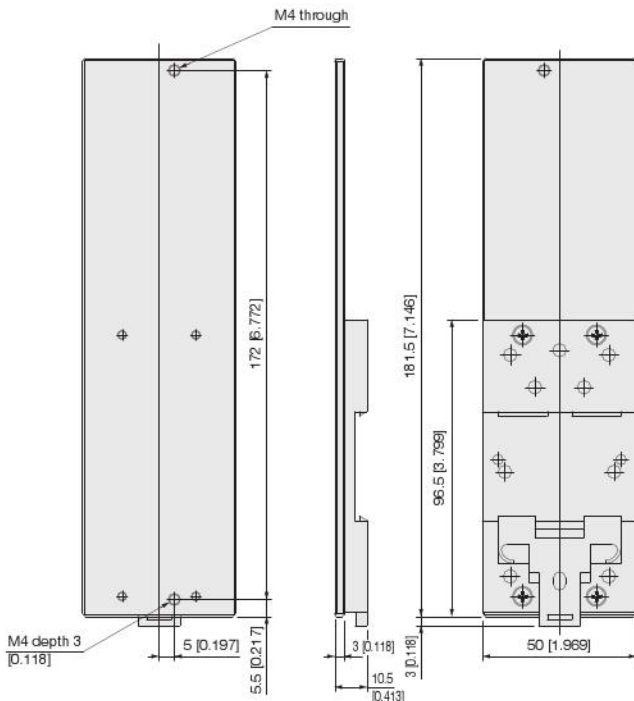
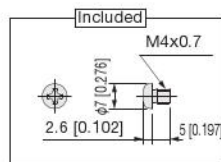

Controller wiring method (pulse array input type)

● Differential line driver input circuit

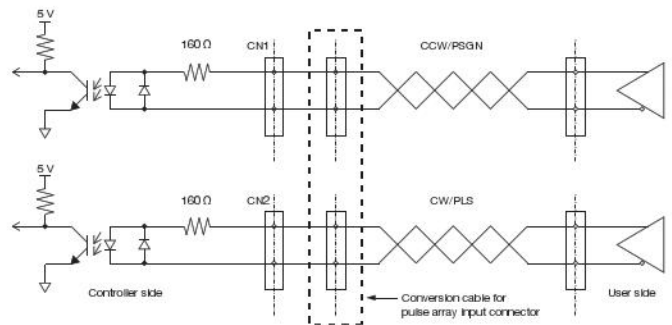

● Open collector input circuit

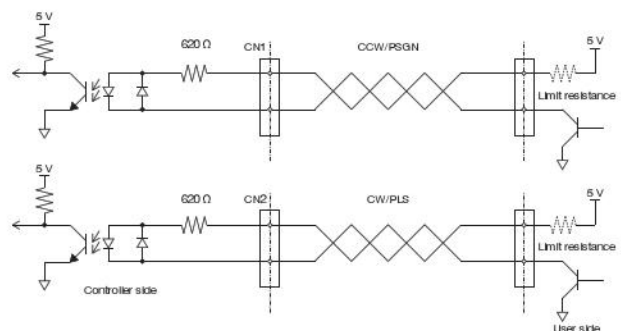

[Caution] When applying voltage of 5.5 V or higher, add current limit resistance (10 mA or less).

Controller dimensions mm [in.]

● Controller included

- I/O cable (type: product equivalent to EW2KI)

EW2KI

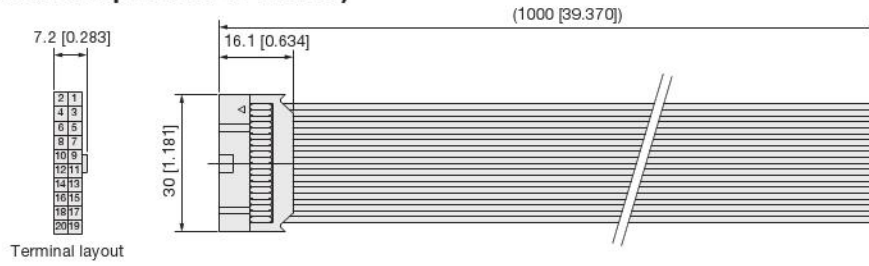

- Power cable (type: product equivalent to EW2KP)

EW2KP

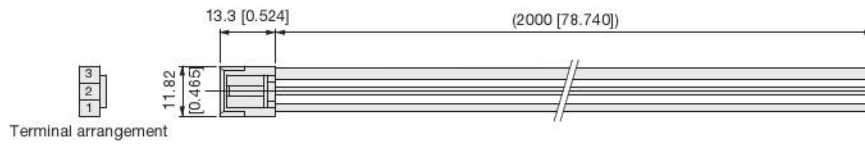

- Pulse array input cable (pulse array input type controller only)

EWHKY

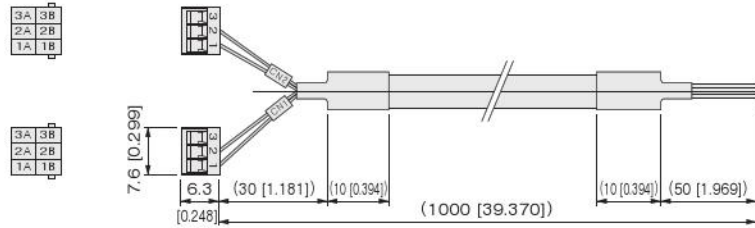

● Conversion cable for pulse array input connector (pulse array input type controller only)

*Make sure to use this conversion cable when the pulse array input signal is a differential line driver.

EWHKC

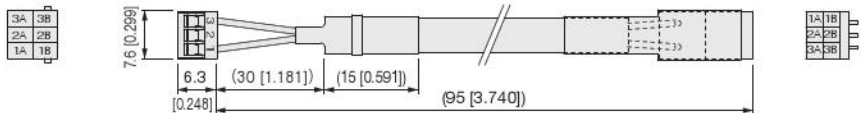

● Cable

- Relay cable (robot cable)

EWHKA-

3L: 3 m [9.843 ft.]
5L: 5 m [16.404 ft.]
3L:3000 [118.110]
5L:5000 [196.850]

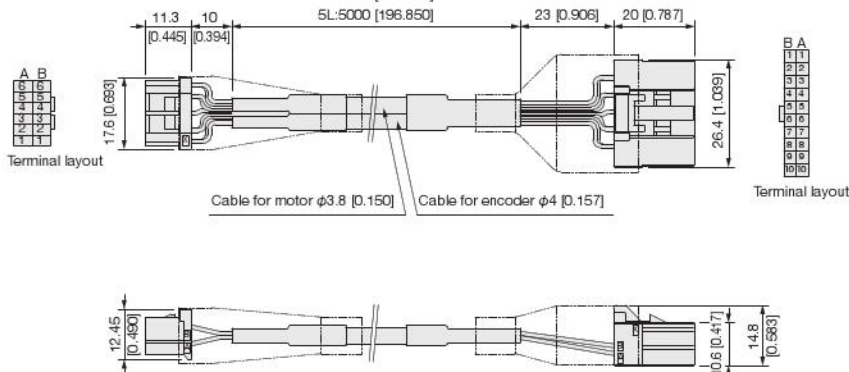

Main unit side connector

No.	Parts	Color
A1	F.G.	Brown
A2	A+	Red
A3	A-	Yellow
A4	B+	Green
A5	B-	White
A6	BRK	Black
B1	Shield	
B2	GND	Red
B3	5V	Yellow
B4	EA	Green
B5	EB	White
B6	EC	Black

Controller side connector

No.	Parts	Color
A1	A+	Red
B1	B+	Green
A2	A-	Yellow
B2	B-	White
A3	F.G.	Brown
B3	BRK	Black
A4	COM1	—
B4	COM2	—
A5		—
B5		—
A6	F.G.	—
B6	GND 5V	—
A7	DV+	Yellow
B7	DV-	Red
A8	EA+	—
B8	EA-	Green
A9	EB+	—
B9	EB-	White
A10	EC+	—
B10	EC-	Black

Selection guidelines

● Electric rotary actuator

● When securing a workpiece to the table of the electric rotary actuator using a bolt, etc., do so with the table or workpiece retained.

● Duty limitation

Use the electric rotary actuator at a duty of 50 % or less.

$$\text{Duty} = \frac{\text{Operation time}}{\text{Operation time} + \text{rest time}} \times 100 (\%)$$

● Load torque and speed limitation

When using the table installed in the vertical direction, design the workpiece so that load torque will not be applied where possible. When load torque is applied, ensure that it is at or below 60 % of the maximum torque of the actuator.



When load torque is applied, use the speed setting within the following limits.

Load ratio (%)	20	40	60
Speed setting (%)	50 or below	33 or below	25 or below

$$\text{Load ratio} = \frac{\text{Load torque}}{\text{Maximum torque}} \times 100 (\%)$$

● Example of calculating mass moment of inertia



The workpiece mass moment of inertia must be at or below the maximum load inertia.

1. When there is disk shaped load on the rotation axis

Load material: Aluminum alloy (density $2.7 \times 10^3 \text{ kg}\cdot\text{m}^{-3}$)

$$I = \frac{md^2}{8}$$

I : Mass moment of inertia about the rotation axis ($\text{kg}\cdot\text{m}^2$)

d : Disk outer diameter (m)

m : Mass (kg)

d = 0.16 (m)

$$m = \frac{\pi \times 0.16^2}{4} \times 0.017 \times 2.7 \times 10^3$$

$$= 0.92 \text{ (kg)}$$

$$I = \frac{0.92 \times 0.16^2}{8}$$

$$= 3.0 \times 10^{-3} \text{ (kg}\cdot\text{m}^2) [2.213 \times 10^{-3} \text{ (bf}\cdot\text{ft}\cdot\text{sec}^2)]$$

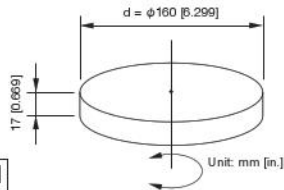

The maximum load inertia of the EWHRT5A.

2. For cuboid load offset from the rotation axis

Load material: Aluminum alloy (density $2.7 \times 10^3 \text{ kg}\cdot\text{m}^{-3}$)

$$I = \frac{m}{12} (a^2 + b^2) + mL^2$$

I : Mass moment of inertia about the rotation axis ($\text{kg}\cdot\text{m}^2$)

a, b : Side length (m)

L : Offset from rotation axis and load center (m)

m : Mass (kg)

$$m = 0.22 \times 0.1 \times 0.03 \times 2.7 \times 10^3$$

$$= 1.78 \text{ (kg)}$$

$$I = \frac{m}{12} (a^2 + b^2) + mL^2$$

$$= \frac{1.78}{12} (0.22^2 + 0.1^2) + (1.78 \times 0.08^2)$$

$$= 2.0 \times 10^{-2} \text{ (kg}\cdot\text{m}^2) [1.475 \times 10^{-2} \text{ (bf}\cdot\text{ft}\cdot\text{sec}^2)]$$

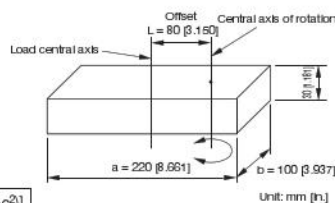

The maximum load inertia of the EWHRT20A.

● Operation time (operation angle 90°)

EWHRT1A

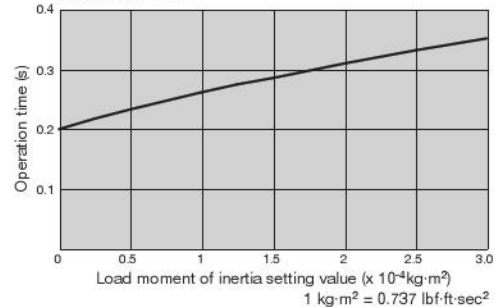

EWHRT3A, EWHRT5A, EWHRT10A

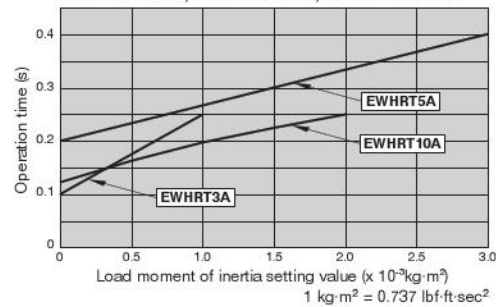

EWHRT20A

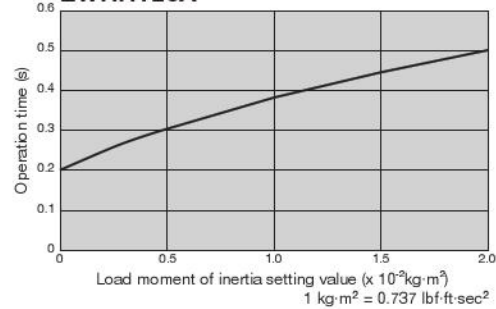

EWHRT40A

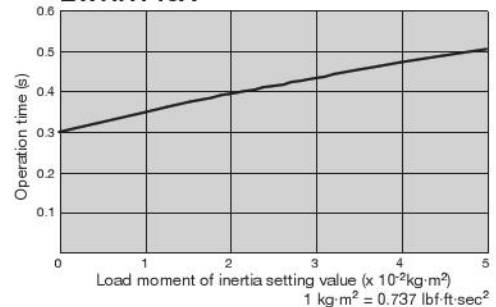

EWHRT60A

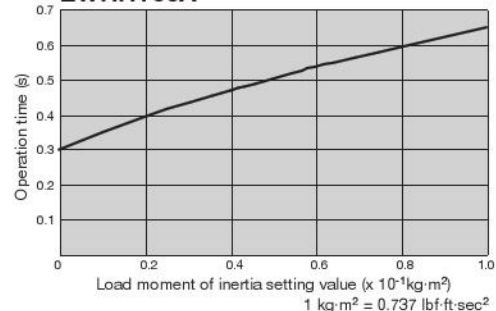

Remarks: At maximum speed and maximum acceleration (when there is no load torque)

Selection guidelines

● Electric rotary actuator

● Mass moment of inertia calculation diagrams

[When the rotation axis passes the workpiece]

Disk

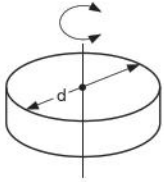

- Diameter d (m)
- Mass m (kg)

■ Mass moment of inertia I (kg·m²)

$$I = \frac{md^2}{8}$$

Stepped disk

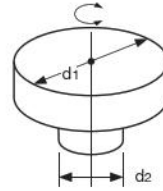

- Diameter d₁ (m)
- Diameter d₂ (m)
- Mass d₁ part m₁ (kg)
- Mass d₂ part m₂ (kg)

■ Mass moment of inertia I (kg·m²)

$$I = \frac{1}{8} (m_1 d_1^2 + m_2 d_2^2)$$

Bar (center of rotation at edge)

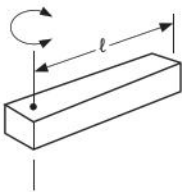

- Bar length l (m)
- Mass m (kg)

■ Mass moment of inertia I (kg·m²)

$$I = \frac{ml^2}{3}$$

Bar (center of rotation at center of gravity)

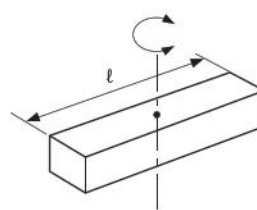

- Bar length l (m)
- Mass m (kg)

■ Mass moment of inertia I (kg·m²)

$$I = \frac{ml^2}{12}$$

Rectangular parallelepiped

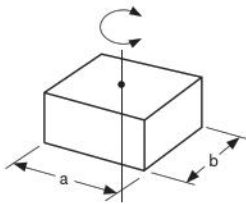

- Side length a (m)
- Side length b (m)
- Mass m (kg)

■ Mass moment of inertia I (kg·m²)

$$I = \frac{m}{12} (a^2 + b^2)$$

[When the rotation axis is offset from the workpiece]

Rectangular parallelepiped

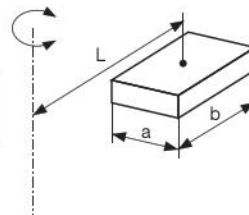

- Side length a (m)
- Side length b (m)
- Distance from the rotation axis to the load center L (m)
- Mass m (kg)

■ Mass moment of inertia I (kg·m²)

$$I = \frac{m}{12} (a^2 + b^2) + mL^2$$

● System configuration (example)

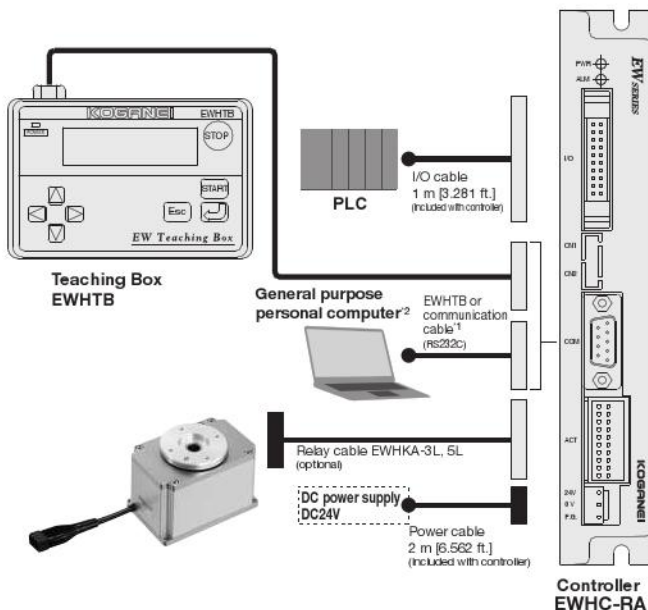

*1 RS232C cable (for reference)

Specifications: D-sub 9 pin (female) ↔ D-sub 9 pin (female)/cross cable
Type: C232R-ECO915 (1.5 m [4.921 ft.])/C232R-ECO930 (3.0 m [9.842 ft.])
Manufacturer: Elecom Co., Ltd.

The communication cable must be provided by the customer.

*2 The support software for setting the controller can be downloaded from the KOGANEI website free of charge.

NS slider



Specifications

● Main unit basic specifications

Item	Type	EWM5HSA/EWM5HLA	EWM5SSA/EWM5SLA
Motor		Two phase stepping motor	
Maximum thrust ¹	N	18 to 27	42 to 65
Maximum payload ²	kg [lb]	1 [2.205] (horizontal), 0.4 [0.882] (vertical)	2 [4.409] (horizontal), 0.8 [1.764] (vertical)
Maximum speed ³	mm/s [in./sec]	120 [4.724]	50 [1.969]
Minimum operation time	s	0.25 (st.20), 0.42 (st.40)	0.50 (st.20), 0.90 (st.40)
Minimum speed	mm/s [in./sec]	1 [0.039]	
Repeated positioning precision	mm [in.]	±0.03 [0.001]	
Operating temperature range		0 to 40 [32 to 104]	
Allowable moment	My (yawing)	N·m [in·lbf]	1 [8.9]
	Mp (pitching)	N·m [in·lbf]	1 [8.9]
	Mr (rolling)	N·m [in·lbf]	1.5 [13.3]
Mass	kg [lb]	0.27 [0.595] (st.20, short table type), 0.30 [0.661] (st.20, long table type)	
		0.35 [0.772] (st.40, short table type), 0.40 [0.882] (st.40, long table type)	
Applicable controllers		EWHC-NH, EWHCP-NH	

¹ For details on cylinder thrust, see the graph on page 58.

² There is no retention function when the power is OFF.

³ The maximum speed when pushing is 10 mm/s [0.394 in./sec].

● See pages 54 and 55 for the controller specifications.

Allowable moment

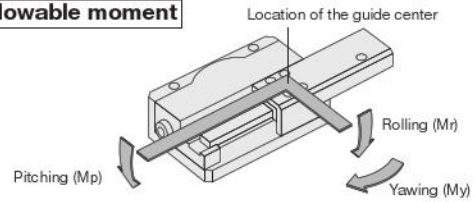

Order Codes

EWM5

Elewave NS slider

Type

H: High-speed type
S: High thrust type

Table size

S: Short table
L: Long table

Stroke

20: 20 mm [0.787 in.]
40: 40 mm [1.575 in.]

Controller type

Not specified: Without controller

C: With EWHC-NH (point input type)
CP: With EWHCP-NH (pulse array input type)

Cable length (relay cable)

Not specified: Without cable
3L: 3 m [9.843 ft.]
5L: 5 m [16.404 ft.]

DIN rail mounting plate

Not specified: Without mounting plate

DP: With mounting plate (cannot be selected without controller)

● Additional parts

Point input type controller

[Accessories]
· Power cable
· I/O cable

EWHC - NH -



DIN rail mounting plate

Not specified: Without mounting plate
DP: With mounting plate

Cable (relay cable)¹
¹ Robot cable

EWHKA -



Cable length
3L: 3 m [9.843 ft.]
5L: 5 m [16.404 ft.]

Pulse array input type controller

[Accessories]
· Power cable
· I/O cable
· Pulse array input cable
· Conversion cable for pulse array input connector

EWHCP - NH -



DIN rail mounting plate

Not specified: Without mounting plate
DP: With mounting plate

Teaching² box

EWHTB



² See page 59 for the specifications and dimensions.

DIN rail mounting plate

EW2DP



NS slider dimensions mm [in.]

EWM5HSA-20

EWM5SSA-20

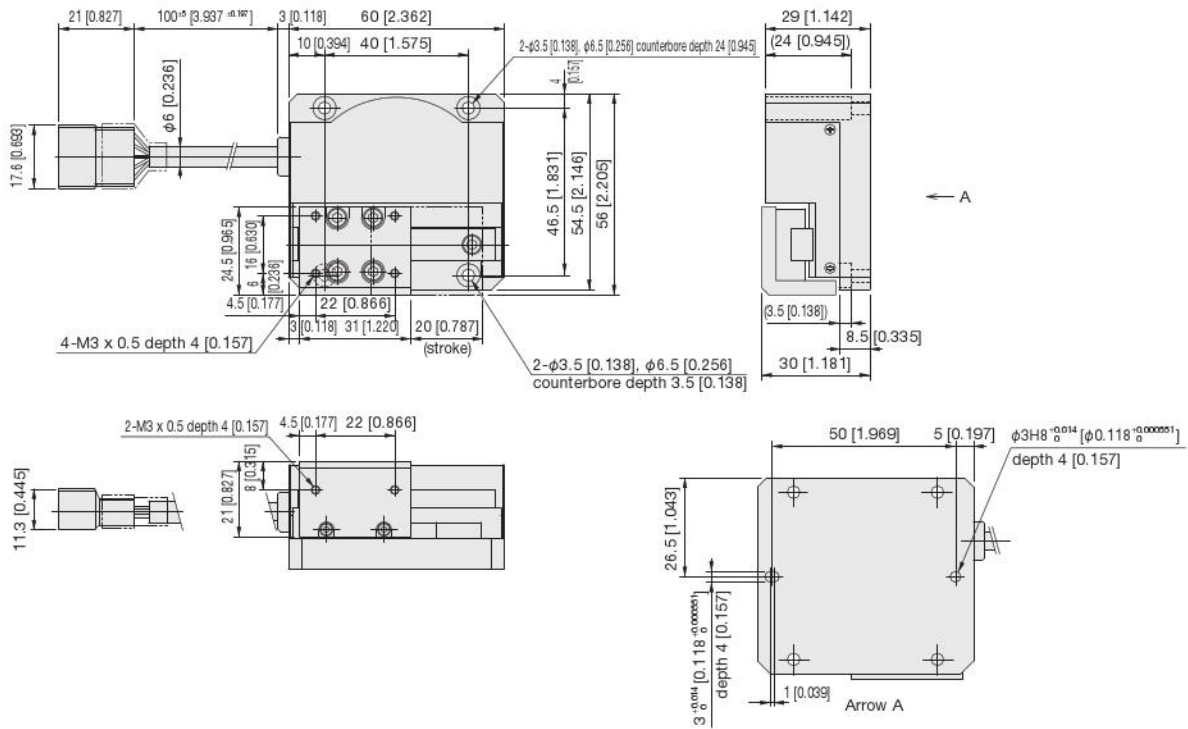

EWM5HSA-40

EWM5SSA-40

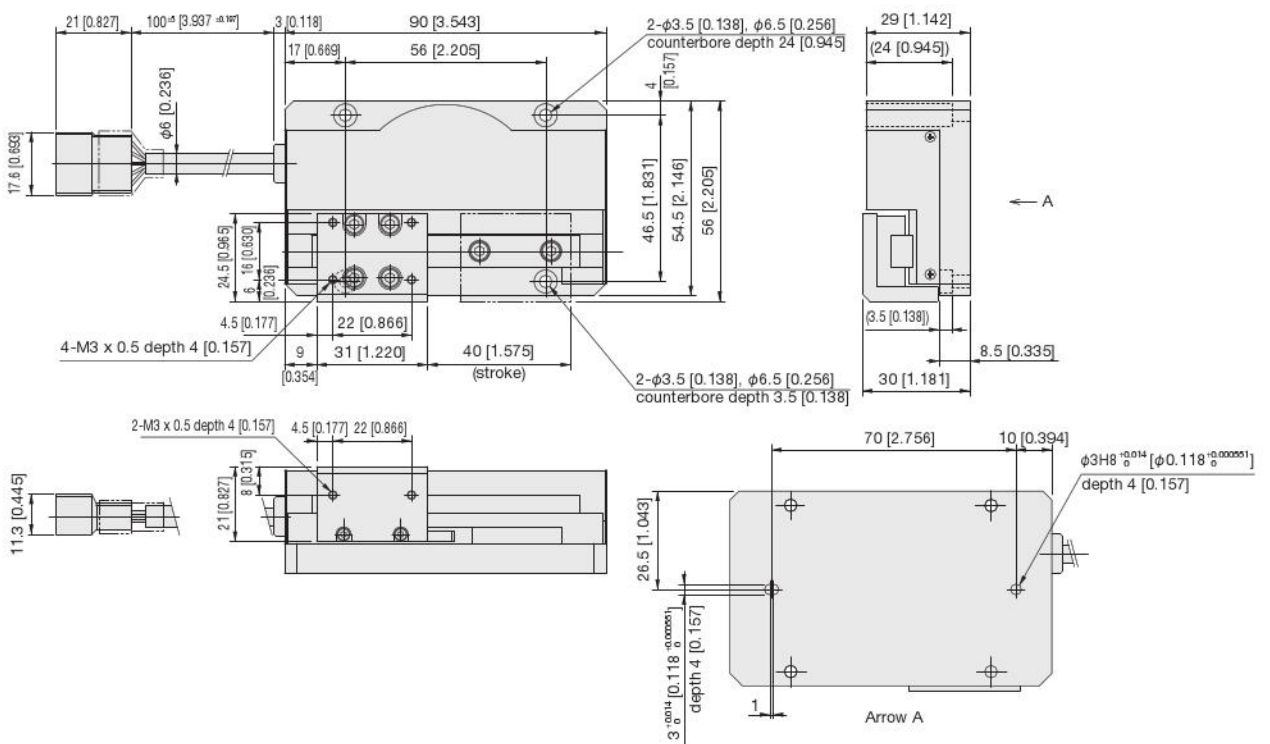

EW2H

EW2HL

EWHA □ A

EWHA □ H

EWHRT

EWMS

Material

EWM5HLA-20
EWM5SLA-20

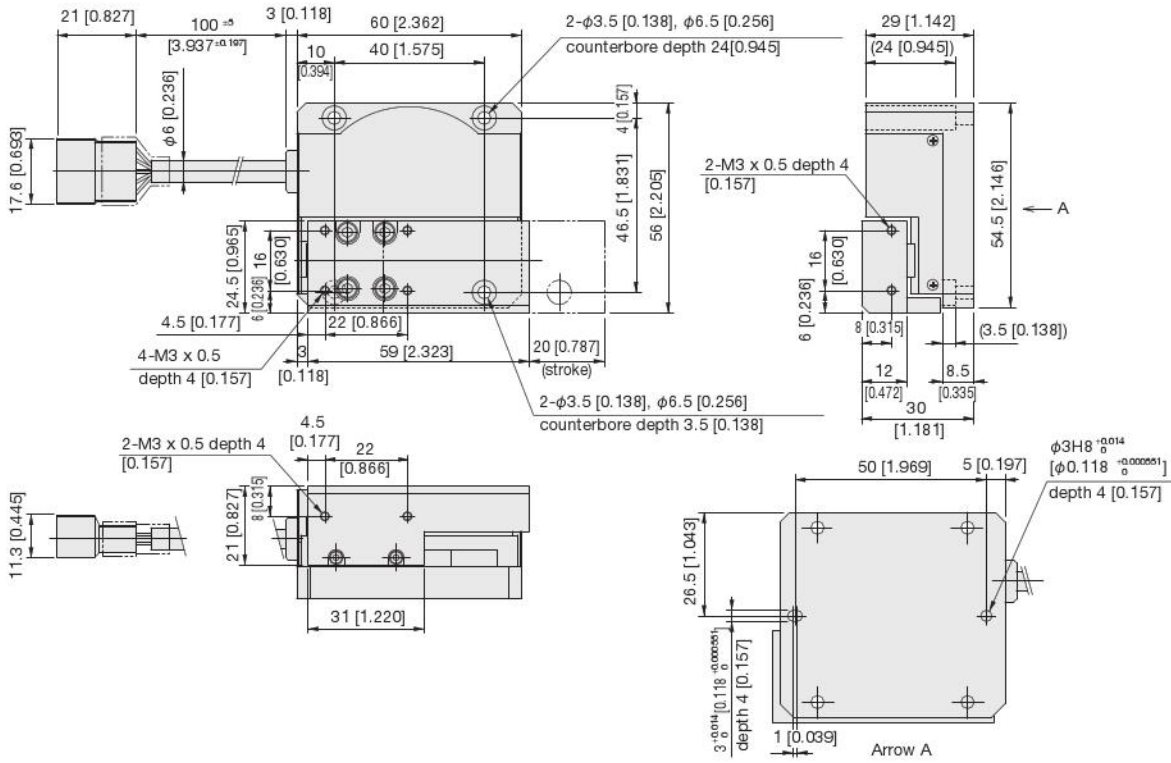

EWM5HLA-40
EWM5SLA-40

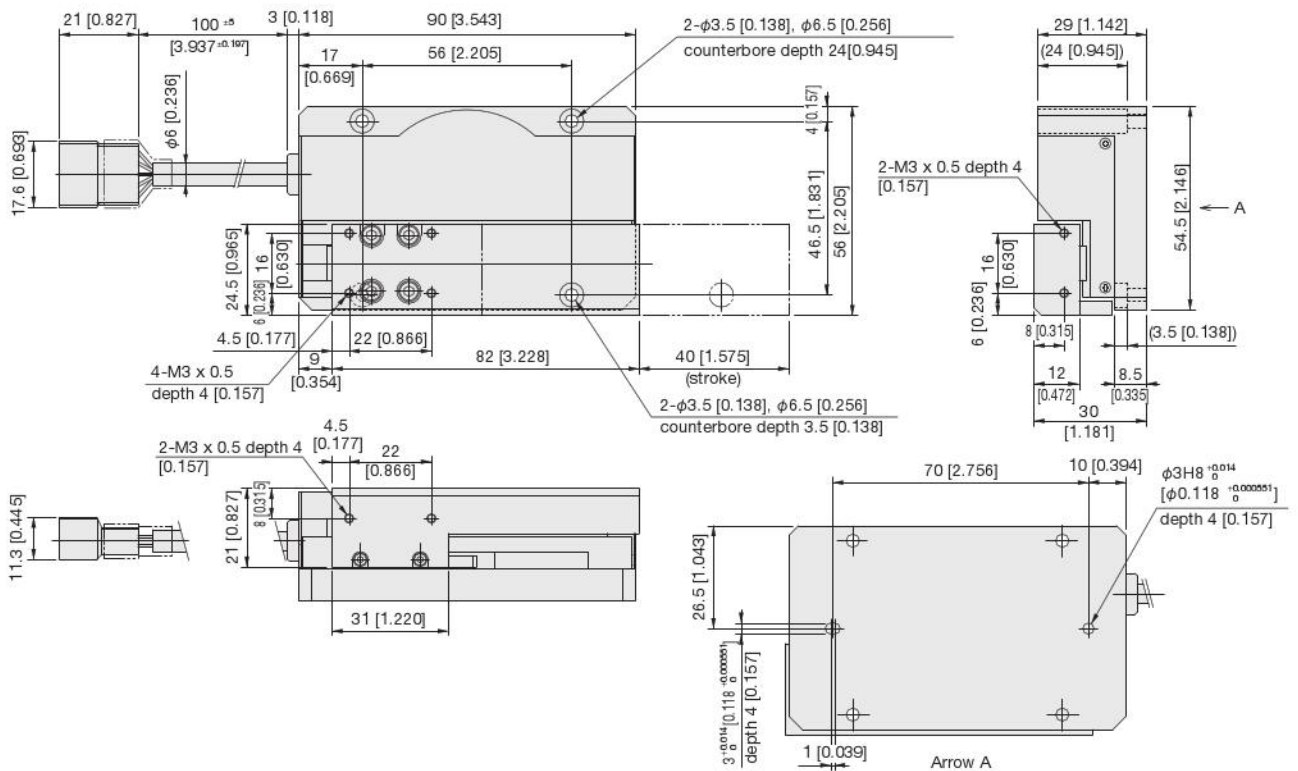

Controller

Point input type



Specifications

Item	Type	EWHC-NH
Axis control	Motor drive system	Microstep drive
	Control method	Closed loop control ¹
	Operating method	PTP, force control
	Origin detection method	Stroke end detection
	Position detection method	Encoder A/B phase output
	Minimum setting distance (angle)	0.01 mm [0.000394 in.]
	Acceleration setting	1 to 100 %
	Point setting	64 points
	Point input method	Numeric input, teaching input, direct teaching
External input/output	Point setting input	6 point (POS0~POS5) photocoupler receptor 5 mA TYP/point
	Control input	3 point (ORG, START, STOP) photocoupler receptor 5 mA TYP/point
	Control output	4 point (READY, BUSY, HOLD, INPOS) 30 mA Max./point
	Error detection output	Overload, wiring disconnection, data error, system error
	External communication	RS232C 1 ch (computer, TB communication)
	Motor drive output	Dedicated cable (with F.G.)
	Encoder input	Dedicated cable (shielded)
General specifications	Mass	0.2 kg [0.441 lb]
	Power supply	DC 24 V±10 % 1.0 A Max. (motor, I/O power supply shared) ²
	Operating temperature	0 to 40 °C [32 to 104°F]
	Operating humidity	35 to 85 % RH (without condensation)
	Storage temperature	-10 to 65 °C [14 to 149 °F]
	Backup	Setting conditions retained in EEPROM
	Noise resistance	IEC61000-4-4 level 3
	Accessories	I/O cable, power cable

¹ Missed step detection and force control when gripping are performed via a rotary encoder.

² The maximum consumption current value differs according to the actuator. See the table below.

Maximum consumption current (NS slider, electric hand)

(A)

Model	EW5□	EWHA12A	EWHA24A	EWHA36A	EWHA6H	EWHA12H	EWHA24H	EWHA36H
Maximum consumption current			0.6				1.0	

Controller Wiring Method

1. When using the internal power supply of the controller (NS slider)

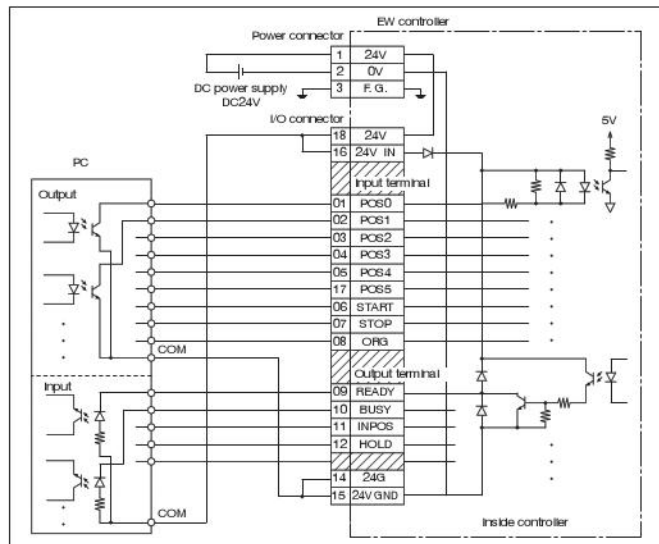

2. When not using the internal power supply of the controller (NS slider)

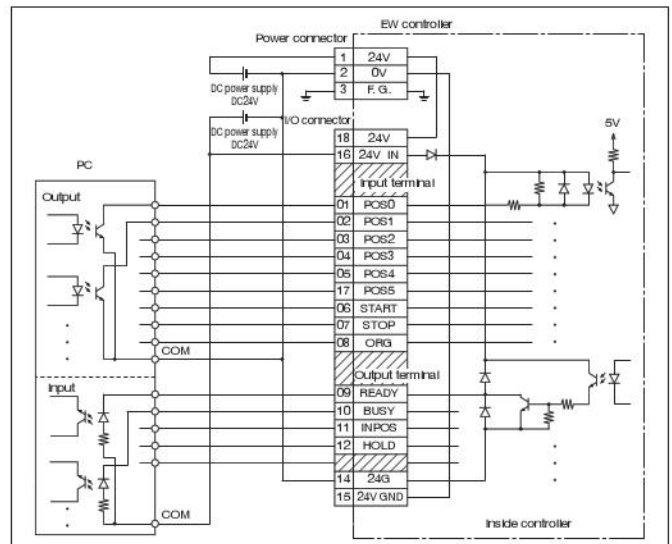

Controller

Pulse array input type



Specifications

Item	Type	EWHCP-NH
Axis control	Motor drive system	Microstep drive
	Control method	Closed loop control ¹
	Operating method	Position control and force control via pulse array input
	Origin detection method	Stroke end detection
	Position detection method	Encoder A/B phase output
	Pulse array input method	Differential line driver/open collector
	Maximum input pulse frequency ²	Max. 200 kpps (differential line driver)/Max. 60 kpps (open collector)
	Pulse array input instruction format	CW/CCW, pulse/code (positive/negative logic available)
External input/output	Control input	6 points (alarm reset, clear counter, pushing mode transfer, servo ON, pulse input prohibited/origin return stopped, origin return) 5 mA TYP/point
	Control output	4 points (preparations complete, pulse input reception available, positioning complete/pushing operation complete, zone output) 30 mA Max./point
	Error detection output	Overload, data error, system error
	External communication	RS232C 1 ch (computer, TB communication)
	Motor drive output	Dedicated cable (with F.G.)
	Encoder input	Dedicated cable (shielded)
	Pulse array input	Dedicated cable (twisted pair cable)
General specifications	Mass	0.2 kg [0.441 lb]
	Power supply	DC 24 V±10 % 1.0 A Max. (motor, I/O power supply shared) ³
	Operating temperature	0 to 40 °C [32 to 104°F]
	Operating humidity	35 to 85 % RH (without condensation)
	Storage temperature	-10 to 65 °C [14 to 149°F]
	Backup	Setting conditions retained in EEPROM
	Noise resistance	IEC61000-4-4 level 3
	Accessories	I/O cable, power cable, pulse array input cable ⁴ , conversion cable for pulse array input connector x 2 ⁵

¹ Missed step detection and force control when gripping are performed via a rotary encoder.

² The actual maximum input pulse count is regulated by the maximum speed of each actuator.

³ The maximum consumption current value differs according to the actuator. See the table below.

⁴ The length of the pulse array input cable is 1 m [3.281 ft.].

⁵ Note that the method for connecting the pulse array input cable differs for the differential line driver input and open collector input (see the instruction manual for details).

Maximum consumption current (NS slider, electric hand)

(A)

Model	EWM5 □	EWHA12A	EWHA24A	EWHA36A	EWHA6H	EWHA12H	EWHA24H	EWHA36H
Maximum consumption current	0.6	0.6					1.0	

Controller Wiring Method

1. When using the internal power supply of the controller (NS slider) 2. When not using the internal power supply of the controller (NS slider)

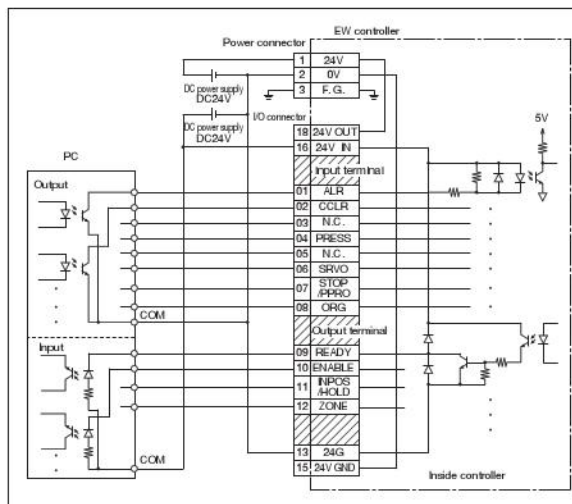
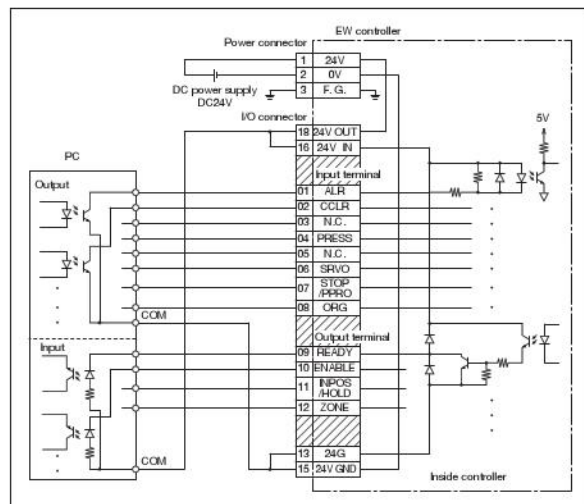

Controller dimensions mm [in.]

(point input type)

EWHC-NH-



DIN rail mounting plate

Not specified: Without

DP: With (cannot be selected without controller)

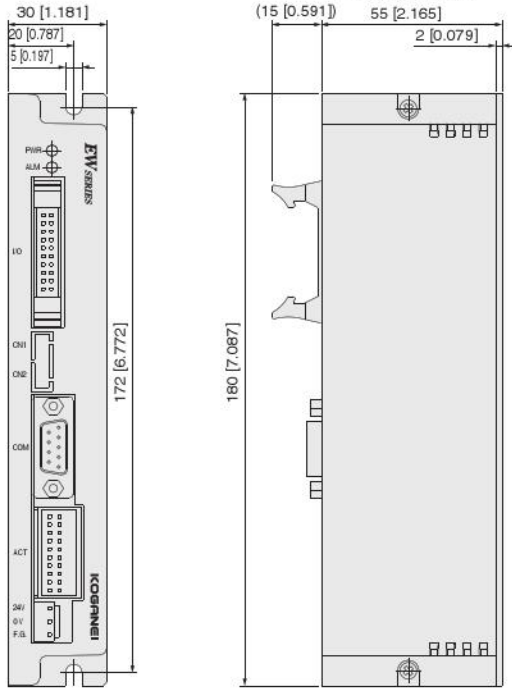

(pulse array input type)

EWHCP-NH-



DIN rail mounting plate

Not specified: Without

DP: With (cannot be selected without controller)

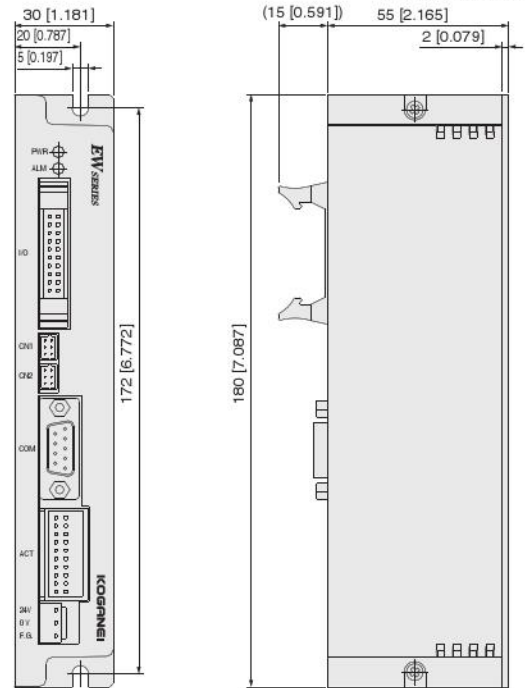

Controller dimensions mm [in.]

● DIN rail mounting plate

EW2DP

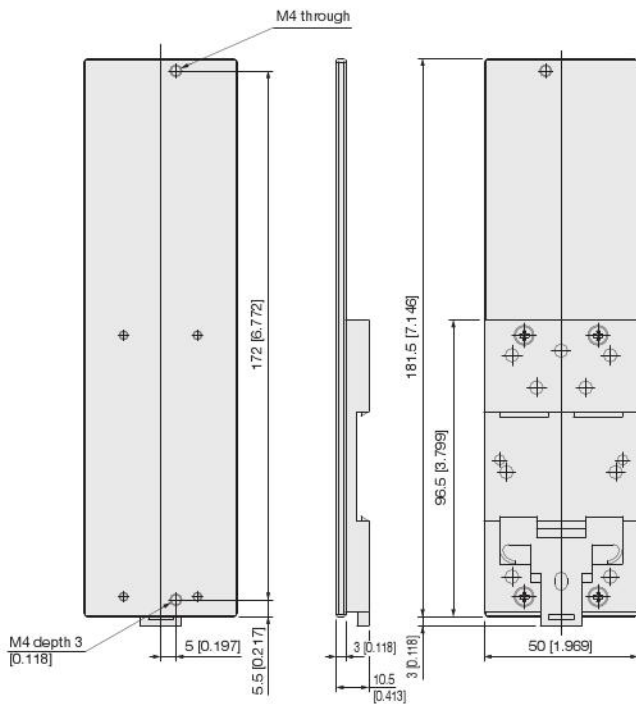
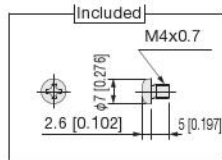

Controller wiring method (pulse array input type)

● Differential line driver input circuit

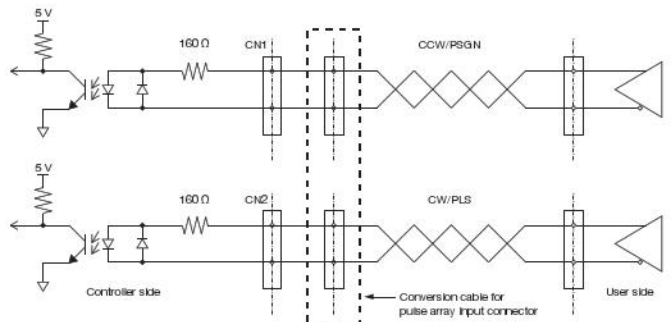

● Open collector input circuit

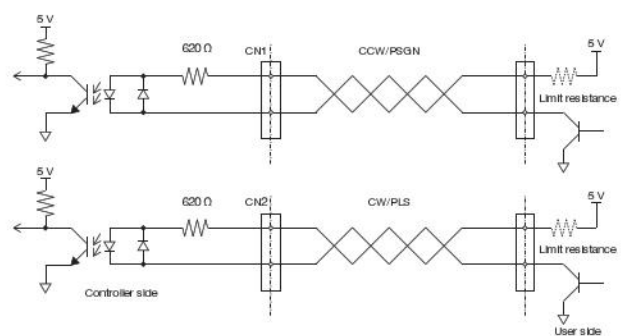

[Caution] When applying voltage of 5.5 V or higher, add current limit resistance (10 mA or less).

● Controller included

● I/O cable

EW2KI

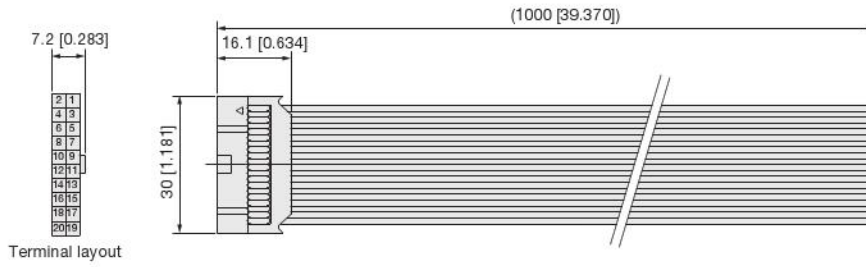

● Power cable

EW2KP

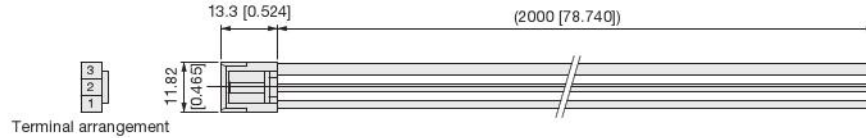

● Pulse array input cable (pulse array input type controller only)

EWHKY

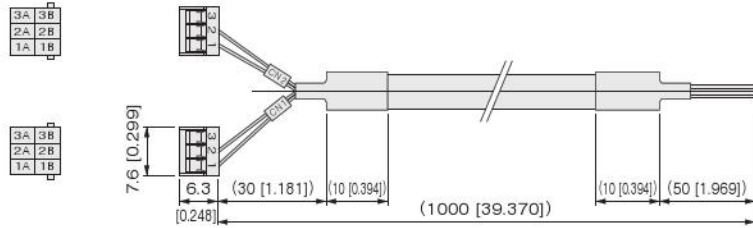

● Conversion cable for pulse array input connector (pulse array input type controller only)

*Make sure to use this conversion cable when the pulse array input signal is a differential line driver.

EWHKC

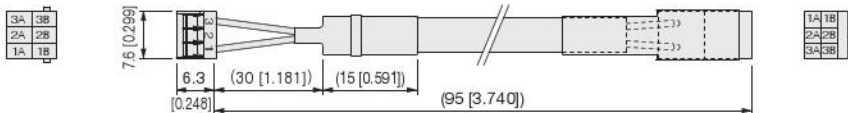

● Cable

● Relay cable (robot cable)

EWHKA-

3L: 3 m [9.843 ft.]
5L: 5 m [16.404 ft.]
3L:3000 [118.110]
5L:5000 [196.850]

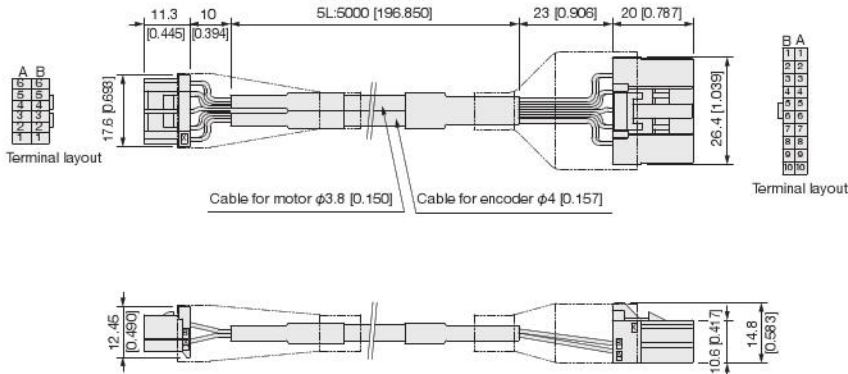

Main unit side connector

No.	Parts	Color
A1	F.G.	Brown
A2	A+	Red
A3	A-	Yellow
A4	B+	Green
A5	B-	White
A6	BRK	Black
B1	Shield	
B2	GND	Red
B3	5V	Yellow
B4	EA	Green
B5	EB	White
B6	EC	Black

Controller side connector

No.	Parts	Color
A1	A+	Red
B1	B+	Green
A2	A-	Yellow
B2	B-	White
A3	F.G.	Brown
B3	BRK	Black
A4	COM1	—
B4	COM2	—
A5		—
B5		—
A6	F.G.	—
B6	GND 5V	—
A7	DV+	Yellow
B7	DV-	Red
A8	EA+	—
B8	EA-	Green
A9	EB+	—
B9	EB-	White
A10	EC+	—
B10	EC-	Black

Selection guidelines

● NS slider

● Cylinder thrust

*The cylinder thrust range below is an estimate.

EWM5H□A

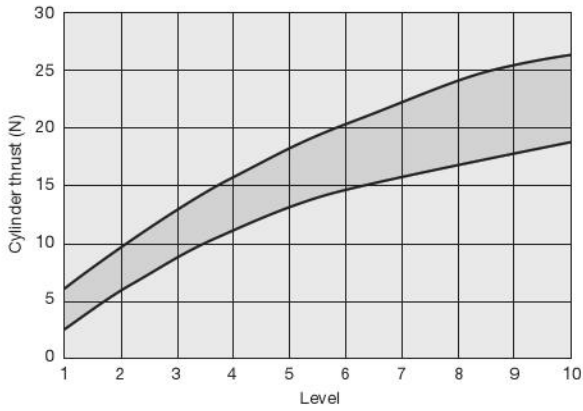

EWM5S□A

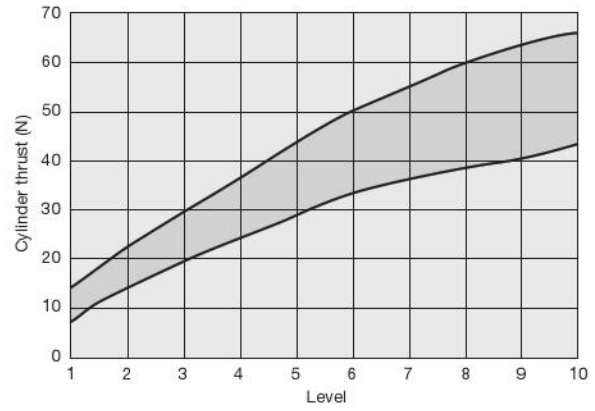

● NS slider operation mode (for the point input type controller)

Mode	Positioning		Pushing*		Pushing with acceleration/deceleration movement Perform acceleration/deceleration movement and add pushing operation.
	Acceleration or deceleration is performed and movement is stopped at the specified point.		Perform operation at a constant speed and pushing at the set force.		
Setting value	A	I	C	O	U
Description	Move to the position of the specified point with the coordinates of 0 as the origin position	Move to the position of the specified point from the current position	Operate to + side	Operate to - side	Move to the specified point and perform pushing operation at the speed of PRM7 from the distance before the point specified at PRM8
Operation pattern					
Remarks	—		—		Suitable for high-frequency soft pushing.

*1 Do not use C to O, or O to C motion in gripping mode as it will result in malfunction.

*2 Perform workpiece pushing in the pushing mode (C, O) or pushing mode (U) with acceleration/deceleration movement. When a workpiece is pushed with the positioning mode (A, I), an alarm is output and pushing cannot be performed normally.

● System configuration (example)

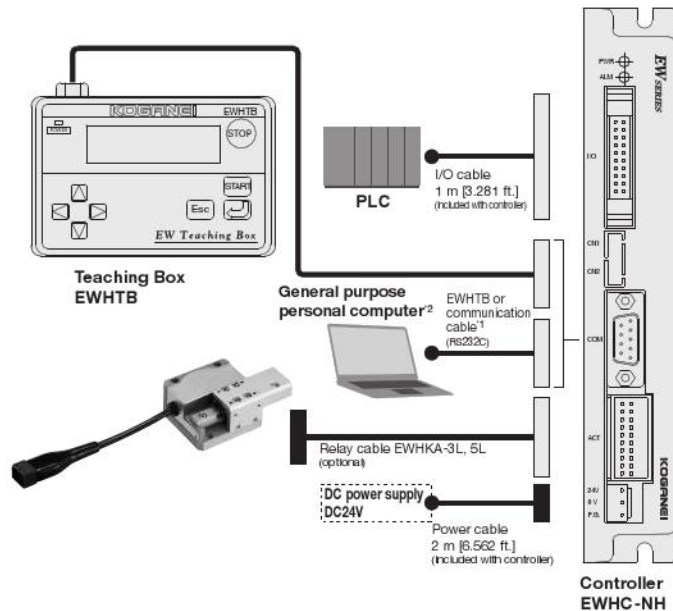

*1 RS232C cable (for reference)

Specifications: D-sub 9 pin (female) ↔ D-sub 9 pin (female)/cross cable
Type: C232R-ECO915 (1.5 m [4.921 ft.])/C232R-ECO930 (3.0 m [9.843 ft.])
Manufacturer: Elecom Co., Ltd.

The communication cable must be provided by the customer.

*2 The support software for setting the controller can be downloaded from the KOGANEI website free of charge.

Teaching Box

EWHTB



Specifications

Item	Type	EWHTB
Power supply	Power supply voltage	DC 12 V (supplied from controller)
	Consumption current	50 mA Max.
Indication	Setting display	LCD 16 characters x 2 lines
	Power supply indication	LED lit when power turned ON (internal 5 V)
General	Setting method	Key operation: 8 buttons
	Communication method	RS232C (serial communication)
	Cable length	3 m [9.843 ft.]
	Mass	Main unit: 200 g [7.055 oz.]
	Operating temperature	0 to 40 °C [32 to 104°F]
	Operating humidity	35 to 80 % RH (without condensation)
	Storage temperature	-10 to 65 °C [14 to 149°F]

Teaching box dimensions mm [in.]

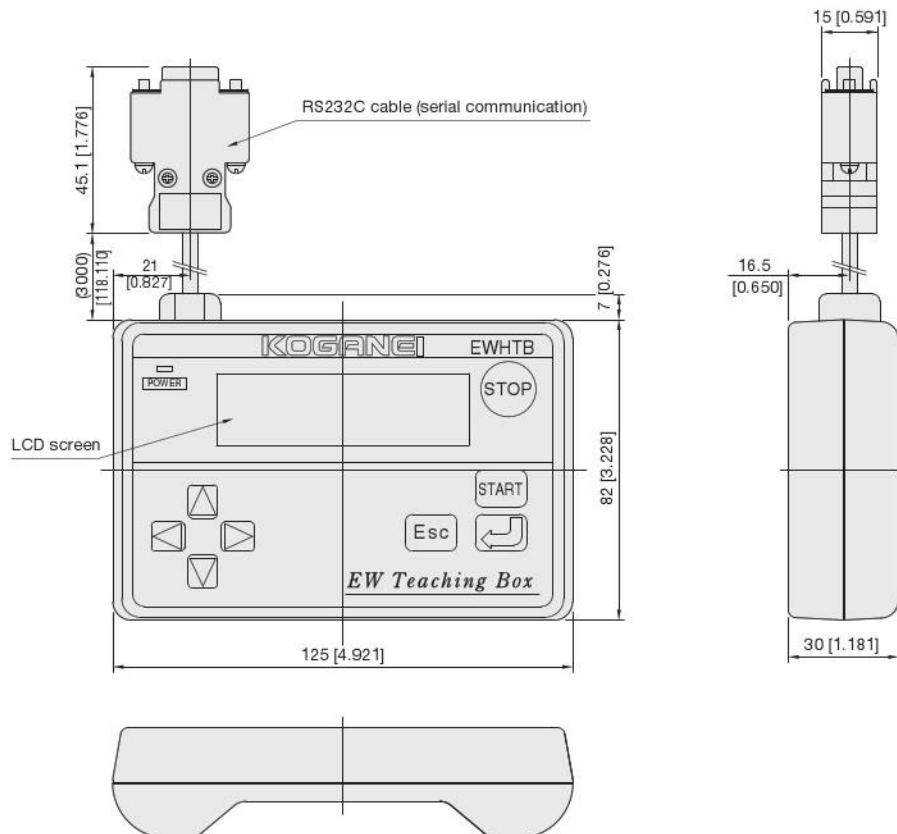

Material

INDEX

Supplementary materials

Frequently Asked Questions	61
Elewave Series Glossary	64
Operating Method	67
1. Size Detection Function (Electric Hand)	67
2. Workpiece Size Measurement Function (Electric Hand)	67
3. Workpiece Gripping Check Function (Electric Hand)	68
4. Zone Output Function (NS Slider)	68
Electric Actuator and Controller Correspondence Chart	69
Electric Hand Flat Type and Auto Hand Changer Combination Chart	69
Elewave Series Compatibility Chart	70

Information

Special Specification Products	72
Selected Software	72
Discontinued Models and Recommended Substitute Models	73

EW2H

EW2HL

EWHA □ A

EWHA □ H

EWHRT

EWM5

Material

Supplementary materials

Frequently Asked Questions

Item	Question	Answer	
Common to Elewave Series	Can program operation be performed with the support software?	No. Host equipment is required to control the Elewave Series. The support software is for inputting data to the controller.	
	How much force applied to the table will cause a missed step?	A missed step may occur if force at or above 60 % of the maximum stroke (rotary), maximum gripping force (hand), or maximum thrust (NS slider) is applied.	
	Can the relay cable (robot cable) be extended?	Generally do not extend the cable, as doing so will decrease its noise resistance.	
	Can multiple actuators be controlled with a single controller?	One actuator is controlled with a single controller.	
	Are clean room specifications supported?	We provide main units with special low-dust grease.	
	Is the cable protruding from the main unit the robot cable?	The cable protruding from the main unit is not the robot cable. Make sure to secure it for use. Failing to secure it may cause a wiring disconnection.	
	What are POS0 to POS5 displayed in the support software?	They indicate the I/O input state when moving the position. The Elewave Series enables a total of 64 arbitrary points to be set with binary combinations of POS0 to POS5. * Binary combinations of POS0 to POS4 for EW2C. This equates to a total of 32 points.	
	What is an origin shift?	An origin shift is the act of shifting from the coordinate values of the origin return complete position the amount entered in the parameter. The position after the shift is the zero position. Even when an origin shift is set, it always moves to the original origin position before performing the origin shift, after entering the origin return command.	
	Is position detection available?	Yes. Position detection can be performed using the "@?POS" communication command, but since there is a time lag, the position when stopped is generally detected.	
	What is the level of noise resistance?	The EWHC is level 2 of IEC61000-4-4 and the EW2C is level 3 of IEC61000-4-4.	
	What is the INPOS control output signal?	This signal means that movement to the specified position is complete when moving an actuator.	
	What is the HOLD control output signal?	This signal means that the operation is complete after gripping or pushing the workpiece when using an electric hand or NS slider.	
	Does the support software change with newer versions?	The content of the support software is subject to change. The latest version of the support software can be downloaded from the KOGANEI website.	
	Can the type of alarm be checked when an alarm occurs?	Communication can be performed to check the alarm history.	
	Pulse array controller	How bend resistant is the robot cable?	The bend resistance is about 5 to 10 times that of regular cables (the cable protruding from the main unit is not bend resistant).
		How flexible is the robot cable?	The fixed bend radius is 4 times that of the cable diameter and the movable bend (including cable bear) radius is 8 times or more that of the cable diameter.
Can the main unit be installed in locations subject to vibrations?		Avoid installing in locations subject to vibrations of 4.9 m/s ² [0.500 G] or stronger.	
What is the actuator number?		The actuator number is a number required when entering data suitable for an actuator. Make sure to enter the appropriate value, as the actuator will not operate correctly if the actuator number is incorrect.	
What kind of methods are available for the pulse input method?		The open collector method and line driver method are supported.	
What kind of methods are available for the pulse array input instruction format?		The CW/CCW method or pulse/code method are supported.	
What are the I/O functions of the pulse array controller?		Available functions include the origin return operation, brake control, positioning complete signal, zone output, clear counter, and gripping mode transfer functions.	
What happens if a pulse exceeding the maximum pulse speed is input?	A missed step may occur in the main unit.		
What happens if a pulse exceeding the maximum pulse rate is input?	A missed step may occur in the main unit.		
Is point input operation available with the pulse array input controller?	No.		

Item	Question	Answer
Electric hand	What happens if there is an obstacle before the specified point when performing positioning (A, I mode)?	The EWHA * emits an overload alarm and stops. The EW2H * emits a time over alarm and stops.
	What is the gripping force mode (C, O)?	The C, O mode performs gripping force control. When editing data, the gripping level can be set to grip the workpiece softly.
	What happens if there is a power failure while retaining a workpiece?	The EWHA * cannot retain the gripping force. The workpiece may fall, depending on the conditions. The EW2H * has a self-lock mechanism to prevent the workpiece from falling. However, it cannot retain the gripping state.
	Is intermediate setting of the gripping force level possible?	The EWHA * can be set to one of 10 levels. The EW2H * can be set to one of 5 levels.
	Can I detect when a workpiece falls during workpiece gripping?	The HOLD signal can be monitored to detect this situation, as the HOLD signal will turn off.
	Is gripping possible at a grip point of 50 mm [1.969 in.] or higher?	It is possible as long as the gripping force is controlled to be at or below the allowable moment.
	Is use possible in the horizontal orientation?	Yes. However, make sure that control is at or below the allowable moment.
	What is the minimum setting distance?	The distance is 0.01 mm [0.0003 in.] for EWHA * . The distance is 0.05 mm [0.002 in.] for EW2H * .
	Does the operation time change according to the load?	The operation time does not change according to the load. The operation time is changed using the speed setting in the point data. * With the EW2 Series, the operation time changes slightly according to the load.
	Can gripping force control be managed using numeric values instead of the level setting?	No.
What is judgment output?	Judgment output is a function for detecting workpieces of a specified size. The INPOS signal is output when the gripping position is within the set range.	
What is the cylinder thrust for the positioning mode?	It is equivalent to the maximum level for the gripping mode. However, gripping cannot be performed in the positioning mode.	
Is maintenance required?	No particular maintenance is required, but use lithium grease when greasing.	
NS slider	Can a brake be used?	A brake cannot be used, for structural reasons.
	What is the minimum setting distance?	The distance is 0.01 mm [0.0003 in.].
	What is judgment output?	Judgment output is a function for detecting workpieces of a specified size. The INPOS signal is output when the pushing position is within the set range.
	Can pushing force control be managed using numeric values instead of the level setting?	No.
	What is the drive mechanism?	The drive mechanism has a rack and pinion structure.
	What is the cylinder thrust for the positioning operation?	It is equivalent to level 10 for the pushing operation. However, pushing cannot be performed in the positioning mode.
	Is maintenance required?	No particular maintenance is required, but use lithium grease when greasing.
What material is used for the major parts?	Table: Aluminum alloy (anodized) Main unit: Aluminum alloy (anodized)	
Electric rotary actuator	What is the minimum angle setting?	0.01 degrees.
	The acceleration is automatically set according to the load inertia. Does changing the inertia affect the displayed acceleration?	It changes according to the inertia. Change the value to further reduce the value where the displayed acceleration is 100 %,
	What is the minimum operation time?	It differs according to the main unit size. For information on the minimum operation time, check the specifications in the catalog.
	Is continuous rotation possible?	One rotation (360°) is set by default. The parameter can be changed to up to 90 continuous rotations (maximum 32400°).
	What is the maximum mass moment of inertia for the load that can be attached to the table?	Check the maximum load inertia in the catalog specifications.
	Are there any limitations to the installation direction of the main unit?	No. It can be installed any way up.
What is the maximum load mass?	Calculate the mass moment of inertia rather than the mass of the load. Ensure that the mass moment of inertia is at or below the maximum load inertia.	

EW2H

EW2HL

EWHA □ A

EWHA □ H

EWHRT

EWM5

Material

Frequently Asked Questions

Item	Question	Answer
Electric rotary actuator	What is the drive system?	A spur gear system is used.
	What kind of drive system is a spur gear system?	Spur gears are the most common type of gear. However, the product has a special structure for eliminating backlash.
	What is the brake option?	The brake option is used for preventing falls, etc. when the product is wall-mounted. Select the brake option when the product is wall-mounted, as the rotation axis will be free when the power is turned off if there is no brake, due to the structure of the main unit. *EWHRT1A is not available with brakes.
	What is the external force (torque) applied in the table rotation direction when stopped?	It is within 60 % of the maximum torque.
	Are there any limitations to the operating frequency?	Use the product with a DUTY of 50 % or less.
	What can be passed through the ϕ 6 [0.236] hollow shaft?	The following air tubes and sensor switches for KOGANEI cylinders can be passed through. <ul style="list-style-type: none"> • ϕ 1.8 [0.071] tube x 3 • ϕ 1.8 [0.071] tube x 1 + ϕ 4 [0.157] tube x 1 • ϕ 1.8 [0.071] tube x 1 + sensor x 1 • Sensor x 2
	What can be passed through the ϕ 12 [0.472] hollow shaft?	The following air tubes and sensor switches for KOGANEI cylinders can be passed through. <ul style="list-style-type: none"> • ϕ 1.8 [0.071] tube x 6 • ϕ 1.8 [0.071] tube x 3 + sensor x 2 • ϕ 1.8 [0.071] tube x 1 + ϕ 4 [0.157] tube + sensor x 2 • ϕ tube x 3
	How does the allowable load change when the table surface is installed on the bottom?	The allowable load is the same as with table top surface installation.
	Is the table displacement added when the table is moved in the same direction with the I mode?	The displacement is not added when the table is moved in the same direction, because the displacement is not included in the specified value.
	Is maintenance required?	No.
What material is used for the major parts?	Table: Aluminum alloy (anodized) Main unit: Aluminum alloy (anodized)	

Troubleshooting

For information on the errors and alarms, see the instruction manuals for each model.

Elewave Series Glossary

	Term	Description
A	Absolute	The absolute position. The position (coordinate values) from the reference point.
	Actuator number	A system that enables the controller configuration settings to be easily changed to match the specifications of the main unit type to connect. A number is assigned for each main unit type, and that number can be entered when initializing the controller to automatically change the parameters in the controller to match the required specifications.
	Alarm message	An alarm emitted by the controller when there is a problem. An alarm is being emitted when the READY output is OFF in the dedicated output. This is caused by a symptom such as wiring disconnection or data damage.
	Alarm reset input (ALR)	Input during the alarm state (READY: OFF, ALARM LED: ON) to cancel the alarm. *Pulse array input type only
	Allowable moment	When a workpiece with a center of gravity away from the table center position of the slider is placed, force is applied to the table in the rotation direction. This turning force is called the moment, and an allowed value is set for the force in the rolling (Mr), pitching (Mp), and yawing (My) directions.
B	Brake release input (BRK)	Input to release the brake mechanism of the actuator. *Pulse array input type only
C	Clear counter entry (CCLR)	Resetting the counters in the controller (encoder count, energizing count, and deviation count). *Pulse array input type only
	Closed loop control	A method where feedback on the state of the object being controlled is given and the various control processes are proceeded with according to the obtained conditions. With an electric actuator, the current position information from the encoder is fed back to the controller to perform error compensation.
	Communication command	A statement for performing operations by connecting to a controller or external device with a communication function such as a computer. The communication commands of the Elewave Series are divided into four major categories: 1. Robot language, 2. Data handling, 3. Utility, and 4. Special code.
	Communication function	The function that enables setting changes and operations from an external device. Generally, a device such as a computer is used as the external device, and serial communication such as RS-232C is often used for connections.
D	Dedicated command input	Input for controlling from external devices such as a programmable controller.
	Dedicated output	Output for exchanging signals with external devices such as a programmable controller.
	Duty	The ratio of time that a periodic phenomenon continues for over a certain period. In an electric actuator, means the ratio of operation time per cycle (the rate of operation).
E	EEPROM	A type of semiconductor memory that enables the device user to electrically write and erase the ROM. An abbreviation for Electrically Erasable PROM.
	Encoder Z phase	A signal emitted once each rotation of a rotary encoder that is used as the origin position within a single rotation. Encoder signals other than the Z phase include the A phase and B phase for checking the actuator movement using the phase difference.
	Error message	An error emitted by the controller when there is a usage mistake. This is caused by a symptom such as an incorrect command or origin incomplete.
	Executing command output (BUSY)	The output signal turned ON while executing a dedicated command or executing a command from a computer. A controller with this signal turned ON does not receive other dedicated command input or commands from a computer.
G	Grip point	The distance from the table surface of the hand to the center gripping position of the actual workpiece.
	Gripping complete output (HOLD)	The output signal that turns ON when the gripping operation successfully completes. It temporarily turns OFF when a dedicated command, etc. is received, then turns ON when the execute operation successfully completes.
	Gripping force	Force for holding something securely or gripping something tightly.
	Gripping mode transfer input (PRESS)	Input to transfer the actuator to the gripping mode. *Pulse array input type only
	Grounding	Connecting a device chassis, neutral point of an electric line, or reference potential wiring of an electronic device to a reference potential point with an electrical conductor, or that reference potential point itself. The name grounding refers to the fact that the ground was used as the reference point in the past, but the meaning has been extended to also refer to cases where the ground is not used. Also called earth or ground.
I	Increment	The relative position. The amount to move from the current position or the movement position.
J	Judgment output	A function that outputs when a measurement value is within the range of a set threshold.
L	Length measurement function	The function for using the communication function to read the current position data of the encoder. With the Elewave Series, the @?POS communication command can be used to read the current position.
	Linear guide	A component that utilizes ball rolling to perform linear motion. A ball is used between the rail and block to perform linear motion via rolling contact.
	Load inertia	The mass moment of inertia for the load. With a rotary actuator, the workpiece mass moment of inertia must be kept below the maximum load inertia in the specifications.
	Lost motion	Positioning is performed in the positive direction (the motor rotation clockwise direction) for an arbitrary position (the measurement position for reference) and the position is measured. After moving in the positive direction, positioning is performed the same amount in the negative direction (the motor rotation counterclockwise direction) and the position is measured. The difference in positions is called the lost motion.

EW2H

EW2HL

EWA □ A

EWA □ H



EWHRT

EWM5

Material

Elewave Series Glossary

M	Maximum tightening torque	The maximum torque for tightening screws and bolts when performing tightening for securing the main unit and jig, etc.
	Microstep	Types of stepping motor control include full step, half step, and microstep, which enables the step angle (the angle to move for a single pulse) to be specified in detail. This improves resolution and has the benefit of reducing vibrations and noise.
	Missed step detection	A missed step is the state where a pulse motor such as a stepping motor does not rotate despite a pulse being sent. This is caused by high-speed rotation or high loads, and displacement occurs after it happens. To counter this, a rotary encoder is used to detect whether the motor is rotating correctly according to the pulse output.
	Multi-point positioning operation	A characteristic of electrical products, where point data can be used to stop at multiple positions. Enables complex operations that are not reciprocation between two points.
N	Noise resistance	The standard interference resistance of locations affected by noise that interferes with required signals. The Elewave Series complies with level 2 of the IEC61000-4-4 international standard. *EW2C is IEC61000-4-4 Level 3
O	Origin incomplete	The state where recognition of the origin position is lacking, such as immediately after turning the power ON or after an emergency stop. The state where origin return is required.
	Origin return	With increment devices, the origin position needs to be reconfirmed when the power is turned ON because the origin of each actuator in the coordinate data is lost when the power is turned OFF. That operation is called origin return. There are two methods for origin return: the sensor method and the contact method.
	Origin return signal (ORG)	The dedicated command input signal for returning to the origin in the origin return direction specified in the parameters.
	Origin return stop/pulse input prohibited input (STOP/PPRO)	The input signal for canceling the origin return during origin return. When this input signal is received in other states, the controller prohibits pulse array input. *Pulse array input type only
	Origin shift	Shifting the origin position of coordinate data to an arbitrary position. Also called virtual origin.
	Overhang	The state where the center of gravity of the object being transported overhangs from the center position of the top of the actuator slider in the front/back, left/right, or up/down direction.
	Overload	The state where load in excess of the allowed load is applied to a movable part of a machine.
P	Parameter	A value for setting the operating conditions of an electronic device. In the Elewave Series, parameters are used to easily set the controller environment and specifications in software instead of hardware adjustment mechanisms such as potentiometers and switches.
	Photocoupler	A type of element for conveying electrical signals, which includes a light emitting element (light emitting diode) and light receiving element (phototransistor) and is enclosed in a package that blocks out external light. A photocoupler converts the input electrical signal into light and conducts the light receiving element with that light to achieve signal transmission.
	Pitching (Mp) allowable moment	The allowable moment in the pitching direction. 
	Point data	The travel distance data or coordinate data for performing differential motion for positioning.
	Point input method	The method for entering point data. The Elewave Series has three methods: the teaching box method, support software method, and communication function method.
	Point setting input (POS0 to POS5)	Dedicated command input for connecting to an output circuit such as a programmable controller (PLC) and specifying a point number.
	Positioning A mode	A mode (absolute operation) that performs acceleration/deceleration to move to the position of the specified point with the coordinates of 0 as the origin position, and then stops.
	Positioning complete output (INPOS)	The output signal that turns ON when the positioning operation successfully completes. It temporarily turns OFF when a dedicated command, etc. is received, then turns ON when the execute operation successfully completes.
	Positioning complete/pushing gripping operation complete output (INPOS/HOLD)	When PRESS input is OFF, the signal for positioning complete. When PRESS input is ON, the signal for pushing/gripping operation complete. *Pulse array input type only
	Positioning I mode	A mode (increment operation) that performs acceleration/deceleration to move from the current position the amount specified by the data specified in the point, and then stops.
	Preparations complete output (READY)	The output signal for checking whether the system of the controller is operating normally. This signal is normally ON. When an alarm occurs, the signal is turned OFF and the motor enters the non-energized state. The power needs to be restarted to perform recovery.
	Pulse array input	The operation direction for inputting a pulse signal to a motor to perform a predetermined movement (stroke/rotation angle). The pulse signal input can adjust the amount to move and the acceleration/deceleration.
	Pulse array input instruction format	The pulse waveforms from host equipment are divided into three types (CW/CCW method, pulse/code method, and A phase B phase pulse input method). Elewave controllers support the CW/CCW method or pulse/code method.
Pulse array input method	The pulse output methods from host equipment include the (differential) line driver method and open collector method. The (differential) line driver method outputs the output signal and a signal that reverses the polarity of the output signal, and uses that difference as the signal. In recent years, the (differential) line driver method has often been used because of its superior noise resistance.	

P	Pulse array receivable output (ENABLE)	The output signal turned ON when the controller is in the state for receiving pulse array input. *Pulse array input type only
	Pulse signal	A square wave electrical signal.
	Pushing/gripping C mode	The mode that operates to the close side at a constant speed and pushes/grips at the set force.
	Pushing/gripping O mode	The mode that operates to the open side at a constant speed and pushes/grips at the set force.
R	Radial load	The load applied to the rotation axis in the perpendicular direction.
	Repeated positioning precision	The displacement that occurs when repeatedly moving to an arbitrary point (the measurement point for reference) in the same direction.
	Robot cable	A cable with high bend resistance that is used for the moving parts of machine tools and industrial robots. The general term for highly durable cables that have passed cable reciprocation bending tests, cord reciprocation bending tests, and cable twisting tests, etc.
	Rolling (Mr) allowable moment	The allowable moment in the rolling direction. 
	Rotary encoder	An encoder is a device that encodes data values into target codes according to defined rules. The encoder in an electric actuator is attached to the rotation shaft of a motor to act as the sensor for the rotation angle (travel distance) and rotation direction, etc.
S	RS232C	A serial communication standard established by the U.S. Energy Information Administration (EIA), which is the most common standard for serial communication. The maximum cable length is approximately 15 m [49.213 ft.] and the maximum communication speed is 115.2 kbps. D-sub 25 pin or D-sub 9 pin connectors are often used.
	Servo ON signal (SRVO)	The input signal for energizing the motor. When the servo is ON, the ENABLE signal is turned ON and pulse array input can be received. The energizing counter and encoder counter are cleared at the same time. *Pulse array input type only
	Shock-free start and stop	The Elewave Series utilizes acceleration/deceleration control, which is an advantage of electrical products, to enable gentle acceleration/deceleration that reduces the shock of the moving speed at the start point and end point. This function enables smooth transition to the top speed.
	Size detection function	The function for externally outputting the position data when pushing/gripping operation is complete in the pushing/gripping mode and the data is within the set range.
	Soft limit	A soft limit ensuring that something does not proceed past a certain stroke.
	Start signal input (START)	Dedicated command input for moving from the current position the amount indicated in the point number data specified in POS0 to POS5. *EW2C is from POS0 to POS4
	Stepping motor	A motor that performs angle positioning proportional to the input pulse signal with open loop control.
	Stop signal input (STOP)	The dedicated command input for temporarily stopping the movement of an actuator.
T	Thrust (gripping force) control	Controlling the pushing force (thrust) in the pushing operation. The ability to push with constant thrust is one characteristic of electric products.
	Thrust load	The load applied in the axis direction.
	Timing chart	A line chart indicating the temporal change of input and output signals.
	Torque	The turning force that occurs around the rotation axis when rotary motion is applied to the center of a rotation axis where an object is secured. Also called the twisting moment. The torque is expressed as the product of the force and distance. The unit used is N·m (Newton meters).
	Twisted pair cable	A cable that combines a pair of twisted electric wires, also called a twisted pair wire. More resistant to noise than a simple straight wire.
	Type 3 (type D) grounding	Grounding where the resistance is 1,000 or less when low pressure equipment of 300 V or less is installed and the wire width is at least 1.6 mm [0.063 in.]. There are four types of grounding: Type A to type D.
U	U mode	Performs acceleration/deceleration movement and adds gripping operation.
W	With brake	The type that mechanically secures the table when the power is turned OFF. With the standard type (without brake), the table is in the free state when the power is turned OFF. This option can be selected for the EWHRT3A, 5A, 10A, 20A, 40A, 60A rotary actuators.
	Yawing (My) allowable moment	The allowable moment in the yawing direction. 
	Zone output function	The pulse array input type function of the Elewave Series. The function for storing two points of position data to a controller to turn the ZONE output ON via I/O when the actuator moves between those two points. A zone range can be set for up to four locations.

Operating Method

1. Size detection function (electric hand)* Effective for determining whether workpieces are faulty for point input type and CC-Link type controllers only. The minimum setting range is 0.01 mm [0.0003 in.], (0.05 mm [0.002 in.] for the flat type)
 Example) When workpiece (2) is not faulty and workpieces (1) and (3) are faulty.

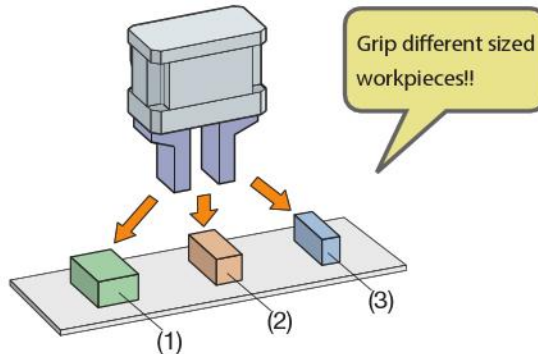

○ **When general gripping control is performed**
 The workpiece is gripped with a constant force. Workpiece gripping is possible by performing gripping control. However, since the same signal is output regardless of the workpiece that is gripped, whether a workpiece is faulty cannot be determined, only whether a workpiece is gripped.

Signal output state

Dedicated output	(1)	(2)	(3)
READY	ON	ON	ON
BUSY	OFF	OFF	OFF
INPOS	OFF	OFF	OFF
HOLD	ON	ON	ON

*The same signal is output for all workpieces.

○ **When the size detection function is used**
 By inputting the dimensions of non-faulty workpieces to the controller in advance, a different signal can be output when a faulty workpiece is gripped.

⇒ **Workpiece identification is possible with signal monitoring!**

Signal output state

Dedicated output	(1)	(2)	(3)
READY	ON	ON	ON
BUSY	OFF	OFF	OFF
INPOS	OFF	ON	OFF
HOLD	ON	ON	ON

*The INPOS signal can also be turned ON when the workpiece is within the range for a non-faulty workpiece, and that signal can be received by an external device to perform workpiece judgment!!

***The size detection function can be controlled not only on the closed side but also on the open side.**

Remarks: With the NS slider, the same check can be performed by pushing.

2. Workpiece Size Measurement Function (Electric Hand)

Communication with a computer can be used to detect the position where the fingers are gripping the workpiece. A communication command can be used to calculate the difference between the read value and the effective stroke on the computer and thereby measure the size of the gripped workpiece.
 Communication command to use: "@?POS" (the command for reading the current position)

Example) Detecting the size of each workpiece on a line where workpieces of unknown size flow
 After using an electric hand with the gripping mode to complete gripping of the workpiece, use RS485 or RS232C communication to read the gripping point.

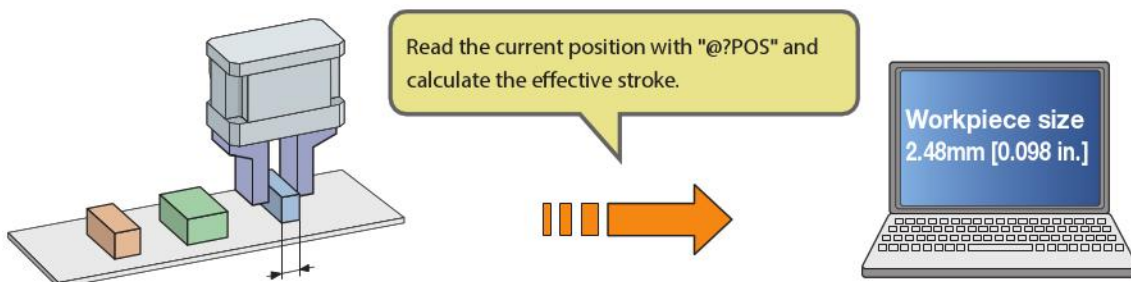

Caution: The precision of dimension measurement depends on the grip point of the workpiece and the precision of the claws attached to the guide.

***The workpiece size measurement function can be controlled not only on the closed side but also on the open side.**

Remarks: With the NS slider, the same check can be performed by pushing.

3. Workpiece gripping check function (electric hand) *Point input type and CC-Link type controllers only

Whether the workpiece is gripped can be determined when executing the gripping operation.

Whether gripping is performed can be checked by monitoring the I/O output state.

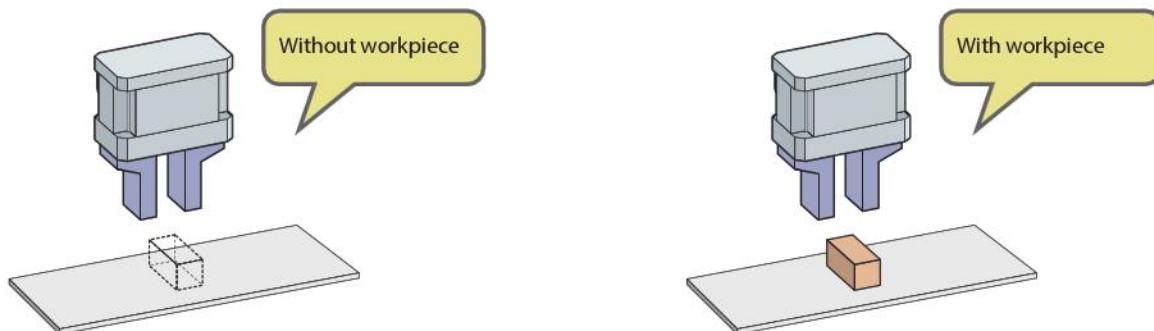

○ If there was no workpiece when the gripping operation was performed

Signal output state

Dedicated output	During operation	When operation is complete
READY	ON	ON
BUSY	ON	OFF
INPOS	OFF	OFF
HOLD	OFF	OFF

* When using the communication function, an error (stop limit) is displayed.

○ If the workpiece was gripped normally

Signal output state

Dedicated output	During operation	When operation (gripping) is complete
READY	ON	ON
BUSY	ON	OFF
INPOS	OFF	OFF
HOLD	OFF	ON



Caution: When using an electric hand with claws attached, it is necessary to adjust the soft limit by changing the parameter data in order to determine whether a workpiece exists before the slider reaches the stroke end.

Remarks: With the NS slider, the same check can be performed by pushing.

4. Zone output function (NS slider) *Pulse array input type controller only

When moving an actuator, output can be turned ON when the range set in the controller in advance is passed through.

Zone output is a function for freely setting a range within a stroke and outputting a signal when the slider moves that range. This can be utilized for the interlock and timing of peripherals, etc. There is a total of four zone data items.

Example) Simple dispense for straight line movement

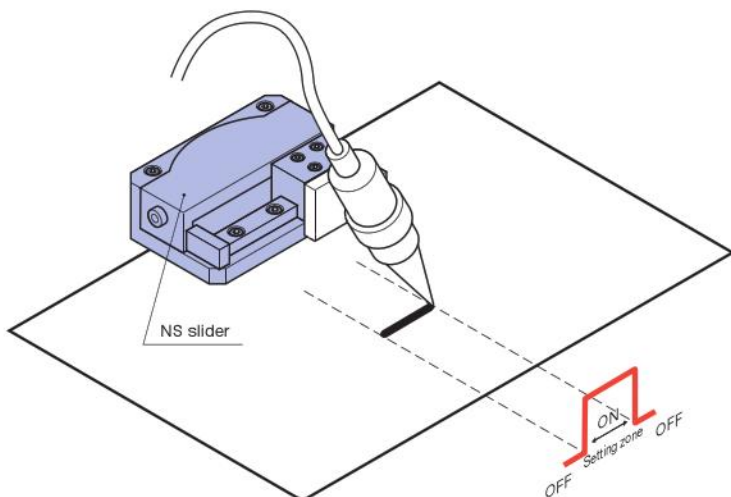

Remarks: The zone output function can also be used when using an electric hand or electric rotary actuator with a pulse array input type controller.

Electric Actuator and Controller Correspondence Chart

Additional part type		Controller					Teaching Box		Relay cable			
		EW2C-H-NP EW2C-H-PN	EW2C-H-CC EW2C-H-CCD	EWHC(P)-NH	EWHC(P)-RA	EWHC(P)-RS	EW2TB	EWHTB	EW2KA	EWHKA		
Electric hand	flat type Standard stroke	EW2H8	○	○	-	-	-	○	-	○	-	
		EW2H18	○	○	-	-	-	○	-	○	-	
		EW2H28	○	○	-	-	-	○	-	○	-	
	flat type Long stroke	EW2HL8	○	○	-	-	-	○	-	○	-	
		EW2HL18	○	○	-	-	-	○	-	○	-	
		EW2HL28	○	○	-	-	-	○	-	○	-	
	Standard type	EWHA12A	-	-	○	-	-	-	○	-	○	
		EWHA24A	-	-	○	-	-	-	○	-	○	
		EWHA36A	-	-	○	-	-	-	○	-	○	
		EWHA6H	-	-	○	-	-	-	○	-	○	
		High-speed type	EWHA12H	-	-	○	-	-	-	○	-	○
			EWHA24H	-	-	○	-	-	-	○	-	○
	EWHA36H		-	-	○	-	-	-	○	-	○	
	NS slider	EWM5HSA	-	-	○	-	-	-	○	-	○	
EWM5HLA		-	-	○	-	-	-	○	-	○		
EWM5SSA		-	-	○	-	-	-	○	-	○		
EWM5SLA		-	-	○	-	-	-	○	-	○		
Electric rotary actuator	EWHRT1A	-	-	-	-	○	-	○	-	○		
	EWHRT3A(-B)	-	-	-	○	-	-	○	-	○		
	EWHRT5A(-B)	-	-	-	○	-	-	○	-	○		
	EWHRT10A(-B)	-	-	-	○	-	-	○	-	○		
	EWHRT20A(-B)	-	-	-	○	-	-	○	-	○		
	EWHRT40A(-B)	-	-	-	○	-	-	○	-	○		
EWHRT60A(-B)	-	-	-	○	-	-	○	-	○			

Electric Actuator and Auto Hand Changer Combination Chart

Auto hand changer	Electric hand flat type	EW2H(L)8	EW2H(L)18	EW2H(L)28
MJC3		●	●	-
MJC10		-	●	●
MJC20		-	-	●
MJC60		-	-	-
MJC100		-	-	-
MJC150		-	-	-

●: Direct mounting possible

-: Direct mounting not possible

Elewave Series Compatibility Chart

EW2H

EW2HL

EWHA □ A

EWHA □ H

EWHRT

EWM5

Material

How to read the chart

Example) When using a combination of controller type "EWHC-NH (from V2.00) + EWHKA-□L" and main unit type "EWM5□□ A", the compatibility chart below indicates "○", meaning that the combination is available.

Main unit type	Actuator number	Controller type (version) + cable type			
		EWHC-H (to V1.01) + EWHK-□L	EWHC-H (from V1.02) + EWHK-□L	EWHC-NH (from V2.00) + EWHK-□L	EWHC-NH (from V2.00) + EWHKA-□L
EWM5□□	30, 31, 32, 33	○ ^{*1}	○ ^{*1}	○	x
EWM5□□A		○ ^{*1*2}	○ ^{*1*2}	○ ^{*2}	○

Corresponding box

*1 A controller upgrade is required.

*2 Must be used in combination with the "EWTK" conversion cable. (For inquiries about the "EWTK" conversion cable, contact your nearest KOGANEI sales office or the KOGANEI overseas group.)

● Meaning of symbols

If "○" is indicated for a combination, that combination is available.

If "*" is indicated for a combination, that combination is available by adding a component or upgrading the controller, etc.

If "x" is indicated for a combination, that combination is not available. For details, contact your nearest KOGANEI sales office or the KOGANEI overseas group.

● Precautions

The compatibility chart is current as of January 15, 2008.

Products available as of January 15, 2008 are indicated in red.

1. Electric rotary actuator

(1) Point input type controller

Main unit type	Actuator number	Controller type (version) + cable type				Main unit cable Length	Compliant with RoHS directive
		EWC-R + EWK-□L	EWHC-R + EWHK-□L	EWHC-RA + EWHKA-□L	EWHC-RS + EWHKA-□L		
EWRT3	60	○	○	x	x	250 mm [9.843 in.]	x
EWHRT3, 5, 10, 20	61, 62, 63, 64	x	○	x	x	100 mm [3.937 in.]	○ ^{*3}
EWHRT3A, 5A, 10A, 20A	61, 62, 63, 64	x	○ ^{*2}	○	x	100 mm [3.937 in.]	○
EWHRT40A, 60A	65, 66	x	○ ^{*1*2}	○	x	100 mm [3.937 in.]	○
EWHRT1A	50	x	x	x	○	100 mm [3.937 in.]	○

(2) Pulse array input type controller

Main unit type	Actuator number	Controller type (version) + cable type			Main unit cable Length	Compliant with RoHS directive
		EWHCP-R + EWHK-□L	EWHCP-RA + EWHKA-□L	EWHCP-RS + EWHKA-□L		
EWRT3	60	x	x	x	250 mm [9.843 in.]	x
EWHRT3, 5, 10, 20	61, 62, 63, 64	○	x	x	100 mm [3.937 in.]	○ ^{*3}
EWHRT3A, 5A, 10A, 20A	61, 62, 63, 64	○ ^{*2}	○	x	100 mm [3.937 in.]	○
EWHRT40A, 60A	65, 66	○ ^{*1*2}	○	x	100 mm [3.937 in.]	○
EWHRT1A	50	x	x	○	100 mm [3.937 in.]	○

*1 A controller upgrade is required.

*2 Must be used in combination with the "EWTK" conversion cable. (For inquiries about the "EWTK" conversion cable, contact your nearest KOGANEI sales office or the KOGANEI overseas group.)

*3 Some products not compliant with RoHS directive are shipped.

2. Electric hand

(1) Point input type controller

Main unit type	Actuator number	Controller type (version) + cable type						Main unit cable Length	Compliant with RoHS directive
		EWCH-H + EWK-□L	EWHC-H (to V1.01) + EWHK-□L	EWCH-H (from V1.02) + EWHK-□L	EWCH-NH (from V2.00) + EWHK-□L	EWHC-NH (from V2.00) + EWHKA-□L	EWHC-NH (from V4.00) + EWHKA-□L		
EWH12	83	○	○	○	○	×	×	250 mm [9.843 in.]	×
EWHA12	83	○	○	○	○	×	×	250 mm [9.843 in.] (100 mm ³)	×
	84	×	○ ^{*1}	○	○	×	×	100 mm [3.937 in.]	○
EWHA24	85	×	○ ^{*1}	○ ^{*1}	○	×	×	100 mm [3.937 in.]	○
EWHA36	86	×	○ ^{*1}	○ ^{*1}	○	×	×	100 mm [3.937 in.]	○
EWHA12A	84	×	○ ^{*1,2}	○ ^{*1,2}	○ ^{*2}	○	○	100 mm [3.937 in.]	○
EWHA24A	85	×	○ ^{*1,2}	○ ^{*1,2}	○ ^{*2}	○	○	100 mm [3.937 in.]	○
EWHA36A	86	×	○ ^{*1,2}	○ ^{*1,2}	○ ^{*2}	○	○	100 mm [3.937 in.]	○
EWHA6H	87	×	○ ^{*1,2}	○ ^{*1,2}	○ ^{*1,2}	○ ^{*1}	○	100 mm [3.937 in.]	○
EWHA12H	88	×	○ ^{*1,2}	○ ^{*1,2}	○ ^{*1,2}	○ ^{*1}	○	100 mm [3.937 in.]	○
EWHA24H	89	×	○ ^{*1,2}	○ ^{*1,2}	○ ^{*1,2}	○ ^{*1}	○	100 mm [3.937 in.]	○
EWHA36H	90	×	○ ^{*1,2}	○ ^{*1,2}	○ ^{*1,2}	○ ^{*1}	○	100 mm [3.937 in.]	○

(2) Pulse array input type controller

Main unit type	Actuator number	Controller type (version) + cable type			Main unit cable Length	Compliant with RoHS directive
		EWHCP-NH (from V1.00) + EWHK-□L	EWHCP-NH (from V1.00) + EWHKA-□L	EWHCP-NH (from V3.00) + EWHKA-□L		
EWH12	83	×	×	×	250 mm [9.843 in.]	×
EWHA12	83	×	×	×	250 mm [9.843 in.] (100 mm ³)	×
	84	○	×	×	100 mm [3.937 in.]	○
EWHA24	85	○	×	×	100 mm [3.937 in.]	○
EWHA36	86	○	×	×	100 mm [3.937 in.]	○
EWHA12A	84	○ ^{*2}	○	○	100 mm [3.937 in.]	○
EWHA24A	85	○ ^{*2}	○	○	100 mm [3.937 in.]	○
EWHA36A	86	○ ^{*2}	○	○	100 mm [3.937 in.]	○
EWHA6H	87	○ ^{*1,2}	○	○	100 mm [3.937 in.]	○
EWHA12H	88	○ ^{*1,2}	○	○	100 mm [3.937 in.]	○
EWHA24H	89	○ ^{*1,2}	○	○	100 mm [3.937 in.]	○
EWHA36H	90	○ ^{*1,2}	○	○	100 mm [3.937 in.]	○

*1 A controller upgrade is required.

*2 Must be used in combination with the "EWTK" conversion cable. (For inquiries about the "EWTK" conversion cable, contact your nearest KOGANEI sales office or the KOGANEI overseas group.)

*3 For products after June 2005, 100 mm [3.937 in.].

3. NS slider

(1) Point input type controller

Main unit type	Actuator number	Controller type (version) + cable type				Main unit cable Length	Compliant with RoHS directive
		EWCH-H (to V1.01) + EWHK-□L	EWCH-H (from V1.02) + EWHK-□L	EWCH-NH (from V2.00) + EWHK-□L	EWCH-NH (from V2.00) + EWHKA-□L		
EWMS□□	30, 31, 32, 33	○ ^{*1}	○ ^{*1}	○	×	100 mm [3.937 in.]	○
EWMS□□A		○ ^{*1,2}	○ ^{*1,2}	○ ^{*2}	○	100 mm [3.937 in.]	○

(2) Pulse array input type controller

Main unit type	Actuator number	Controller type (version) + cable type		Main unit cable Length	Compliant with RoHS directive
		EWHCP-NH (from V1.00) + EWHK-□L	EWHCP-NH (from V1.00) + EWHKA-□L		
EWMS□□	30, 31, 32, 33	○	×	100 mm [3.937 in.]	○
EWMS□□A		○ ^{*2}	○	100 mm [3.937 in.]	○

*1 A controller upgrade is required.

*2 Must be used in combination with the "EWTK" conversion cable. (For inquiries about the "EWTK" conversion cable, contact your nearest KOGANEI sales office or the KOGANEI overseas group.)

4. Teaching box

Main unit type	Version	Controller type						Compliant with RoHS directive
		EWC-R	EWHC-R	EWHC-NH	EWHC-R□	EWHCP-R	EWHCP-R□	
		EWC-H	EWHC-H			EWHCP-NH		
EWTB	Ver.1.00	○	○ ³	○ ²	x	x	x	x
	Ver.2.00	○	○	○ ²	x	x	x	x
EWHTB	Ver.1.**	x	○	○ ^{2,4}	○ ¹	○ ^{1,4}	○ ¹	○
	Ver.2.00	x	○	○ ⁴	○ ¹	○ ^{1,4}	○ ¹	○
	Ver.2.01	x	○	○ ⁴	○ ¹	○ ⁴	○ ¹	○
	Ver.3.**	x	○	○ ⁴	○	○ ⁴	○	○
	Ver.4.00	x	○	○	○	○	○	○

*1 A teaching box upgrade is required.

*2 Can be set when the actuator to connect is the EWHA12.

*3 Functions other than the additional controller functions are available.

*4 An upgrade is required when the actuator to connect is the EWHA□H.

Information

Special Specification Products

In addition to the standard products in the catalog, KOGANEI can provide products to meet special specifications. For details on specifications, pricing, and delivery periods, contact your nearest KOGANEI sales office or the KOGANEI overseas group.

Product name	Special specifications	Remarks
Electric rotary actuator	Flange mounting holes	
	Low dust generation grease	
Electric hand	Low dust generation grease	
NS slider	Low dust generation grease	
	Table surface locating dowel pin hole	
	Symmetrically reversed main unit product	
	Symmetrically reversed main unit and table surface locating dowel pin hole	
Relay cable	Length variation	1 m/7 m [3.281 ft./22.966 ft.] variation
Pulse array input cable	Length variation	3 m/5 m/10 m [9.843 ft./16.404 ft./32.808 ft.] variation

Selected Software

Devices can be selected, etc. on the KOGANEI website. Access <http://www.koganei.co.jp>.

"Elewave Series Electric Rotary Actuator Mass Moment of Inertia Check Sheet"

- For checking the load inertia of the electric rotary actuator.

"Elewave Series Takt Calculation Software"

- For calculating the takt of the NS slider, electric rotary actuator, and electric hand.

EW2H

EW2HL

EWHA □ A

EWHA □ H

EWHRT

EWMS









Material

Discontinued Models and Recommended Substitute Models

Regarding Compatibility

The robot cable connector has been changed in accordance with changes to the connector on the main unit side.

The controller side connector has been changed in accordance with changes to the controller specifications.

No.	Product name	Type	Image	Date production stopped	Substitute model
1	Electric hand	EWH12		March 31, 2006	EWHA12A
2		EWHA□		February 29, 2008	EWHA□A
3	Controller for electric hand	EWC-H		March 31, 2006	EWHC-NH
4		EWHC-H		September 30, 2006	
5	Electric rotary actuator	EWRT3		March 31, 2006	EWHRT3A
6		EWHRT□		February 29, 2008	EWHRT□A
7	Controller for electric rotary actuator	EWC-R		March 31, 2006	EWHC-RA
8		EWHC-R		February 29, 2008	

EW2H

EW2HL



EWA □ A

EWA □ H

EWHRT

EWM5

Material

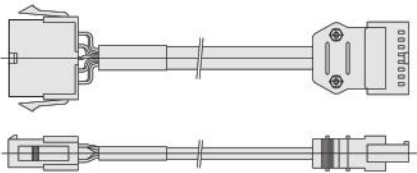
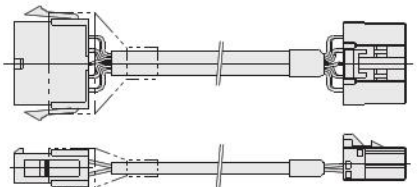
No.	Product name	Type	Image	Date production stopped	Substitute model
9	NS slider	EWM5□□		February 29, 2008	EWM5□□A
10	Teaching Box	EWTB		March 31, 2006	EWHTB
11	Cable (relay cable)	EWK-□		March 31, 2006	-
12		EWHK-□		February 29, 2008	EWHKA-□

Limited Warranty

KOGANEI CORP. warrants its products to be free from defects in material and workmanship subject to the following provisions.

Warranty Period The warranty period is 180 days from the date of delivery.

Koganei Responsibility If a defect in material or workmanship is found during the warranty period, KOGANEI CORP. will replace any part proved defective under normal use free of charge and will provide the service necessary to replace such a part.

Limitations

- This warranty is in lieu of all other warranties, expressed or implied, and is limited to the original cost of the product and shall not include any transportation fee, the cost of installation or any liability for direct, indirect or consequential damage or delay resulting from the defects.

- KOGANEI CORP. shall in no way be liable or responsible for injuries or damage to persons or property arising out of the use or operation of the manufacturer's product.

- This warranty shall be void if the engineered safety devices are removed, made inoperative or not periodically checked for proper functioning.

- Any operation beyond the rated capacity, any improper use or application, or any improper installation of the product, or any substitution upon it with parts not furnished or approved by KOGANEI CORP., shall void this warranty.

- This warranty covers only such items supplied by KOGANEI CORP. The products of other manufacturers are covered only by such warranties made by those original manufacturers, even though such items may have been included as the components.

The specifications are subject to change without notice.

URL <http://www.koganei.co.jp>

E-mail: overseas@koganei.co.jp



KOGANEI CORPORATION

OVERSEAS DEPARTMENT

3-11-28, Midori-cho, Koganei City, Tokyo 184-8533, Japan
Tel: (+81)42-383-7271 Fax: (+81)42-383-7276

KOGANEI INTERNATIONAL AMERICA, INC.

48860 Millmont Drive, suite 108C, Fremont, California 94538
Tel : 1-510-744-1626 Fax : 1-510-744-1676

SHANGHAI KOGANEI INTERNATIONAL TRADING CORPORATION

FM2601-2602, Tongda Venture Building No.1, Lane 600, Tianshan Road, Shanghai, China (200051)
Tel: 86-21-6145-7313 Fax: 86-21-6145-7323

TAIWAN KOGANEI TRADING CO.,LTD

Rm. 2, 16F, No88, Sec. 2, Zhongxiao E. Rd., Zhongzheng Dist., Taipei City 100, Taiwan(ROC)
Tel: 886-2-2393-2717 Fax: 886-2-2393-2719

KOGANEI KOREA CO.,LTD

A-3001, Heungdeok IT Valley Bldg., Heungkeok 1-ro, 13, Giheung-gu, Yongin-si, Gyeonggi-do, 446-908, KOREA
Tel: 82-31-246-0414 Fax: 82-31-246-0415

KOGANEI (THAILAND) CO.,LTD

555 Rasa Tower 1, 12th Floor, Unit 1202 and 1207, Phaholyothin Road, Chatuchak, Chatuchak, Bangkok 10900 Thailand
Tel: 66-2-937-4250 Fax: 66-2-937-4254

KOGANEI AUTOMATION (MALAYSIA) SDN, BHD.

Suite 29-2, Level 29, Menara 1MK, No.1, Jalan Kiara, Mont Kiara 50480, Kuala Lumpur, Malaysia
Tel: 60-12-537-7086

KOGANEI ASIA PTE. LTD.

69 Ubi Road 1, #05-18 Oxley Bizhub Singapore 408731
Tel: 65-6293-4512 Fax: 65-6293-4513