

Electric Auto Hand Changer

Automatically change hands and tools
of robots and automated equipment
without air supply.



Energy saving

Once connected, electric current is not required.

Easy control

Controllable with ON / OFF control.

Slim design

No interference with peripheral devices.

High precision

Repeatability is ± 0.003 mm [0.0001 in.]

Size Variation

Maximum payloads at 3 kg [6.615 lb],
10 kg [22.050 lb], 30 kg [66.150 lb]

Electric Auto Hand Changer

The Electric Auto Hand Changer allows robots and automated equipment to change hands and tools automatically. The Tool Changer can operate under conditions without air supply. This product will support productivity improvement.

Airless

Connect / Disconnect without air source.

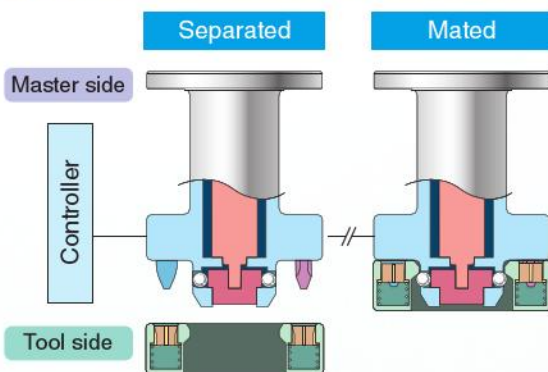

Electric Auto Hand Changer

Master side

Electric Auto Hand Changer

Tool side

Vacuum Pump Unit (example)

* See page 20 for equipment capable of direct installation.



Energy saving

Once connected, electric current is not required.

Easy control

Controllable with ON / OFF control.

Slim design

No interference with peripheral devices.

High precision

Repeatability is ± 0.003 mm [0.0001 in.]

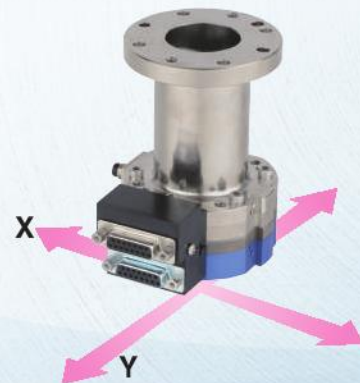

Various electrical interfaces

Solder terminals with cables

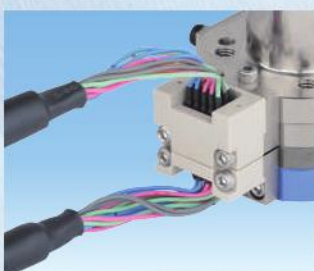

Eliminates on-site soldering work

D-sub connector



Mini-connectors



Non-contact terminals



Suitable for environments with water or cutting fluid

Explanation of operation

Separated state

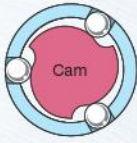

Mated state



Master side

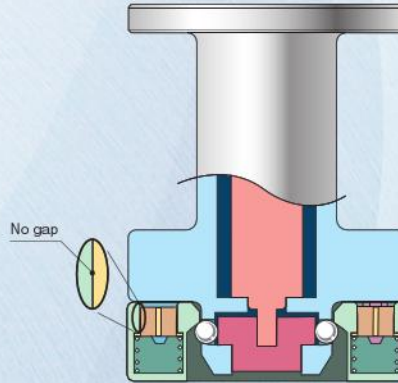
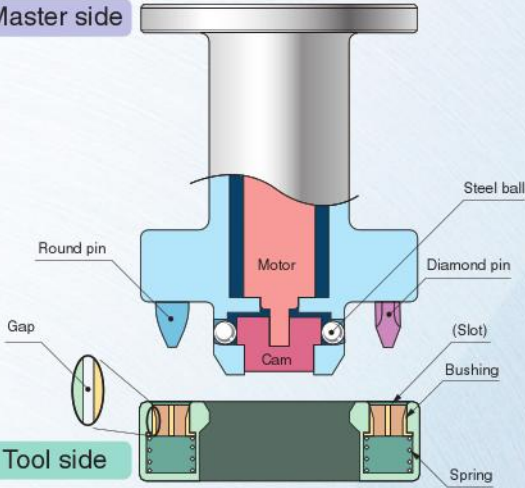

The master side approaches the tool side, and sends a lock signal to the motor.

The cam is rotated by the motor to apply outward force to the steel balls.

The balls engage to lift up the tool side, so the tool side mates to the master side.

When this happens, the round pin/diamond pin mates with the bushing at the tapered surfaces, and the slotted bushings form a tight fit with the tool itself to fix the position.

Once mated, the electric power supply to the motor is cut off.

The self-lock mechanism stops the cam from rotating to maintain the mated state even when force is applied on the tool side.

An unlock signal is sent to the motor.
The cam is rotated by the motor to free the steel balls.
The tool side separates from the master side.

The Electric Auto Hand Changer has an electric interface function to supply electric power and to connect electric signals to the robot's handling end when the handling end is changed.

Separated state

Mated state

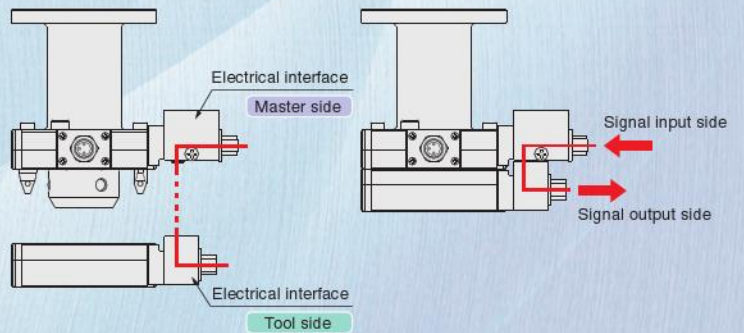

Master side mating surface

Tool side mating surface



Application example for electric auto hand changer

Installed to articulated robot mounted on AGV

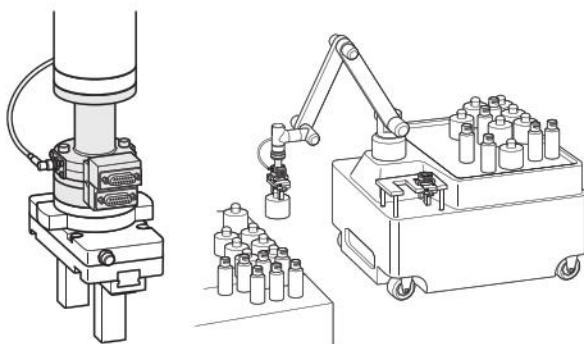



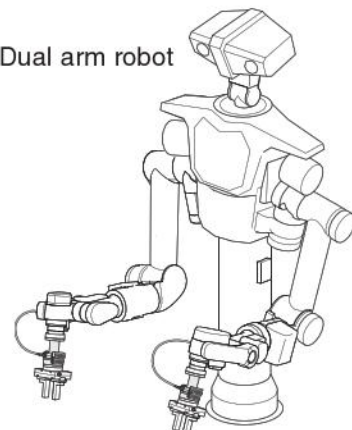

Dual arm robot



Before selecting and using products, please read all the Safety Precautions carefully to ensure proper product use. The Safety Precautions shown below are to help you use the product safely and correctly, and to prevent injury or damage to assets. Be sure to follow the safety rules in JIS B 8433 (safety regulations for industrial robots) as well.

The directions are ranked according to degree of potential danger or damage: "DANGER", "WARNING!", "CAUTION!", and "ATTENTION!".

 DANGER	Indicates situations that can be clearly predicted as dangerous. Death or serious injury may result if the situation is not avoided. It could also result in damage or destruction of assets.
 WARNING	Indicates situations that, while not immediately dangerous, could become dangerous. Death or serious injury may result if the situation is not avoided. It could also result in damage or destruction of assets.
 CAUTION	Indicates situations that, while not immediately dangerous, could become dangerous. Minor or semi-serious injury may result if the situation is not avoided. It could also result in damage or destruction of assets.
 ATTENTION	While there is no chance of injury, these points should be observed for appropriate use of the product.

- This product was designed and manufactured as parts for use in general industrial machinery.
- In the selection and handling of the equipment, the system designer or other responsible person with fully adequate knowledge and experience should always read the Safety Precautions, Catalog, Owner's Manual and other literature before commencing operation. Incorrect handling is dangerous.
- Before using the product, the customer is responsible for verifying and determining that the product is compatible with the customer's system.
- After reading the catalogs, Owner's Manual, etc., always store them where they are easily available for reference to users of this product.
- If transferring or lending the product to another person, always attach the catalogs, Owner's Manual, etc., to the product where they are easily visible, to ensure that the new user can use the product safely and properly.
- The danger, warning, and caution items listed under these "Safety Precautions" do not cover all possible cases. Read the Catalog and Owner's Manual carefully, and always keep safety first.

 **DANGER**

- Do not use the product for the purposes listed below:
 1. Medical equipment related to maintenance or management of human lives or bodies
 2. Mechanical devices or equipment designed for the purpose of moving or transporting people
 3. Critical safety components in mechanical devices
 This product has not been planned or designed for purposes that require advanced stages of safety. It could cause loss of human life.
- Do not use the product in locations with or near dangerous substances, such as flammable or ignitable substances. It could ignite or burst into flames.
- Do not enter the range of machine operations while the product is operating or is in a state in which it can operate. In addition, do not make any adjustments to the interior or to the attached mechanisms while the product is operating. The actuator may move unexpectedly, possibly resulting in injury.
- People who use pacemakers, etc., should stay at least 1 m [3.280 ft] from the product. The magnetic field of powerful magnets inside the product could cause a pacemaker to malfunction.
- When installing the product, always firmly support and secure it (including the workpiece) in place. Injury could result if the product overturns, falls, or is operated abnormally.
- Never attempt to modify the product. Abnormal operation could result in injury, electric shock, or fire, etc.
- Never attempt inappropriate disassembly or assembly of the product relating to its basic inner construction, performance, or functions. Doing so could result in injury, electric shock, or fire, etc.
- Do not splash water on the product. Spraying the product with water, washing it, or using it in water could result in malfunction leading to injury, electric shock, or injury, etc.

 **WARNING**

- Do not use the actuator for equipment whose purpose is absorbing the shocks and vibrations of mechanical devices. It could break and possibly result in injury or in damage to mechanical devices.
- Do not use the product in excess of its specification range. Using the product outside of its specified range could result in product breakdowns, stop of functions, or damage. It could also drastically reduce the operating life.

- Use safety circuits or system designs to prevent damage to machinery or injury to personnel when the machine is shut down abnormally due to emergency stop or power failure.
- Use sufficient shielding measures when using the product in the following locations. If they are not implemented, malfunctions may occur, equipment may be damaged, or injuries could occur.
 1. Locations where large electric currents or magnetic fields are generated
 2. Locations where noise occurs, such as due to static electricity
 3. Locations that could be exposed to radiation
- Before setting up equipment on the product, confirm that the correct installation, wiring, and operating commands are suitable. If the product is used without confirming, there could be interference with moving parts that result in injury or damage to equipment.
- Before supplying electricity to the product and starting operation, always conduct a safety check within the range of machine operations. Unintentional supply of electricity could result in injury caused by electric shock or contact with moving parts.
- Do not touch the terminals or various switches, etc., while the electric power is on. There is a possibility of electric shock and abnormal operation.
- Do not allow the cords or cables to be damaged. Damaging the cords, by excessively bending, pulling, or winding them, or placing heavy objects on them, or pinching them could cause fire, electric shock, or abnormal operation, etc. due to electric leakage or faulty continuity.
- If strange sounds occur or if vibrations are abnormally high, immediately stop operations. Using the product in this state could damage or break the product resulting in erratic or runaway operation.
- Do not throw the product into fire. The product could explode and/or release toxic gases.
- Do not sit on the product, stand on it, or place other objects on it. Doing so creates the risk of injury due to tripping or the product tipping over or falling, and erratic or runaway operation due to damage or breakage to the product.
- When conducting any kind of operation for the product, such as maintenance inspections, repairs, or replacements, always turn off the electricity supply completely.
- Use within the recommended load capacity.

 **CAUTION**

- Do not use the product in locations subject to direct sunlight (ultraviolet radiation), in locations with dust, salt, or iron particles, in locations that are very humid, or in an ambient atmosphere that includes organic solvents, phosphate ester type hydraulic oil, sulfur dioxide gas, chlorine gas, acids, etc. Such uses could lead to loss of functions within a short period, sudden degradation in performance, or reduced operating life.
- Do not use in ambient atmospheres containing corrosive gas, flammable gas, or flammable liquids, etc. There is a risk that rust could occur and degrade strength, or that sparks from the motor could cause an explosion.
- Use only the specified controller with the product. Using an unspecified one could result in product breakdowns or runaway operations.
- Install the main unit and controller in a location where there is little dirt or dust. Installation in a location with excessive dirt or dust could cause malfunctions.
- Do not install in a location subject to extreme vibrations (4.9 m/s² [0.5 G] or greater). Extreme vibrations could cause malfunctions.
- When installing the product, leave room for adequate working space around it. Failure to ensure adequate working space will make it more difficult to conduct daily inspections or maintenance, which could eventually lead to system shutdown or damage to the product.
- Do not bring magnetic media or magnetic memory to within 1 m [3.280 ft] from the product. The magnetic field of the magnets could damage the data in the magnetic media.
- Do not scratch, dent, or deform the actuator by climbing on the product, standing on it, or placing objects on top of it. Doing so could damage or break the product, resulting in operation shutdown or degraded performance.
- Post "Work in Progress" signs when doing installations, adjustments, or other work, so that electricity is not supplied unintentionally. Unintentional supply of electricity could result in injury due to electric shock or sudden operation of the actuator.
- Never conduct an insulation resistance test or dielectric strength test on the controller.
- Do not apply excessive force to the base of the cables of the main unit.
- Do not allow bending moment to be applied to the connectors of the cables of the main unit.

 **ATTENTION**

- When considering using the product for applications that demand extreme safety, such as aviation facilities, combustion equipment, leisure equipment, safety devices, or in other ways predicted to greatly affect assets or human lives, or in situations or environments not described in the Catalog or Owner's Manual, etc., take sufficient safety precautions, such as by allowing ample rating and performance margins for the application and by implementing adequate safety measures, such as fail-safes. Also, be sure to consult us about such applications.
- Use protective covers, etc., to isolate moving parts, such as mechanical equipment, so direct contact with a person's body is not possible.
- Do not arrange controls such that workpieces fall if there is a power failure.
Configure controls to prevent workpieces from falling in case of power failure or emergency stop of the machine.
- Check with the "Owner's Manual" while installing and wiring the product.
- When handling the product, wear protective gloves, safety glasses, safety shoes, etc., as required to maintain safety.
- Conduct daily inspections, and confirm that all requisite system functions are satisfactory, to prevent accidents from happening.
- When the product can no longer be used, or is no longer necessary, dispose of it appropriately as industrial waste.
- For inquiries about the product, contact your nearest Koganei sales office or Koganei overseas department. The address and telephone number are shown on the back cover of this catalog.

 **OTHERS**

- Always observe the following items.
 1. When using this product in a system, always use genuine Koganei parts or compatible parts (recommended parts).
When doing maintenance or repairs, always use genuine Koganei parts or compatible parts (recommended parts).
Always observe the required methods.
 2. Never inappropriately disassemble or assemble the product in relation to its basic construction, performance, or functions.

Koganei bears no responsibility if all safety precautions are not properly observed.

Warranty and General Disclaimer

1. Warranty Period

The warranty period for Koganei products is 1 year from the date of delivery.

* However, some products have a 2-year warranty; contact your nearest Koganei sales office or the Koganei overseas department for details.

2. Scope of Warranty and General Disclaimer

- (1) When a product purchased from Koganei or from an authorized Koganei distributor or agent malfunctions during the warranty period in a way that is attributable to Koganei's responsibility, Koganei will repair or replace the product free of charge. Even if a product is still within the warranty period, its durability is determined by its operation cycles and other factors. Contact your nearest Koganei sales office or the Koganei overseas department for details.
- (2) The Koganei product warranty covers individual products. Therefore, Koganei is not responsible for incidental losses (repair of this product, various expenses required for replacement, etc.) caused by breakdown, loss of function, or loss of performance of Koganei products.
- (3) Koganei is not responsible for any losses or for any damages to other machinery caused by breakdown, loss of function, or loss of performance of Koganei products.
- (4) Koganei is not responsible for any losses due to use or storage of the product in a way that is outside of the product specifications prescribed in Koganei catalogs and instruction manuals, and/or due to actions that violate the mounting, installation, adjustment, maintenance or other safety precautions.
- (5) Koganei is not responsible for any losses caused by breakdown of the product due to factors outside the responsibility of Koganei, including but not limited to fire, natural disaster, the actions of third parties, and intentional actions or errors by the purchaser.



General precautions

Environment

1. Avoid using the main unit, controller, and operation checker in locations subject to dripping water or dripping oil, etc., and in locations that are extremely dusty.
2. Avoid use in locations subject to extreme vibrations or shocks (4.9 m/s^2 [0.5 G] or greater).
3. Stainless steel is used for the ball guides, housing, round pins, diamond pins, and cams, but rust may occur depending on the usage environment. Apply anti-rust oil, etc., if the product is not used for a long period. Refer to the following diagram for the application locations.

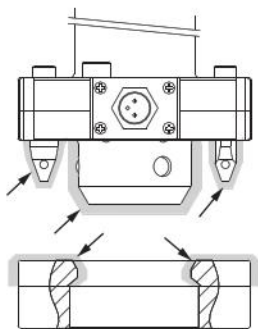

■ : Location to apply anti-rust oil, etc.

4. The motor may become hot under certain operating conditions. Use the Electric Hand within the operating temperature range. Use of the Electric Hand in conditions exceeding the operation limits could result in damage or in burning of the motor.

Mounting

1. The mounting surface must be flat. If the cylinder twists or bends when mounted, not only will it be inaccurate, but there may be defective operation.
2. Note that if the product's mounting surface is scratched or dented it can adversely affect flatness.
3. In cases where loosening of bolts due to impact and/or vibration may be a factor, consider looseness prevention measures. Be careful of overspreading of adhesive. If the adhesive gets into the product, it may cause defective operation.
4. Be careful that mating/unmating operations of the auto hand changer are not obstructed by piping and wiring when mounting hands, etc., to the mounting surface.
5. Tighten mounting bolts to the torque shown on page 9. We also recommend using positioning pins to assure the characteristics of the torsion moment.
6. Arrange the wiring so the cables are not stretched when the robot moves. Otherwise, there is a possibility of defective contacts or disrupted wiring.
7. Install the product so there is adequate space around the controller (20 mm [0.787 in.] or more) with good ventilation.
8. For the controller's ground terminal, use the power cable's F.G. wire.

Wiring

1. Fix the cables so there is no load, such as twisting or pulling, applied to the connectors of the controller and the main unit.
2. The connectors on the main unit may become easy to rotate, depending on their storage and usage environment (highly humid environment). Fix the relay cables so they do not interfere with peripheral equipment, etc., while the product is operating.
3. To change the orientation of the relay cables, remove the 4 small screws from the main unit, and rotate the connector plate as shown in the following diagram. Do not rotate is more than 180° to prevent the internal wiring from tangling. The tightening torque for the small screws is a maximum of 0.18 N·m [1.593 in·lbf].

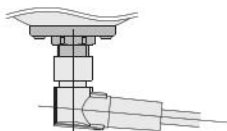
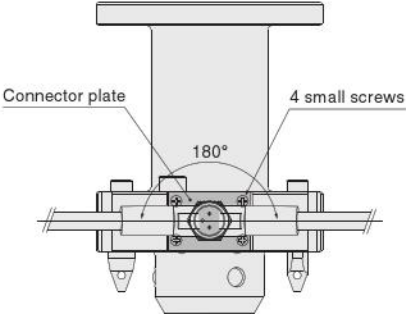

When relay cable is connected on right side

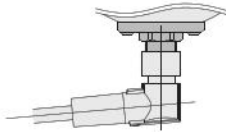

When relay cable is connected on left side

OTHERS

Some operating conditions could cause the operating sound to be louder, but this is not a fault.

Handling Instructions and Precautions

Mating and unmating

<Mating procedure>

- 1 While put in an unlocked state by the controller, bring the master side to above the tool side.
- 2 Bring the master side closer to the tool side, then bring the master side closer until the t dimension is within 0.5 mm [0.020 in.].

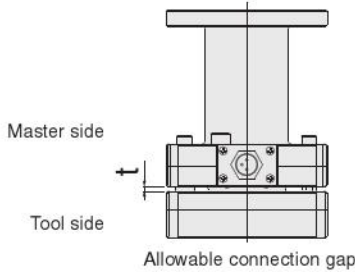

- 3 Use the controller to lock it to finish mating.

<Unmating procedure>

- 1 From a remote position, use the controller to unlock it.
 - 2 Raise the master side so it does not hit the tool side to finish unmating.
1. During mating and unmating operations, do not transmit electric signals from the electrical interface on the master side to the tool side. Doing so causes extreme wear on the electric contacts.
 2. Prevent any dust, etc., from getting between the mating surfaces of the master side and tool side. It degrades the flatness and may affect product life.
 3. When the t dimension is 1 mm [0.039 in.] or less, the following reaction force is generated at the master side and tool side, so consider this when designing peripheral equipment.
EMJ3, EMJ10: 20N
EMJ30: 60N
 4. Doing a lock operation while the t dimension is 0.5 mm [0.020 in.] or less affects the product life and it may not fit tightly.
 5. After the lock operation is finished, the lock sensor output (OLK) from the controller turns ON, but it is not detecting the tight fit on the tool side. If a gap is detected at the mating surfaces, such as foreign matter being pinched between the mating surfaces, then separately prepare a sensor described on page 17, 21, 25.

When teaching

1. When teaching, the positioning error between the master side and the tool side must be within the following ranges.
Note: Set the range of motion without completely fixing the tool side and tool holder.

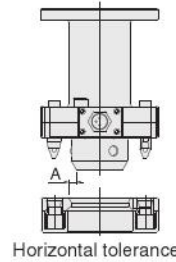

Model	Horizontal tolerance for A (mm [in.])
EMJ3	±3 [0.118]
EMJ10	±3.5 [0.138]
EMJ30	±4.5 [0.177]

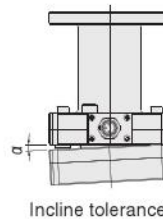

Model	Incline tolerance α (deg)
EMJ3	0.5
EMJ10	0.4
EMJ30	0.3

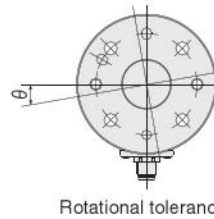

Model	Rotational tolerance θ (deg)
EMJ3	±5.0
EMJ10	±3.5
EMJ30	±4.5

Maintenance (main unit)

1. Periodically clean the mating surfaces of the master side and tool side. Any dirt on them could affect accuracy and product life.

Displacement in relation to bending moment

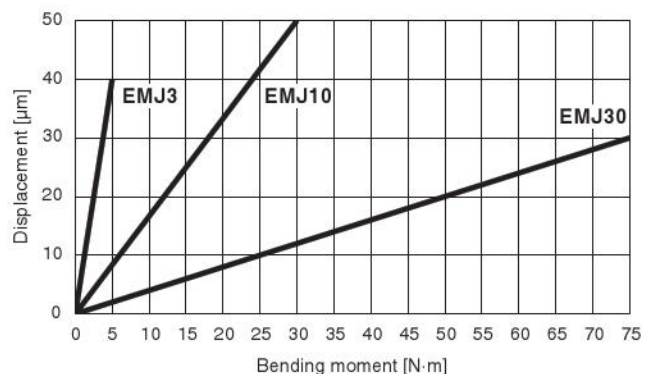
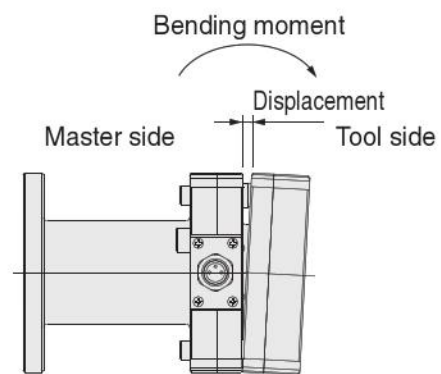

Electrical interface (contact terminals)

● Solder-type terminals

Connect the various probes and contact pins with solder.
Recommended wire diameters: AWG24 or smaller wire diameters

● Solder terminals with cables

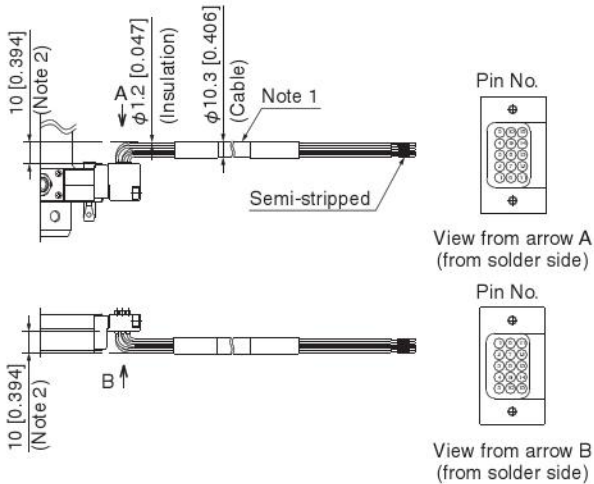

Chart of supported cables

Pin No.	1	2	3	4	5	6	7	8	9	10	11	12	13	14	15
Insulation color	Light blue	Pink	Light green	Orange	Gray	Light blue	Pink	Light green							
Dot mark type	1 line of short dots					2 line of short dots									
Dot color	Black	Red	Black	Red	Black	Red	Black	Red	Black	Red	Black	Red	Black	Red	Black

- Note 1: The following cables are used.
 Hanshin Electric Wire & Cable: MRC UL20276-SB 8P×24AWG (Twisted pair, core wire count: 8P, shielded cable)
 2: When placing an adapter, or other component, on the soldered side of a soldered terminal, consider the allowable bending radius of the wire, and allow a margin of 10 mm [0.394 in.] or more above the soldered terminal.
 3: The * mark in the chart of supported cables indicates twisted pair cables.
 4: The cable's fixed bending radius is 42 mm [1.654 in.] or higher, and the cable's movable bending radius is 62 mm [2.441 in.] or higher.

● D-sub connector

Use D-sub connectors that are equivalent to the following for connections.
 Manufactured by Fujikura: a17JE-23150
 Manufactured by Hirose: RDAB-15P

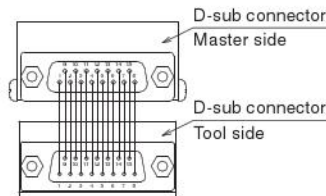

Note 1: The pin numbers for the 15 electric contact pins are connected so they are the same on the master side and the tool side.

● Mini-connectors

We have cables for mini-connectors, but if you are making your cables, use connectors that are equivalent to the following for connections.
 Manufactured by J. S. T. MFG. Connector: GHR-09V-S
 Contact: SSHL-002T-P0.2
 Hand-crimping tool: YRS-1590

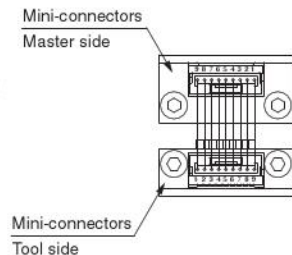

Note 1: The pin numbers for the 9 electric contact pins are connected so that the master side and the tool side are reversed.

● Cable for mini-connectors

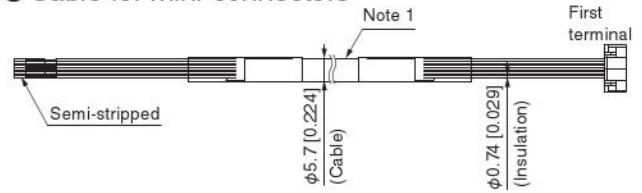

<Master side>
 Model: EMJE-C□M

Chart of supported cables

Pin No.	1	2	3	4	5	6	7	8	9
Insulation color	Blue	White	Yellow	Brown	Green	Black	Red	Gray	Purple

<Tool side>
 Model: EMJE-CAT

Chart of supported cables

Pin No.	1	2	3	4	5	6	7	8	9
Insulation color	Purple	Gray	Red	Black	Green	Brown	Yellow	White	Blue

- Note 1: The following cables are used.
 Oki Electric Cable: ORP-SL0.1SQ×5P(SB)(2464)
 2: The * mark in the chart of supported cables indicates twisted pair cables.
 3: The cable's fixed bending radius is 23 mm [0.906 in.] or higher, and the cable's movable bending radius is 46 mm [1.811 in.] or higher.

Maintenance (electrical interface)

- Periodically clean the electric contacts. If they are dirty, transmission of electric signals becomes difficult.
- If the probe terminal causes poor contact, replace the probe terminal. They are available as additional parts.
 The procedure for changing probe terminals is shown below.

<Extraction method>
 • Hook the tip of the probe, with your fingers or pliers, and then pull it out of the socket.

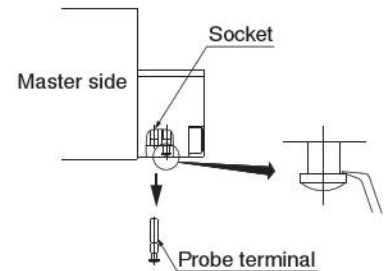

Handling Instructions and Precautions

<Installation procedure>

1. Use your hands to temporarily insert the probe.
 2. Use your hand or a plastic rod to press in the tip of the probe terminal.
- * As you push them in, when you feel the probe terminal fit into the socket, go to step 3. If you apply excessive force continuously, the position of the socket will change and affect performance.
3. Without applying force on the probe terminal, be sure to confirm the tip of the probe is in the position shown below.

Electrical interface	Position of tip of probe terminal
Solder terminals (with cables)	Flush with end of probe holder
Mini-connectors	Flush with end of probe holder
D-sub connector	L=1.2 mm [0.047 in.]

For solder terminals and mini-connectors

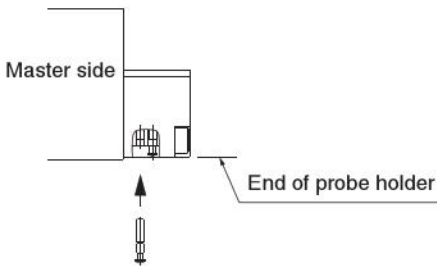

For D-sub connectors

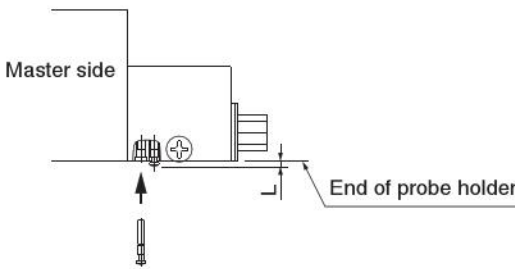

Electrical interface (non-contact terminals)

● Non-contact terminals

<System configuration>

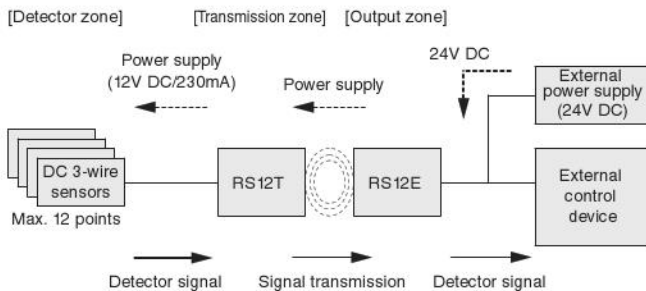

[Role of each component]

- Detector:** Connect a commercially available detector switch to send "Detected signals" to the "Transmitter".
- Transmitter:** Supplies power to the "Detector" and does non-contact transmission of detected signals from the "Detector" to the "Output component".
- Output component:** Outputs detected signals transmitted by the "Transmitter" and supplies the electric power needed to operate the "Detector" and "Transmitter".

■ Master side specifications

Model	EMJE-RM
Power supply voltage	24 VDC ±10% (including ripple)
Consumption current	≤600mA
Output signal points	12 points + 1 point (status)
Load current	≤50mA/1 output
LED indicator	Status (green), output (orange)
Circuit protection	Short protection, reverse contact protection, surge protection
Operating ambient temperature	0 to 50 °C [32 to 122 °F]
Protective structure	IP67 ^{Note 1}
Connecting cable	PURφ 8.6 [0.339]×2 m [6.560 ft] 2×0.5 mm ² [0.001 in ²]+13×0.18 mm ² [0.0002 in ²]
Material	ABS

* Uses RS12E-422N-PU-02 manufactured by B & Plus.

■ Tool side specifications

Model	EMJE-RT
Supported sensors	DC 3-wire sensors
Drive voltage	12V ± 1.5V DC
Drive current	≤230mA ^{Note 2}
Input signal points	12 points
Transmission distance	2 to 5 mm [0.079 to 0.197 in.]
Allowable axial misalignment	±3 mm [0.118 in.]
Operating ambient temperature	0 to 50 °C [32 to 122 °F]
Protective structure	IP67 ^{Note 1}
Connecting cable	PURφ 8.6 [0.339]×1 m [3.280 ft] 2×0.5 mm ² [0.001 in ²]+13×0.18 mm ² [0.0002 in ²]
Material	ABS

* Uses RS12T-422-PU-01 manufactured by B & Plus.

Note 1: Compatible for non-contact terminals, not including electric auto hand changer itself.

Note 2: Use within a range that the total consumed current of the connected detection sensors and drive units does not exceed the drive current value.

<Usable sensors>

Power supply voltage	12V DC
Total consumed current	≤230mA
Residual voltage	≤3.5V
Load current	-

<Wiring diagram>

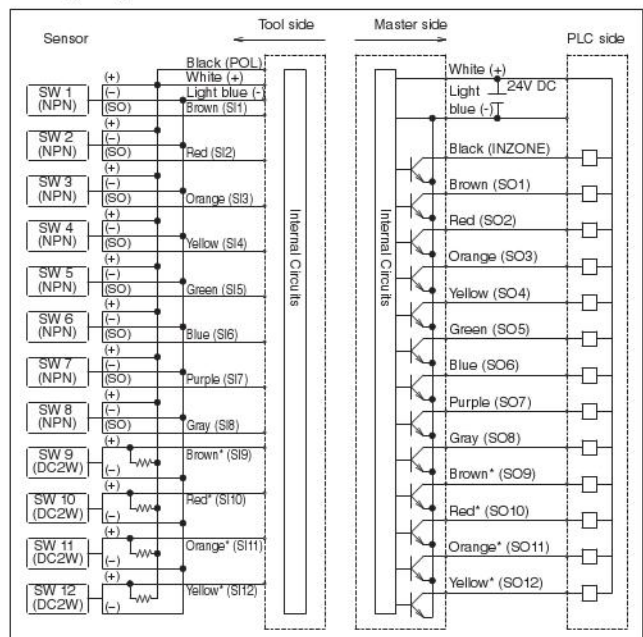

■ SW9 to 12 in the above diagram are examples using DC 2-wire wiring (use wiring for resistance of about 1 to 2 KΩ). DC 3-wire sensors can also be used.

■ Green*, blue*, and purple* cables are not used.

Handling Instructions and Precautions

<Installation conditions>

- When installing the product, be sure to leave at least as much open space around it, as shown in the diagram, to avoid the effects of surrounding metal objects and interference with the product.

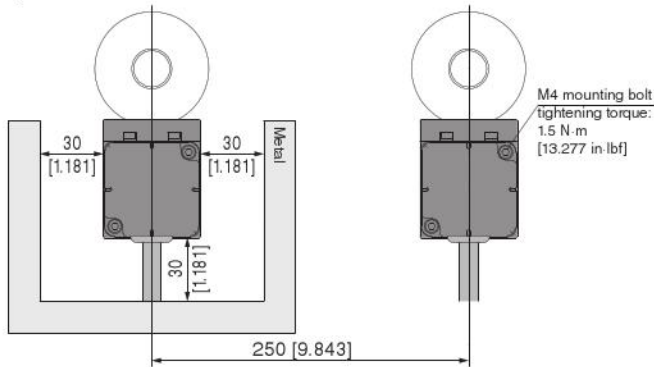

- Note 1: The cables have a bending radius of 50 [1.969 in.] mm or more. Also, do not pull too strongly on the cables.
 2: If the length of cable being used exceeds 10 m [32.800 ft], implement measures so extreme surges do not occur.

⚠ WARNING

- If the power is turned on while metal dust or chips are stuck to the transmission surface, the transmitter and the metal dust and chips stuck to it will heat up, which may lead to an unexpected accident. Be sure to remove any metal dust or chips stuck to the transmission surface before operating the system.
- To prevent malfunctions caused by induction noise, etc., run the cables so the power wires are separated from any high-voltage devices.
- Install equipment so the ends of cables (wiring parts) are not splashed with water or cutting fluid. (Water may pass through the core of cables to the main unit and cause problems, such as short circuits or corrosion)
- Start up make take some time because once the power terminals on the master side and the tool side are facing, the facing parts are confirmed by in-zone signals, and then the designated power is supplied. The start up time is ≤ 0.2 seconds.
- Do not touch the hot parts (power terminals) during operation or immediately after operation. Doing so could result in burns.

<Description of LED indicators>

■ Status LED (green)

State of LED	Flashing cycle	Pattern	Description
Lit	●	-	Power is being supplied correctly.
Off	●	-	Power is not being supplied.
Flashing	⚡ Slow (1.5 sec)	Long off	When temperature is abnormal.
Flashing	⚡ (1.5 sec)	Long on	Over-current on oscillator circuit.
Flashing	⚡ Medium speed (0.6 sec)	Long off	Voltage is high.
Flashing	⚡ (0.6 sec)	Long on	Voltage is low.
Flashing	⚡ High speed (0.2 sec)	Equal interval Flashing	Short protection has activated.

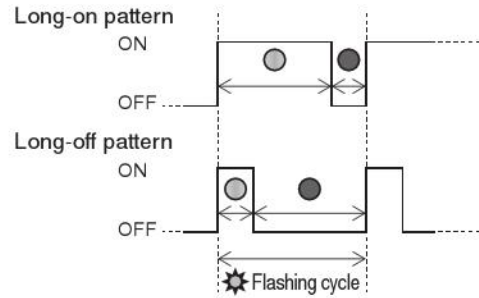

■ Signal LED (orange)

The in-zone LEDs are opposite each other on the master side and the tool side, when transmission is possible, they light. Also, they flash when signals are output from the various sensors.

The information on the page is excerpted from the remote system users guide from B & Plus. For details, refer to the "Remote System Users Guide" and "Safety Precautions" provided with the non-contact terminals from B and Plus, for their correct usage.

Tightening torque

● Installing the main unit

Model	Screw size	Tightening torque (N·m [in·lbf])
EMJ3M EMJ3T	M5	3 [26.553]
EMJ10M EMJ10T	M5	3 [26.553]
EMJ30M EMJ30T	M8	12.5 [110.6]

● Installing the electrical interface

Type	Model	Electrical interface		Cover		Adapter	
		Screw size	Tightening torque (N·m [in·lbf])	Screw size	Tightening torque (N·m [in·lbf])	Screw size	Tightening torque (N·m [in·lbf])
Solder terminals	EMJE-PM(-3,-30)	M3	0.32 [2.832]	M2	0.09 [0.797]	M3 ^{Note 1}	0.63 [5.576] ^{Note 1}
	EMJE-PT(-3,-30)					M4 ^{Note 2}	1.5 [13.277] ^{Note 2}
Solder terminals With cable	EMJE-PAM(-3,-30)	M3	0.32 [2.832]	M2	0.09 [0.797]	M3 ^{Note 1}	0.63 [5.576] ^{Note 1}
	EMJE-PBM(-3,-30)					M4 ^{Note 2}	1.5 [13.277] ^{Note 2}
	EMJE-PAT(-3,-30)					M4 ^{Note 2}	1.5 [13.277] ^{Note 2}
Mini-connectors	EMJE-CM(-3,-30)	M3	0.32 [2.832]	-	-	M3 ^{Note 1}	0.63 [5.576] ^{Note 1}
	EMJE-CT(-3,-30)					M4 ^{Note 2}	1.5 [13.277] ^{Note 2}
D-sub connector	EMJE-DM(-3,-30)	M3	0.32	-	-	M3 ^{Note 1}	0.63 [5.576] ^{Note 1}
	EMJE-DT(-3,-30)		2 [2.832]			M4 ^{Note 2}	1.5 [13.277] ^{Note 2}
Non-contact terminals	EMJE-RM(-3,-30)	M4	1	-	-	M3 ^{Note 1}	0.63 [5.576] ^{Note 1}
	EMJE-RT(-3,-30)		5 [13.277]			M4 ^{Note 2}	1.5 [13.277] ^{Note 2}

- Note 1: When -3 is selected
 2: When -30 is selected

Model selection method

When selecting a model size, consider the eccentricity distance and bending moment, including the payload, so that it stays within the range of the shaded area shown below.

Allowable eccentricity distance and bending moment are confirmed in steps ① to ④.

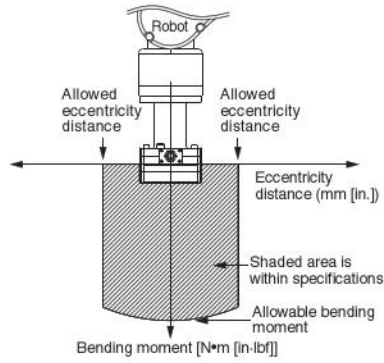

Step ① Select the size model in which the tool load $W1$ and the eccentricity distance $L1$ when lifting satisfy the allowable eccentricity distance $A1$ in graph 1.

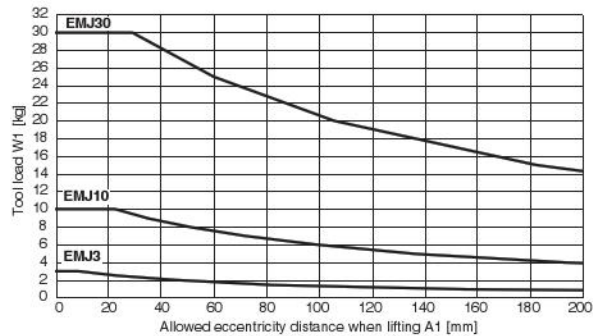
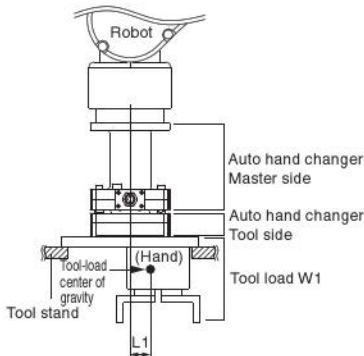

Graph 1) Allowed eccentricity distance when lifting

Step ② Select the size model in which the handling load $W2$ and eccentricity distance $L2$ after lifting satisfy the allowable eccentricity distance $A2$ in graph 2 during acceleration/deceleration α .

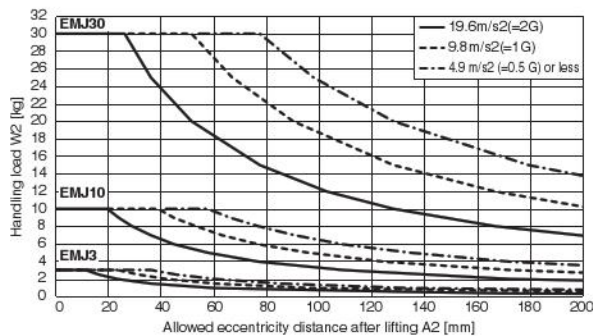
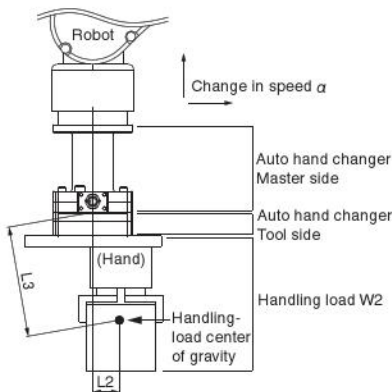

Graph 2) Allowed eccentricity distance after lifting

- Step ③ Generate handling load $W2$, center of gravity distance $L3$, and acceleration/deceleration α .
Select the size model in which the bending moment M is within the allowable bending moment.
- Step ④ Select a size model so the generated torsional moment T is within the allowable torsional moment.

	EMJ3	EMJ10	EMJ30
Allowable bending moment [N·m [in·lbf]]	5 [44.255]	30 [265.5]	75 [663.8]
Allowable torsional moment [N·m [in·lbf]]	10 [88.510]	45 [398.3]	100 [885.1]

● Example of selection

<Assumed operating conditions>

$L1=20$ mm [0.787 in.], $L2=50$ mm [1.969 in.], $L3=200$ mm [7.874 in.], $W1=2$ kg [4.410 lb], $W2=3$ kg [6.615 lb], acceleration/deceleration $\alpha=9.8$ m/s² (=1G)

Step ① From $W1=2$ kg [4.410 lb] and $L1=20$ mm [0.787 in.], EMJ3 satisfies the conditions in graph 1

→EMJ3 is a candidate

Step ② From $W2=3$ kg [6.615 lb], $L2=50$ mm [1.969 in.], and $\alpha=9.8$ m/s² [1 G], EMJ10 satisfies the conditions in graph 2

→EMJ10 is a candidate

Step ③ · For a SCARA robot

$M=W2 \times \alpha \times L3 \times 10^{-3} = 3$ kg [6.615 lb] $\times 9.8$ m/s² [1 G] $\times 200$ mm [7.874 in.] $\times 10^{-3} = 5.88$ N·m [52.044 in·lbf] ≤ 30 N·m [265.5 in·lbf]

(allowable bending moment of EMJ10)

→EMJ10 is a candidate

· For a vertical articulated robot

$M=W2 \times (\alpha + g) \times L3 \times 10^{-3} = 3$ kg [6.615 lb] $\times (9.8$ m/s² [1 G] $+ 9.8$ m/s² [1 G]) $\times 200$ mm [7.874 in.] $\times 10^{-3} = 11.76$ N·m [104.1 in·lbf] ≤ 30 N·m [265.5 in·lbf]

(allowable bending moment of EMJ10)

→EMJ10 is a candidate

Step ④ $T=W2 \times \alpha \times L2 \times 10^{-3} = 3$ kg [6.615 lb] $\times 9.8$ m/s² [1 G] $\times 50$ mm [1.969 in.] $\times 10^{-3} = 1.47$ N·m [13.011 in·lbf] ≤ 45 N·m [398.3 in·lbf]

(allowable torsional moment of EMJ10)

→EMJ10 is a candidate

Selection result → Select EMJ10

Electric auto hand changer



Specifications

● Main unit specifications

Item	Basic type	Master side	EMJ3M	EMJ10M	EMJ30M
		Tool side	EMJ3T	EMJ10T	EMJ30T
Motor			Brush DC motor		
Maximum payload capacity	kg [lb]		3 [6.615]	10 [22.050]	30 [66.150]
Mated axial force ^{Note 2}	N [lbf]		500 [112.4]	1300 [292.2]	3200 [719.4]
Mass	Master side	g [oz]	300 [10.58]	650 [22.93]	1400 [49.38]
	Tool side	g [oz]	130 [4.59]	200 [7.05]	600 [21.16]
	Both sides	g [oz]	430 [15.17]	850 [29.98]	2000 [70.55]
Allowable bending moment	N·m [in·lbf]		5 [44.255]	30 [265.5]	75 [663.8]
Allowable torsional moment	N·m [in·lbf]		15 [132.8]	45 [398.3]	100 [885.1]
Operating temperature range	°C [°F]		0 to 60 [32 to 140] ^{Note 1}		
Operating humidity range	%RH		20 to 80% RH (no condensation)		
Lubrication			Not required		
Positional repeatability	mm [in.]		±0.003 [0.0001]		
Angle repeatability	deg		±0.05		
Mounting/unmounting time	s		2.5 or less		
Electrical interface	Solder terminals		○	○	○
	Solder terminals with cables		○	○	○
	Mini-connectors		○	○	○
	D-sub connector		○	○	○
	Non-contact terminals		○	○	○

Note 1: When using non-contact terminals, 0 to 50 °C [32 to 122 °F]

2: Force to maintain mated state

Specifications

● Electrical interface specifications

Item	Basic type		EMJE-PM	EMJE-PAM	EMJE-PBM	EMJE-CM
	Master side	Tool side	EMJE-PT	EMJE-PAT	-	EMJE-CT
Wiring type			Solder terminals	Solder terminals with 1-m [3.280 ft] cables	Solder terminals with 3-m [9.840 ft] cables	Mini-connectors
Number of connectors	pc		15	15	15	9
Rated current	A		3	2.3	2.3	1
Mass	Master side	Terminal g [oz]	11 [0.39]	11 [0.39]	11 [0.39]	9 [0.32]
		(Adapter additional mass) g [oz]	When -3 is selected: +6 [0.21]	When -3 is selected: +6 [0.21]	When -3 is selected: +6 [0.21]	When -3 is selected: +6 [0.21]
		(Adapter additional mass) g [oz]	When -30 is selected: +20 [0.71]	When -30 is selected: +20 [0.71]	When -30 is selected: +20 [0.71]	When -30 is selected: +20 [0.71]
		Cable g [oz]	-	+150 [5.29]	+450 [15.87]	-
	Tool side	Terminal g [oz]	7 [0.25]	7 [0.25]	-	8 [0.28]
		(Adapter additional mass) g [oz]	When -3 is selected: +6 [0.21]	When -3 is selected: +6 [0.21]	-	When -3 is selected: +6 [0.21]
		(Adapter additional mass) g [oz]	When -30 is selected: +20 [0.71]	When -30 is selected: +20 [0.71]	-	When -30 is selected: +20 [0.71]
		Cable g [oz]	-	+150 [5.29]	-	-

Item	Basic type		EMJE-DM	EMJE-RM	EMJE-CAM	EMJE-CBM
	Master side	Tool side	EMJE-DT	EMJE-RT	EMJE-CAT	-
Wiring type			D-sub connector	Non-contact terminals	1-m [3.280 ft] cable for mini-connectors	3-m [9.840 ft] cable for mini-connectors
Number of connectors	pc		15	12	9	9
Rated current	A		3	0.05 ^{Note}	1	1
Mass	Master side	Terminal g [oz]	29 [1.02]	80 [2.82]	5 [0.18]	5 [0.18]
		(Adapter additional mass) g [oz]	When -3 is selected: +10 [0.35]	When -3 is selected: +60 [2.12]	-	-
		(Adapter additional mass) g [oz]	When -30 is selected: +20 [0.71]	When -30 is selected: +60 [2.12]	-	-
		Cable g [oz]	-	+210 [7.41]	+50 [1.76]	+150 [5.29]
	Tool side	Terminal g [oz]	22 [0.78]	75 [2.65]	5 [0.18]	-
		(Adapter additional mass) g [oz]	When -3 is selected: +10 [0.35]	When -3 is selected: +60 [2.12]	-	-
		(Adapter additional mass) g [oz]	When -30 is selected: +20 [0.71]	When -30 is selected: +60 [2.12]	-	-
		Cable g [oz]	-	+105 [3.70]	+50 [1.76]	-

Note: To confirm the specifications for current values, see the non-contact terminals specifications below.

● Non-contact terminals specifications (excerpt)

■ Master side specifications

Model	EMJE-RM
Power supply voltage	24 VDC ±10% (including ripple)
Consumption current	≤600mA
Output signal points	12 points + 1 point (status)
Load current	≤50mA/1 output
LED indicator	Status (green), output (orange)
Circuit protection	Short protection, reverse contact protection, surge protection
Operating ambient temperature	0 to 50 °C [32 to 122 °F]
Protective structure	IP67 ^{Note 1}
Connecting cable	PURφ 8.6 [0.339]×2 m [6.560 ft] 2×0.5 mm ² [0.0008 in ²]+13×0.18 mm ² [0.0003 in ²]
Material	ABS

* Manufactured by B and Plus
Uses RS12E-422N-PU-02.

■ Tool side specifications

Model	EMJE-RT
Supported sensors	DC 3-wire sensors
Drive voltage	12V ± 1.5V DC
Drive current	≤230mA ^{Note2}
Input signal points	12 points
Transmission distance	2 to 5 mm [0.197 in.]
Allowable axial misalignment	±3 mm [0.118 in.]
Operating ambient temperature	0 to 50 °C [32 to 122 °F]
Protective structure	IP67 ^{Note 1}
Connecting cable	PURφ 8.6 [0.339]×1 m [3.280 ft] 2×0.5 mm ² [0.0008 in ²]+13×0.18 mm ² [0.0003 in ²]
Material	ABS

* Manufactured by B and Plus
Uses RS12T-422-PU-01.

<Usable sensors>

Power supply voltage	12V DC
Total consumed current	≤230mA
Residual voltage	≤3.5V
Load current	-

Note 1: Compatible for non-contact terminals, not including electric auto hand changer itself.

Note 2: Use within a range that the total consumed current of the connected detection sensors and drive units does not exceed the drive current value.

* See page ⑩ for details of the specifications.

Order Codes

Main unit models

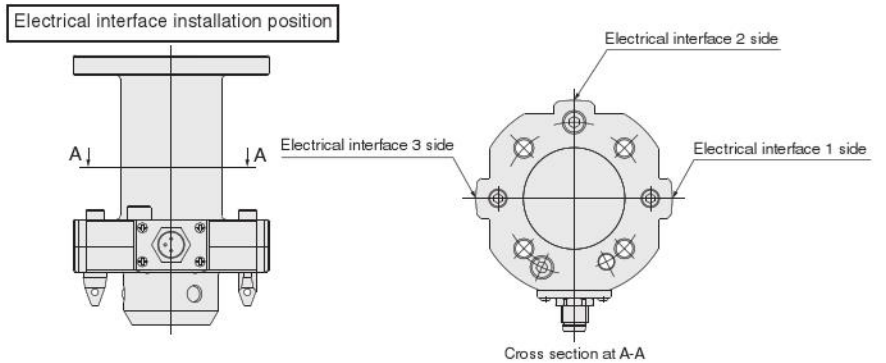
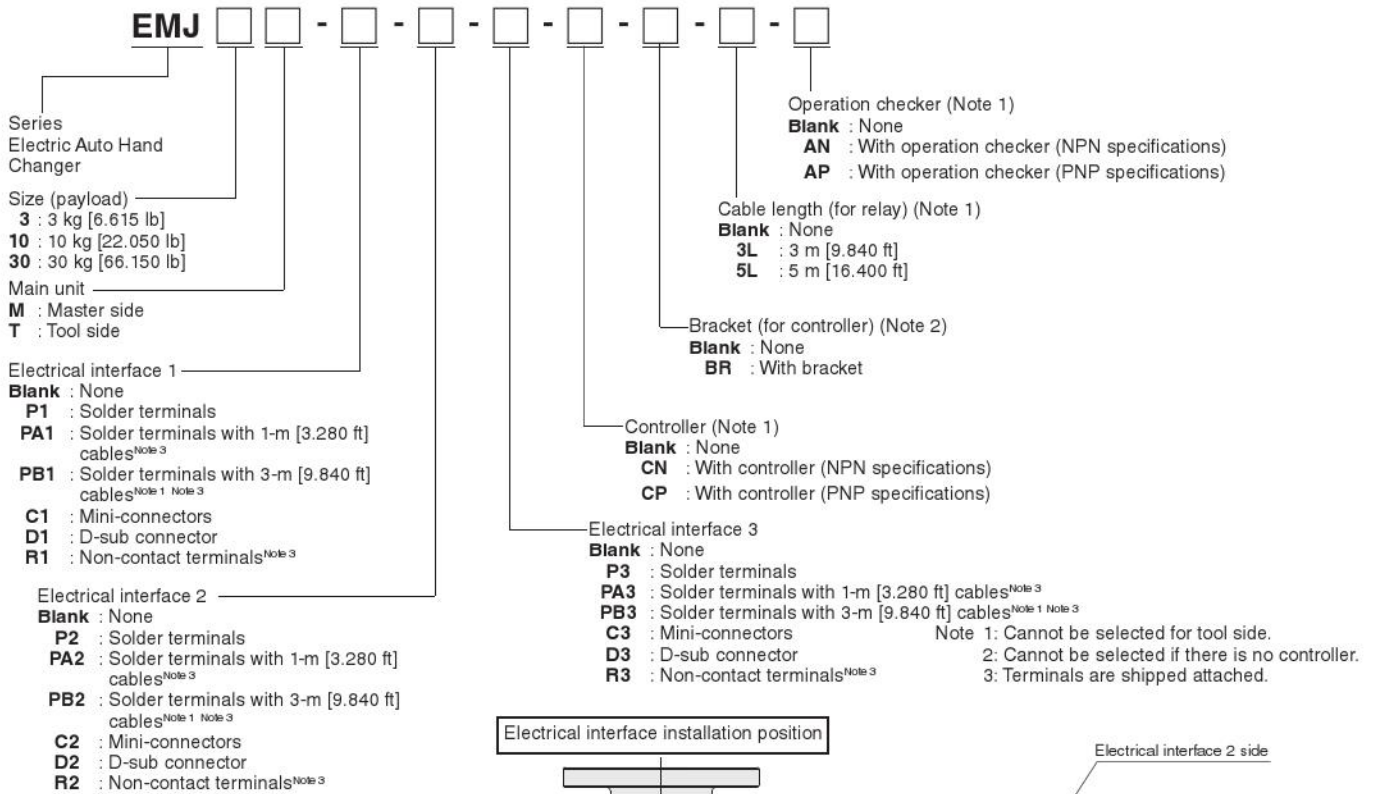

Additional Parts

Electrical Interface

Solder terminals

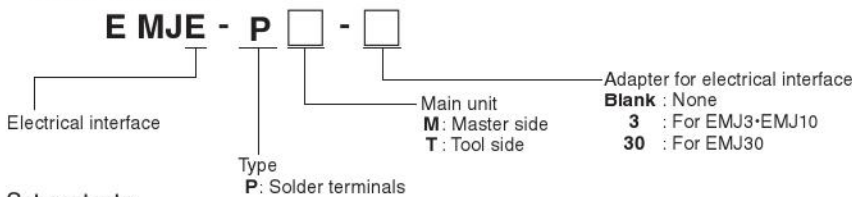

Set contents

Model	Part name	Material	Count
EMJE-PM EMJE-PT	Terminal(*)	-	1
	Hexagon socket head bolt M3 x 0.5, length under head 16	Stainless steel	2
EMJE-PM-3 EMJE-PT-3	Terminal(*)	-	1
	Hexagon socket head bolt M3 x 0.5, length under head 16	Stainless steel	2
	Adapter	Aluminum alloy (electroless nickel plated)	1
	Hexagon socket head bolt M3 x 0.5, length under head 8	Stainless steel	2
EMJE-PM-30 EMJE-PT-30	Parallel pin JIS B 1354 B type 2x4	Stainless steel	2
	Terminal(*)	-	1
	Hexagon socket head bolt M3 x 0.5, length under head 16	Stainless steel	2
	Adapter	Aluminum alloy (electroless nickel plated)	1
	Hexagon socket head bolt M4 x 0.7, length under head 10	Stainless steel	2
	Parallel pin JIS B 1354 B type 4x8	Stainless steel	2

Note: The * mark indicates parts with different shapes for the master side and the tool side.

Additional Parts

• Solder terminals with cables

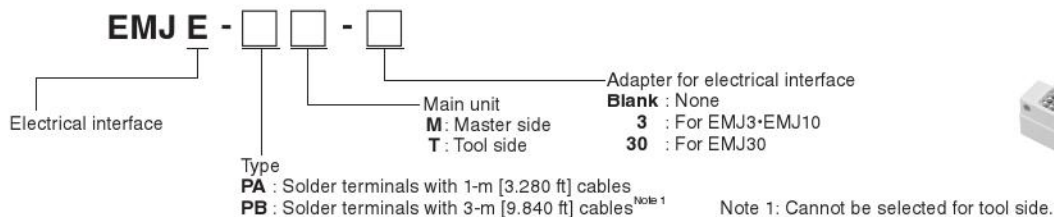

Set contents

Model	Part name	Material	Count
EMJE-PAM EMJE-PBM EMJE-PAT	Terminal(*)	-	1
	Hexagon socket head bolt M3 x 0.5, length under head 16	Stainless steel	2
EMJE-PAM-3 EMJE-PBM-3 EMJE-PAT-3	Terminal(*)	-	1
	Hexagon socket head bolt M3 x 0.5, length under head 16	Stainless steel	2
	Adapter	Aluminum alloy (electroless nickel plated)	1
	Hexagon socket head bolt M3 x 0.5, length under head 8	Stainless steel	2
EMJE-PAM-30 EMJE-PBM-30 EMJE-PAT-30	Terminal(*)	-	1
	Hexagon socket head bolt M3 x 0.5, length under head 16	Stainless steel	2
	Adapter	Aluminum alloy (electroless nickel plated)	1
	Hexagon socket head bolt M4 x 0.7, length under head 10	Stainless steel	2
	Parallel pin JIS B 1354 B type 4x8	Stainless steel	2

Note: The * mark indicates parts with different shapes for the master side and the tool side.

• Mini-connectors

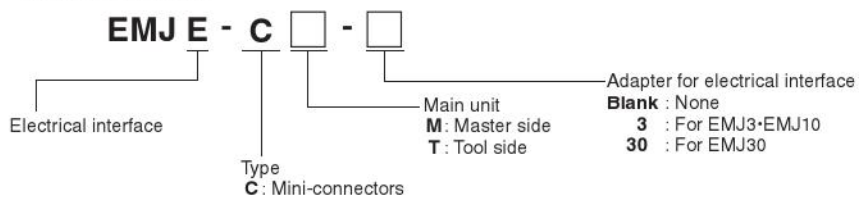

Set contents

Model	Part name	Material	Count
EMJE-CM EMJE-CT	Terminal(*)	-	1
	Hexagon socket head bolt M3 x 0.5, length under head 16	Stainless steel	2
EMJE-CM-3 EMJE-CT-3	Terminal(*)	-	1
	Hexagon socket head bolt M3 x 0.5, length under head 16	Stainless steel	2
	Adapter	Aluminum alloy (electroless nickel plated)	1
	Hexagon socket head bolt M3 x 0.5, length under head 8	Stainless steel	2
EMJE-CM-30 EMJE-CT-30	Terminal(*)	-	1
	Hexagon socket head bolt M3 x 0.5, length under head 16	Stainless steel	2
	Adapter	Aluminum alloy (electroless nickel plated)	1
	Hexagon socket head bolt M4 x 0.7, length under head 10	Stainless steel	2
	Parallel pin JIS B 1354 B type 4x8	Stainless steel	2

Note: The * mark indicates parts with different shapes for the master side and the tool side.

• Cable for mini-connectors

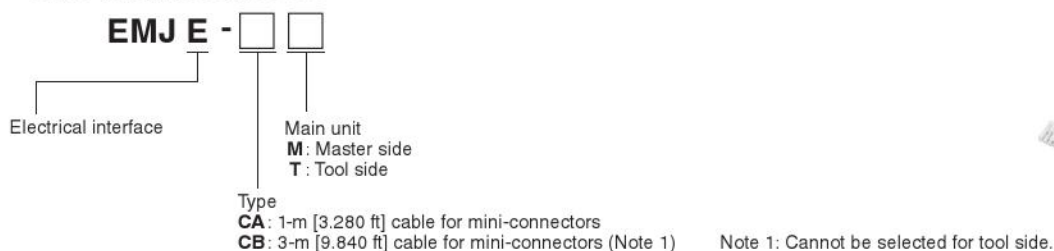

Additional Parts

• D-sub connector

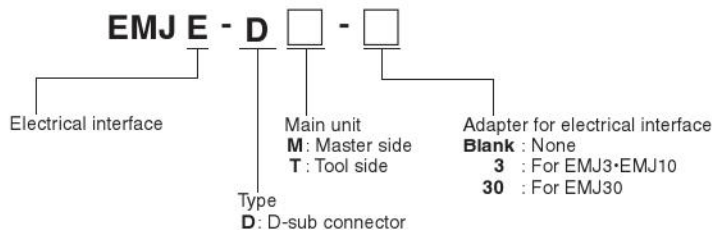

Set contents

Model	Part name	Material	Count
EMJE-DM EMJE-DT	Terminal(*)	-	1
	Specialized bolt (*)	Mild steel (nickel plated)	2
EMJE-DM-3 EMJE-DT-3	Terminal(*)	-	1
	Specialized bolt (*)	Mild steel (nickel plated)	2
	Adapter	Aluminum alloy (anodized)	1
	Hexagon socket head bolt M3 x 0.5, length under head 8	Stainless steel	2
	Parallel pin JIS B 1354 B type 2x4	Stainless steel	2
EMJE-DM-30 EMJE-DT-30	Terminal(*)	-	1
	Specialized bolt (*)	Mild steel (nickel plated)	2
	Adapter	Aluminum alloy (anodized)	1
	Hexagon socket head bolt M4 x 0.7, length under head 10	Stainless steel	2
	Parallel pin JIS B 1354 B type 4x8	Stainless steel	2

Note: The * mark indicates parts with different shapes for the master side and the tool side.

• Non-contact terminals

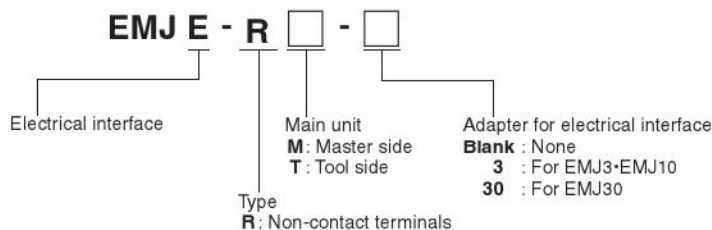

Set contents

Model	Part name	Material	Count
EMJE-RM EMJE-RT	Terminal(*)	ABS	1
	Hexagon socket head bolt M4 x 0.7, length under head 12	Stainless steel	2
EMJE-RM-3 EMJE-RT-3	Terminal(*)	ABS	1
	Hexagon socket head bolt M4 x 0.7, length under head 12	Stainless steel	2
	Adapter	Aluminum alloy (anodized)	1
	Hexagon socket head bolt M3 x 0.5, length under head 8	Stainless steel	2
	Parallel pin JIS B 1354 B type 2x4	Stainless steel	2
EMJE-RM-30 EMJE-RT-30	Terminal(*)	ABS	1
	Hexagon socket head bolt M4 x 0.7, length under head 12	Stainless steel	2
	Adapter	Aluminum alloy (anodized)	1
	Hexagon socket head bolt M4 x 0.7, length under head 10	Stainless steel	2
	Parallel pin JIS B 1354 B type 4x8	Stainless steel	2

Note: The * mark indicates parts with different shapes for the master side and the tool side.
 Manufactured by B and Plus Co., Ltd, RS12E-422N-PU-02 is used on the master side,
 and RS12T-422-PU-01 is used on the tool side.

● Probe terminal for electrical interface

EMJZ - PR



Additional Parts

● Controller

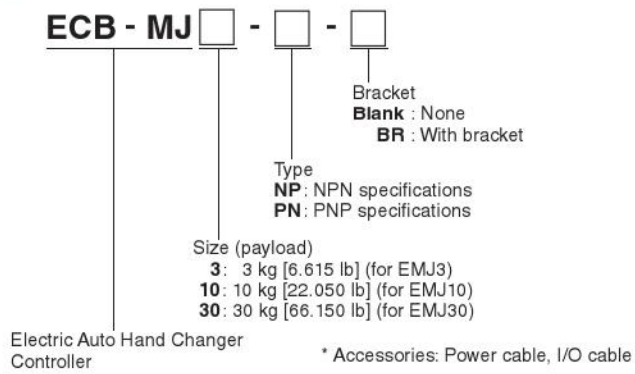

• Bracket for controller (individual part)

PSU - BR



● Operation checker



● Cable

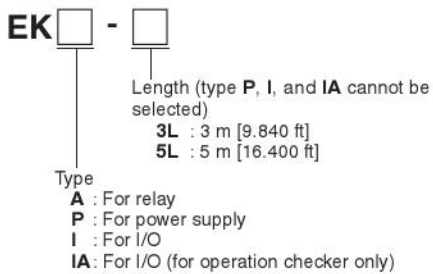

EKA-□: For relay



EKP: For power supply



EKI: For I/O



EKIA: For I/O (for operation checker only)

EMJ3M

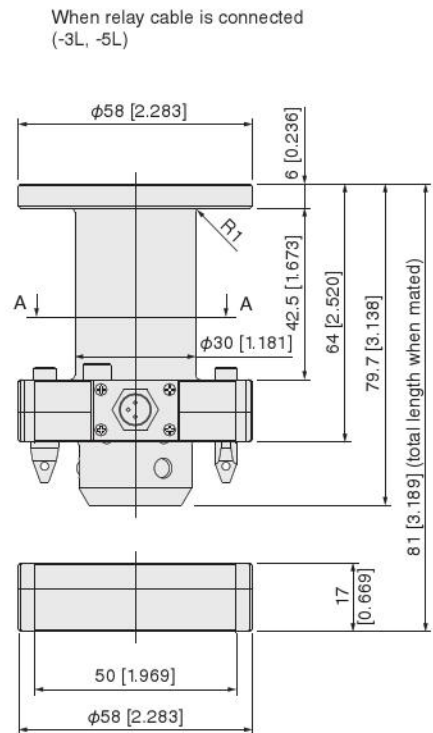
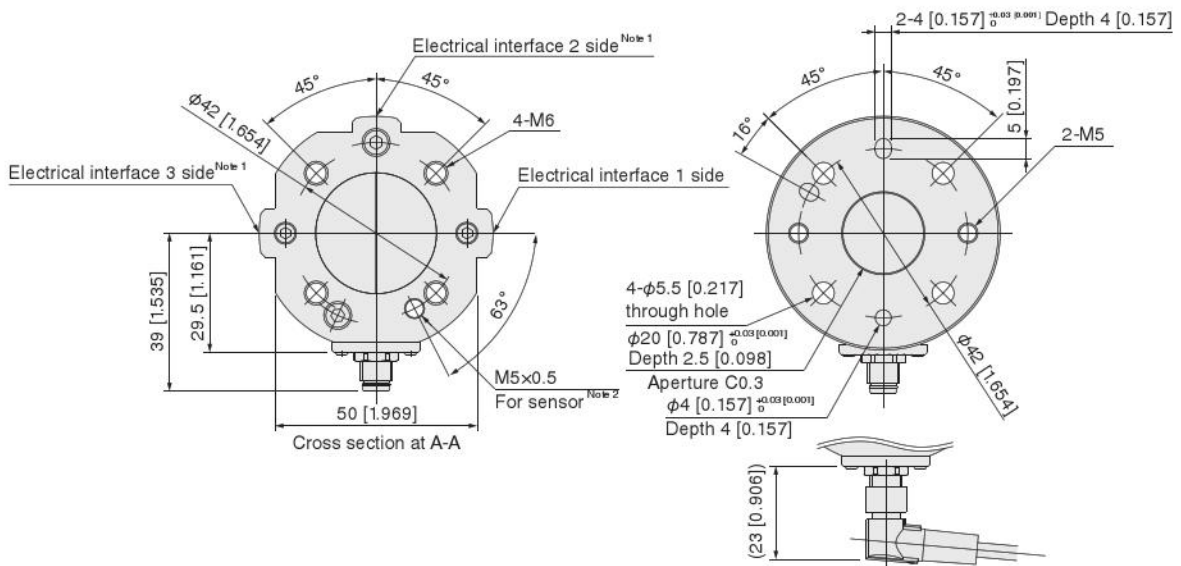

EMJ3T

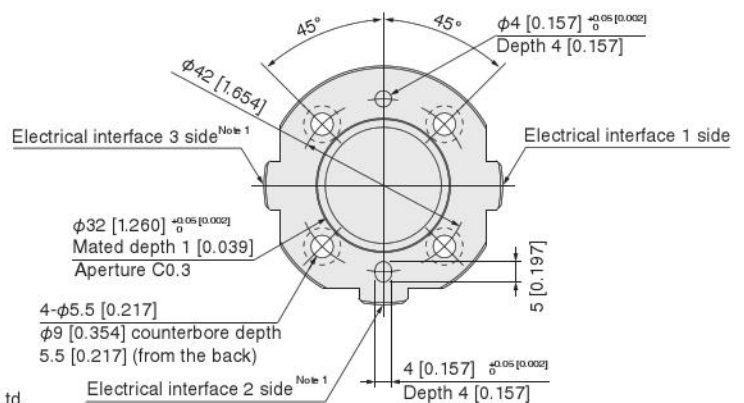

Note 1: For dimensions of the electrical interface 2 side and 3 side, refer to the electrical interface 1 side.
 Note 2: If you intend to use a sensor, please purchase it separately.
 Example: PT5M3CB or CSJ055A, manufactured by Metrol Co., Ltd.

EMJ3

For -P1

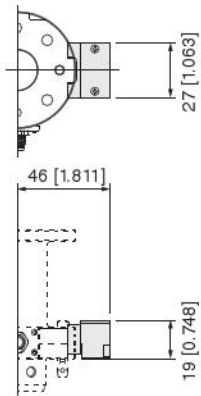

For -PA1, -PB1

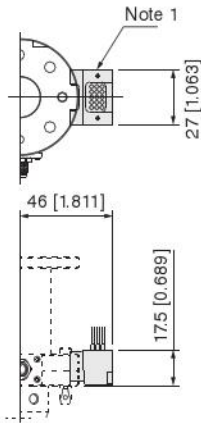

For -C1

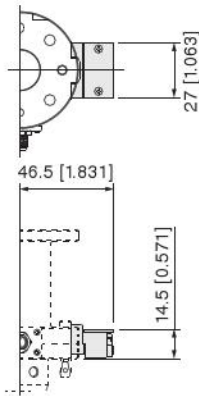

For -D1

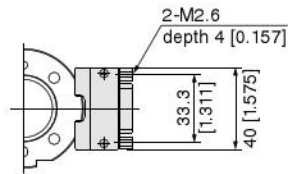
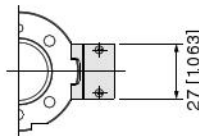
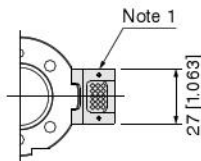
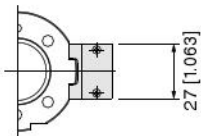
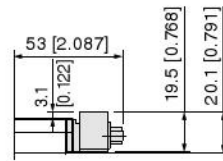
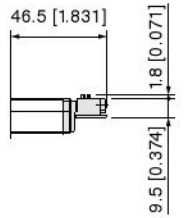
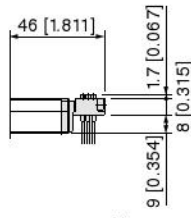
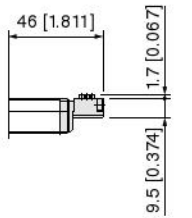
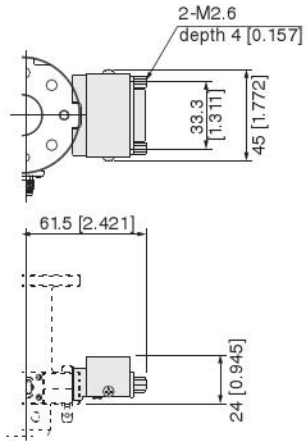

Note 1: For the cables with solder terminals (-PA□, -PB□), only the adapter is shipped assembled, the terminals are shipped attached.

EMJ3

For -R1

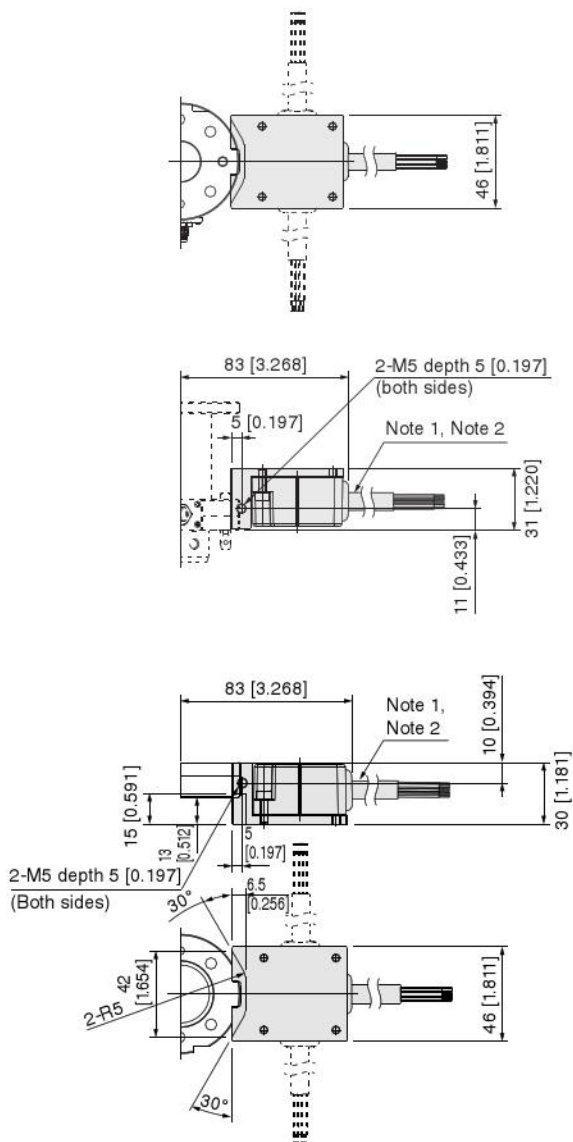

Note 1: For the non-contact terminals (-R□), only the adapters are shipped assembled. Terminals are shipped attached.

2: The non-contact terminals (-R□) can communicate even if the master side and tool side are installed with different orientations.

EMJ10M

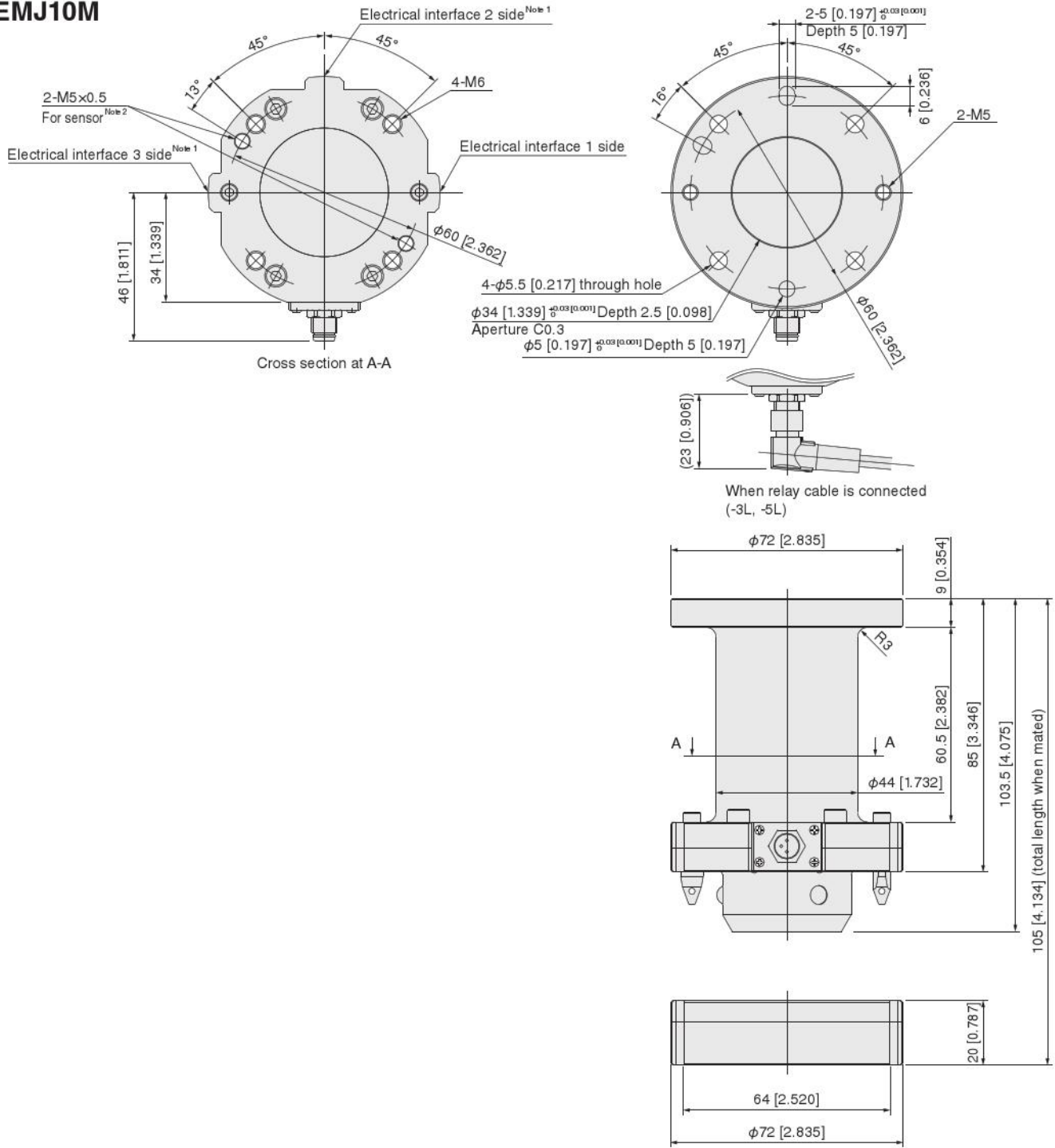

EMJ10T

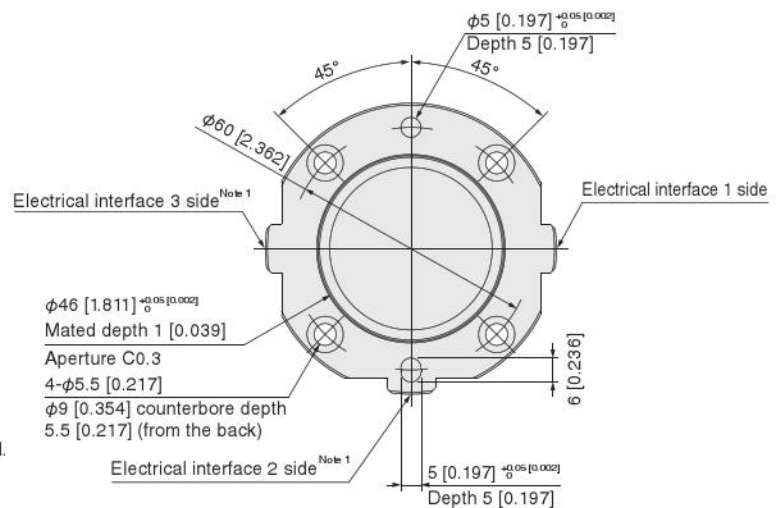

Note 1: For dimensions of the electrical interface 2 side and 3 side, refer to the electrical interface 1 side.
 Note 2: If you intend to use a sensor, please purchase it separately.
 Example: PT5M3CB or CSJ055A, manufactured by Metrol Co., Ltd.

EMJ10

For -P1

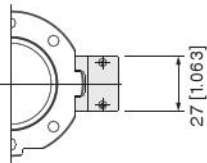
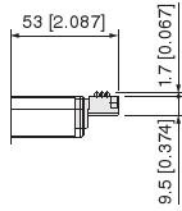
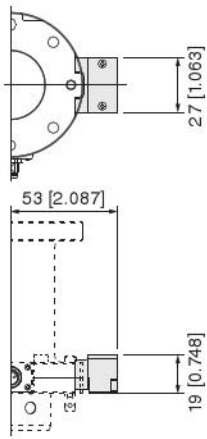

For -PA1, -PB1

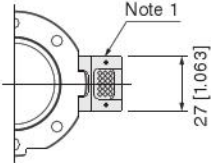
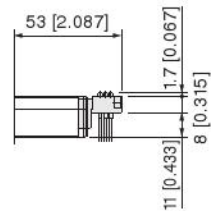
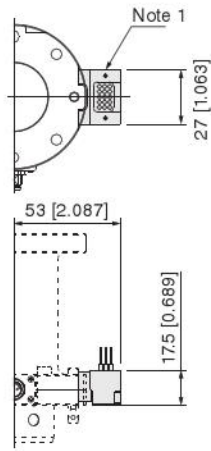

For -C1

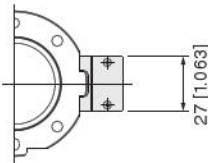
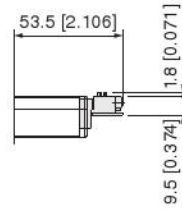
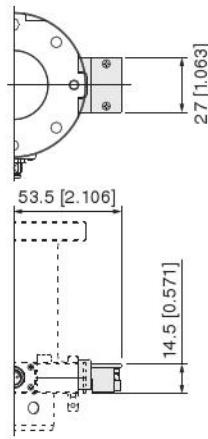

For -D1

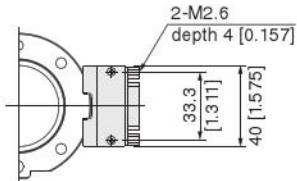
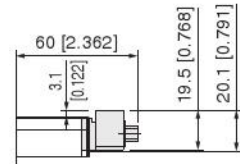
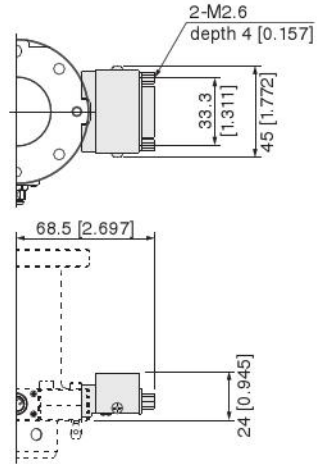

Note 1: For the cables with solder terminals (-PA□, -PB□), only the adapter is shipped assembled, the terminals are shipped attached.

EMJ10

For -R1

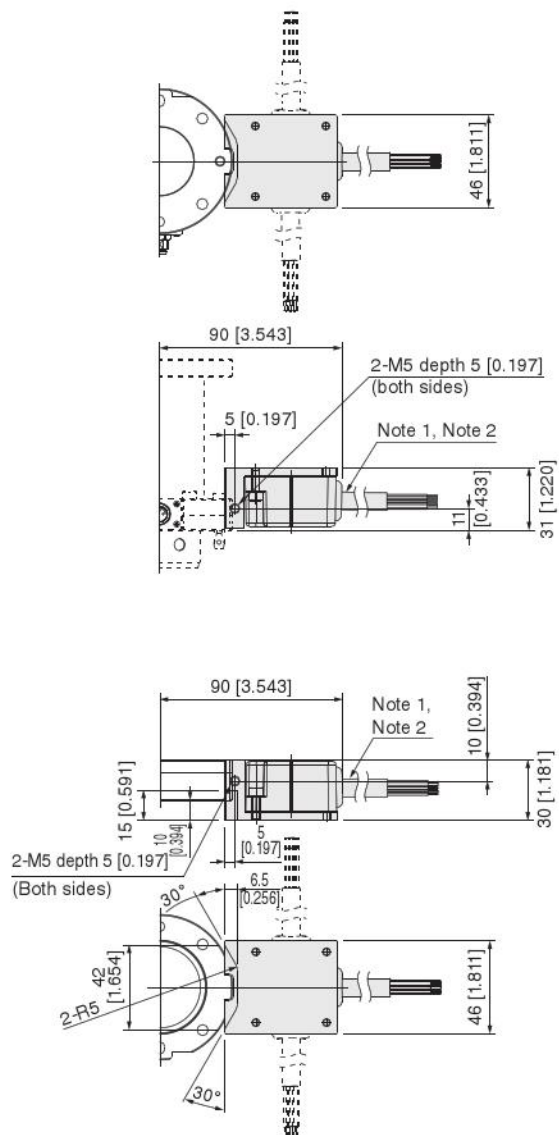

Note 1: For the non-contact terminals (-R□), only the adapters are shipped assembled. Terminals are shipped attached.

2: The non-contact terminals (-R□) can communicate even if the master side and tool side are installed with different orientations.

EMJ30M

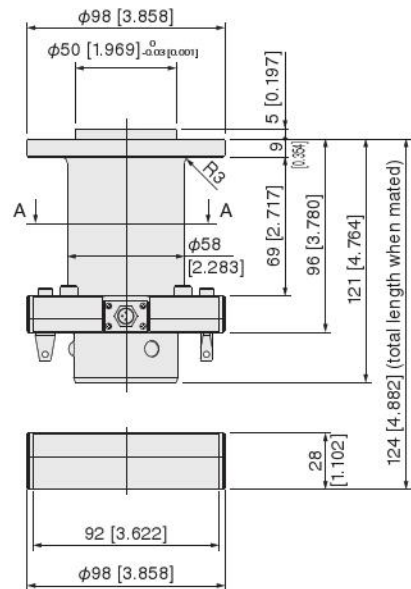
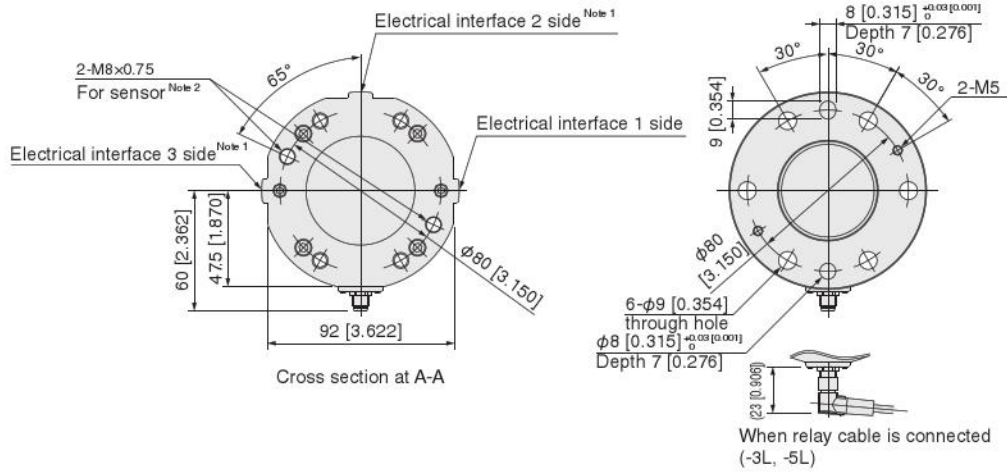

EMJ30T

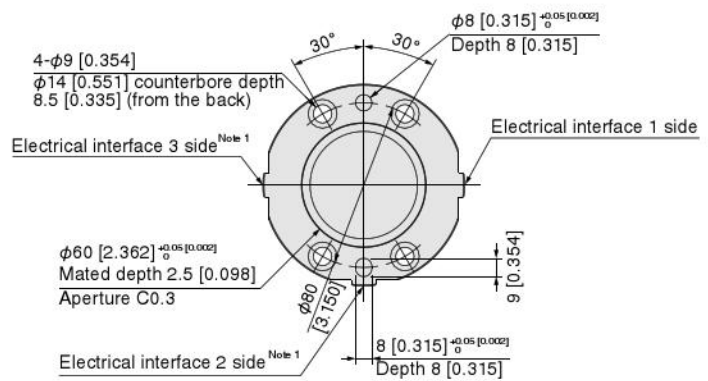

Note 1: For dimensions of the electrical interface 2 side and 3 side, refer to the electrical interface 1 side.

Note 2: If you intend to use a sensor, please purchase it separately.

Example: CS087A, manufactured by Metrol Co., Ltd.

STM8, manufactured by Asa Electronics Industry Co., Ltd.

EMJ30

For -P1

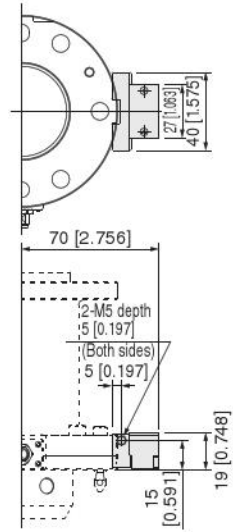

For -PA1, -PB1

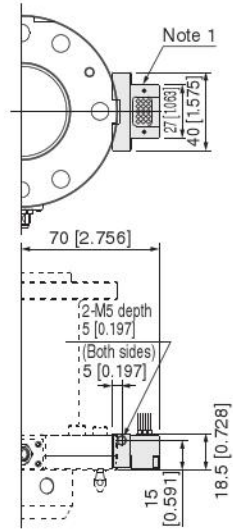

For -C1

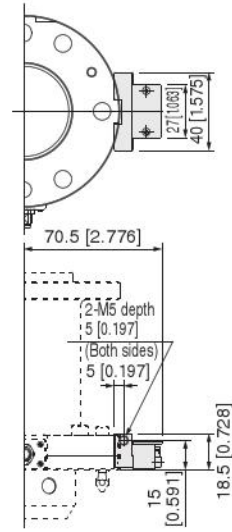

For -D1

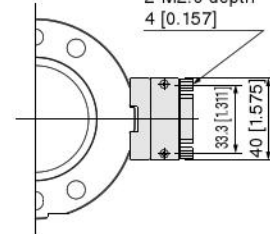
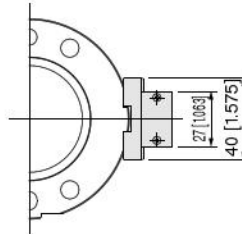
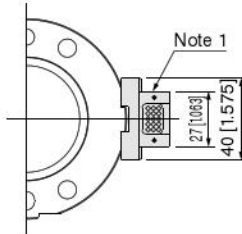
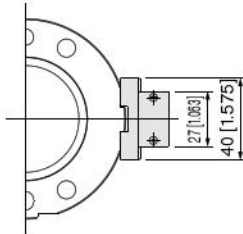
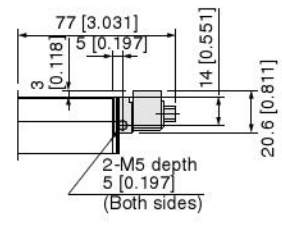
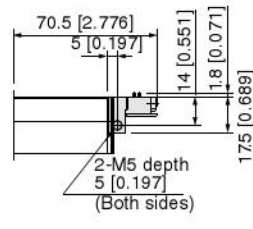
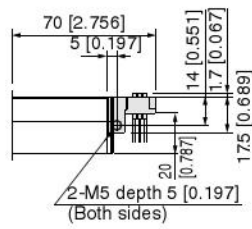
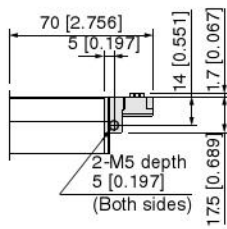
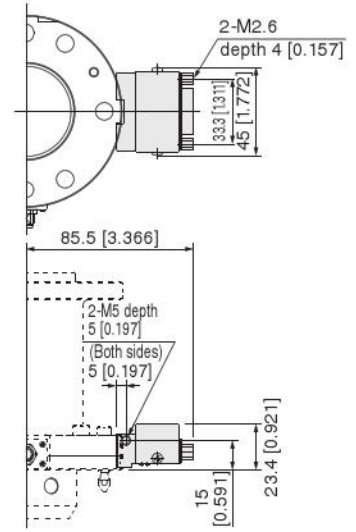

Note1: For the cables with solder terminals (-PA□, -PB□), only the adapter is shipped assembled. Terminals are shipped attached.

EMJ30

For -R1

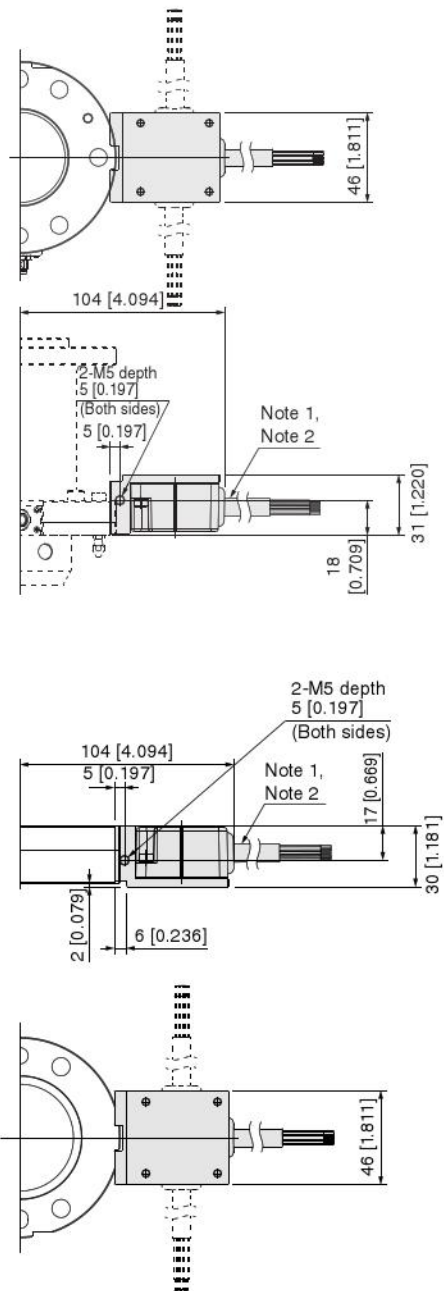

Note 1: For the non-contact terminals (-R), only the adapters are shipped assembled.
Terminals are shipped attached.

2: The non-contact terminals (-R) can communicate even if the master side and tool side are installed with different orientations.

Table of combinations that can be directly installed

- Products that can be directly installed to the electric auto hand changer are available.
Even if direct installation is not possible, they can be installed if the user arranges an adapter, or something.

Table of combinations that can be directly installed on the vacuum pump unit and electric auto hand changer

Vacuum pump unit	
Electric auto hand changer	EVP03MJ
EMJ3 ^{Note 1}	●
EMJ10 ^{Note 2}	●
EMJ30	-

- : Can be directly installed
- : Cannot be directly installed

Note 1: When -R□ (non-contact terminals) is selected, then direct installation is not possible.

2: When -R1, -R3 (non-contact terminals, electric interface 1 side and 3 side), then direct installation is not possible.

Table of combinations that can be directly installed on the flat type electric hand and electric auto hand changer

Flat type electric hand			
Electric auto hand changer	EW2H(L)8	EW2H(L)18	EW2H(L)28
EMJ3	-	●	●
EMJ10	-	-	●
EMJ30	-	-	-

- : Can be directly installed
- : Cannot be directly installed

Controller

NPN specifications



Specifications

Item	Model	ECB-MJ□-NP
Control method	Motor drive method	Square-wave drive
	Control method	Electric current control method
	End detection method	Current detection method
	Number of points	2 points (both ends)
	Control input	2 points (ILK, IULK)
	Control output	3 points (OLK, OULK, ALARM)
	Abnormality detection output	Disconnection, abnormal temperature, abnormal voltage, and idling
	Relay cable	Cable dedicated to motor drive output
	Sensor cable	None
General specifications	Mass	40 g [1.41 oz]
	Power supply	24VDC \pm 10% 1.0A MAX
	Power supply display	+V / 0V / F.G.
	Operating temperature range	0 to 40 °C [32 to 104 °F]
	Operating humidity range	35 to 85% RH (no condensation)
	Storage temperature range	-10 to 65°C [14 to 149°F]
	Conformity rating	CE mark
	Accessories	I/O cable, power cable Mounting bracket (when -BR is selected)

Controller wiring system

1. When using the controller's internal power supply

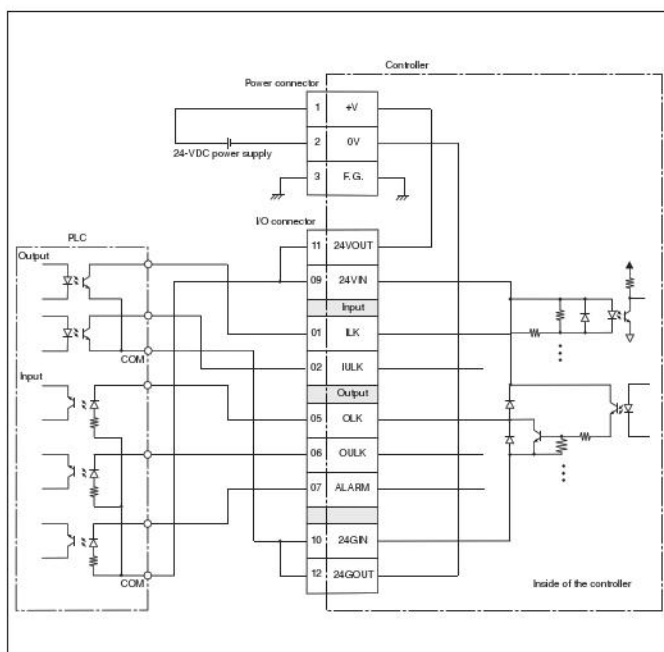

* Even for just input or output, short circuit 09-11 and 10-12.

2. When using a separate power supply, instead of the controller's internal power supply

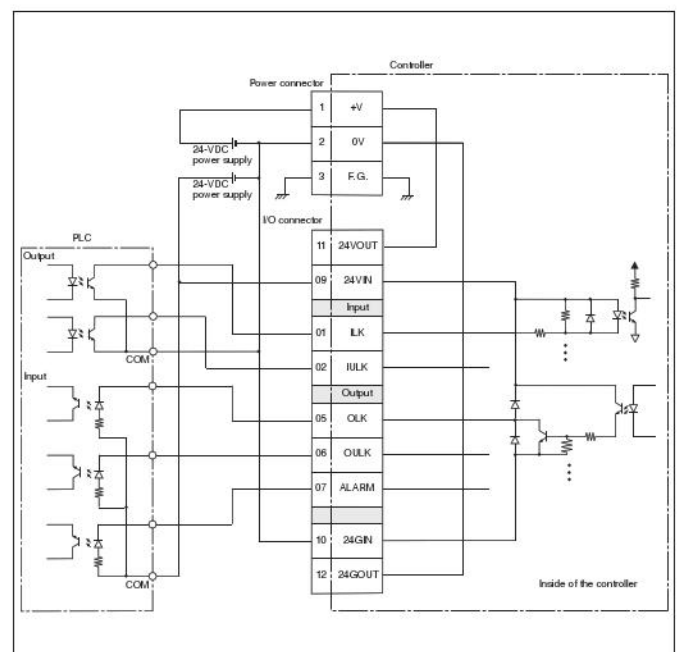

* Even for just input or output, connect the power supply to 09 and 10.

Controller

PNP specifications



Specifications

Item	Model	ECB-MJ□-PN
Control method	Motor drive method	Square-wave drive
	Control method	Electric current control method
	End detection method	Current detection method
	Number of points	2 points (both ends)
	Control input	2 points (ILK, IULK)
	Control output	3 points (OLK, OULK, ALARM)
	Abnormality detection output	Disconnection, abnormal temperature, abnormal voltage, and idling
	Relay cable	Cable dedicated to motor drive output
	Sensor cable	None
General specifications	Mass	40 g [1.41 oz]
	Power supply	DC24V±10% 1.0A MAX
	Power supply display	+V / 0V / F.G.
	Operating temperature range	0 to 40 °C [32 to 104 °F]
	Operating humidity range	35 to 85% RH (no condensation)
	Storage temperature range	-10 to 65°C [14 to 149°F]
	Conformity rating	CE mark
	Accessories	I/O cable, power cable Mounting bracket (when -BR is selected)

Controller wiring system

1. When using the controller's internal power supply

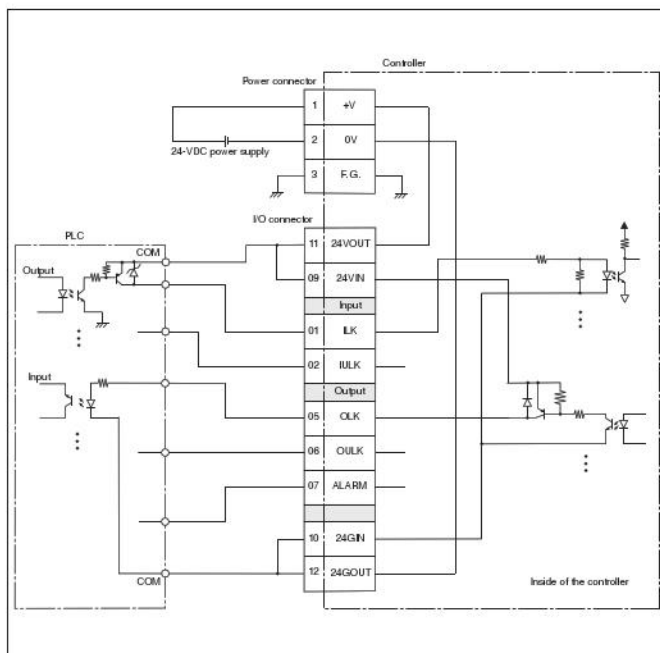

* Even for just input or output, short circuit 09-11 and 10-12.

2. When using a separate power supply, instead of the controller's internal power supply

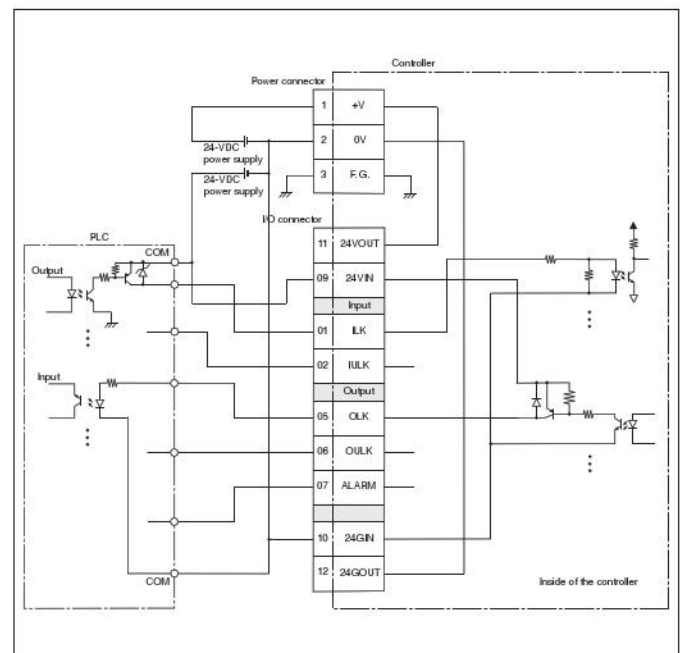

* Even for just input or output, connect the power supply to 09 and 10.

Dimensions (mm [in.])

● Controller

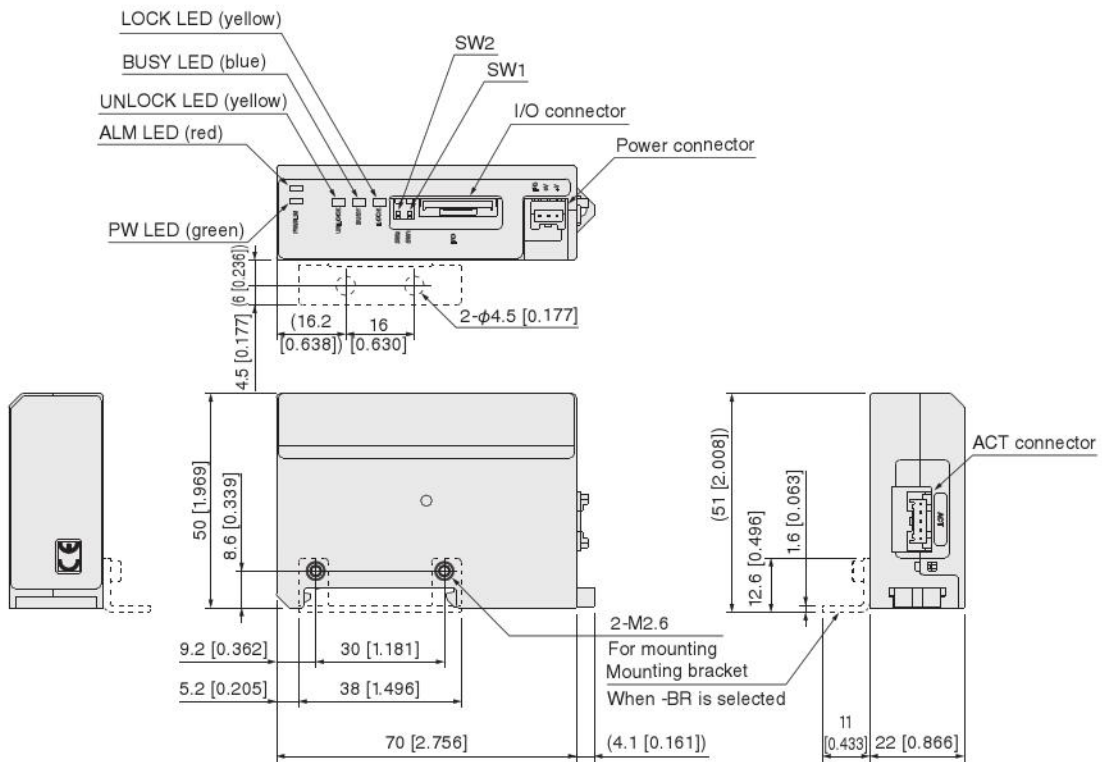
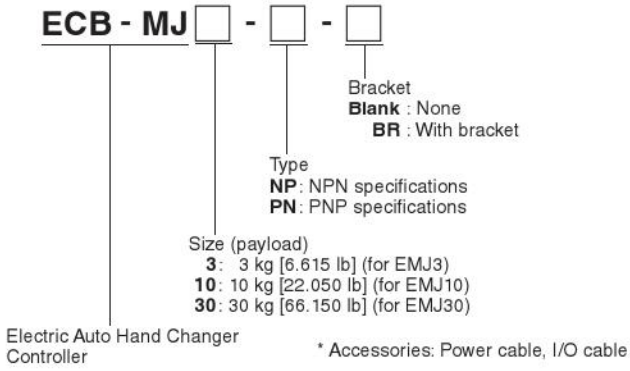

* Dotted lines show bracket dimensions

Dimensions (mm [in.])

● Cable

• For relay

EKA-

3L : 3 m [9.840 ft]
5L : 5 m [16.400 ft]

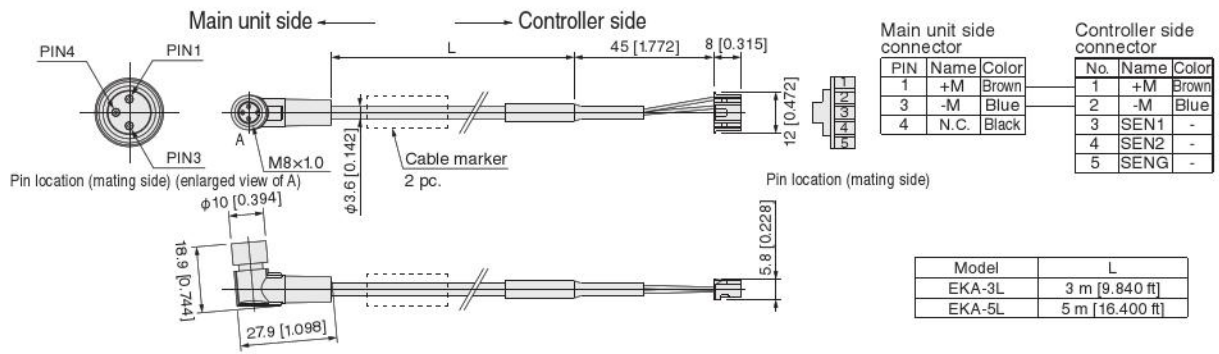

• For power supply

EKP

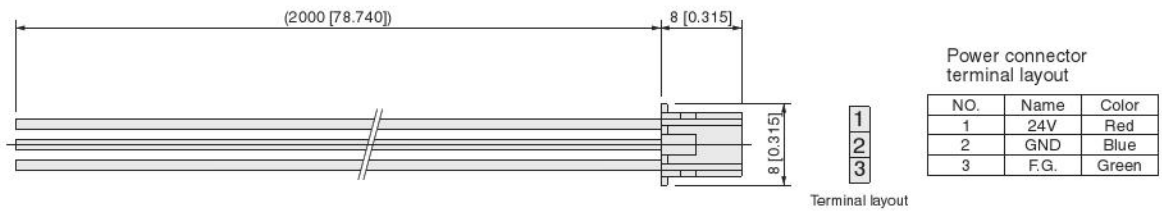

• For I/O

EKI

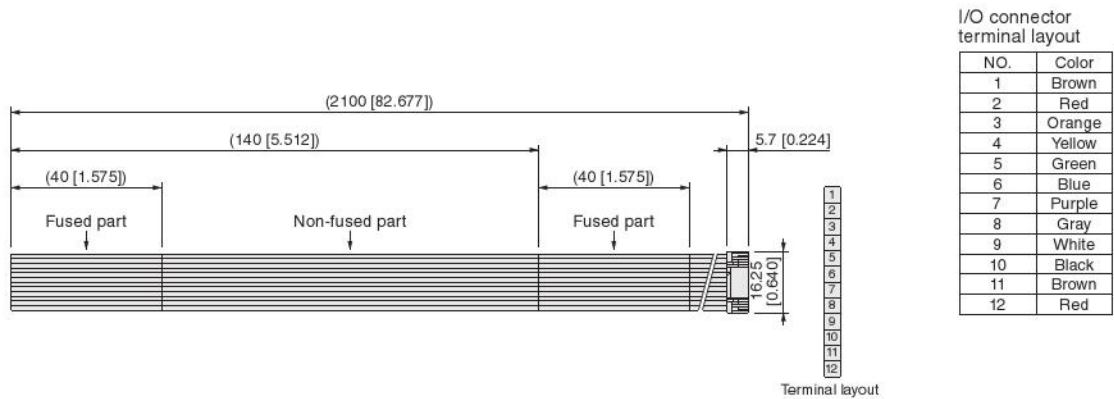

• For I/O (for operation checker only)

EKIA

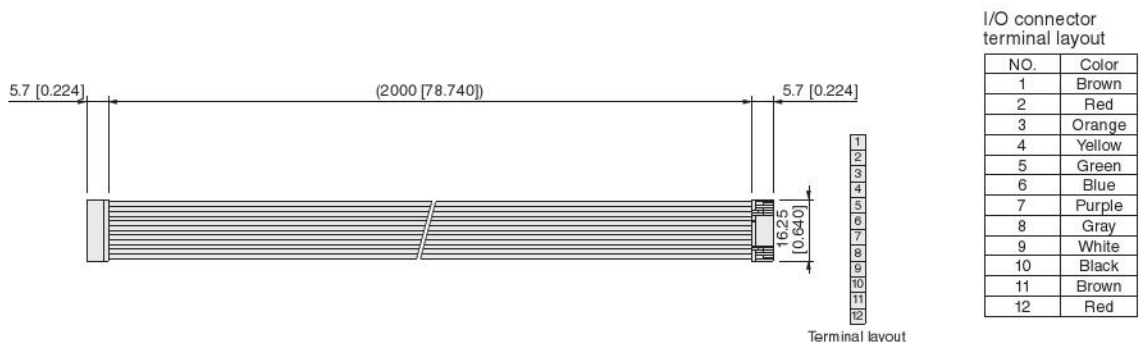

Selection outline

● Electric auto hand changer System configuration diagram (example)

● NPN specifications

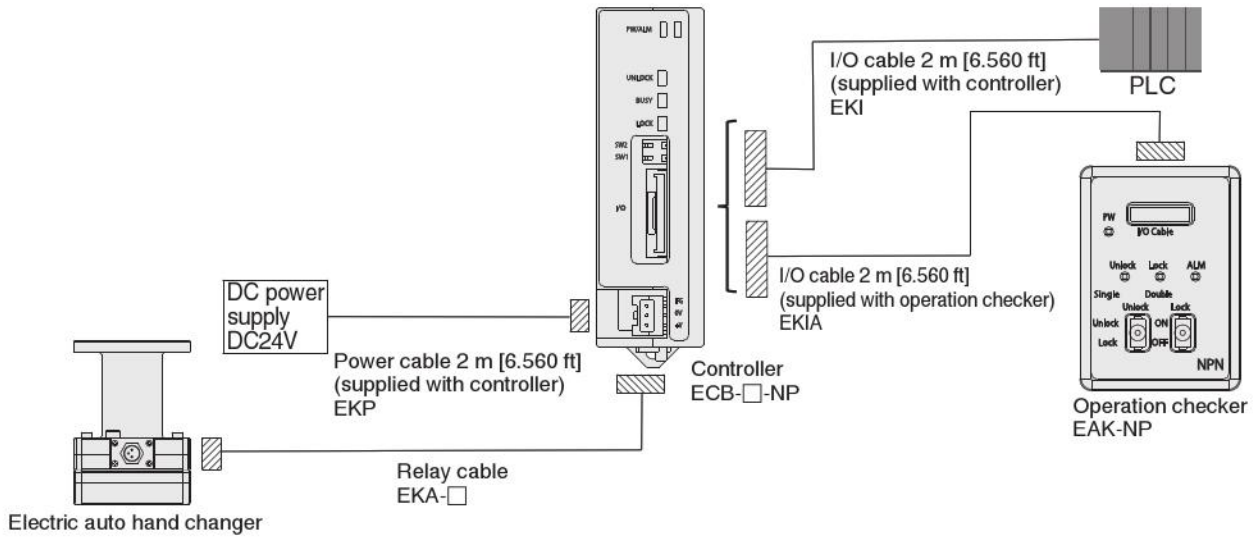

● PNP specifications

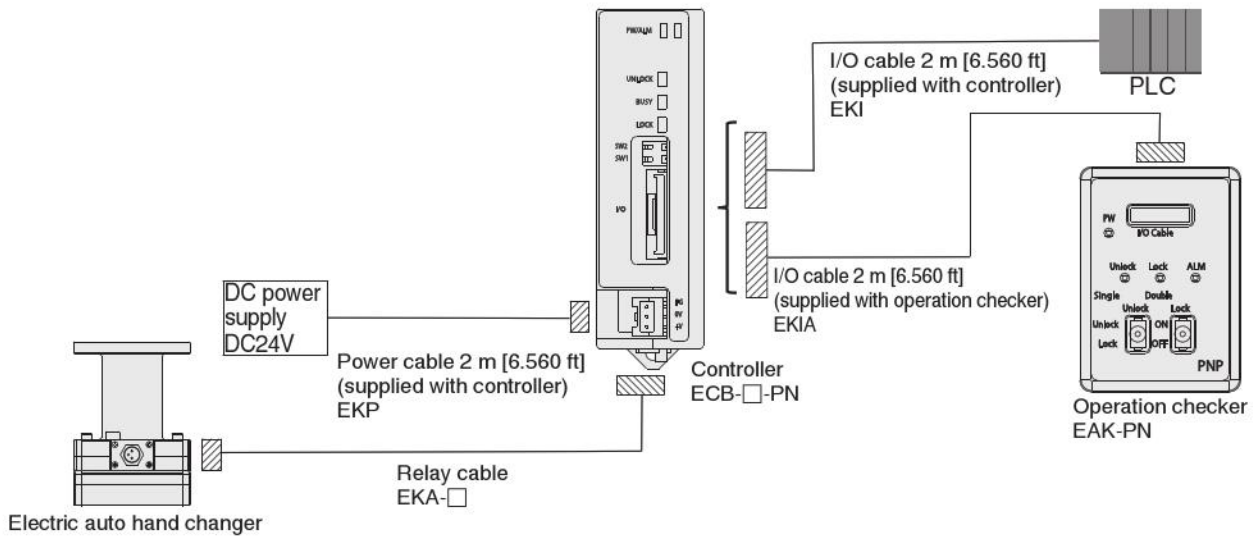

Operation checker

NPN specifications·PNP specifications



Specifications

Item	Model	EAK-NP	EAK-PN
Control method	Control input	3 points (InLock, InUnlock, InALM)	
	Control output	2 points (OutLock, OutUnlock)	
General specifications	Mass	40 g [1.41 oz]	
	Power supply voltage	Power supply from controller 24 VDC	
	Consumption current	50mA MAX	
	Power supply display	LED lights when the power is turned on	
	Operating temperature range	0 to 40 °C [32 to 104 °F]	
	Operating humidity range	35 to 85% RH (no condensation)	
	Storage temperature range	-10 to 65°C [14 to 149°F]	
Accessories	I/O cable		
Applicable controller model		ECB-□-NP	ECB-□-PN

Operation checker dimensions (mm [in.])

EAK - □
 Operation checker
 Type
NP: NPN specifications
PN: PNP specifications

* Accessories: I/O cable (for operation checker only)

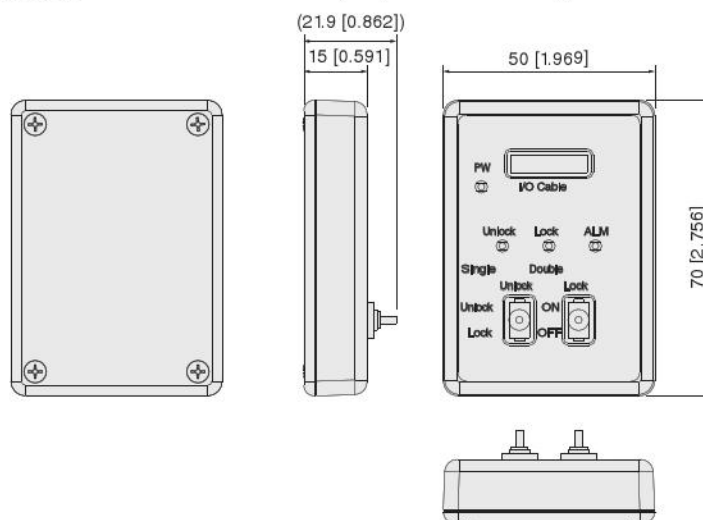

Limited Warranty

KOGANEI CORP. warrants its products to be free from defects in material and workmanship subject to the following provisions.

Warranty Period The warranty period is 180 days from the date of delivery.

Koganei Responsibility If a defect in material or workmanship is found during the warranty period, KOGANEI CORP. will replace any part proved defective under normal use free of charge and will provide the service necessary to replace such a part.

Limitations

- This warranty is in lieu of all other warranties, expressed or implied, and is limited to the original cost of the product and shall not include any transportation fee, the cost of installation or any liability for direct, indirect or consequential damage or delay resulting from the defects.

- KOGANEI CORP. shall in no way be liable or responsible for injuries or damage to persons or property arising out of the use or operation of the manufacturer's product.

- This warranty shall be void if the engineered safety devices are removed, made inoperative or not periodically checked for proper functioning.

- Any operation beyond the rated capacity, any improper use or application, or any improper installation of the product, or any substitution upon it with parts not furnished or approved by KOGANEI CORP., shall void this warranty.

- This warranty covers only such items supplied by KOGANEI CORP. The products of other manufacturers are covered only by such warranties made by those original manufacturers, even though such items may have been included as the components.

The specifications are subject to change without notice.

URL <http://www.koganei.co.jp>

E-mail: overseas@koganei.co.jp



KOGANEI CORPORATION

OVERSEAS DEPARTMENT

3-11-28, Midori-cho, Koganei City, Tokyo 184-8533, Japan
Tel: (+81)42-383-7271 Fax: (+81)42-383-7276

KOGANEI INTERNATIONAL AMERICA, INC.

48860 Millmont Drive, suite 108C, Fremont, California 94538
Tel: 1-510-744-1626 Fax: 1-510-744-1676

SHANGHAI KOGANEI INTERNATIONAL TRADING CORPORATION

RM2601-2602, Tongda Venture Building No.1, Lane 600, Tianshan Road,
Shanghai, China (200051)
Tel: 86-21-6145-7313 Fax: 86-21-6145-7323

TAIWAN KOGANEI TRADING CO., LTD

Rm. 2, 16F, No88, Sec. 2, Zhongxiao E. Rd., Zhongzheng Dist., Taipei City 100,
Taiwan(ROC)
Tel: 886-2-2393-2717 Fax: 886-2-2393-2719

KOGANEI KOREA CO., LTD

A-3001, Heungdeok IT Valley Bldg., Heungkeok 1-ro, 13, Giheung-gu, Yongin-si, Gyeonggi-do,
446-908, KOREA
Tel: 82-31-246-0414 Fax: 82-31-246-0415

KOGANEI (THAILAND) CO., LTD

555, Rasa Tower 1, 11th Fl., Unit 1107 and 1108, Phaholyothin Road, Chatuchak,
Chatuchak, Bangkok 10900
Tel: +66 (0) 2513-1228-31 Fax: +66 (0) 2513-1232

KOGANEI AUTOMATION (MALAYSIA) SDN, BHD.

Suite 29-2, Level 29, Menara 1MK, No.1, Jalan Kiara, Mont Kiara
50480, Kuala Lumpur, Malaysia
Tel: 60-12-537-7086

KOGANEI ASIA PTE. LTD.

69 Ubi Road 1, #05-18 Oxley Bizhub Singapore 408731
Tel: 65-6293-4512 Fax: 65-6293-4513