

# PRESSURE GAUGES WITH ELECTRONIC SWITCHES

EG110, EG120, EG121

Reliably measures the pulsating pressure in locations that the conventional Bourdon tube pressure gauge has always had difficulty with, and without worries about breakage. The pressure gauge comes equipped with an LED analog indication using a semiconductor pressure transducer. The electronic mode, without any mechanical moving parts, assures longer operating life, better reliability, and higher precision than the Bourdon tube pressure gauge.

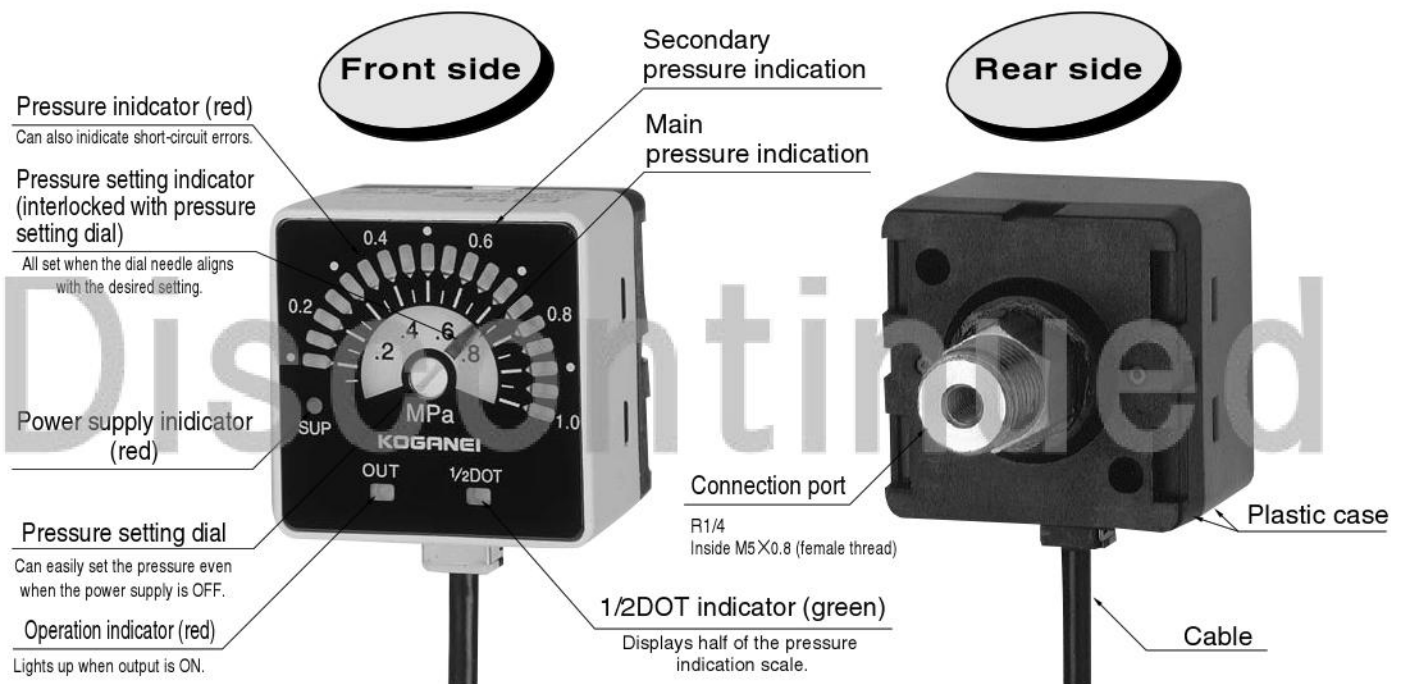

## Order Codes

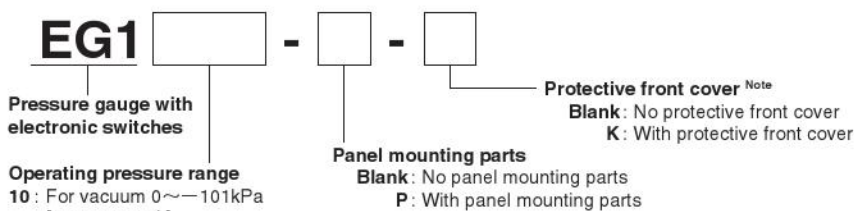

- Operating pressure range**
- 10 : For vacuum 0~101kPa [0~14.6psi.]
  - 20 : For positive pressure 0~1MPa [0~145psi.]
  - 21 : For positive pressure 0~100kPa [0~14.5psi.]

Note: The protective front cover may be selected only when the panel mounting parts are selected. The protective front cover cannot by itself be mounted on the pressure gauge with electronic switches.

## Additional parts (to be ordered separately)



# Specifications

## ● Pressure gauges with electronic switches

Item	Type Model	Vacuum	Positive pressure			
		EG110	100kPa type EG121	1MPa type EG120		
Rating	Rated pressure range	0~-101kPa [0~-14.6psi.]	0~100kPa [0~14.5psi.]	0~1.0MPa [0~145psi.]		
	Pressure setting range	-10~-90kPa [-1.5~-13.1psi.]	10~90kPa [1.5~13.1psi.]	0.1~0.9MPa [14.5~131psi.]		
	Indicator lamp	Pressure indicator	Red LED: Bar display Green LED: 1/2 dot display	( indication: Positive pressure type→Clockwise rotation, Vacuum pressure type→Counterclockwise rotation ) Indication cycle: 10ms or less		
		Operation indicator	Red LED (when output is ON, lights up)			
		Power supply indicator	Red LED (when power supply is ON, lights up)			
	Proof pressure	490kPa [71psi.]		1.47MPa [213psi.]		
	Applicable media	Air or non-corrosive gas				
	Voltage	DC12~24V±10%, ripple tolerance P-P ±10% or less				
	Consumption current	40mA or less				
	Output	NPN transistor open collector (equipped with short-circuit protection function) ●Maximum inrush current 100mA ●Applied voltage DC30V max. ●Residual voltage 1V max. (inrush current 100mA) / 0.4V max. (inrush current 16mA) Output operation NO, NC (selectable by using the mode switching input line)				
Performance	Pressure sensitive element	Semiconductor type				
	Power supply voltage fluctuation	±1% F.S. or less				
	Non-linearity	±2% F.S. or less				
	Hysteresis	5% F.S.				
	Repeatability	±1% F.S. or less				
	Temperature characteristics	±5% F.S. or less (at temperature range of 0~50°C [32~122°F], as reference point 25°C [77°F])				
	Setting indicator accuracy	±2.5% F.S. or less (at median value)				
	Response time	10ms or less				
Environment	Operating ambient temperature	0~50°C [32~122°F], In storage : -10~60°C [14~140°F] (without condensation or freezing)				
	Operating ambient humidity	35~85% RH				
	Protective structure	IP40 (IEC144)				
	Vibration resistance	10~150Hz (total amplitude 0.75mm [0.03in.]), 2 hours in each of the XYZ directions (de-energized)				
	Shock resistance	98m/s <sup>2</sup> [10G], 3 times in each of the XYZ directions (de-energized)				
	Dielectric strength	AC1000V one minute (between charging part and case)				
Structure/ Materials	Insulation resistance	20MΩ or more (at DC500V megger)				
	Noise resistance	●Power supply line 240V or more ●Radiation 300V or more (in a pulse width 0.5μs by noise simulator)				
	Grounding method	Floating				
	Port size	R1/4, with M5×0.8 female thread inside				
	Front case, rear case	PBT				
	Front name plate	PC				
Structure/ Materials	Connection port	Brass (nickel plated)				
	Cable	0.18SQ, 4-lead, Cabtyre cable φ 3.7 [0.146in.], 0.5m [1.6ft.]				
Mass	85g [3.0oz.]					

## Dimensions (mm)

### ● EG1□-□

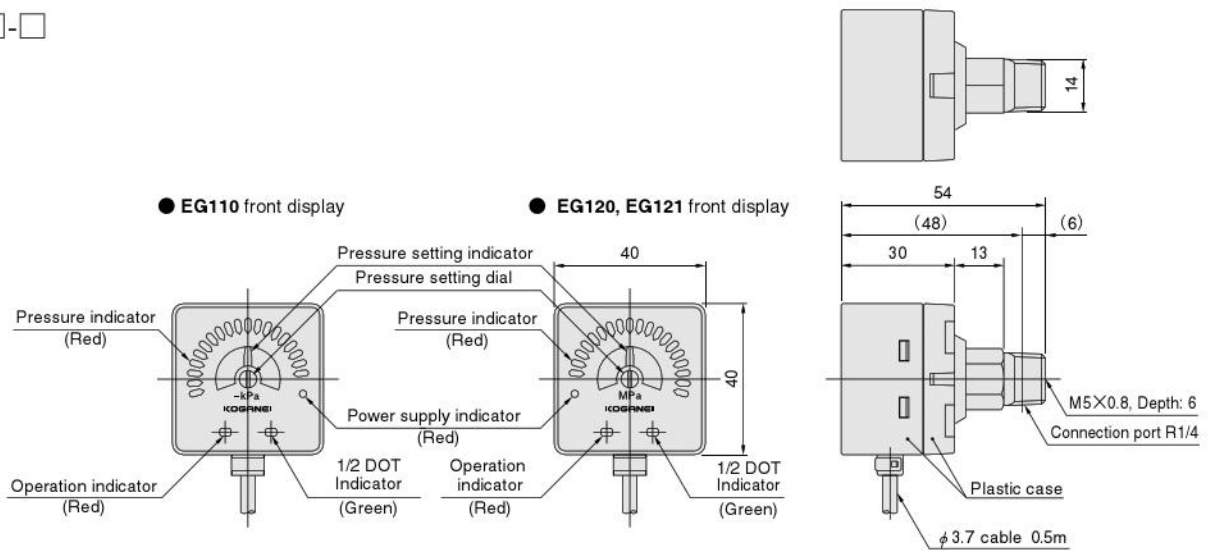

### <Drawings for panel mounting parts>

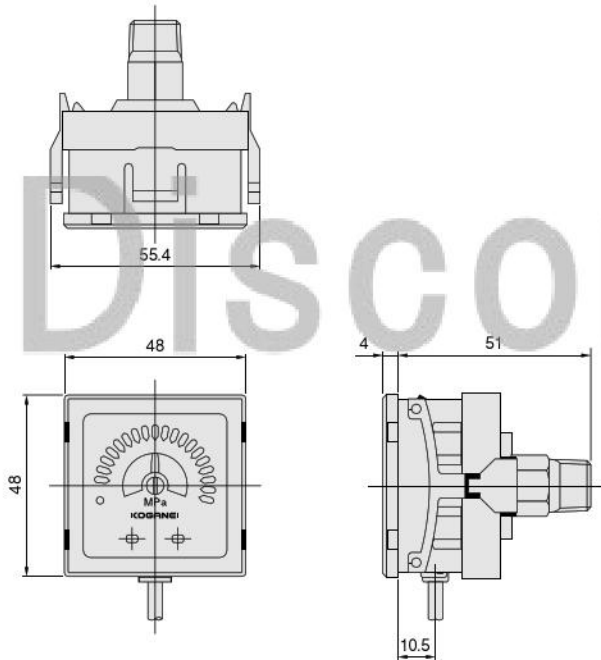

### ● Protective front cover

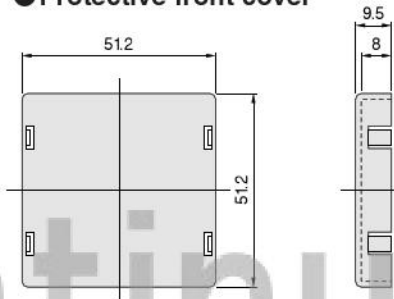

### ● Cut panel dimensions (mm)

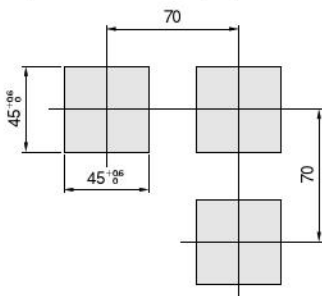

- Notes:
1. The mounting plate thickness should be 1 to 3.2mm.
  2. The cut panel dimensions are  $45^{+0.06}_0 \times 45^{+0.06}_0$  mm.
  3. If mounting in a series, space the units at intervals of the value shown in the figure above or greater.
  4. Conformity **DIN43700**

## Operating Pressure Settings

1) Pressure indication: The red LED bar indication has a lower resolution that is easy to read. In addition, the green LED "1/2DOT" offers pressure indication at higher resolution.

### ● (Example) EG120

Indicated pressure: 0.8MPa

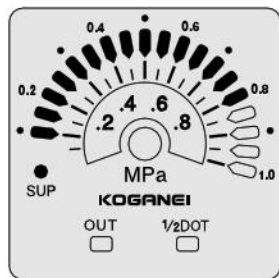

0.825MPa



Green LED lights up

0.85MPa



### ● (Example) EG110

Indicated pressure: -40kPa

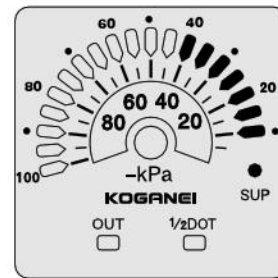

-42.5kPa

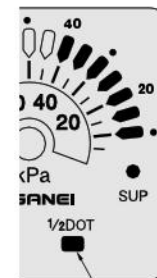

Green LED lights up

-45kPa

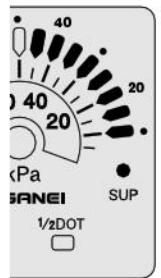

2) Pressure setting: The pressure setting uses (1) the pressure setting dial to move (2) the pressure setting indicator to align to (3) pressure scale.

### <Operation parts>

#### ●EG120

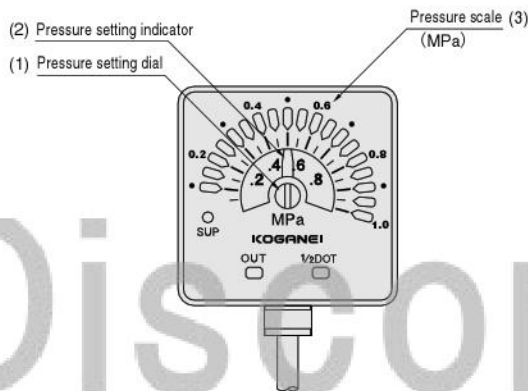

#### ●EG110

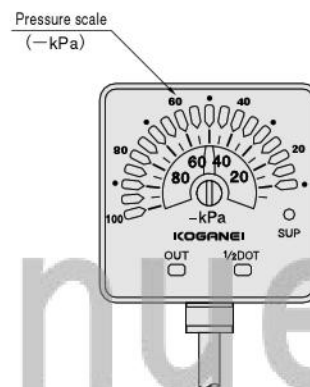

#### ●EG121

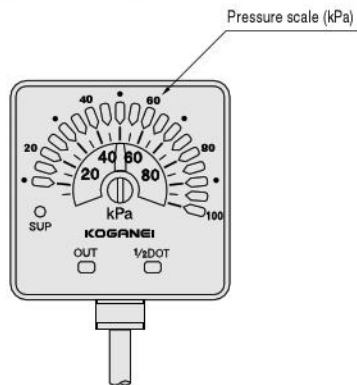

To set the pressure, insert a small screwdriver into the pressure setting dial, and rotate the dial.

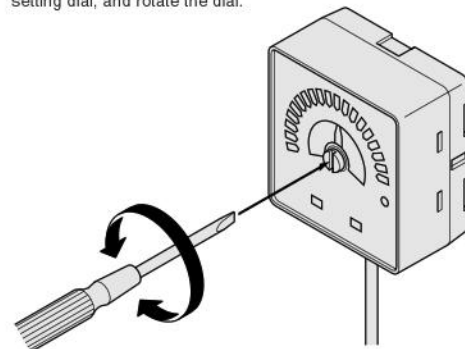

### 3) Output operation

#### NO type

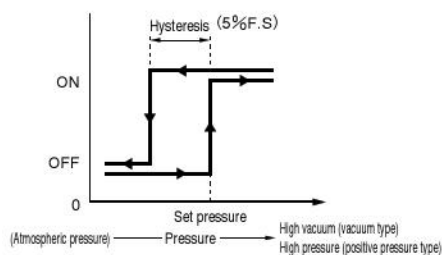

#### NC type

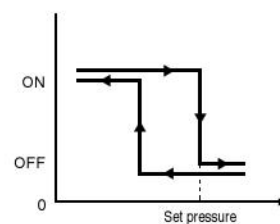

※ To switch the output operation, change the mode switching input line.

(Status for mode switching input line) Open : NO type  
GND connection : NC type

# Handling Instructions and Precautions

## ● Pressure gauges with electronic switches

### 1 Input/output circuit diagram

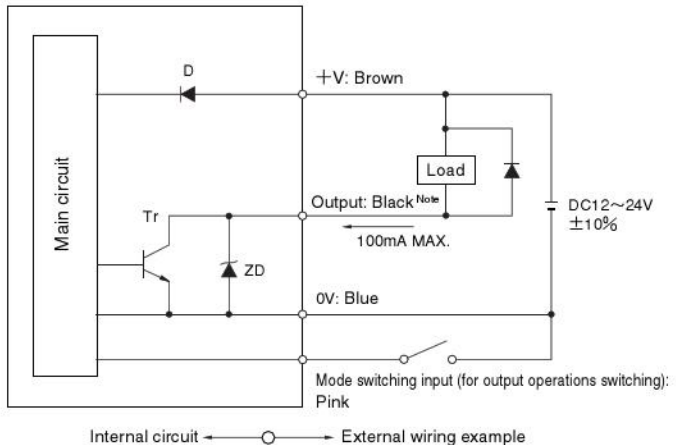

Note: When the mode switching input line is open, the output is NO.  
When the mode switching input line is closed, the output is NC.

- D : Reverse current protection diode for power supply
- Tr : NPN output transistor
- ZD : Zener diode for surge voltage absorption

### 2 Precautions

#### Power supply

- If using a commercial switching regulator for the power supply, always ground it with a frame ground (F.G.) terminal.
- Avoid using the product while it is in a transitory state (about 0.5sec) immediately after the power supply has been switched on.
- For direct current power supply, always use an insulated transformer. Use of an autotransformer (single-winding transformer) could damage the product and the power supply.
- If surges appear in the power supply, connect a surge absorber to the source of the surge.

#### Input/output

- Use surge protection when connecting the inductive loads such as DC relays to the load.

#### Wiring

- Avoid wiring parallel to high voltage lines or power lines, or use in the same wiring conduits. Induction could cause erratic operation.
- Always shut off the power supply before performing wiring work.
- Keep wiring lengths as short as possible to avoid electric noise problems.

#### Environment

- When using equipment that could be sources of electric noise (such as switching regulators, inverter motors, etc.) around the sensor installation area, ground them with an equipment's frame ground (F.G.) terminal.
- Avoid use in steamy or dusty locations, or in locations that are directly subject to dripping water.
- The product cannot be used when the media or the ambient atmosphere contains any of the substances listed below.  
Organic solvents, phoshate ester type hydraulic oil, sulphur dioxide, chlorine gas, or acids, etc.

#### Detection

- Do not put wires or other foreign objects inside the pressured area.
- This product is for use with non-corrosive gases. Be aware that it cannot be used with liquids or with corrosive gases.

#### Mounting

- Always thoroughly blow off (use compressed air) or air blowing the tubing before piping. Be careful to prevent chips, sealing tape, or rust, etc., generated during plumbing from entering into the pipes.
- When connecting a fitting to a piping connection port, mount by using a wrench on the hexagonal section of the port. The tightening torque for R1/4 (male thread) should be 20N·m [14.8ft·lbf] or less, and for M5×0.8 (female thread), 2.0N·m [1.48ft·lbf] or less.
- Never perform tightening on any other section.

#### Setting

- Use a setting value that provides plenty of margin for the operating ambient temperature, power supply, voltage, and other conditions.

### 3 Body mounting

- As the mounting screws for the piping connection port are the R1/4 tapered thread or the M5 female thread, various commercial fittings can be used.
- For direct mounting on piping, use a 14mm wrench on the hexagonal section, do not exceed a torque value of 20N·m [14.8ft·lbf]. Do not use the wrench on the body case. When the M5 female thread is used, do not exceed a torque value of 2.0N·m [1.48ft·lbf].

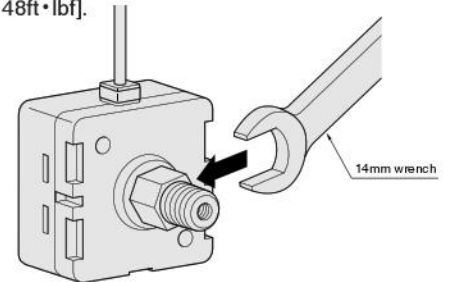

### 4 Mounting parts for panel mounting, and protective front cover

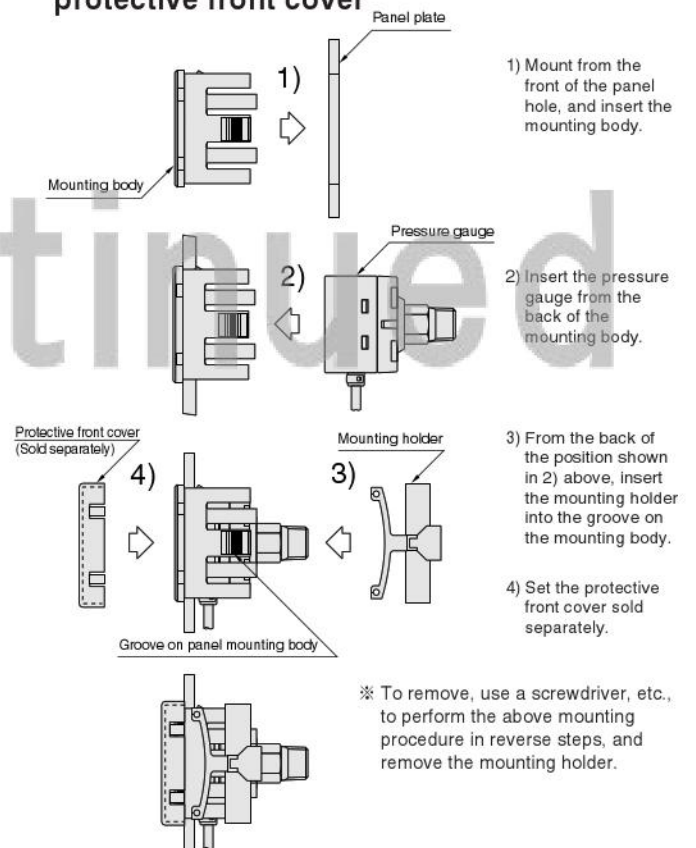

### 5 Error indication

#### <Short-circuit error>

- If the LED indicates as shown below, it means that over current is flowing to the load, and output has short-circuited. First, shut off the power supply, and then check the load and output.

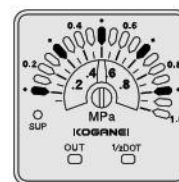

EG120

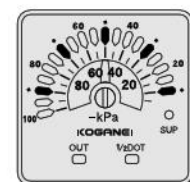

EG110

# Discontinued