

Small, easy-to-use, simple construction valves!
 Suitable for various needs and offering high-performance control, while achieving still lower power consumption and quicker response!

New Standard Valve SOLENOID VALVES EA, EB SERIES

SOLENOID VALVES EA series

(2, 3, 5-port pilot type solenoid valves)

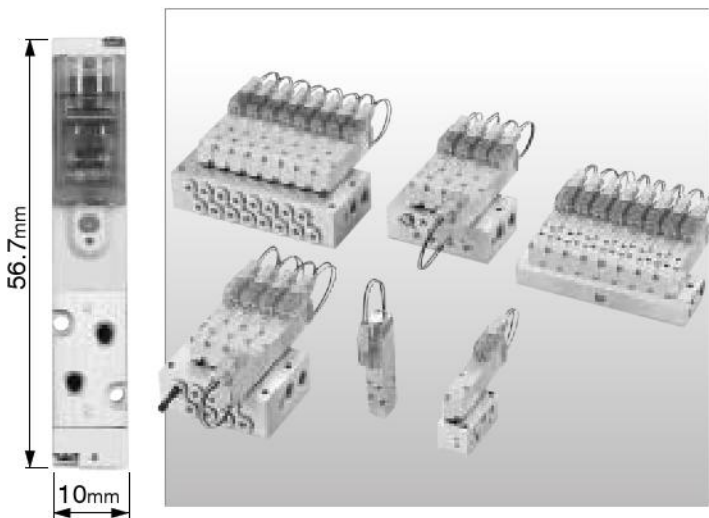

Provides reliable performance for all situations in which solenoid valves are required, in the manufacturing lines, in machinery, or in equipment.
 A NEW standard in compact valves!

● **Space Saving—Thin and compact size**

Valve width: 10mm [0.394in.]
 Valve length: 56.7mm [2.232in.] (EA series)
 53mm [2.087in.] (EB series)
 (for standard type)

● **Flow—Efficient flow rate**

Sonic conductance C: 0.26dm³/(s·bar)
 (Effective area: 1.3mm² [Cv: 0.07])
 Optimum for pilot-operated valves, and for operating up to $\phi 25$ [0.984in.] bore size cylinders.

● **Response—Fast response time**

Response time: When ON, 6ms or below
 When OFF, 7ms or below
 (in the case of quick response type single solenoids)

● **Power—Lower power consumption**

Standard type: 0.55W, Low current type: 0.15W

● **Reliability—Improved reliability**

New solenoid and stem construction resulting from years of our valve technology experience have boosted operating life, response, and other basic performance features.

● **Environmental Protection—Improved performance**

Grommet type valves offer moisture proof specifications.

SOLENOID VALVES EB series

(2, 3-port pilot type solenoid valves)

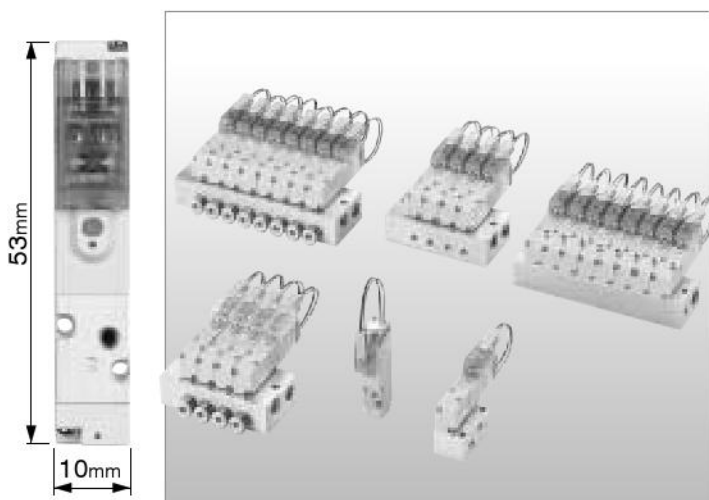

—Product Variety—
Providing a wide product range

Solenoid Valves EA Series

Single solenoid: EA10□F5

Double solenoid: EA10□F6

116

Solenoid Valves EB Series (2, 3-port valves)

Normally closed (NC): EB10□F1, EB10□F3

Normally open (NO): EB10□F2, EB10□F4

128

Single unit (base piping)

Single solenoid: EA10□A5-25

Double solenoid: EA10□A6-25

116

Normally closed (NC): EB10□A1-25, EB10□A3-25

Normally open (NO): EB10□A2-25, EB10□A4-25

128

F type manifold (direct piping type)

Manifold for combination mounting of 2, 3, 5-port valves

EAM□F

118

Manifold for 2, 3-port valves

EBM□F

129

A, AJ type manifolds (base piping type)

Manifold for combination mounting of 2, 3, 5-port valves

EAM□A, EAM□AJ

118

Manifold for 2, 3-port valves

EBM□A, EBM□AJ

129

Function-specific solenoids (for both EA and EB series)

- Standard, low current and quick response types can be identified by the color of their housings.

Standard type: Blue

Low current type: Light blue

Quick response type: White



Solenoid

Internal circuit

●DC12V, DC24V

(Standard type)

Solenoid with LED Indicator and surge suppression

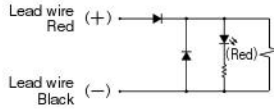

●DC24V

(Low current, quick response types)

Solenoid with LED Indicator and surge suppression

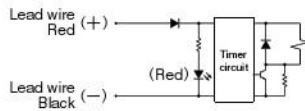

- Cautions:**
1. Do not apply megger between the pins.
 2. Leakage current inside the circuit could result in failure of the solenoid valve to return to the rest position or other erratic operation. Always use it at less than the allowable leakage current shown in the solenoid specifications on p.109 and 121. If circuit conditions, etc. cause the leakage current to exceed the maximum allowable leakage current, consult us.
 3. For the double solenoid configuration, avoid energizing both solenoids simultaneously.
 4. The standard housing type is colored blue, while the low current type is light blue, and the quick response type is white.
 5. The low current and quick response types will not activate when the power supply voltage is raised too slowly. Always apply the appropriate voltage.

Operating principles of low current and quick response types

The low current and quick response types use a timer circuit, as shown above, that achieves power savings by switching to the holding operations mode after a certain period of time and operates at about 1/3 of the starting power consumption.

●Power waveform for low current type

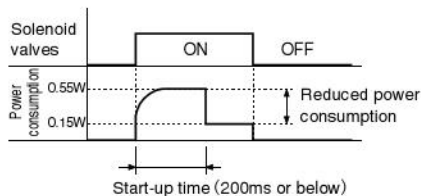

●Power waveform for quick response type

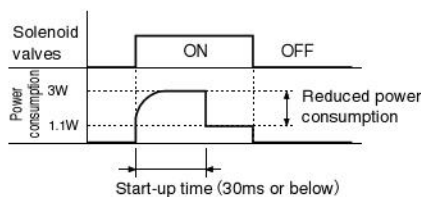

Plug connector

Attaching and removing plug connector

Use fingers to insert the connector into the pin, push it in until the lever claw latches onto the protruded section of the connector housing, and complete the connection.

To remove the connector, squeeze the lever along with the connector, lift the lever claw up from the protruded section of the connector housing, and pull it out.

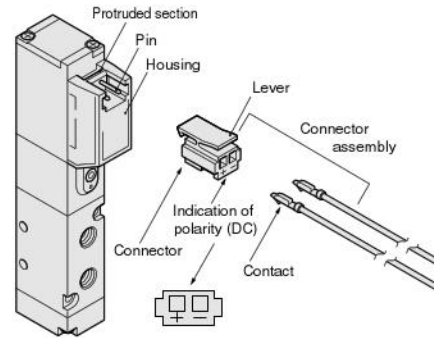

Crimping of connecting lead wire and contact

To crimp lead wires into contacts, strip off 4mm [0.16in.] of the insulation from the end of the lead wire, insert it into the contact, and crimp it. Be sure at this time to avoid catching the insulation on the exposed wire crimping section.

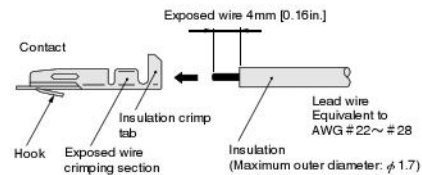

- Cautions:**
1. Do not pull hard on the lead wire.
 2. Always use a dedicated tool for crimping of connecting lead wire and contact.
Contact: Model 702062-2M
Manufactured by Sumiko Tech, Inc.
Crimping tool: Model F1-702062
Manufactured by Sumiko Tech, Inc.

Attaching and removing contact and connector

Insert the contact with lead wire into a plug connector hole until the contact hook latches on and is secured to the plug connector. Confirm that the lead wire cannot be easily pulled out.

To remove it, insert a tool with a fine tip (such as a small screwdriver) into the rectangular hole on the side of the plug connector to push up on the hook, and then pull out the lead wire.

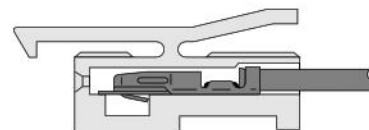

- Cautions:**
1. Do not pull hard on the lead wire. It could result in defective contacts, breaking wires, etc.
 2. If the pin is bent, use a small screwdriver, etc. to gently straighten out the pin, and then complete the connection to the plug connector.



Manual override

Non-locking type

To operate the manual override, press it all the way down.

For the single solenoid, the valve works the same as when in the energized state as long as the manual override is pushed down, and returns to the rest position upon release.

For the double solenoid, pressing the manual override on the 14 (SA) side switches the 14 (SA) to the energized state, and the unit remains in that state even after the manual override is released. To return it to the rest position, operate the manual override on the 12 (SB) side. This is the same for the solenoid 12 (SB).

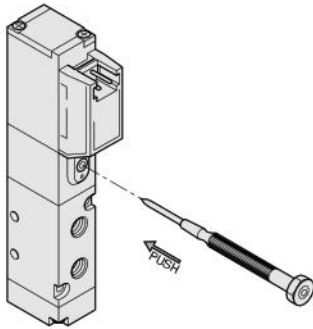

Locking type

To lock the manual override, use a small screwdriver to push down on the manual override all the way down and turn it clockwise 45 degrees. When locked, turning the manual override 45 degrees in the counterclockwise direction returns it to its original position, and releases the lock. (Excluding the quick response type)

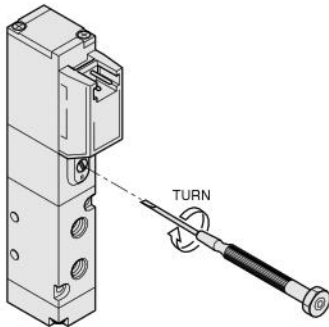

- Cautions:**
1. The **EA, EB** series valves are pilot type solenoid valves. As a result, the manual override cannot switch the main valve without air supplied from the 1(P) port.
 2. Always release the lock of the locking type manual override before commencing normal operation.
 3. Do not attempt to operate the manual override with a pin or other object having an extremely fine tip. It could result in damage to the manual override.

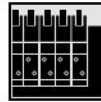

Manifold

Mounting valves on manifold

When mounting valves on manifold, the recommended tightening torque for the valve mounting screw is 14.7N·cm {1.5kgf·cm} [1.3lbf·in.].

Tube

1. Attaching and removing tubes

For tube connection, insert an appropriate size tube until it makes contact with the tube stopper, and lightly pull it to check the connection.

For tube removal, push the tube against the tube stopper, then push the release ring and at the same time pull the tube out.

2. Either a nylon or urethane tube can be used.

Use tubes with an outer diameter tolerance within $\pm 0.1\text{mm}$ [0.004in.] of the nominal diameter, and ensure the ovalness (difference between the large diameter and small diameter) is 0.2mm [0.008in.] or less.

(Using a Koganei tube is recommended.)

- Cautions:**
1. Do not use extra-soft tubes since their pull-out strength is significantly reduced.
 2. Only use tubes without scratches on their outer surfaces. If a scratch occurs during repeated use, cut off the scratched section.
 3. Do not bend the tube excessively near the fittings. The minimum bending radius is as shown in the table below.
 4. When attaching or removing tubes, always stop the air supply. In addition, always confirm that air has been completely exhausted from the manifold.

| Tube size | Minimum bending radius | |
|-----------|------------------------|---------------|
| | Nylon tube | Urethane tube |
| $\phi 3$ | — | 7 [0.28] |
| $\phi 4$ | 20 [0.79] | 10 [0.39] |
| $\phi 6$ | 30 [1.18] | 15 [0.59] |
| $\phi 8$ | 50 [1.97] | 20 [0.79] |

Solenoid Valves EB Series

SOLENOID VALVES EA, EB SERIES

EB

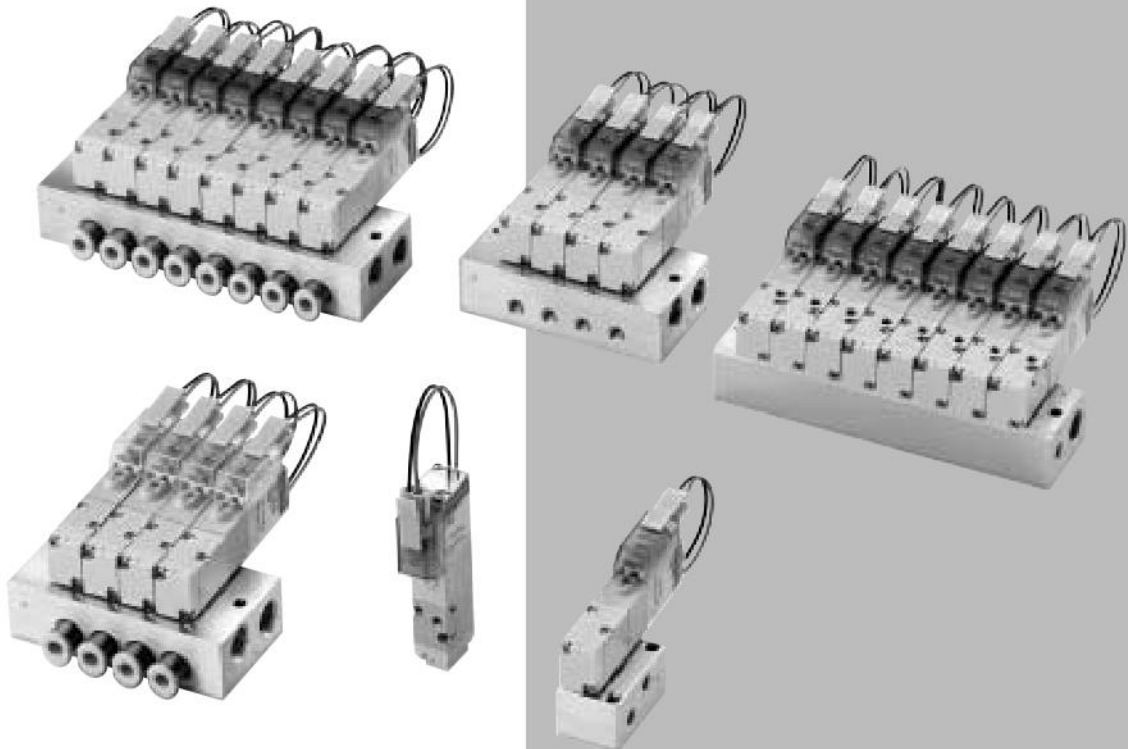

EB SERIES SPECIFICATIONS

Specifications

Basic Models and Functions

| | | |
|---------------------|--|--|
| Basic model | For direct piping, F type manifold | EB10□F1 EB10□F2 EB10□F3 EB10□F4 |
| | For base piping, A, AJ type manifolds | EB10□A1 EB10□A2 EB10□A3 EB10□A4 |
| Item | | |
| Number of positions | | 2 positions |
| Number of ports | | 2, 3 ports |
| Valve function | | Single solenoid NC, NO |

Remark: For the optional specifications and order codes, see p.125.

Specifications

| | | |
|--|---|---|
| Basic model | For direct piping, F type manifold | EB10□F1 EB10□F2 EB10□F3 EB10□F4 |
| | For base piping, A, AJ type manifolds | EB10□A1 EB10□A2 EB10□A3 EB10□A4 |
| Item | | |
| Media | | Air |
| Operation type | | Internal pilot type |
| Flow rate characteristics ^{Note 1} | Sonic conductance C $\text{dm}^3/(\text{s} \cdot \text{bar})$ | Base piping (A, AJ type): 0.26 |
| | Effective area S (Cv) mm^2 | Direct piping (F type): 1.3 (0.07) |
| Port size ^{Note 2} | | M3×0.5 |
| Lubrication | | Not required |
| Operating pressure range | MPa (kgf/cm ²) [psi.] | 0.2~0.7 [2~7.1] [29~102] |
| Proof pressure | MPa (kgf/cm ²) [psi.] | 1.05 [10.7] [152] |
| Response time ^{Note 3} ON/OFF | Standard type | 10/20 or below |
| | Low current type (L) | 10/50 or below |
| | Quick response type (S) | 6/7 or below |
| Maximum operating frequency | Standard type | 5 |
| | Low current type (L) | 2 |
| | Quick response type (S) | 10 |
| Operating temperature range (atmosphere and media) | °C [°F] | 5~50 [41~122] |
| Shock resistance | m/s^2 [G] | 1373.0 [140] (Axial direction 294.2 {30}) |
| Mounting direction | | Any |

Notes: 1. For details, see the flow rate characteristics on p.122.

2. For details, see the port size on p.122.

3. Values when air pressure is 0.5MPa [73psi].

Solenoid Specifications

| Item | Rated voltage | DC24V | | | | |
|---|--|-----------------------------------|--------------------------|-----------------------------|--------------------------------|-----|
| | | DC12V (Standard type) | DC24V (Standard type) | DC24V (Low current type) | DC24V (Quick response type) | |
| Operating voltage range | V | 10.8~13.2 (12±10%) | 21.6~26.4 (24±10%) | 21.6~26.4 (24±10%) | 21.6~26.4 (24±10%) | |
| Standard type | Current (when rated voltage is applied) mA (r.m.s) | 46 | 23 | — | — | |
| | Power consumption W | 0.55 | 0.55 | — | — | |
| Low current type Quick response type | Current (when rated voltage is applied) | Starting mA | — | 23 | 125 | |
| | | Holding mA | — | — | 6.3 | 46 |
| | Power consumption | Starting W | — | — | 0.55 | 3 |
| | | Holding W | — | — | 0.15 | 1.1 |
| | Start-up time (standard time) ms | — | — | 200 or below | 30 or below | |
| Allowable leakage current | mA | 2 | 1 | 0.5 | 4 | |
| Insulation resistance | MΩ | Over 100 (value at DC500V megger) | | | | |
| Color of LED indicator | | Red | | | | |
| Surge suppression (as standard) | | Flywheel diode | | | | |

Port Size

| Specification | Port | 2(A) | 1(P) | 3(R) | PR |
|---------------|-----------------------------|----------------------------|--------|--------|------------------------|
| Single unit | Direct piping | M3×0.5 | M3×0.5 | M3×0.5 | — |
| | Base piping (with sub-base) | M5×0.8 | M5×0.8 | M5×0.8 | M5×0.8 |
| Manifold | F type | M3×0.5 | M5×0.8 | Rc1/8 | Collected at 3(R) port |
| | A type | M5×0.8 | Rc1/8 | Rc1/8 | |
| | AJ type | Quick fitting for $\phi 4$ | Rc1/8 | Rc1/8 | |

Flow Rate Characteristics

The test method for flow rate characteristics conforms to JIS B 8390:2000 (test method for pneumatic equipment — equipment for compressible fluids — flow rate characteristics).

● When used as a single unit

| Basic model | | Flow path | Sonic conductance C dm ³ /(s·bar) | Critical pressure ratio b | Effective area S [Cv] mm ² | |
|--------------------------------|--------------------|---------------|---|---------------------------|--|---|
| Direct piping | EB10□F1 EB10□F2 | 1 (P) → 2 (A) | — | — | 1.30 [0.072] | 0.75 [0.042] <small>Note1</small> (with fittings) |
| | EB10□F3 EB10□F4 | 2 (A) → 3 (R) | — | — | | |
| Base piping (with sub-base) | EB10□A1 EB10□A2 | 1 (P) → 2 (A) | 0.23 | 0.05 | 1.15 [0.064] <small>Note3</small> | |
| | EB10□A3 EB10□A4 | 2 (A) → 3 (R) | 0.23 | 0.38 | 1.15 [0.064] <small>Note3</small> | |

● When mounted on a manifold

| Basic model | | Flow path | Sonic conductance C dm ³ /(s·bar) | Critical pressure ratio b | Effective area S [Cv] mm ² | |
|--|--------------------|---------------|---|---------------------------|--|--|
| F type manifold (direct piping type) | EB10□F1 EB10□F2 | 1 (P) → 2 (A) | — | — | 1.30 [0.072] | 0.80 [0.044] <small>Note2</small> (with fitting) |
| | EB10□F3 EB10□F4 | 2 (A) → 3 (R) | — | — | | |
| A, AJ type manifolds (base piping type) | EB10□A1 EB10□A2 | 1 (P) → 2 (A) | 0.26 | 0.21 | 1.30 [0.072] <small>Note3</small> | |
| | EB10□A3 EB10□A4 | 2 (A) → 3 (R) | 0.24 | 0.46 | 1.20 [0.067] <small>Note3</small> | |

Notes: 1. Quick fitting TS3-M3Ms have been mounted on connection ports 1(P), and 2(A).

2. Quick fitting TS3-M3M has been mounted on connection port 2(A).

3. Figures in effective area S are calculated based on sonic conductance C ($S=5.0 \times C$)

Base piping type

(Effective area S = 1.3mm² [Cv: 0.072])

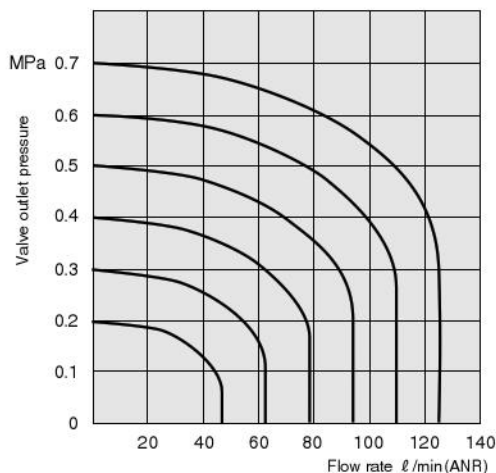

Direct piping type with fittings

(Effective area S = 0.75mm² [Cv: 0.042])

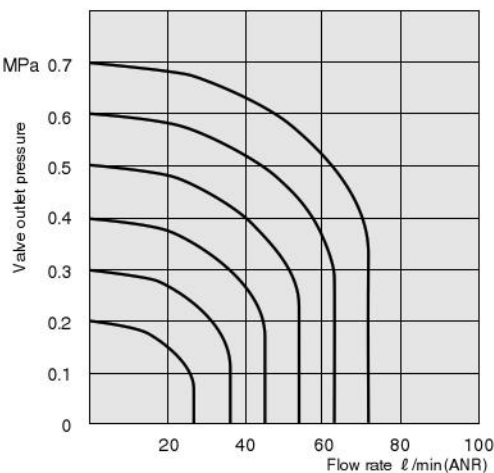

- Graphs use flow rate calculations based on the discharge method.
- Use the flow rate as a guide.

1MPa = 145psi., 1 l/min = 0.0353ft³/min.

Mass

Single Valve Unit Mass

g [oz.]

| Basic model | Mass | Additional mass | |
|-------------|-----------|---------------------------------|---------------------|
| | | -21 (with bottom mounting base) | -25 (with sub-base) |
| EB10□F1 | 22 [0.78] | 4 [0.14] | — |
| EB10□F2 | 22 [0.78] | | |
| EB10□F3 | 22 [0.78] | | |
| EB10□F4 | 22 [0.78] | | |
| EB10□A1 | 22 [0.78] | — | 17 [0.60] |
| EB10□A2 | 22 [0.78] | | |
| EB10□A3 | 22 [0.78] | | |
| EB10□A4 | 22 [0.78] | | |

Manifold Mass

g [oz.]

| Basic model | Mass calculation of each unit (n=number of units) | Block-off plate |
|-------------|--|-----------------|
| EBM□F | $(10.5 \times n) + 15$ $[(0.37 \times n) + 0.53]$ | 2 [0.07] |
| EBM□A | $(12.5 \times n) + 19$ $[(0.44 \times n) + 0.67]$ | 3 [0.11] |
| EBM□AJ | $(14 \times n) + 24$ $[(0.49 \times n) + 0.85]$ | 3 [0.11] |

Calculation example: **EBM8AJ**

stn.1~8 EB10A3-PS-D4

$$(14 \times 8) + 24 + (22 \times 8) = 312\text{g [11.01oz.]}$$

2-port

Normally closed (NC)

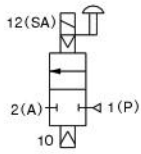

Normally open (NO)

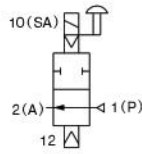

EB10F1
De-energized

EB10F2
De-energized

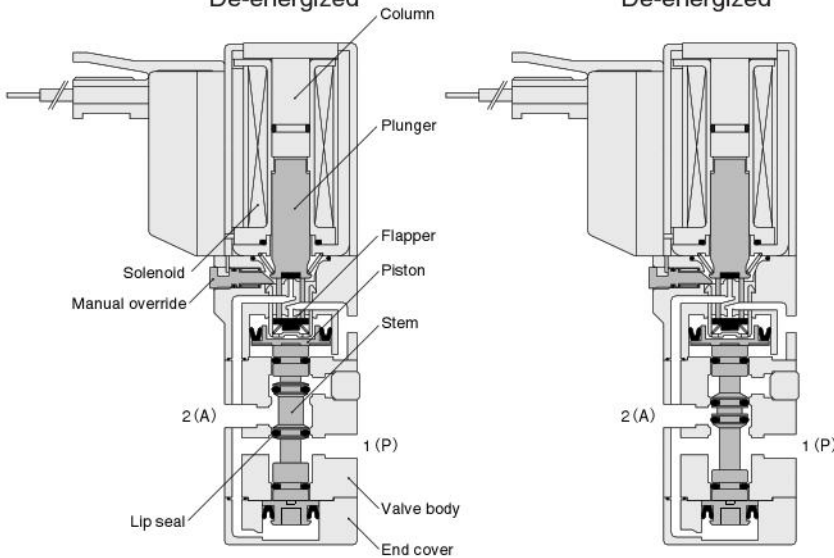

Major Parts and Materials

| Parts | Materials |
|-----------------|----------------------------|
| Body | Aluminum alloy |
| Stem | (anodized) |
| Lip seal | Synthetic rubber |
| Flapper | |
| Valve | |
| Mounting base | Mild steel (zinc plated) |
| Sub-base | Aluminum alloy (anodized) |
| Plunger | Magnetic stainless steel |
| Column | Steel |
| End cover | Plastic |
| Manifold | |
| Body | Aluminum alloy (anodized) |
| Block-off plate | Mild steel (nickel plated) |
| Seal | Synthetic rubber |

3-port

Normally closed (NC)

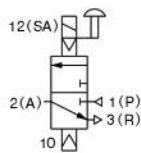

Normally open (NO)

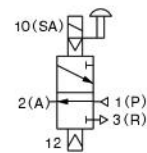

EB10F3
De-energized

EB10F4
De-energized

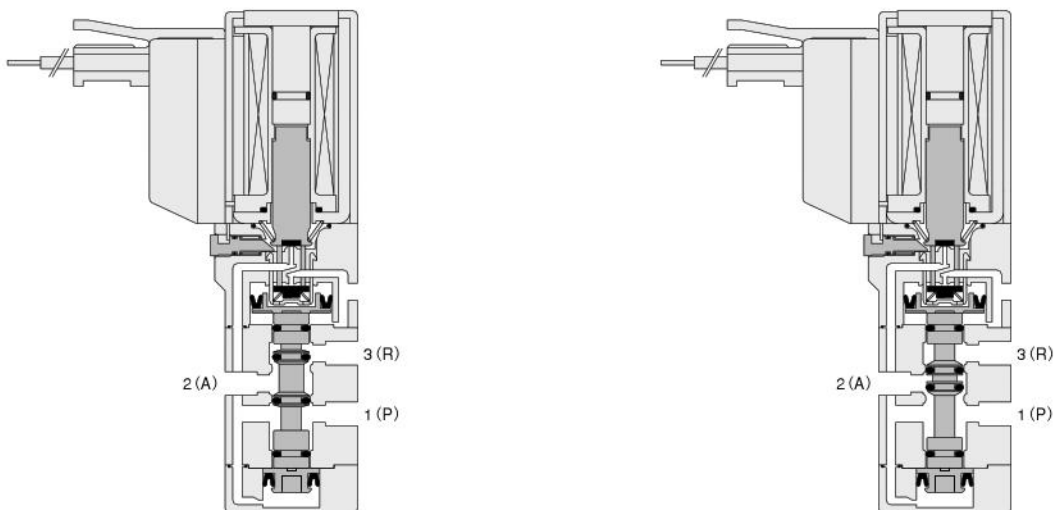

EB Series Single Valve Unit Order Codes



Model

EB10

Standard type

EB10L

Low current type

EB10S

Quick response type

Valve specification

F1, A1: 2-port normally closed (NC)

F2, A2: 2-port normally open (NO)

F3, A3: 3-port normally closed (NC)

F4, A4: 3-port normally open (NO)

Mounting base

Without mounting base

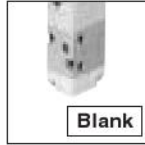

With mounting base

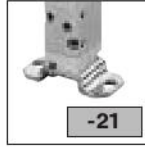

Sub-base

Without sub-base

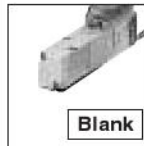

With sub-base

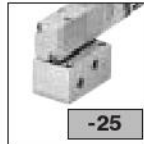

Muffler

Without muffler

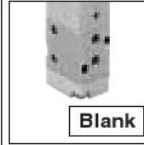

With muffler for direct piping^{Note1}

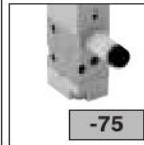

With muffler for sub-base piping^{Note2}



Manual override

Non-locking type

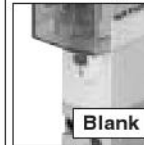

Locking type^{Note3}

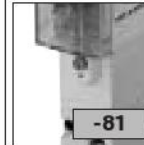

Wiring specification

S type plug connector
Lead wire 300mm

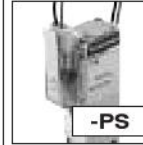

L type plug connector
Lead wire 300mm

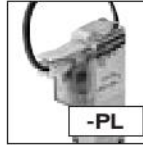

S type plug connector
Lead wire 1000mm

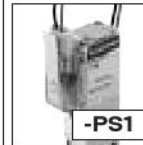

L type plug connector
Lead wire 1000mm

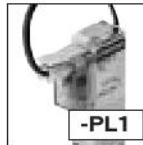

S type plug connector
Lead wire 3000mm

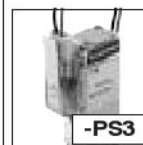

L type plug connector
Lead wire 3000mm

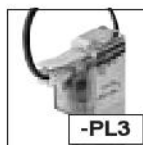

S type plug connector
Without connector ass'y

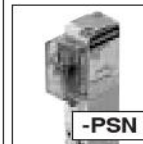

L type plug connector
Without connector ass'y

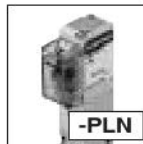

Grommet type^{Note4}
Lead wire 300mm
(moisture proof specification)



Voltage

-D4

DC24V

-D5

DC12V^{Note5}

300mm = 11.8in.
1000mm = 39in.
3000mm = 118in.

| | Model | Valve specification | Mounting base | Sub-base | Muffler | Manual override | Wiring specification | Voltage |
|---------------|------------------------|--------------------------|---------------|--------------|-------------------------------|-------------------------------|--|-----------------------------|
| Direct piping | EB10 EB10L EB10S | F1 F2 F3 F4 | Blank -21 | | Blank -75 ^{Note1} | Blank -81 ^{Note3} | -PS -PS1 -PS3 -PSN -PL -PL1 -PL3 -PLN -GL ^{Note4} | -D4 -D5 ^{Note5} |
| Base piping | EB10 EB10L EB10S | A1 A2 A3 A4 | | Blank -25 | Blank -75 ^{Note2} | Blank -81 ^{Note3} | -PS -PS1 -PS3 -PSN -PL -PL1 -PL3 -PLN -GL ^{Note4} | -D4 -D5 ^{Note5} |

Notes: 1. The muffler thread for direct piping is M3X0.5 and the muffler cannot be used for sub-base piping.
2. When ordering the sub-base piping with muffler, always enter both -25 (sub-base) and -75 (muffler). The muffler thread for sub-base piping is M5X0.8 and the muffler cannot be used for direct piping.
3. The locking-type manual override is not available in the quick response type EB10S.

4. The grommet type is not available in the low current type EB10L and quick response type EB10S.
5. The DC12V specification is not available in the low current type EB10L and quick response type EB10S.

EB Series Manifold Order Codes

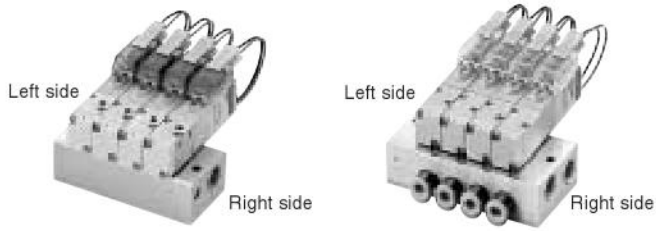

Manifold specification

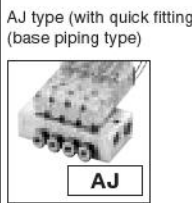
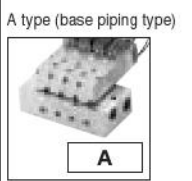
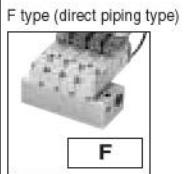

Model

- EB10**
Standard type
- EB10L**
Low current type
- EB10S**
Quick response type

Valve specification

- F1, A1:** 2-port normally closed (NC)
- F2, A2:** 2-port normally open (NO)
- F3, A3:** 3-port normally closed (NC)
- F4, A4:** 3-port normally open (NO)

Manual Override

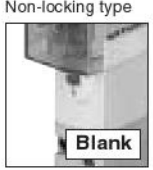

Wiring specification

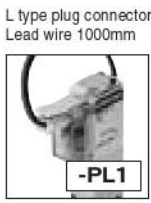
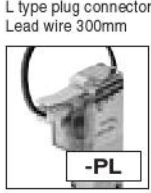
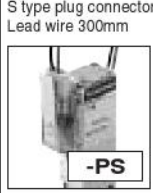

300mm = 11.8in.
1000mm = 39in.
3000mm = 118in.

Voltage

- D4**
DC24V
- D5**
DC12V^{Note4}

| Model | Number of units | Manifold specification | Station | Model | Valve specification | Manual override | Wiring specification | Voltage |
|-------|-----------------|------------------------|---------|-------|---------------------|-----------------|----------------------|---------|
|-------|-----------------|------------------------|---------|-------|---------------------|-----------------|----------------------|---------|

| Manifold model | | | Mounting valve model | | | | | | |
|--|-----|------------------------|------------------------------|---|------------------------|----------------------|-------------------------------|--|-----------------------------|
| F type manifold (direct piping type) | EBM | 2 · · · 20 | F | stn.1 · · · stn.□ <small>Note1</small> | EB10 EB10L EB10S | F1 F2 F3 F4 | Blank -81 ^{Note2} | -PS -PS1 -PS3 -PSN -PL -PL1 -PL3 -PLN -GL ^{Note3} | -D4 -D5 ^{Note4} |
| | | | EBBP-F (for block-off plate) | | | | | | |
| A, AJ type manifolds (base piping type) | EBM | 2 · · · 20 | A AJ | stn.1 · · · stn.□ <small>Note1</small> | EB10 EB10L EB10S | A1 A2 A3 A4 | Blank -81 ^{Note2} | -PS -PS1 -PS3 -PSN -PL -PL1 -PL3 -PLN -GL ^{Note3} | -D4 -D5 ^{Note4} |
| | | | EBBP-A (for block-off plate) | | | | | | |

Notes: 1. The valve mounting location is from the left side of the manifold.
 2. The locking-type manual override is not available in the quick response type **EB10S**.
 3. The grommet type is not available in the low current type **EB10L** and quick response type **EB10S**.
 4. The DC12V specification is not available in the low current type **EB10L** and quick response type **EB10S**.

SOLENOID VALVES EA, EB SERIES

EB Series Additional Parts Order Codes

Block-off plate (block-off plate, gasket, and 2 mounting screws)

EBBP -

Specification

- F : For F type manifold
- A : For A, AJ type manifolds

Connector-related

EAZ -

Connector specification

- P : Connector, lead wire length 300mm [11.8in.]
- P1 : Connector, lead wire length 1000mm [39in.]
- P3 : Connector, lead wire length 3000mm [118in.]
- PN : Connector, without lead wire (contacts included)

Common connector assembly

EAZ -

Connector specification

- PA : Positive common A type, connector, lead wire length 300mm [11.8in.]
- PA1 : Positive common A type, connector, lead wire length 1000mm [39in.]
- PA3 : Positive common A type, connector, lead wire length 3000mm [118in.]
- PB : Positive common B type, connector, lead wire length 300mm [11.8in.]
- PB1 : Positive common B type, connector, lead wire length 1000mm [39in.]
- PB3 : Positive common B type, connector, lead wire length 3000mm [118in.]
- PC : Positive common C type, connector, lead wire length 300mm [11.8in.]
- PC1 : Positive common C type, connector, lead wire length 1000mm [39in.]
- PC3 : Positive common C type, connector, lead wire length 3000mm [118in.]
- CPN : Positive common, connector, without lead wire (short bar and contacts included)

A type: EAZ-PA□*



B type: EAZ-PB□*

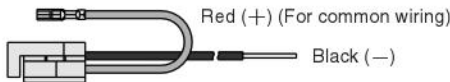

C type: EAZ-PC□*

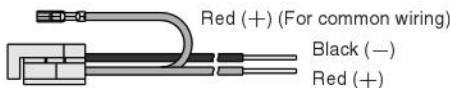

- *Lead wire length
- Blank : 300mm [11.8in.]
 - 1 : 1000mm [39in.]
 - 3 : 3000mm [118in.]

Application example

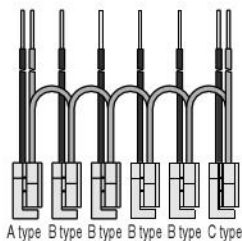

Dimensions of EB Series Single Valve Unit (mm)

2, 3-port, single solenoid

- EB10□ F1-PL
- EB10□ F2-PL
- EB10□ F3-PL
- EB10□ F4-PL

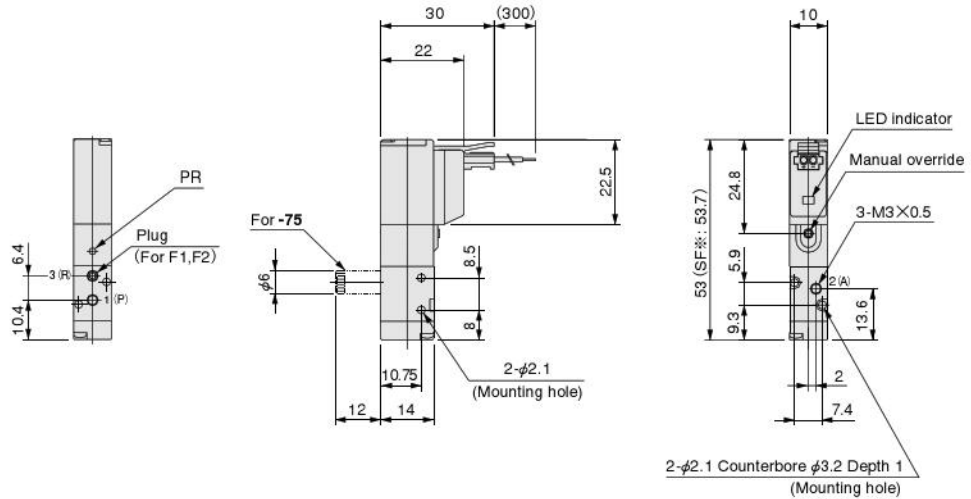

2, 3-port, single solenoid (with sub-base)

- EB10□ A1-25-PL
- EB10□ A2-25-PL
- EB10□ A3-25-PL
- EB10□ A4-25-PL

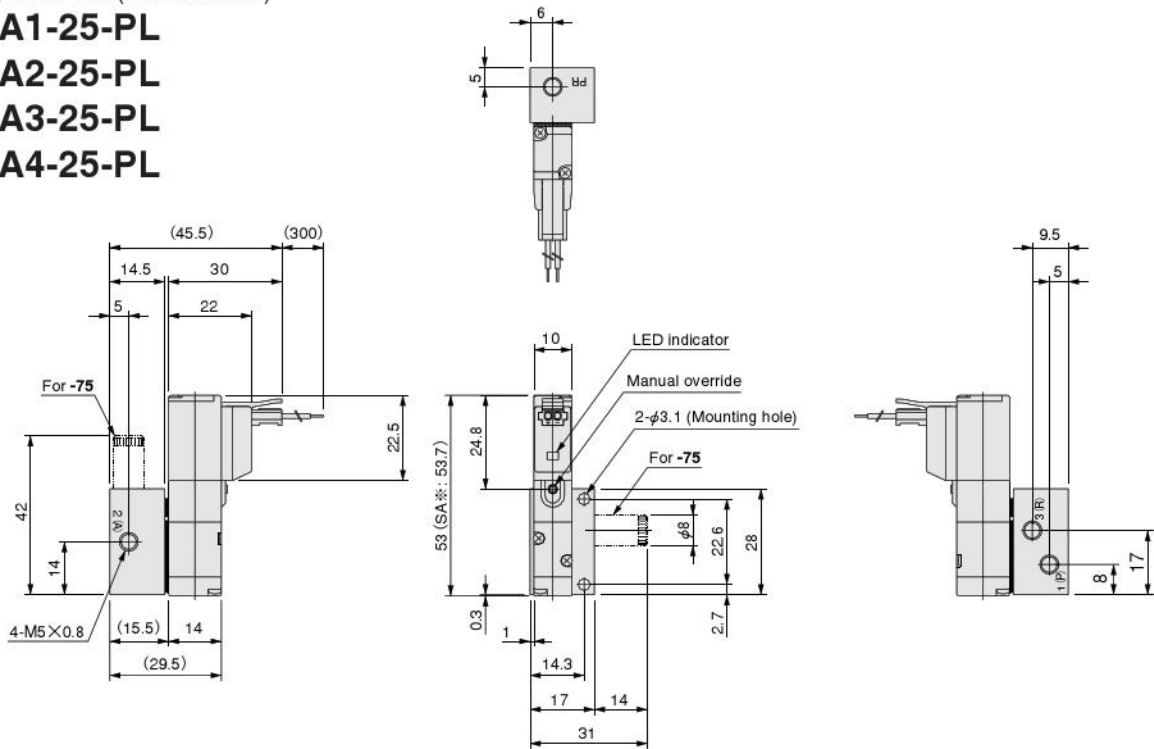

Options

● Mounting base: -21

● Locking type manual override: -81

● Grommet: -GL

● S type plug connector: -PS

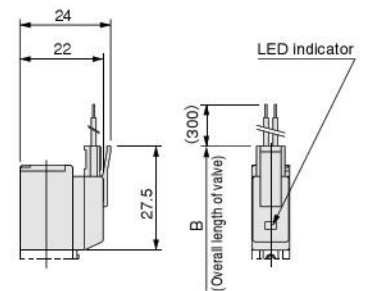
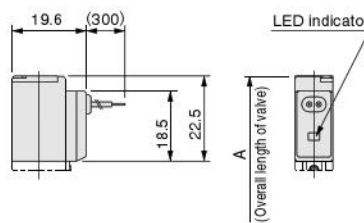
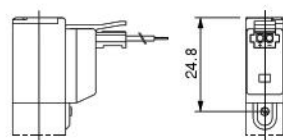
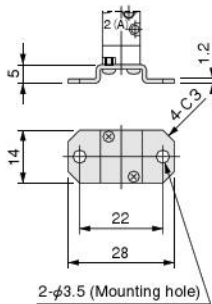

| Model | Code | A | B | Remark |
|----------------------------------|------|----|------|--|
| EB10F1~EB10F4, EB10A1~EB10A4 | | 53 | 58 | Overall length to the end of the valve |
| EB10LF1~EB10LF4, EB10LA1~EB10LA4 | | — | 58 | |
| EB10SF1~EB10SF4, EB10SA1~EB10SA4 | | — | 58.7 | |

Dimensions of EB Series Manifold (mm)

For 2, 3-port

EBM□F (Direct piping type)

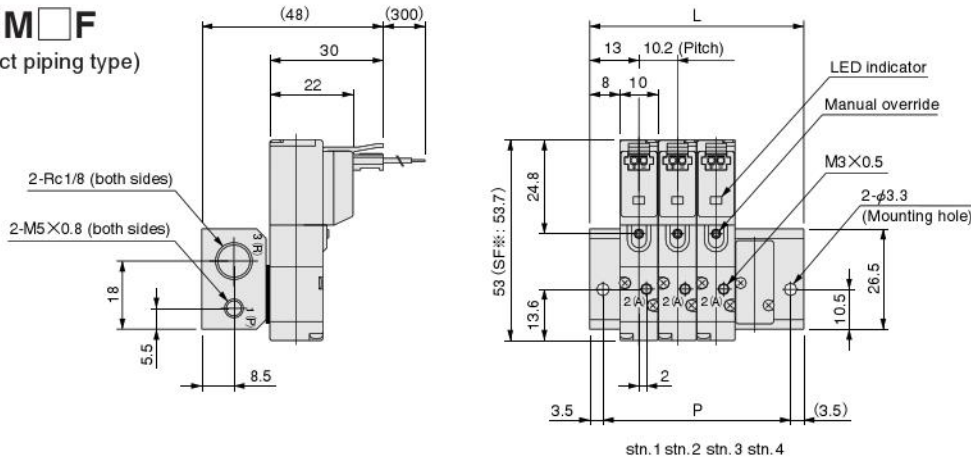

[Installation example]

- EBM4F**
 stn.1 EB10F1-PL-D4
 stn.2 EB10F3-PL-D4
 stn.3 EB10F4-PL-D4
 stn.4 EBBP-F

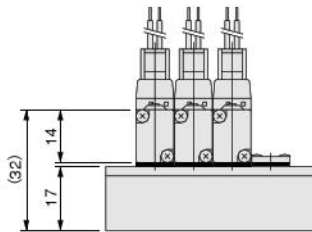

Unit dimensions

| Number of units | L | P |
|-----------------|-------|-------|
| 2 | 36.2 | 29.2 |
| 3 | 46.4 | 39.4 |
| 4 | 56.6 | 49.6 |
| 5 | 66.8 | 59.8 |
| 6 | 77.0 | 70.0 |
| 7 | 87.2 | 80.2 |
| 8 | 97.4 | 90.4 |
| 9 | 107.6 | 100.6 |
| 10 | 117.8 | 110.8 |
| 11 | 128.0 | 121.0 |
| 12 | 138.2 | 131.2 |
| 13 | 148.4 | 141.4 |
| 14 | 158.6 | 151.6 |
| 15 | 168.8 | 161.8 |
| 16 | 179.0 | 172.0 |
| 17 | 189.2 | 182.2 |
| 18 | 199.4 | 192.4 |
| 19 | 209.6 | 202.6 |
| 20 | 219.8 | 212.8 |

EBM□A (Base piping type)

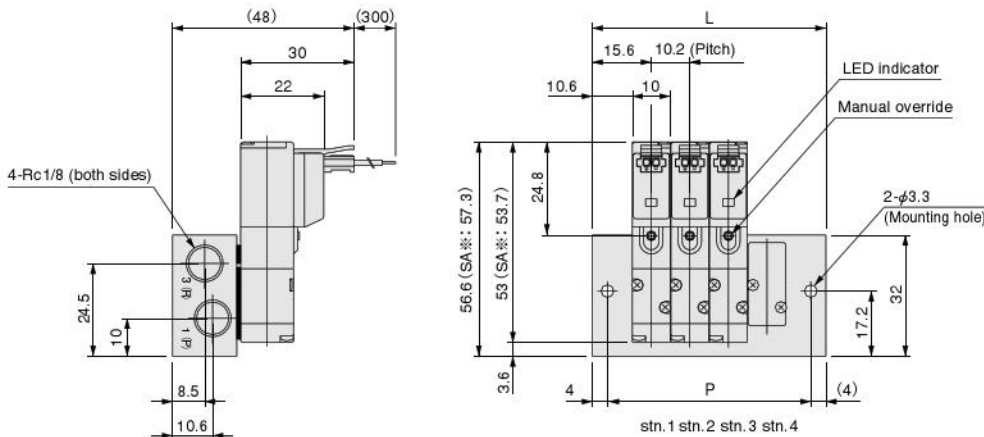

[Installation example]

- EBM4A**
 stn.1 EB10A1-PL-D4
 stn.2 EB10A3-PL-D4
 stn.3 EB10A4-PL-D4
 stn.4 EBBP-A

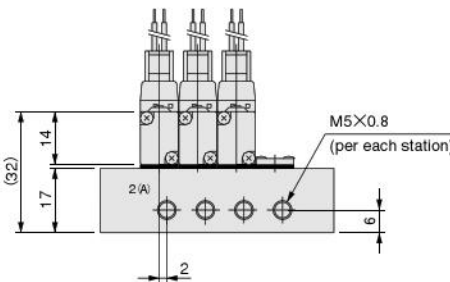

Unit dimensions

| Number of units | L | P |
|-----------------|-------|-------|
| 2 | 41.4 | 33.4 |
| 3 | 51.6 | 43.6 |
| 4 | 61.8 | 53.8 |
| 5 | 72.0 | 64.0 |
| 6 | 82.2 | 74.2 |
| 7 | 92.4 | 84.4 |
| 8 | 102.6 | 94.6 |
| 9 | 112.8 | 104.8 |
| 10 | 123.0 | 115.0 |
| 11 | 133.2 | 125.2 |
| 12 | 143.4 | 135.4 |
| 13 | 153.6 | 145.6 |
| 14 | 163.8 | 155.8 |
| 15 | 174.0 | 166.0 |
| 16 | 184.2 | 176.2 |
| 17 | 194.4 | 186.4 |
| 18 | 204.6 | 196.6 |
| 19 | 214.8 | 206.8 |
| 20 | 225.0 | 217.0 |

Dimensions of EB Series Manifold (mm)

For 2, 3-port

EBM□AJ

(Base piping type with quick fittings)

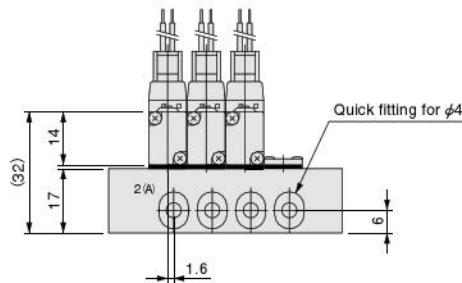
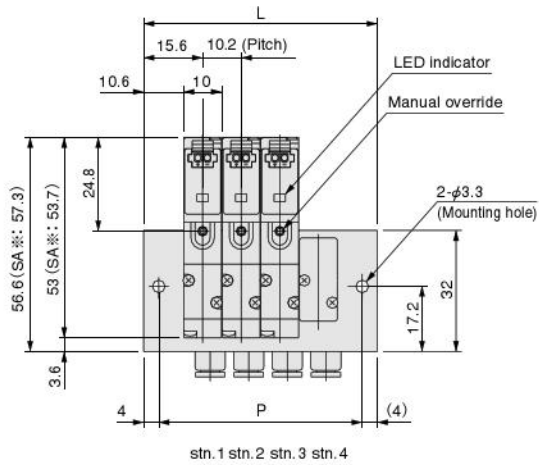
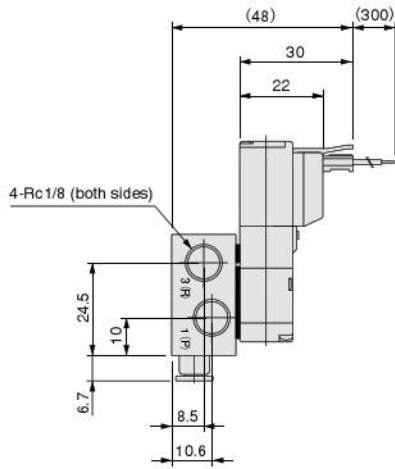

[Installation example]

EBM4AJ

- stn.1 EB10A1-PL-D4
- stn.2 EB10A3-PL-D4
- stn.3 EB10A4-PL-D4
- stn.4 EBBP-A

Unit dimensions

| Number of units | L | P |
|-----------------|-------|-------|
| 2 | 41.4 | 33.4 |
| 3 | 51.6 | 43.6 |
| 4 | 61.8 | 53.8 |
| 5 | 72.0 | 64.0 |
| 6 | 82.2 | 74.2 |
| 7 | 92.4 | 84.4 |
| 8 | 102.6 | 94.6 |
| 9 | 112.8 | 104.8 |
| 10 | 123.0 | 115.0 |
| 11 | 133.2 | 125.2 |
| 12 | 143.4 | 135.4 |
| 13 | 153.6 | 145.6 |
| 14 | 163.8 | 155.8 |
| 15 | 174.0 | 166.0 |
| 16 | 184.2 | 176.2 |
| 17 | 194.4 | 186.4 |
| 18 | 204.6 | 196.6 |
| 19 | 214.8 | 206.8 |
| 20 | 225.0 | 217.0 |

SOLENOID VALVES EA, EB SERIES