

Small, easy-to-use, simple construction valves!
 Suitable for various needs and offering high-performance control, while achieving still lower power consumption and quicker response!

New Standard Valve SOLENOID VALVES EA, EB SERIES

SOLENOID VALVES EA series

(2, 3, 5-port pilot type solenoid valves)

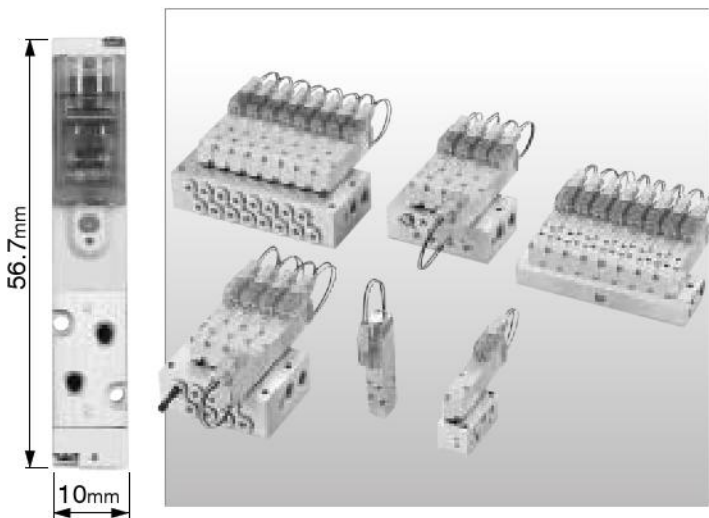

Provides reliable performance for all situations in which solenoid valves are required, in the manufacturing lines, in machinery, or in equipment.
 A NEW standard in compact valves!

● **Space Saving—Thin and compact size**

Valve width: 10mm [0.394in.]
 Valve length: 56.7mm [2.232in.] (EA series)
 53mm [2.087in.] (EB series)
 (for standard type)

● **Flow—Efficient flow rate**

Sonic conductance C: 0.26dm³/(s·bar)
 (Effective area: 1.3mm² [Cv: 0.07])
 Optimum for pilot-operated valves, and for operating up to ϕ 25 [0.984in.] bore size cylinders.

● **Response—Fast response time**

Response time: When ON, 6ms or below
 When OFF, 7ms or below
 (in the case of quick response type single solenoids)

● **Power—Lower power consumption**

Standard type: 0.55W, Low current type: 0.15W

● **Reliability—Improved reliability**

New solenoid and stem construction resulting from years of our valve technology experience have boosted operating life, response, and other basic performance features.

● **Environmental Protection—Improved performance**

Grommet type valves offer moisture proof specifications.

SOLENOID VALVES EB series

(2, 3-port pilot type solenoid valves)

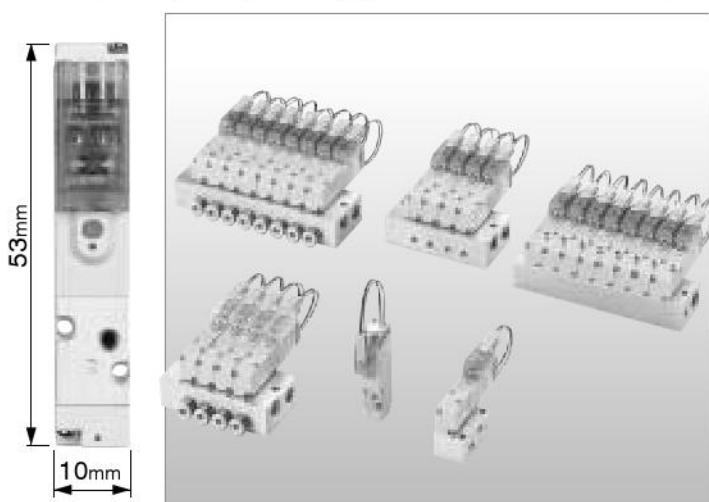

—Product Variety—
Providing a wide product range

Solenoid Valves EA Series

Single solenoid Double solenoid

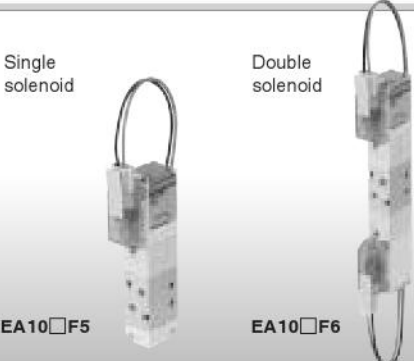

EA10□F5 EA10□F6 116

Solenoid Valves EB Series (2, 3-port valves)

Normally closed (NC) Normally open (NO)



EB10□F1 EB10□F2
 EB10□F3 EB10□F4 128

Single unit (base piping)

Single solenoid Double solenoid



EA10□A5-25 EA10□A6-25 116

Normally closed (NC) Normally open (NO)

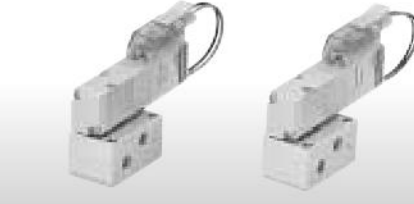

EB10□A1-25 EB10□A2-25
 EB10□A3-25 EB10□A4-25 128

F type manifold (direct piping type)

Manifold for combination mounting of 2, 3, 5-port valves

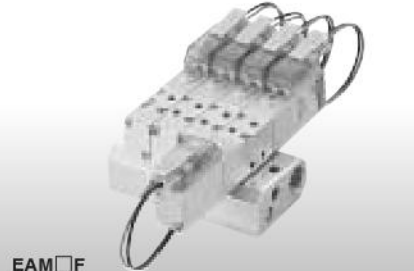

EAM□F 118

Manifold for 2, 3-port valves



EBM□F 129

A, AJ type manifolds (base piping type)

Manifold for combination mounting of 2, 3, 5-port valves

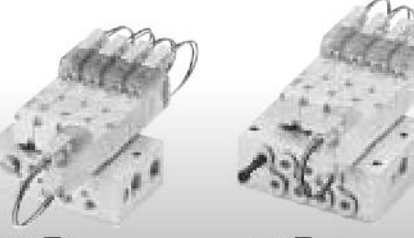

EAM□A EAM□AJ 118

Manifold for 2, 3-port valves

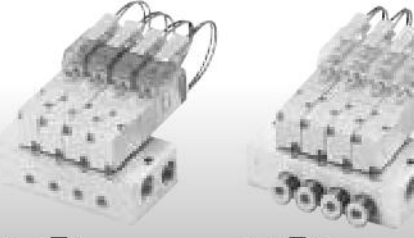

EBM□A EBM□AJ 129

Function-specific solenoids (for both EA and EB series)

- Standard, low current and quick response types can be identified by the color of their housings.

Standard type: Blue



Low current type: Light blue



Quick response type: White





Solenoid

Internal circuit

●DC12V, DC24V

(Standard type)

Solenoid with LED Indicator and surge suppression

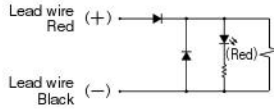

●DC24V

(Low current, quick response types)

Solenoid with LED Indicator and surge suppression

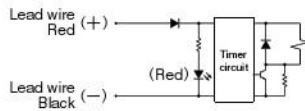

- Cautions:**
1. Do not apply megger between the pins.
 2. Leakage current inside the circuit could result in failure of the solenoid valve to return to the rest position or other erratic operation. Always use it at less than the allowable leakage current shown in the solenoid specifications on p.109 and 121. If circuit conditions, etc. cause the leakage current to exceed the maximum allowable leakage current, consult us.
 3. For the double solenoid configuration, avoid energizing both solenoids simultaneously.
 4. The standard housing type is colored blue, while the low current type is light blue, and the quick response type is white.
 5. The low current and quick response types will not activate when the power supply voltage is raised too slowly. Always apply the appropriate voltage.

Operating principles of low current and quick response types

The low current and quick response types use a timer circuit, as shown above, that achieves power savings by switching to the holding operations mode after a certain period of time and operates at about 1/3 of the starting power consumption.

●Power waveform for low current type

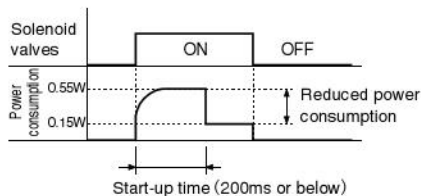

●Power waveform for quick response type

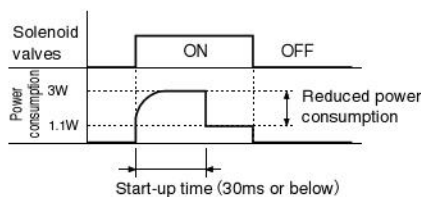

Plug connector

Attaching and removing plug connector

Use fingers to insert the connector into the pin, push it in until the lever claw latches onto the protruded section of the connector housing, and complete the connection.

To remove the connector, squeeze the lever along with the connector, lift the lever claw up from the protruded section of the connector housing, and pull it out.

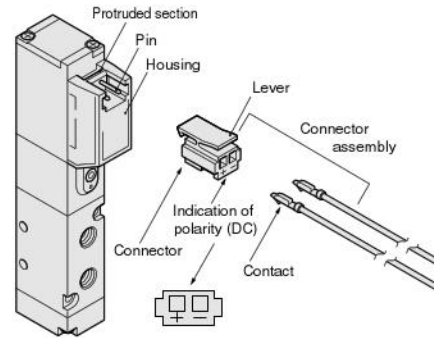

Crimping of connecting lead wire and contact

To crimp lead wires into contacts, strip off 4mm [0.16in.] of the insulation from the end of the lead wire, insert it into the contact, and crimp it. Be sure at this time to avoid catching the insulation on the exposed wire crimping section.

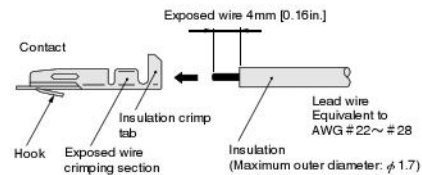

- Cautions:**
1. Do not pull hard on the lead wire.
 2. Always use a dedicated tool for crimping of connecting lead wire and contact.
Contact: Model 702062-2M
Manufactured by Sumiko Tech, Inc.
Crimping tool: Model F1-702062
Manufactured by Sumiko Tech, Inc.

Attaching and removing contact and connector

Insert the contact with lead wire into a plug connector hole until the contact hook latches on and is secured to the plug connector. Confirm that the lead wire cannot be easily pulled out.

To remove it, insert a tool with a fine tip (such as a small screwdriver) into the rectangular hole on the side of the plug connector to push up on the hook, and then pull out the lead wire.

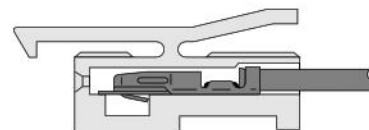

- Cautions:**
1. Do not pull hard on the lead wire. It could result in defective contacts, breaking wires, etc.
 2. If the pin is bent, use a small screwdriver, etc. to gently straighten out the pin, and then complete the connection to the plug connector.



Manual override

Non-locking type

To operate the manual override, press it all the way down. For the single solenoid, the valve works the same as when in the energized state as long as the manual override is pushed down, and returns to the rest position upon release. For the double solenoid, pressing the manual override on the 14 (SA) side switches the 14 (SA) to the energized state, and the unit remains in that state even after the manual override is released. To return it to the rest position, operate the manual override on the 12 (SB) side. This is the same for the solenoid 12 (SB).

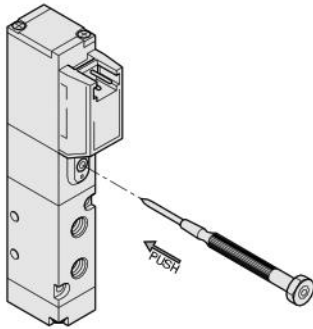

Locking type

To lock the manual override, use a small screwdriver to push down on the manual override all the way down and turn it clockwise 45 degrees. When locked, turning the manual override 45 degrees in the counterclockwise direction returns it to its original position, and releases the lock. (Excluding the quick response type)

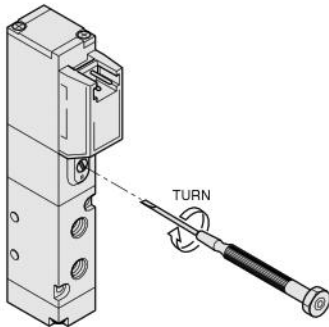

- Cautions:**
1. The EA, EB series valves are pilot type solenoid valves. As a result, the manual override cannot switch the main valve without air supplied from the 1(P) port.
 2. Always release the lock of the locking type manual override before commencing normal operation.
 3. Do not attempt to operate the manual override with a pin or other object having an extremely fine tip. It could result in damage to the manual override.

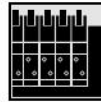

Manifold

Mounting valves on manifold

When mounting valves on manifold, the recommended tightening torque for the valve mounting screw is 14.7N·cm {1.5kgf·cm} [1.3lbf·in.].

Tube

1. Attaching and removing tubes

For tube connection, insert an appropriate size tube until it makes contact with the tube stopper, and lightly pull it to check the connection.

For tube removal, push the tube against the tube stopper, then push the release ring and at the same time pull the tube out.

2. Either a nylon or urethane tube can be used.

Use tubes with an outer diameter tolerance within $\pm 0.1\text{mm}$ [0.004in.] of the nominal diameter, and ensure the ovalness (difference between the large diameter and small diameter) is 0.2mm [0.008in.] or less.

(Using a Koganei tube is recommended.)

- Cautions:**
1. Do not use extra-soft tubes since their pull-out strength is significantly reduced.
 2. Only use tubes without scratches on their outer surfaces. If a scratch occurs during repeated use, cut off the scratched section.
 3. Do not bend the tube excessively near the fittings. The minimum bending radius is as shown in the table below.
 4. When attaching or removing tubes, always stop the air supply. In addition, always confirm that air has been completely exhausted from the manifold.

Tube size	Minimum bending radius	
	Nylon tube	Urethane tube
$\phi 3$	—	7 [0.28]
$\phi 4$	20 [0.79]	10 [0.39]
$\phi 6$	30 [1.18]	15 [0.59]
$\phi 8$	50 [1.97]	20 [0.79]

Solenoid Valves EA Series

SOLENOID VALVES EA, EB SERIES

EA

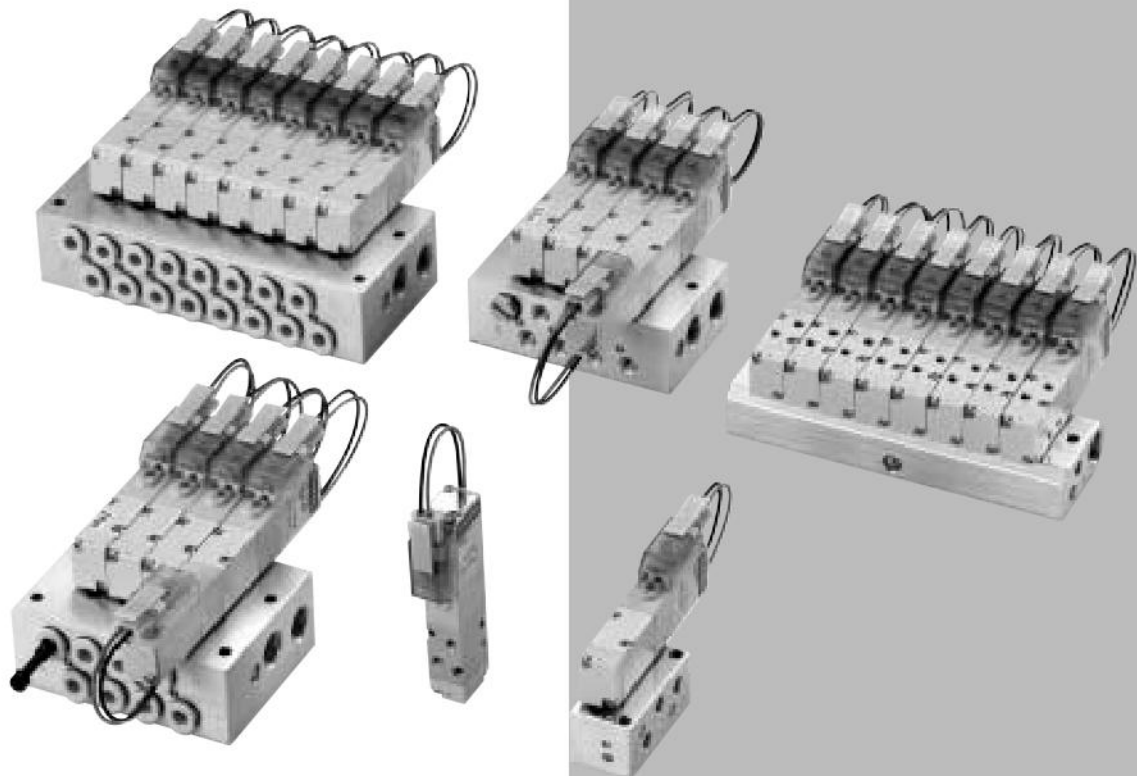

EA SERIES SPECIFICATIONS

Specifications

Basic Models and Functions

Basic model	For direct piping, F type manifold	EA10□F1 ^{Note} EA10□F2 ^{Note} EA10□F3 ^{Note} EA10□F4 ^{Note}	EA10□F5	EA10□F6
	For base piping, A, AJ type manifolds	EA10□A1 ^{Note} EA10□A2 ^{Note} EA10□A3 ^{Note} EA10□A4 ^{Note}	EA10□A5	EA10□A6
Item				
Number of positions		2 positions		
Number of ports		2, 3 ports	5 ports	
Valve function		Single solenoid NC, NO	Single solenoid	Double solenoid

Remark: For the optional specifications and order codes, see p.113

Note: Valves with valve specifications F1, F2, F3, F4, A1, A2, A3, and A4 are for mounting on manifolds only, and cannot be used as single valve units.

Specifications

Basic model	For direct piping, F type manifold	EA10□F1 EA10□F2 EA10□F3 EA10□F4	EA10□F5	EA10□F6
	For base piping, A, AJ type manifolds	EA10□A1 EA10□A2 EA10□A3 EA10□A4	EA10□A5	EA10□A6
Item				
Media		Air		
Operation type		Internal pilot type		
Flow rate characteristics ^{Note 1}	Sonic conductance C [dm ³ /(s·bar)]	Base piping (A, AJ type): 0.26		
	Effective area S [Cv] mm ²	Direct piping (F type): 1.3 [0.07]		
Port size ^{Note 2}		M3×0.5		
Lubrication		Not required		
Operating pressure range MPa [kgf/cm ²] [psi.]		0.2~0.7 [2~7.1] [29~102]		
Proof pressure MPa[kgf/cm ²] [psi.]		1.05 [10.7] [152]		
Response time ^{Note 3} ON/OFF ms	Standard type	10/20 or below	12 or below	
	Low current type (L)	10/50 or below	12 or below	
	Quick response type (S)	6/7 or below	6 or below	
Maximum operating frequency Hz	Standard type	5		
	Low current type (L)	2		
	Quick response type (S)	10		
Minimum time to energize for self holding ^{Note 4} ms		—	50	
Operating temperature range (atmosphere and media) °C [°F]		5~50 [41~122]		
Shock resistance m/s ² [G]		1373.0 [140] (Axial direction 294.2 [30])	1373.0 [140] (Axial direction 147.1 [15])	
Mounting direction		Any		

Notes: 1. For details, see the flow rate characteristics on p.110.

2. For details, see the port size on p.110.

3. Values when air pressure is 0.5MPa [73psi].

4. For double solenoid valves.

Solenoid Specifications

Item	Rated voltage		DC12V (Standard type)	DC24V (Standard type)	DC24V (Low current type)	DC24V (Quick response type)
	Operating voltage range	V		10.8~13.2 (12±10%)	21.6~26.4 (24±10%)	21.6~26.4 (24±10%)
Standard type	Current (when rated voltage is applied) mA (r.m.s)		46	23	—	—
	Power consumption W		0.55	0.55	—	—
Low current type Quick response type	Current (when rated voltage is applied)	Starting mA	—	—	23	125
		Holding mA	—	—	6.3	46
	Power consumption	Starting W	—	—	0.55	3
		Holding W	—	—	0.15	1.1
	Start-up time (standard time) ms		—	—	200 or below	30 or below
	Allowable leakage current mA		2	1	0.5	4
Insulation resistance MΩ		Over 100 (value at DC500V megger)				
Color of LED indicator		Red				
Surge suppression (as standard)		Flywheel diode				

Port Size

Specification	Port	2(B), 4(A)	1(P)	3, 5(R)	PR
Single unit	Direct piping	M3×0.5	M3×0.5	M3×0.5	—
	Base piping (with sub-base)	M5×0.8	M5×0.8	M5×0.8	M5×0.8
Manifold	F type	M3×0.5	M5×0.8	Rc1/8	Collected at 3, 5 (R) port
	A type	M5×0.8	Rc1/8	Rc1/8	
	AJ type	Quick fitting for $\phi 4$	Rc1/8	Rc1/8	

Flow Rate Characteristics

The test method for flow rate characteristics conforms to JIS B 8390:2000 (test method for pneumatic equipment — equipment for compressible fluids — flow rate characteristics).

● When used as a single unit

Basic model		Flow path	Sonic conductance C dm ³ /(s·bar)	Critical pressure ratio b	Effective area S [Cv] mm ²	
Direct piping	EA10□F5 EA10□F6	1 (P) → 4 (A)	—	—	1.30 (0.072)	0.75 (0.042) <small>Note1</small> (with fittings)
		1 (P) → 2 (B)	—	—		
		4 (A) → 5 (R1)	—	—		
		2 (B) → 3 (R2)	—	—		
Base piping (with sub-base)	EA10□A5 EA10□A6	1 (P) → 4 (A)	0.26	0.17	1.30 (0.072) <small>Note3</small>	
		1 (P) → 2 (B)	0.22	0.00	1.10 (0.061) <small>Note3</small>	
		4 (A) → 5 (R1)	0.26	0.17	1.30 (0.072) <small>Note3</small>	
		2 (B) → 3 (R2)	0.26	0.12	1.30 (0.072) <small>Note3</small>	

● When mounted on a manifold

Basic model		Flow path	Sonic conductance C dm ³ /(s·bar)	Critical pressure ratio b	Effective area S [Cv] mm ²	
F type manifold (direct piping type)	EA10□F1 EA10□F2 EA10□F3 EA10□F4 EA10□F5 EA10□F6	1 (P) → 4 (A)	—	—	1.30 (0.072)	0.80 (0.044) <small>Note2</small> (with fittings)
		1 (P) → 2 (B)	—	—		
		4 (A) → 5 (R1)	—	—		
		2 (B) → 3 (R2)	—	—		
		1 (P) → 4 (A)	0.26	0.12		
A, AJ type manifolds (base piping type)	EA10□A1 EA10□A2 EA10□A3 EA10□A4 EA10□A5 EA10□A6	1 (P) → 2 (B)	0.26	0.18	1.30 (0.072) <small>Note3</small>	
		4 (A) → 5 (R1)	0.25	0.26	1.25 (0.069) <small>Note3</small>	
		2 (B) → 3 (R2)	0.26	0.20	1.30 (0.072) <small>Note3</small>	

- Notes: 1. Quick fitting TS3-M3Ms have been mounted on connection ports 1(P), 2(B), and 4(A).
 2. Quick fitting TS3-M3Ms have been mounted on connection ports 2(B), and 4(A).
 3. Figures in effective area S are calculated based on sonic conductance C ($S=5.0 \times C$).

Base piping type
(Effective area S = 1.3mm² [Cv: 0.072])

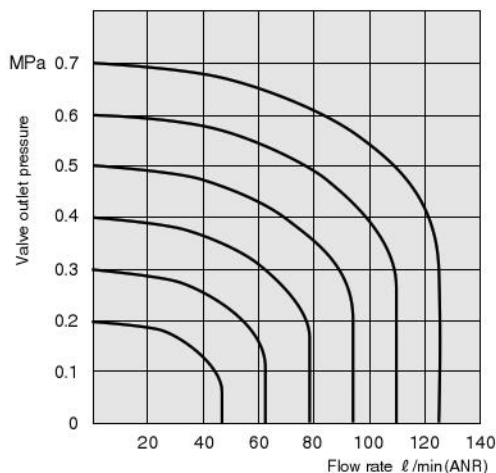

Direct piping type with fittings
(Effective area S = 0.75mm² [Cv: 0.042])

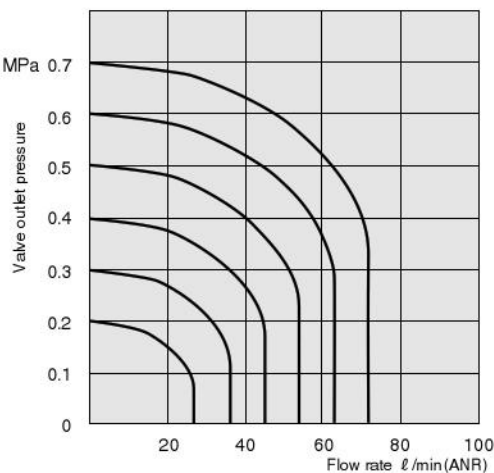

- Graphs use flow rate calculations based on the discharge method.
- Use the flow rate as a guide.

1MPa = 145psi., 1 l / min = 0.0353ft.³/min.

Mass

Single Valve Unit Mass

g [oz.]

Basic model	Mass	Additional mass	
		-21 (with bottom mounting base)	-25 (with sub-base)
EA10□F1	23 [0.81]	—	—
EA10□F2	23 [0.81]		
EA10□F3	23 [0.81]		
EA10□F4	23 [0.81]		
EA10□F5	23 [0.81]		
EA10□F6	38 [1.34]		
EA10□A1	23 [0.81]	—	—
EA10□A2	23 [0.81]		
EA10□A3	23 [0.81]		
EA10□A4	23 [0.81]		
EA10□A5	23 [0.81]	—	23 [0.81]
EA10□A6	38 [1.34]		

Manifold Mass

g [oz.]

Basic model	Mass calculation of each unit (n=number of units)	Block-off plate
EAM□F	$(9 \times n) + 15$ [(0.32 × n) + 0.53]	3 [0.11]
EAM□A	$(18 \times n) + 38$ [(0.63 × n) + 1.34]	4 [0.14]
EAM□AJ	$(27.5 \times n) + 50$ [(0.97 × n) + 1.76]	4 [0.14]

Calculation example: **EAM8AJ**

stn.1~8 EA10A5-PS-D4

$$(27.5 \times 8) + 50 + (23 \times 8) = 454g [16.01oz.]$$

5-port, 2-position

Single solenoid

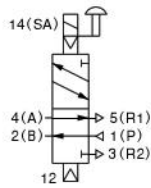

Double solenoid

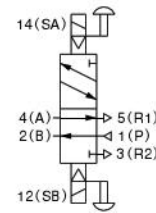

EA10F5
De-energized

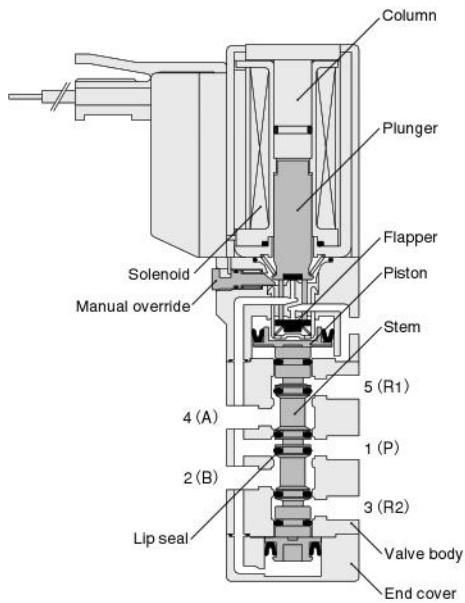

EA10F6
De-energized condition after energizing solenoid 12(SB)

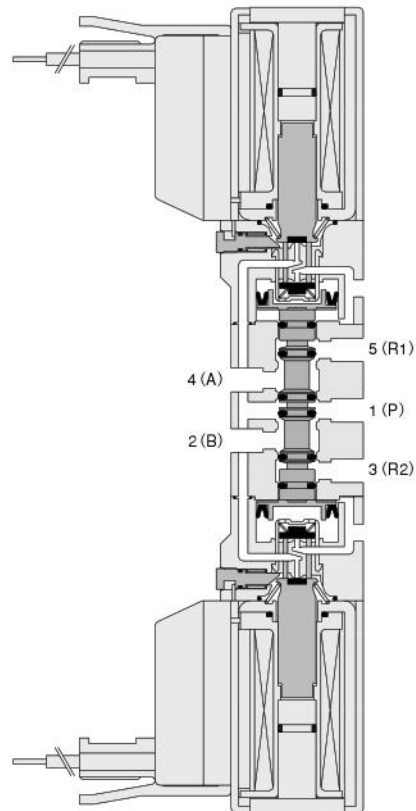

Major Parts and Materials

Parts	Materials	
Body	Aluminum alloy	
Stem	(anodized)	
Lip seal	Synthetic rubber	
Flapper		
Valve	Mounting base	Mild steel (zinc plated)
	Sub-base	Aluminum alloy (anodized)
	Plunger	Magnetic stainless steel
	Column	steel
	End cover	Plastic
Manifold	Body	Aluminum alloy (anodized)
	Block-off plate	Mild steel (nickel plated)
	Seal	Synthetic rubber

EA Series Single Valve Unit Order Codes



Model

EA10

Standard type

EA10L

Low current type

EA10S

Quick response type

Valve specification

F1, A1: 2-port normally closed (NC)^{Note1}

F2, A2: 2-port normally open (NO)^{Note1}

F3, A3: 3-port normally closed (NC)^{Note1}

F4, A4: 3-port normally open (NO)^{Note1}

F5, A5: 5-port 2-position, single solenoid

F6, A6: 5-port 2-position, double solenoid

Mounting base

Without mounting base

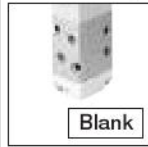

With mounting base

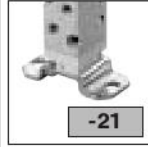

Sub-base

Without sub-base

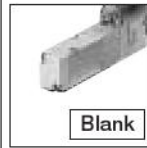

With sub-base



Muffler

Without muffler

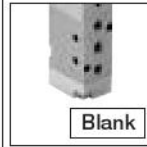

With muffler for direct piping^{Note2}

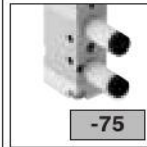

With muffler for sub-base piping^{Note3}



Manual override

Non-locking type

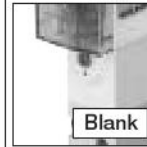

Locking type^{Note4}

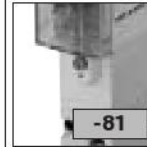

Wiring specification

S type plug connector
Lead wire 300mm

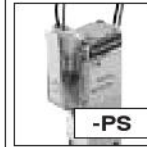

L type plug connector
Lead wire 300mm

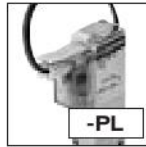

S type plug connector
Lead wire 1000mm

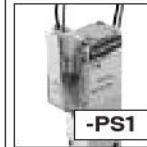

L type plug connector
Lead wire 1000mm

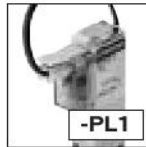

S type plug connector
Lead wire 3000mm

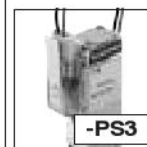

L type plug connector
Lead wire 3000mm

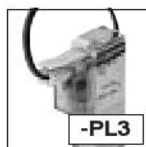

S type plug connector
Without connector ass'y

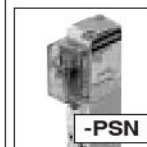

L type plug connector
Without connector ass'y

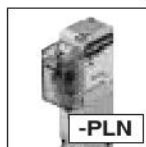

Grommet type^{Note5}
Lead wire 300mm
(moisture proof specification)



Voltage

-D4

DC24V

-D5

DC12V^{Note6}

300mm = 11.8in.
1000mm = 39in.
3000mm = 118in.

	Model	Valve specification	Mounting base	Sub-base	Muffler	Manual override	Wiring specification	Voltage
Direct piping	EA10 EA10L EA10S	F1 ^{Note1} F2 ^{Note1} F3 ^{Note1} F4 ^{Note1}	Blank -21		Blank -75 ^{Note2}	Blank -81 ^{Note4}	-PS -PS1 -PS3 -PSN -PL -PL1 -PL3 -PLN -GL ^{Note5}	-D4 -D5 ^{Note6}
		F5						
		F6						
Base piping	EA10 EA10L EA10S	A1 ^{Note1} A2 ^{Note1} A3 ^{Note1} A4 ^{Note1}		Blank -25	Blank -75 ^{Note3}	Blank -81 ^{Note4}	-PS -PS1 -PS3 -PSN -PL -PL1 -PL3 -PLN -GL ^{Note5}	-D4 -D5 ^{Note6}
		A5 A6						

Notes: 1. Valves with valve specifications F1, F2, F3, F4, A1, A2, A3, and A4 are for mounting on manifolds only, and cannot be used as single valve units.

2. The muffler thread for direct piping is M3X0.5 and the muffler cannot be used for sub-base piping.

3. When ordering the sub-base piping with muffler, always enter both -25 (sub-base) and -75 (muffler). The muffler thread for sub-base piping is M5X0.8 and the muffler cannot be used for direct piping.

4. The locking-type manual override is not available in the quick response type EA10S.

5. The grommet type is not available in the low current type EA10L and quick response type EA10S.

6. The DC12V specification is not available in the low current type EA10L and quick response type EA10S.

EA Series Manifold Order Codes

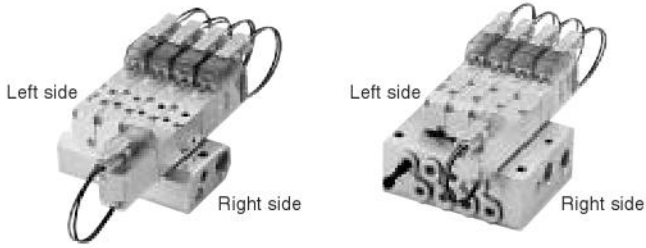

Manifold specification

F type (direct piping type)

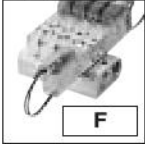

F

A type (base piping type)

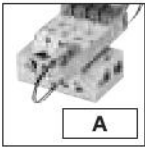

A

AJ type (with quick fittings)
(base piping type)

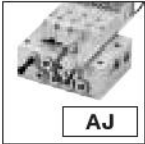

AJ

Model

EA10

Standard type

EA10L

Low current type

EA10S

Quick response type

Valve specification

F1, A1: 2-port normally closed (NC)

F2, A2: 2-port normally open (NO)

F3, A3: 3-port normally closed (NC)

F4, A4: 3-port normally open (NO)

F5, A5: 5-port 2-position, single solenoid

F6, A6: 5-port 2-position, double solenoid

Manual override

Non-locking type

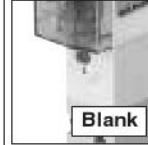

Blank

Locking type^{Note2}

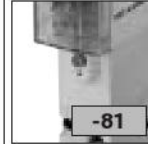

-81

Wiring specification

S type plug connector

Lead wire 300mm

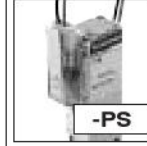

-PS

L type plug connector

Lead wire 300mm

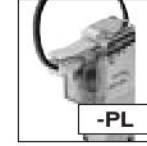

-PL

S type plug connector

Lead wire 1000mm



-PS1

L type plug connector

Lead wire 1000mm



-PL1

S type plug connector

Lead wire 3000mm

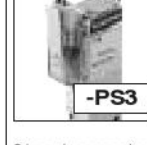

-PS3

L type plug connector

Lead wire 3000mm



-PL3

S type plug connector

Without connector ass'y



-PSN

L type plug connector

Without connector ass'y

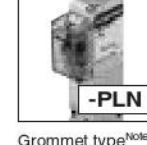

-PLN

Grommet type^{Note3}

Lead wire 300mm

(moisture proof specification)

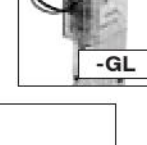

-GL

300mm = 11.8in.
1000mm = 39in.
3000mm = 118in.

Voltage

-D4

DC24V

-D5

DC12V^{Note4}

Model	Number of units	Manifold Specification	Station	Model	Valve specification	Manual override	Wiring specification	Voltage
-------	-----------------	------------------------	---------	-------	---------------------	-----------------	----------------------	---------

Manifold model				Mounting valve model				
F type manifold (direct piping type)	2 · · · 20	F	stn.1 · · · stn.□ <small>Note1</small>	EA10 EA10L EA10S	F1 F2 F3 F4 F5 F6	Blank -81 ^{Note2}	-PS -PS1 -PS3 -PSN -PL -PL1 -PL3 -PLN -GL ^{Note3}	-D4 -D5 ^{Note4}
			EABP-F (for block-off plate)					
A, AJ type manifolds (base piping type)	20	A AJ	stn.1 · · · stn.□ <small>Note1</small>	EA10 EA10L EA10S	A1 A2 A3 A4 A5 A6	Blank -81 ^{Note2}	-PS -PS1 -PS3 -PSN -PL -PL1 -PL3 -PLN -GL ^{Note3}	-D4 -D5 ^{Note4}
			EABP-A (for block-off plate)					

Notes: 1. The valve mounting location is from the left side of the manifold.
2. The locking-type manual override is not available in the quick response type EA10S.
3. The grommet type is not available in the low current type EA10L and quick response type EA10S.
4. The DC12V specification is not available in the low current type EA10L and quick response type EA10S.

SOLENOID VALVES EA, EB SERIES

EA Series Additional Parts Order Codes

Block-off plate (block-off plate, gasket, and 2 mounting screws)

EABP -

Specification

- F : For F type manifold
- A : For A, AJ type manifolds

Connector-related

EAZ -

Connector specification

- P : Connector, lead wire length 300mm [11.8in.]
- P1 : Connector, lead wire length 1000mm [39in.]
- P3 : Connector, lead wire length 3000mm [118in.]
- PN : Connector, without lead wire (contacts included)

Common connector assembly

EAZ -

Connector specification

- PA : Positive common A type, connector, lead wire length 300mm [11.8in.]
- PA1 : Positive common A type, connector, lead wire length 1000mm [39in.]
- PA3 : Positive common A type, connector, lead wire length 3000mm [118in.]
- PB : Positive common B type, connector, lead wire length 300mm [11.8in.]
- PB1 : Positive common B type, connector, lead wire length 1000mm [39in.]
- PB3 : Positive common B type, connector, lead wire length 3000mm [118in.]
- PC : Positive common C type, connector, lead wire length 300mm [11.8in.]
- PC1 : Positive common C type, connector, lead wire length 1000mm [39in.]
- PC3 : Positive common C type, connector, lead wire length 3000mm [118in.]
- CPN : Positive common, connector, without lead wire (short bar and contacts included)

A type: EAZ-PA*



B type: EAZ-PB*

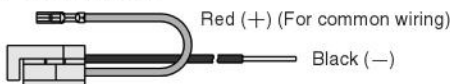

C type: EAZ-PC*

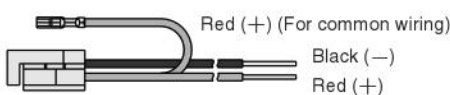

- *Lead wire length **Blank** : 300mm [11.8in.]
 1 : 1000mm [39in.]
 3 : 3000mm [118in.]

Application example

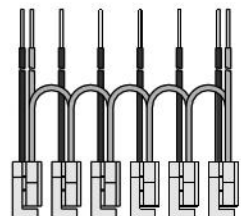

Dimensions of EA Series Single Valve Unit (mm)

5-port, single solenoid
EA10□F5-PL

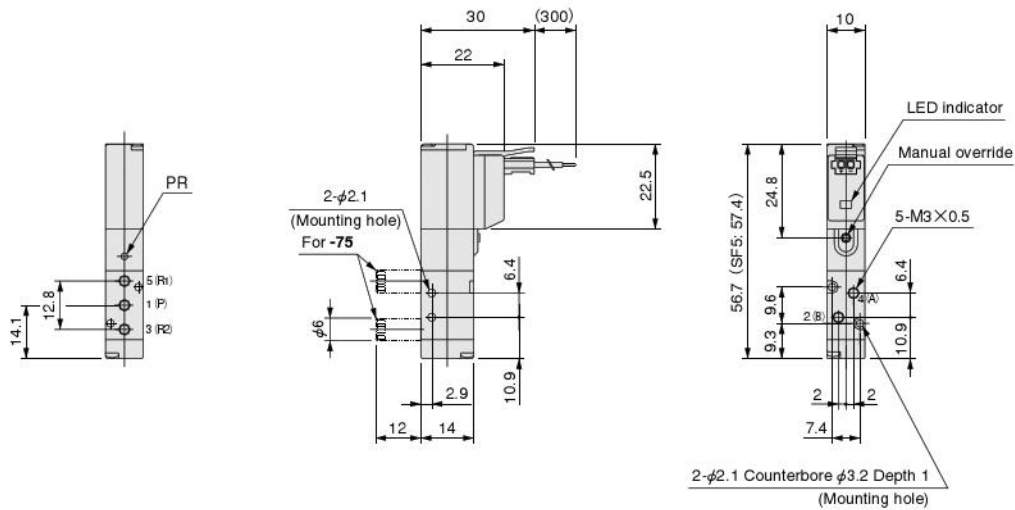

5-port, single solenoid (with sub-base)
EA10□A5-25-PL

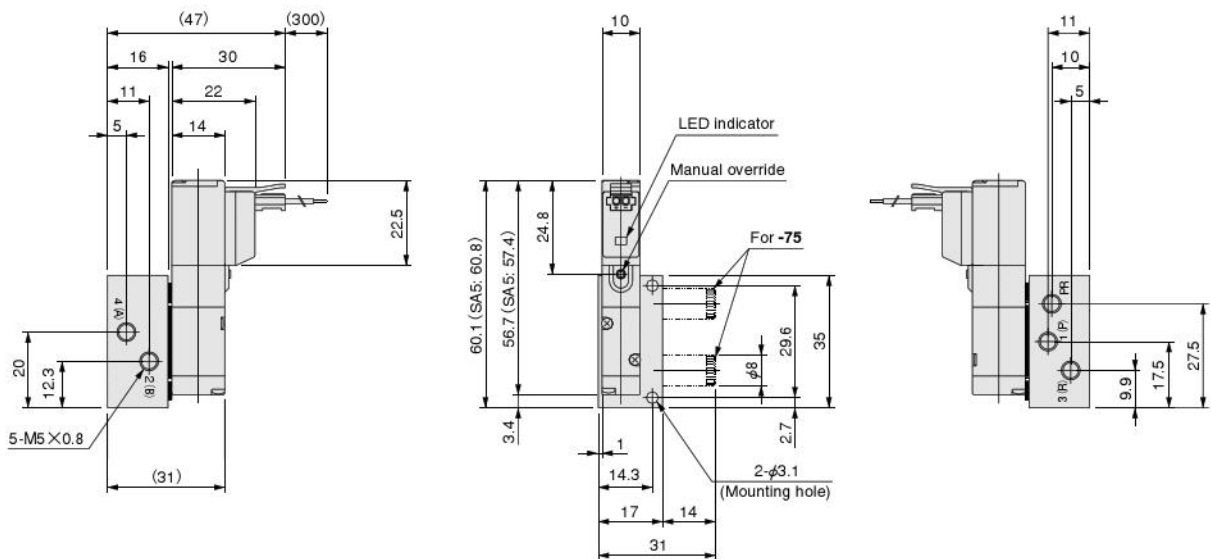

Options

● Mounting base: **-21**

● Locking type manual override: **-81**

● Grommet: **-GL**

● S type plug connector: **-PS**

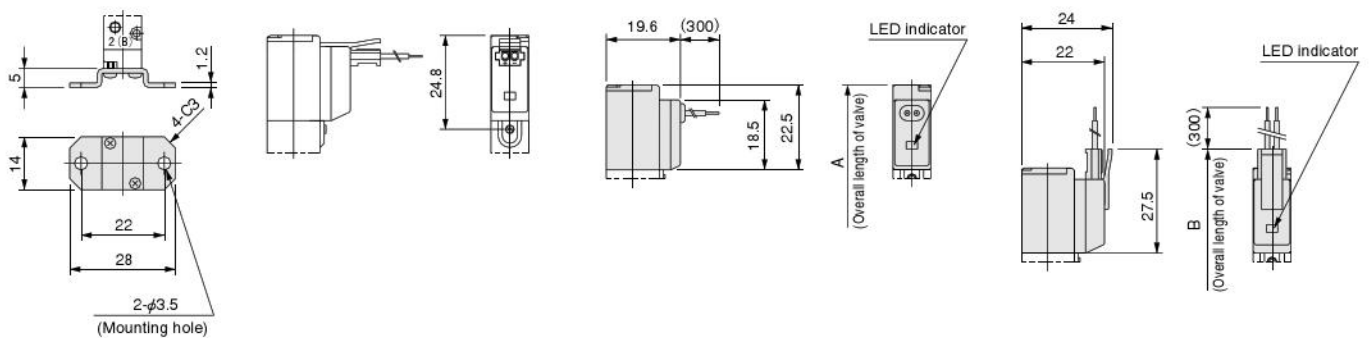

Model	Code	A	B	Remark
EA10F1~EA10F5, EA10A1~EA10A5		56.7	61.7	Overall length to the end of the valve
EA10LF1~EA10LF5, EA10LA1~EA10LA5		—	61.7	
EA10SF1~EA10SF5, EA10SA1~EA10SA5		—	62.4	

mm

Dimensions of EA Series Single Valve Unit (mm)

5-port, double solenoid
EA10□F6-PL

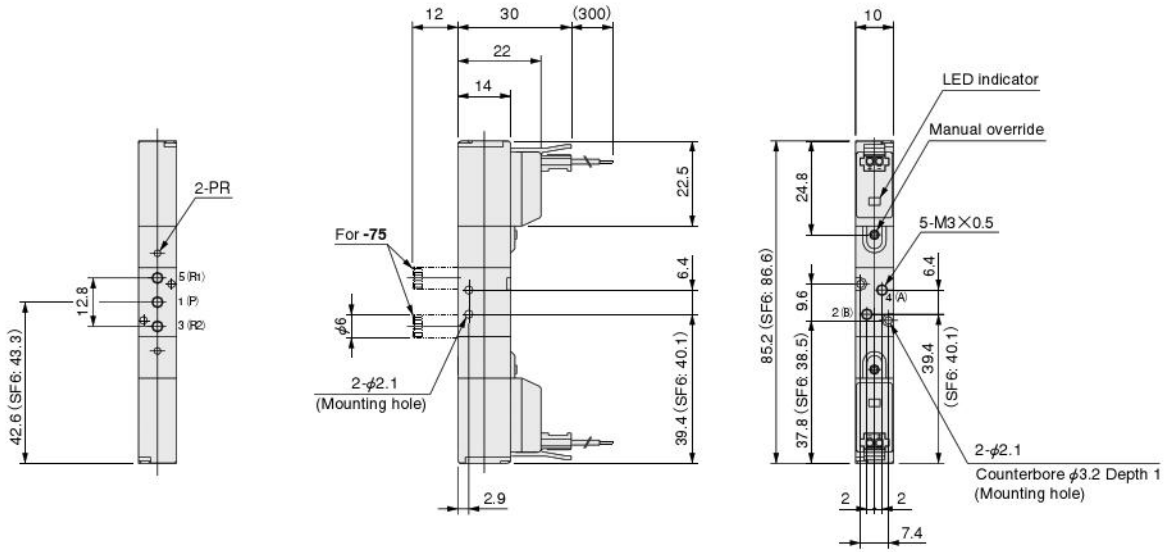

5-port, double solenoid (with sub-base)
EA10□A6-25-PL

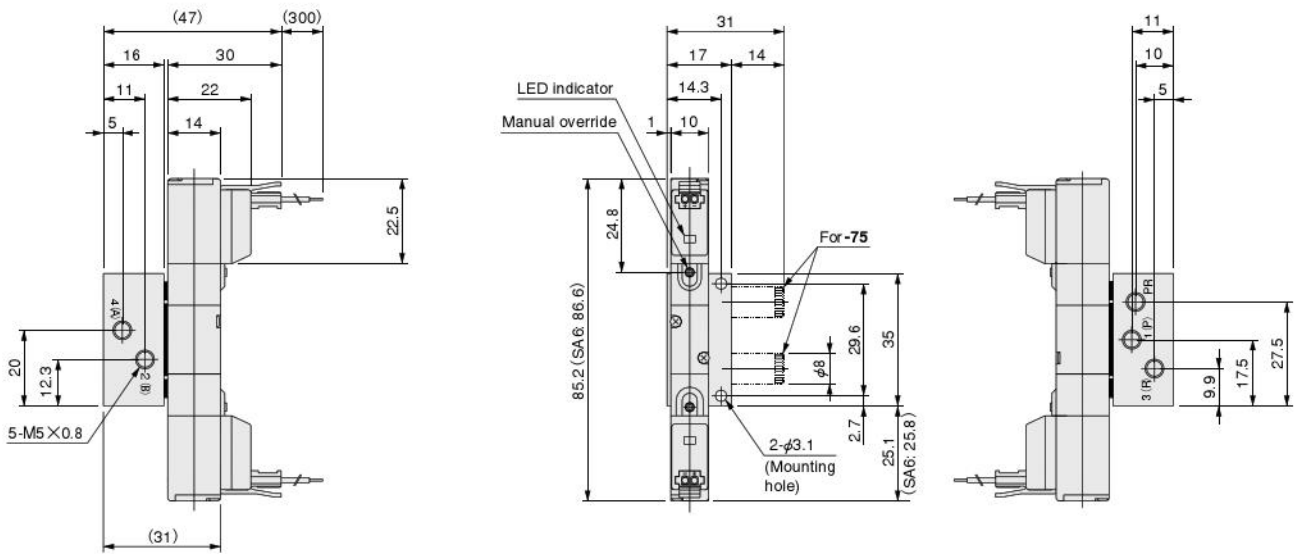

Options

● Locking type manual override: **-81**

● Grommet: **-GL**

● S type plug connector: **-PS**

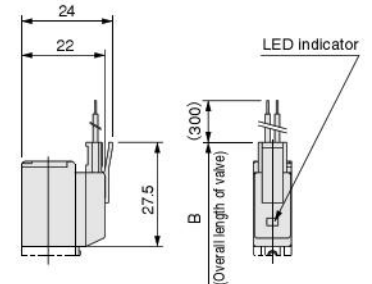
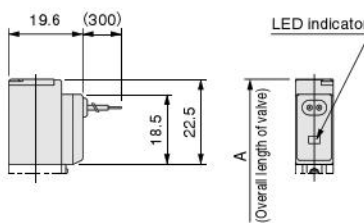
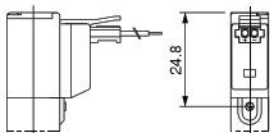

Model	Code	A	B	Remark
EA10F6, EA10A6		85.2	95.2	Overall length to the end of the solenoid on the opposite side
EA10LF6, EA10LA6		—	95.2	
EA10SF6, EA10SA6		—	96.6	

mm

Dimensions of EA Series Manifold (mm)

Manifold for combination mounting of 2, 3, 5-port valves

EAM□F (Direct piping type)

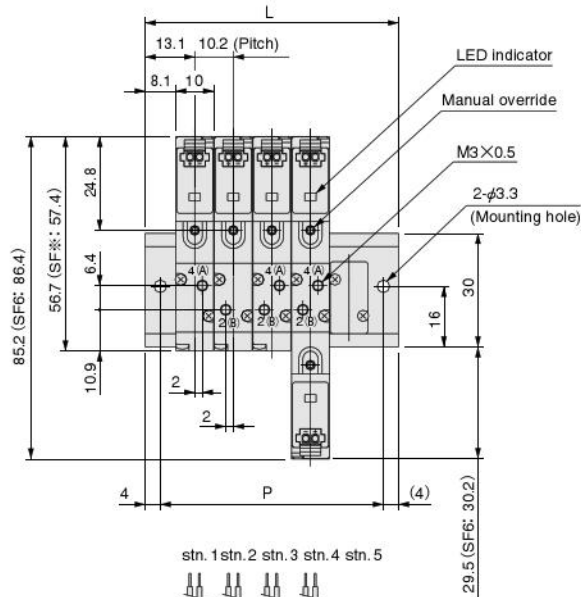
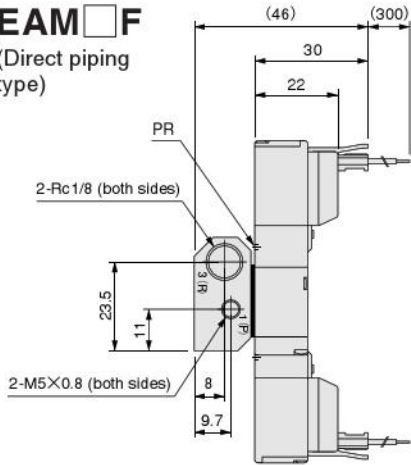

Unit dimensions

Number of units	L	P
2	36.4	28.4
3	46.6	38.6
4	56.8	48.8
5	67.0	59.0
6	77.2	69.2
7	87.4	79.4
8	97.6	89.6
9	107.8	99.8
10	118.0	110.0
11	128.2	120.2
12	138.4	130.4
13	148.6	140.6
14	158.8	150.8
15	169.0	161.0
16	179.2	171.2
17	189.4	181.4
18	199.6	191.6
19	209.8	201.8
20	220.0	212.0

[Installation example]

EAM5F

- stn.1 EA10F3-PL-D4
- stn.2 EA10F4-PL-D4
- stn.3 EA10F5-PL-D4
- stn.4 EA10F6-PL-D4
- stn.5 EABP-F

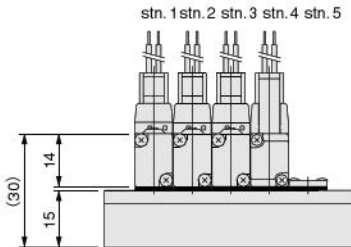

EAM□A (Base piping type)

(Base piping type)

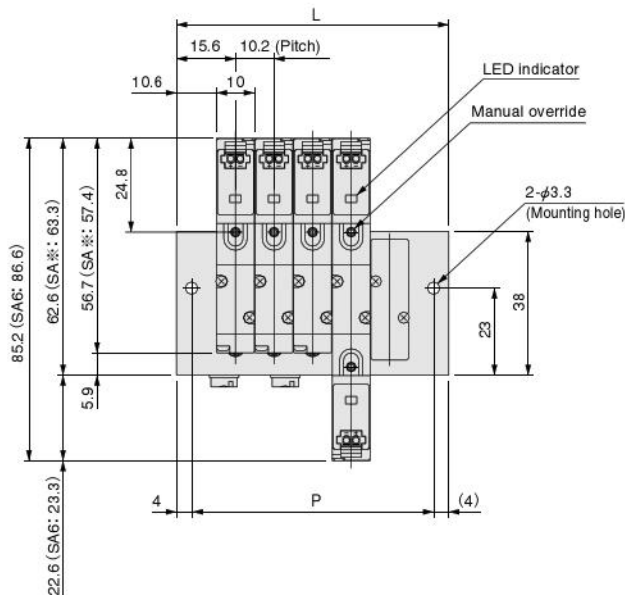
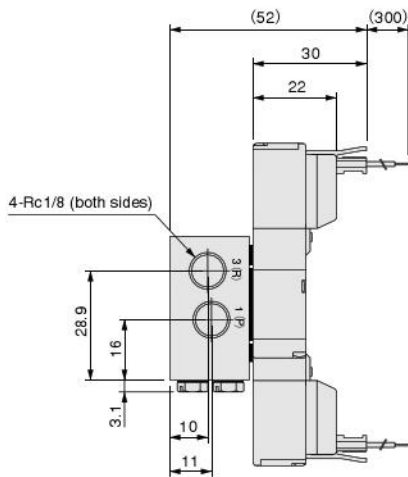

Unit dimensions

Number of units	L	P
2	41.4	33.4
3	51.6	43.6
4	61.8	53.8
5	72.0	64.0
6	82.2	74.2
7	92.4	84.4
8	102.6	94.6
9	112.8	104.8
10	123.0	115.0
11	133.2	125.2
12	143.4	135.4
13	153.6	145.6
14	163.8	155.8
15	174.0	166.0
16	184.2	176.2
17	194.4	186.4
18	204.6	196.6
19	214.8	206.8
20	225.0	217.0

[Installation example]

EAM5A

- stn.1 EA10A3-PL-D4
- stn.2 EA10A4-PL-D4
- stn.3 EA10A5-PL-D4
- stn.4 EA10A6-PL-D4
- stn.5 EABP-A

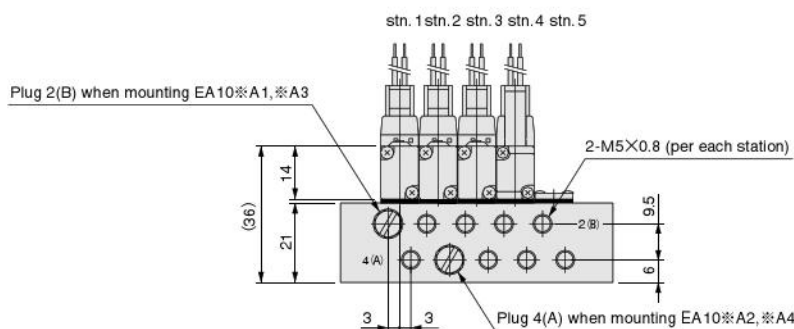

SOLENOID VALVES EA, EB SERIES

Dimensions of EA Series Manifold (mm)

Manifold for combination mounting of 2, 3, 5-port valves

EAM□AJ

(Base piping type with quick fittings)

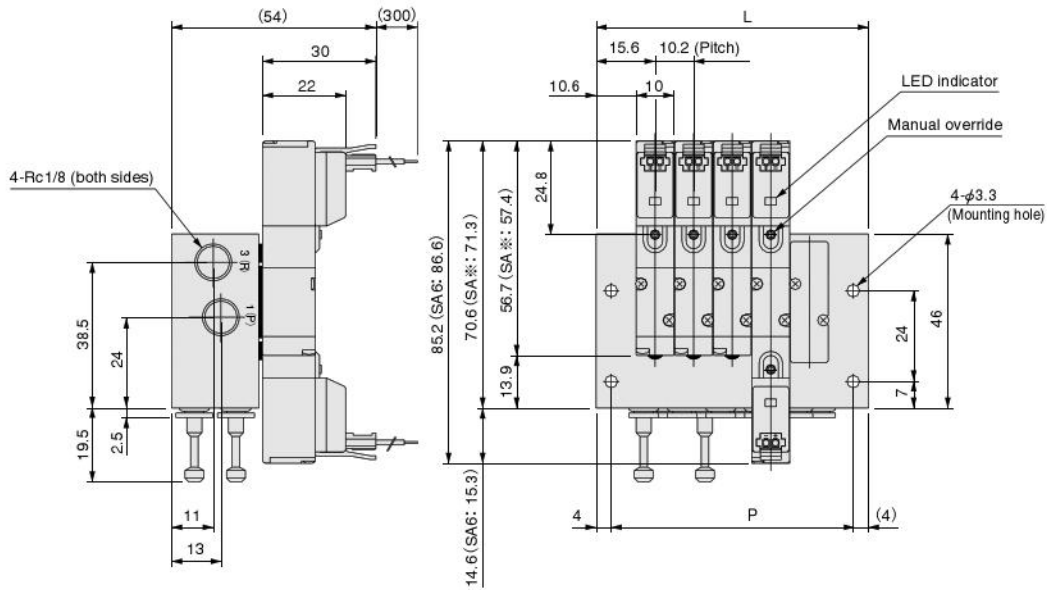

Unit dimensions

Number of units	L	P
2	41.4	33.4
3	51.6	43.6
4	61.8	53.8
5	72.0	64.0
6	82.2	74.2
7	92.4	84.4
8	102.6	94.6
9	112.8	104.8
10	123.0	115.0
11	133.2	125.2
12	143.4	135.4
13	153.6	145.6
14	163.8	155.8
15	174.0	166.0
16	184.2	176.2
17	194.4	186.4
18	204.6	196.6
19	214.8	206.8
20	225.0	217.0

[Installation example]

EAM5AJ

- stn.1 EA10A3-PL-D4
- stn.2 EA10A4-PL-D4
- stn.3 EA10A5-PL-D4
- stn.4 EA10A6-PL-D4
- stn.5 EABP-A

