



Charge Removal, Dust Removal, and Dust Collection Modules

Ion Wiper

“Charge Removal & Dust Removal” Functions and “Dust Collection” Function Split into Modules! Flexible Equipment Design and Layout!

NEW Possible to Create Dust Removal Environment Optimized to Workpiece.

Wide Range of Uses for Module Types!

Can be fastened on commercially available aluminum frames for installation.

Easily Installed In-line

Installation on factory assembly lines fully supported.

Photoelectric sensor can even detect clear workpieces

Optional setting

Full Range of Basic Functions Plus Plenty of Options

Equipped with pulse blower function for more efficient dust removal and lowered air consumption!

Dust collection is now even better.



Blow unit



Collection unit



Box model (A4 and A3 sizes)

Ion Wiper

Eliminate Worries about Charge Removal, Dust Removal, and Dust Collection!

Removal of dust from workpieces can be streamlined and optimized.

I want to run this in-line



In-line mounting is not possible

I want equipment that fits my workpieces

Sizes do not match



I want to boost dust removal and collection performance



Poor dust removal and dust collection



Solve these **problems** with **Module Type Ion Wiper!**



Blow unit



Dust collection unit

Module type allows you to design equipment to match your layout.



Ion wiper's charge removal and dust removal functions and dust collection function split into modules.

Charge removal, dust removal, and dust collection units can flexibly handle various needs and a wide range of workpiece sizes.

Ion Wiper

- Introduction merits:**
- Fits any workpiece and equipment format.
 - Can be installed in-line.
 - Basic functions fully operational and many options available.

Users can flexibly design box

Blow unit

- Removes electric charge with ion air
- Removes dust with blowing air

Image of air flow for charge removal, dust removal, and dust collection

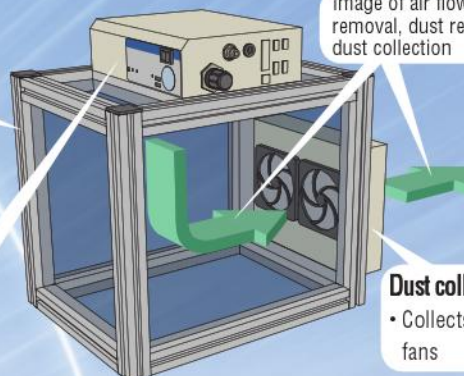

Dust collection unit

- Collects dust with fans

Improved dust removal and dust collection performance

Full Range of Basic Functions Include Powerful Dust Removal and Dust Collection

Blow unit

- High-frequency AC system, with ionizer blow type (DTY-ELK01) with excellent ion balance built into main unit.
- Equipped with pulse blow function for more effective dust removal with lower air consumption.
- Equipped with 1 ion air nozzle for removing charge and 2 air blow nozzles for removing dust (optional nozzle joint can be used to adjust angles).
- Wide range of nozzle variations.
- Photoelectric sensor can be connected to detect clear workpieces (option).
- Connecting an electrostatic potential sensor allows you to control charge removal process.
- External input/output can be installed to allow external controller to be connected.
- Support software is available for various settings. (free of charge)

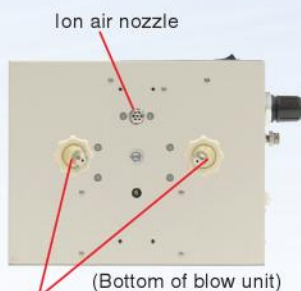

Ion air nozzle
Nozzle for blowing air



Optimized to size of workpieces

Shape of unit can be flexibly designed

Installation possible using commercially available aluminum frames

By using commercially available aluminum frames, you can build the box to match the size and shape of your workpieces. (recommended size for aluminum frame: □ 20 mm [0.787 in.]

Dust collection unit

- Improved dust collection performance (approximately double our DTY-WCM model)
- Dust sensor can be mounted on Dust collection unit (select by model)*1.



*1 The dust sensor's values are estimates, and do not guarantee that dust has been removed from the workpiece.

Can be used in-line

Easily Installed In-line

Installed on production equipment

Supports installation in line, such as on conveyors or with automated equipment.

Can handle a variety of needs ranging from mass production, to automation, to unmanned production.

Shape of unit can be flexibly designed

Mounting format means installation is possible using commercially available aluminum frames. Create a frame that suits your workpieces.

- High frequency AC system, with built-in ionizer blow type (DTY-ELK01) with excellent ion balance.
- Equipped with pulse blow function
- Operation switches on front panel can set blowing time and frequency of intermittent blowing (pulse blow).*
- Equipped with user area where blow unit operations (blowing time and intermittent frequency) and dust collection unit operations can be set as needed.

* Only the air blower operates intermittently. The ion air function does not do intermittent blowing.

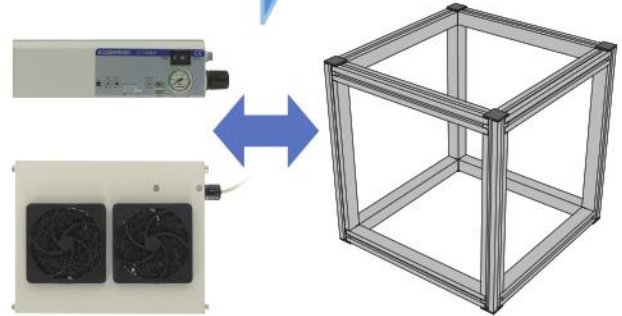

Installation possible using commercially available aluminum frames

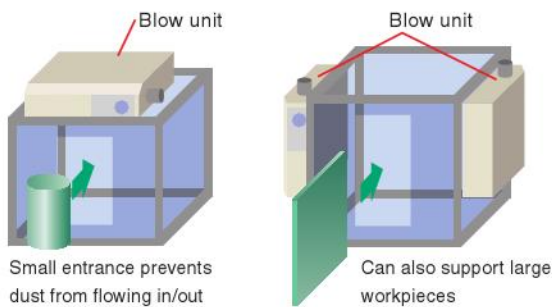

Entrance made small to suit small workpieces, or for large workpieces dual mount front and back blow units (using 2 units) can be used to remove electric charges and dust from both sides.

Units separated for efficient dust collection

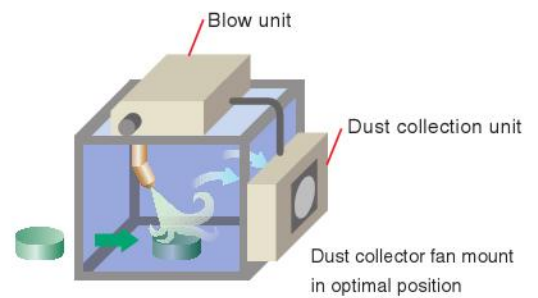

Air flow can be optimized inside the box by adjusting the installation position of the blow unit and dust collection unit. Complex workpieces can also be flexibly handled.

Example applications installed using commercially available aluminum frames

Common application example

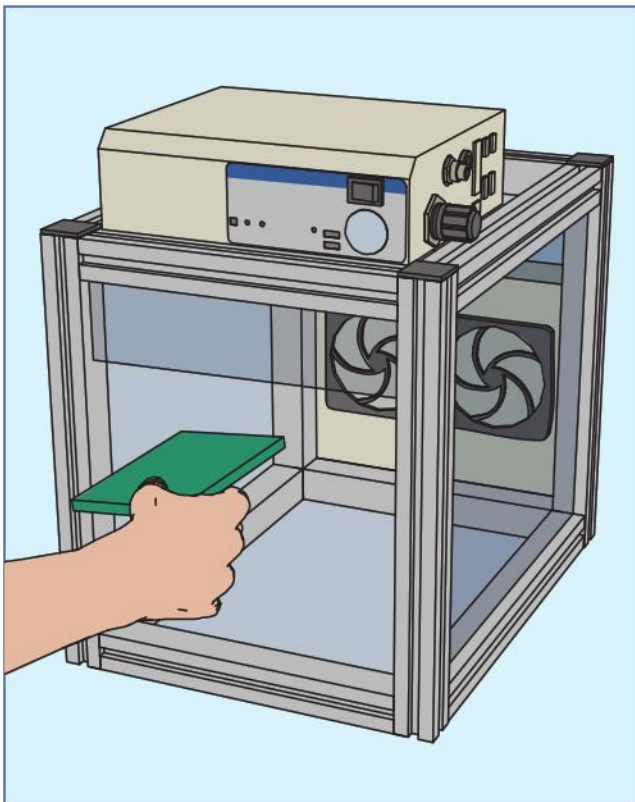

Units can be designed to suit charge removal & dust removal processes (Example installed on side of work surface)

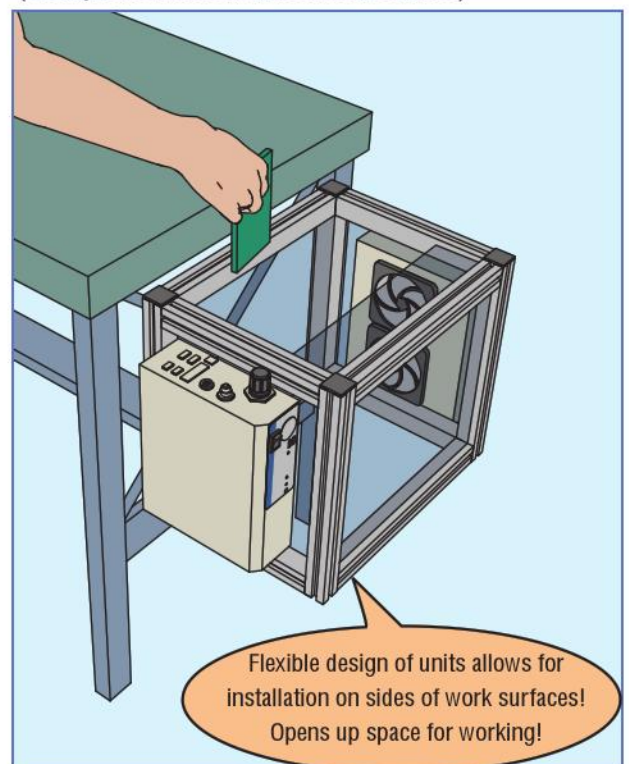

Easily Installed In-line

Unitized system simplifies in line compatibility.
User design work can be reduced.

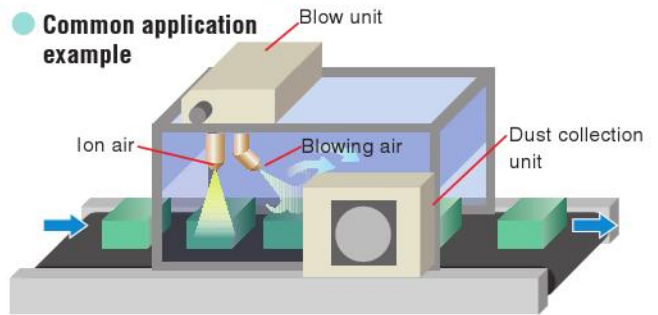

Example of in-line installation

● **Example using multiple units**

Multiple units installed to streamline work

Multiple units can be installed according to the shape of workpieces and speed of line. Removed dust is collected by dust collection fans so dust doesn't fly about.

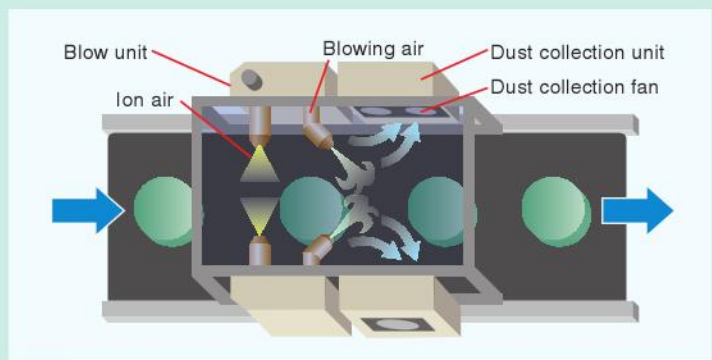

● **When using system control**

Acquiring information from multiple connected units

Line controls can also be supported by using sensor information and by doing batch management of settings. These are also effective for identifying causes of problems when they occur.



Support Software

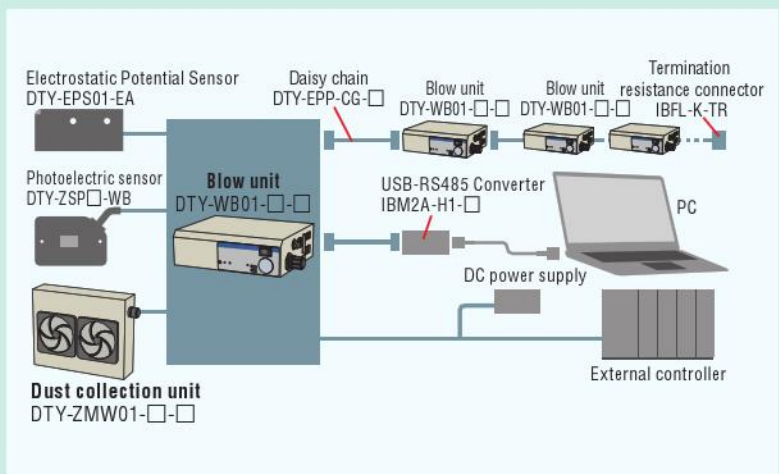

● **System requirements for supported software**

Supported OS	Windows 7 SP1, Windows 8.1, Windows 10
CPU	1 GHz or faster, 32 bit (x86) or 64 bit (x64) processor
Memory	2 GB or more
Hard disk	500 MB or more open space
Display	Resolution of 1024 × 768 or better
Other	.NET Framework Version 4.6.1 or later

Full Range of Basic Functions Plus Plenty of Options

Full range of basic functions complement separate charge removal and dust removal functions and dust collection function.

Wide range of options improve ease of use.

Increase dust removal performance by separating nozzles



Specialized nozzles for blowing air

- * Angles can be adjusted (option)
- * Comes with pulse blower function

Ion air

Separated nozzle for ion air and nozzle for blowing air. Air blower angles can be adjusted and they support pulse blowing too. (Nozzles and nozzle joints for adjusting angles are options)

Boosts dust collection performance too



Dust collection units can be installed separately from the blow units, plus 2 units can be connected. Flexible arrangements are possible to suit the workpiece, such as adjusting the dust collection positions and boosting dust collection performance.

Wide range of options

Variety of sensors needed to verify processes are available.

Photoelectric sensors, which can **also handle transparent workpieces**, support consistent work that is not limited by the color of workpieces. There are also a wide range of nozzle variations that can flexibly support a variety of needs.



Photoelectric sensor/electrostatic potential sensor

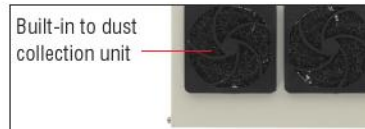

Dust sensor



Nozzle variations

Example box models (equivalent to A4 and A3 sizes)



DTY-WBM01-S



DTY-WBM01-L

* Just boxes by themselves are also available.



Procedure to Operate Ion Wiper



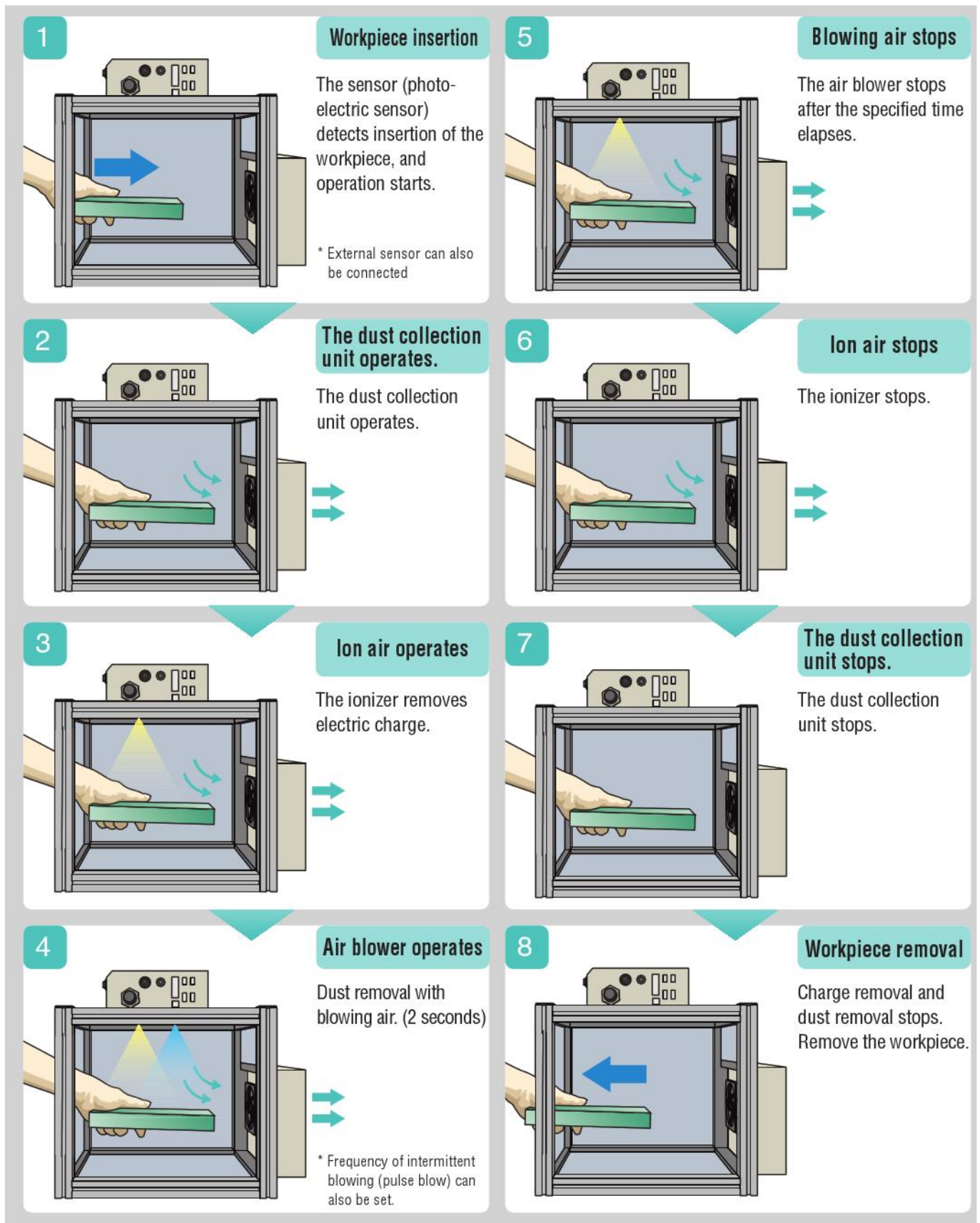

Operation Example: When the air blowing time is set to 2 seconds.
 Inserting a workpiece executes each function in the sequence illustrated below.



Note: The air blowing time and intermittent frequency can be set for the air blowing time switch and the intermittent blowing frequency switch. Furthermore, the support software can be used to set the blowing time, intermittent frequency, and the time interval between each operation to match the user's environment.

Before selecting and using products, please read all the Safety Precautions carefully to ensure proper product use. The Safety Precautions shown below are to help you use the product safely and correctly, and to prevent injury or damage to assets beforehand. Follow the safety precautions for: ISO4414 (Pneumatic fluid power - General rules and safety requirements for systems and their components) and JIS B 8370 (General rules relating to pneumatic systems).

The directions are ranked according to degree of potential danger or damage: “DANGER!”, “WARNING!”, “CAUTION!”, and “ATTENTION!”

 DANGER	Indicates situations that can be clearly predicted as dangerous. If the noted danger is not avoided, it could result in death or serious injury. It could also result in damage or destruction of assets.
 WARNING	Indicates situations that, while not immediately dangerous, could become dangerous. If the noted danger is not avoided, it could result in death or serious injury. It could also result in damage or destruction of assets.
 CAUTION	Indicates situations that, while not immediately dangerous, could become dangerous. If the noted danger is not avoided, it could result in light or semi-serious injury. It could also result in damage or destruction of assets.
 ATTENTION	While there is little chance of injury, this content refers to points that should be observed for appropriate use of the product.

- **This product was designed and manufactured as parts for use in General Industrial Machinery.**
- When selecting and handling equipment, the system designer or another person with sufficient knowledge and experience should always read the safety precautions, catalog, instruction manual and other literature before commencing operation. Making mistakes in handling is dangerous.
- After reading the instruction manual, catalog, and other documentation, always store them in a location that allows easy availability for reference to users of this product.
- Whenever transferring or lending the product to another person, always attach the catalog, instruction manual, and other information, to the product where they are easily visible in order to ensure that the new user can use the product safely and properly.
- The danger, warning, and caution items listed under these “Safety Precautions” do not cover all possible cases. Read the Catalog and Owner’s Manual carefully, and always keep safety first.

 **DANGER**

- Do not use for the applications listed below:
 1. Medical equipment related to maintenance or management of human lives or bodies.
 2. Mechanical devices or equipment designed for the purpose of moving or transporting people.
 3. Critical safety components in mechanical devices.
 This product has not been planned or designed for purposes that require advanced stages of safety. It could cause injury to human life.
- Do not use the product in locations with or near dangerous substances, such as flammable or ignitable substances. This product is not explosion-proof. It could ignite or burst into flames.
- When mounting the product, always firmly support and secure it (including nozzles). Dropping or falling the product or improper operation could result in injury.
- Persons using a pacemaker or other similar medical devices should maintain a distance of at least one meter [3.281 ft] away from the product. Getting too close to the product creates the risk of causing pacemakers to malfunction due to the magnetic fields.
- Never attempt inappropriate disassembly or assembly of the product related to basic construction, performance, or functions. Doing so could cause abnormal operations, injury, electric shock, fire, etc.
- Do not splash water on the product. Spraying water on the product, washing the product, or using the product under water creates the risk of malfunction, leading to injury, electric shock, fire, etc.
- Before doing inspections, cleaning, or maintenance, be sure to turn off the power. Failure to do so creates the risk of electric shock.
- Never attempt to remodel the product. Doing so creates the risk of injury, electric shock, fire, etc. due to abnormal operations.

 **WARNING**

- Do not use the product in excess of its specification range. Doing so creates the risk of product breakdown, loss of function, or damage. It could also drastically reduce the operating life.
- Provide adequate shielding measure for use in the locations described below. Failure to do so creates the risk of abnormal operations, and could cause injury or damage to equipment.
 1. Locations where large electric currents or strong magnetic fields are generated
 2. Locations where there is the possibility of exposure to radiation.
- Use safety circuits or system designs to prevent damage to machinery or injury to personnel when the machine is shut down due to emergency stop or electrical power failure.
- Do not wire parallel to or in the same conduit as power lines or high-voltage lines. Noise may cause devices to malfunction.
- Before supplying electricity to the device and before starting operation, always conduct a safety check of the area where the machine is operating. Unintentional supply of air or electricity could possibly result in electric shock, or in injury caused by contact with moving parts.

- Do not touch the discharge needle, terminals, etc., while the device is on. There is a possibility of electric shock and abnormal operation.
- Do not throw the product into fire. The product could explode and/or produce toxic gases.
- Do not sit on the product, place your feet on it, or place other objects on it. Accidents such as falling could result in injury. Dropping or toppling the product may result in injury, or it might also damage or break it, resulting in abnormal or erratic operation, runaway, etc.
- Before conducting maintenance, inspection, repair, replacement, or any other similar work, always completely cut off all the electric supply.
- Before performing any kind of wiring work, be sure to turn off the power. Failure to do so creates the risk of electric shock.
- Do not allow any cords, such as the power cords and lead wires, to become damaged. Allowing the cords to be damaged, bent excessively, pulled, rolled up, placed under heavy objects or squeezed between two objects, may result in current leaks or defective continuity that will lead to fire, electric shock, or abnormal operation.
- Do not connect or disconnect connectors while the power is turned on. Also, never apply unnecessary force to connectors. Doing so creates the risk of personal injury, device damage, and electric shock due to abnormal machine operation.
- Check the instruction manual for information to correctly install the product’s wiring and piping. Incorrect wiring or piping could result in damage or abnormal operation.
- After completing wiring work, check to make sure that all connections are correct before turning on the power.
- Correctly apply the rated voltage to the product. Applying the wrong voltage will make it impossible to obtain the rated function, and creates the risk of damage to and burnout of the product.
- Do not place the AC adapter cables, or power or signal wires that are provided with the products, on moving parts, because there is a risk the wires may break.
- Stop using the devices if you notice smoke, or strange smells or noises. There is a risk of fire or electric shock.

 **CAUTION**

- Do not use in locations that are subject to direct sunlight (ultraviolet rays), dust, salt, iron powder, or extreme humidity. Do not use in environments that include organic solvents, phosphate ester based hydraulic oil, sulfur dioxide, chlorine gas, or acids. Such conditions can lead to premature loss of functions, sudden degradation of performance, and reduced operating life.
- Tiny electronic parts are used in the devices. When handling the product, do not hit it, drop it, bump it, or subject it to excessive impact. Even if the exterior of the product appears undamaged, damage to internal components can cause abnormal operation.
- When installing the product, leave room for adequate working space around it. Failure to ensure adequate working space will make it more difficult to conduct daily inspections or maintenance, which could eventually lead to system shutdown or damage to the product.

Safety Precautions (Common to All Ionizers)

- Always be sure to post a "Work in Progress" sign during installation, adjustment, or other operations, to avoid unintended supply of electric power, etc. Turning on the power unexpectedly could cause injury due to electric shock or abrupt operations.



ATTENTION

- When considering the possibility of using this product in situations or environments not specifically noted in the Catalog or Owner's Manual, or in applications where safety is an important requirement such as in an air-plane facility, combustion equipment, leisure equipment, safety equipment, and other places where human life or assets may be greatly affected, take adequate safety precautions such as an application with enough margins for ratings and performance or failsafe measure. Be sure to consult us with such applications.
- Check the instruction manual for information to install the product's wiring and piping.
- When handling the product, wear protective gloves, safety glasses, safety shoes, etc., to keep safety.
- When the product can no longer be used, or is no longer necessary, dispose of it appropriately as industrial waste.
- Devices can exhibit degraded performance and function over their operating life. Conduct daily inspections and confirm that all requisite system functions are satisfied to prevent accidents from happening.



Other

- When using the product in a system, use only genuine Koganei parts or compatible parts (recommended parts).
When conducting maintenance and repairs, always use genuine KOGANEI parts or compatible parts (recommended parts).
Always observe the required methods.

Koganei cannot be responsible if these items are not properly observed.

Safety Precautions for Ionizers



DANGER

- High voltages are applied to the discharge needle, so there is a risk of electric shock. Never touch the discharge needle when the power is on.



WARNING

- The tip of the discharge needle is sharp, so be careful when handling it. Incorrect handling may result in injury.
- Before doing any kind of operation to products that use compressed air, such as maintenance, inspection, repair, connecting or disconnecting piping, or replacements, always turn off the air supply completely and confirm that residual pressure inside the product or in piping connected to the product is zero. In particular, be aware that residual air will still be in the air compressor or air storage tank.
- The medium used by the ionizer is air. Do not use any other medium.
- Always supply air pressure to ionizers that use compressed air before supplying electric power. Supplying electric power while no air pressure is supplied may have a bad effect on the devices and their environment.
- Before applying air pressure, confirm that the discharge needle unit is locked (fastened).



CAUTION

- The ionizer generates ozone while exposed to the atmosphere. Do not use it in particularly enclosed spaces. Furthermore, ventilation is required when multiple units are used.
- Do not place your face near the nozzle of the ion air blower to confirm the smell of ozone. Your nose and throat could become sore.
- Do not use ionizers for any purpose other than removing static charges.
- Before doing piping work, thoroughly flush the inside of the pipes (blow out with compressed air). Machining chips, sealing tape, rust and other debris remaining from the work may result in air leaks and malfunctions.

- Use clean air that contains no oil or moisture as the medium.
To select an air compressor for the blow type products, refer to page 164 in Catalog No. R0006 "Static Electricity Removal Unit Ionizers".
- This product cannot be used if the medium or ambient atmosphere includes any of the substances below. Organic solvents, phosphate type hydraulic oil, sulfur dioxide gas, chlorine gas, or acids.
- The static charge removal effect may not be achieved, even by spraying ions, if the electrostatically charged object is contiguous to or in contact with another object. When installing the ionizer, be very careful about the environment around the objects from which the charge is to be removed.
- Static charge removal performance is reduced when the ionizer is not fully grounded.
- The operating life of the discharge needle varies depending on the condition of the usage environment. Maintenance is required because loss of performance may occur when the usage environment is poor (such as an atmosphere with high humidity) or when the discharge needle is not clean.
- Note that there is an inrush current when the power is turned on.

Handling Instructions and Precautions (Common Precautions)



General precautions

1. Do not allow excessive external forces to act on the product.
2. Do not disassemble or modify the product.
3. Do not expose the product to ultraviolet light or wind and rain.

Mounting

1. The mounting surface must be flat. Twisting or bending during mounting could result in defective operation.
2. When installing the devices, be careful of water and oil contamination, high temperatures, and high humidity. Especially avoid locations on which condensation forms.

Wiring

1. When using a power supply with a commercially available switching regulator, be sure to connect a frame ground (F.G.).
2. When using devices that generate noise (switching regulator, inverter motor, etc.) in the vicinity of the installation, be sure to connect a frame ground (F.G.) to the devices.
3. After completing wiring work, check to make sure that all connections are correct.

Cautions during use

1. Before doing inspections, cleaning, or maintenance, be sure to turn off the power.
2. Always contact Koganei if there is a breakdown, because adjustments and repairs will be necessary.
3. Maintenance is an extremely important aspect for maintaining performance. Do periodic maintenance according to the product's instruction manual.
For the ionizer's discharge needle maintenance period (guidelines) and discharge needle cleaning procedure, refer to page 165 to 166 in Catalog No. R0006 "Static Electricity Removal Unit Ionizers".
4. Periodically check that there is no ozone deterioration on devices and components (particularly NBR and other things that have low resistance to ozone) that are used near the ionizer.
5. Do not use with moving parts that are subject to vibration or impact.
6. The product uses grease on internal sliding parts.

Warranty and General Disclaimer

1. Warranty Period

The warranty period for Koganei products is 1 year from the date of delivery.

* However, some products have a 2-year warranty; contact your nearest Koganei sales office or the Koganei overseas department for details.

2. Scope of Warranty and General Disclaimer

- (1) When a product purchased from Koganei or from an authorized Koganei distributor or agent malfunctions during the warranty period in a way that is attributable to Koganei's responsibility, Koganei will repair or replace the product free of charge. Even if a product is still within the warranty period, its durability is determined by its operation cycles and other factors. Contact your nearest Koganei sales office or the Koganei overseas department for details.
- (2) The Koganei product warranty covers individual products. Therefore, Koganei is not responsible for incidental losses (repair of this product, various expenses required for replacement, etc.) caused by breakdown, loss of function, or loss of performance of Koganei products.
- (3) Koganei is not responsible for any losses or for any damages to other machinery caused by breakdown, loss of function, or loss of performance of Koganei products.
- (4) Koganei is not responsible for any losses due to use or storage of the product in a way that is outside of the product specifications prescribed in Koganei catalogs and instruction manuals, and/or due to actions that violate the mounting, installation, adjustment, maintenance or other safety precautions.
- (5) Koganei is not responsible for any losses caused by breakdown of the product due to factors outside the responsibility of Koganei, including but not limited to fire, natural disaster, the actions of third parties, and intentional actions or errors by the purchaser.

Blow unit



Specifications

Model		DTY-WB01-□-□
Input voltage	V	24 VDC ±5%
Consumption current	A	Max:0.6
Built-in ionizer		DTY-ELK01 (1 unit)
Built-in solenoid valve		230E1-SR-26W-24 VDC
Ion balance ^{Note 1}	V	±15 (standard nozzle, set pressure 0.5 MPa [73 psi], 50 mm [1.969 in.] from tip of nozzle)
Static charge elimination time ^{Note 1}	sec	1 (1000V→100V, 0.5 MPa [73 psi], 50 mm [1.969 in.])
Medium		Air (clean air that contains no moisture or oil)
Operating pressure range	MPa [psi]	0.2 to 0.7 [29 to 102]
Ion air set pressure range	MPa [psi]	0.05 to 0.5 [7 to 73]
Port size		φ8 [0.315] Quick fitting
Air blowing time	sec	0.5 to 10, continuous (rotary switch, 16 points) (sensor off delay during continuous operation: 0.1 to 3.0 sec)
Intermittent blowing frequency ^{Note 3}	Hz	1, 2, 3, 4, 6, 8, 10, continuous (non intermittent) (rotary switch, 10 points) Including 2 user settings areas
Switch		Power on/off Count ionizer discharge time, On: Enabled/Off: Disabled Count number of valve operations for blowing: On: Enabled/Off Disabled
Display		POWER: (green, power), ALM: (red, abnormal) MAINT: (yellow, maintenance), ION BLOW: (blue, blowing) EPS: (yellow, electrostatic potential sensor judging), DUST: (red/green/blue, state of dust sensor)
Nozzle (option)		Shower type: 60°, 90°, flat (3 types) Pinpoint type: φ2 [0.079], φ3 [0.118], φ4 [0.157] (3 types)
Consumed air flow ^{Note 2}	ℓ/min	Ion air side: 170 (ANR) [6.0 (SCFM)], air blowing side: 330 (ANR) [11.7 (SCFM)]
Communication		RS485 communication
Number of communication connections	Units	15
Usage environment		Indoor 0 to 40°C [32 to 104°F], 15 to 65% RH (with no condensation)
Accessories		4 L brackets (with screws) provided, owner's manual
Weight	kg [lb]	2.1 [4.630] (excluding nozzles/photoelectric sensor/power source)

Note 1: Measurements are made using Koganei measurement methods and conditions.

Note 2: Nozzles: Pinpoint is φ2 [0.079]x2 locations, shower is 60°/when throttle valve is fully open; feed pressure is 0.7 MPa [102 psi]; and set pressure for ion air regulator is 0.5 MPa [73 psi]

Note 3: Only the air blow operates intermittently. The ion air function does not do intermittent blowing.

* The product uses grease on internal sliding parts.

Specifications for external output

Model		DTY-WB01-□-□
External input/output	Output	ALARM: (abnormal output), CHECK: (ionizer discharge abnormal output) MAINT: (maintenance period output), EPS: (electrostatic potential sensor judgment output) DUST: (dust sensor judgment output), END: (blow operation end output) VAC START: (external device operation output) (NPN open collector 24 VDC/Max 50 mA)
	Input	STOP: (operation stop input), START (operation start input) ZC: (electrostatic potential sensor calibration input) (Input current 4.8 mA/at 24 VDC)
Possible sensor connections (optional)		Photoelectric sensor: DTY-ZSP□L-WB Electrostatic potential sensor: DTY-ESP01-EA-□LWB Dust sensor (dust collection unit: built-in to DTY-ZMW01-□-DS)

Dust collection unit



Specifications

Model	DTY-ZMW01-□	DTY-ZMW01-□-DS
Consumption current	A	Max: 1.0 (when dust collection fan is running: Max: 2.0)
Dust collection fan exhaust flow rate	ℓ/min [ft ³ /min]	2000 [71]
Filter scavenging performance	%	62 [0.266] ^{Note 1}
Dust sensor ^{Note 2}	None	Available
Accessories	4 L brackets (with screws) provided	
Usage environment	Indoor 0 to 40°C [32 to 104°F], 15 to 65% RH (with no condensation)	
Weight	kg [lb]	1.3 [2.866] (with dust sensor)

Note 1: Testing Procedure: ASHRAE52.1-1992 (mass method)
Test dust: ASHRAE TEST DUST

Note 2: The values output by the dust sensor are estimates, and do not guarantee that dust has been removed from the workpiece.

* The dust collection unit cannot operate by itself. A blow unit must be connected to use it.

Example wiring specifications

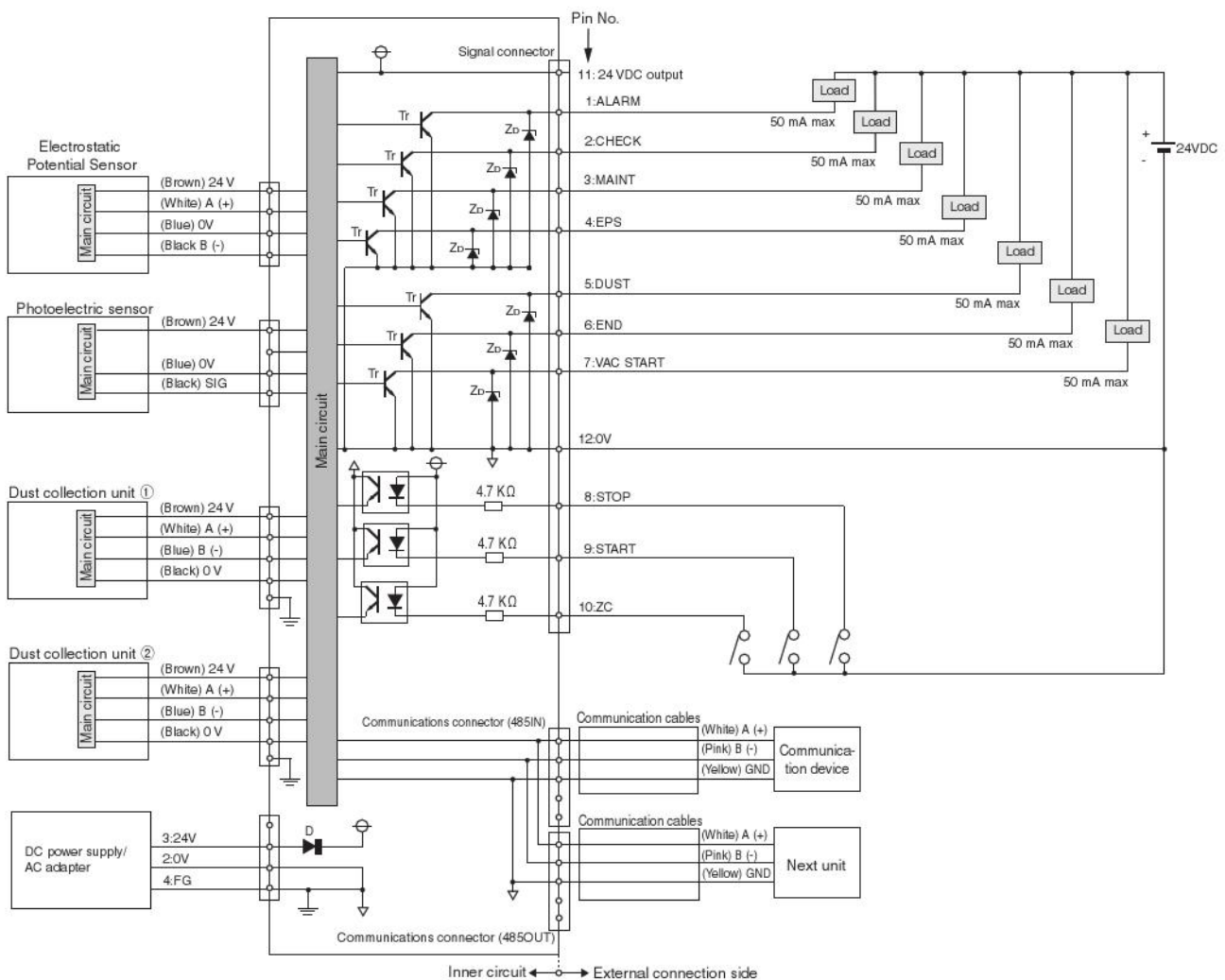

Order Codes

● Blow unit

DTY - WB 01 - -

Ion Wiper Blow Unit

Power supply
Blank: None

3L : 1 power cable provided (cable length: 3 m [9.843 ft]) (DTY-ZDW-3L)

5L : 1 power cable provided (cable length: 5 m [16.404 ft]) (DTY-ZDW-5L)

PS : 1 AC power adapter provided (DTY-ZPS4)

Photoelectric sensor

Blank: None

1PR : 1 sensor provided (cable length: 1 m [3.281 ft])
(DTY-ZSP1L-WB)

3PR : 1 sensor provided (cable length: 3 m [9.843 ft])
(DTY-ZSP3L-WB)



* L brackets provided
Nozzles are not included.

● Dust collection unit

DTY - ZMW01 - -

Cable length

1L: 1 m [3.281 ft]

3L: 3 m [9.843 ft]

Dust sensor

Blank: No Dust sensor

DS : With dust sensor



* L brackets provided

● Nozzle

DTY - NZW -

Type

PP02 : Pinpoint $\phi 2$ [0.079]

PP03 : Pinpoint $\phi 3$ [0.118]

PP04 : Pinpoint $\phi 4$ [0.157]

SW60 : Shower nozzle 60°

SW90 : Shower nozzle 90°

FT01 : Flat nozzle

NJ01 : Nozzle joint

(for adjusting angles)

* PP02 is specifically for blowing air.



Flat nozzle



Nozzle joint

● Communication cable (for daisy chain)

DTY - EPP - CG -

Cable length

1RL : 1 m [3.281 ft]

3RL : 3 m [9.843 ft]



● Communication cable (for upper controller)

DTY - EPP - CG -

Cable length

1RLN : 1 m [3.281 ft]

3RLN : 3 m [9.843 ft]

10RLN: 10 m [32.808 ft]



● Power cable

DTY - ZDW -

Cable length

3L : 3 m [9.843 ft]

5L : 5 m [16.404 ft]



● AC adapter

DTY - ZPS4



Rated input: 100 to 240 ACV

50/60Hz

Output : 24 VDC, 2.71 A

Order Codes

● L brackets
DTY - ZBRL - WB



* 1 bolt (M4) included

● Termination resistance connector
IBFL - K - TR



● USB-RS485 Converter
IBM2A - H1 -



Cable included
Blank: USB (mini-B) ⇔ USB (A), male
N : Cable not included

● Box
DTY - ZBW01 -

Size
S: Equivalent to A4 size
L: Equivalent to A3 size



Equivalent to A4 size



Equivalent to A3-size

● Filter
DTY - - WB

Type
ZFF: For intake (1 set of 6 sheets)
ZFR: For exhaust (1 set of 5 sheets)

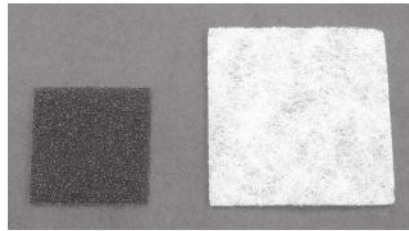

For intake

For exhaust

● Mounting bracket for aluminum frame

DTY - ZBRA - WB

* 4 screws (M4x6) included

● Mounting bracket for aluminum frame duct

DTY - ZBRB - WB

* 1 flange & 4 screws for mounting flange included
(recommended hose nominal diameter: ϕ 75 [2.953])

● Nut for aluminum frame

DTY - ZNW -

Screw size
M3
M4

● Replacement solenoid valve

230E1 - SR - 26W - 24 VDC

Dimensions (mm [in.])

Blow unit

● DTY-WB01-□-□

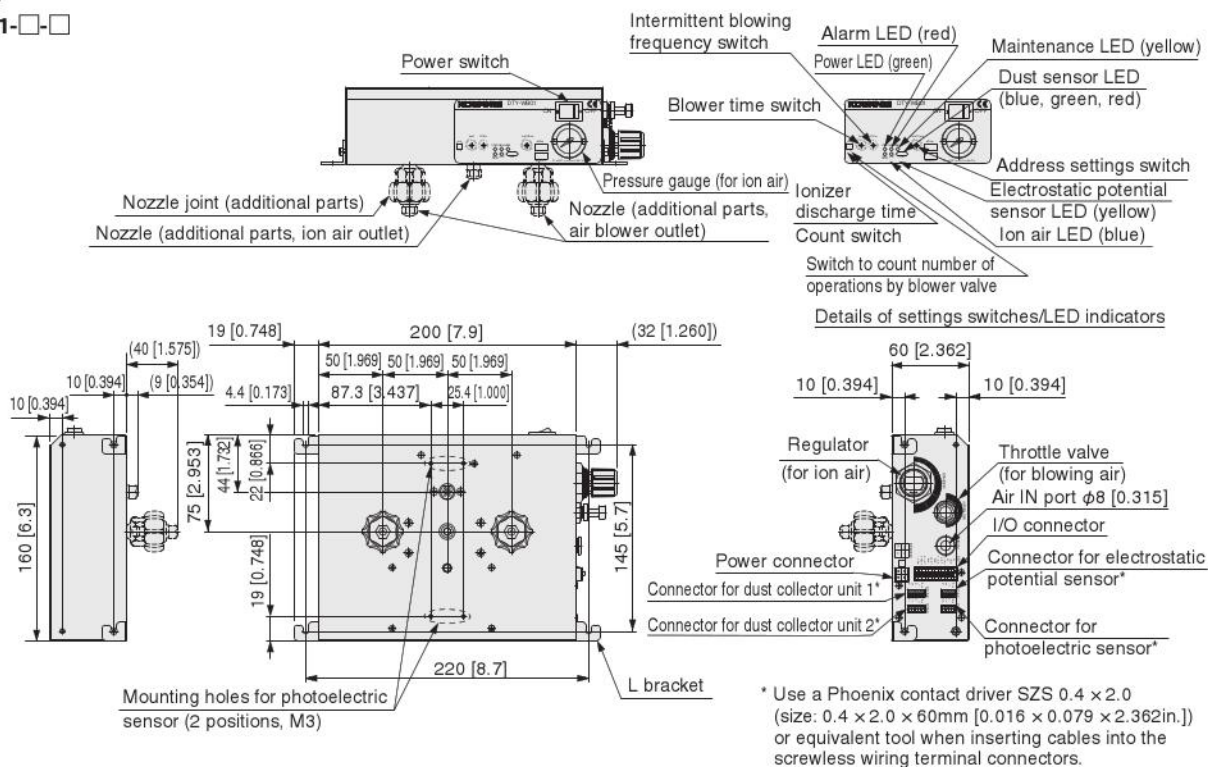

Dust collection unit

● DTY-ZMW01-□-□

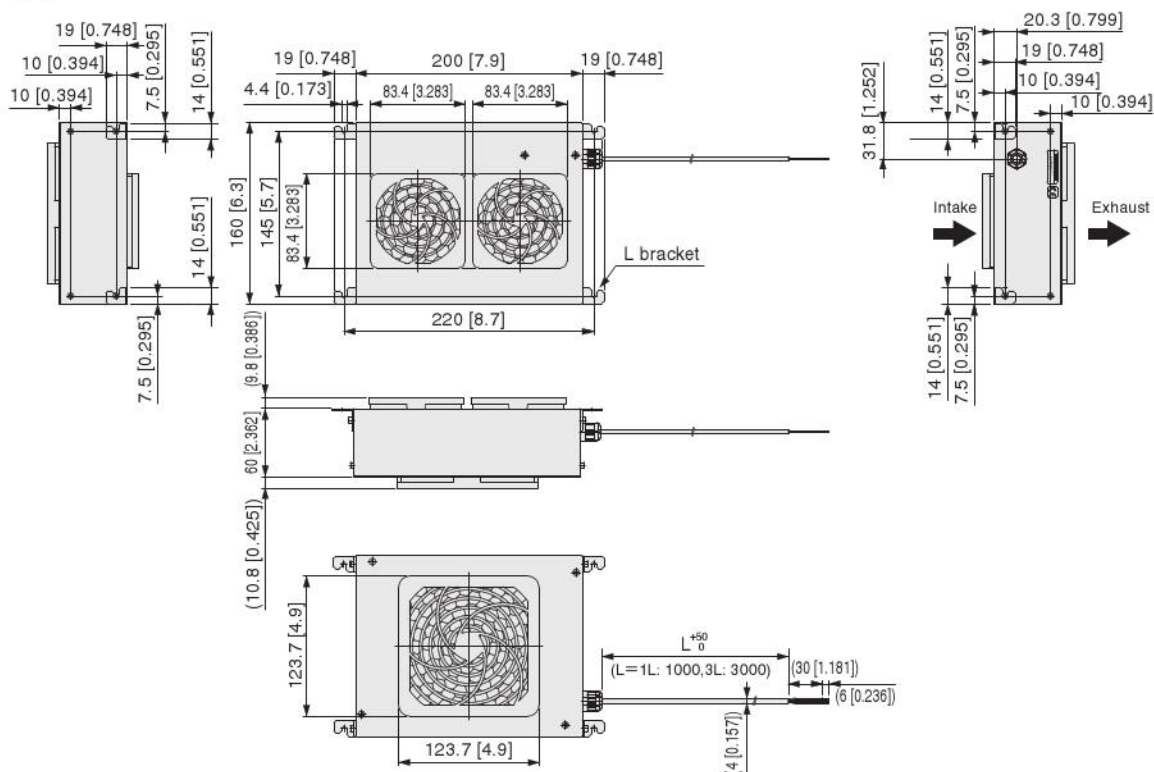

Dimensions (mm [in.])

Nozzle ϕ 2

● DTY-NZW-PP02

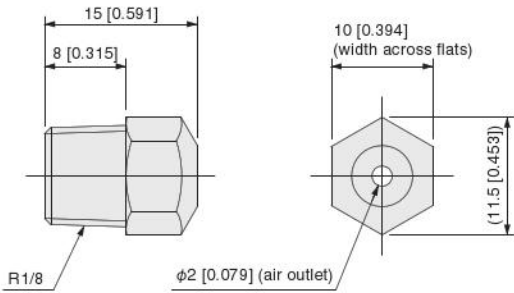

Nozzle ϕ 3

● DTY-NZW-PP03

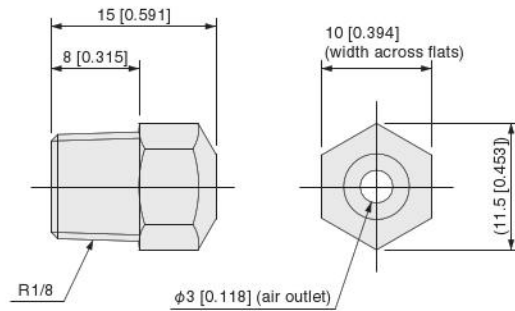

Nozzle ϕ 4

● DTY-NZW-PP04

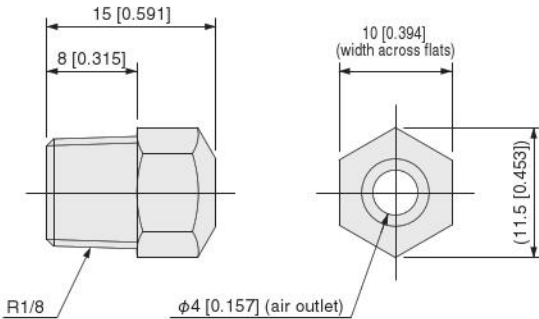

Shower nozzle 60°

● DTY-NZW-SW60

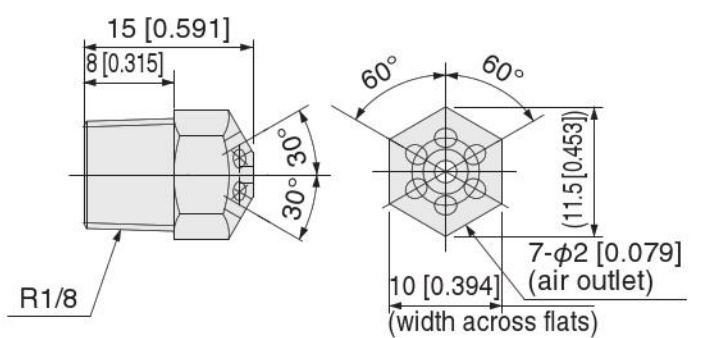

Shower nozzle 90°

● DTY-NZW-SW90

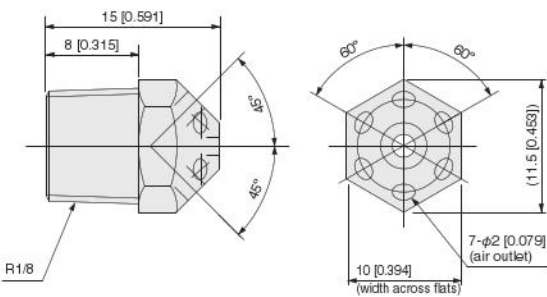

Flat nozzle

● DTY-NZW-FT01

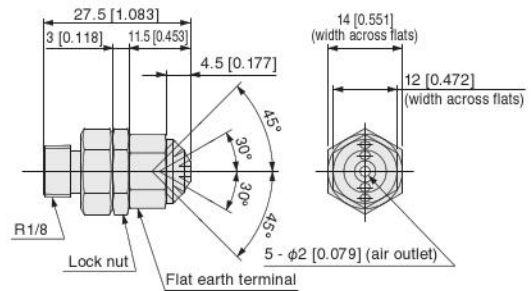

Nozzle joint

● DTY-NZW-NJ01

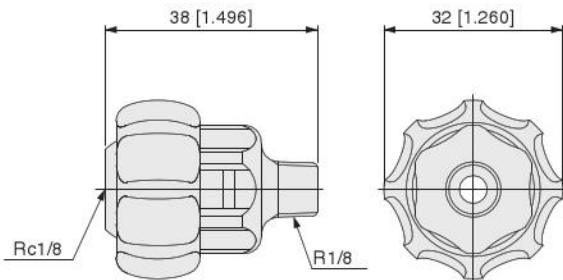

L bracket

● DTY-ZBRL-WB

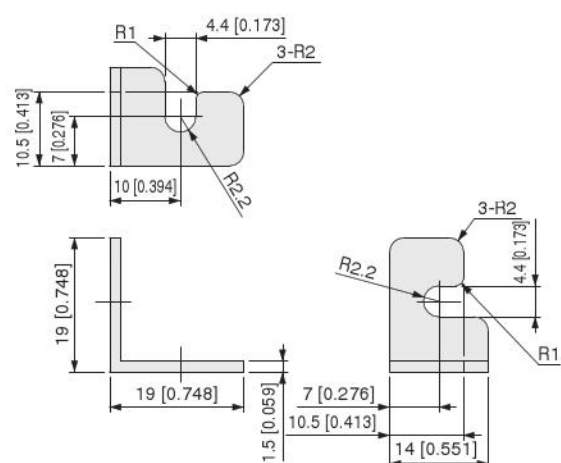

Dimensions (mm [in.])

Power cable

● DTY-ZDW-□

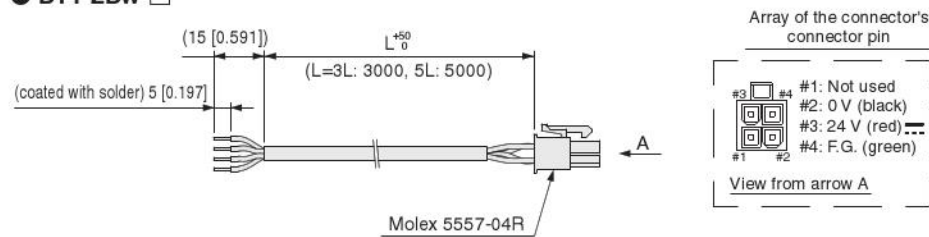

AC adaptor

● DTY-ZPS4

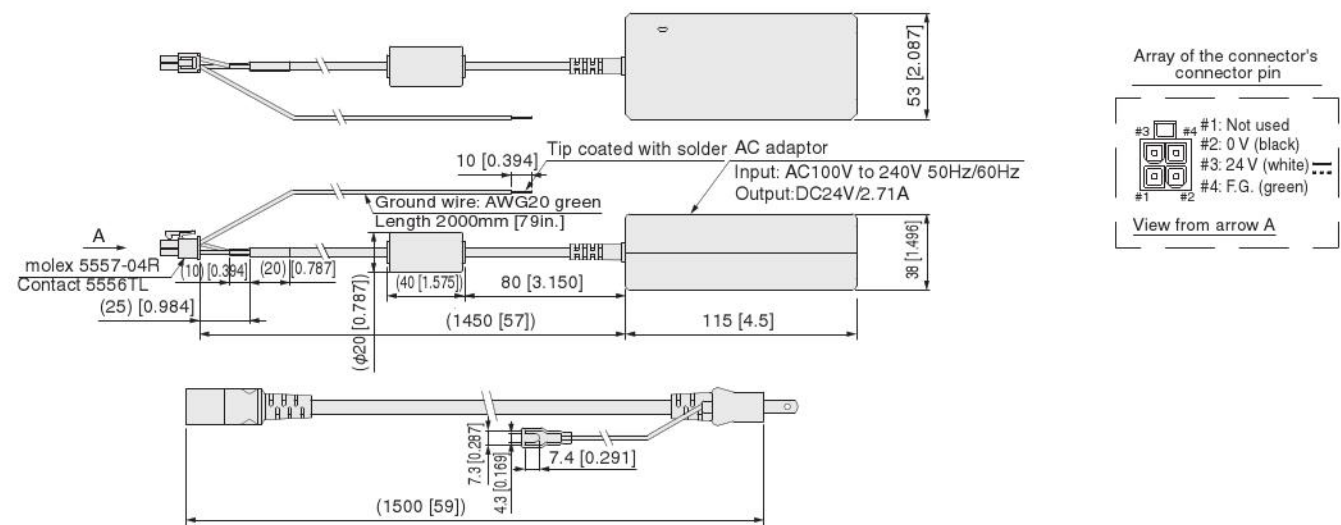

Communication cable (for upper controller)

● DTY-EPP-CG-□

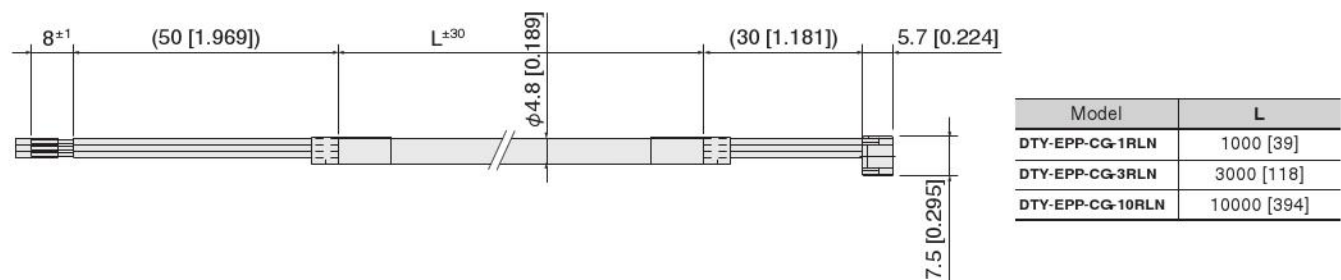

Communication cable (for daisy chain)

● DTY-EPP-CG-□

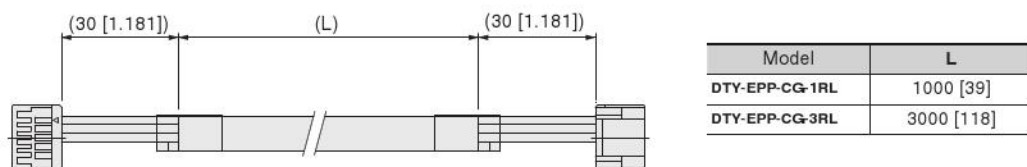

Dimensions (mm [in.])

USB-RS485 converter

● IBM2A-H1-□

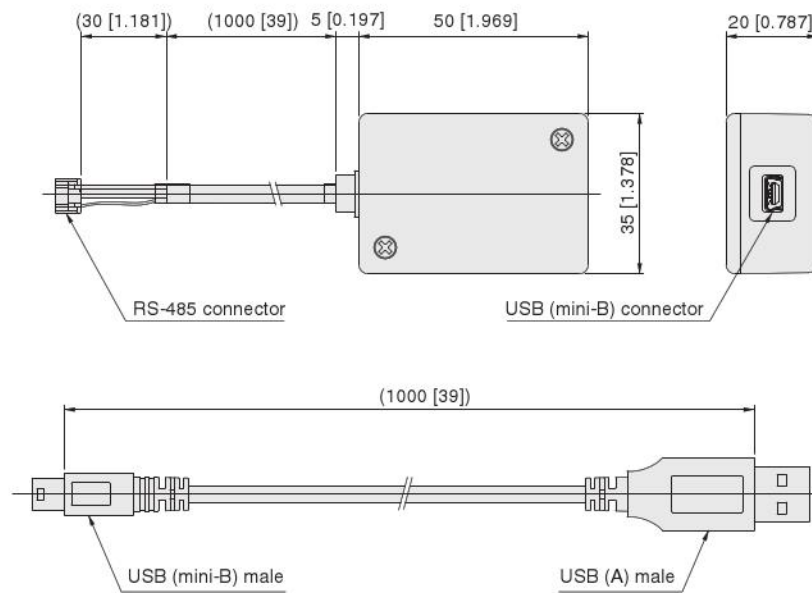

Termination resistance connector

● IBFL-K-TR

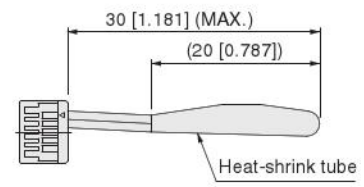

Dimensions (mm [in.])

Box (equivalent to A4 size)

● DTY-ZBW01-S

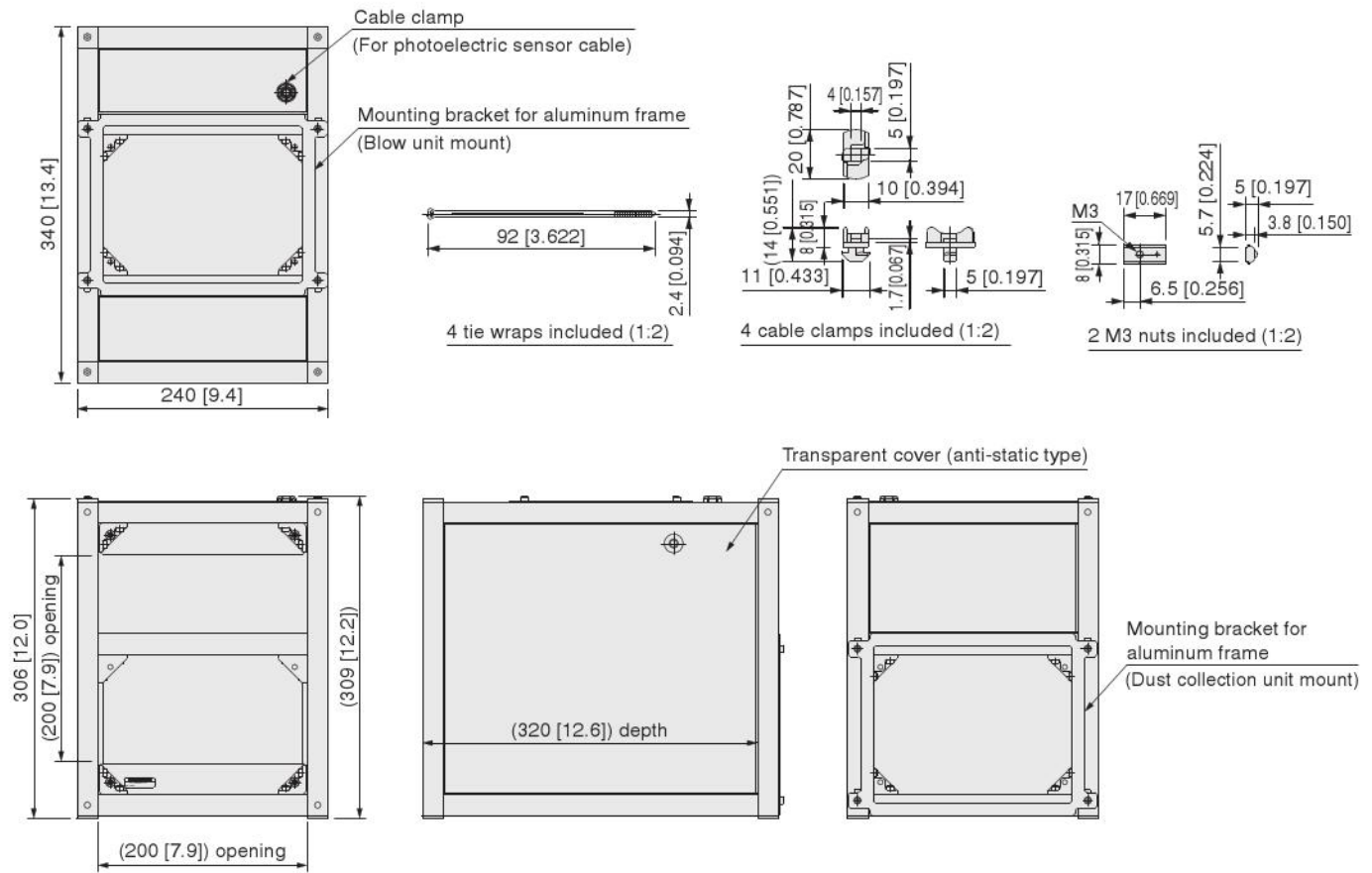

Box (equivalent to A3 size)

● DTY-ZBW01-L

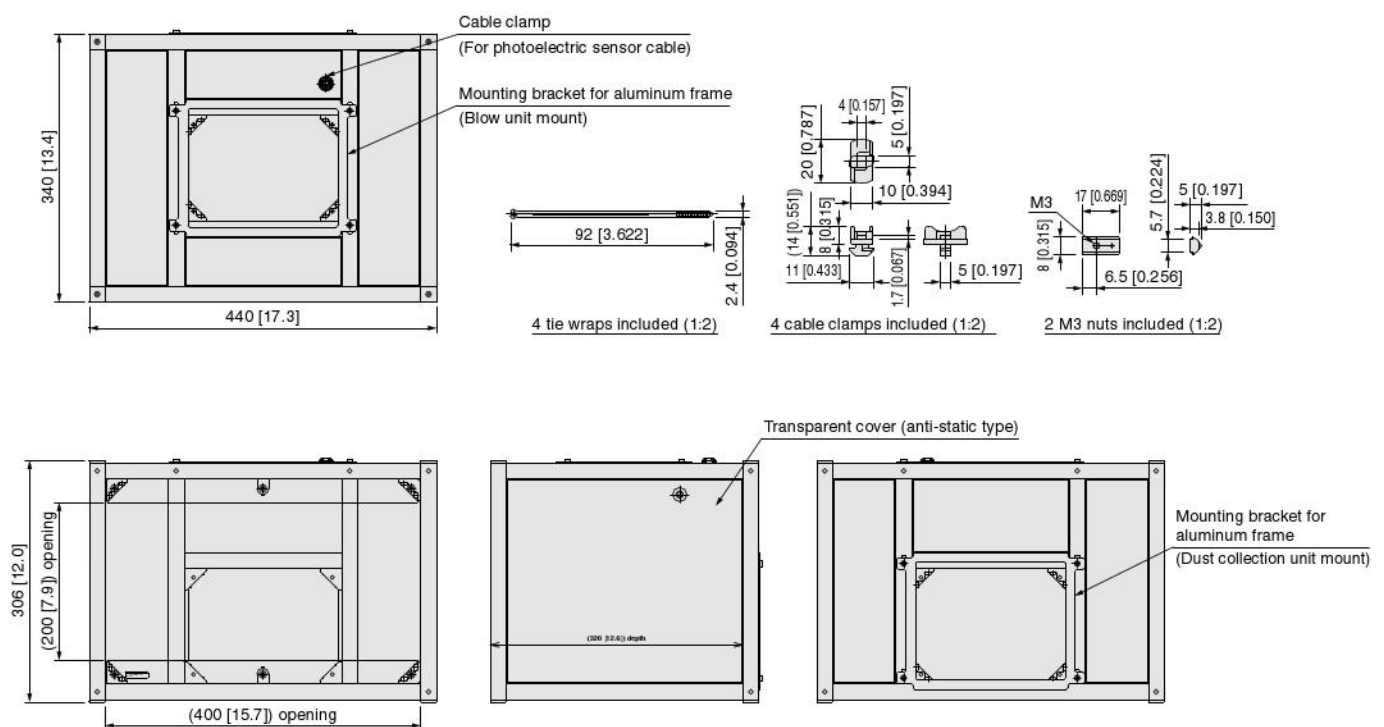

Mounting bracket for aluminum frame

● DTY-ZBRA-WB

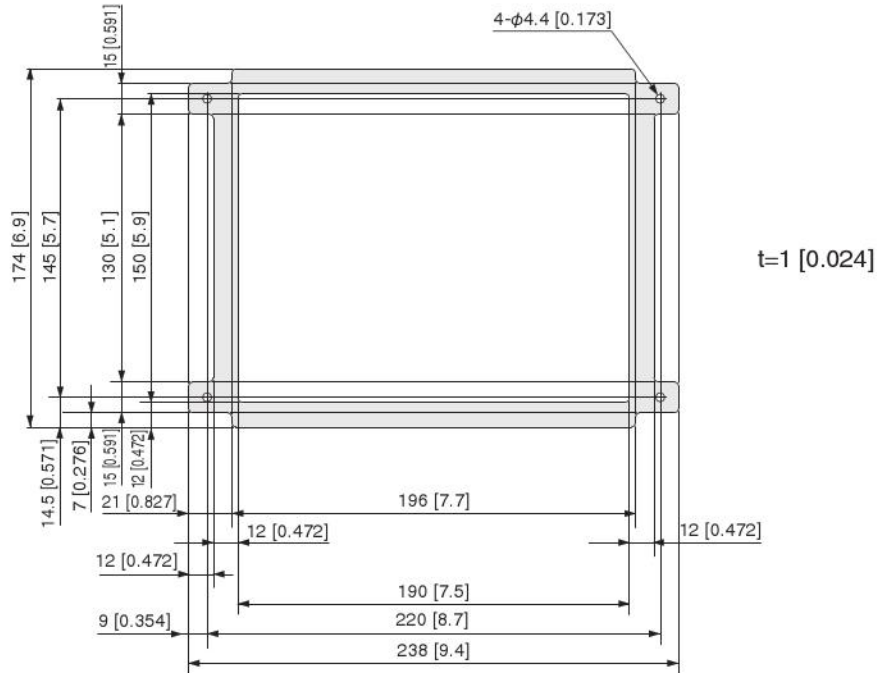

Mounting bracket for aluminum frame duct

● DTY-ZBRB-WB

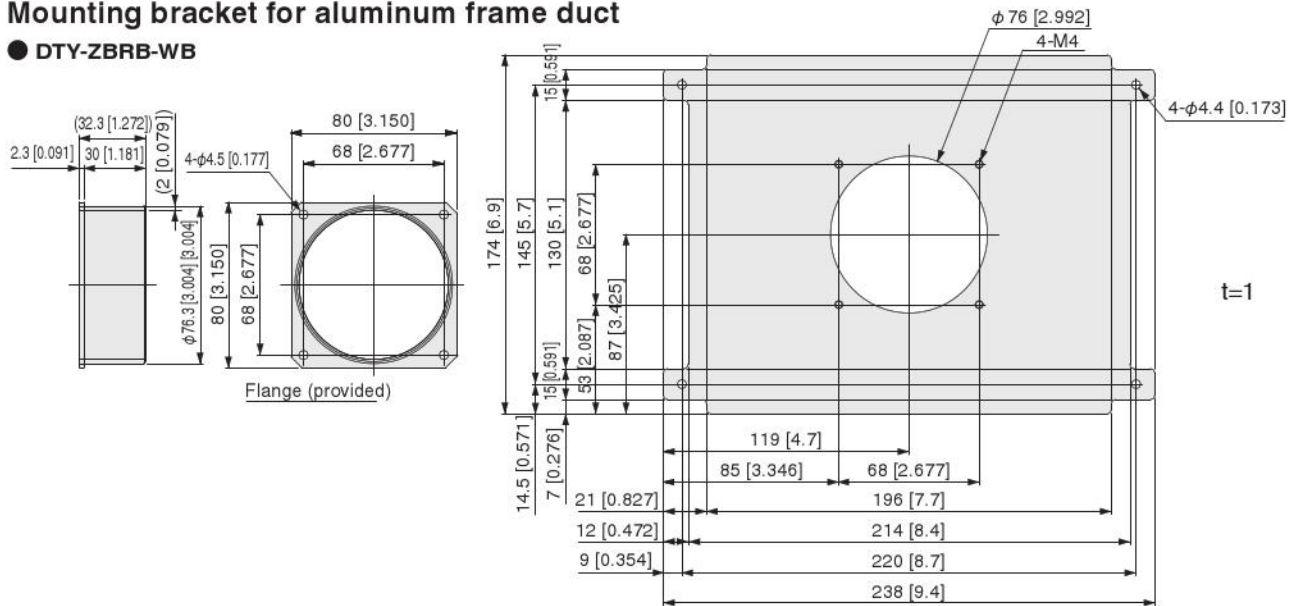

Nut for aluminum frame (M3)

● DTY-ZNW-M3

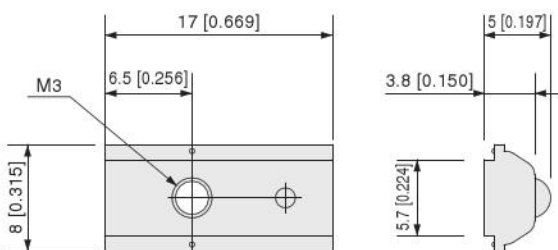

Nut for aluminum frame (M4)

● DTY-ZNW-M4

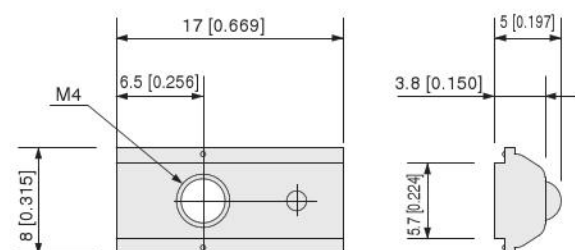



DTY-WBM01-S



DTY-WBM01-L

Specifications

Model	DTY-WBM01-S		DTY-WBM01-L	
Input voltage	V	24 VDC ±5%		
Consumption current	A	Max: 1.6 (when dust collection fan is running: Max: 2.6)		
Built-in ionizer		DTY-ELK01 (1 unit)		
Workpiece detection distance (photoelectric sensor) mm [in.]		50 to 500 [1.969 to 19.7]		
Ion balance ^{Note 1}	V	±15 (standard nozzle, set pressure 0.5 MPa [73 psi], 50 mm [1.969 in.] from tip of nozzle)		
Static charge elimination time ^{Note 1}	sec	1 (1000V→100V, 0.5 MPa [73 psi], 50 mm [1.969 in.])		
Medium		Air (clean air that contains no moisture or oil)		
Operating pressure range	MPa [psi]	0.2 to 0.7 [29 to 102]		
Ion air set pressure range	MPa [psi]	0.05 to 0.5 [7 to 73]		
Port size		φ8 [0.315] Quick fitting		
Air blowing time	sec	0.5 to 10, continuous (rotary switch, 16 points) (sensor off delay during continuous operation: 0.1 to 3.0)		
Intermittent blowing frequency	Hz	1, 2, 3, 4, 6, 8, 10, continuous (non intermittent) (rotary switch, 10 points, including 2 user settings areas)		
Switch		Power on/off Count ionizer discharge time, On: Enabled/Off: Disabled Count number of valve operations for blowing: On: Enabled/Off: Disabled		
Display		POWER: (green, power), ALM: (red, abnormal), MAINT: (yellow, maintenance) ION BLOW: (blue, blowing), EPS: (yellow, electrostatic potential sensor judging), DUST: (red/green/blue, state of dust sensor)		
Nozzle (only when -NZW is selected)		Shower type 60°: 1, Pinpoint type φ2: 2 (with nozzle joints)		
Consumed air flow ^{Note 2}	ℓ/min [ft ³ /min]	Ion air side: 170 (ANR) [6.0 (SCFM)], air blowing side: 330 (ANR) [11.7 (SCFM)]		
Dust collection fan exhaust flow rate	ℓ/min [ft ³ /min]	2000 [71]		
Communication		RS485 communication		
Number of communication connections	Units	15		
Usage environment		Indoor 0 to 40°C [32 to 104°F], 15 to 65% RH (with no condensation)		
Weight	kg [lb]	7.5 [16.535] (with nozzles/with dust sensor/excluding power source)	9.5 [20.944] (with nozzles/with dust sensor/excluding power source)	
Accessories		1 micro-driver, and instruction manual		

Note 1: Measurements are made using Koganei measurement methods and conditions.

Note 2: Nozzles: Pinpoint is φ2 [0.079]×2 locations, shower is 60°/when throttle valve is fully open; feed pressure is 0.7 MPa [102 psi]; and set pressure for ion air regulator is 0.5 MPa [73 psi]

Note 3: Only the air blow operates intermittently. The ion air function does not do intermittent blowing.

* The product uses grease on internal sliding parts.

Specifications for external output

Model	DTY-WBM01-S		DTY-WBM01-L	
External input/output	Output	ALARM: (abnormal output), CHECK: (ionizer discharge abnormal output), MAINT: (maintenance period output), EPS: (electrostatic potential sensor judgment output) DUST: (dust sensor judgment output), END: (blow operation end output), VAC START: (external device operation output) (NPN open collector 24 VDC/Max 50 mA)		
	Input	STOP: (operation stop input), START (operation start input), ZC: (electrostatic potential sensor calibration input) (input current 4.8 mA/at 24 VDC)		

Order Codes

● Box type

DTY - WBM 01 -

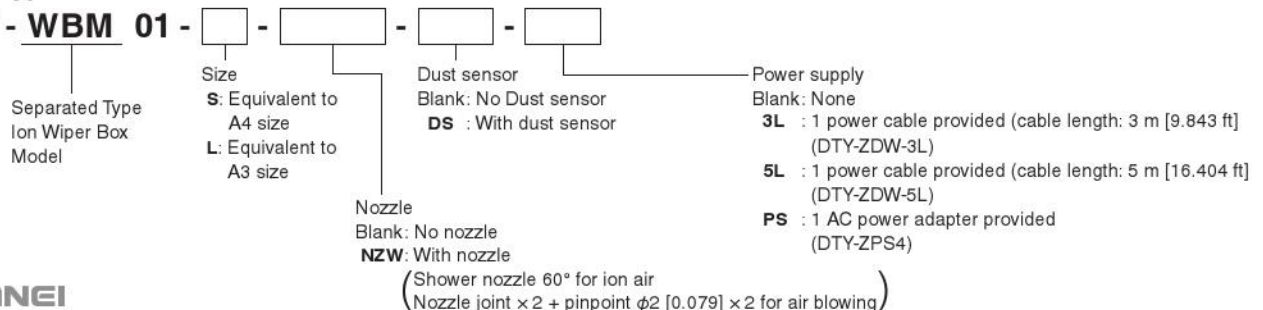

Dimensions (mm [in.])

Box model (equivalent to A4 size)

● DTY-WBM01-S-□-□-□

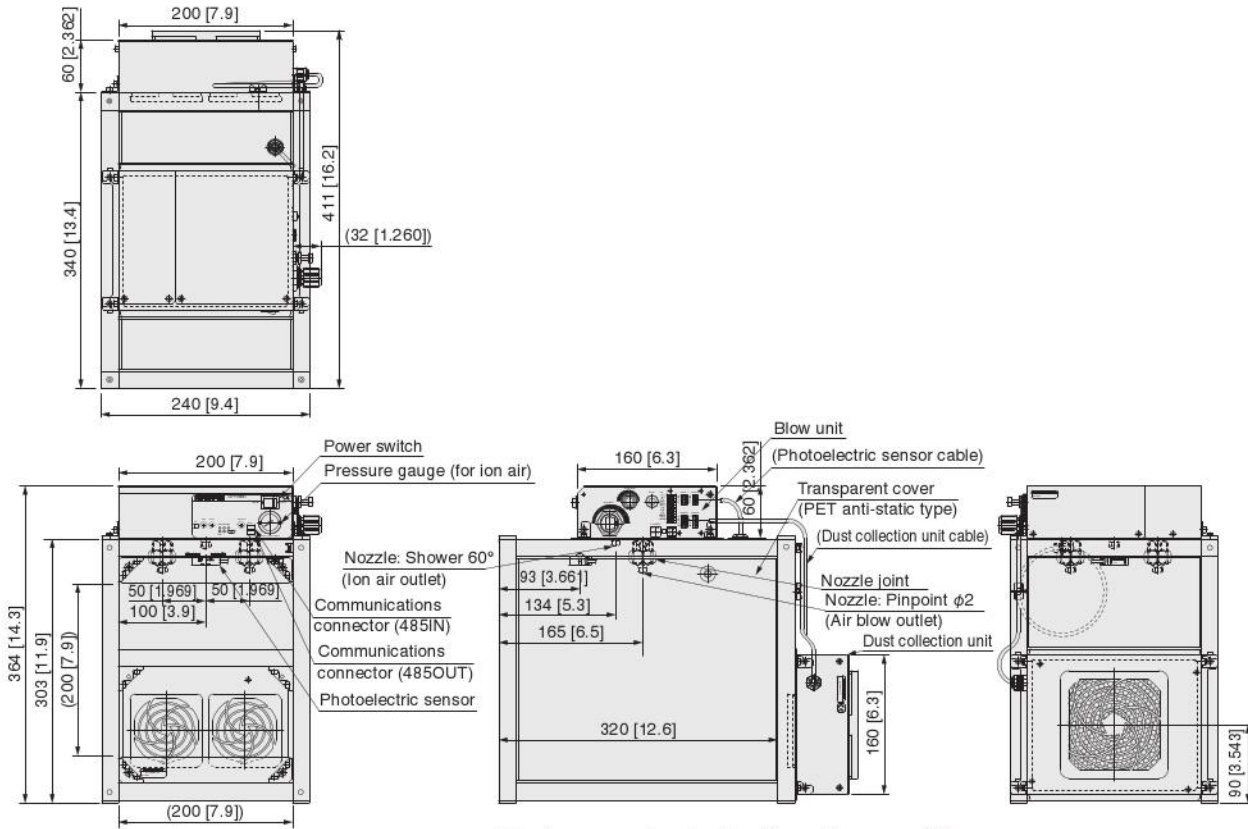

* For the names of parts of the blow unit, see page 15.

Box model (equivalent to A3 size)

● DTY-WBM01-L-□-□-□

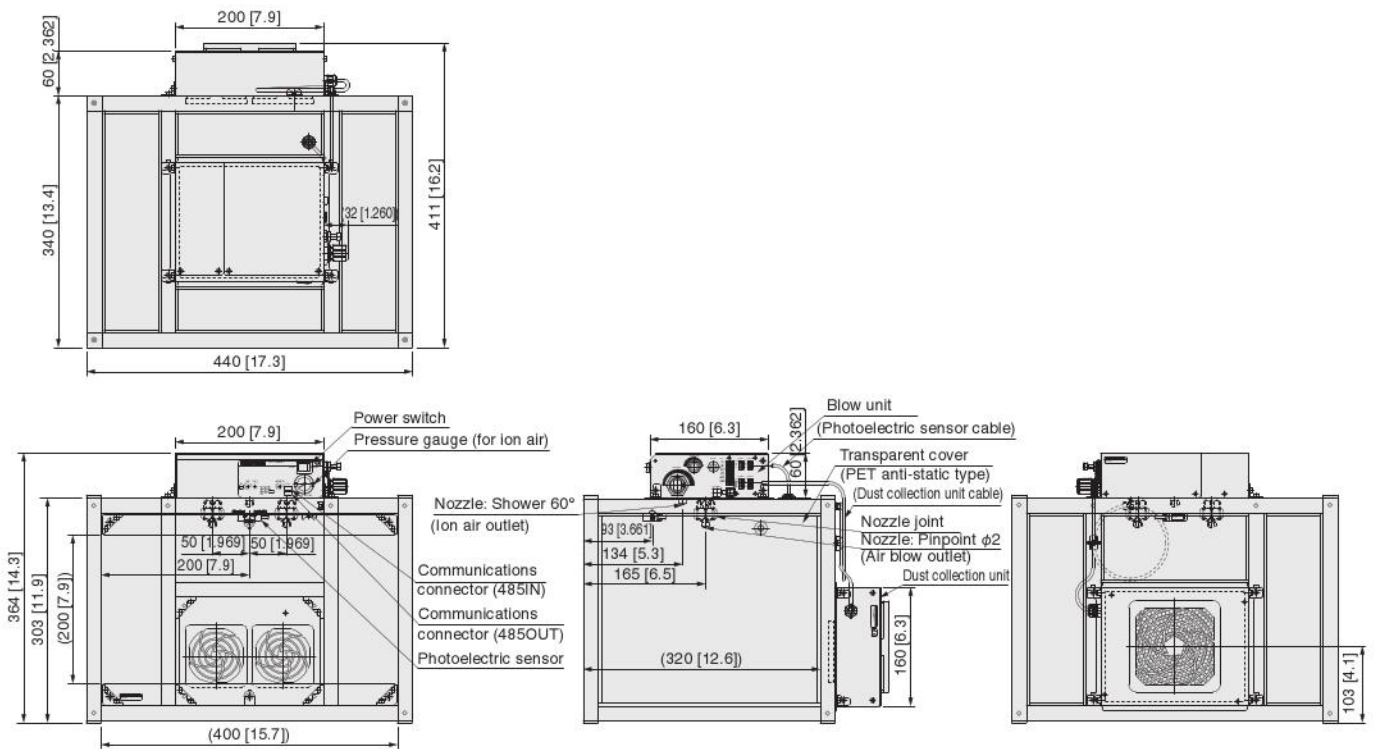

* For the names of parts of the blow unit, see page 15.

Photoelectric sensor

Specifications

Model		DTY-ZSP1L-WB	DTY-ZSP3L-WB
Input voltage	V	24 VDC ±10%	
Consumption current	mA	Max:50	
Sensing method		Reflective type	
Detection distance ^{Note 1}	mm [in.]	50 to 500 [1.969 to 19.7]	
Light source (luminescence wavelength)		Infra-red (940 nm)	
Control output	Output method	Transistor output, NPN open collector (with overcurrent protection)	
	Output voltage	V	24 VDC ±10%
	Output Current	mA	Max:50
	Leakage current when off	mA	Max:0.1
	Residual voltage when on	V	Max: 0.3/at 5 mA, max: 1/at 50 mA
Switch	SW 1	Switch to change modes	
	SW 2	Switch to set output at detection (no inversion/inversion)	
	L-H	Setting trimmer (detection distance)	
Usage environment		Indoor 0 to 40°C [32 to 104°F], 15 to 65% RH (with no condensation)	
Cable length	m [ft]	1 [3.281]	3 [9.843]
Weight	g [oz]	30 [1.058] (including cable)	75 [2.646] (including cable)
Accessories		2 installation screws, owner's manual	



Note 1: According to Koganei testing conditions

Order Codes

● Photoelectric sensor

DTY - ZSP **-WB**

Cable length
1L: 1 m [3.281 ft]
3L: 3 m [9.843 ft]

Dimensions (mm [in.])

Photoelectric sensor

● DTY-ZSP -WB

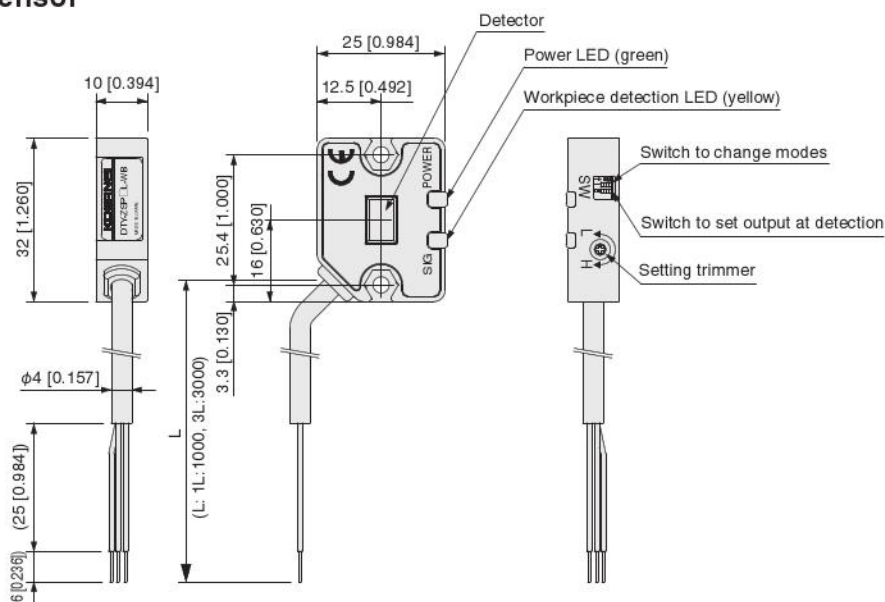

Electrostatic Potential Sensor

Specifications

Model	DTY-EPS01-EA	
Input voltage	V	24 VDC ±10%
Consumption current	mA	max 50
Indicator light	Power LED (green): Lights when power is on	
	Measurement mode display LED (blue): Off in standard mode; lights in high voltage mode; flashes in ion balance mode	
	Indicator LED (red) for abnormalities: Lights when over range or abnormality occurs in main unit	
Measurement distance	mm [in.]	6 to 100 [0.236 to 3.9]
Measurement range	mm [in.]	φ20 to φ400 [0.787 to 15.7]
Accuracy ^{Note 1}		±5% F.S.
Data output cycle	ms	10 Smoothing: 50, 100, 200, 500, 1000 (depending on the setting)
Settings mode		Ion balance mode/Standard mode/High voltage mode
Button settings		1 (Measurement mode switch/Zero calibration)
Communication		RS485 communication
Temperature characteristics		+0.5% F.S./°C or under (0 to 40°C [0 to 104°F], standard of 25°C [77°F])
Usage environment		0 to 40°C [32 to 104°F]/less than 65% RH (no condensation, non-freezing)
Storage environment		-20 to 60°C [-4 to 140°F] (non-condensation, non-freezing)
Case material		Conductive ABS plastic
Weight	g [oz]	13 [0.459] (cable not included)
Accessories		1 L bracket (2 mounting screws, 2 flat washers) owner's manual



Order Codes

● Electrostatic Potential Sensor

DTY - EPS01 - EA -

- Electrostatic Potential Sensor
- Relay cable
- 3LWB:** Relay cable 3 m [9.843 ft]
1 attached
- 10LWB:** Relay cable 10 m [32.808 ft]
1 attached

● Relay cable

DTY - EPP - CE -

- Cable length
- 3L:** 3 m [9.843 ft]
- 10L:** 10 m [32.808 ft]

● Component bracket

DTY - EPP - BR2

Note 1: Under Koganei measurement conditions.

Remark: If no measurement conditions are specified, the temperature range is 25°C [77°F].

* For handling instructions and precautions for electrostatic potential sensors, refer to page 149 in Catalog No. R0006 "Static Electricity Removing Units and Ionizers".

Dimensions (mm [in.])

Electrostatic Potential Sensor

● DTY-EPS01-EA-

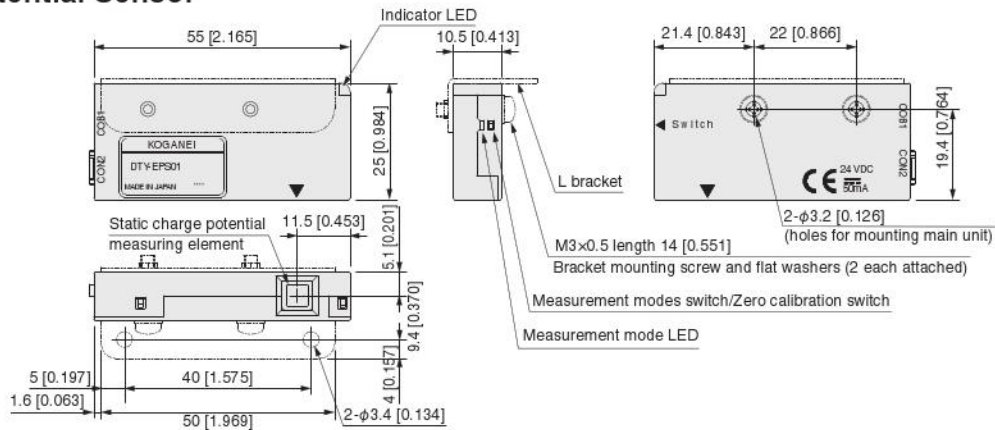

Relay cable

● DTY-EPP-CE-

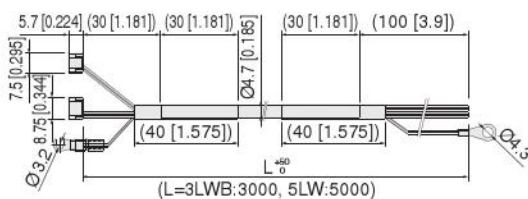

Component bracket

● DTY-EPP-BR2

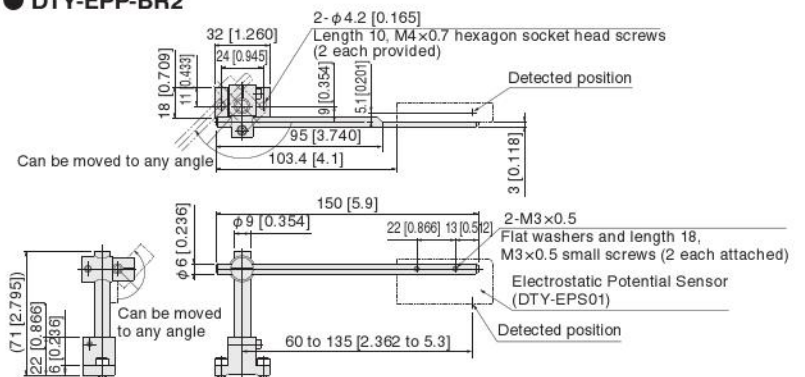

MEMO

A series of horizontal dashed lines for writing.

Limited Warranty

KOGANEI CORP. warrants its products to be free from defects in material and workmanship subject to the following provisions.

Warranty Period The warranty period is 180 days from the date of delivery.

Koganei Responsibility If a defect in material or workmanship is found during the warranty period, KOGANEI CORP. will replace any part proved defective under normal use free of charge and will provide the service necessary to replace such a part.

Limitations ● This warranty is in lieu of all other warranties, expressed or implied, and is limited to the original cost of the product and shall not include any transportation fee, the cost of installation or any liability for direct, indirect or consequential damage or delay resulting from the defects.

● KOGANEI CORP. shall in no way be liable or responsible for injuries or damage to persons or property arising out of the use or operation of the manufacturer's product.

● This warranty shall be void if the engineered safety devices are removed, made inoperative or not periodically checked for proper functioning.

● Any operation beyond the rated capacity, any improper use or application, or any improper installation of the product, or any substitution upon it with parts not furnished or approved by KOGANEI CORP., shall void this warranty.

● This warranty covers only such items supplied by KOGANEI CORP. The products of other manufacturers are covered only by such warranties made by those original manufacturers, even though such items may have been included as the components.

The specifications are subject to change without notice.

URL <http://www.koganei.co.jp>

E-mail: overseas@koganei.co.jp



KOGANEI CORPORATION

OVERSEAS DEPARTMENT

3-11-28, Midori-cho, Koganei City, Tokyo 184-8533, Japan
Tel: 81-42-383-7271 Fax: 81-42-383-7276

KOGANEI International America, Inc.

48860 Millmont Drive, Suite 108C Fremont, CA 94538, U.S.A
TEL: (+1)510-744-1626
FAX: (+1)510-744-1676

SHANGHAI KOGANEI INTERNATIONAL TRADING CORPORATION

RM2606-2607, Tongda Venture Building NO.1 Lane 600, Tianshan Road, Shanghai, China
TEL: (+86)021-6145-7313
FAX: (+86)021-6145-7323

TAIWAN KOGANEI TRADING CO.,LTD

Rm.2, 16F, No88, Sec.2, Zhongxiao E. Rd., ZhongZheng Dist., Taipei City 10050, Taiwan (ROC)
TEL: (+886)02-2393-2717
FAX: (+886)02-2393-2719

KOGANEI KOREA CO., LTD

A-3001, Heungdeok IT Valley Bldg., Heungkeok 1-ro, 13, Giheung-gu, Yongin-si, Gyeonggi-do, 446-908, KOREA
TEL: (+82)31-246-0414
FAX: (+82)31-246-0415

KOGANEI (THAILAND) CO., LTD

555 Rasa Tower I, Unit 1207, 1202, 12th Floor, Phaholyothin Road, Chatuchak, Chatuchak, Bangkok 10900, Thailand
TEL: (+66)02-513-1228
FAX: (+66)02-513-1232

KOGANEI ASIA PTE. LTD.

69 Ubi Road 1, #05-18 Oxley Bizhub Singapore 408731
TEL: (+65)6293-4512
FAX: (+65)6293-4513