

Static Electricity Removal Unit Ionizer Ion Polarity Control Type DTY-BX01 Series

Compact body

Body size 25 × 35 mm [0.984×1.378 in]

**High voltage wiring not required,
with built-in potential sensor**

All-in-one unit ionizer



Ion Polarity Control Type Ionizer DTY-BX01 Series Features

- High-voltage wiring and controller are not required. All-in-one unit ionizer has high-voltage power source and built-in potential sensor.
- Compact body is just 25 mm × 35 mm [0.984×1.378 in]
- Uses potential sensor to adjust positive or negative ion output for ionizer.
- Dedicated monitors used to constantly monitor electrostatic charge

Compact high-voltage power source built in Compact body fits anywhere

Body size is 25 × 35 mm [0.984×1.378 in]
Compact body allows for flexible mounting options in any layout.
No high-voltage cables and no separate controller installation required.

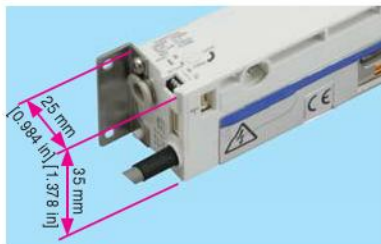

Connect potential sensor for Faster Decay Times

Ion polarity adjustments can be made based on output of potential sensor to eliminate static charge faster than standard ionizers.
Potential sensor checks surface or part after ionizer used to ensure proper static removal.



Potential sensor



Monitor

Two unit lengths available

200 mm [7.87 in], 400 mm [15.75 in]

Compressed air type and fan unit type available in either length.



200 mm [7.87 in]

Fan unit type



400 mm [15.75 in]

Fan unit type

Select from 3 static charge removal modes to match your application Ion polarity control mode, pulse mode, and high-frequency mode

Select the mode that meets your goals.

- **Ion polarity control** static charge removal uses potential sensor for high speed removal of static charge.
- **Pulse** static charge removal uses large fluctuation in voltage but needs no sensor to remove static charge quickly.
- **High-frequency** static charge removal has small voltage fluctuation.

*See page ③ for variations and a table of the types of products that support the different static charge removal modes.

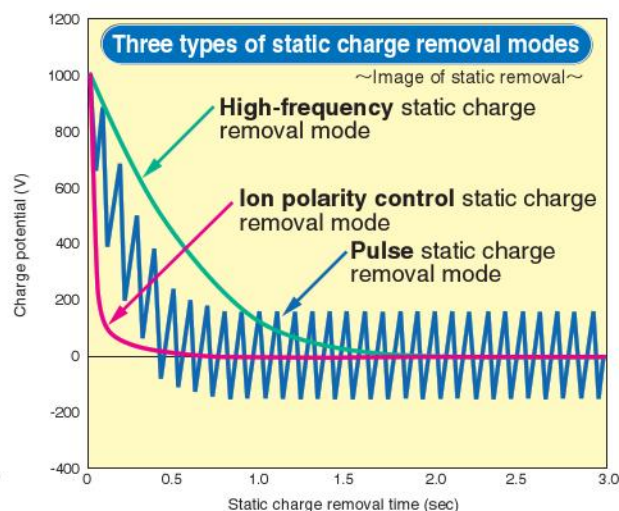

External potential sensor type Image of usage

Effectively remove static charge from moving objects, so you do not need to create a process to remove static electricity.

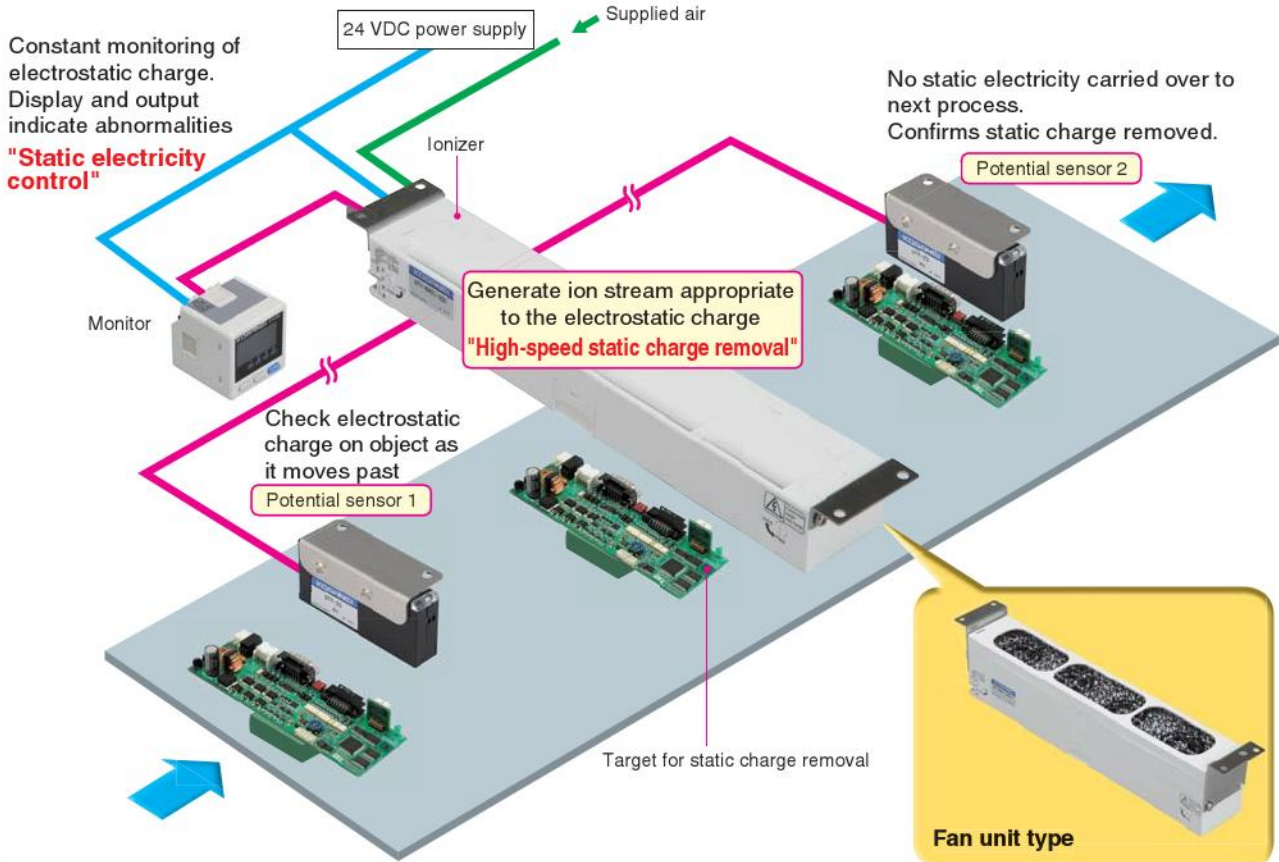

- Various settings on computer needed for high-speed static charge removal with sensors.
- Cable (DTY-ZTC-BX) to communicate with computer required.
- Output is from main unit only.

Select fan unit type to eliminate air pipes
 *It is not possible to change from a type that uses compressed air to a fan unit type.
 Select one or the other when you place your order.

Other features

Easy maintenance

Discharge needle unit can be removed so maintenance is easy.

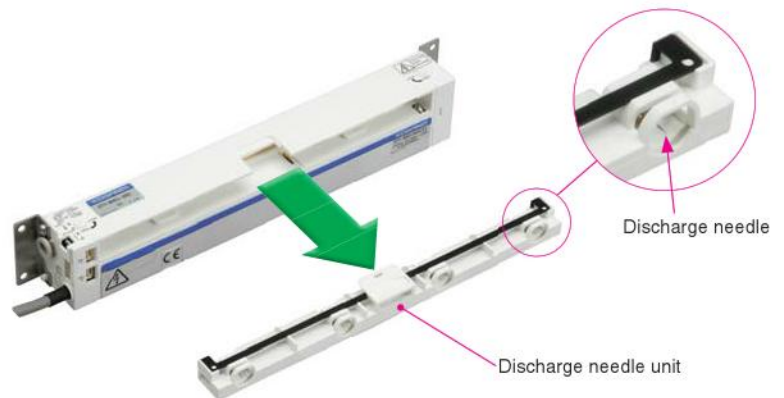

Free software download

Specialized support software (free) can be used to check electrostatic charges and set the ionizer on a computer so the monitor does not need to be used.

- Download the software from our homepage to use it.
- Compatible operating systems: Windows XP SP3 and later
- Hardware requirements: Monitor resolution SVGA (800 x 600) or higher
- Required software: Microsoft .NET Framework 4
- ★ Windows is a registered trademark of Microsoft Corporation.



(Image)

Variations

See page 4 for details about the static charge removal modes.

External potential sensor type

- Effective static charge removal from moving objects in ion polarity control static charge removal mode
- Possible to control static electricity using potential sensor
- High-speed static removal in pulse static charge removal mode even without using a potential sensor

<Variations>

- Length of main unit
200 mm [7.87 in]/400 mm [15.75 in]
- Ion delivery method
Compressed air/fan
- Low particle generation specifications
(compressed air type)

<Types of static charge removal mode>

- Ion polarity control static charge removal mode^{Note 1}
- Pulse static charge removal mode^{Note 2}
- High-frequency static charge removal mode^{Note 2}

Note 1: A computer is needed to set the ion polarity control static charge removal mode.
2: Potential sensor 1 is not used in pulse or in high-frequency static charge removal mode.

Used to do various settings and to check electrostatic charge.

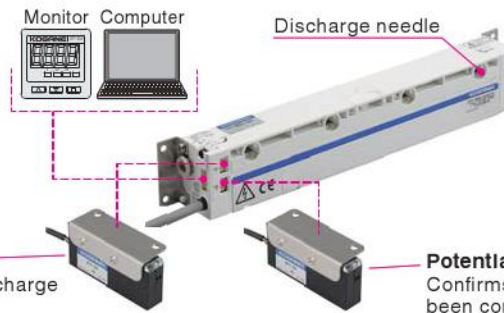

Potential sensor 1

Checks the electrostatic charge on an object.
The volume of ions generated is controlled based on this electrostatic charge. Required for ion polarity control mode.

Potential sensor 2

Confirms that static charge has been completely removed.

*Photo shows DTY-BX01-200

Integrated potential sensor type

- Effective static charge removal from stationary objects in ion polarity control static charge removal mode
- Possible to control static electricity using potential sensor

<Variations>

- Length of main unit
200 mm [7.87 in]/400 mm [15.75 in]
- Ion delivery method
Compressed air/fan
- Low particle generation specifications
(compressed air type)

<Types of static charge removal mode>

- Ion polarity control static charge removal mode

*Distance from ionizer to target must be from 50 to 150 mm [1.97 to 5.91 in].

*If potential sensors are used, they must be located at least 500 mm [19.69 in] from the ionizer.

Used to do various settings and to check electrostatic charge.

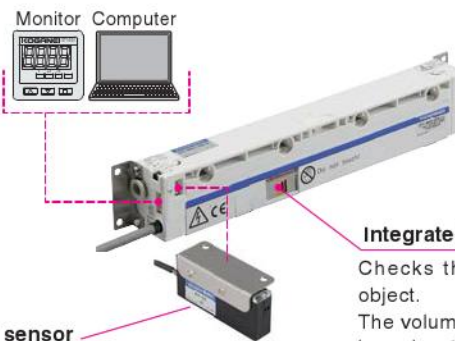

Integrated potential sensor

Checks the electrostatic charge on an object.
The volume of ions generated is controlled based on this electrostatic charge.

Potential sensor

Confirms that static charge has been completely removed.

*Photo shows DTY-BX01-200-B

Simple types

- Just install wiring and piping to start operating. Compact and no settings needed
- High-frequency AC format static charge removal has small voltage fluctuation

<Variations>

- Length of main unit
200 mm [7.87 in]/400 mm [15.75 in]
- Ion delivery method
Compressed air

<Types of static charge removal mode>

- High-frequency static charge removal mode

*Potential sensor and monitor cannot be installed.



*Photo shows DTY-BX01-200-N

Table of functions for each type

Type	Function	Static charge removal mode			Ion delivery method		Low particle generation specifications ^{Note 1}	Sensor for checking electrostatic charge ^{Note 2}	Sensor for confirming static charge has been removed ^{Note 2}
		Ion polarity control	Pulse ^{Note 3}	High frequency ^{Note 3}	Compressed air	Fan			
External potential sensor type		○	○ ^{Note 3}	○ ^{Note 3}	○	○	○	External	External
Integrated potential sensor type		○	—	—	○	○	○	Integrated	External
Simple types		—	—	○	○	—	—	—	—

Note 1: The fan unit type does not have a low particle generation specification setting.

2: To use external potential sensors, specify them as options when ordering the main unit, or purchase them as separate options.

3: External potential sensor 1 is not used.

Explanation of different static charge removal modes

High-frequency static charge removal mode

The high-frequency AC format generates positive and negative ions in a very short cycle to supply a good balance of ions to the target.

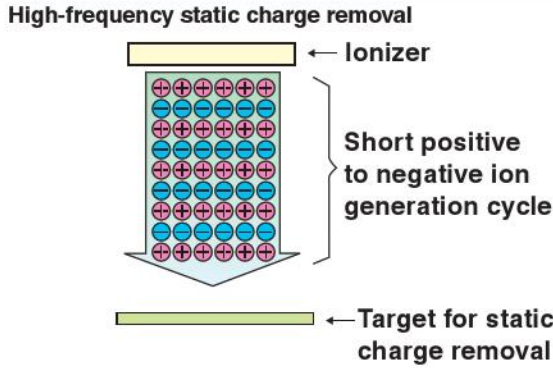

Pulse static charge removal mode

Generates a large volume of positive and negative ions at a low frequency. Static charge removal can be faster than high-frequency static charge removal mode. Voltage fluctuation* is larger than in high-frequency static charge removal mode.

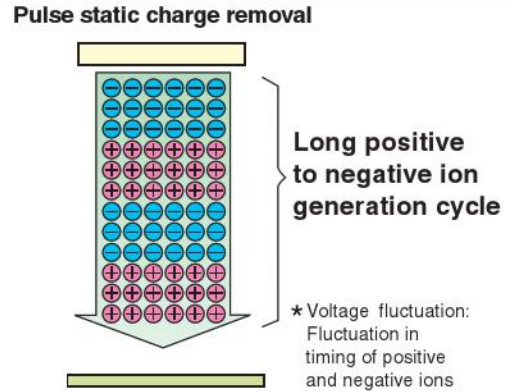

Ion polarity control static charge removal mode <Using a potential sensor to control ions generated>

When the electrostatic charge on the target is small, ions are generated in a high-frequency AC format to remove the static charge. When the potential sensor detects a target with a large electrostatic charge, ions with the opposite polarity are quickly supplied to the target to remove the static charge according to the size of the electrostatic charge. When the electrostatic charge becomes small, ion generation returns to the high-frequency AC format.

Image of static removal when there is a large positive electrostatic charge

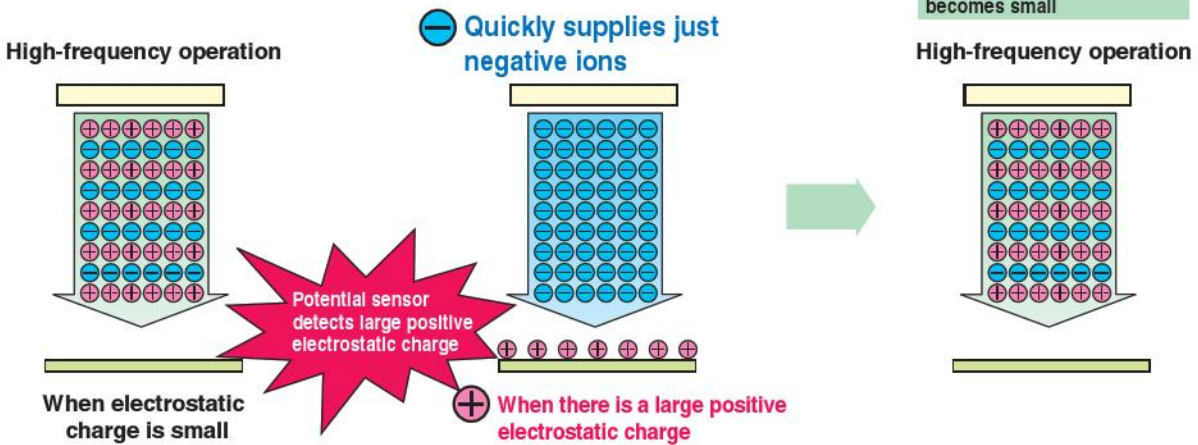
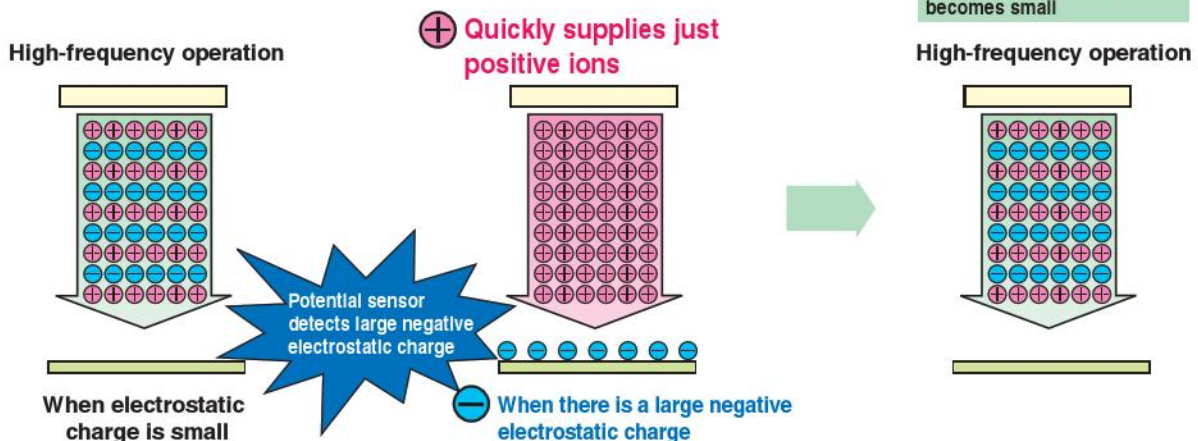

Image of static removal when there is a large negative electrostatic charge



Examples of the main uses of external potential sensor types

● Static charge removed from objects as they are moving

Ion polarity control static charge removal mode

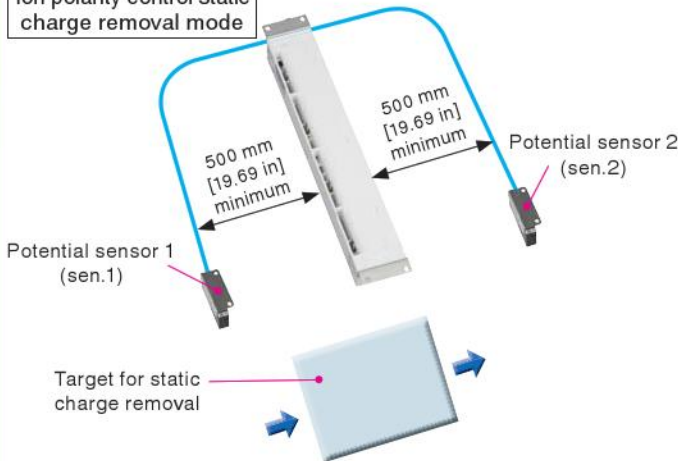

Effective static charge removal while object is moving.

Potential sensor 1 checks the electrostatic charge on an object



Ionizer generates perfect ion stream to eliminate static charge



Potential sensor 2 confirms that static charge has been completely removed, if it is outside the set value, an LED on the ionizer lights and a notification signal is output.

- Various settings must be done on a computer for ion polarity control static charge removal.
- You must provide a cable (**DTY-ZTC-BX**) to communicate with the computer separately.
- Locate ionizers and potential sensors so there is at least 500 mm [19.69 in] between them.
- Position the potential sensor as close as possible to the target. (Recommended working distance: 50 mm [1.97 in])

● Effective static charge removal from stationary objects

Ion polarity control static charge removal mode

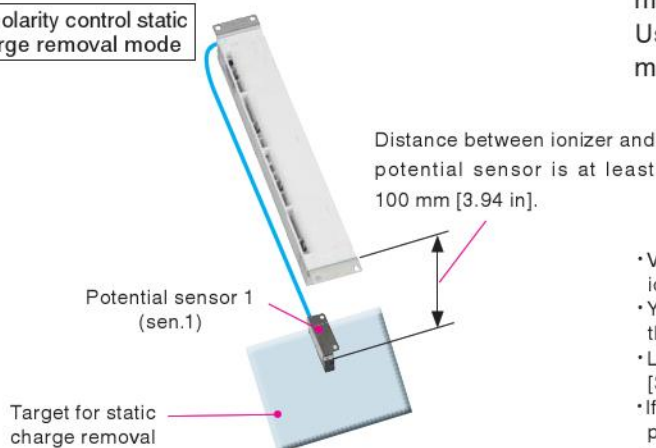

Effective static charge removal from stationary objects in ion polarity control static charge removal mode.

Use if distance from ionizer to target is more than 150 mm [5.91 in].

- Various settings must be done on the monitor or a computer for ion polarity control static charge removal.
- You must provide a cable (**DTY-ZTC-BX**) to communicate with the computer separately.
- Locate ionizers and potential sensors so there is at least 100 mm [3.94 in] between them.
- If the target is small or if the target is far from the sensor, then ion polarity control static charge removal may not operate correctly.
- Position the potential sensor as close as possible to the target. (Recommended working distance: 50 mm [1.97 in])

Examples of the main uses of integrated potential sensor types

● Effective static charge removal from stationary objects

Ion polarity control static charge removal mode

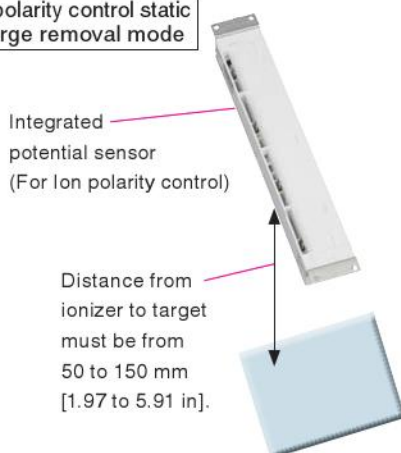

Effective static charge removal from stationary objects in ion polarity control static charge removal mode.

Use if distance from ionizer to target is in a range of 50 mm to 150 mm [1.97 to 5.91 in].

- Various settings must be done on the monitor or a computer for ion polarity control static charge removal.
- You must provide a cable (**DTY-ZTC-BX**) to communicate with the computer separately.
- Installed distance from ionizer to target must be from 50 to 150 mm [1.97 to 5.91 in].
- The integrated sensor is used to control polarity of ions. It cannot be used for checking after static charge has been removed.
- If the target is small or if the target is far from the sensor, then ion polarity control static charge removal may not operate correctly.
- Position the ionizer as close as possible to the target. (Recommended working distance: 50 mm [1.97 in])

Other examples of applications

External potential sensor type

Static charge removed from objects as they are moving

Ion polarity control static charge removal mode

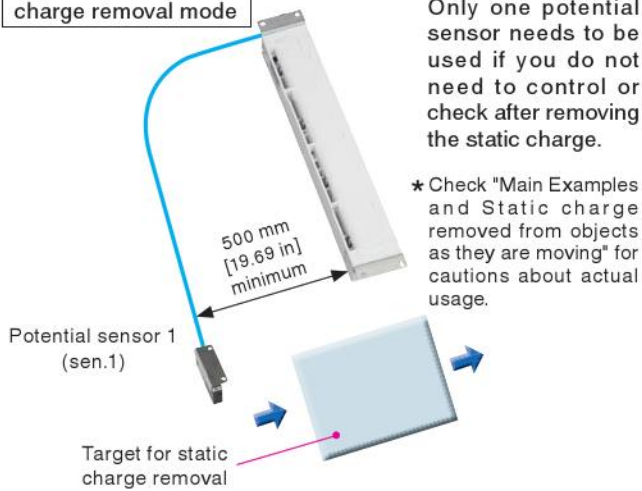

Moving or stationary targets

High-frequency static charge removal mode

When confirming electrostatic charge in the high-frequency static charge removal mode without controlling polarity of ions

Note: Potential sensor 1 is not used.

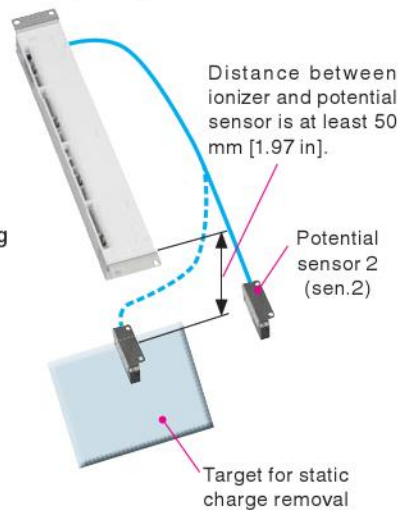

Moving or stationary targets

Pulse static charge removal mode

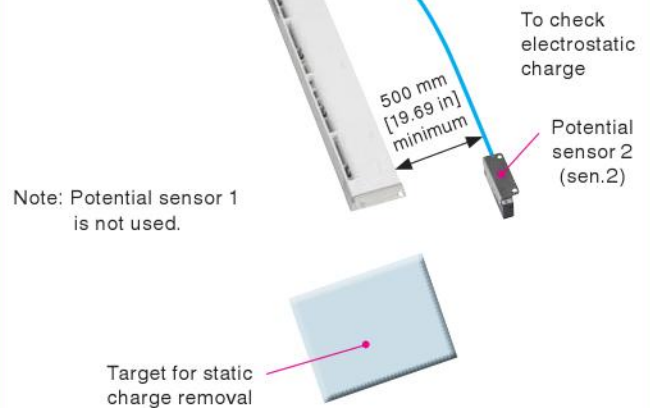

Integrated potential sensor type

Stationary targets

Ion polarity control static charge removal mode



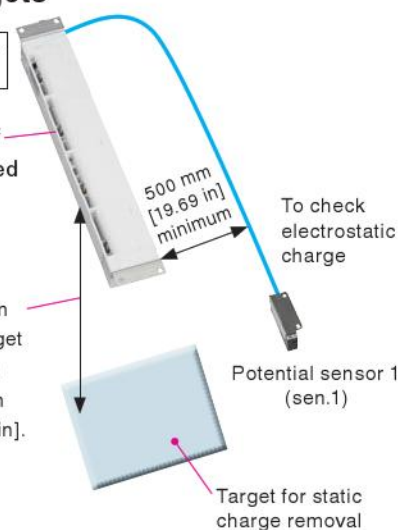

Control polarity of ions with integrated potential sensor

Distance from ionizer to target must be from 50 to 150 mm [1.97 to 5.91 in].



Before selecting and using the products, please read all the safety precautions carefully to ensure proper product use. The safety precautions described below are to help you use the product safely and correctly, and to prevent injury or damage to you, other people, and assets. Always adhere to the following safety regulations: ISO4414 (Pneumatic fluid power - Recommendations for the application of equipment to transmission and control systems) and JIS B 8370 (Pneumatic system regulations).

The directions are ranked according to degree of potential danger or damage: "DANGER", "WARNING!", "CAUTION!", and "ATTENTION!".

 DANGER	Indicates situations that can be clearly predicted as dangerous. Death or serious injury may result if the situation is not avoided. It could also result in damage or destruction of assets.
 WARNING	Indicates situations that, while not immediately dangerous, could become dangerous. Death or serious injury may result if the situation is not avoided. It could also result in damage or destruction of assets.
 CAUTION	Indicates situations that, while not immediately dangerous, could become dangerous. Failure to avoid the situation creates the risk of minor or semi-serious injury. It could also result in damage or destruction of assets.
 ATTENTION	While there is little chance of injury, this content refers to points that should be observed for appropriate use of the product.

- **This product was designed and manufactured for use in general industrial machinery.**
- When selecting and handling equipment, the system designer or another person with sufficient knowledge and experience should always read the safety precautions, catalog, instruction manual and other literature before commencing operation. Improper handling is dangerous.
- After reading the Instruction Manual, catalog, and other documentation, always store them in a location that allows easy availability for reference to users of this product.
- Whenever transferring or lending the product to another person, always attach the instruction manual, catalog, and other information to the product where they are easily visible in order to ensure that the new user can use the product safely and properly.
- The danger, warning and caution items listed under these safety precautions do not cover all possible contingencies. Read the catalog and instruction manual carefully, and always keep safety first.

 **DANGER**

- Do not use the product for the purposes listed below:
 1. Medical equipment related to maintenance or management of human lives or bodies
 2. Machines or equipment designed for the purpose of moving or transporting people
 3. Critical safety components in mechanical devices
 This product has not been planned or designed for purposes that require high levels of safety. Using the product in any of the ways described above creates the risk of loss of human life.
- Do not use the product in locations with or near dangerous substances such as flammable or ignitable substances. This product is not explosion-proof. Doing so creates the risk of ignition and fire.
- When mounting the product, always make sure it is secure and sufficiently supported. Falling, dropping, or abnormal operation of the product creates the risk of personal injury.
- Persons using a pacemaker or other similar medical devices should maintain a distance of at least one meter [3.28 ft] away from the product. There is a possibility that the pacemaker will malfunction due to the magnetic field, etc.
- Never attempt inappropriate disassembly or assembly of the product relating to basic construction, or to its performance or functions. Doing so creates the risk of injury, electric shock, fire, etc.
- Do not splash water on the product. Spraying water on the product, washing the product, or using the product under water creates the risk of malfunction, leading to injury, electric shock, fire, etc.
- Always turn off power before inspecting or cleaning the product, or performing maintenance. Failure to do so creates the risk of electric shock.
- Never attempt to modify the product in any way. Doing so creates the risk of abnormal operation, leading to injury, electric shocks, fire, etc.

 **WARNING**

- Do not use the product in excess of its specification range. Doing so creates the risk of product breakdown, loss of function, or damage. It could also drastically reduce operating life.
- Be sure to fully implement shielding measures whenever using the product in the locations described below. Failure to do so creates the risk of abnormal operation, damage to machinery, or personal injury.
 1. Locations where large electric currents and strong magnetic fields are generated
 2. Locations that may be subject to radiation from radioactive emissions
- Use safety circuits or design a system that prevents damage to machinery and personal injury when the machine is shut down due to an emergency stop or electrical power failure.

- Do not share a conduit with or wire parallel to power lines or high voltage lines. Noise from these lines may cause the equipment to operate erratically.
- Before supplying electricity to the device and before starting operation, always conduct a safety check of the area of machine operation. Unintentional supply of air or electricity creates the risk of electric shock or injury due to contact with moving parts.
- Do not touch the discharge needle, terminals, or switches, while power is turned on. Doing so creates the risk of electric shock and abnormal operation.
- Do not allow the product to be thrown into fire. Doing so creates the risk of the product exploding and the release of toxic gases.
- Do not sit on the product, place your foot on it, or place other objects on it. Doing so creates the risk of injury due to tripping or the product tipping over or falling, resulting in product damage and abnormal, erratic, or runaway operation.
- Before conducting any kind of product inspection, maintenance, or replacement, be sure to completely cut off the power supply.
- Before performing any kind of wiring work, be sure to turn off power. Failure to do so creates the risk of electric shock.
- Do not allow the power cord, lead wires, and other cords to become damaged. Allowing a cord to become damaged, bent excessively, pulled, rolled up, placed under heavy objects, or squeezed between two objects creates the risk of current leaks or defective continuity that can lead to fire, electric shock, or abnormal operation.
- Do not connect or disconnect connectors while power is turned on. Also, never apply unnecessary force to connectors. Doing so creates the risk of personal injury, device damage, and electric shock due to abnormal machine operation.
- Always refer to the instruction manual and other documentation for information about proper product wiring and piping. Improper wiring and piping creates the risk of damage and abnormal operation.
- After completing wiring work, check to make sure that all connections are correct before turning on power.
- Correctly apply the rated voltage to the product. Applying the wrong voltage will make it impossible to obtain the rated function, and creates the risk of damage to and burnout of the product.
- Do not place the AC adapter cable, or the power or signal wires of the products on moving parts because there is a risk they may be severed.
- Should you ever notice smoke, strange odors, or noise being emitted, stop using the equipment. Continued use creates the risk of fire and electric shock.

 **CAUTION**

- Do not use the product in locations subject to direct sunlight (ultraviolet rays), dust, salt, iron particles, or humidity, or in ambient atmospheres that include organic solvents, phosphate ester type hydraulic oil, sulfur dioxide gas, chlorine gas, acids, etc. Doing so could lead to loss of function, sudden degradation of performance, and reduced service life.

Instructions and precautions for handling the ionizer

- This product uses sensitive electronic components. When handling the product take care to avoid dropping it, allowing it to come into contact with other objects, or otherwise subjecting it to excessive impact. Even if the product appears undamaged, damage to internal components can cause abnormal operation.
- When installing the product, be sure to allow adequate work space around it. Failure to do so will make it more difficult to conduct daily inspections or maintenance, which could eventually lead to system shutdown or damage to the product.
- Always be sure to post an "operation in progress" sign during installation, adjustment, or other operations, to avoid unintended electric power supply. Unintended power supply can cause electric shock and sudden operation, creating the risk of personal injury.



ATTENTION

- Whenever considering use of this product in situations or environments not specifically noted in the catalog or in manuals, or in applications where safety is an important requirement such as in aircraft facilities, combustion equipment, leisure equipment, safety equipment, and other places where human life or assets may be greatly affected, take adequate safety precautions such as allowing plenty of margin for ratings and performance, or fail-safe measures. Be sure to contact Koganei before use in such applications.
- Always check the instruction manual and other reference materials for product wiring and piping.
- When handling the product, wear protective gloves, safety glasses, safety shoes, and other protective clothing.
- When the product can no longer be used or is no longer necessary, dispose of it appropriately as industrial waste.
- Equipment may exhibit degraded performance and function over its operating life. Always conduct daily inspections of the equipment, and confirm that all requisite system functions are satisfied, to prevent accidents from happening.



Other

- When using this product in a system, use only genuine Koganei parts or equivalent (recommended) parts. When conducting maintenance and repairs, always use genuine Koganei parts or equivalent parts (recommended parts). Always observe the prescribed methods and procedures.

Koganei bears no responsibility if these safety precautions are not fully observed.

Ionizer safety precautions



DANGER

- High voltage is applied to the discharge needle, creating the risk of electric shock. Never touch the discharge needle while power is turned on.



WARNING

- The tip of the discharge needle is a sharp point. Care is required when handling the needle. Improper handling of the discharge needle creates the risk of personal injury.
- Before conducting any kind maintenance, inspection, repair, connecting, disconnecting, or replacing pipes, or similar operations on a product that uses pressurized air, always be sure first to completely cut off the air supply and confirm that residual pressure inside the product or in piping connected to the product is zero. In particular, be aware that residual air will still be in the air compressor or air storage tank.
- Ionizers use air as their medium. Do not use any other type of medium.
- Except for fan unit type (-F□) ionizers, always supply air first before applying power. Applying power while air is not being supplied creates the risk of adversely affecting machinery and the environment.
- Check to make sure that the discharge needle unit is locked before applying air.



CAUTION

- An ionizer emits ozone into the atmosphere. Do not use it in an enclosed space, in particular. Be sure to ventilate the area if you are using multiple units.
- Do not try to check for ozone odor by bringing your face close to the ion air flow outlet. Doing so may injure your nose and throat.
- Never try to use an ionizer for any other purpose beside static charge removal.

- Before performing piping work, thoroughly flush the inside of the pipes with compressed air. Metal chips, sealant tape, and rust generated while performing piping work create the risk of clogging and malfunction.
- For the medium, use clean air that does not include any oil or water.
- This product cannot be used if the medium or ambient atmosphere includes any of the substances below. Organic solvents, phosphate type hydraulic oil, sulfur dioxide gas, chlorine gas, or acids.
- Static charge removal may not be possible by ion blowing if there is a charged object in the vicinity of or touching another object. Pay attention to the environment surrounding the static charge removal target when setting up the ionizer.
- Static charge removal performance is reduced if the ionizer is not fully grounded.
- The life of the discharge needle depends on operating environment conditions. Periodic maintenance is required because performance is reduced under bad operating environment conditions (high humidity, etc.) or if the discharge needle is not cleaned.
- Note that inrush current occurs when power is turned on. When power on/off is controlled by PLC or other means, control using H.V. OFF.

Instructions and precautions for handling the ionizer



General precautions

1. Do not apply extreme force to the exterior of the product.
2. Do not disassemble or modify the product.
3. Do not expose the product to ultraviolet rays, wind, or rain.

Mounting

1. Install the product on a flat surface. Twisting or bending during mounting creates the risk of abnormal operation.
2. Do not exceed a tightening torque of 0.5 N·m [4.4 in-lbf] when mounting a bracket on the product.
3. Avoid water, oil, dirt, high temperatures, and high humidity when installing the machine. Avoid locations that are subject to condensation, in particular.
4. Do not insert screws deeper than 5 mm [0.197 in] into the main unit during installation. Doing so may damage it.
5. Assure there is enough space during installation so that the suction ports are not blocked.
6. If you are using multiple ionizers in ion polarity control mode, they must be at least 500 mm [19.7 in] apart.

Wiring

1. When using a power supply with a commercially available switching regulator, be sure to connect a frame ground (F.G.).
2. When using devices that generate noise (switching regulator, inverter motor, etc.) in the vicinity of the installation, be sure to connect a frame ground (F.G.) to the devices.
3. After completing wiring work, check to make sure that all connections are correct.

Precautions During Use

1. Always turn off power before doing inspection, cleaning, or maintenance work.
2. Should any malfunction occur, be sure to contact Koganei for adjustment and repair.
3. Periodic maintenance is important to maintain performance. Do periodic maintenance according to the instructions in the product's instruction manual.
4. Periodically check equipment (rubber parts) that are used near the ionizer for deterioration caused by ozone.
5. Do not use the product in a moving section of a machine where there is vibration or shock.
6. Do not place the AC adapter cable, or the power or signal wires of the products on moving parts because there is a risk they may be severed.
7. Never use a needle or any other sharp pointed object to perform key operations.
8. Parameters that are set are written to the EEPROM and retained there. Note that the EEPROM has a limited service life. The guaranteed number of rewrites is 100,000.



General precautions

Wiring



1. When using a power supply with a commercially available switching regulator, be sure to connect a frame ground (F.G.).
2. When using devices that generate noise (switching regulator, inverter motor, etc.) in the vicinity of the potential sensor, be sure to connect a frame ground (F.G.) to the devices.
3. After completing wiring work, check to make sure that all connections are correct.

Precautions During Use

1. Check fluctuations in the power source to confirm they do not exceed the ratings before turning on the power.
2. Never use a needle or any other sharp pointed object to perform key operations.
3. Use the screws (M3×0.5, 14 mm [0.551 in] long) provided with the potential sensor or use M3×0.5 screws. Use a tightening torque of 0.3 N·m [2.7 in·lbf]. Be careful, if you over tighten the screws it may damage the potential sensor.
4. Be sure to connect an ground. Potential is measured based on the earth potential, if an earth is not connected, measurement of potential will not be accurate.
5. The potential sensor's body is connected to earth. Use sufficient insulation if the installation is in a location in which voltage is applied.
6. Do not touch the measurement unit. Also, do not expose it to high-pressure blown air. Doing so may damage the detector unit.
7. Do not allow dust to collect in the environment around the measurement unit.
8. If consistent potential sensing is required, we recommend waiting at least 10 minutes after connecting the power before doing any operations.
9. This sensor measures the strength of an electric field and calculates a voltage value. Note that anything that disturbs an electric field (relays, solenoids, metal objects, etc.) in the vicinity of the sensor or between the object being measured and the sensor can affect measured values.
10. If the measurement unit needs to be cleaned, point it downward and clean it by using blown air at a pressure of 0.1 MPa [15 psi] or less from a distance of 100 mm [3.94 in] or more.

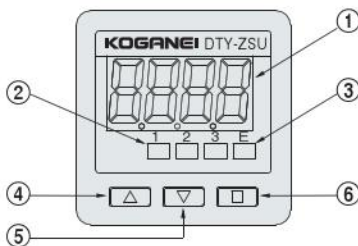
Nomenclature and functions of the monitor



No.	Name	Description
①	Display	Shows charge potential, settings, and errors
②	Sensor indicators	Shows which sensor's voltage is being displayed
③	Error indicator	Lights when an error has occurred
④	Up button ()	Used for settings and to change the sensor indicators
⑤	Down button ()	Used for settings and to change the sensor indicators
⑥	Mode button ()	Used to do various settings

1. Check wiring before supplying power, incorrect wiring of the monitor cables or power & switch output cables will damage both the monitor and the potential sensors.
2. Parameters that are set are written to the EEPROM and retained there.
Note that the EEPROM has a limited service life. The guaranteed number of rewrites is 100,000.

How to connect monitor transmission cables

The cable and mini-clamp connector (male) are not connected when the cables for the monitor are delivered, use the following procedure to connect them.

1. Check to make sure that the connector cover (lead wire holder) is raised above the body of the connector. Note that a connector whose cover is even with the body of the connector cannot be used.

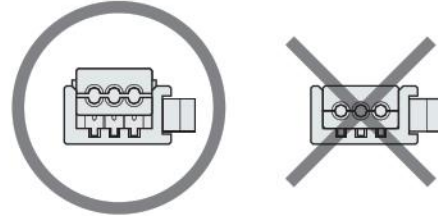

2. Insert the lead wires into the connector cover holes in accordance with the information in the table below. Check to make sure the lead wires are fully inserted as far as they will go by viewing the semi-transparent top cover of the connector (wire goes in about 9 mm [0.35 in].)
Note that supplying power while connections are incorrect will damage the controller and control device you are using.

Number on connector	Wire color	Name of signal (DTY-ZSU-D)
1	Black	TXD
2	Brown	RXD
3	Blue	0V

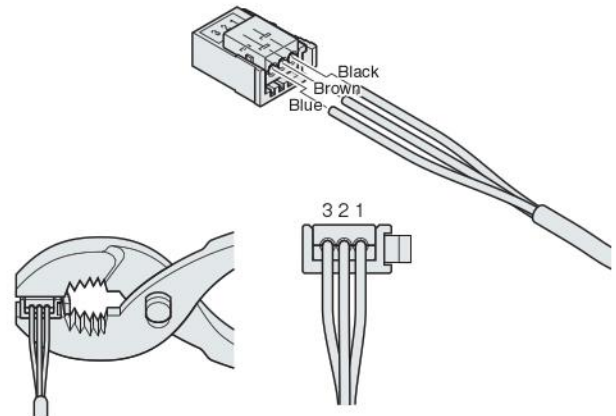

3. Taking care that lead wires do not come out of the connector, use pliers or some other type of hand tool to squeeze the cover and body of the connector until the cover is pressed into the body.
Do not apply force in excess of 980.7 N [220.5 lbf].
Connection is complete when the cover is even with the connector body.
4. Double check to make sure that wiring is correct.

Connecting and disconnecting cables for transmission and for power & switch output

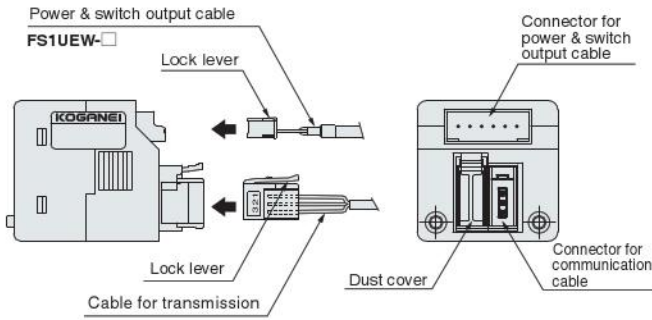

To attach the power & switch output cable and transmission cable, position the lock lever as shown in the illustration, and then insert until they lock into place with the monitor side connector.

For disconnection, press down fully on the lock lever as you hold the connector and pull to disconnect. At this time, take care not to apply undue force to the lead wires.

Attaching the front protective cover and parts for panel mount

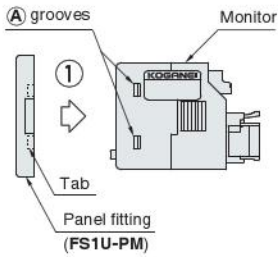

① Attach the panel fitting to the front of the monitor. At this time, the tabs on the inside of the panel fitting should go into the (A) grooves on the monitor.

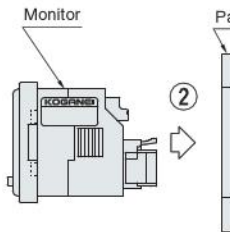

② Insert the monitor into the hole in the panel from the front.

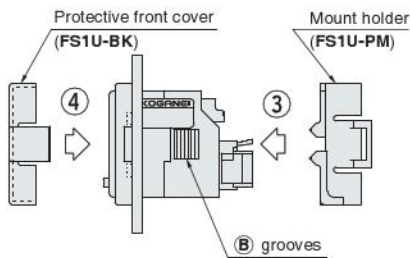

③ From step ②, insert the mount holder so it hooks on the (B) grooves of the monitor.

④ Attach the protective front cover.

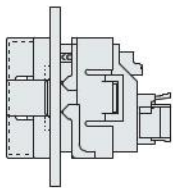

*To disassemble it, use a screwdriver to remove the mount holder and do it in the opposite order of assembling it.

Attaching the protective front cover and bracket

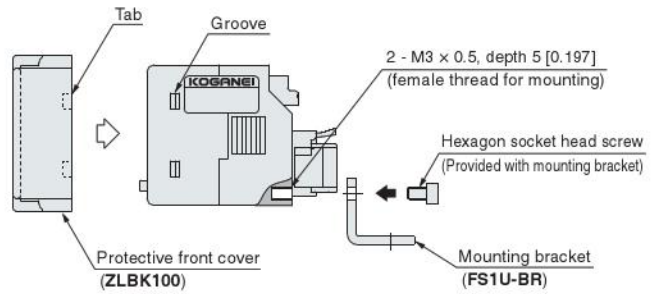

Install the mounting bracket on the back of the monitor using the hexagon socket head screws (M3×0.5, 5 mm [0.197 in] long) to mount it.

Use a tightening torque of 0.5 N·m [4.4 in·lbf]. Attach the protective front cover so the tabs inside the cover enter the grooves on the inside. To remove the cover, hold the covers by the protrusions and remove them.

Specifications

External potential sensor type

Item	Model	DTY-BX01 main unit External potential sensor type			
		DTY-BX01-200- (L)	DTY-BX01-400- (L)	DTY-BX01-200-F	DTY-BX01-400-F
Input voltage		24 VDC \pm 5%			
Consumption current	mA	110	170	240	410
Output voltage	kV	\pm 2 (during high frequency operation)			
Indicator lamp (LED)		①POWER (Power display LED: Green) ②H.V (Discharge display LED: Blue) ③CHECK (Static charge removal display and cleaning timer display LED: Yellow) ④ALARM (Alarm display LED: Red)			
Safety circuit		An error is output and the LED on the main unit lights when there is a circuit error or abnormal output.			
Input/output	Power supply signal connector (7P)	①24 VDC ②0V ③F.G. ④Check output (Open collector output; 50 mA max at 24 VDC, internal voltage drop 0.3 V max at 5 mA) ⑤Alarm output (Open collector output; 50 mA max at 24 VDC, internal voltage drop 0.3 V max at 5 mA) ⑥Signal output (Open collector output; 50 mA max at 24 VDC, internal voltage drop 0.3 V max at 5 mA) ⑦Discharge stop (H.V off) input (Discharge stop by 0 V; at short circuit, no voltage input, internal drop voltage of 0.5 V or less, input current 5 mA at 24 VDC)			
	External potential sensor connectors	2 ch			
	Communication interface	RS232C			
Integrated sensor		None			
Low particle specifications ^{Note 1}		Available		None	
Ionizer installation distance mm [in]		50 [1.97] or over			
Static charge removal mode		Ion polarity control static charge removal mode, pulse static charge removal mode, high-frequency static charge removal mode			
Ion balance	V	Within \pm 30 (150 mm [5.91 in] from center of main unit, at 0.1 MPa [15 psi] supply air pressure, during high frequency operation)		Within \pm 30 (150 mm [5.91 in] from center of main unit, during high frequency operation)	
Ozone concentration	ppm	0.04 or less (300 mm [11.81 in] from center of main unit, at 0.25 MPa [36 psi] supply air pressure)		0.04 or less (300 mm [11.81 in] from center of main unit)	
Particle generation amount ^{Note 1, Note 2}	Particles	50 or less		—	—
Medium		Air (Clean air, water vapor and oil removed)		—	—
Operating air pressure range	MPa [psi]	0.05 to 0.5 [7 to 73]			
Expanded air flow rate	ℓ /min [ft ³ /min] (ANR)	60 [2.12] (when 0.5 MPa [73 psi] is applied)	100 [3.53] (when 0.5 MPa [73 psi] is applied)	—	—
Fan air volume	m ³ /min [ft ³ /min]	—	—	0.09 [3.2] (per fan)	
Number of fans installed	Fan	—	—	4	8
Weight ^{Note 3}	g [oz]	153 [5.40]	275 [9.70]	229 [8.08]	430 [15.17]
Operating environment		0 to 40°C [32 to 104 °F] /65% or less (Non-condensation)			
Accessories		User manual, brackets (1 set), power signal cable		User manual, brackets (1 set), power signal cable, filter for fan (installed)	

Note 1: Low particle specifications have an -L in the order code.

2: Particle diameter: 0.3 μ m or greater at 1 [ft³/min]. Actual measured value, not guaranteed value.

3: Bracket not equipped.

Remark: Ion balance is measured according to Koganei measurement conditions. Contact Koganei for details.

Circuit Diagram

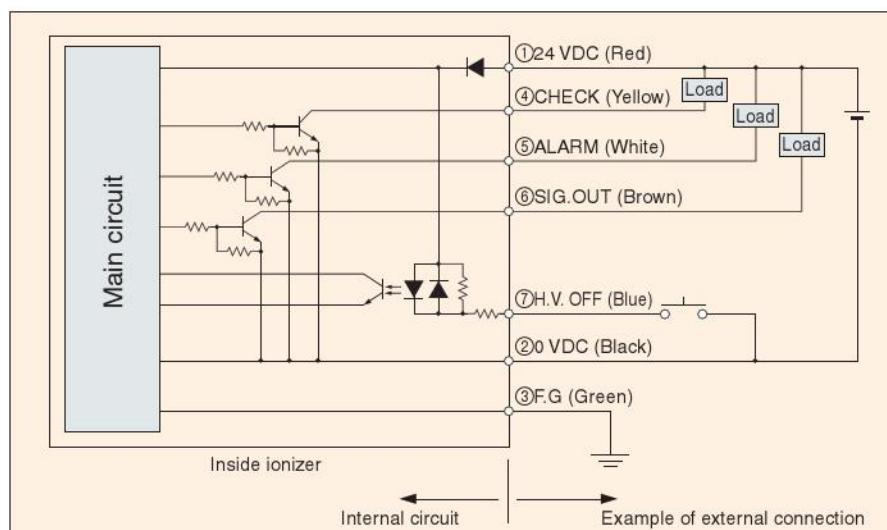

Specifications

Integrated potential sensor type

Item	Model	DTY-BX01 main unit Integrated potential sensor type			
		DTY-BX01-200- (L) B	DTY-BX01-400- (L) B	DTY-BX01-200-FB	DTY-BX01-400-FB
Input voltage		24 VDC \pm 5%			
Consumption current	mA	110	170	240	410
Output voltage	kV	\pm 2 (during high frequency operation)			
Indicator lamp (LED)		①POWER (Power display LED: Green) ②H.V (Discharge display LED: Blue) ③CHECK (Static charge removal display and cleaning timer display LED: Yellow) ④ALARM (Alarm display LED: Red)			
Safety circuit		An error is output and the LED on the main unit lights when there is a circuit error or abnormal output.			
Input/output	Power supply signal connector (7P)	①24 VDC ②0V ③F.G. ④Check output (Open collector output; 50 mA max at 24 VDC, internal voltage drop 0.3 V max at 5 mA) ⑤Alarm output (Open collector output; 50 mA max at 24 VDC, internal voltage drop 0.3 V max at 5 mA) ⑥Signal output (Open collector output; 50 mA max at 24 VDC, internal voltage drop 0.3 V max at 5 mA) ⑦Discharge stop (H.V off) input (Discharge stop by 0 V; at short circuit, no voltage input, internal drop voltage of 0.5 V or less, input current 5 mA at 24 VDC)			
	External potential sensor connectors	1 ch			
	Communication interface	RS232C			
Integrated sensor		Available			
Low particle specifications ^{Note1}		Available		None	
Ionizer installation distance ^{Note2}	mm [in]	50 to 150 [1.97 to 5.91] (Recommended working distance: 50 mm [1.97 in])			
Static charge removal mode		Ion polarity control static charge removal mode			
Ion balance	V	Within \pm 30 (at center of main unit, at 0.1 MPa [15 psi] supply air pressure, during high frequency operation)		Within \pm 30 (at center of main unit, during high frequency operation)	
Ozone concentration	ppm	0.04 or less (300 mm [11.81 in] from center of main unit, at 0.25 MPa [36 psi] supply air pressure)		0.04 or less (300 mm [11.81 in] from center of main unit)	
Particle generation amount ^{Note1, Note3}	Particles	50 or less		—	—
Medium		Air (Clean air, water vapor and oil removed)		—	—
Operating air pressure range	MPa [psi]	0.05 to 0.5 [7 to 73]			
Expanded air flow rate	ℓ /min [ft ³ /min] (ANR)	60 [2.12] (when 0.5 MPa [73 psi] is applied)	100 [3.53] (when 0.5 MPa [73 psi] is applied)	—	—
Fan air volume	m ³ /min [ft ³ /min]	—	—	0.09 [3.2] (per fan)	
Number of fans installed	Fan	—	—	4	8
Weight ^{Note4}	g [oz]	158 [5.57]	284 [10.02]	236 [8.33]	440 [15.52]
Operating environment		0 to 40°C [32 to 104 °F]/65% or less (Non-condensation)			
Accessories		User manual, brackets (1 set), power signal cable		User manual, brackets (1 set), power signal cable, filter for fan (installed)	

Note 1: Low particle specifications have an -L in the order code.

2: If the target object is small and far from the device, it may affect the sensor range and accurate ion polarity control may not be possible. If this happens, move the device closer.

3: Particle diameter: 0.3 μ m or greater at 1 [ft³/min]. Actual measured value, not guaranteed value.

4: Bracket not equipped.

Remark: Ion balance is measured according to Koganei measurement conditions. Contact Koganei for details.

Circuit Diagram

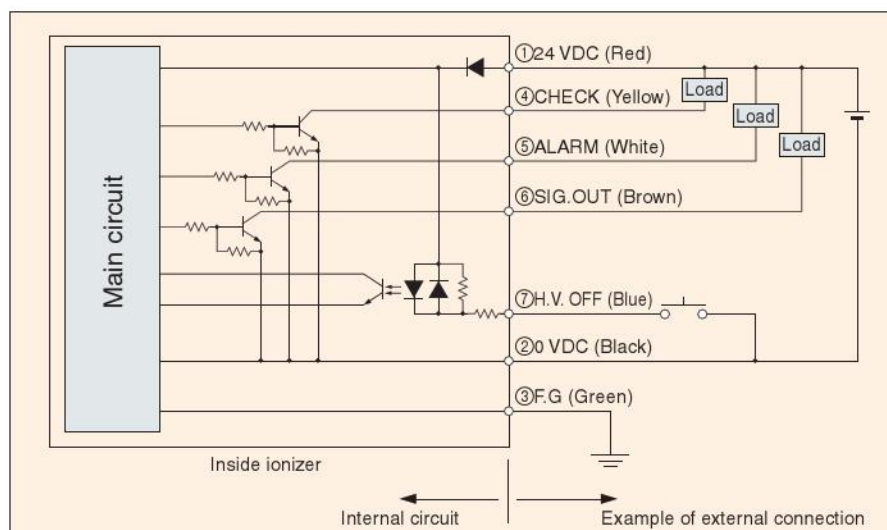

Specifications

Simple types

Item	Model	DTY-BX01 main unit	
		DTY-BX01-200-N	DTY-BX01-400-N
Input voltage		24 VDC \pm 5%	
Consumption current	mA	100	160
Output voltage	kV	\pm 2	
Indicator lamp (LED)		①POWER (Power display LED: Green) ②H.V (Discharge display LED: Blue) ③CHECK (Cleaning timer display LED: Yellow) ④ALARM (Alarm display LED: Red)	
Safety circuit		An error is output and the LED on the main unit lights when there is a circuit error or abnormal output.	
Input/output	Power supply signal connector (7P)	①24 VDC ②0V ③F.G. ④Check output (Open collector output; 50 mA max at 24 VDC, internal voltage drop 0.3 V max at 5 mA) ⑤Alarm output (Open collector output; 50 mA max at 24 VDC, internal voltage drop 0.3 V max at 5 mA) ⑥N/A (Do not connect anything) ⑦Discharge stop (H.V off) input (Discharge stop by 0 V; at short circuit, no voltage input, internal drop voltage of 0.5 V or less, input current 5 mA at 24 VDC)	
	Communication interface ^{Note 1}	RS232C	
Ionizer installation distance	mm [in]	50 [1.97] or over	
Static charge removal mode		High-frequency static charge removal mode	
Ion balance	V	Within \pm 30 (150 mm [5.91 in] from center of main unit, at 0.1 MPa [15 psi] supply air pressure)	
Ozone concentration	ppm	0.04 or less (300 mm [11.81 in] from center of main unit, at 0.25 MPa [36 psi] supply air pressure)	
Medium		Air (Clean air, water vapor and oil removed)	
Operating air pressure range	MPa [psi]	0.05 to 0.5 [7 to 73]	
Expended air flow rate	ℓ /min [ft ³ /min] (ANR)	60 [2.12] (when 0.5 MPa [73 psi] is applied)	100 [3.53] (when 0.5 MPa [73 psi] is applied)
Weight ^{Note 2}	g [oz]	146 [5.15]	268 [9.45]
Operating environment		0 to 40°C [32 to 104 °F] /65% or less (Non-condensation)	
Accessories		User manual, brackets (1 set), power signal cable	

Note 1: Monitor cannot be installed.

2: Bracket not equipped.

Remark: Ion balance is measured according to Koganei measurement conditions. Contact Koganei for details.

Circuit Diagram

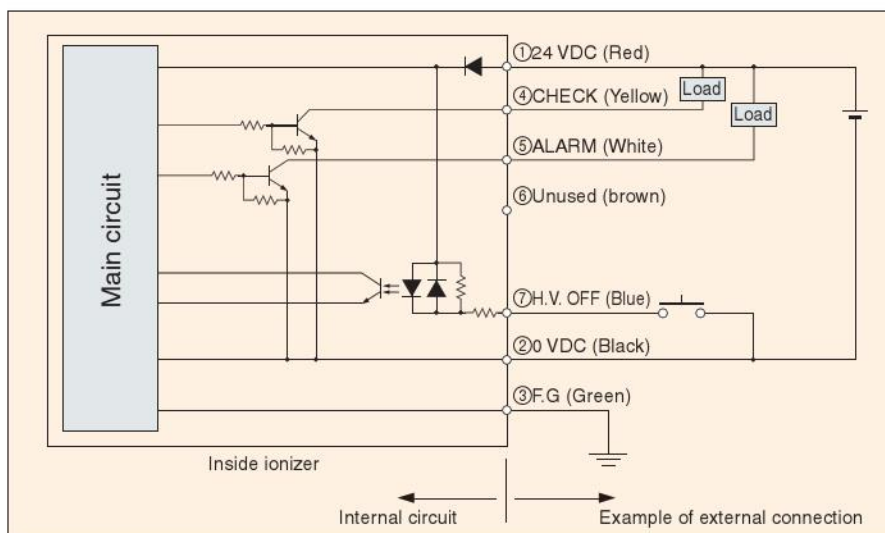

Specifications

Potential sensor

Item	Model	DTY-ZS□L-BX ^{Note}
Power		24 VDC (supplied from ionizer)
Consumption current	mA	35
Indicator lamp (LED)		Power display LED (green): Lights when power is turned on Measurement range display LED (blue): Lights when measurement voltage range is H (± 20 kV) Alarm display LED (red): Lights when range is exceeded or main unit malfunctions
Input/output		Connect to ionizer with special cable
Measurement distance	mm [in]	50 to 150 [1.97 to 5.91]
Measurement range	mm [in]	$\phi 50$ to $\phi 300$ [$\phi 1.97$ to $\phi 11.81$]
Measured voltage range	Range L	± 2 kV
	Range H	± 20 kV
Voltage resolution	Range L	2V
	Range H	20V
Accuracy		$\pm 5\%$ F.S. (measured object size $\phi 300$ mm [11.81 in], Measured distance 50 mm [1.97 in])
Data output cycle	ms	10
Temperature characteristics		0.5% F.S./ $^{\circ}$ C
Operating environment		0 to 40 $^{\circ}$ C [32 to 104 $^{\circ}$ F]/65% or less (non-condensation, non-freezing)
Storage environment	$^{\circ}$ C [$^{\circ}$ F]	-20 to 60 [-4 to 140] (non-condensation, non-freezing)
Case material		Conductive ABS resin
Outside Dimensions	mm [in]	55 (W) \times 25 (H) \times 10.5 (D) [2.165 (W) \times 0.984 (H) \times 0.413 (D)]
Mass	g [oz]	13 [0.46]
Accessories		1 cable for potential sensor, 1 bracket

★ Cannot be connected to DTY-BX01-□00-N.

Note: Option order code. It is possible to purchase when purchasing an ionizer (see the order code on page 15).

Remarks: The ambient temperature is 25 $^{\circ}$ C [77 $^{\circ}$ F] if there are no specified measurement conditions.

Monitor

Item	Model	DTY-ZSU-D-□□□
Power		24 VDC $\pm 5\%$
Consumption current	mA	50mA MAX
Indicator	Value display	7-segment LED, 4 digit display
	Display cycle	Selectable from 500 ms, 1000 ms, 3000 ms
Operating environment		-10 to 50 $^{\circ}$ C [14 to 122 $^{\circ}$ F] (non-condensation, non-freezing)
Storage environment		-20 to 80 $^{\circ}$ C [-4 to 176 $^{\circ}$ F] (non-condensation, non-freezing)
Mass	g [oz]	30 [1.06]
Accessories ^{Note}		Instruction Manual

★ Cannot be connected to DTY-BX01-□00-N.

Note: Specify cables, brackets, and other parts by order code as necessary (see the order codes on page 17).

Order codes

External potential sensor type (ion polarity control static charge removal mode, and other usages are possible)

● Ion polarity control static charge removal mode, high-frequency static charge removal mode, pulse static charge removal mode supported



DTY - BX01 - [] - [] - []



Fan unit type

Size

200 : Width 200 mm
[7.87 in]
400 : Width 400 mm
[15.75 in]

Type

Blank : Standard type
L : Low particle generation type
F : Fan unit type

External potential sensor (for external use)

Blank : No sensor
S1L : Sensor (cable 1 m [39 in]) 1 pc. included
S3L : Sensor (cable 3 m [118 in]) 1 pc. included
S1L2 : Sensor (cable 1 m [39 in]) 2 pcs. included
S3L2 : Sensor (cable 3 m [118 in]) 2 pcs. included
S1LS3L : Sensor (cable 1 m [39 in], 3 m [118 in])
1 pc. each included

- ★ Mounting brackets and power signal cable are included.
- ★ Main unit for low particle generation type comes in single layer clean packaging.

Integrated potential sensor type (Installation conditions: Distance from ionizer to target must be from 50 to 150 mm [1.97 to 5.91 in]).

● Ion polarity control static charge removal mode supported



DTY - BX01 - [] - [] - []



Fan unit type

Size

200 : Width 200 mm
[7.87 in]
400 : Width 400 mm
[15.75 in]

Type

B : Standard type (integrated sensor)
LB : Low particle generation type
(integrated sensor)
FB : Fan unit type (integrated sensor)

External potential sensor (for external use) ^{Note}

Blank : No sensor
S1L : Sensor (cable 1 m [39 in]) 1 pc. included
S3L : Sensor (cable 3 m [118 in]) 1 pc. included

Note: One potential sensor can be installed to check the static charge of the target after static charge is removed.

- ★ Mounting brackets and power signal cable are included.
- ★ Main unit for low particle generation type comes in single layer clean packaging.

Simple type (Potential sensor and monitor cannot be installed)

● High-frequency static charge removal mode supported



DTY - BX01 - [] - N



Size

200 : Width 200 mm
[7.87 in]
400 : Width 400 mm
[15.75 in]

- ★ Mounting brackets and power signal cable are included.

Order codes

Options (sold separately)

- **Discharge needle unit**
[For replacement]
DTY-ZEM-BX
DTY-ZEML-BX
(For low particle generation type)*



* Main unit comes in single layer clean packaging.

- **Filters [For replacement]**
(Units: 6-filter set)
DTY-ZFL-BX
* For fan unit type.

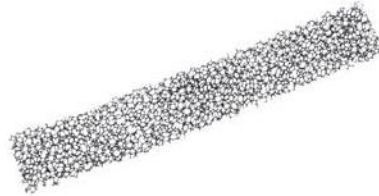

- **AC adapter**
DTY-ZPS-BX



Cable length: 1.7 m [67 in]

- **Power signal cable**
[included with main unit]
DTY-ZDSC-BX



Cable length: 1.5 m [59 in]

- **PC communication cable**
DTY-ZTC-BX (D-Sub 9-pin female)



Cable length: 3 m [118 in]

Note : Input/output function cannot be used when using the AC adapter. (24 VDC supply)

- **Mounting bracket**
[included with main unit]
DTY-ZBRS-BX
* Cannot be used with fan unit type.



- **Mounting bracket**
[included with main unit]
DTY-ZBRF-BX
* For fan unit type only.



- **Mounting bracket (with angle adjuster)**
DTY-ZBRA-BX
* For all types.



- **External potential sensor**
[Included with potential sensor cable]
DTY-ZS1L-BX
(Potential sensor cable, length is 1 m [39 in] , with bracket)
DTY-ZS3L-BX
(Potential sensor cable, length is 3 m [118 in] , with bracket)



- **External potential sensor cable**
DTY-ZSC1-BX (cable length is 1 m [39 in])
DTY-ZSC3-BX (cable length is 3 m [118 in])



Order codes

Monitor (display device)

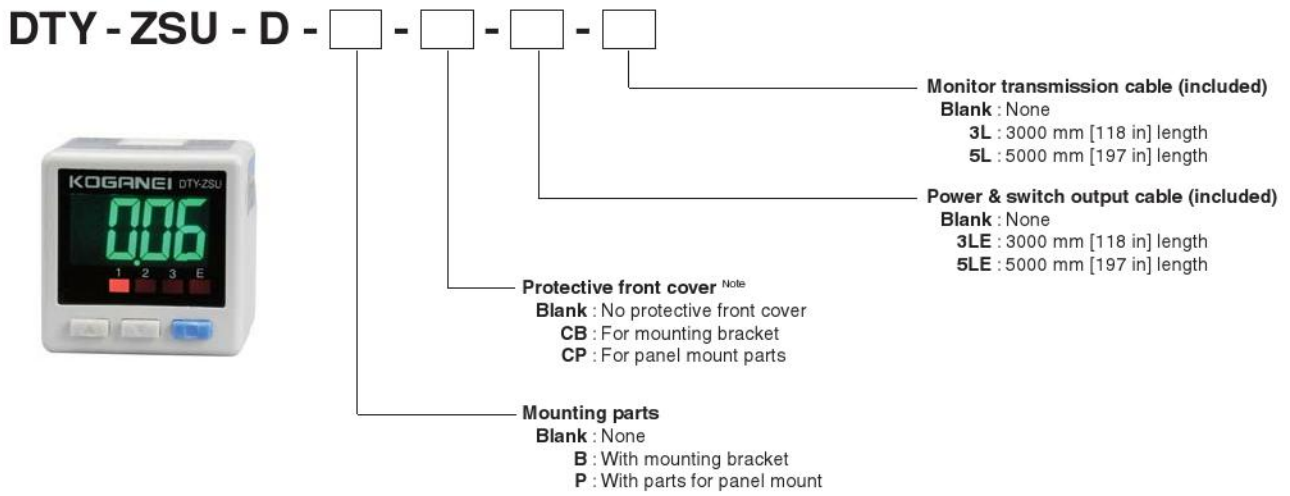

Note : **-B** (with mounting bracket) and **-CP** cannot be combined.
-P (with parts for panel mount) and **-CB** cannot be combined.

Options for monitor (sold separately)

● Power & switch output cable

FS1UEW-

Cable length
3L : 3000mm [118 in]
5L : 5000mm [197 in]



● Monitor transmission cable

DTY-ZMC -BX

Cable length
3L : 3000mm [118 in]
5L : 5000mm [197 in]



● Mounting bracket

FS1U-BR



● Front protective cover for mounting bracket

ZLBK100



● Parts for panel mount

FS1U-PM



● Front protective cover for panel mount parts

FS1U-BK



● Mini clamp wire mount plug (for monitor transmission cable)

FS1U-3M



Dimensions of external potential sensor type mm [in]

Basic type/low particle generation type

DTY-BX01-200-□, DTY-BX01-200-L-□

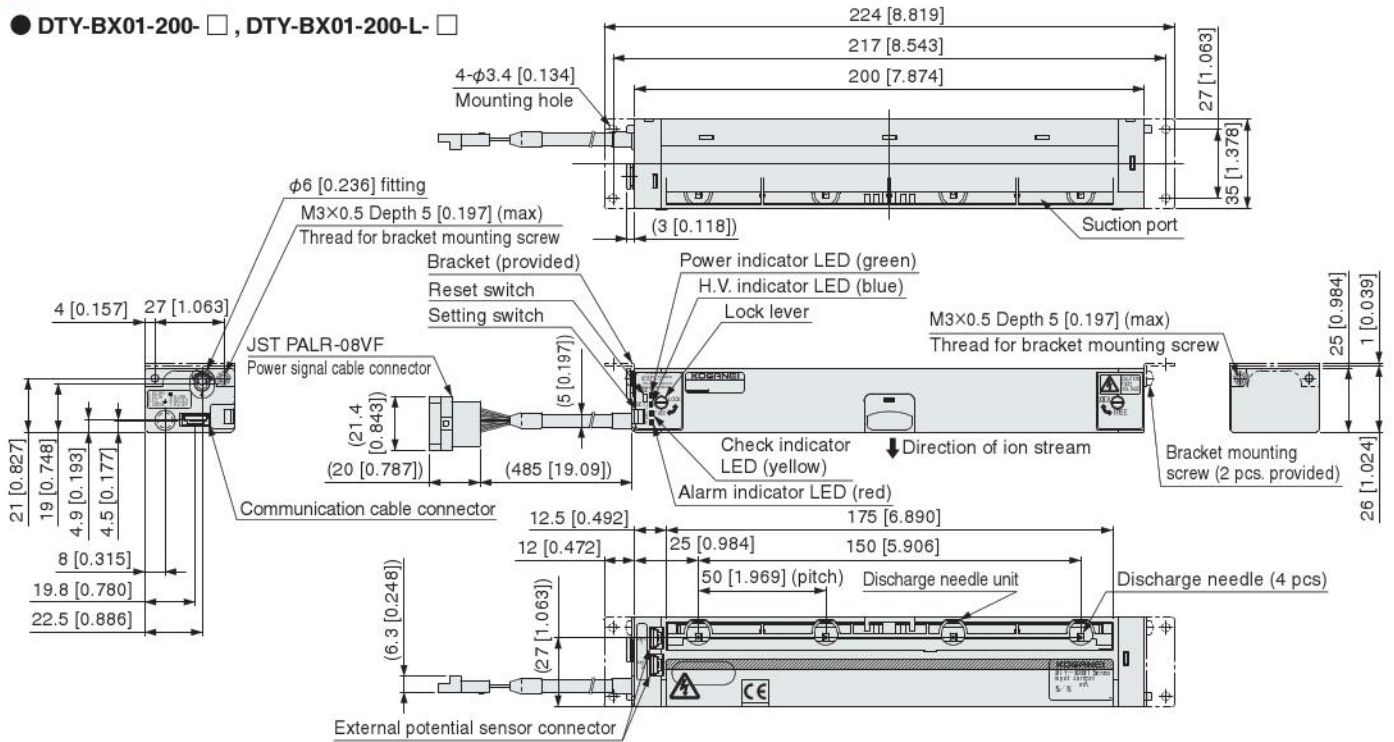

DTY-BX01-400-□, DTY-BX01-400-L-□

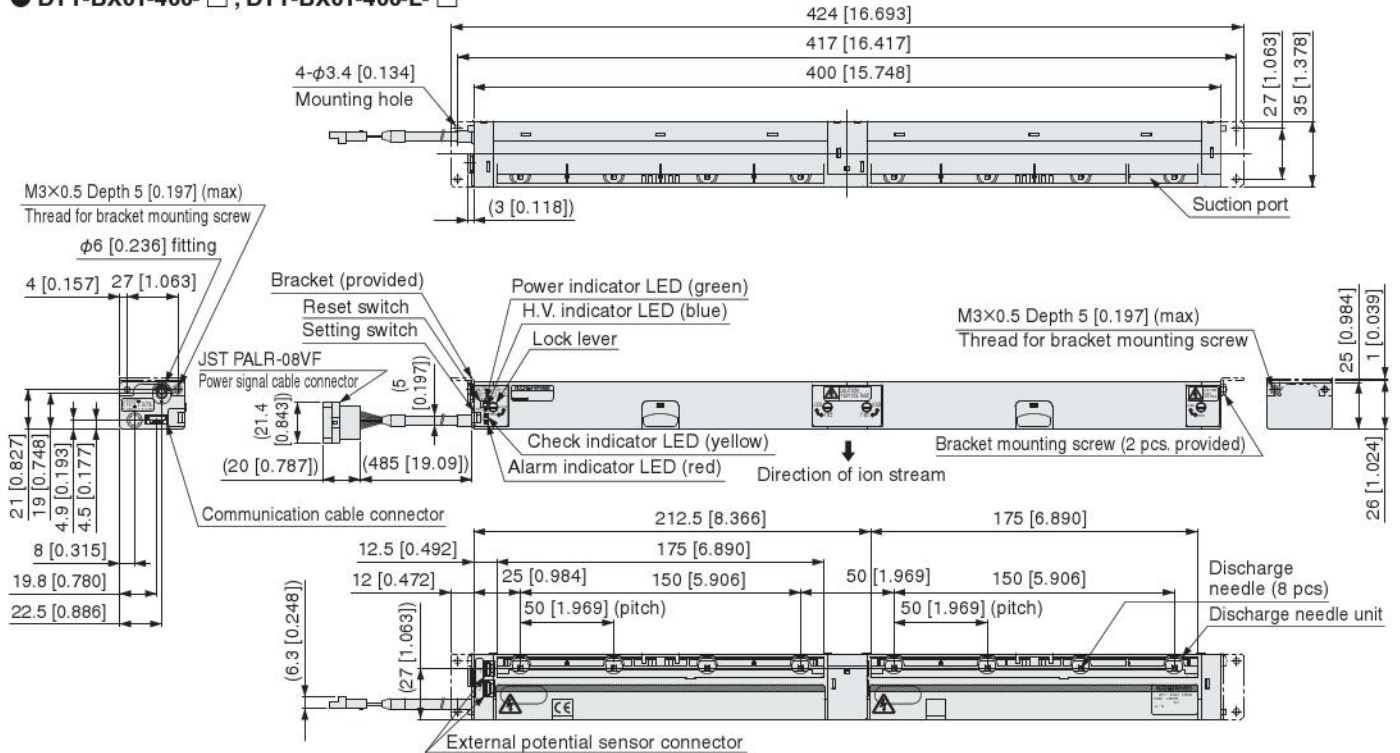

Power signal cable (provided)

DTY-ZDSC-BX

Pin position and color of lead wire

Pin no.	Lead wire color	Signal
1	Red	DC 24V
2	Black	DC 0V
3	Green	F.G.
4	Yellow	CHECK
5	White	ALARM
6	Brown	SIG.OUT
7	Blue	H.V.OFF

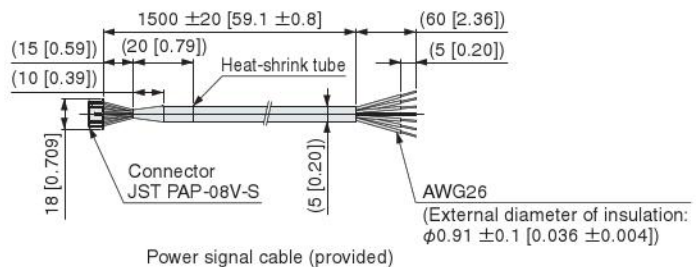

Dimensions of external potential sensor type mm [in]

Fan unit type

● DTY-BX01-200-F- □

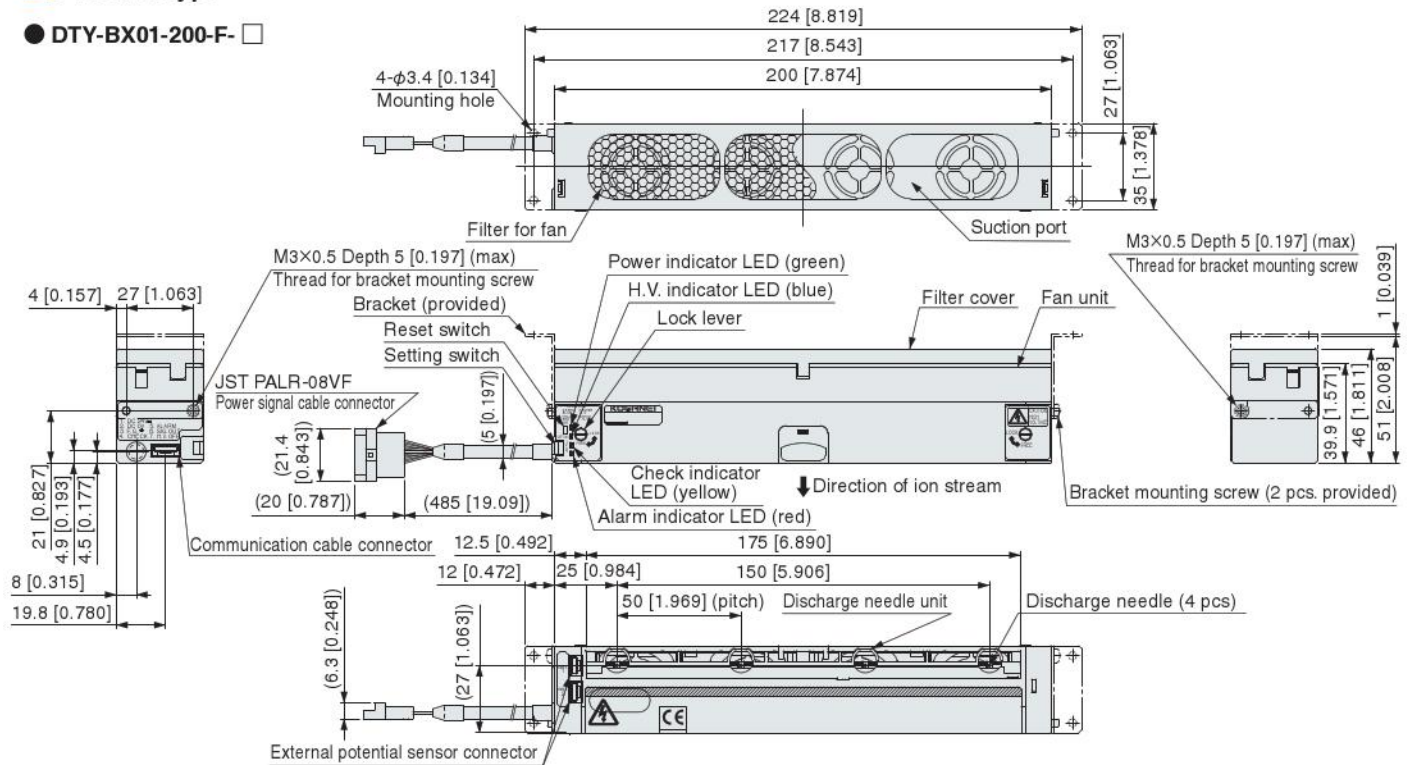

● DTY-BX01-400-F- □

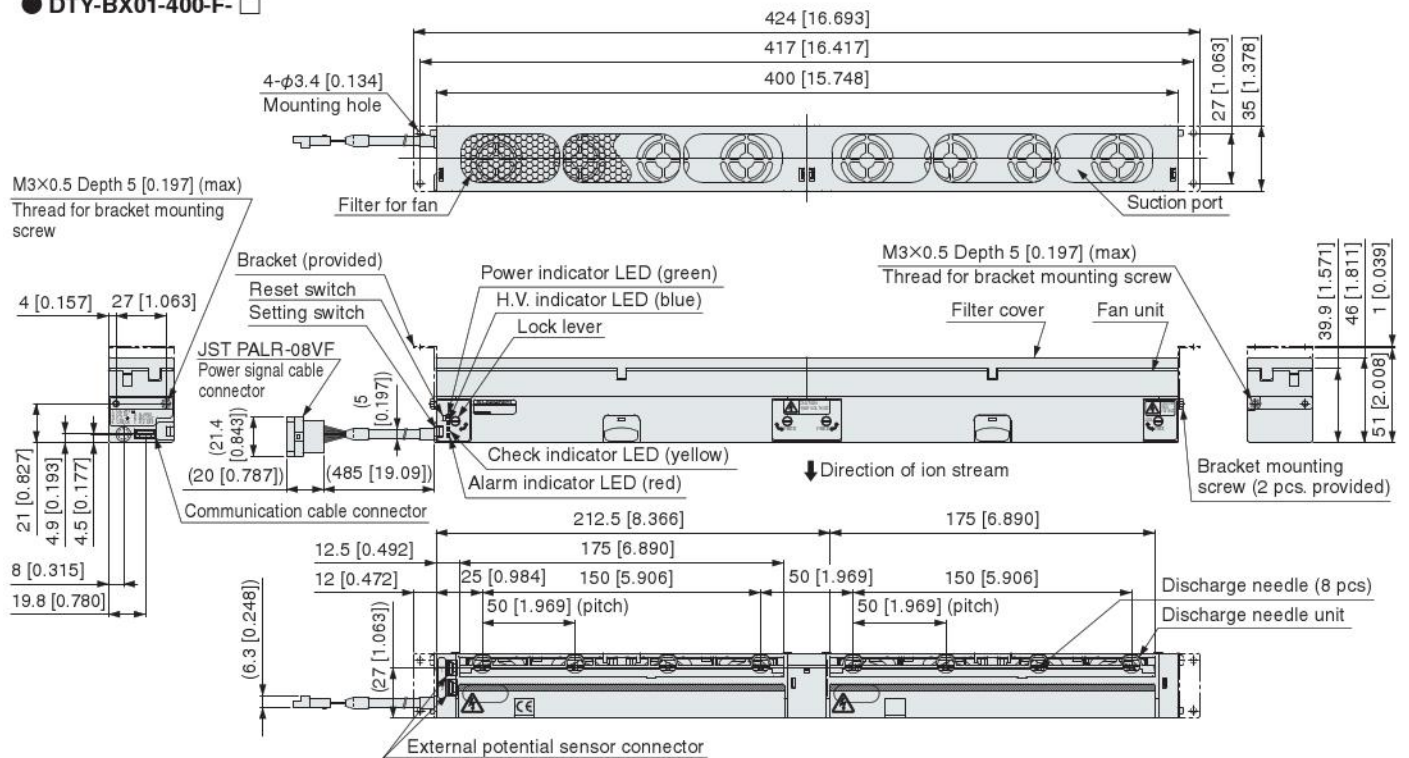

Power signal cable (provided)

● DTY-ZDSC-BX

Pin position and color of lead wire

Pin no.	Lead wire color	Signal
1	Red	DC 24V
2	Black	DC 0V
3	Green	F.G.
4	Yellow	CHECK
5	White	ALARM
6	Brown	SIG.OUT
7	Blue	H.V.OFF

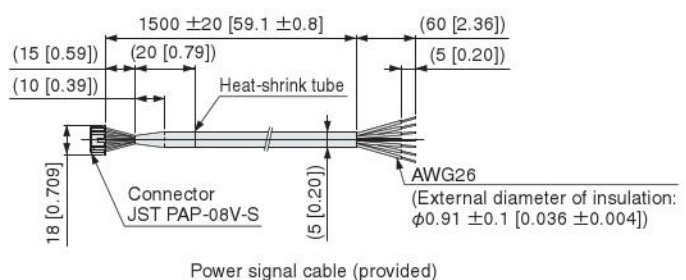

Dimensions of integrated potential sensor type mm [in]

Basic type/low particle generation type

DTY-BX01-200-B □, DTY-BX01-200-LB- □

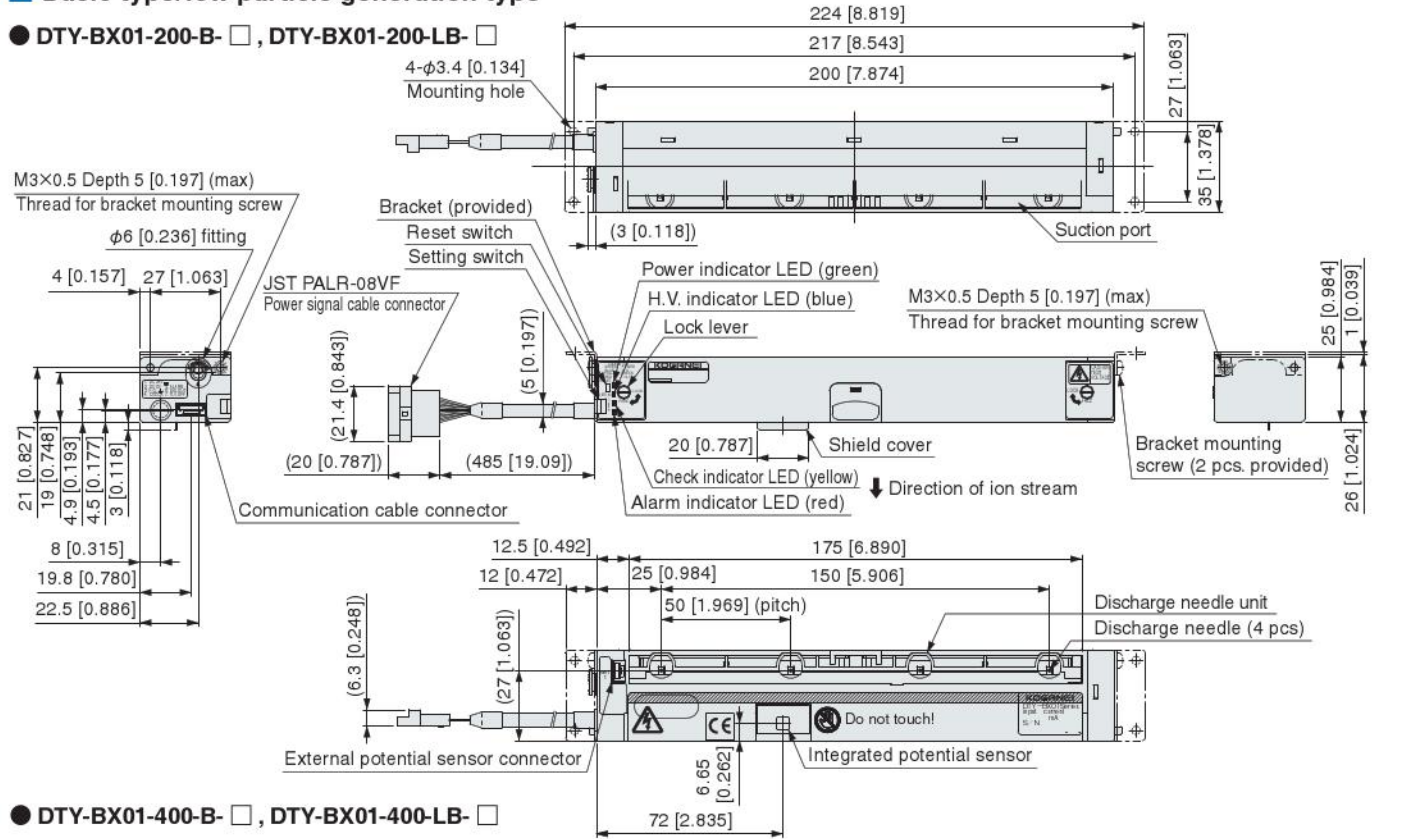

DTY-BX01-400-B □, DTY-BX01-400-LB- □

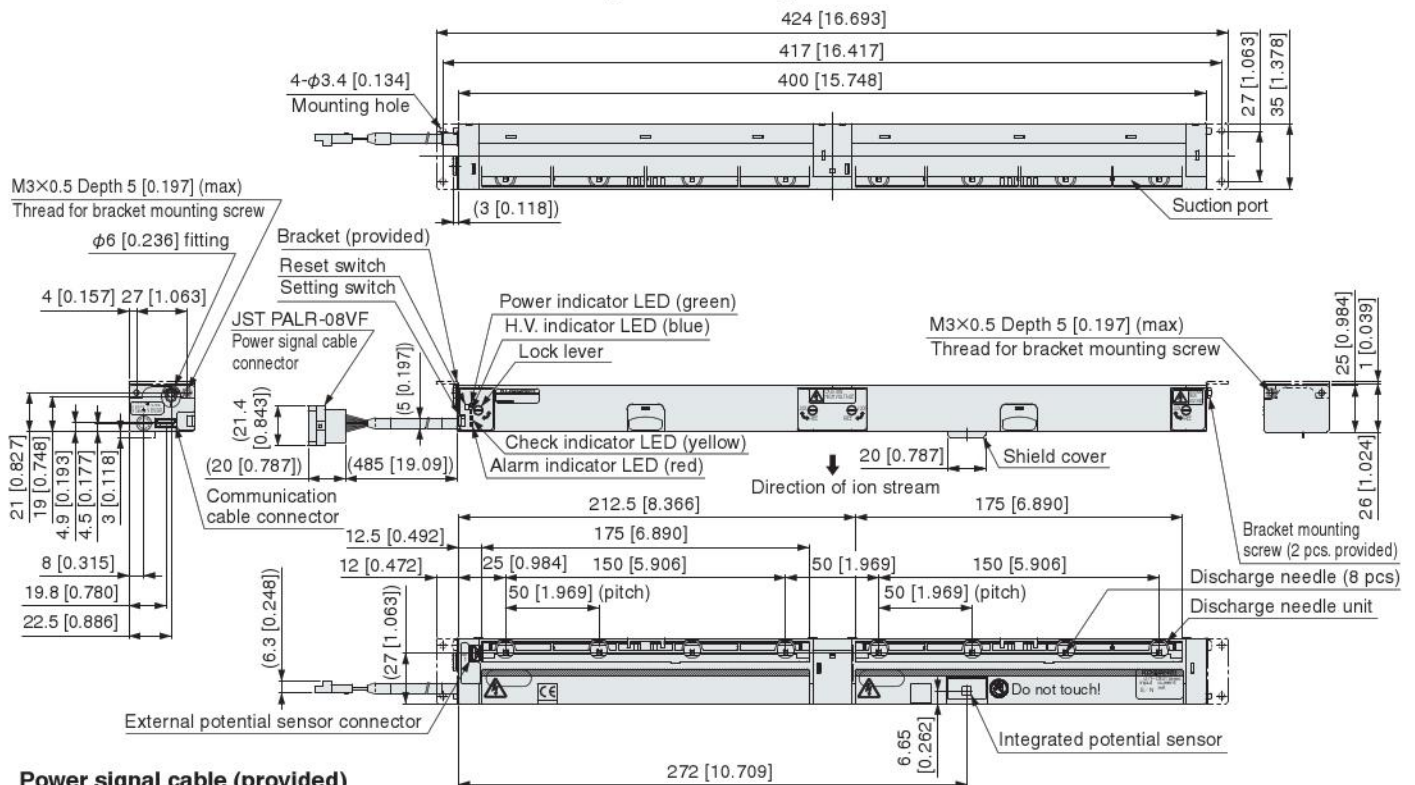

Power signal cable (provided)

DTY-ZDSC-BX

Pin position and color of lead wire

Pin no.	Lead wire color	Signal
1	Red	DC 24V
2	Black	DC 0V
3	Green	F.G.
4	Yellow	CHECK
5	White	ALARM
6	Brown	SIG. OUT
7	Blue	H.V. OFF

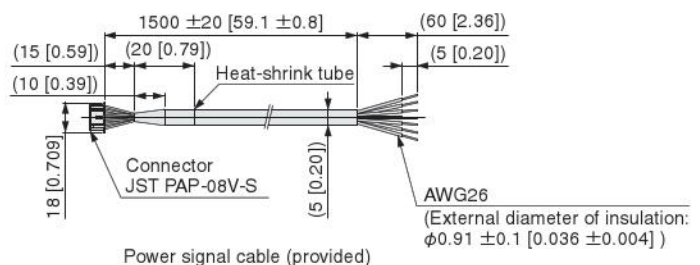

Power signal cable (provided)

Dimensions of integrated potential sensor type mm [in]

Fan unit type

● DTY-BX01-200-FB-□

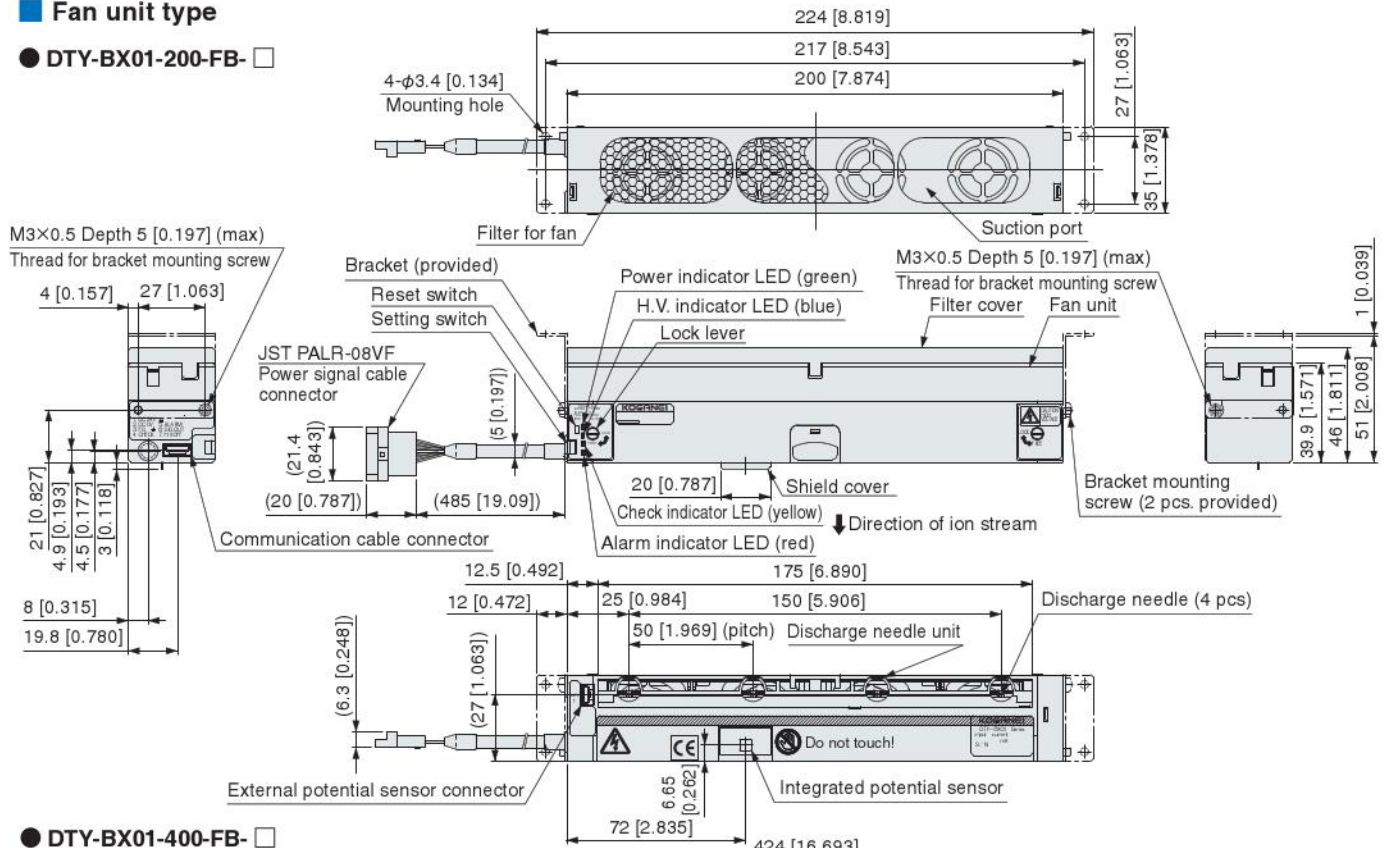

● DTY-BX01-400-FB-□

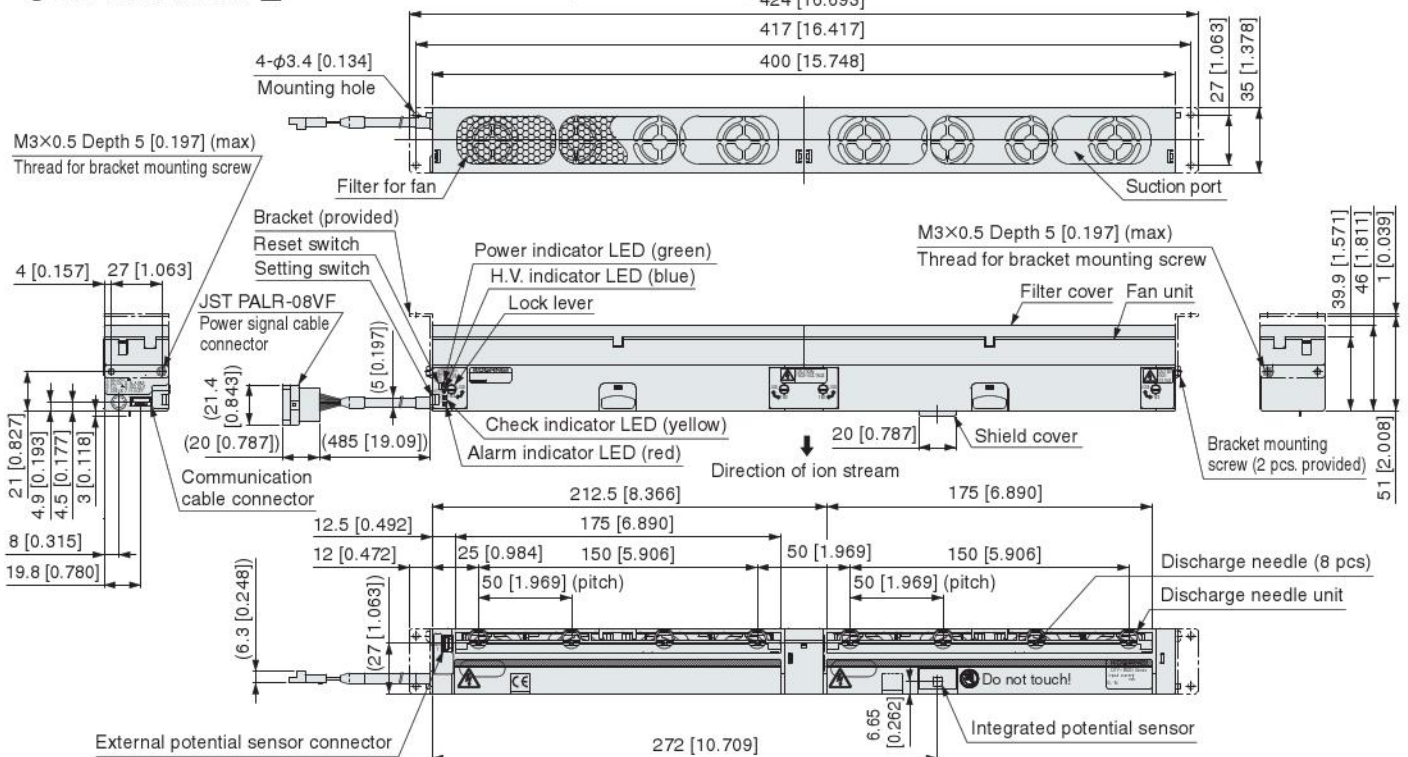

Power signal cable (provided)

● DTY-ZDSC-BX

Pin position and color of lead wire		
Pin no.	Lead wire color	Signal
1	Red	DC 24V
2	Black	DC 0V
3	Green	F.G.
4	Yellow	CHECK
5	White	ALARM
6	Brown	SIG.OUT
7	Blue	H.V.OFF

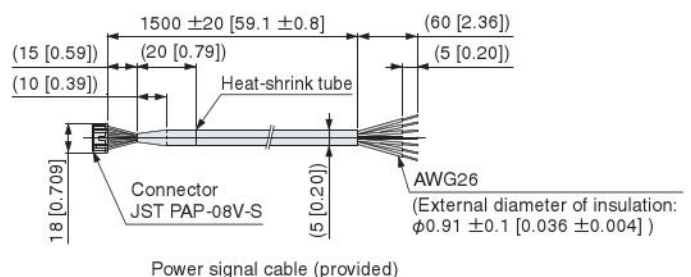

Dimensions of simple types mm [in]

● DTY-BX01-200-N

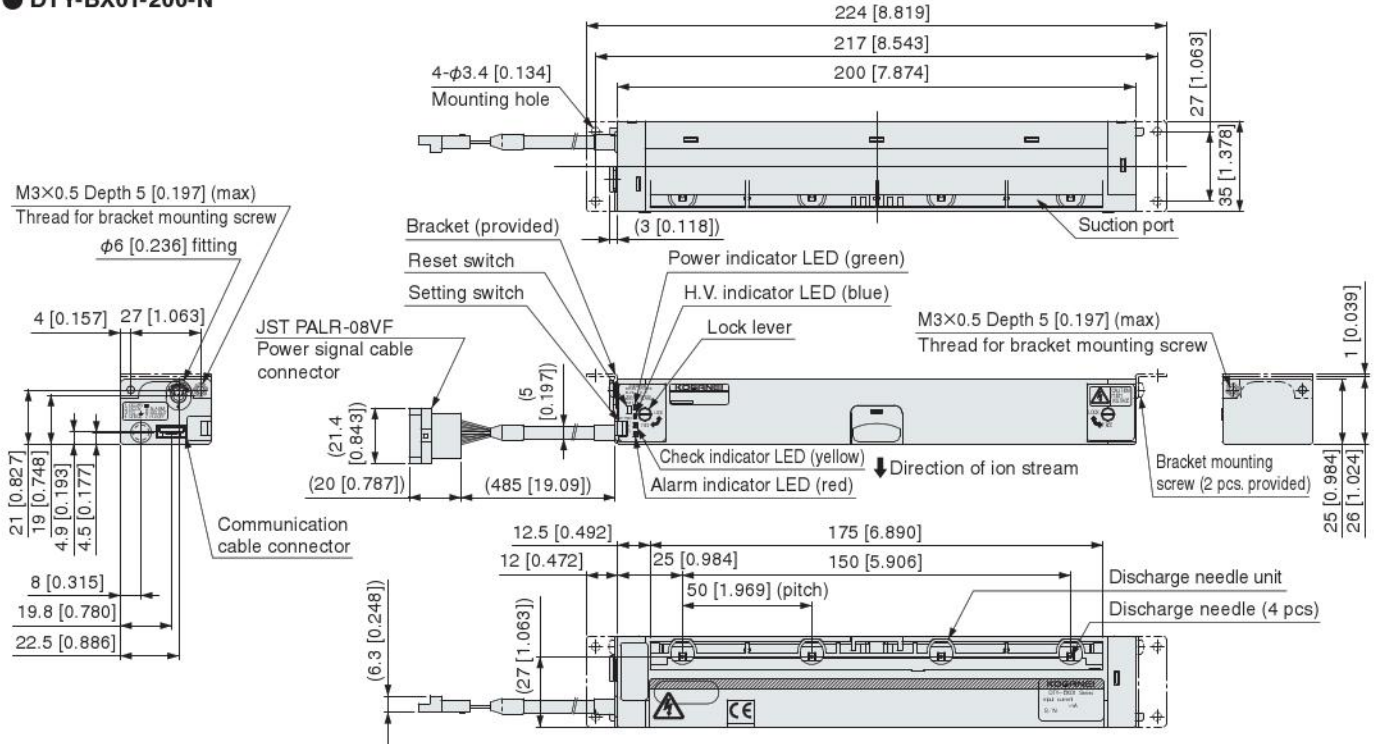

● DTY-BX01-400-N

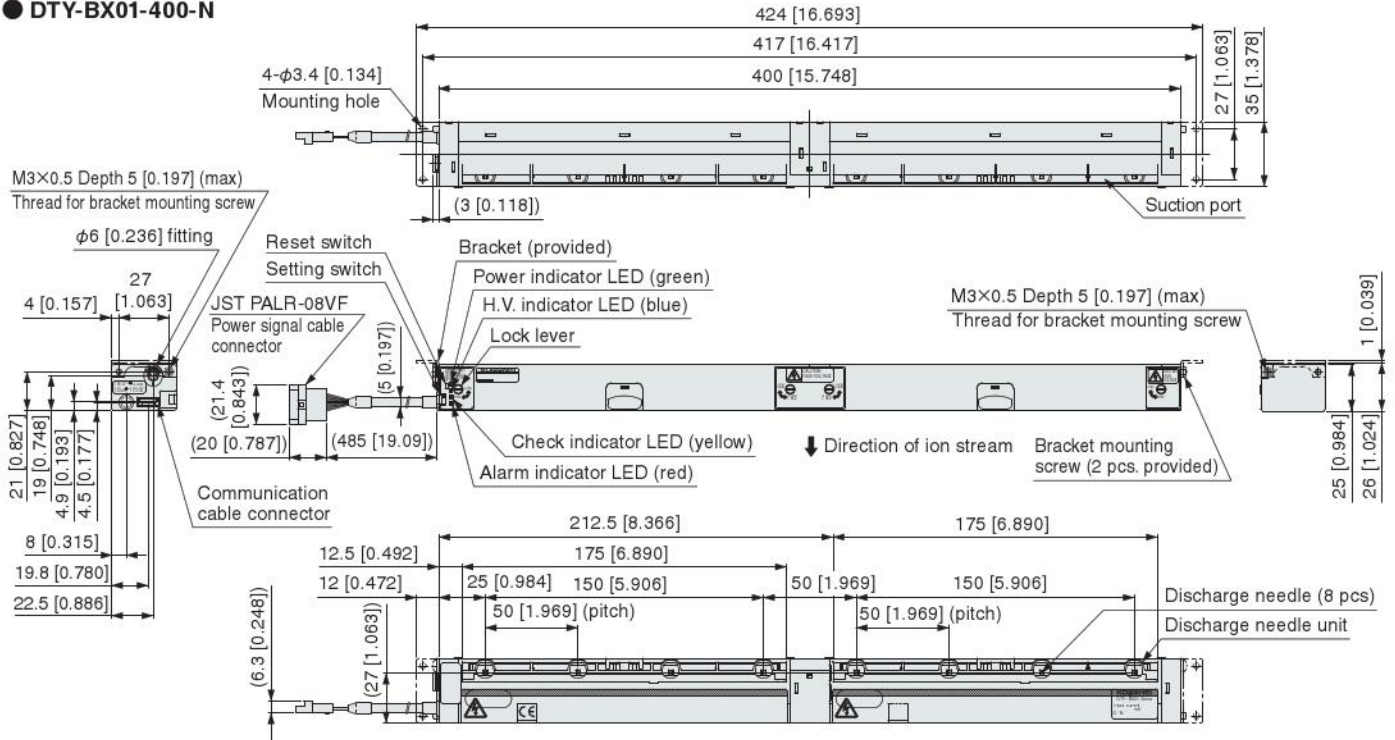

Power signal cable (provided)

● DTY-ZDSC-BX

Pin position and color of lead wire

Pin no.	Lead wire color	Signal
1	Red	DC 24V
2	Black	DC 0V
3	Green	F.G.
4	Yellow	CHECK
5	White	ALARM
6	Brown	N/A
7	Blue	H.V.OFF

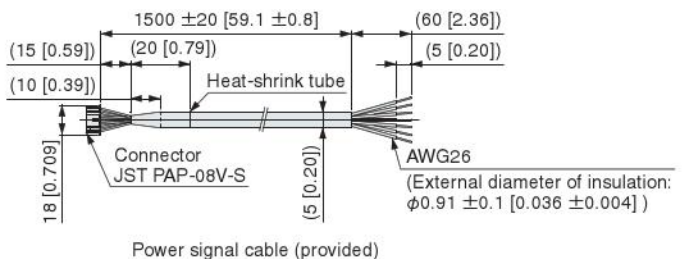

Dimensions mm [in]

External potential sensor

DTY-ZS1L-BX, DTY-ZS3L-BX

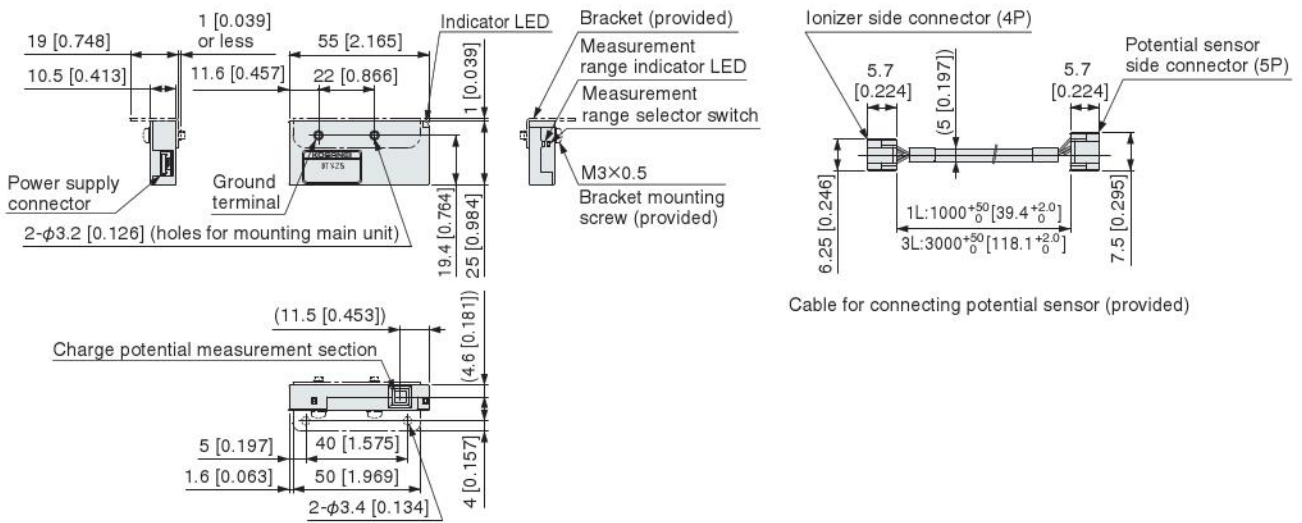

Mounting bracket (with angle adjuster)

DTY-ZBRA-BX

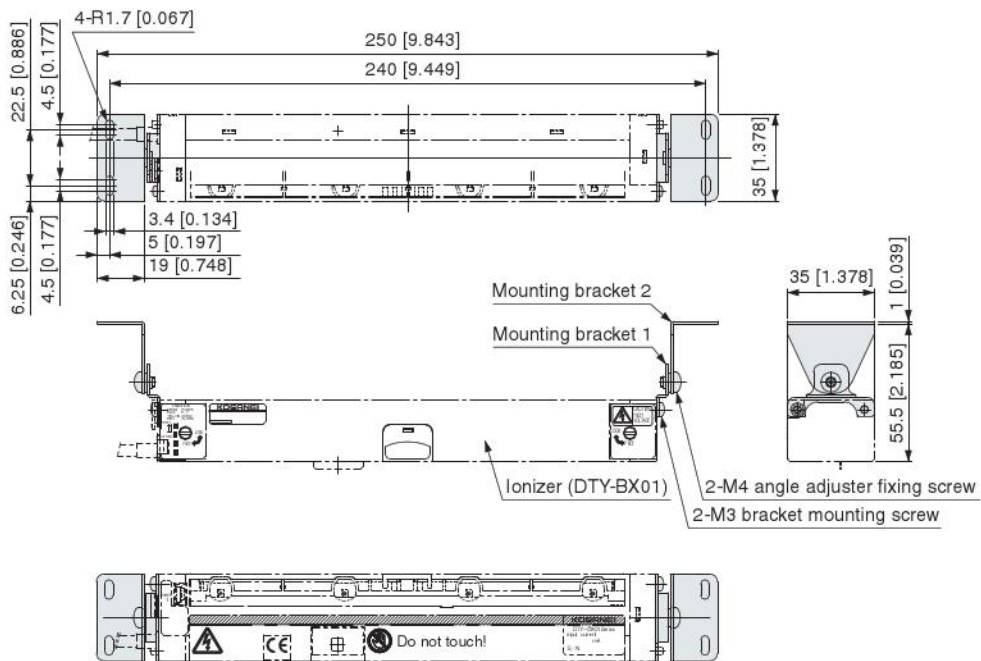

When mounted on DTY-BX01-200-□

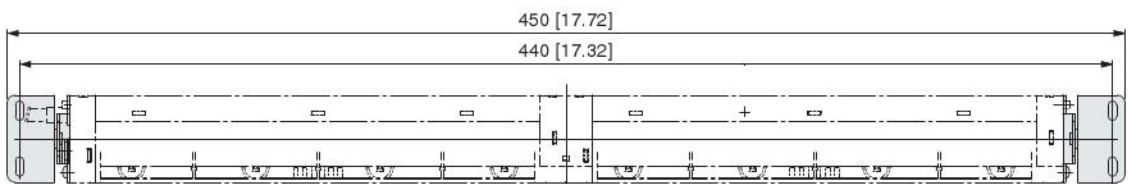

When mounted on DTY-BX01-400-□

Dimensions mm [in]

Mounting bracket Range of possible installations

● **DTY-ZBRA-BX**

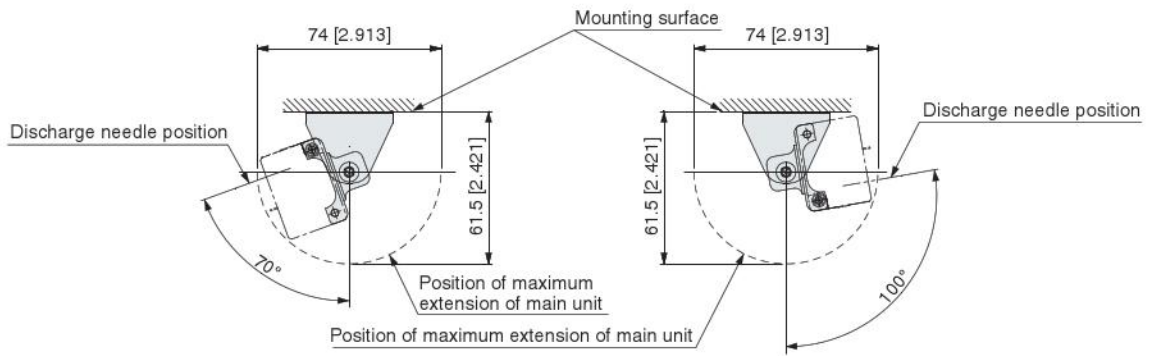

Range of possible installations when mounting DTY-BX01-□-□

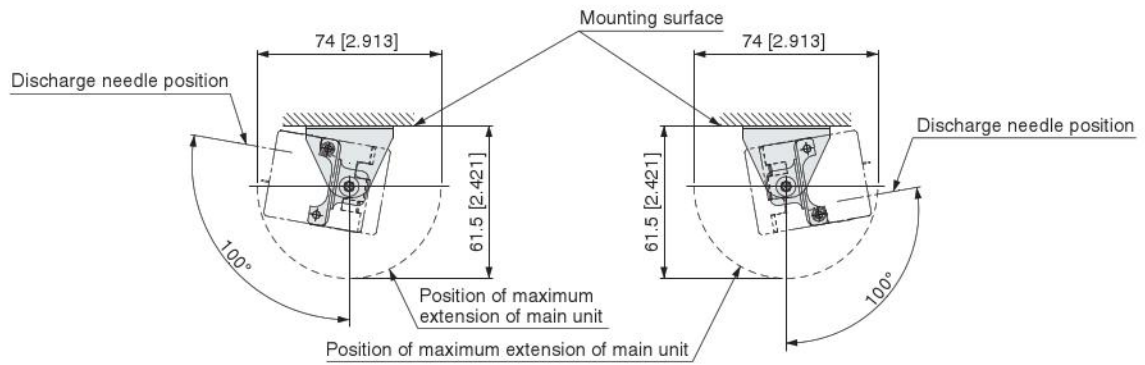

Range of possible installations when mounting DTY-BX01-□-□-□

Dimensions mm [in]

Monitor

● DTY-ZSU-D- □

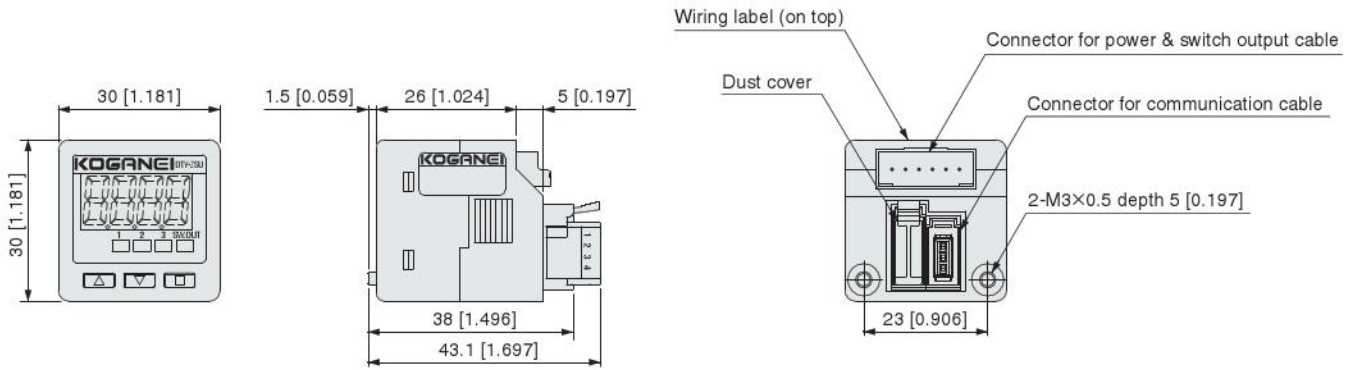

● FS1UEW- □ Power & switch output cable

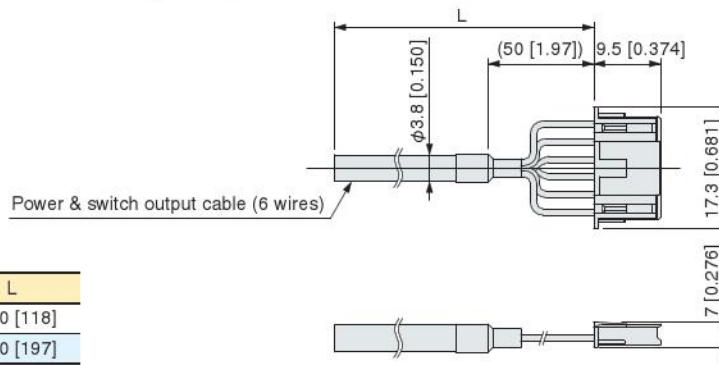

No.	Item	Color
1	24V	Red
2	0V	Black
3	N.A.	White
4	N.A.	Green
5	N.A.	Yellow
6	N.A.	Brown

Model	L
FS1UEW-3L	3000 [118]
FS1UEW-5L	5000 [197]

Monitor transmission cable

● DTY-ZMC □ -BX

Ionizer side connector (6P)

Connector terminal positions [Ionizer side]

NO.	Item	Color
1	RXD	Black
2	TXD	Brown
3	GND	Blue
4	NC	—
5	F.G.	Green
6	NC	—

Model	L
DTY-ZMC3L	3000 [118]
DTY-ZMC5L	5000 [197]

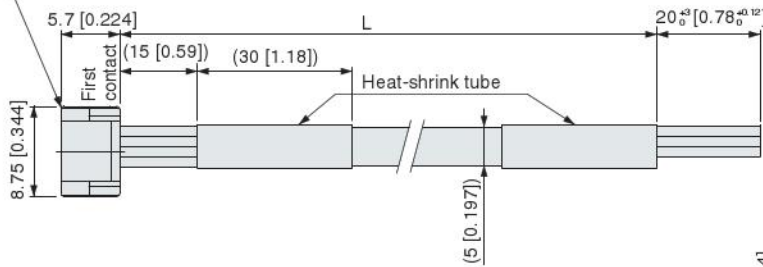

Item	Color
TXD	Black
RXD	Brown
GND	Blue

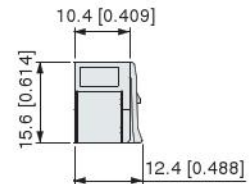

Mini clamp wire mount plug (provided)

● FS1U-BR Mounting bracket

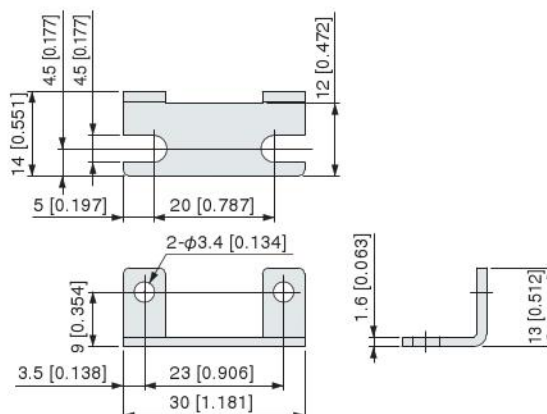

Hexagon socket head screw
M3x0.5 Length 5 [0.197] 2 pcs. provided

● FS1U-PM Parts for panel mount

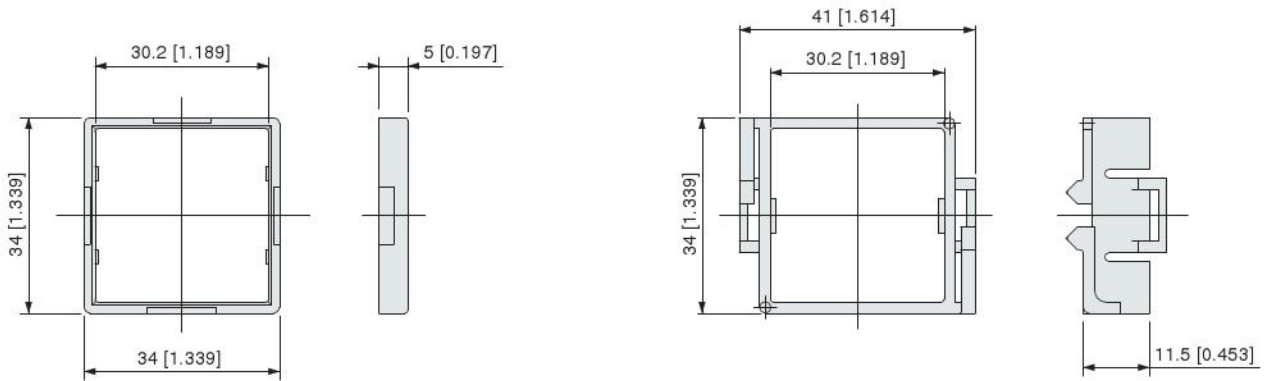

● ZLBK100 Front protective cover for mounting bracket

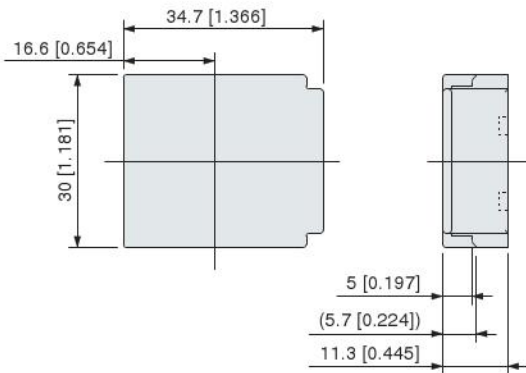

● FS1U-BK Front protective cover for parts for panel mount

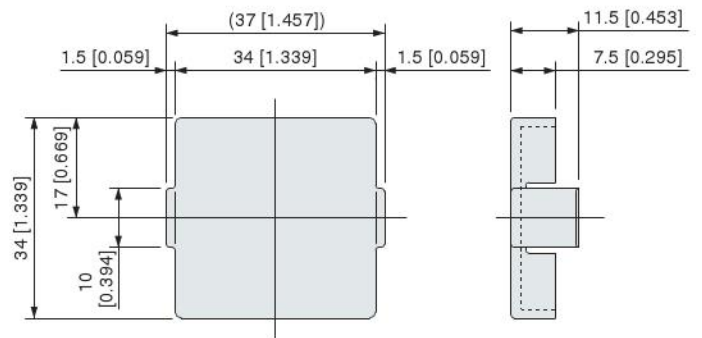

● Dimensions of mounting holes for sensor controller (panel mount)

When installing 1 unit

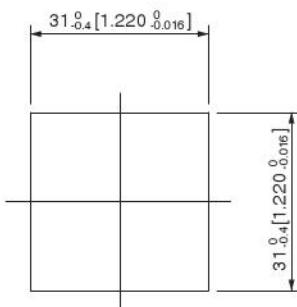

When installing n units

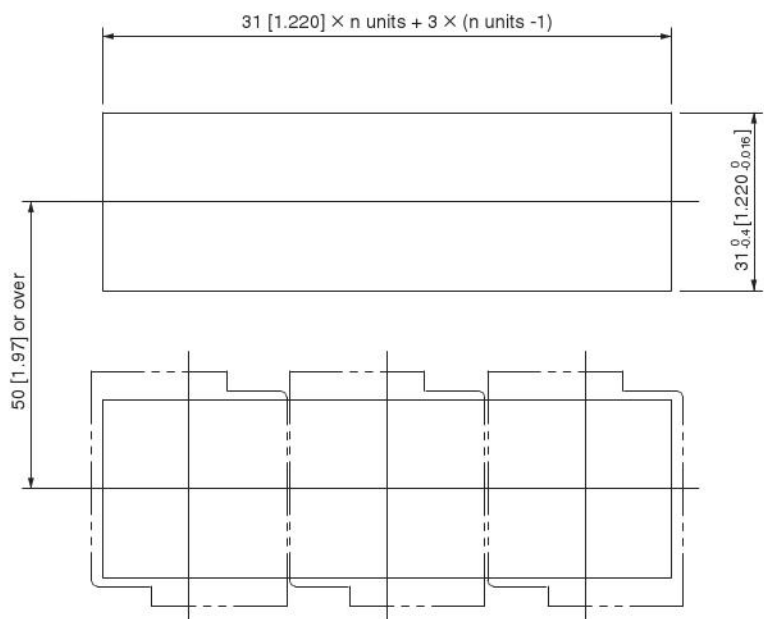

Note: Use panels that are from 1 to 6 mm [0.039 to 0.236 in] thick.

Static Charge Removal Characteristic Graph

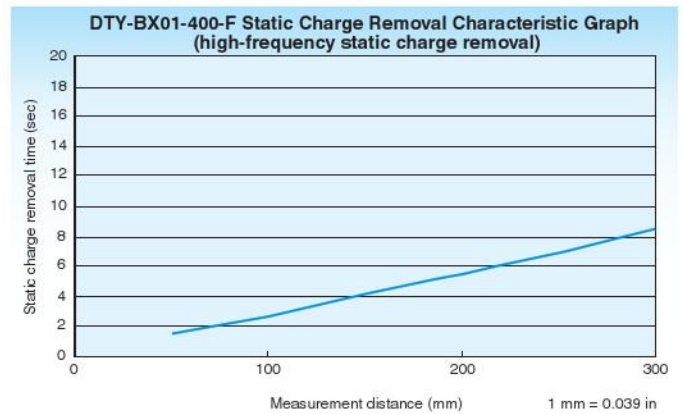
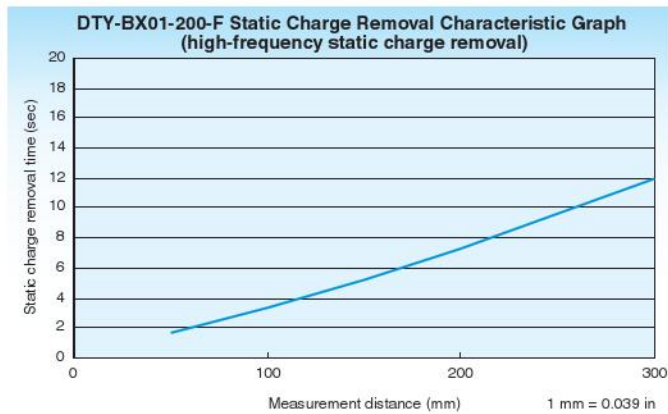
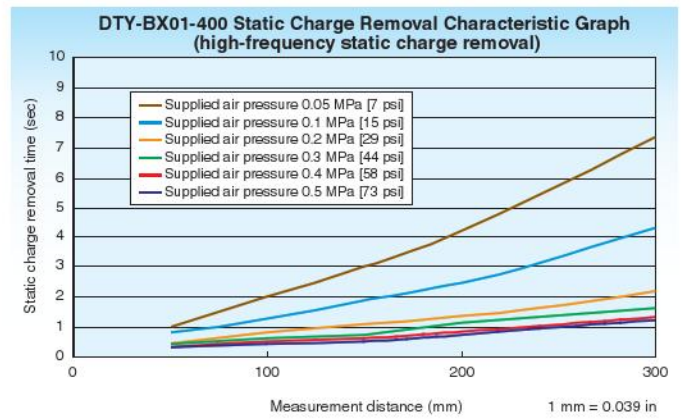
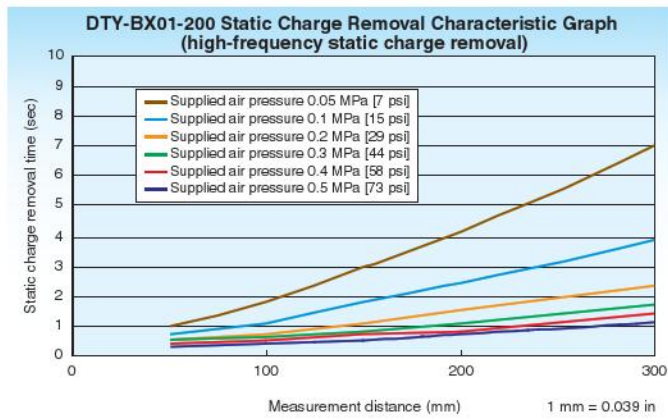
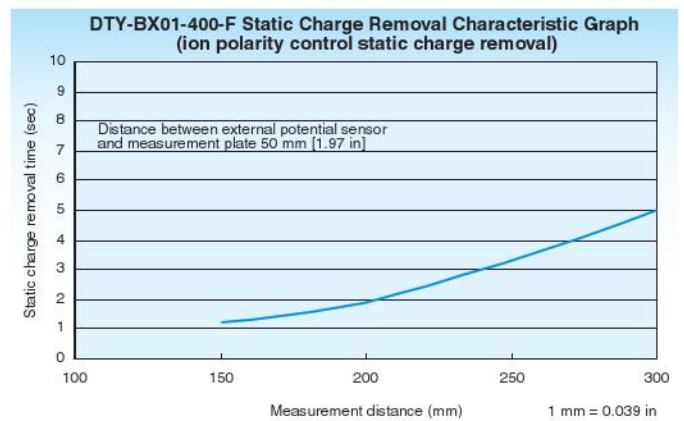
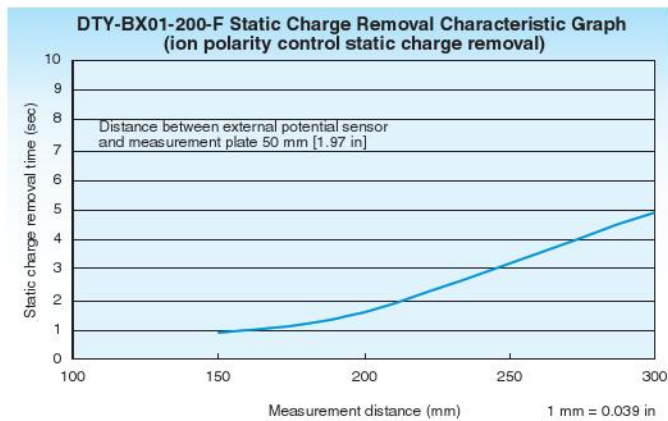
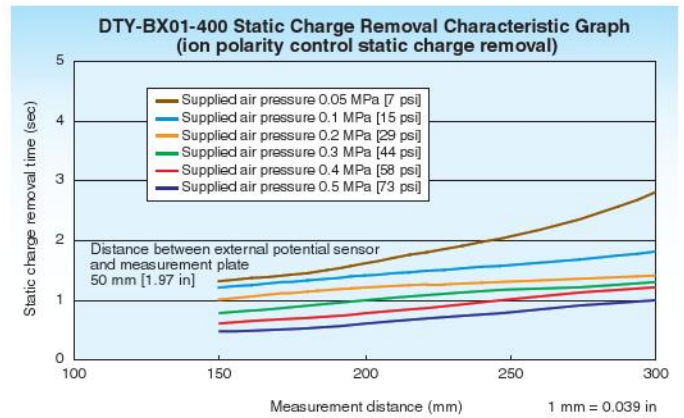
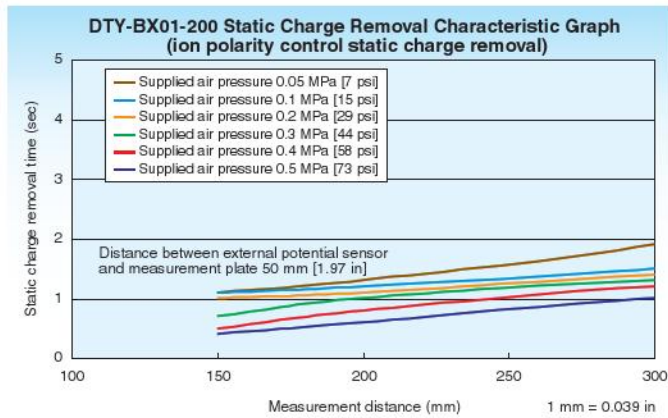

- Note 1 : Measurement performed under KOGANEI standards using a 20 pF, □150 mm [5.906 in] charged plate monitor.
- 2 : Static charge removal time is the decay time from ± 1000 V to ± 100 V.
- 3 : Static charge removal characteristics are values measured by Koganei. These values are not guaranteed.

Static Charge Removal Characteristic Graph

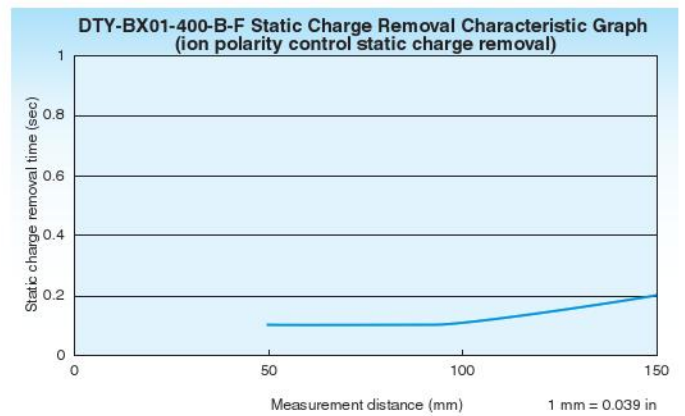
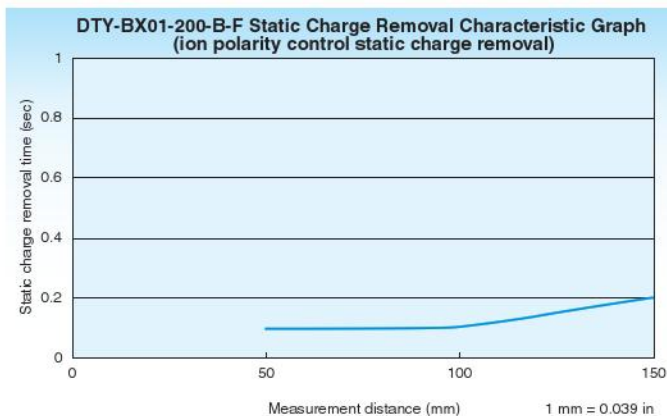
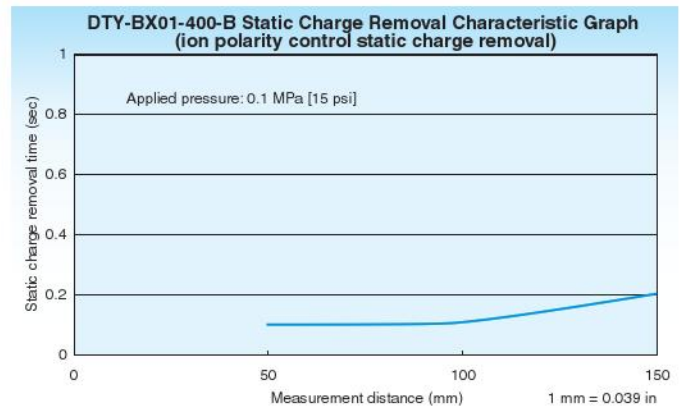
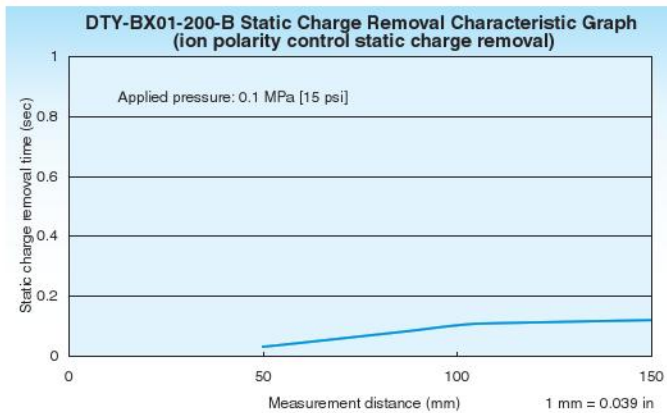
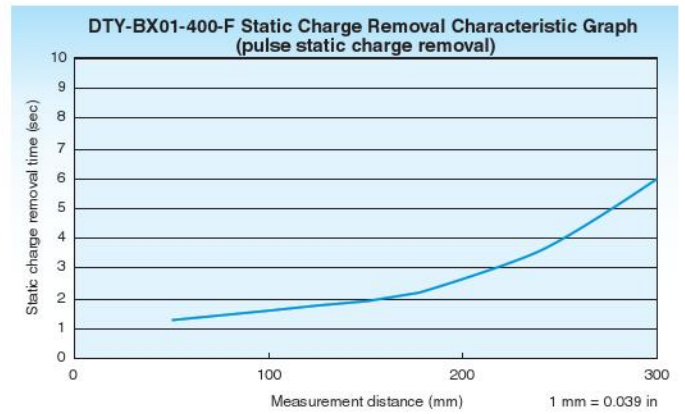
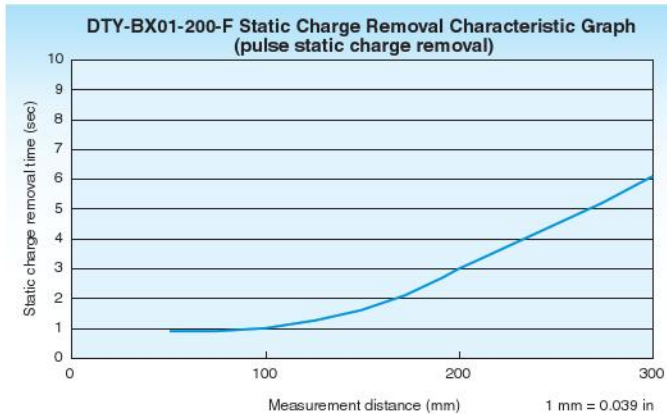
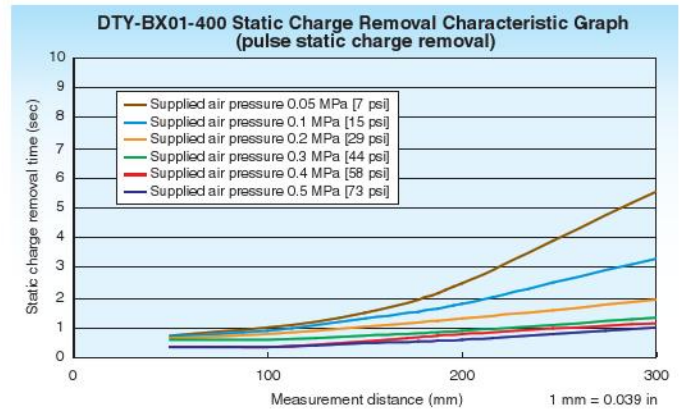
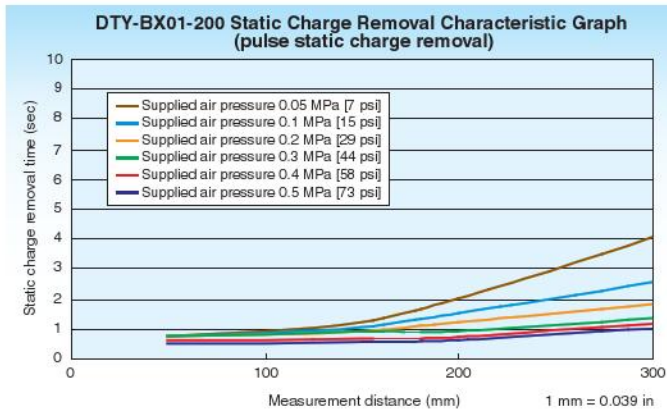

- Note 1 : Measurement performed under KOGANEI standards using a 20 pF, □150 mm [5.906 in] charged plate monitor.
 2 : Static charge removal time is the decay time from ± 1000 V to ± 100 V.
 3 : Static charge removal characteristics are values measured by Koganei. These values are not guaranteed.

Flow Rate Characteristics Graph

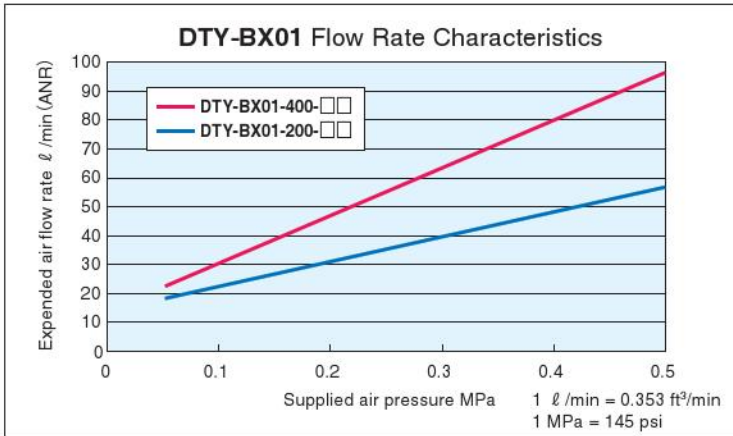

Low particle generation type particle generation volume

Measuring Conditions

- Applied pressure : 0.2 MPa [29 psi]
- Measurement time : 2 hours
- Suction volume : 1 [ft³/min]
- Measurable particles : 0.1 μm and greater

- ★1: Volume of particles generated is the volume collected in a funnel placed directly below the ionizer.
- 2: Volume of particles generated at operation time 0 was measured after 24 hours of flushing while the ionizer's power was turned off at an applied pressure of 0.2 MPa [29 psi].

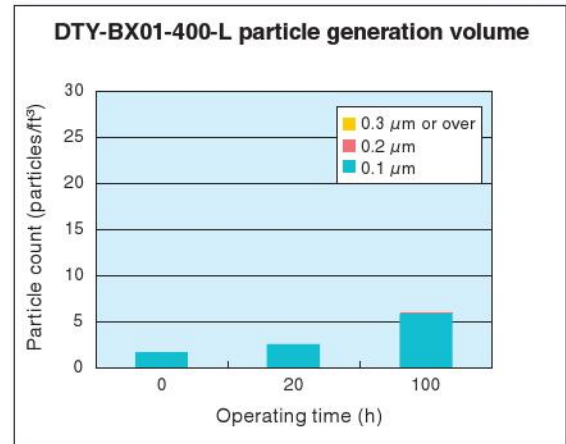
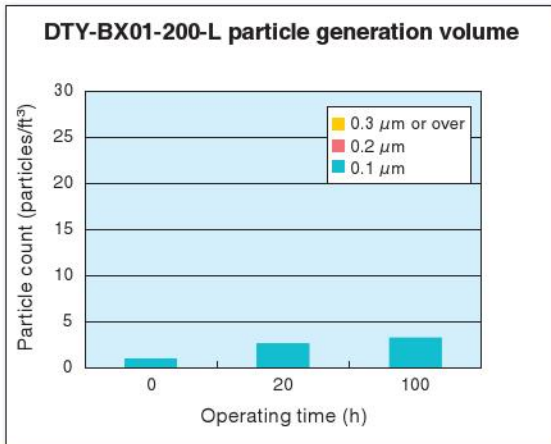

Notes 1 : Total particle generation volume over two hours is converted to 1 ft³ (28.3 ℓ).

2 : This data represents actually measured values obtained by tests performed under the conditions described above. They are not guaranteed values. The particle generation volume depends on the environment and purity of the compressed air. Carefully verify the particle generation that occurs in the environment in which the product is actually being used before using it.

memo

A series of horizontal dashed lines for writing.

Limited Warranty

KOGANEI CORP. warrants its products to be free from defects in material and workmanship subject to the following provisions.

Warranty Period The warranty period is 180 days from the date of delivery.

Koganei Responsibility If a defect in material or workmanship is found during the warranty period, KOGANEI CORP. will replace any part proved defective under normal use free of charge and will provide the service necessary to replace such a part.

Limitations

- This warranty is in lieu of all other warranties, expressed or implied, and is limited to the original cost of the product and shall not include any transportation fee, the cost of installation or any liability for direct, indirect or consequential damage or delay resulting from the defects.

- KOGANEI CORP. shall in no way be liable or responsible for injuries or damage to persons or property arising out of the use or operation of the manufacturer's product.

- This warranty shall be void if the engineered safety devices are removed, made inoperative or not periodically checked for proper functioning.

- Any operation beyond the rated capacity, any improper use or application, or any improper installation of the product, or any substitution upon it with parts not furnished or approved by KOGANEI CORP., shall void this warranty.

- This warranty covers only such items supplied by KOGANEI CORP. The products of other manufacturers are covered only by such warranties made by those original manufacturers, even though such items may have been included as the components.

The specifications are subject to change without notice.

URL <http://www.koganei.co.jp>

E-mail: overseas@koganei.co.jp



KOGANEI CORPORATION

OVERSEAS DEPARTMENT

3-11-28, Midori-cho, Koganei City, Tokyo 184-8533, Japan
Tel: 81-42-383-7271 Fax: 81-42-383-7276

KOGANEI INTERNATIONAL AMERICA, INC.

39300 Civic Center Dr., Suite 280, Fremont, CA 94538, U.S.A.
Tel: 1-510-744-1626 Fax: 1-510-744-1676

SHANGHAI KOGANEI INTERNATIONAL TRADING CORPORATION

Room 2606-2607, Tongda Venture Building No.1, Lane 600, Tianshan Road,
Shanghai, 200051, China
Tel: 86-21-6145-7313 Fax: 86-21-6145-7323

TAIWAN KOGANEI TRADING CO., LTD.

Rm. 2, 13F., No88, Sec. 2, Zhongxiao E. Rd., Zhongzheng Dist., Taipei City 100,
Taiwan (ROC)
Tel: 886-2-2393-2717 Fax: 886-2-2393-2719

KOGANEI KOREA CO., LTD.

6F-601, Tower Bldg., 1005, Yeongdeong-dong, Giheung-gu, Yongin-si, Gyeonggi-do,
446-908, Korea
Tel: 82-31-246-0414 Fax: 82-31-246-0415

KOGANEI (THAILAND) CO., LTD.

3300/90, Tower B, Elephant Tower, 16th Fl., Phaholyothin Road, Chomphon,
Chatuchak, Bangkok 10900, Thailand
Tel: 66-2-937-4250 Fax: 66-2-937-4254

KOGANEI ASIA PTE. LTD.

69 Ubi Road 1, #05-18 Oxley Bizhub, Singapore 408731
Tel: 65-6293-4512 Fax: 65-6293-4513