

Creceed Desktop Robot CELL MASTER DTRB Series

Environment friendly
RoHS directive
compliant products!

From dedication production lines to
cellular production lines!
Creating a new production concept with the
A4-size desktop factory.

Repeatability of
positioning accuracy
 ± 0.02 mm [± 0.001 in]
Compact configuration,
simple operation





Multi-variety
Variable volume
production

A4 3-axis robot with an A4 size footprint
Compact Body, Easy Operation, Flexible Use

DESKTOP ROBOT

Cell Master outstanding performance in a compact configuration creates totally new manufacturing potential.

Compact and high-performance desktop Cell Master robots revolutionize the image of the industrial robot. Based on motion technology made possible by pneumatic actuators, Koganei is constantly improving operability, general versatility, and potential for development in production sites, aimed at providing a high level of efficiency. We also provide a wide range of powerful applications that provide the versatility to respond to a variety of multi-product variable volume production cell manufacturing systems, including shorter equipment debugging times, elimination of the need for a full-time operator, lower equipment costs and more. In addition, our lineup of all-round robots are designed to fit into a variety of work sites, from industrial production lines, to workshops and hobby applications.



Shortened
equipment
debugging time



Eliminates
the need for a
full-time
operator

Lower
equipment
costs



CELL MASTER DTRB Series



Environment friendly **RoHS** directive compliant products

Simple
Style

Compact size.

Easily portable

Lightweight

Approx. **5.5** kg
[12.125 lb]

Precision slide screw drive provided

± 0.02 mm [± 0.001 in]

High accuracy

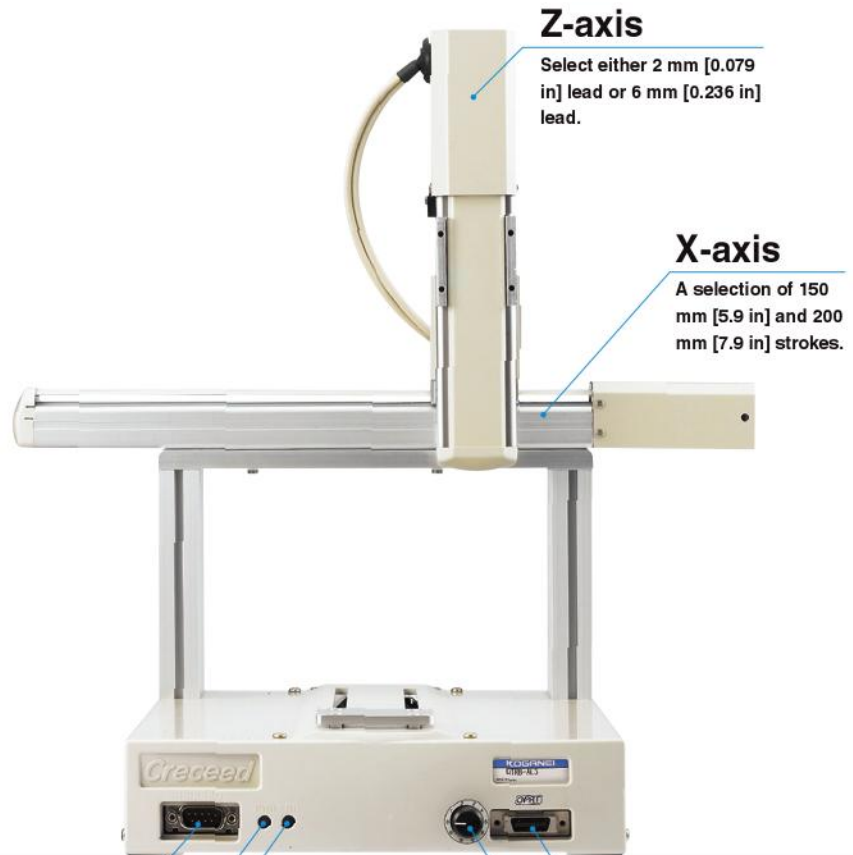

Z-axis

Select either 2 mm [0.079 in] lead or 6 mm [0.236 in] lead.

X-axis

A selection of 150 mm [5.9 in] and 200 mm [7.9 in] strokes.

RS232C connector connects to a teaching box or to an external computer.

LED light keeps you informed about control details.

Control box connector
Rotary switch (program switching)

C o m p a c t

Compactness

The main unit has an A4 footprint, allowing it to be set up almost anywhere 210 X 300 mm [8.3 X 11.8 in] (W X D) of space is available. It is suitable for work environments where space is at a premium, including one-man cell production in which a single worker operates multiple cells as well as full-fledged cell production. Furthermore, it employs precision sliding screws, enabling precise movement with a repeatability of ± 0.02 mm [± 0.001 in], and it is lightweight (5.5 kg [12.125 lb]), which makes it easy to carry and move.



Easy operation

Easy of Operation

There is no need for advanced skill. The main unit can be easily operated simply by the direct entry of operation points and parameters using the teaching box or DTRB Editor. This allows even beginners to easily use the unit and ensure stable quality. In addition, computer software with special operations programmed in advance is used, allowing you to use the main unit according to your intended purpose, including easily changing the operation program with the rotary switch, as well as perform different work concurrently by introducing multiple units.



Easy-to-operate teaching box (available separately)



One-touch control box



CAUTION

Before use, be sure to read the instruction manual that comes with the product. Also be sure to read the safety precautions on page 5.

An ideal style that allows users to realize the full potential of their ideas, and stimulates creativity.

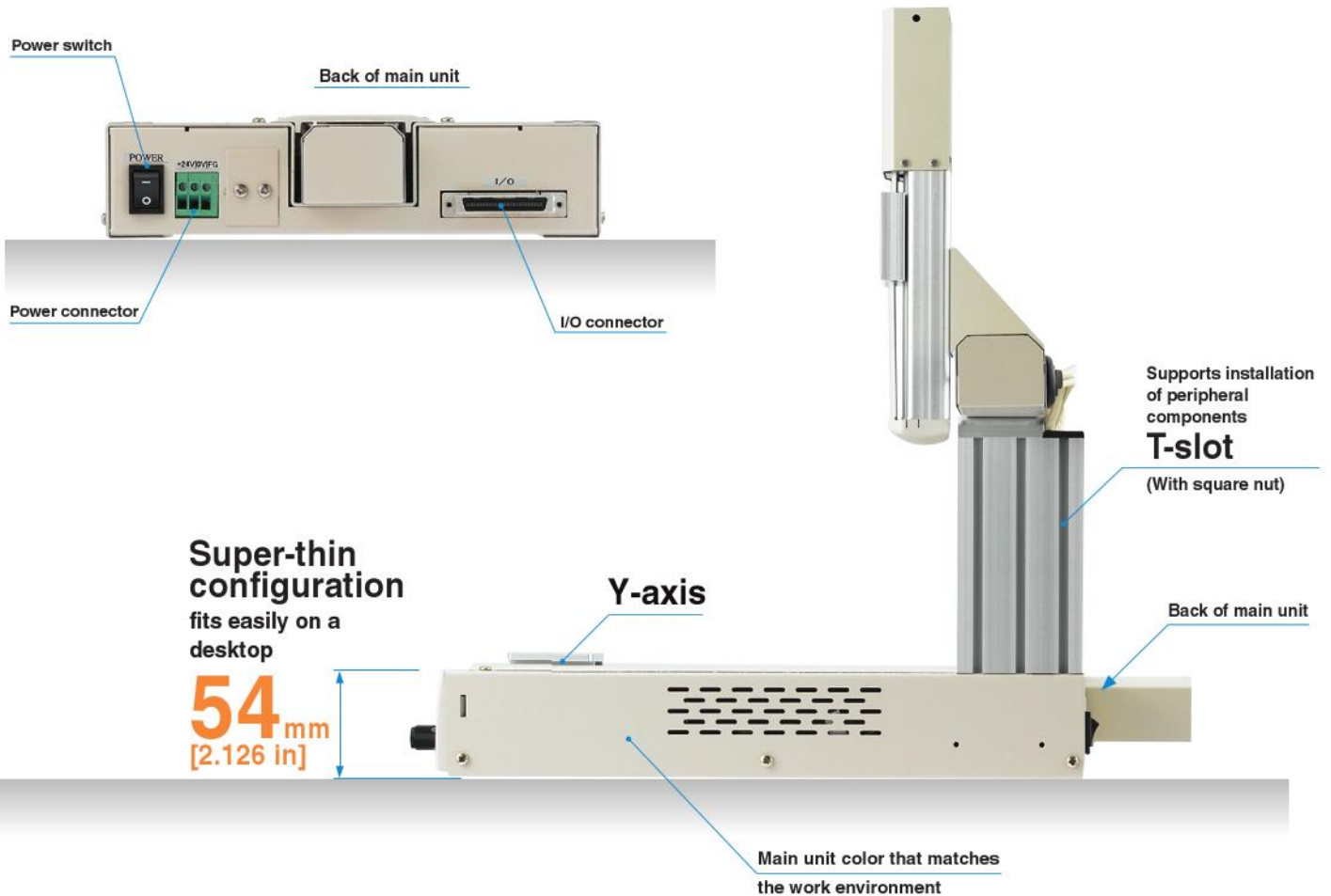

Renewal

Renewal

New teaching box

Interactive program input, coordinate input, error display

Computer communication and new editor

Input/output monitor, error display, etc.

4th axis driver equipped as standard

A rotation axis and linear motion axis are equipped in the 4th axis, enabling control by this controller. Contact Koganei separately when using a 4th axis.





Reinforced main unit rigidity

INDEX

Safety precautions	5
Main unit specification	7
Included accessories, options	9
Dimensions	11

Before selecting and using the products, please read all the safety precautions carefully to ensure proper product use. The safety precautions described below are to help you use the product safely and correctly, and to prevent injury or damage to you, other people, and assets. Be sure to comply with JIS B 8433 (safety standards for industrial robots).

The directions are ranked according to degree of potential danger or damage: **DANGER, WARNING, CAUTION, and ATTENTION**

 DANGER	Indicates situations that can be clearly predicted as dangerous. Death or serious injury may result if the situation is not avoided. It could also result in damage or destruction of assets.
 WARNING	Indicates situations that, while not immediately dangerous, could become dangerous. Death or serious injury may result if the situation is not avoided. It could also result in damage or destruction of assets.
 CAUTION	Indicates situations that, while not immediately dangerous, could become dangerous. Minor or semi-serious injury may result if the situation is not avoided. It could also result in damage or destruction of assets.
 ATTENTION	While there is no chance of injury, these points should be observed for appropriate use of the product.

- This product was designed and manufactured for use in general industrial machinery.
- When selecting and handling equipment, the system designer or another person with sufficient knowledge and experience should always read the safety precautions, catalog and other literature before commencing operation. Improper handling is dangerous.
- It is up to you to verify the fitness of compatible parts on your system, and any decisions concerning use of such parts is your responsibility.
- After reading the instruction manual, catalog, and other documentation, always store them in a location that allows easy availability for reference to users of this product.
- Whenever transferring or lending the product to another person, always attach the catalog, instruction manual, and other information, to the product where they are easily visible in order to ensure that the new user can use the product safely and properly.
- The danger, warning, and caution items listed under these safety precautions do not cover all possible contingencies. Read the catalog and instruction manual carefully, and always keep safety first.

 **DANGER**

- Do not use the product for the purposes listed below:
 1. Medical equipment related to maintenance or management of human lives or bodies
 2. Machines or equipment designed for the purpose of moving or transporting people
 3. Critical safety components in mechanical devices
 This product has not been planned or designed for purposes that require advanced stages of safety. It could cause injury to human life.
- Do not use the product in locations with or near dangerous substances such as flammable or ignitable substances. It could ignite or burst into flames.
- Do not enter the machine's operating area while the product is in operation, or in an operation-ready state. The actuator can move suddenly, possibly resulting in injury.
- Persons who use a pacemaker, etc., should keep a distance of at least 1 meter away from the product. There is a possibility that the pacemaker will malfunction due to the strong magnet built into the product.
- Always place the main unit on a flat, level, and sturdy surface and ensure there is adequate working space around it. Dropping or falling of the product or improper operation could result in injury.
- Never attempt to remodel the product. It could result in abnormal operation leading to injury, electric shock, fire, etc.
- Never attempt inappropriate disassembly, assembly of the product relating to basic construction, or to its performance or to functions. Doing so creates the risk of injury, electric shock, fire, etc.
- Do not splash water on the product. Spraying water on the product, washing the product, or using the product under water creates the risk of malfunction, leading to injury, electric shock, fire, etc.

 **WARNING**

- Do not use the product in excess of its specification range. Such use could result in product breakdowns, function stop, damage, or drastically reduce the operating life.
- Use safety circuits or design a system that prevents damage to machinery and personal injury when the machine is shut down due to an emergency stop or electrical power failure.
- Always implement D-class grounding work (ground resistance 100Ω or less). Current leakage could cause electric shock or erratic operation.

- Before supplying electricity to the device and before starting operation, always conduct a safety check of the area where the machine is operating. Unintentional supply of electricity creates the risk of electric shock or injury due to contact with moving parts.
- Do not touch the terminals and the miscellaneous switches, etc., while the device is powered on. There is a possibility of electric shock and abnormal operation.
- Avoid scratching the cords of cables, etc. Letting the cords be subject to scratching, excessive bending, pulling, rolling up, or being placed under heavy objects or squeezed between two objects, may result in current leaks or defective continuity that could lead to fire, electric shock, or abnormal operation.
- If abnormal noise occurs or vibrations are excessive, immediately cease operation. Continued use in this condition may result in abnormal operation or runaway that could lead to product damage or destruction.
- Do not throw the product into fire. The product could explode and/or release toxic gases.
- Do not sit on the product, place your foot on it, or place other objects on it. Accidents such as falling and tripping over could result in injury. Dropping the product may result in injury, or it might also damage or break it, resulting in abnormal or erratic operation, runaway, etc.
- For inspection, maintenance, replacement, or other kinds of operations related to the product, always completely turn off the power supply before beginning.

 **CAUTION**

- When transporting or installing the product, support it securely with a lift or support tool, and avoid injuries by having multiple people, etc., do the work.
- Do not use the product in locations that are subject to direct sunlight (ultraviolet rays), dust, salt, iron powder, high humidity, or in the media and/or the ambient atmospheres that include organic solvents, phosphate ester type hydraulic oil, sulphur dioxide, chlorine gas, acids, etc. It could lead to an early shutdown of some functions or a sudden degradation of performance, and result in a reduced operating life.
- Do not use the product in atmospheres subject to corrosive gases, flammable gases, flammable liquids, etc. It could lead to a decrease in strength due to rust, or to a risk of the motor igniting or the product exploding.

- If using the product in the locations listed below, implement adequate shielding measures.
Failure to take these measures may lead to erratic operation:
 1. Locations subject to large electric current or magnetic fields
 2. Locations subject to noise due to static electricity, etc.
 3. Locations with the possibility of exposure to radiation
- Do not bring magnetic media, etc., within 1 meter of the product.
There is a possibility that the data in the magnetic media will be destroyed due to the magnetism of the magnet built into the product.
- Install the main unit in locations with as little dust or dirt as possible.
Installation in locations subject to lots of dust or dirt can lead to erratic operation.
- Do not install the product in locations subject to heavy vibrations (4.9 m/s² [0.5 G] or more).
Transmission of heavy vibrations to the product could lead to erratic operation.
- When installing the product, leave room for adequate working space around it. Failure to ensure adequate working space will make it more difficult to conduct daily inspections or maintenance, which could eventually lead to system shutdown or damage to the product.
- Do not scratch, dent, or deform the driving portion by climbing on the product, using it as a scaffold, or placing objects on it. It could lead to damaged or broken products that result in operation shutdown or degraded performance.
- Always post an "operations in progress" sign for installations, adjustments, or other operations, to avoid unintentional supplying of electrical power, etc. Such accidental supplies may cause electrical shock, or sudden activation of the actuator that could result in physical injury.



ATTENTION

- When considering the possibility of using this product in situations or environments not specifically noted in the Catalog or Owner's Manual, or in applications where safety is an important requirement such as in an airplane facility, combustion equipment, leisure equipment, safety equipment, and other places where human life or assets may be greatly affected, take adequate safety precautions such as an application with enough margins for ratings and performance or fail-safe measure. Be sure to consult us about such applications.
- Use a protective cover, etc., to ensure that the operating portions of mechanical devices, etc., are isolated and do not come into direct contact with human bodies.
- Do not control the product in a way that would cause a workpiece to fall during a power failure. Take control measures so that they prevent the table and the workpiece, etc., from falling during a power failure or an emergency stop of the mechanical devices.
- Always check the Owner's Manual and other reference materials for product wiring.
- When handling the product, wear protective gloves, safety glasses, safety shoes, etc., to keep safety.
- When the product can no longer be used, or is no longer necessary, dispose of it appropriately as industrial waste.
- For inquiries about the product, consult Koganei Overseas Department. The telephone number is shown on the back cover of this owner's manual.



Other

- Always observe the following items.
 1. When using this product in a system, use only genuine Koganei parts or compatible parts (recommended parts).
Use only authentic Koganei parts or compatible parts (recommended parts) to do maintenance or repairs.
Always observe the prescribed methods and procedures.
 2. Never inappropriately disassemble or modify the product in relation to its basic construction, performance, or functions.

Koganei cannot be held responsible for any problems that occur as a result of these safety precautions not being properly observed.

Handling instructions and precautions



CAUTION

Read these precautions carefully before use.

Mounting

Read the precautions below for better table linear motion accuracy and to ensure smooth sliding screw movement.

1. Locate the main unit on a surface that is level, flat, and stable.
2. To obtain rigidity of the robot, be sure to provide an adequately large setup and mounting area.

Environment

1. Avoid use in locations where there is the chance of water droplets, oil droplets, or other liquids getting onto the main unit, where large amounts of dust are present.
2. Avoid use in locations where sulfur dioxide, hydrochloric acid, or other corrosive gases are generated.
3. Avoid locations subjected to strong vibration and/or impact.

Other

Before use, be sure to read the instruction manual that comes with the product.

Main unit

3-axis gantry type
DTRB-AL3



3-axis Cartesian type
DTRB-CS3



2-axis gantry type
DTRB-AL2



2-axis Cartesian type
DTRB-CS2



Main unit specification

Main unit type		DTRB-AS2	DTRB-AS3	DTRB-ASL3	DTRB-AL2	DTRB-AL3	DTRB-ALL3	DTRB-CS2	DTRB-CS3	DTRB-CSL3
Operating range (mm [in])	X	150 [5.9]	150 [5.9]	150 [5.9]	200 [7.9]	200 [7.9]	200 [7.9]	100 [3.9]	100 [3.9]	100 [3.9]
	Y	200 [7.9]	200 [7.9]	200 [7.9]	200 [7.9]	200 [7.9]	200 [7.9]	200 [7.9]	200 [7.9]	200 [7.9]
	Z	—	50 [1.969]	50 [1.969]	—	50 [1.969]	50 [1.969]	—	50 [1.969]	50 [1.969]
Drive system method	X·Y·Z	2-phase stepping motor (micro step drive)								
Drive mechanism	X·Y·Z	Slide screw drive								
Maximum speed (mm/s [in/sec])	X·Y	200 [7.9]	200 [7.9]	200 [7.9]	200 [7.9]	200 [7.9]	200 [7.9]	200 [7.9]	200 [7.9]	200 [7.9]
	Z	—	200 [7.9]	70 [2.756]	—	200 [7.9]	70 [2.756]	—	200 [7.9]	70 [2.756]
Repeatability (mm [in])	X·Y·Z	± 0.02 [± 0.001]	± 0.02 [± 0.001]	± 0.02 [± 0.001]	± 0.02 [± 0.001]	± 0.02 [± 0.001]	± 0.02 [± 0.001]	± 0.02 [± 0.001]	± 0.02 [± 0.001]	± 0.02 [± 0.001]
Maximum payload- Note5 (kg [lb])	X·Y	2 [4.409]	2 [4.409]	2 [4.409]	2 [4.409]	2 [4.409]	2 [4.409]	2 [4.409]	—	—
	Z	—	1 [2.205]	2 [4.409]	—	1 [2.205]	2 [4.409]	—	1 [2.205] ^{Note1}	1 [2.205] ^{Note1}
Leads (mm [in])	X·Y	6 [0.236]	6 [0.236]	6 [0.236]	6 [0.236]	6 [0.236]	6 [0.236]	6 [0.236]	6 [0.236]	6 [0.236]
	Z	—	6 [0.236]	2 [0.079]	—	6 [0.236]	2 [0.079]	—	6 [0.236]	2 [0.079]
Interpolation speed (m/s [ft/sec]) (Constant linear speed) ^{Note6}	Straight line (Linear)	0.45 ~ 45 [0.018 ~ 1.772] ^{Note2}								
	Circle	0.15 ~ 15 [0.006 ~ 0.591]								
	Continuous	0.15 ~ 15 [0.006 ~ 0.591]								
Axis control system	Number of control axes	Simultaneous 3-axis control + 1-axis independent control (4th axis)								
	Position setting unit	mm setting								
	Operation system	PTP operation, CP operation								
	Interpolation function	3-axis linear interpolation, 2-axis circular interpolation, 2-axis continuous interpolation								
Program	Position control	Open loop								
	Programming method	Code type								
	Number of programs	6 groups								
	Number of steps per program	1000 steps								
Point input method	Number of points	1 step 1 point ^{Note3}								
	Manual data input (coordinate input) using teaching box; Off-line programming by teaching playback, and computer									
Input/output	I/O	16 points each for input and output (15 points for general-purpose input, custom input Start, 13 points for general-purpose output, and custom output READY, BUSY, and PALLET)								
	External connection	RS232C connector (for both teaching box and PC), operation box connector, and I/O connector								
	COMM port (transmission rate)	RS232C(19.2kbps)								
General specifications	Power supply	24VDC ± 10% (No DC power supply is provided. A 24VDC 3A 75W or more external power supply is required.) ^{Note4}								
	Operating temperature	0 ~ 40°C [32 ~ 104°F]								
	Operating humidity	35 ~ 90% (no condensation)								
	Storage temperature	-10 ~ 50°C [14 ~ 122°F]								
Mass		Approx. 5 kg [11.023 lb]	Approx. 5.5 kg [12.125 lb]	Approx. 5.5 kg [12.125 lb]	Approx. 5.2 kg [11.464 lb]	Approx. 5.7 kg [12.566 lb]	Approx. 5.7 kg [12.566 lb]	Approx. 5.4 kg [11.905 lb]	Approx. 5.9 kg [13.007 lb]	Approx. 5.9 kg [13.007 lb]

Note 1: Point setting must allow for Y-axis deflection.

Note 2: Linear interpolation speed is 0.15 to 15 mm/s [0.006 to 0.591 in/sec] including a 2 mm [0.079 in] lead.

Note 3: The CIRCLE command is 2 steps and 3 points.

Note 4: Set the power capacity according to the current consumption of external output. (250 mA max. per output, but keep the total for 16 points at 2 A or less.)

Note 5: Workpiece mount

Note 6: Linear speed is not uniform at axis speeds of 0.1 mm/s [0.004 in/sec] or lower.

● Main unit order codes

		Gantry type						Cartesian type		
		DTRB-AS2	DTRB-AS3	DTRB-ASL3	DTRB-AL2	DTRB-AL3	DTRB-ALL3	DTRB-CS2	DTRB-CS3	DTRB-CSL3
X-axis stroke		150 mm [5.9 in]			200 mm [7.9 in]			100 mm [3.9 in]		
Number of axis	2-axis	●			●			●		
	3-axis		●	●		●	●		●	●

Remark: The DTRB Series is equipped with a 4th axis driver as standard.

System configuration

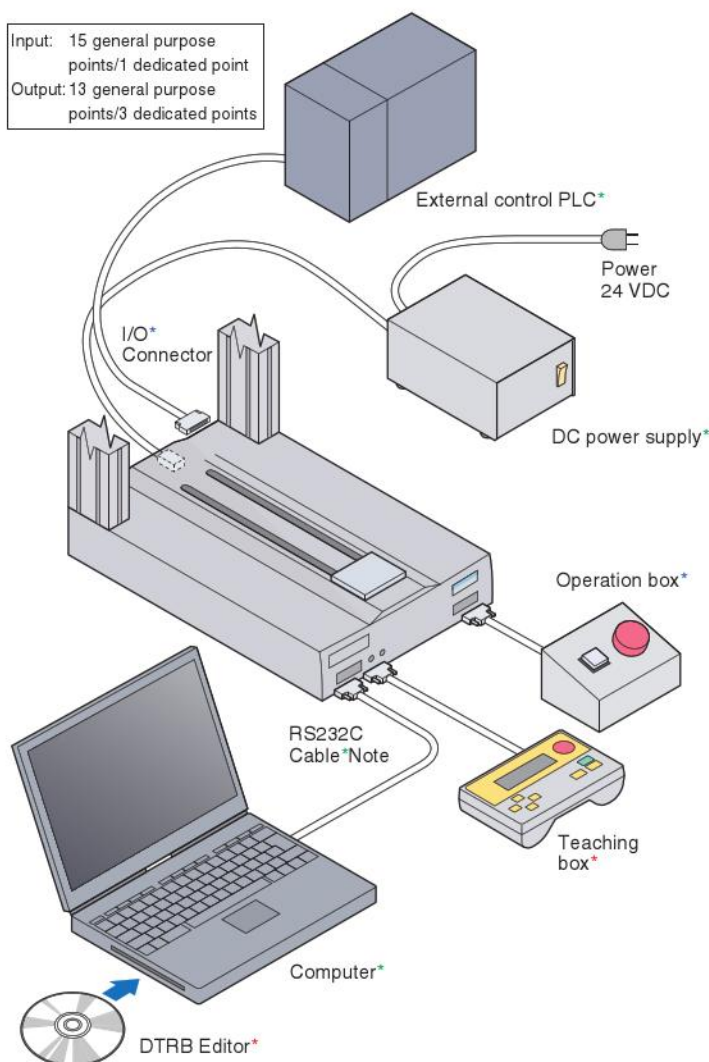

Command list

Command	Second	Data	Description
POINT	0* *	Point	XY→Z movement
POINT	1* *	Point	ZI (virtual position) →XY→Z movement
POINT	2* *	Point	ZO (origin position) →XY→Z movement
POINT	3* *	—	ZI (virtual position) movement
POINT	4* *	—	ZO (origin position) movement
POINT	5* *	—	Origin return to origin movement
POINT	6* *	Point	R-axis movement
POINT	7* *	Point	XYZ (absolute) movement
POINT	8* *	Point	XYZ (increment) movement
LINE	0* *	Point	Linear interpolation movement
LINE	100	—	Continuous interpolation start
LINE	200	—	Continuous interpolation end
LINE	4* *	Point	R-axis linear interpolation
CIRCLE	000	Point	Circular movement
PALET	0* *	—	Palette (number*) movement
PALET	1* *	—	Palette (number*) count up output
PALET	2* *	—	Palette (number*) count reset
SEQ	0* *	—	Wait for IN* * ON
SEQ	1* *	—	Wait for IN* * OFF
SEQ	2* *	—	OUT* * ON
SEQ	3* *	—	OUT* * OFF
SEQ	4* *	—	Timer setting
SEQ	6* *	J=##	IN* * jump to condition ON step No ##
SEQ	7* *	J=##	IN* * jump to condition OFF step No ##
SEQ	8* *	J=##	Unconditional jump to step No ##
SEQ	9* *	J=##	IN* * CALL jump to ON step No ##
SEQ	916	J=##	Unconditional CALL jump to step No ##
SEQ	917	—	Return
END	000	—	Unconditional program end
END	100	—	Stop by END step following 1-cycle operation
END	200	—	Repeat operation

*Attachments/accessories

* Option (sold separately)

* Items to be prepared by you.

Note: RS232C cable (reference)

Specification: D-sub9pin female D-sub9pin female•Cross cable

Type: C232R-915(1.5 m [4.921 ft])/ C232R-930 (3.0 m [9.843 ft])

Manufacturer: Elecom

Note: A mold type connector cannot be used because its large shape can interfere with the cell master main unit cover.

Accessories, options

● Accessories

Operation box

DTHBM-OB (Cable length: 1 m [3.281 ft])



Keep operation start, pause, return to origin, and emergency stop at your fingertips.

I/O connector

DTRBM-CT

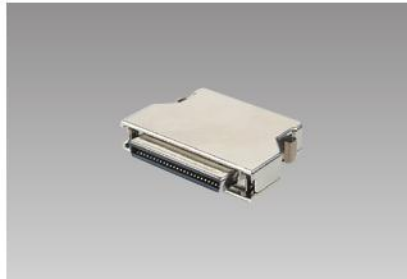

Connector for connecting to a computer, solenoid valve, relay, or other external equipment.

■ Dimensions mm [in]

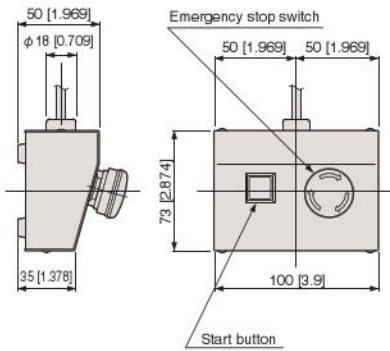

● Options

Teaching box

DTRBP-TB (Cable length: 3 m [9.843 ft])



Simple parameter setting configuration and program input operations.

■ Dimensions mm [in]

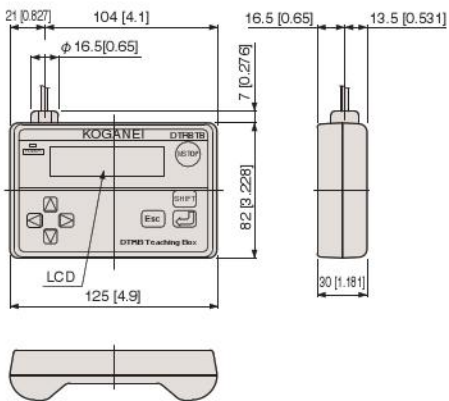

Support software

DTRB Editor

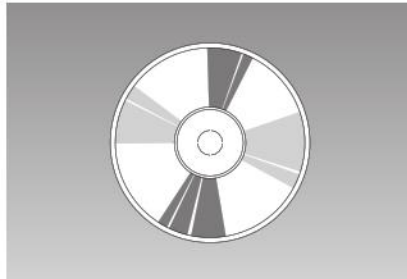

This is a support tool for a computer that is already programmed with special-purpose operations.

DTRBP-SW-HTA (Japanese)

DTRBP-SW-HTC (English)

(Supported operating systems: **Windows 95, 98, Me, NT, 2000, XP**)

* Windows is a registered trademark of Microsoft Corporation of the United States.

**Gantry
2-axis**

DTRB-AS2

X-axis: 150 mm [5.9 in]

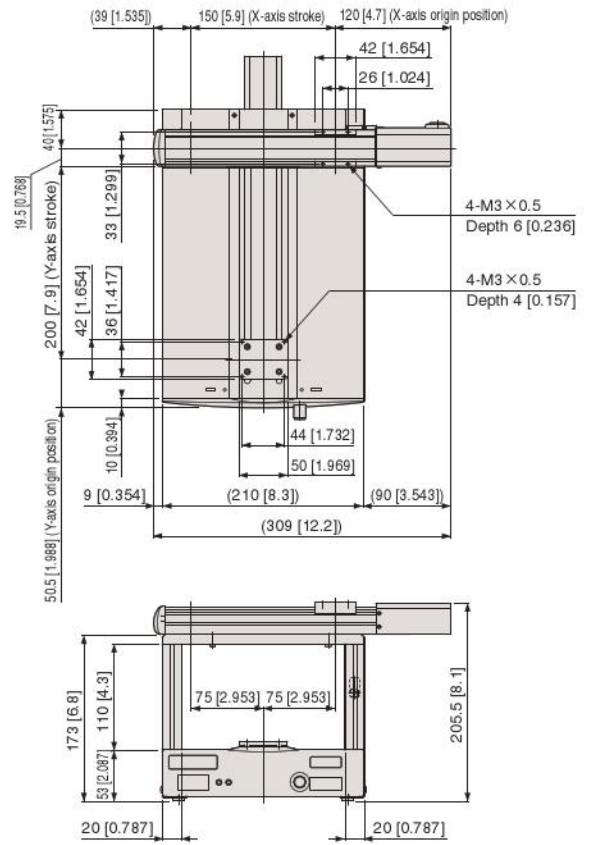
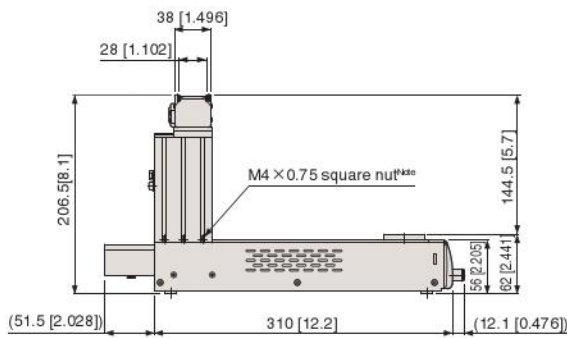

Note: A total of eight square nuts on both stand sides and back.

**Gantry
3-axis**

DTRB-AS3

DTRB-ASL3

X-axis: 150 mm [5.9 in]

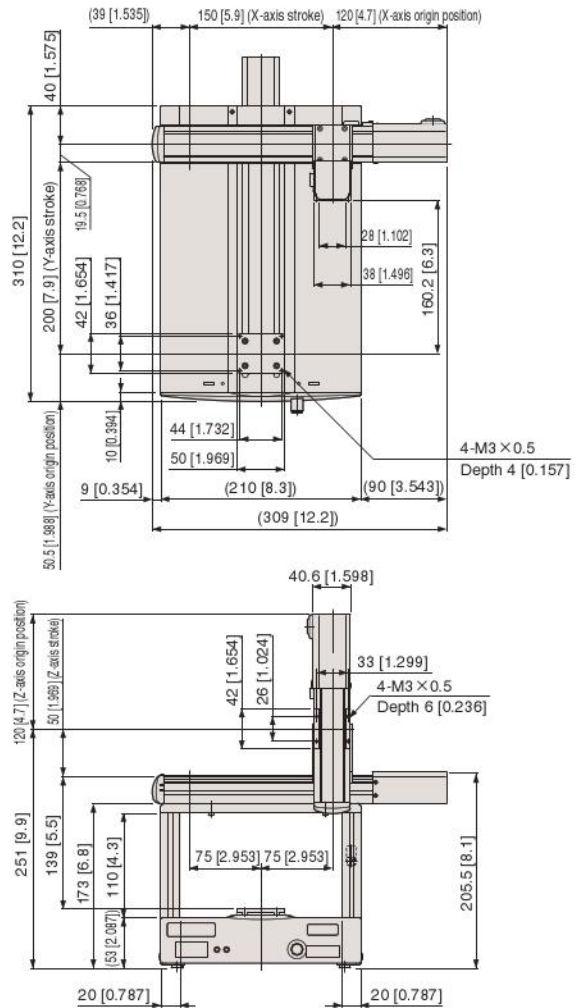
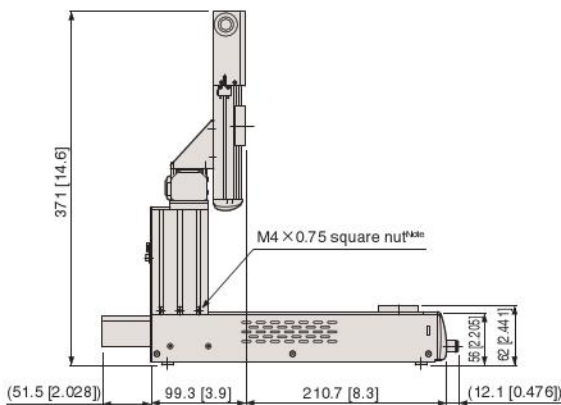

Note: A total of eight square nuts on both stand sides and back.

Gantry 2-axis

DTRB-AL2

X-axis: 200 mm [7.9 in]

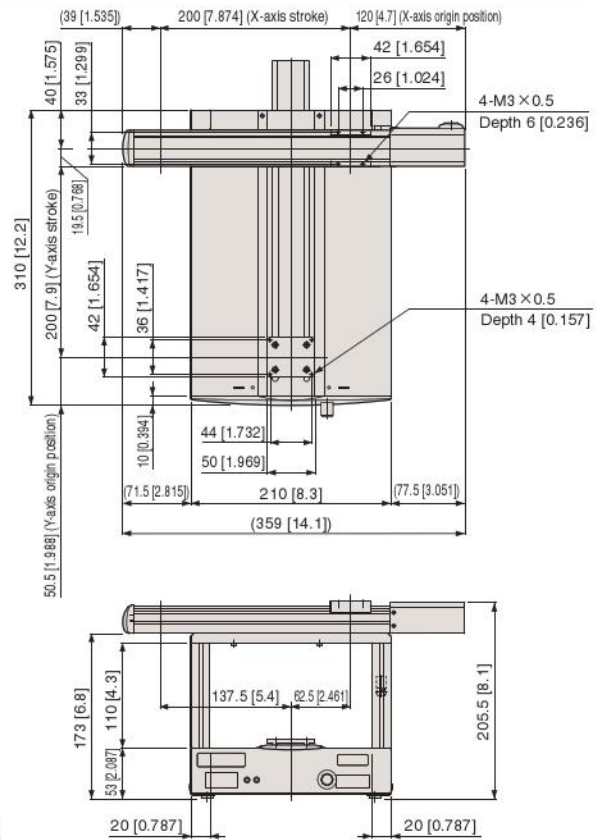
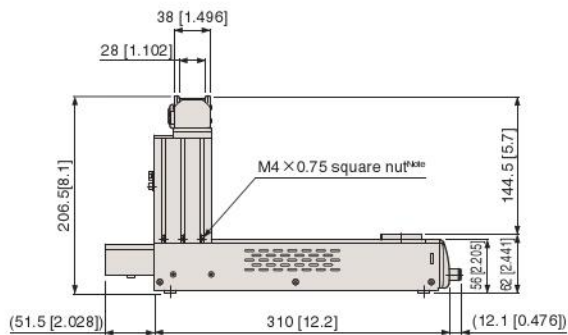

Note: A total of eight square nuts on both stand sides and back.

Gantry 3-axis

DTRB-AL3 DTRB-ALL3

X-axis: 200 mm [7.9 in]

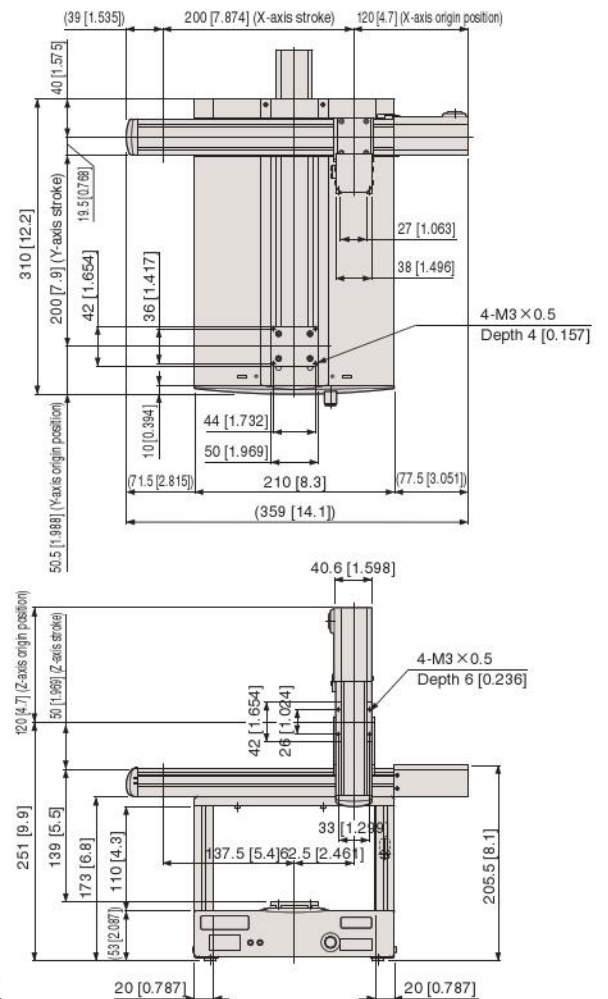
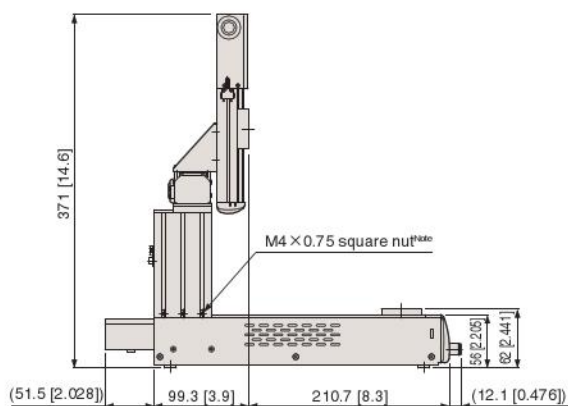

Note: A total of eight square nuts on both stand sides and back.

Dimensions (Unit: mm [in])

Cartesian
2-axis

DTRB-CS2

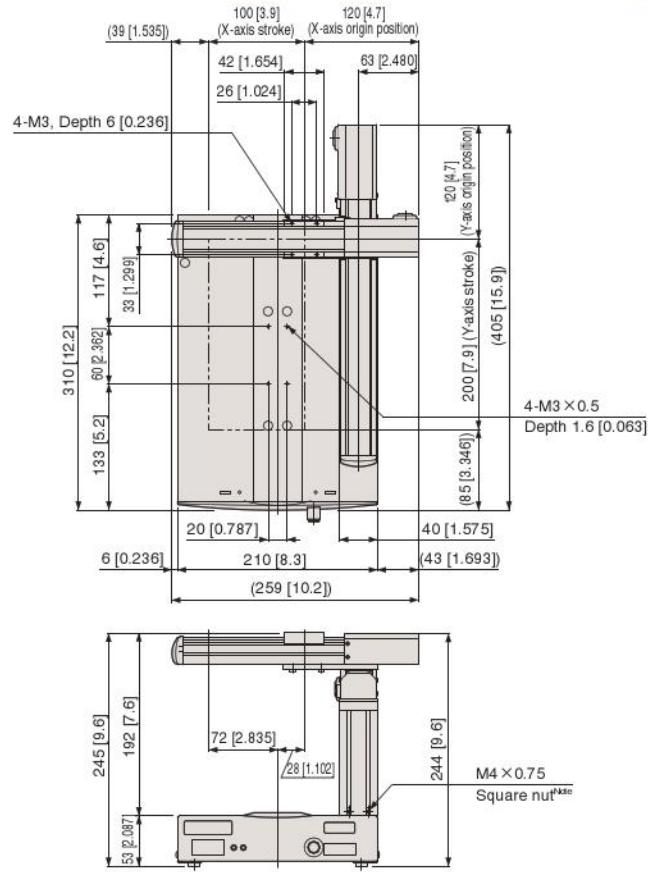
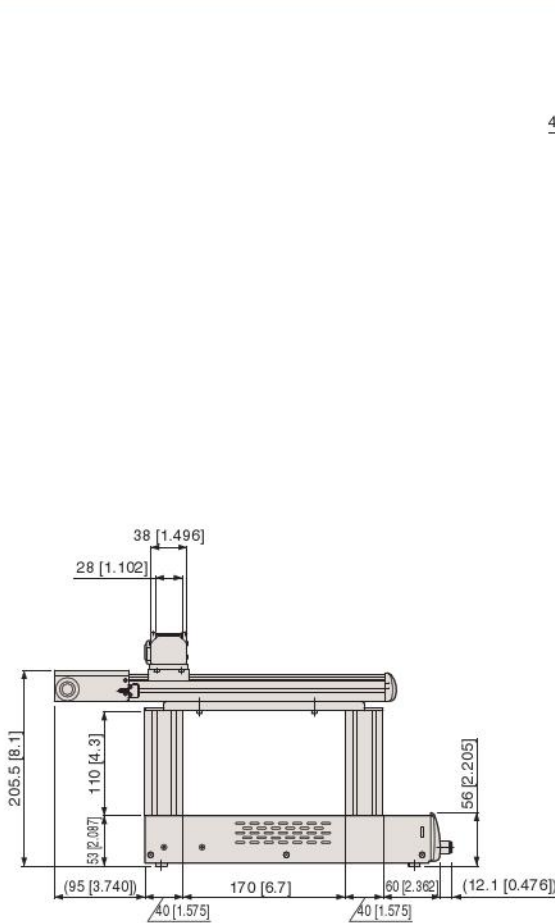

Note: A total of eight square nuts on stand front, back, and right side.

Cartesian
3-axis

DTRB-CS3
DTRB-CSL3

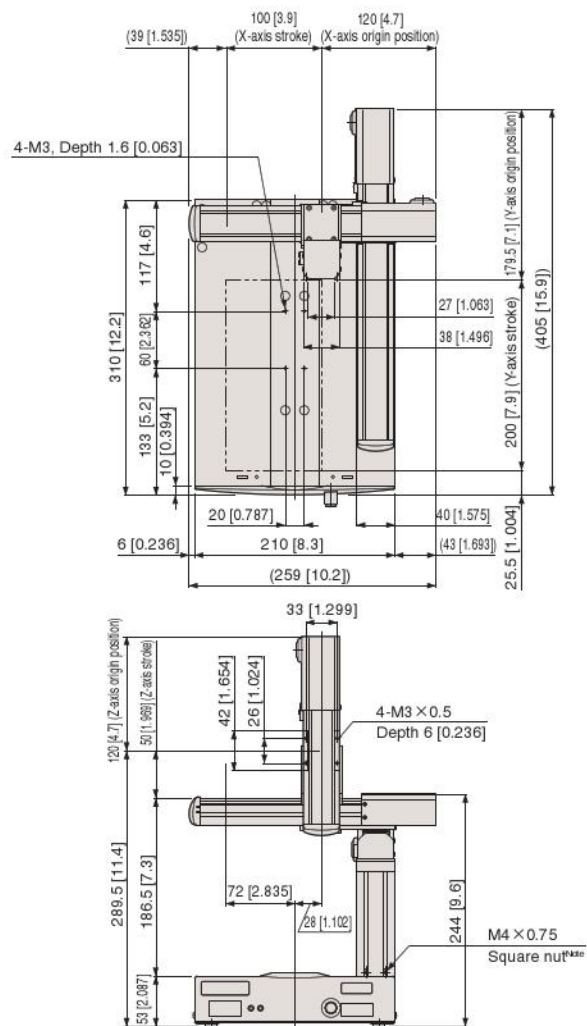
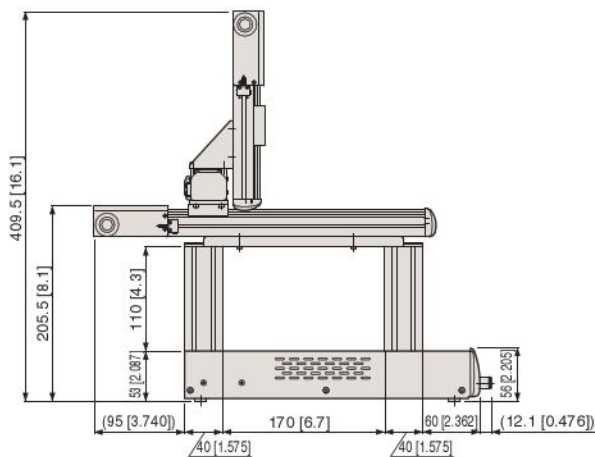

Note: A total of eight square nuts on stand front, back, and right side.

Overview of changes by renewal of DTR - DTRB

- The main changes resulting from renewal from the DTR Series to the DTRB Series are shown below.
For details about DTRB Series specifications and functions, refer to the instruction manual.

Changed item	DTR	DTRB
Motor cable and connector	Controller unit external connection	Controller unit internal connection
	External wiring	Main unit internal and sand internal wiring
DIP switches for program selection	Control box	Main unit front
Position of control box mounting connector	Main unit back	Main unit front
RS232C connector (communication cable)	Female (male-female straight cable)	Male (female-female cross cable)
Power	Dedicated power supply box	Use of commercially available power supply
Power switch position	Dedicated power supply box	Main unit back
Aluminum frame stand (gantry type)	Cross-sectional type 20 × 40	Cross-sectional type 20 × 60
4th axis driver	3-axis standard, 4th axis mounted separately	4-axis standard
Driver drive method	Half-step drive	Micro step drive
Motion control (vibration suppression)	Trapezoidal control	Trapezoidal control/ S-curve control
Gantry type Y-axis stroke	180 mm [7.1 in]	200 mm [7.9 in] (top cover change)
Communication speed	9600bps	19200bps
Teaching box	Dedicated keys and 7-segment LED display	Inter-active selection and LCD display
Value input from teaching box	No	Yes
Current position indication	No	Yes
Offset function	Teaching box operation	Parameter settings
Counter reset function	Control box operation	Teaching box operation, command PALET2* *
Communication output on error generation	No	Yes
Number of circle (circular interpolation) steps	1 step	2 steps
Control of number of continuous linear interpolations	4 linear interpolations, 4 circular interpolations	No control
Jump destination change when step is inserted or deleted	Re-input task	Auto editing
Motor cover length	70 mm [2.8 in]	78 mm [3.1 in]