



CAD drawing data catalog
is available.



KOGANEI

ACTUATORS GENERAL CATALOG

LOW-PRESSURE CYLINDERS INDEX

Features	1375
Safety Precautions	1376
Handling Instructions and Precautions	1376
DJ Cylinders	
Specifications	1377
Dimensions of Double Acting Type	1381
Dimensions of Single Acting Push Type	1386
DF Cylinders	
Specifications	1391
Dimensions	1393
Sensor Switches	1394

Discontinued



Caution

Before use, be sure to read the "Safety Precautions" on p. 45.

LOW-PRESSURE CYLINDERS

BF diaphragm

DJ cylinders



- **Double acting type:** $\phi 20$ [0.787in.], $\phi 32$ [1.260in.], $\phi 40$ [1.575in.], $\phi 50$ [1.969in.]
- **Single acting push type:** $\phi 20$ [0.787in.], $\phi 32$ [1.260in.], $\phi 40$ [1.575in.]

- A precision control cylinder that uses a BF diaphragm.
- Air leaks almost never occur with the BF diaphragm seal.
- Excellent follow-up performance for pressure fluctuations.
Can operate even under micro-pressures (0.02MPa [3psi.]^{Note}).

Note: For sizes other than $\phi 20$ [0.787in.], the pressure is 0.015MPa [2psi.].

- Operating principles (DJ cylinder, single acting type)

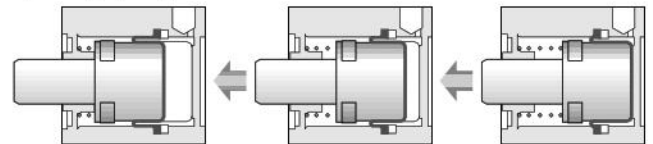

Diaphragm

DF cylinders



- **Non-rotating single acting push type:** $\phi 12$ [0.472in.], $\phi 20$ [0.787in.], $\phi 30$ [1.181in.], $\phi 40$ [1.575in.]

- A thin and lightweight cylinder for precision control.
- Air leaks almost never occur with the diaphragm seal.
- With no sliding portion open to the air, solid particles are eliminated.

Application example

1 Tension control

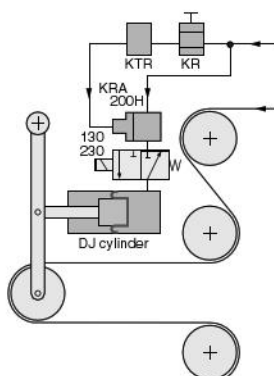

Equipment applications: Printing equipment, paper plant equipment, plastic film processors, textile machines, grinders, etc.

2 Pressure control (grinders)

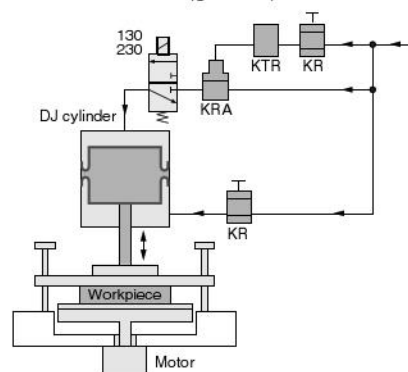

Remark: Optimum precision regulators KR series and electro-pneumatic transducing regulators KTR series are available for control the DJ cylinders and DF cylinders. For details, see the General Catalog of Air Treatment, Auxiliary, Vacuum.

Safety Precautions

Warning

Listed below are safety precautions specifically for the DJ Cylinders and DF Cylinders. For general safety precautions, be sure to read p.45.

- Do not apply lateral loads to the rod. It could cause increase of sliding friction, deterioration in bearing operating life, and early rupture of the diaphragm.
- Install an external stopper to ensure that the piston does not impact against the body.
- Use within the recommended load and specified speed ranges. Use in excess of the recommended load and specified speed could cause the piston rod or plate to pop up, damaging equipment or causing personal injury.

Handling Instructions and Precautions



General precautions

1. Always thoroughly blow off (use compressed air) the tubing before piping. Entering metal chips, sealing tape, rust, etc., generated during piping work could result in air leaks or other defective operation.
2. Use air for the media. For the use of any other media, consult us.
3. Air used for the cylinder should be clean air that contains no deteriorated compressor oil, etc. Install an air filter (filtration of 40µm or less) near the cylinder or valve to remove collected liquid or dust. In addition, drain the air filter periodically. Collected liquid or dust entering the cylinder may cause in improper operation.



Mounting and piping

1. For the DJ cylinder, do not attempt to move the piston rod when air is not being applied. The BF diaphragm inside the cylinder will be slack and become snagged.
2. If using the double acting type DJ cylinder in a vertical position, take the following measures.
When the piston rod is facing upward, always design the equipment that allows air to be supplied such that the piston rod retracted when completed the operation. When, on the other hand, the piston rod is facing downward, always design the equipment that allows air to be supplied such that the piston rod extended when completed the operation.
Attempting to move the piston rod when air pressure is not being applied will cause the BF diaphragm inside the cylinder to be slack and become snagged.
3. When mounting the DJ cylinder or DF cylinder, or when doing piping work, tighten mounting bolts at the tightening torques shown below.

●DJ cylinder mounting bolt tightening torque

Thread size	Tightening torque N·m {kgf·m} [ft·lbf]
M5×0.8	2.9 [0.3] [2.1]
M6×1	4.4 [0.45] [3.2]
M8×1.25	10.8 [1.1] [8.0]

Caution: Do not attempt to rotate the rods or tighten threads while air is supplied to the cylinder. The internal BF diaphragm could become twisted and break. When tightening the threads, always use wrench flats (width across flats) to hold the rod in place, at no applying air pressure.

●DF cylinder mounting bolt tightening torque

Thread size	Tightening torque N·m {kgf·m} [ft·lbf]
M3×0.5	0.6~0.8 {0.06~0.08} [0.4~0.6]
M4×0.7	1.2~1.4 {0.12~0.14} [0.9~1.0]
M5×0.8	2.5~2.7 {0.25~0.28} [1.8~2.0]

Caution: Although the DF cylinder employs a non-rotating construction, use wrench flats (width across flats) to ensure that no load is applied to the piston rod. If not, the non-rotating portion could be damaged, obstructing normal operations.

●DJ cylinder, DF cylinder piping tightening torque

Port size	Tightening torque N·m {kgf·m} [ft·lbf]
M5×0.8	1.6 [0.16] [1.2]
Rc 1/8	6.8~ 8.6 {0.69~0.88} [5.0~6.3]
Rc 1/4	11.6~13.4 {1.18~1.37} [8.6~9.9]

Discontinued

DJ CYLINDERS

Double Acting Type, Single Acting Push Type

Features

- A precision control cylinder that uses a BF diaphragm.
- Air leaks almost never occur with the BF diaphragm's perfect seal.
- Excellent follow-up performance for pressure fluctuations. Can operate even under micro-pressures (0.015MPa [2psi.]^{Note}).

Note: $\phi 20$ [7.87in.]:0.02MPa [3psi.]



Symbols

- Double acting type
- Single acting push type

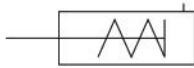
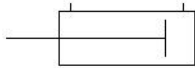

Specifications

Item	Bore size mm [in.]	20 [0.787]	32 [1.260]	40 [1.575]	50 [1.969]
		Double acting type, single acting push type			Double acting type
Operating type		Double acting type, single acting push type			Double acting type
Media		Air			
Mounting type		Basic type	Basic type, Foot mounting type, Axial foot mounting type, Rod/head side flange mounting type		
Operating pressure range	MPa {kgf/cm ² } [psi.]	0.02~0.7 {0.20~7.1} [3~102]	0.015~0.7 {0.15~7.1} [2~102]		
Proof pressure	MPa {kgf/cm ² } [psi.]	1.05 {10.7} [152]			
Operating temperature range	°C [°F]	0~60 [32~140]			
Maximum operating speed	mm/s [in./sec.]	200 [7.87] (MAX.)			
Lubrication		Prohibited			
Port size		M5×0.8	Rc1/8		Rc1/4
Stroke tolerance	mm [in.]	+1 [+0.039] 0 [0]			

Bore Size and Stroke

Operating type	Bore size	Standard strokes
Double acting type	20	10, 20
	32	10, 20, 30
	40	10, 20, 30, 40
	50	20, 30, 40, 50
Single acting push type	20	10
	32	
	40	

Remark: Non-standard strokes are collar-packed.
For delivery, consult us.

Cylinder Thrust

Select a suitable cylinder bore size considering the load and air pressure to obtain the required thrust.

Since the figures in the table are calculated values, select a bore size that results in a load ratio (load ratio = $\frac{\text{Load}}{\text{Calculated value}}$) of 70% or less.

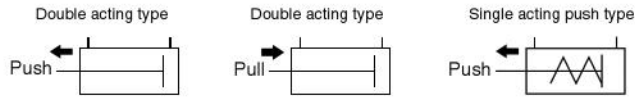

Bore size mm [in.]	Piston rod diameter mm [in.]	Operation	Pressure area mm ² [in. ²]	Air pressure MPa [psi.]							Spring return force		
				0.1 [15]	0.2 [29]	0.3 [44]	0.4 [58]	0.5 [73]	0.6 [87]	0.7 [102]	Zero stroke	Stroke end	
20 [0.787]	10 [0.394]	Double acting type	Push side	269 [0.417]	26.9 [6.05]	53.8 [12.09]	80.7 [18.14]	107.6 [24.19]	134.5 [30.24]	161.4 [36.28]	188.3 [42.33]	—	—
			Pull side	190 [0.295]	19.0 [4.27]	38.0 [8.54]	57.0 [12.81]	76.0 [17.08]	95.0 [21.36]	114.0 [25.63]	133.0 [29.90]	—	—
		Single acting push type	269 [0.417]	22.0 [4.95]	48.9 [10.99]	75.8 [17.04]	102.7 [23.09]	129.6 [29.13]	156.5 [35.18]	183.4 [41.23]	2.9 [0.65]	4.9 [1.10]	
32 [1.260]	16 [0.630]	Double acting type	Push side	684 [1.060]	68.4 [15.38]	136.8 [30.75]	205.2 [46.13]	273.6 [61.51]	342.0 [76.88]	410.4 [92.26]	478.8 [107.64]	—	—
			Pull side	483 [0.749]	48.3 [10.86]	96.6 [21.72]	144.9 [32.57]	193.2 [43.43]	241.5 [54.29]	289.8 [65.15]	338.1 [76.01]	—	—
		Single acting push type	684 [1.060]	60.5 [13.60]	128.9 [28.98]	197.3 [44.35]	265.7 [59.73]	334.1 [75.11]	402.5 [90.48]	470.9 [105.86]	4.9 [1.10]	7.9 [1.78]	
40 [1.575]	16 [0.630]	Double acting type	Push side	1100 [1.705]	110.0 [24.73]	220.0 [49.46]	330.0 [74.18]	440.0 [98.91]	550.0 [123.64]	660.0 [148.37]	770.0 [173.11]	—	—
			Pull side	903 [1.400]	90.3 [20.30]	180.6 [40.60]	270.9 [60.90]	361.2 [81.20]	451.5 [101.50]	541.8 [121.80]	632.1 [142.10]	—	—
		Single acting push type	1100 [1.705]	98.2 [22.08]	208.2 [46.80]	318.2 [71.53]	428.2 [96.26]	538.2 [120.99]	648.2 [145.72]	758.2 [170.45]	7.9 [1.78]	11.8 [2.65]	
50 [1.969]	20 [0.787]	Double acting type	Push side	1770 [2.744]	177.0 [39.79]	354.0 [79.58]	531.0 [119.37]	708.0 [159.17]	885.0 [198.96]	1062.0 [238.75]	1239.0 [278.55]	—	—
			Pull side	1450 [2.248]	145.0 [32.60]	290.0 [65.19]	435.0 [97.79]	580.0 [130.39]	725.0 [162.99]	870.0 [195.59]	1015.0 [228.19]	—	—
		Single acting push type	1770 [2.744]	145.0 [32.60]	290.0 [65.19]	435.0 [97.79]	580.0 [130.39]	725.0 [162.99]	870.0 [195.59]	1015.0 [228.19]	—	—	

N [lbf.]

Inner Construction

● Double acting type $\phi 20$, $\phi 32$, $\phi 40$, $\phi 50$ (DJDA)

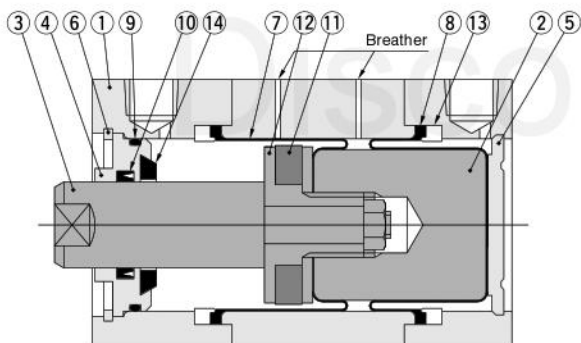

● Single acting push type $\phi 20$, $\phi 32$, $\phi 40$ (DJSA)

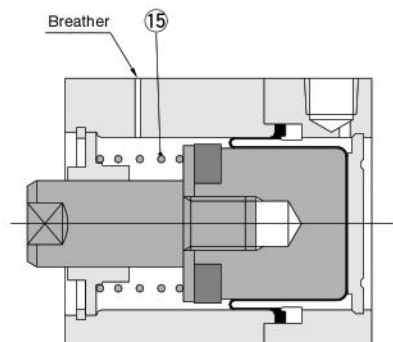

Major Parts and Materials

No.	Parts	Bore size mm [in.]	20 [0.787]	32 [1.260]	40 [1.575]	50 [1.969]
1	Cylinder body		Aluminum alloy (anodized)			
2	Piston		Aluminum alloy (anodized)			
3	Piston rod		Stainless steel	Steel		
4	Rod cover		Aluminum alloy (wear-resistant surface treatment)			
5	Head cover		Aluminum alloy (anodized)			
6	Snap ring		Steel (black oxide)			
7	BF diaphragm F		Synthetic rubber with layer cloth			
8	BF diaphragm R		Synthetic rubber with layer cloth			
9	Tube gasket		Synthetic rubber (NBR)			
10	Rod seal		Synthetic rubber (NBR)			
11	Magnet		Plastic magnet			
12	Support		Aluminum alloy (anodized)			
13	Diaphragm support		Aluminum alloy (anodized)			
14	Bumper		Synthetic rubber (urethane rubber)			
15	Spring		Piano wire			

Mounting Bracket Materials

Parts	Materials
Foot mounting bracket	Mild steel (black zinc plated)
Axial foot mounting bracket	Mild steel (black zinc plated)
Flange mounting bracket	Mild steel (black oxide)
Bracket mounting bolt	Steel (black oxide)

Air Flow Rate and Air Consumption

While the DJ cylinder double acting type's air flow rate and air consumption can be found through the following calculations, the quick reference table below provides the answers more conveniently.

Air flow rate $Q_1 = A^{\text{Note}} \times L \times \frac{60}{t} \times \frac{P+0.1013}{0.1013} \times 10^{-6}$

Air consumption $Q_2 = A^{\text{Note}} \times L \times 2 \times n \times \frac{P+0.1013}{0.1013} \times 10^{-6}$

Q₁ : Required air flow rate for cylinder ℓ /min (ANR)
 Q₂ : Air consumption of cylinder ℓ /min (ANR)
 A : Pressure area mm²
 L : Cylinder stroke mm
 t : Time required for cylinder to travel one stroke s
 n : Number of cylinder reciprocations per minute times/min
 P : Operating pressure MPa

Air flow rate $Q_1' = A'^{\text{Note}} \times L' \times \frac{60}{t} \times \frac{P'+14.696}{14.696} \times \frac{1}{1728}$

Air consumption $Q_2' = A'^{\text{Note}} \times L' \times 2 \times n \times \frac{P'+14.696}{14.696} \times \frac{1}{1728}$

Q₁' : Required air flow rate for cylinder ft³/min. (ANR)^{**}
 Q₂' : Air consumption of cylinder ft³/min. (ANR)^{**}
 A' : Pressure area in²
 L' : Cylinder stroke in.
 t : Time required for cylinder to travel one stroke sec.
 n : Number of cylinder reciprocations per minute times/min.
 P' : Operating pressure psi.

Note: For the pressure area, see the Thrust table on p.1378.

**Refer to p.42 for an explanation of ANR.

Air consumption for each 1mm [0.0394in.] stroke (DJ cylinder)

cm³ [in.³]/Reciprocation (ANR)

Bore size mm [in.]	Air pressure MPa [psi.]						
	0.1 [15]	0.2 [29]	0.3 [44]	0.4 [58]	0.5 [73]	0.6 [87]	0.7 [102]
20 [0.787]	1.07 [0.0653]	1.60 [0.0976]	2.13 [0.1300]	2.66 [0.1623]	3.19 [0.1947]	3.72 [0.2270]	4.26 [0.2600]
32 [1.260]	2.72 [0.1660]	4.07 [0.2484]	5.42 [0.3307]	6.77 [0.4131]	8.12 [0.4955]	9.47 [0.5779]	10.82 [0.6603]
40 [1.575]	4.37 [0.2667]	6.54 [0.3991]	8.72 [0.5321]	10.89 [0.6646]	13.06 [0.7970]	15.23 [0.9294]	17.40 [1.0618]
50 [1.969]	7.03 [0.4290]	10.53 [0.6426]	14.02 [0.8556]	17.52 [1.0691]	21.01 [1.2821]	24.51 [1.4957]	28.00 [1.7087]

The figures in the table are to calculate the air flow rate and air consumption when a DJ cylinder (double acting type) makes one reciprocation with stroke of 1mm [0.0394in.].

The air flow rate and air consumption actually required are found by the following calculations.

● Finding the air flow rate (for selecting F.R.L., valves, etc.)

Example: When operating a DJ cylinder (double acting type) with bore size of 40mm [1.575in.] at speed of 200mm/s [7.9in./sec.] under air pressure 0.5MPa [73psi.]

$$13.06 \times \frac{1}{2} \times 200 \times 10^{-3} = 1.306 \text{ ℓ /s [0.0461ft}^3\text{/sec.]} \text{ (ANR)}$$

(At this time, the air flow rate per minute is $13.06 \times \frac{1}{2} \times 200 \times 60 \times 10^{-3} = 78.36 \text{ ℓ /min [2.766ft}^3\text{/min.]} \text{ (ANR).}$)

● Finding the air consumption

Example 1. When operating a DJ cylinder (double acting type) with bore size of 40mm [1.575in.] and stroke of 40mm [1.575in.] under air pressure 0.5MPa [73psi.], for one reciprocation per minute

$$13.06 \times 40 \times 10^{-3} = 0.5224 \text{ ℓ [0.0184ft}^3\text{]/Reciprocation (ANR)}$$

Example 2. When operating a DJ cylinder (double acting type) with bore size of 40mm [1.575in.] and stroke of 40mm [1.575in.] under air pressure 0.5MPa [73psi.], for 10 reciprocations per minute

$$13.06 \times 40 \times 10 \times 10^{-3} = 5.224 \text{ ℓ /min [0.184ft}^3\text{/min.]} \text{ (ANR)}$$

Order Code

DJ **20×10** - -

DJ cylinder

Operating type^{Note1}
DA : Double acting type
SA : Single acting push type

Bore size × stroke^{Note2}

Mounting type^{Note3}
Blank : Basic type
1 : Foot mounting type
2 : Axial foot mounting type
3 : Rod side flange mounting type
5 : Head side flange mounting type

Sensor switch
Blank : Without sensor switch
ZE135 : 2-lead wire Solid state type With indicator lamp Horizontal lead wire DC10~28V
ZE235 : 2-lead wire Solid state type With indicator lamp Vertical lead wire^{Note5} DC10~28V
ZE155 : 3-lead wire Solid state type With indicator lamp Horizontal lead wire DC4.5~28V
ZE255 : 3-lead wire Solid state type With indicator lamp Vertical lead wire^{Note5} DC4.5~28V
ZE101 : 2-lead wire Reed switch type^{Note4} Without indicator lamp Horizontal lead wire DC5~28V, AC85~115V
ZE201 : 2-lead wire Reed switch type^{Note4} Without indicator lamp Vertical lead wire^{Note5} DC5~28V, AC85~115V
ZE102 : 2-lead wire Reed switch type^{Note4} With indicator lamp Horizontal lead wire DC10~28V, AC85~115V
ZE202 : 2-lead wire Reed switch type^{Note4} With indicator lamp Vertical lead wire^{Note5} DC10~28V, AC85~115V

Lead wire length
A : 1000mm [39in.]
B : 3000mm [118in.]

Number of sensor switches
1 : With one sensor switch
2 : With two sensor switches
:
n : With n sensor switches

● For details of sensor switches, see p.1398.

- Notes: 1. Single acting push type is available in $\phi 20$ [0.787in.] to $\phi 40$ [1.575in.] only.
 2. For the bore size and stroke, see p.1377.
 3. The $\phi 20$ [0.787in.] is available in the basic type only.
 4. When using the reed switch type sensor switch, maintain a minimum speed of 30mm/s [1.2in./sec.] or larger. A speed of less than 30mm/s [1.2in./sec.] could cause the contact reed part to deposit, resulting in erratic operations. For balancer or tension control operations, the solid state type is recommended, instead.
 5. In the vertical lead wire type, the lead wire protrudes at right angles to the sensor switch.

● Mounting bracket only

- **DJDA**

Mounting bracket
1 : Foot mounting type
2 : Axial foot mounting type
3 : Flange mounting type (Rod/head side in common)

DJ Cylinder

Bore size
32 : For $\phi 32$ [1.260in.]
40 : For $\phi 40$ [1.575in.]
50 : For $\phi 50$ [1.969in.]

Mounting bracket content		pcs.
Model	Contents	
1 - DJDA <input type="checkbox"/>	Bracket: 2	Mounting bolt: 4
2 - DJDA <input type="checkbox"/>	Bracket: 2	Mounting bolt: 4
3 - DJDA <input type="checkbox"/>	Bracket: 1	Mounting bolt: 4

Dimensions of Double Acting Type (mm)

● Basic type DJDA 20× [Stroke] (φ20)

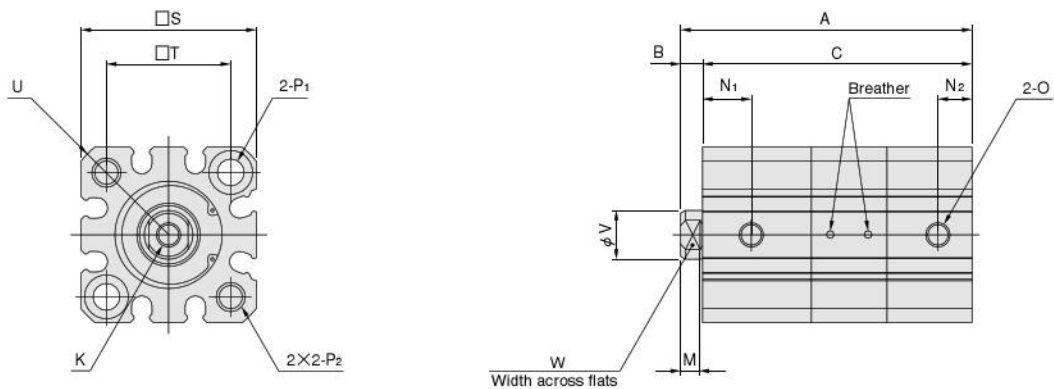

Remark: Basic type only for φ20.

● Basic type DJDA [Bore size] × [Stroke] (φ32~φ50)

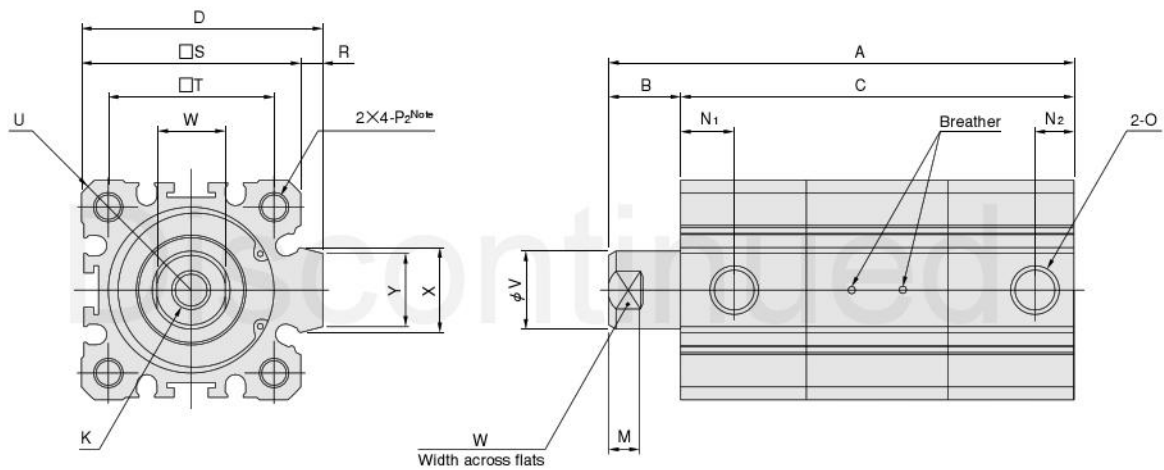

Note: Through bolts cannot be used.

Code Stroke	A					B	C					D
	10	20	30	40	50		10	20	30	40	50	
20 [0.787]	58	68	—	—	—	4.5	53.5	63.5	—	—	—	—
32 [1.260]	96	96	106	—	—	15	81	81	91	—	—	49.5
40 [1.575]	114	114	124	134	—	17	97	97	107	117	—	57
50 [1.969]	—	136	136	146	156	18	—	118	118	128	138	71

Code Bore mm [in.]	K		M	N ₁	N ₂	O	P ₁
	Depth						
20 [0.787]	M5×0.8	Depth 7	4	10	5	M5×0.8	φ 5.5 Through hole, φ 9 Counterbore Depth 5.4 (Both sides)
32 [1.260]	M8×1.25	Depth 13	6.5	11	7.5	Rc 1/8	—
40 [1.575]	M8×1.25	Depth 13	6.5	11.5	11.5	Rc 1/8	—
50 [1.969]	M10×1.5	Depth 15	7	12	12	Rc 1/4	—

Code Bore mm [in.]	P ₂		R	S	T	U	V	W	X	Y
	Depth									
20 [0.787]	M6×1	Depth 12	—	36	25.5	R23.5	10	8	—	—
32 [1.260]	M6×1	Depth 12	4.5	45	34	R30	16	14	17.4	15
40 [1.575]	M6×1	Depth 12	5	52	40	R34.5	16	14	20.5	17.5
50 [1.969]	M8×1.25	Depth 16	7	64	50	R42.5	20	17	21.6	19

Dimensions of Double Acting Type (mm)

●Foot mounting type DJDA [Bore size] × [Stroke] -1

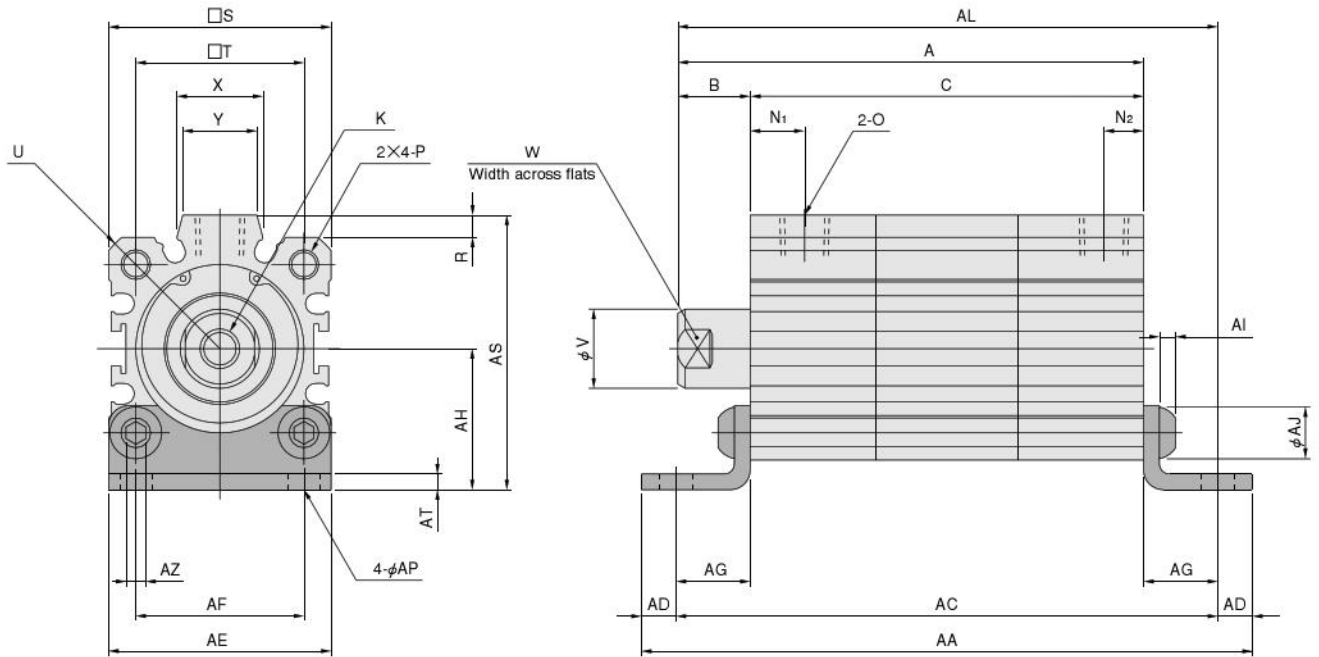

Discontinued

Code Bore mm [in.] Stroke	A					B	C					K	N ₁	N ₂	O
	10	20	30	40	50		10	20	30	40	50				
32 [1.260]	96	96	106	—	—	15	81	81	91	—	—	M8×1.25 Depth 13	11	7.5	Rc 1/8
40 [1.575]	114	114	124	134	—	17	97	97	107	117	—	M8×1.25 Depth 13	11.5	11.5	Rc 1/8
50 [1.969]	—	136	136	146	156	18	—	118	118	128	138	M10×1.5 Depth 15	12	12	Rc 1/4

Code Bore mm [in.] Stroke	P		R	S	T	U	V	W	X	Y	AA				
	M	Depth									10	20	30	40	50
32 [1.260]	M6×1	Depth 12	4.5	45	34	R30	16	14	17.4	15	125	125	135	—	—
40 [1.575]	M6×1	Depth 12	5	52	40	R34.5	16	14	20.5	17.5	141	141	151	161	—
50 [1.969]	M8×1.25	Depth 16	7	64	50	R42.5	20	17	21.6	19	—	172	172	182	192

Code Bore mm [in.] Stroke	AC					AD	AE	AF	AG	AH	AI	AJ	AL					AP	AS	AT	AZ
	10	20	30	40	50								10	20	30	40	50				
32 [1.260]	111	111	121	—	—	7	45	34	15	28.5	4	10.5	111	111	121	—	—	6.6	55.5	3.2	4
40 [1.575]	127	127	137	147	—	7	53	40	15	32.5	4	10.5	129	129	139	149	—	6.6	63.5	3.2	4
50 [1.969]	—	154	154	164	174	9	64	50	18	38	5	14	—	154	154	164	174	9	77	3.2	5

Dimensions of Double Acting Type (mm)

● Axial foot mounting type DJDA × -2

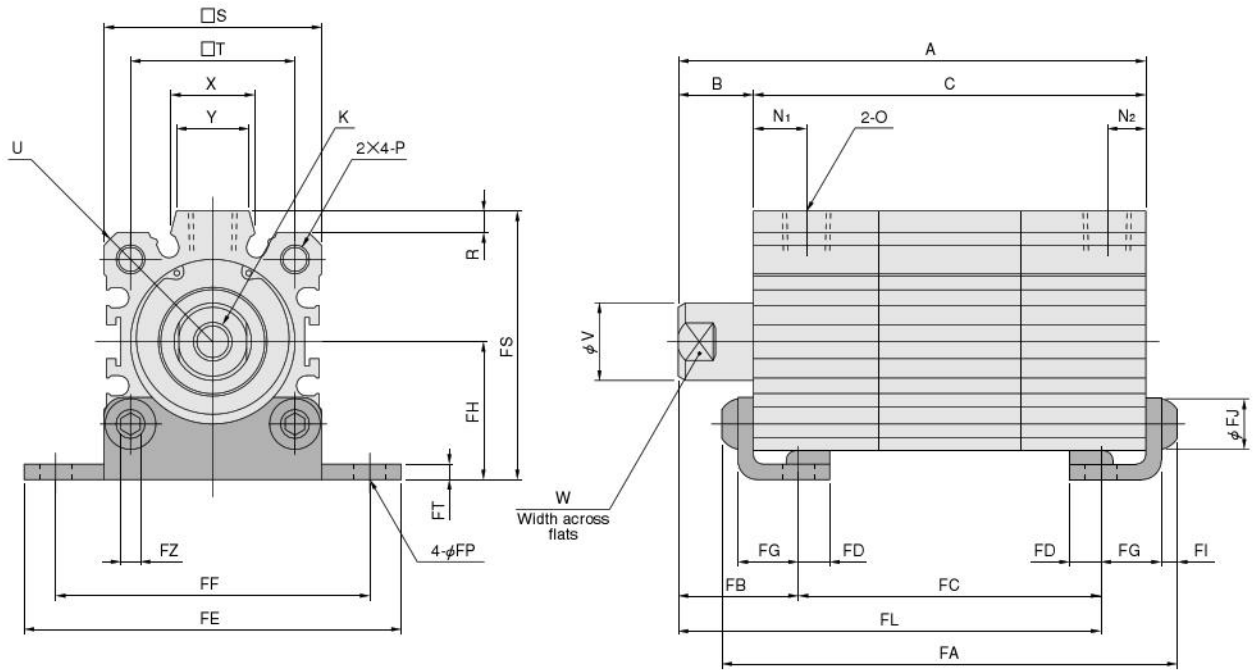

Discontinued

Code Bore mm [in.] Stroke	A					B	C					K	N ₁	N ₂	O
	10	20	30	40	50		10	20	30	40	50				
32 [1.260]	96	96	106	—	—	15	81	81	91	—	—	M8×1.25 Depth 13	11	7.5	Rc 1/8
40 [1.575]	114	114	124	134	—	17	97	97	107	117	—	M8×1.25 Depth 13	11.5	11.5	Rc 1/8
50 [1.969]	—	136	136	146	156	18	—	118	118	128	138	M10×1.5 Depth 15	12	12	Rc 1/4

Code Bore mm [in.] Stroke	P	R	S	T	U	V	W	X	Y	FA					FB
										10	20	30	40	50	
32 [1.260]	M6×1 Depth 12	4.5	45	34	R30	16	14	17.4	15	95.4	95.4	105.4	—	—	24.3
40 [1.575]	M6×1 Depth 12	5	52	40	R34.5	16	14	20.5	17.5	111.4	111.4	121.4	131.4	—	26.3
50 [1.969]	M8×1.25 Depth 16	7	64	50	R42.5	20	17	21.6	19	—	134.4	134.4	144.4	154.4	28.8

Code Bore mm [in.] Stroke	FC					FD	FE	FF	FG	FH	FI	FJ	FL					FP	FS	FT	FZ
	10	20	30	40	50								10	20	30	40	50				
32 [1.260]	62.4	62.4	72.4	—	—	6.5	78	65	12.5	28.5	4	10.5	86.7	86.7	96.7	—	—	6.6	55.5	3.2	4
40 [1.575]	78.4	78.4	88.4	98.4	—	6.5	87	73	12.5	32.5	4	10.5	104.7	104.7	114.7	124.7	—	6.6	63.5	3.2	4
50 [1.969]	—	96.4	96.4	106.4	116.4	8	103	87	14	38	5	14	—	125.2	125.2	135.2	145.2	9	77	3.2	5

Dimensions of Double Acting Type (mm)

●Head side flange mounting type DJDA [Bore size] × [Stroke] -5

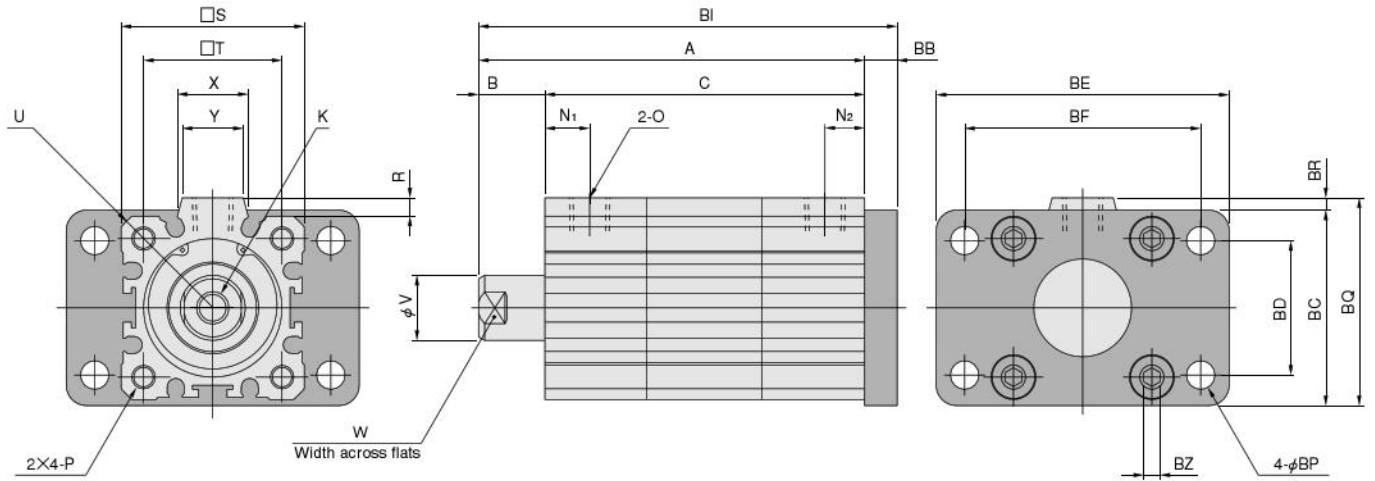

Discontinued

Code Bore mm [in.]	A					B	C					K	N ₁	N ₂	O
	10	20	30	40	50		10	20	30	40	50				
32 [1.260]	96	96	106	—	—	15	81	81	91	—	—	M8×1.25 Depth 13	11	7.5	Rc 1/8
40 [1.575]	114	114	124	134	—	17	97	97	107	117	—	M8×1.25 Depth 13	11.5	11.5	Rc 1/8
50 [1.969]	—	136	136	146	156	18	—	118	118	128	138	M10×1.5 Depth 15	12	12	Rc 1/4

Code Bore mm [in.]	P		R	S	T	U	V	W	X	Y	BB
32 [1.260]	M6×1	Depth 12	4.5	45	34	R30	16	14	17.4	15	8
40 [1.575]	M6×1	Depth 12	5	52	40	R34.5	16	14	20.5	17.5	10
50 [1.969]	M8×1.25	Depth 16	7	64	50	R42.5	20	17	21.6	19	10

Code Bore mm [in.]	BC	BD	BE	BF	BI					BP	BQ	BR	BZ
					10	20	30	40	50				
32 [1.260]	48	33	72	58	104	104	114	—	—	7	51	3	4
40 [1.575]	56	36	84	70	124	124	134	144	—	7	59	3	4
50 [1.969]	70	47	104	86	—	146	146	156	166	9	74	4	5

Dimensions of Single Acting Push Type (mm)

●Basic type DJSA 20×10 (φ20)

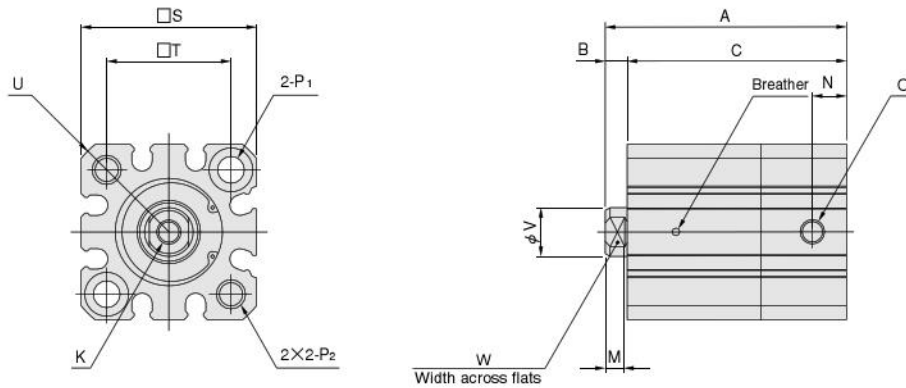

●Basic type DJSA Bore size ×10 (φ32~φ40)

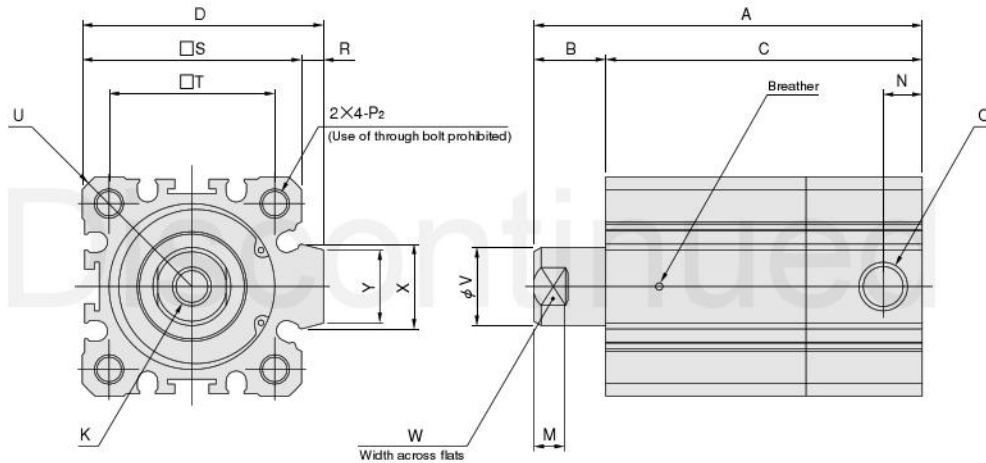

Code Bore mm [in.]	A	B	C	D	K	M	N	O
20 [0.787]	50.5	4.5	46	—	M5×0.8 Depth 10	4	5	M5×0.8
32 [1.260]	74	15	59	49.5	M8×1.25 Depth 13	6.5	7.5	Rc 1/8
40 [1.575]	88	17	71	57	M8×1.25 Depth 13	6.5	11.5	Rc 1/8

Code Bore mm [in.]	P ₂	R	S	T	U	V	W	X	Y
20 [0.787]	M6×1 Depth 12	—	36	25.5	R23.5	10	8	—	—
32 [1.260]	M6×1 Depth 12	4.5	45	34	R30	16	14	17.4	15
40 [1.575]	M6×1 Depth 12	5	52	40	R34.5	16	14	20.5	17.5

Code Bore mm [in.]	P ₁
20 [0.787]	φ 5.5 Through hole, φ 9 Counterbore Depth 5.4 (Both sides)

Dimensions of Single Acting Push Type (mm)

●Foot mounting type DJSA [Bore size] × [Stroke] -1

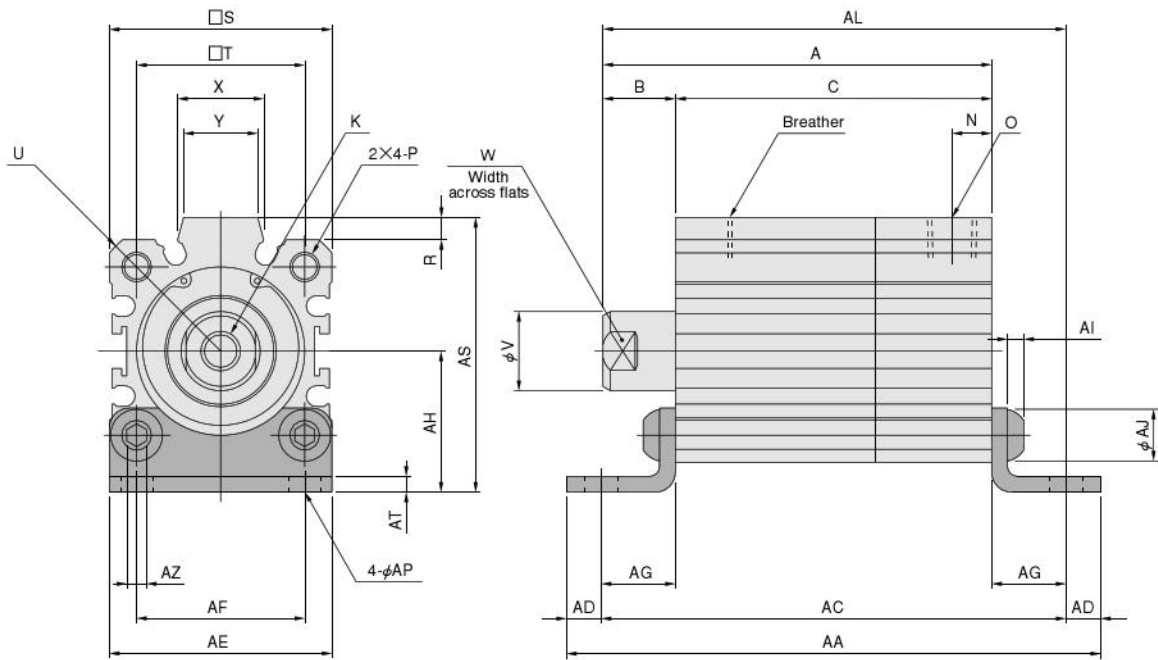

Discontinued

Code Bore mm [in.]	A	B	C	K	N	O	P
32 [1.260]	74	15	59	M8×1.25 Depth 13	7.5	Rc 1/8	M6×1 Depth 12
40 [1.575]	88	17	71	M8×1.25 Depth 13	11.5	Rc 1/8	M6×1 Depth 12

Code Bore mm [in.]	R	S	T	U	V	W	X	Y	AA	AC	AD
32 [1.260]	4.5	45	34	R30	16	14	17.4	15	103	89	7
40 [1.575]	5	52	40	R34.5	16	14	20.5	17.5	115	101	7

Code Bore mm [in.]	AE	AF	AG	AH	AI	AJ	AL	AP	AS	AT	AZ
32 [1.260]	45	34	15	28.5	4	10.5	89	6.6	55.5	3.2	4
40 [1.575]	53	40	15	32.5	4	10.5	103	6.6	63.5	3.2	4

Dimensions of Single Acting Push Type (mm)

● Axial foot mounting type DJSA × -2

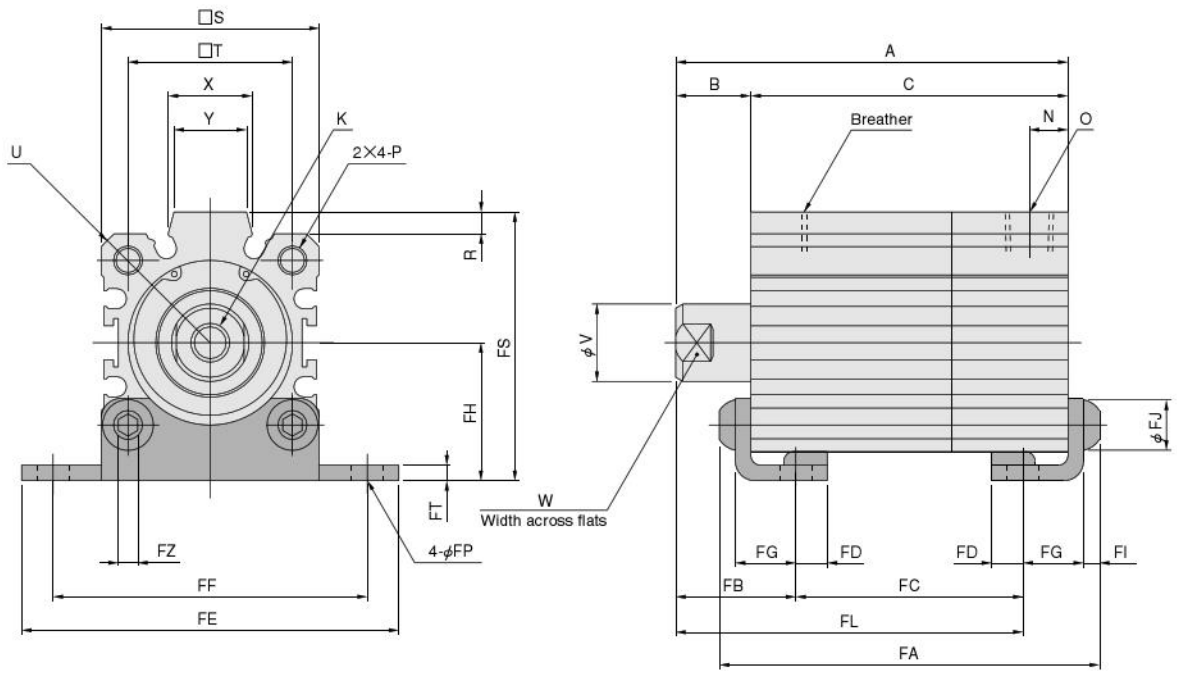

Discontinued

Code Bore mm [in.]	A	B	C	K	N	O	P
32 [1.260]	74	15	59	M8×1.25 Depth 13	7.5	Rc 1/8	M6×1 Depth 12
40 [1.575]	88	17	71	M8×1.25 Depth 13	11.5	Rc 1/8	M6×1 Depth 12

Code Bore mm [in.]	R	S	T	U	V	W	X	Y	FA	FB	FC
32 [1.260]	4.5	45	34	R30	16	14	17.4	15	73.4	24.3	40.4
40 [1.575]	5	52	40	R34.5	16	14	20.5	17.5	85.4	26.3	52.4

Code Bore mm [in.]	FD	FE	FF	FG	FH	FI	FJ	FL	FP	FS	FT	FZ
32 [1.260]	6.5	78	65	12.5	28.5	4	10.5	64.7	6.6	55.5	3.2	4
40 [1.575]	6.5	87	73	12.5	32.5	4	10.5	78.7	6.6	63.5	3.2	4

Dimensions of Single Acting Push Type (mm)

●Rod side flange mounting type DJSA [Bore size] × [Stroke] -3

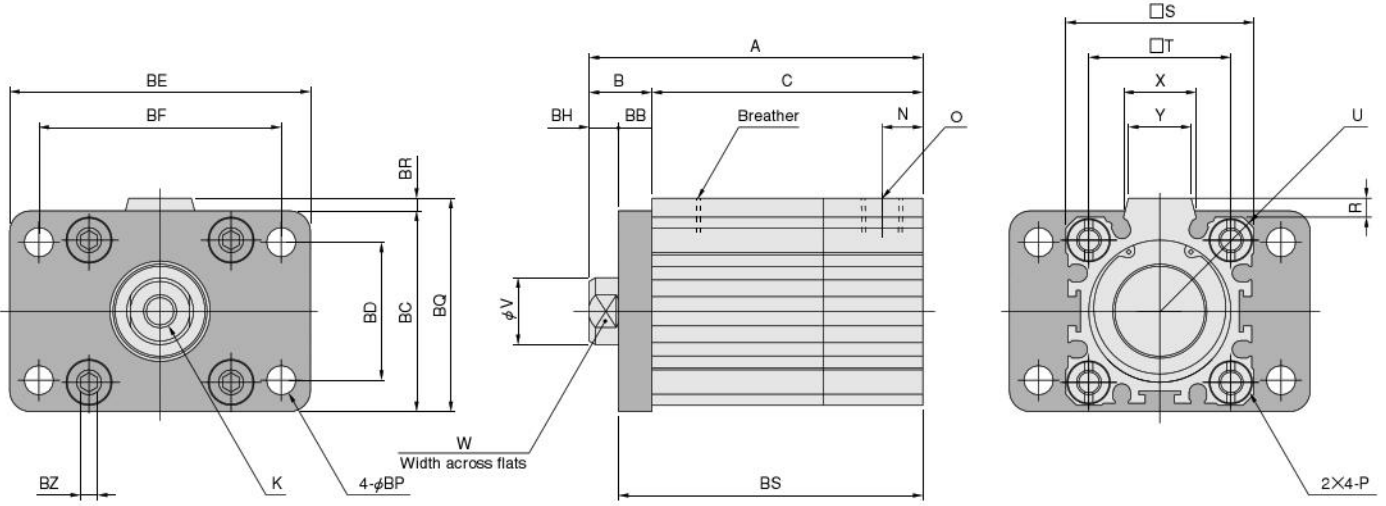

Discontinued

Code Bore mm [in.]	A	B	C	K	N	O	P
32 [1.260]	74	15	59	M8×1.25 Depth 13	7.5	Rc 1/8	M6×1 Depth 12
40 [1.575]	88	17	71	M8×1.25 Depth 13	11.5	Rc 1/8	M6×1 Depth 12

Code Bore mm [in.]	R	S	T	U	V	W	X	Y	BB	BC	BD
32 [1.260]	4.5	45	34	R30	16	14	17.4	15	8	48	33
40 [1.575]	5	52	40	R34.5	16	14	20.5	17.5	10	56	36

Code Bore mm [in.]	BE	BF	BH	BP	BQ	BR	BS	BZ
32 [1.260]	72	58	7	7	51	3	67	4
40 [1.575]	84	70	7	7	59	3	81	4

Dimensions of Single Acting Push Type (mm)

●Head side flange mounting type DJSA [Bore size] × [Stroke] -5

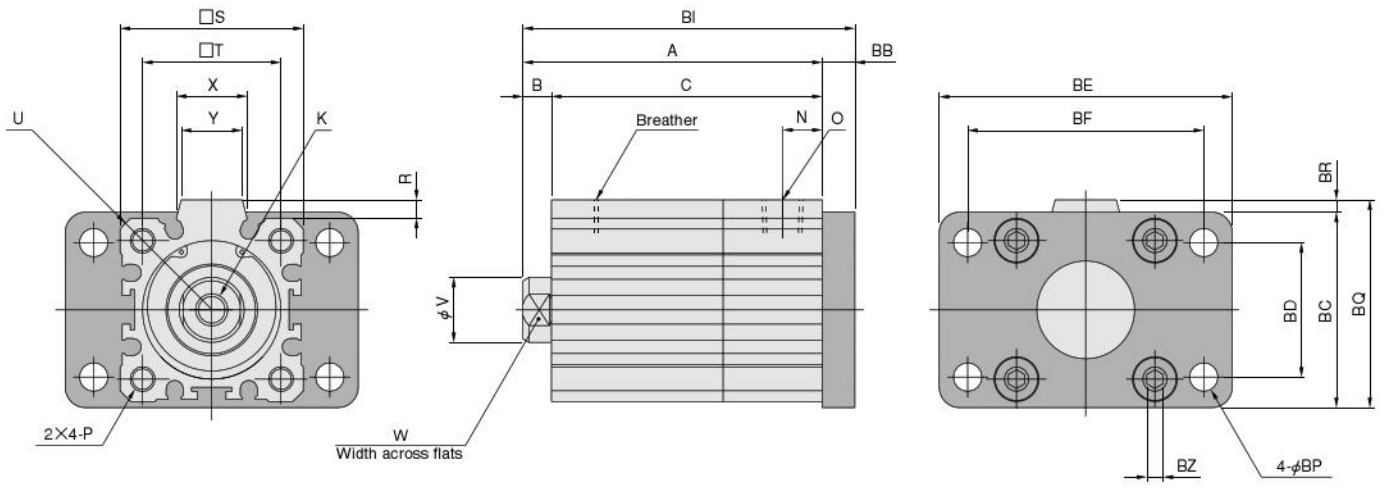

Discontinued

Code Bore mm [in.]	A	B	C	K	N	O	P
32 [1.260]	74	15	59	M8×1.25 Depth 13	7.5	Rc 1/8	M6×1 Depth 12
40 [1.575]	88	17	71	M8×1.25 Depth 13	11.5	Rc 1/8	M6×1 Depth 12

Code Bore mm [in.]	R	S	T	U	V	W	X	Y	BB	BC	BD
32 [1.260]	4.5	45	34	R30	16	14	17.4	15	8	48	33
40 [1.575]	5	52	40	R34.5	16	14	20.5	17.5	10	56	36

Code Bore mm [in.]	BE	BF	BI	BP	BQ	BR	BZ
32 [1.260]	72	58	82	7	51	3	4
40 [1.575]	84	70	98	7	59	3	4

DF CYLINDERS

Non-rotating Single Acting Push Type



Features

- A thin and lightweight cylinder for precision control.
- Air leaks almost never occur with the diaphragm's perfect seal.
- With no sliding portion open to the air, solid particles are eliminated.

Symbol

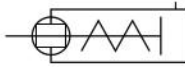

Order Code

DFSAL

DF Cylinder



Bore size × Stroke

Specifications

Item	Bore size mm [in.]	Bore size			
		12 [0.472]	20 [0.787]	30 [1.181]	40 [1.575]
Operating type		Non-rotating single acting push type			
Media		Air			
Operating pressure range	MPa {kgf/cm ² } [psi.]	0.07~0.5 {0.7~5.1} [10~73]		0.02~0.5 {0.2~5.1} [3~73]	
Proof pressure	MPa {kgf/cm ² } [psi.]	0.75 {7.1} [109]			
Operating temperature range	°C [°F]	0~60 [32~140]			
Maximum operating speed	mm/s [in./sec.]	200 [7.87] (MAX.)			
Lubrication		Prohibited			
Port size		M5×0.8			
Stroke	mm [in.]	3 [0.118]		5 [0.197]	
Stroke tolerance	mm [in.]	±0.6 [±0.024]			
Mass	g [oz.]	35 [1.23]	65 [2.29]	110 [3.88]	160 [5.64]

Cylinder Thrust

Select a suitable cylinder bore size considering the load and air pressure to obtain the required thrust.

Since the figures in the table are calculated values, select a bore size that results in a load ratio (load ratio = $\frac{\text{Load}}{\text{Calculated value}}$) of 70% or less.

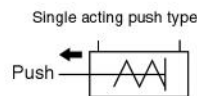

Bore size mm [in.]	Piston rod diameter mm [in.]	Operation	Pressure area mm ² [in. ²]	Air pressure MPa [psi.]					Spring return force	
				0.1 [15]	0.2 [29]	0.3 [44]	0.4 [58]	0.5 [73]	Zero stroke	End of stroke
				N [lbf.]						
12 [0.472]	5 [0.197]	Single acting push type	80 [0.124]	7.4 [1.66]	15.4 [3.46]	23.4 [5.26]	31.4 [7.06]	39.4 [8.86]	0.39 [0.0877]	0.59 [0.1326]
20 [0.787]	10 [0.394]	Single acting push type	250 [0.388]	23.2 [5.22]	48.2 [10.84]	73.2 [16.46]	98.2 [22.08]	123.2 [27.70]	0.98 [0.2203]	1.76 [0.3956]
30 [1.181]	16 [0.630]	Single acting push type	570 [0.884]	53.2 [11.96]	110.2 [24.77]	167.2 [37.59]	224.2 [50.40]	281.2 [63.21]	1.77 [0.3979]	3.77 [0.8475]
40 [1.575]	21 [0.827]	Single acting push type	1040 [1.612]	97.6 [21.94]	201.6 [45.32]	305.6 [68.70]	409.6 [92.08]	513.6 [115.46]	4.41 [0.9914]	6.37 [1.4320]

Air Flow Rate and Air Consumption

The DF cylinder's air flow rate and air consumption can be found through the following calculations.

$$\text{Air flow rate } Q_1 = A^{\text{Note}} \times L \times \frac{60}{t} \times \frac{P+0.1013}{0.1013} \times 10^{-6}$$

$$\text{Air consumption } Q_2 = A^{\text{Note}} \times L \times n \times \frac{P+0.1013}{0.1013} \times 10^{-6}$$

Q_1 : Required air flow rate for cylinder ℓ /min (ANR)
 Q_2 : Air consumption of cylinder ℓ /min (ANR)
 A : Pressure area mm²
 L : Cylinder stroke mm
 t : Time required for cylinder to travel one stroke s
 n : Number of cylinder reciprocations per minute times/min
 P : Operating pressure MPa

$$\text{Air flow rate } Q_1' = A'^{\text{Note}} \times L' \times \frac{60}{t} \times \frac{P'+14.696}{14.696} \times \frac{1}{1728}$$

$$\text{Air consumption } Q_2' = A'^{\text{Note}} \times L' \times n \times \frac{P'+14.696}{14.696} \times \frac{1}{1728}$$

Q_1' : Required air flow rate for cylinder ft³/min. (ANR)^{**}
 Q_2' : Air consumption of cylinder ft³/min. (ANR)^{**}
 A' : Pressure area in²
 L' : Cylinder stroke in.
 t : Time required for cylinder to travel one stroke sec.
 n : Number of cylinder reciprocations per minute times/min.
 P' : Operating pressure psi.

Note: For the pressure area, see the Thrust table on p.1391.

**Refer to p.42 for an explanation of ANR.

Inner Construction

● φ 12, φ 20

● φ 30, φ 40

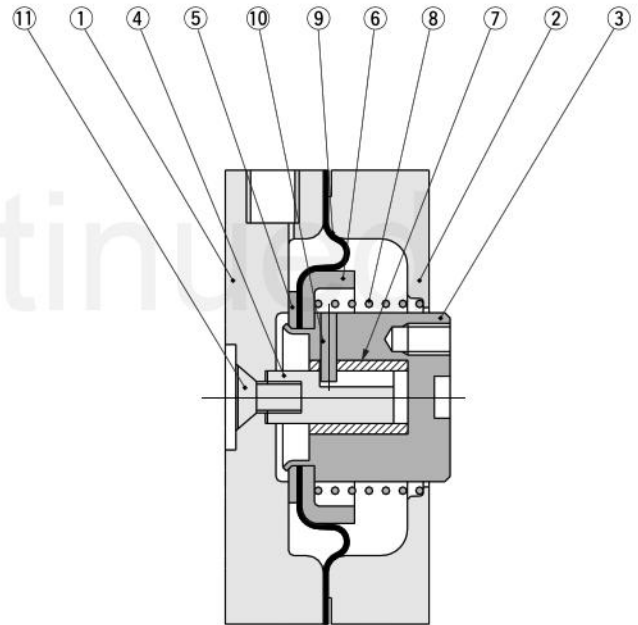
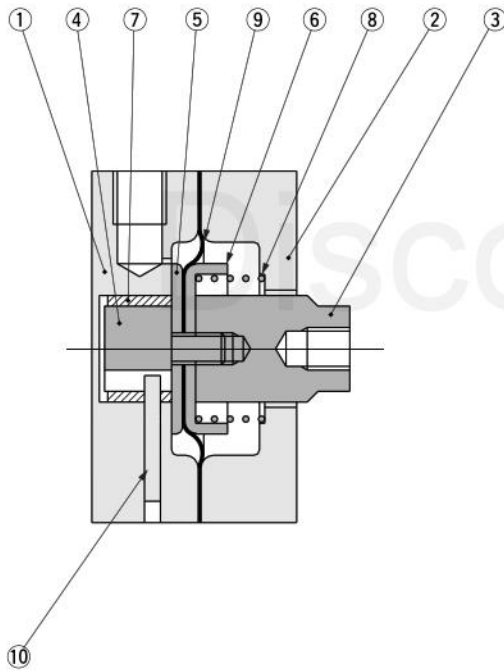

Major Parts and Materials

No.	Parts	Bore mm [in.]	12 [0.472]	20 [0.787]	30 [1.181]	40 [1.575]
①	Body A			Aluminum alloy (anodized)		
②	Body B			Aluminum alloy (anodized)		
③	Rod			Stainless steel		
④	Guide rod			Stainless steel		
⑤	Retainer			Rolled steel plate (uni chrome plated)		
⑥	Piston			Rolled steel plate (uni chrome plated)		
⑦	Bushing			Plastic		
⑧	Spring			Stainless steel wire for spring		
⑨	Diaphragm			Nitrile rubber with layer cloth		
⑩	Needle roller			Steel		
⑪	Cross recessed countersunk head screw			Stainless steel		

Dimensions of DF Cylinder (mm)

DFSAL Bore size × Stroke

CAD DFSAL Bore size

● $\phi 12, \phi 20$

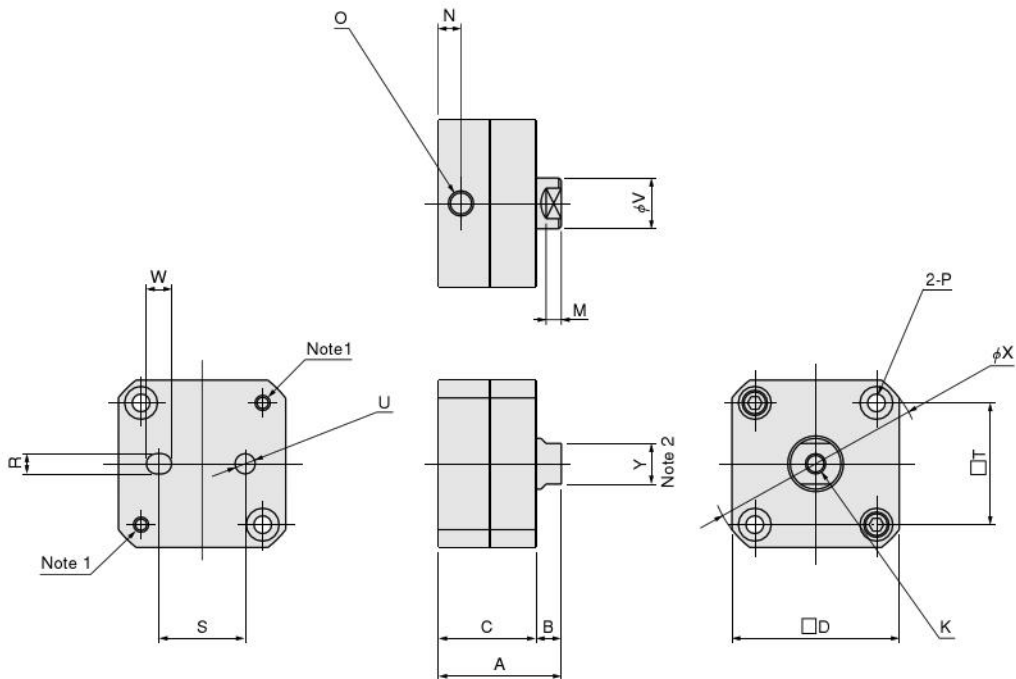

Notes: 1. Do not use these threads for mounting a cylinder.
2. Angle of the width across flats to the cylinder center line are not fixed due to the construction.

Bore mm [in.]	Code	A	B	C	D	K	M	N	O	P	R	S	T	U	V	W	X	Y
12 [0.472]		24.3	5	19.3	25	M3×0.5 Depth 3	3	4.5	M5×0.8	$\phi 3.5$ (Thru hole) Counterbore $\phi 6.5$ Depth 3.5 (Both sides)	$4^{+0.012}_0$ Depth 4	15	17	$\phi 4H7^{(+0.012)}_0$ Depth 4	5	5	33	4
20 [0.787]		24.3	5	19.3	33	M4×0.7 Depth 4	3	4.5	M5×0.8	$\phi 3.5$ (Thru hole) Counterbore $\phi 6.5$ Depth 3.5 (Both sides)	$4^{+0.012}_0$ Depth 4	17	24	$\phi 4H7^{(+0.012)}_0$ Depth 4	10	5	42	8

● $\phi 30, \phi 40$

CAD DFSAL Bore size

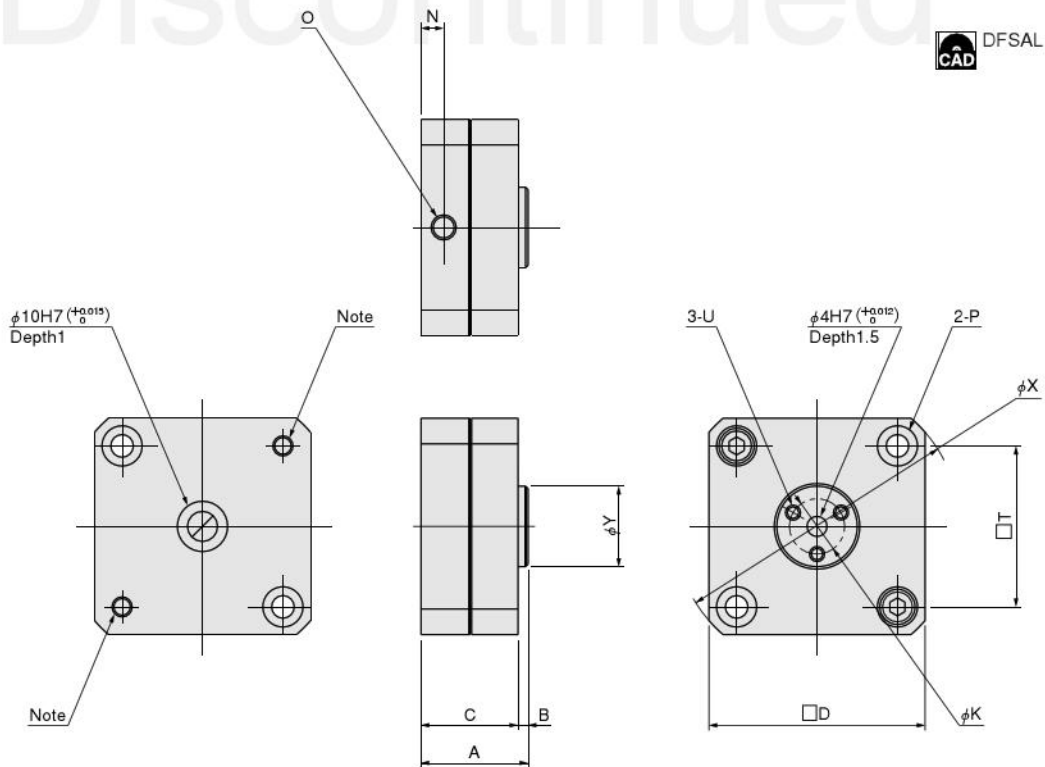

Note: Do not use these threads for mounting a cylinder.

Bore mm [in.]	Code	A	B	C	D	K	N	O	P	T	U	X	Y
30 [1.181]		21.3	2	19.3	43	11	4.5	M5×0.8	$\phi 4.5$ (Through hole) Counterbore $\phi 8$ Depth 5.5 (Both sides)	32	M3×0.5 Depth 4	57	16
40 [1.575]		21.3	2	19.3	53	16	4.5	M5×0.8	$\phi 5.5$ (Through hole) Counterbore $\phi 9.5$ Depth 5.5 (Both sides)	40	M3×0.5 Depth 4	68	21

SENSOR SWITCHES

Solid State Type, Reed Switch Type

Symbols

● Double acting type ● Single acting push type



Order Code

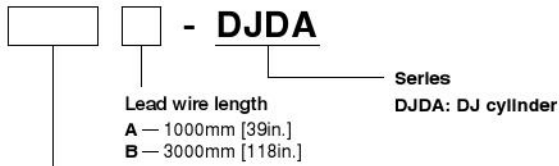

Sensor switch

ZE135	— Solid state type	With indicator lamp	DC10~28V	Horizontal lead wire
ZE235	— Solid state type	With indicator lamp	DC10~28V	Vertical lead wire
ZE155	— Solid state type	With indicator lamp	DC4.5~28V	Horizontal lead wire
ZE255	— Solid state type	With indicator lamp	DC4.5~28V	Vertical lead wire
ZE101	— Reed switch type	Without indicator lamp	DC5~28V	Horizontal lead wire
			AC85~115V	
ZE201	— Reed switch type	Without indicator lamp	DC5~28V	Vertical lead wire
			AC85~115V	
ZE102	— Reed switch type	With indicator lamp	DC10~28V	Horizontal lead wire
			AC85~115V	
ZE202	— Reed switch type	With indicator lamp	DC10~28V	Vertical lead wire
			AC85~115V	

● For details of sensor switches, see p.1398.

Minimum Cylinder Strokes when Using Sensor Switches

		mm [in.]			
Type	Mounting Bore size	2 pcs. mounting		1 pc. mounting	
		1-surface mounting			
		1-groove mounting	2-groove mounting		
Solid state type	20~50 [0.787~1.969]	20 ^{Note}	10	10	10
Reed switch type	20~50 [0.787~1.969]	20 ^{Note}	10	10	10

Note: The figures in the above table assume that the opposite end surfaces of the lead wires are mounted facing each other around the cylinder center.

Moving Sensor Switch

- Loosening the mounting screw allows the sensor switch to be moved along the switch mounting groove on the cylinder body.
- Tighten the mounting screw with a tightening torque of 0.1~0.2N·m {1~2kgf·cm} [0.9~1.8in·lbf]. Overtightening could damage the sensor switch and actuator.

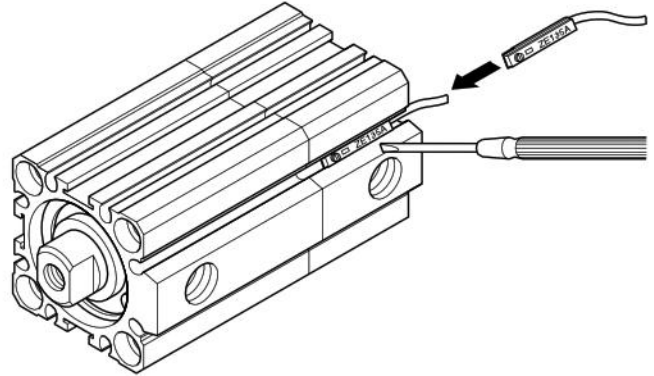

Sensor Switch Operating Range, Response Differential, and Maximum Sensing Location

● Operating range: ℓ

The distance the piston travels in one direction, while the switch is in the ON position.

● Response differential: C

The distance between the point where the piston turns the switch ON and the point where the switch is turned OFF as the piston travels in the opposite direction.

● Solid state type

		mm [in.]			
Item	Bore size	20 [0.787]	32 [1.260]	40 [1.575]	50 [1.969]
Operating range: ℓ		2.0~6.0 [0.079~0.236]	3.0~7.0 [0.118~0.276]	3.0~7.0 [0.118~0.276]	4.0~8.0 [0.157~0.315]
Response differential: C		1.0 [0.039] or less			
Maximum sensing location		6 [0.236]			

Note: These are values measured from the other end side of the lead wire.
The above table shows reference values.

● Reed switch type

		mm [in.]			
Item	Bore size	20 [0.787]	32 [1.260]	40 [1.575]	50 [1.969]
Operating range: ℓ		8.0~12.0 [0.315~0.472]	10.0~14.0 [0.394~0.551]	11.0~15.0 [0.433~0.591]	12.0~16.0 [0.472~0.630]
Response differential: C		1.5 [0.059] or less			
Maximum sensing location		10 [0.394]			

Note: These are values measured from the other end side of the lead wire.
The above table shows reference values.

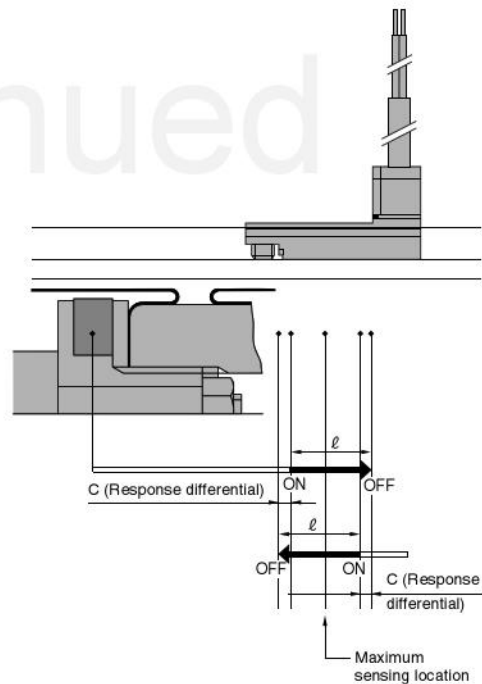

Mounting Location of End of Stroke Detection Sensor Switch



Standard cylinder: Double acting type and single acting push type

● Solid state type: Double acting type

mm [in.]

Stroke Code	Bore size 20 [0.787]		32 [1.260]		40 [1.575]		50 [1.969]	
	10~20	10	20~30	10	20~40	20	30~50	
X	9 [0.354]	21.5 [0.846]	11.5 [0.453]	24.3 [0.957]	14.3 [0.563]	25 [0.984]	15 [0.591]	
Y	22.5 [0.886]	37.5 [1.476]	50.7 [1.996]	61 [2.402]				
Z ^{Note}	19 [0.748]	34 [1.339]	47.2 [1.858]	57.5 [2.264]				

Note: The values show the horizontal lead wire type.
The vertical lead wire type is 0.5mm [0.020in.] longer.

● Solid state type: Single acting push type

mm [in.]

Code	Bore size 20 [0.787]		32 [1.260]		40 [1.575]	
	8.5	11.5	18	27	31	36
X	8.5 [0.335]	11.5 [0.453]	18 [0.709]	27 [1.063]	31 [1.220]	36 [1.417]
Y	15.5 [0.610]	25.5 [1.004]	31 [1.220]	41 [1.614]	46 [1.811]	51 [2.008]
Z ^{Note}	12 [0.472]	22 [0.866]	27.5 [1.083]	37.5 [1.476]	42.5 [1.673]	47.5 [1.870]

Note: The values show the horizontal lead wire type.
The vertical lead wire type is 0.5mm [0.020in.] longer.

● Reed switch type: Double acting type

mm [in.]

Stroke Code	Bore size 20 [0.787]		32 [1.260]		40 [1.575]		50 [1.969]	
	10~20	10	20~30	10	20~40	20	30~50	
X	5 [0.197]	17.5 [0.689]	7.5 [0.295]	20.3 [0.799]	10.3 [0.406]	21 [0.827]	11 [0.433]	
Y	18.5 [0.728]	33.5 [1.319]	46.7 [1.839]	57 [2.244]				
Z ^{Note}	16 [0.630]	31 [1.220]	44.2 [1.740]	54.5 [2.146]				

Note: The values show the horizontal lead wire type.
The vertical lead wire type is 0.5mm [0.020in.] longer.

● Reed switch type: Single acting push type

mm [in.]

Code	Bore size 20 [0.787]		32 [1.260]		40 [1.575]	
	4.5	7.5	14	21	27	34
X	4.5 [0.177]	7.5 [0.295]	14 [0.551]	21 [0.827]	27 [1.063]	34 [1.339]
Y	11.5 [0.453]	21.5 [0.846]	27 [1.063]	37 [1.457]	42 [1.654]	47 [1.850]
Z ^{Note}	9 [0.354]	19 [0.748]	24.5 [0.965]	34.5 [1.358]	39.5 [1.555]	44.5 [1.752]

Note: The values show the horizontal lead wire type.
The vertical lead wire type is 0.5mm [0.020in.] longer.

When Mounting DJ Cylinders with Sensor Switches in Close Proximity

● If mounting a multiple number of DJ cylinders with sensor switches in close proximity to each other, always preserve spacing intervals for mounting as shown below to prevent mutual magnetic interference.

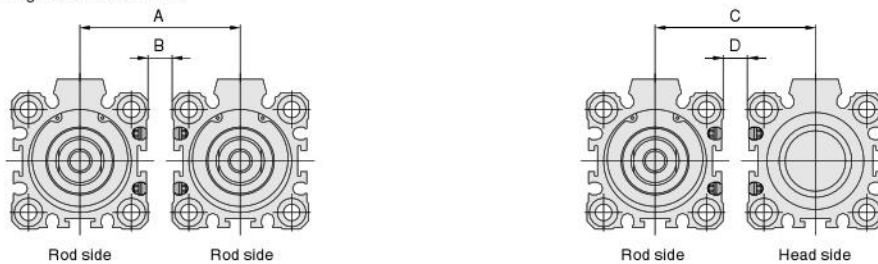

Bore size	Solid state type				Reed switch type			
	A	B	C	D	A	B	C	D
20 [0.787]	41 [1.61]	5 [0.20]	43 [1.69]	7 [0.28]	36 [1.42]	0	41 [1.61]	5 [0.20]
32 [1.260]	56 [2.20]	11 [0.43]	56 [2.20]	11 [0.43]	45 [1.77]	0	59 [2.32]	14 [0.55]
40 [1.575]	64 [2.52]	12 [0.47]	64 [2.52]	12 [0.47]	58 [2.28]	6 [0.24]	67 [2.64]	15 [0.59]
50 [1.969]	79 [3.11]	15 [0.59]	79 [3.11]	15 [0.59]	64 [2.52]	0	80 [3.15]	16 [0.63]

mm [in.]

Discontinued