

Strength

Simplicity

KOGANEI holders and column tubes keep your production lines operating smoothly. These flexible support devices are compatible with a wide range of designs and configurations.

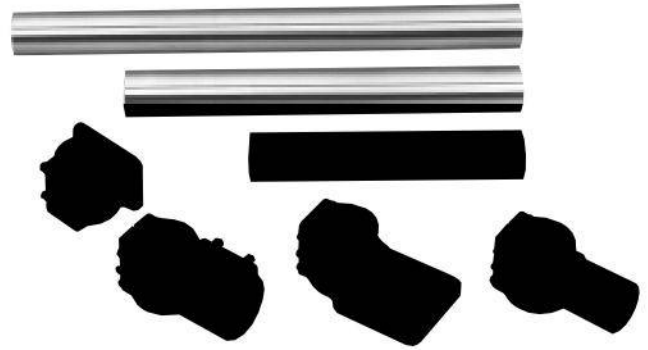

DB1, DB2, DB3 Column Tubes

- Material: Mild steel (zinc-plated)
- Mass: 1.6kg (DB1), 2.5kg (DB2), 3.3kg (DB3)

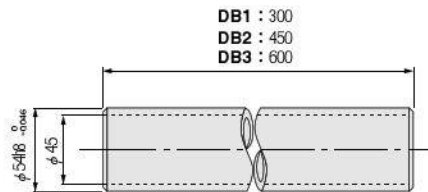

DH1 Holder

- Material: Aluminum alloy casting (painted black)
- Mass: 0.5kg

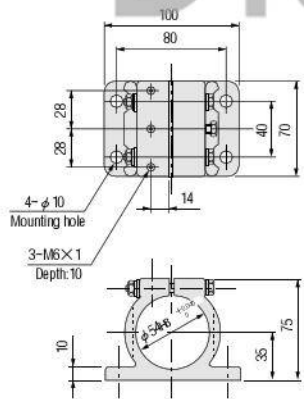

DH2 Holder

- Material: Aluminum alloy casting (painted black)
- Mass: 0.8kg

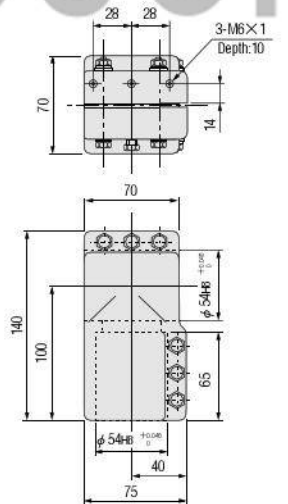

DH3 Holder

- Material: Aluminum alloy casting (painted black)
- Mass: 0.8kg

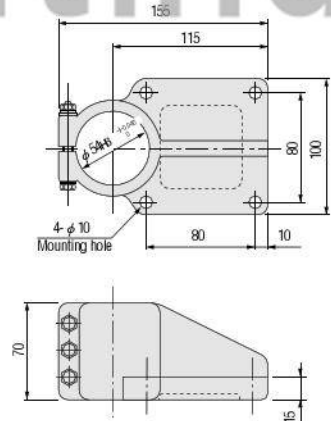

DH4 Holder

- Material: Aluminum alloy casting (painted black)
- Mass: 0.6kg

