

DYNA CYLINDERS

*Ultra-reliable, high-function
tie-rod cylinder*

The DYNA cylinders, compact and lightweight mid-sized actuators compatible with ISO standards, offer a wide range of configurations and mounting types to meet various application requirements in a flexible manner.

Moreover, the use of a new type of cushion needle and floating seal have made these products user-friendlier.

*Light
&
Compact*

Product Line Up

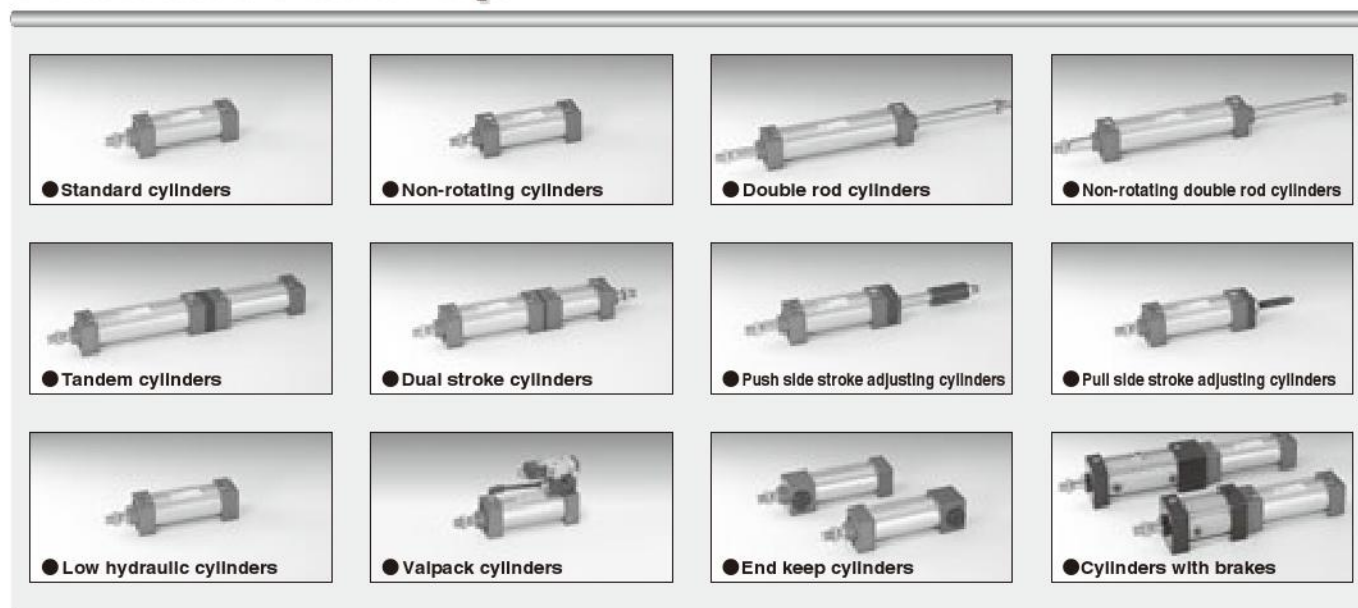

Mounting type

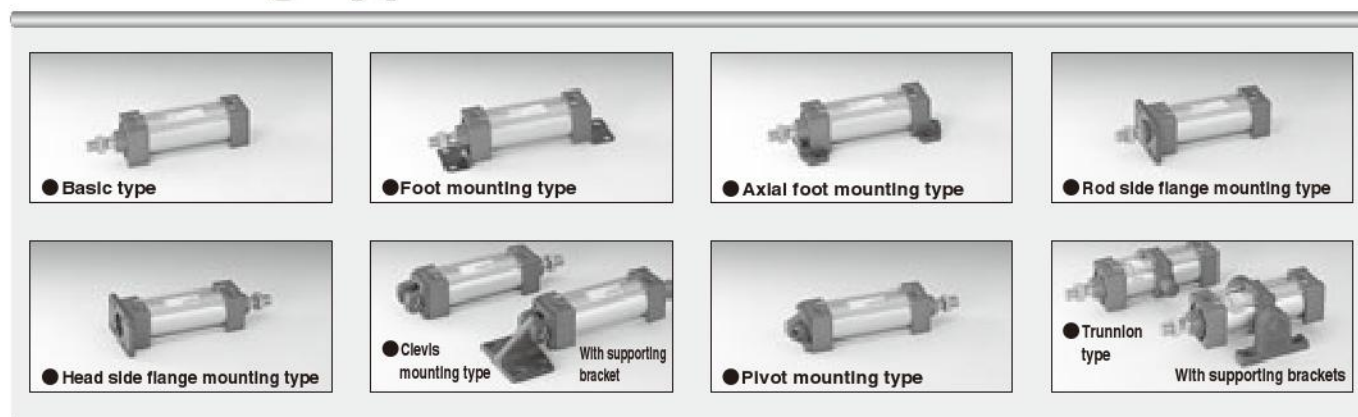

Accessory

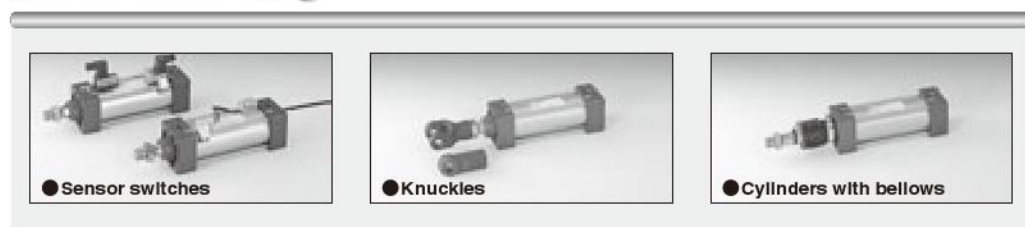

design in the smallest standard size for a mid-sized,

1 Extensive variation of functions

■ The series configuration together with its versatile functionality and specifications offers the best match for various mechanical devices.

2 Improved cushioning

■ Improved cushioning is gained by utilizing floating seal in the cushion section.

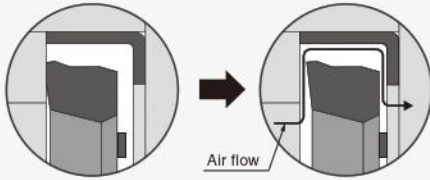

3 Long life

■ Oil impregnated sintered copper alloy in bushings enables stable operation and longer life.

4 New cushion needle

■ Using a new type of cushion needle that is completely embedded in the cylinder body offers fine adjustment for better performance.

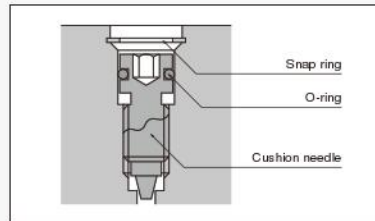

5 Safe self-locking mechanism

■ New release of cylinders with brakes. Exhausting compressed air pushes a brake shoe against the piston rod thereby stopping the cylinder.

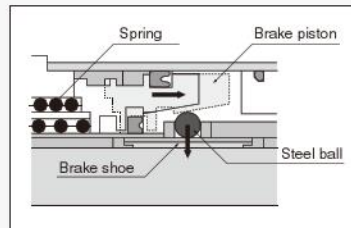

※ Steel balls and a brake shoe are secured in position. Operating the brake piston enables activation or release of the brake.

Series configurations

	Basic type	Foot mounting type	Axial foot mounting type	Rod side flange mounting type	Head side flange mounting type	Ceiling mounting type (with supporting brackets)	Pivot mounting type	Tandem type (with supporting brackets)
Standard cylinder ($\phi 32$ [1.260]~ $\phi 125$ [4.921])	●	●	●	●	●	●	●	●
Non-rotating cylinder ($\phi 40$ [1.575]~ $\phi 100$ [3.940])	●	●	●	●	●	●	●	●
Double rod cylinder ($\phi 32$ [1.260]~ $\phi 125$ [4.921])	●	●	●	●	●	●	●	●
Non-rotating double rod cylinder ($\phi 40$ [1.575]~ $\phi 100$ [3.940])	●	●	●	●	●	●	●	●
Tandem cylinder ($\phi 40$ [1.575]~ $\phi 100$ [3.940])	●	●	●	●	●	●	●	●
Dual stroke cylinder ($\phi 40$ [1.575]~ $\phi 100$ [3.940])	●	●	●	●	●	●	●	●
Push side stroke adjusting cylinder ($\phi 40$ [1.575]~ $\phi 100$ [3.940])	●	●	●	●	●	●	●	●
Pull side stroke adjusting cylinder ($\phi 40$ [1.575]~ $\phi 100$ [3.940])	●	●	●	●	●	●	●	●
Low hydraulic cylinder ($\phi 32$ [1.260]~ $\phi 100$ [3.940])	●	●	●	●	●	●	●	●
Valpack cylinder ($\phi 40$ [1.575]~ $\phi 100$ [3.940])	●	●	●	●	●	●	●	●
End keep cylinder ($\phi 40$ [1.575]~ $\phi 100$ [3.940])	●	●	●	●	●	●	●	●
Cylinder with brake ($\phi 40$ [1.575]~ $\phi 100$ [3.940])	●	●	●	●	●	●	●	●

mm [in.]

Handling Instructions and Precautions



General precautions

Media

1. Use air for the media. For the use of any other media, consult us.
2. Air used for the DYNA cylinder should be clean air that contains no deteriorated compressor oil, water, dust, etc. Install an air filter (filtration of a minimum 40 μm) near the cylinder or valve to remove collected liquid or dust. In addition, drain the air filter periodically.

Piping

Always thoroughly blow off (use compressed air) the tubing before connecting it to the DYNA cylinder. Entering chips, sealing tape, rust, etc., generated during piping work could result in air leaks or other defective operation.

Atmosphere

If using in locations subject to dripping water, dripping oil, etc., or to large amounts of dust, use a cover to protect the unit.

Lubrication

This equipment can be used without lubrication. If lubrication is required, use Turbine Oil Class 1 (ISO VG32) or lithium soap-based grease No.2 or equivalent.



Handling

Assembly of mounting bracket

Use mounting screws which are supplied with the bracket to assemble the mounting bracket. Use an Allen wrench to tighten the mounting screws evenly. When 4 screws are used, tighten diagonally from each corner. The tightening torque is shown below.

Assembly and disassembly

For disassembly, insert an Allen wrench to loosen the tie rod nut, and remove the cover.

For assembly, screw in the tie rod nut with the hexagon socket facing outward. Evenly tighten diagonally from each corner. The tightening torque is shown below.

<Tightening torque of mounting brackets and tie rod nuts>

Bore size mm [in.]	Tightening torque
32, 40, 50 [1.260, 1.575, 1.969]	4.81N·m [3.55ft·lbf]
63 [2.480]	12.0N·m [8.85ft·lbf]
80, 100 [3.150, 3.940]	24.0N·m [17.7ft·lbf]
125 [4.921]	42.2N·m [31.1ft·lbf]

● Width across flats of hexagon socket mm [in.]

Bore size	Tie rod nut	Mounting bracket
32 [1.260]	6 [0.236]	4 [0.157]
40, 50 [1.575, 1.969]	6 [0.236]	4 [0.157]
63 [2.480]	8 [0.315]	5 [0.197]
80, 100 [3.150, 3.940]	10 [0.394]	6 [0.236]
125 [4.921]	12 [0.472]	8 [0.315]

● φ 32 [1.260in.]

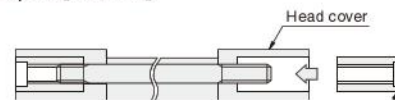

Use hexagon socket tie rod nuts on both sides for only 32φ

● φ 40 [1.575in.]~ φ 125 [4.921in.]

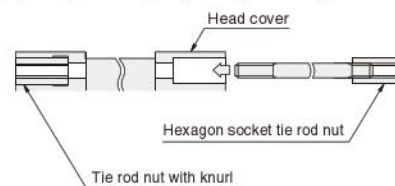



Manual operation of end keep cylinder locking mechanism

While the locking mechanism is normally released automatically through cylinder operations, it can also be released manually. For manual release, insert an M4×0.7 screw that has 30mm [1.18in.] screw length into the manual override opening, thread it in about 3 turns into the internal lock piston, and then pull up the screw. To maintain the manual override for adjustment, etc., thread the locknut onto the screw and, with the locking mechanism in a released state, tighten the locknut against the cylinder.

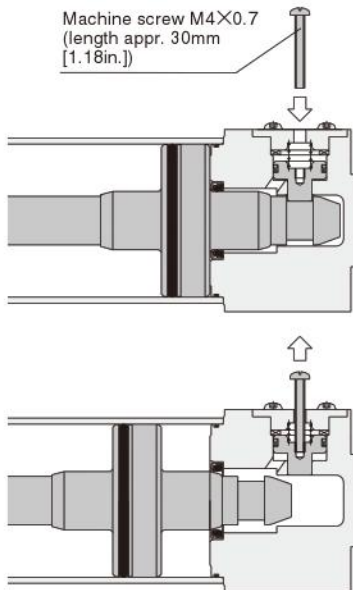

- Cautions:**
1. It is dangerous to release the lock when load (weight) is present on the piston rod, because it may cause the unintended piston rod's extension (or retraction). In this case, always supply air to the connection port opposite the one adjacent to the locking mechanism before releasing the locking mechanism.
 2. If the locking mechanism cannot easily be released even with manual override, it could be the result of galling of the lock piston and piston rod. In this case, supply air to the connection port opposite the one adjacent to the locking mechanism before releasing the locking mechanism.
 3. Because water, oil, dust, etc., intruding through the manual override opening may be a cause of defective locks or other erratic operation. If using in locations subject to dripping water, dripping oil, etc., or large amounts of dust, use a cover to protect the unit.
 4. If the circuit cannot maintain exhaust pressure at 0.03MPa [4.4psi.] or less due to using a manifold valve, use individual valve for operations.

Dedicated muffler

The dedicated muffler can be mounted on the manual override opening.
Dedicated muffler model SA-5 (mm)

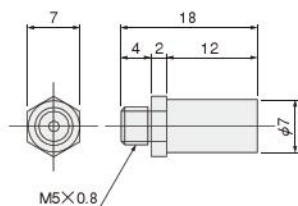

Control circuit for the end keep cylinder

1. For control of the DYNA end keep cylinders, we recommend the use of 2-position, 4-, 5-port valves. Avoid the use of control circuit of ABR connections (exhaust centers) with 3-position valves that exhaust air from 2 ports.
2. Always use meter-out control for speed control. Meter-in control may result in failure of the locking mechanism to release.
3. Always set the air pressure to 0.15MPa [22psi.] or more.

- Cautions:**
1. It is dangerous to supply air to a connection port on a side with a locking mechanism while the cylinder has already been exhausted, because the piston rod may suddenly extend (or retract). In addition, since the lock piston could also cause galling of the lock piston and piston rod, resulting in defective operation. Always supply air to the connection port on the opposite side of the locking mechanism to ensure applying back pressure.
 2. When restarting operations after air has been exhausted from the cylinder due to completion of operations or to an emergency stop, always start by supplying air to a connection port on the opposite side of the locking mechanism.
 3. Connect the valve port A (NC) to the connection port on the side with the locking mechanism.

Handling Instructions and Precautions



Mounting and piping (for cylinder with brake)

Operating principle

The cylinder with brake uses a mechanism that consists of steel balls contacting an incline and it receives components of a spring force, then it transmits the force via a brake shoe to apply to the piston rod.

● When the brake is released

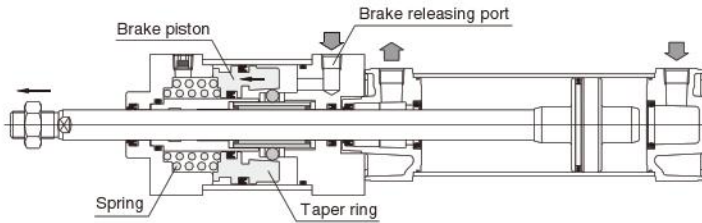

● When the brake is applied

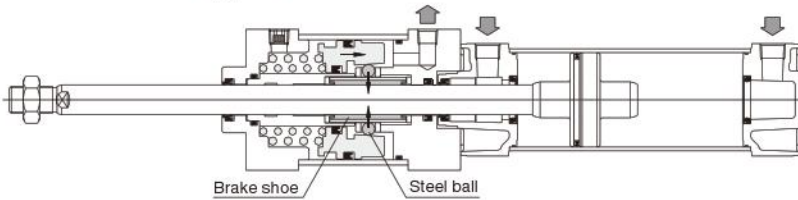

Precautions for Installation

1. In the cylinder with brake, the brake piston in the single brake type is secured in place with 2 hexagon socket screws, and in the double brake type with 4 such screws, with the brake set in a released state at shipping.

When piping and installation is completed, or when performing operation checks, first supply at least 0.35MPa [51psi.] (0.4MPa [58psi.] for bore size of $\phi 50$ [1.969in.]) of air to the brake release port, and remove the screws. Then exhausting the compressed air enables the piston rod to be held. While the unit could be operated with the screws removed, it is better for prevention of entering dust to use screws with nuts to secure it in place by inserting 2 or 3 thread ridges into the cylinder.

At this time, do not excessively tighten the screws as they could interfere with the brake piston, by re-locking it in place, or by constricting its movements.

2. Poor centering of the Cylinder with Brake may damage the seal or hasten wear on the brake shoe.

As poor centering could also result in inaccuracy of the stopping position, use of a cylinder joint is recommended.

When the brake is released

A supply of compressed air from the brake releasing port causes the brake piston including the taper ring, to retract thereby freeing the steel balls from the taper ring, which releases the brake and lets the piston rod freely slide.

When the brake is applied

Exhausting compressed air from the brake releasing port causes the spring to press against the brake piston, transmitting components of spring force via the taper ring to the steel balls, which then works via the brake shoe to transmit a perpendicular force to the piston rod and to apply friction force to the brake.

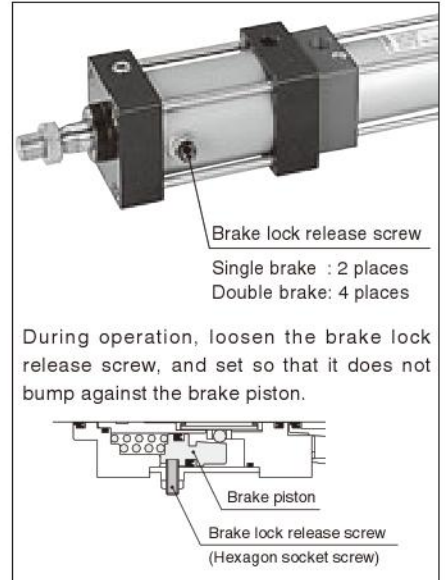



Mounting and piping (for cylinder with brake)

Control circuit

Electric control

When using a sequencer for control, the scanning time of the sequencer will affect the stopping position error. To improve the stopping position accuracy, use a TTL circuit, etc., to directly control the signal from the cylinder's sensor switch, and operate the valve.

Pneumatic circuit

1. To achieve a balance with the load, and a balance of differences in rod diameter area, always use a regulator with check valve.
2. For the cylinder control solenoid valve (V1), use a PAB connection 3-position solenoid valve, etc.
3. Install the solenoid valve for the brake (V2) as close to the cylinder as possible. Moreover, using a DC current solenoid valve will improve response (stopping position accuracy).

Example of basic circuit (Reference)

● Horizontal mounting Spring lock

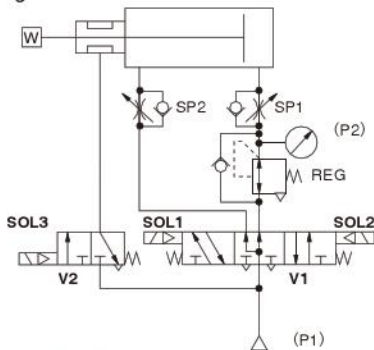

Regulator pressure setting

$$P2 = \frac{D^2 - d^2}{D^2} \cdot P1$$

D : Cylinder bore size (mm)
d : Rod diameter (mm)
P1 : Supply pressure (MPa)

Regulator pressure setting

$$P2' = \frac{D'^2 - d'^2}{D'^2} \cdot P1'$$

D' : Cylinder bore size [in.]
d' : Rod diameter [in.]
P1' : Supply pressure [psi]

● Vertical mounting Spring lock

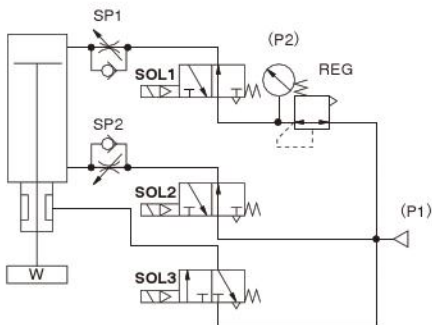

Regulator pressure setting

$$P2 = \frac{\pi (D^2 - d^2) P1 - 4W}{\pi \cdot D^2}$$

D : Cylinder bore size (mm)
d : Rod diameter (mm)
P1 : Supply pressure (MPa)
W : Load (N)

Regulator pressure setting

$$P2' = \frac{\pi (D'^2 - d'^2) P1' - 4W'}{\pi \cdot D'^2}$$

D' : Cylinder bore size [in.]
d' : Rod diameter [in.]
P1' : Supply pressure [psi]
W' : Load [lbf]

● Vertical mounting (push up)

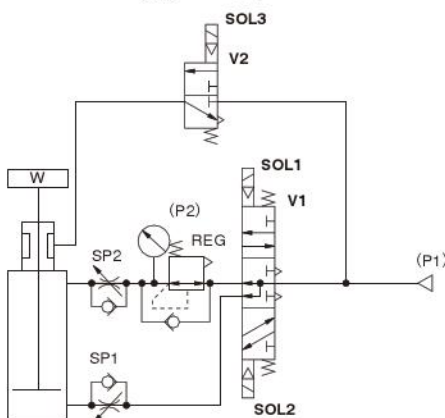

Regulator pressure setting

$$P2 = \frac{\pi \cdot D^2 \cdot P1 - 4W}{\pi (D^2 - d^2)}$$

D : Cylinder bore size (mm)
d : Rod diameter (mm)
P1 : Supply pressure (MPa)
W : Load (N)

Regulator pressure setting

$$P2' = \frac{\pi \cdot D'^2 \cdot P1' - 4W'}{\pi (D'^2 - d'^2)}$$

D' : Cylinder bore size [in.]
d' : Rod diameter [in.]
P1' : Supply pressure [psi]
W' : Load [lbf]

ON, OFF switch sequence for solenoid (same for all mounting positions)

Valve	V1			V2
	SOL1	SOL2	SOL3	
Operating state	ON	OFF	OFF	OFF
Intermediate stop	OFF	OFF	OFF	OFF
Forward	OFF	ON	ON	ON
Reverse	ON	OFF	ON	ON

Air Flow Rate and Air Consumption

While the air cylinder's air flow rate and air consumption can be found through the following calculations, the quick reference chart to the right provides the answers more conveniently.

$$\text{Air flow rate } Q_1 = \frac{\pi D^2}{4} \times L \times \frac{60}{t} \times \frac{P+0.1013}{0.1013} \times 10^{-6}$$

$$\text{Air consumption } Q_2 = \frac{\pi D^2}{4} \times L \times 2 \times n \times \frac{P+0.1013}{0.1013} \times 10^{-6}$$

- Q₁ : Required air flow rate for cylinder ℓ /min(ANR)
- Q₂ : Air consumption of cylinder ℓ /min(ANR)
- D : Cylinder tube inner diameter mm
- L : Cylinder stroke mm
- t : Time required for cylinder to travel 1 stroke s
- n : Number of cylinder reciprocations per minute times/min
- P : Pressure MPa

$$\text{Air flow rate } Q_1' = \frac{\pi D'^2}{4} \times L' \times \frac{60}{t} \times \frac{P'+14.696}{14.696} \times \frac{1}{1728}$$

$$\text{Air consumption } Q_2' = \frac{\pi D'^2}{4} \times L' \times 2 \times n \times \frac{P'+14.696}{14.696} \times \frac{1}{1728}$$

- Q₁' : Required air flow rate for cylinder ft.³/min.(ANR)**
- Q₂' : Air consumption of cylinder ft.³/min.(ANR)**
- D' : Cylinder tube inner diameter in.
- L' : Cylinder stroke in.
- t : Time required for cylinder to travel 1 stroke sec.
- n : Number of cylinder reciprocations per minute times/min
- P' : Pressure psi.

* Refer to p.54 for an explanation of ANR.

Air consumption for each 1mm [0.0394in.] stroke cm³ [in.³]/Reciprocation (ANR)

Bore size mm [in.]	Air pressure MPa [psi.]								
	0.1 [15]	0.2 [29]	0.3 [44]	0.4 [58]	0.5 [73]	0.6 [87]	0.7 [102]	0.8 [116]	0.9 [131]
32 [1.260]	3.20 [0.1953]	4.78 [0.2917]	6.37 [0.3887]	7.96 [0.4858]	9.55 [0.5828]	11.14 [0.6798]	12.72 [0.7762]	14.31 [0.8733]	15.90 [0.9703]
40 [1.575]	4.99 [0.3045]	7.48 [0.4565]	9.96 [0.6078]	12.44 [0.7591]	14.92 [0.9105]	17.40 [1.0618]	19.88 [1.2132]	22.36 [1.3645]	24.84 [1.5158]
50 [1.969]	7.80 [0.4760]	11.68 [0.7128]	15.56 [0.9495]	19.43 [1.1857]	23.31 [1.4225]	27.19 [1.6592]	31.06 [1.8954]	34.93 [2.1316]	38.78 [2.3685]
63 [2.480]	12.39 [0.7561]	18.54 [1.1314]	24.70 [1.5073]	30.85 [1.8826]	37.01 [2.2585]	43.16 [2.6338]	49.32 [3.0097]	55.46 [3.3844]	61.57 [3.7572]
80 [3.150]	19.98 [1.2193]	29.90 [1.8246]	39.83 [2.4306]	49.75 [3.0359]	59.67 [3.6413]	69.60 [4.2473]	79.52 [4.8526]	89.45 [5.4586]	99.37 [6.0640]
100 [3.940]	31.21 [1.9046]	46.72 [2.8510]	62.23 [3.7975]	77.73 [4.7434]	93.24 [5.6899]	108.75 [6.6364]	124.25 [7.5822]	139.76 [8.5287]	155.27 [9.4752]
125 [4.921]	48.77 [2.9761]	73.00 [4.4548]	97.23 [5.9334]	121.46 [7.4120]	145.69 [8.8906]	169.92 [10.369]	194.14 [11.847]	218.37 [13.326]	242.60 [14.804]

The figures in the table show the air flow rate and air consumption when an air cylinder makes 1 reciprocation with stroke of 1mm [0.0394in.]. The air flow rate and consumption actually required is found by the following calculations.

- Finding the air flow rate (for selecting F.R.L., valves, etc.)
Example: When operating an air cylinder with bore size of 40mm [1.575in.] at speed of 300mm/s [11.8in./sec.], and under air pressure of 0.5MPa [73psi.]

$$14.92 \times \frac{1}{2} \times 300 \times 10^{-3} \div 2.24 = 2.24 \text{ ℓ / s [0.0791ft.³/sec.]} \text{ (ANR)}$$

(At this time, the air flow rate per minute is $14.92 \times \frac{1}{2} \times 300 \times 60 \times 10^{-3} = 134.28 \text{ ℓ /min [4.74ft.³/min.]} \text{ (ANR).}$)

- Finding the air consumption
Example 1. When operating an air cylinder with bore size of 40mm [1.575in.] and stroke of 100mm [3.94in.], and under air pressure of 0.5MPa [73psi.], for 1 reciprocation

$$14.92 \times 100 \times 10^{-3} = 1.492 \text{ ℓ [0.0527ft.³$$

- Example 2. When operating an air cylinder with bore size of 40mm [1.575in.] and stroke of 100mm [3.94in.], and under air pressure of 0.5MPa [73psi.], for 10 reciprocations per minute

$$14.92 \times 100 \times 10 \times 10^{-3} = 14.92 \text{ ℓ /min [0.527ft.³/min.]} \text{ (ANR)}$$

Cylinder Thrust

Select a suitable cylinder bore size considering the load and air pressure to obtain the required thrust.

Since the figures in the table are calculated values, select a bore size that results in a load ratio (load ratio = $\frac{\text{Load}}{\text{Calculated value}}$) of 70% or less (50% or less for high speed application).

Bore size mm [in.]	Rod diameter mm [in.]	Operation	Pressure area mm ² [in. ²]	Air pressure MPa [psi.]										
				0.1 [15]	0.2 [29]	0.3 [44]	0.4 [58]	0.5 [73]	0.6 [87]	0.7 [102]	0.8 [116]	0.9 [131]	1 [145]	
32 [1.260]	12 [0.472]	Push side	804 [1.246]	80 [18.0]	161 [36.2]	241 [54.2]	322 [72.4]	402 [90.4]	482 [108]	563 [127]	643 [145]	724 [163]	804 [181]	
		Pull side	690 [1.070]	69 [15.5]	138 [31.0]	207 [46.5]	276 [62.0]	345 [77.6]	414 [93.1]	483 [109]	552 [124]	621 [140]	690 [155]	
40 [1.575]	16 [0.630]	Push side	1256 [1.947]	126 [28.3]	251 [56.4]	377 [84.7]	502 [113]	628 [141]	754 [169]	879 [198]	1005 [226]	1130 [254]	1256 [282]	
		Pull side	1055 [1.635]	106 [23.8]	211 [47.4]	317 [71.3]	422 [94.9]	528 [119]	633 [142]	739 [166]	844 [190]	950 [214]	1055 [237]	
50 [1.969]	20 [0.787]	Push side	1963 [3.043]	196 [44.1]	393 [88.3]	589 [132]	785 [176]	982 [221]	1178 [265]	1374 [309]	1570 [353]	1767 [397]	1963 [441]	
		Pull side	1649 [2.556]	165 [37.1]	330 [74.2]	495 [111]	660 [148]	825 [185]	989 [222]	1154 [259]	1319 [297]	1484 [334]	1649 [371]	
63 [2.480]	20 [0.787]	Push side	3117 [4.831]	312 [70.1]	623 [140]	935 [210]	1247 [280]	1559 [350]	1870 [420]	2182 [491]	2494 [561]	2805 [631]	3117 [701]	
		Pull side	2803 [4.345]	280 [62.9]	561 [126]	841 [189]	1121 [252]	1402 [315]	1682 [378]	1962 [380]	2242 [504]	2523 [567]	2803 [630]	
80 [3.150]	25 [0.984]	Push side	5026 [7.790]	503 [113]	1005 [226]	1508 [339]	2010 [452]	2513 [565]	3016 [678]	3518 [791]	4021 [904]	4523 [1017]	5026 [1130]	
		Pull side	4536 [7.031]	454 [102]	907 [204]	1361 [306]	1814 [408]	2268 [510]	2722 [612]	3175 [714]	3629 [816]	4082 [918]	4536 [1020]	
100 [3.940]	30 [1.181]	Push side	7853 [12.17]	785 [176]	1571 [353]	2356 [530]	3141 [706]	3927 [883]	4712 [1059]	5497 [1236]	6282 [1412]	7068 [1589]	7853 [1765]	
		Pull side	7147 [11.08]	715 [161]	1429 [321]	2144 [482]	2859 [643]	3574 [803]	4288 [964]	5003 [1125]	5718 [1285]	6432 [1446]	7147 [1607]	
125 [4.921]	35 [1.378]	Push side	12271 [19.02]	1227 [276]	2454 [552]	3681 [827]	4908 [1103]	6136 [1379]	7363 [1655]	8590 [1931]	9817 [2207]	11044 [2483]	12271 [2759]	
		Pull side	11310 [17.53]	1131 [254]	2262 [508]	3393 [763]	4524 [1017]	5655 [1251]	6786 [1525]	7917 [1780]	9048 [2034]	10179 [2288]	11310 [2542]	

DYNA VALPACK CYLINDERS

Symbol

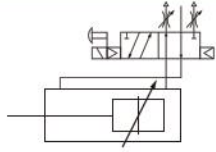

Specifications

Item	Bore size mm [in.]	40 [1.575]	50 [1.969]	63 [2.480]	80 [3.150]	100 [3.940]
Operation type		Double acting type				
Media		Air				
Mounting type		Basic type, Foot type, Axial foot type, Rod side flange type, Head side flange type, Clevis type, Pivot type, Trunnion type				
Operating pressure range MPa [psi.]		0.17~0.7 [25~102]				
Proof pressure MPa [psi.]		1.05 [152]				
Operating temperature range °C [°F]		5~50 [41~122]				
Operating speed range mm/s [in./sec.]		50~500 [2.0~19.7]			50~300 [2.0~11.8]	
Speed controller		Exhaust throttle valve (2-way) is standard equipment				
Cushion stroke mm [in.]		16 [0.630]	20 [0.787]	25 [0.984]		
Lubrication		Not required (If lubrication is required, use Turbine Oil Class 1 (ISO VG32) or equivalent.)				
Port size	Rc	3/8				

Solenoid Valve Specifications

Item	Series	350 series
Solenoid specification		Single solenoid
Model		VP350-4E1-70
Operation type		Indirect operation
Number of positions and ports		2 positions, 5 ports
Effective area [Cv]	mm ²	26.5 [1.47]
Port size	Rc	1/4
Lubrication		Not required
Operating pressure range MPa [psi.]		0.17~0.7 [25~102]
Proof pressure MPa [psi.]		1.1 [160]
Operating temperature range °C [°F]		5~50 [41~122]
Shock resistance	G	90
Mounting direction		Any
Maximum operating frequency	cycle/s	5

Order Codes

DDV 50×100 — — — — — — AC100V — — Number of sensor switches

Bore size × Stroke

Bellocs
Blank — No bellocs
J — With bellocs

Types of bellocs
JT — Nylon tarpaulin (~80°C [176°F])
JC — Chloroprene (~100°C [212°F])
JK — Conex (~200°C [392°F])
JA — Alumix (~250°C [482°F])
● Conex is a registered trademark of Teijin, Inc.
● The temperatures shown are the bellocs' own durable temperatures, and are not temperatures for cylinder use.

Tube material
Blank — Standard
FT — Steel tube specification (Not available for cylinder with magnet.)

Mounting type
Blank — Basic type
1 — Foot mounting type
2 — Axial foot mounting type
3 — Rod side flange mounting type
5 — Head side flange mounting type
7 — Clevis mounting type (with pin)
7-7C — Clevis mounting type (with supporting bracket)
8 — Pivot mounting type
11 — Trunnion type
11-11T — Trunnion type (with supporting brackets)
● Mounting brackets are already assembled at shipping.
● Orders for mounting brackets only are also accepted.

Voltage
AC100V
AC200V
DC24V
● Single unit valve order code VP350-4E1-70-Voltage
● 2 pcs. standard speed controllers are included.

Lead wire length
A — 1000mm [39in.]
B — 3000mm [118in.]

Sensor switch (For cylinder with magnet)
ZC130 — 2-lead wire Solid state type with indicator lamp DC10~28V
ZC153 — 3-lead wire Solid state type with indicator lamp DC4.5~28V
CS5T — 2-lead wire Reed switch type without indicator lamp DC5~28V AC85~115V
CS11T — 2-lead wire Reed switch type with indicator lamp DC10~28V
CS2F — DIN type Reed switch type with indicator lamp AC85~230V
CS3F — DIN type Reed switch type with indicator lamp DC10~30V
CS4F — DIN type Reed switch type with indicator lamp DC10~30V
CS5F — DIN type Reed switch type without indicator lamp DC3~30V
● For mounting location of sensor switch, see p.534.
● CS□F comes with a DIN connector. All others are grommet type.
● Orders for sensor switches only are also accepted.

Rod end accessory
Blank — No rod end accessory
Y — With Y type knuckle (with pin)
I — With I type knuckle
● For the cylinder joint and cylinder rod end, see p.1568.
● Orders for rod end accessories only are also accepted.
● For dimensions of rod end accessories, see p.537.

DYNA Valpack cylinder

Remarks: 1. The order code of the valpack valve only is VP350-4E1-70-Voltage.
2. For made to order valves, or for double solenoid, 3-position, locking type manual override, plug connector, DIN connector, or LED indicator, consult us.



Bore Size and Stroke

Bore size	Standard strokes	Maximum available stroke
40	50 ^{Note} , 75, 100, 150, 200, 250, 300, 350, 400, 450, 500, 600, 700, 800	1000
50		
63	50 ^{Note} , 75, 100, 150, 200, 250, 300, 350, 400	1500
80	450, 500, 600, 700, 800, 900, 1000	
100		

Remarks: 1. Stroke tolerance; Strokes of 250 or less: ${}^+1_0 [{}^{+0.039}_{0} \text{in.}]$, strokes of 251~1000: ${}^{+1.5}_0 [{}^{+0.059}_{0} \text{in.}]$, and strokes of 1001 or more: ${}^{+2.0}_0 [{}^{+0.079}_{0} \text{in.}]$.
2. For non-standard strokes, consult us.
3. Cylinders with magnets are not available for steel tube specification.
4. For the maximum available stroke with bellows specification, see p.538.

Note: Not available for trunnion type.

Solenoid Specifications

Item	Rated voltage	AC100V	AC200V	DC24V		
Type		Shading type		Flywheel diode incorporated for surge suppression		
Operating voltage range V		90~132 (100 $_{-10}^{+32}$ %)	180~264 (200 $_{-10}^{+32}$ %)	21.6~26.4 (24 \pm 10%)		
Current (When rated voltage applied)	Frequency Hz	50	60	50	60	—
	Starting mA(r.m.s.)	34	32	17	16	—
	Energizing mA(r.m.s.)	22	20	11	10	65(1.6W)
Maximum allowable leakage current mA		4	2	2	4	
Insulation type		B type				
Insulation resistance MΩ		Min. 100				
Wiring and lead wire length		Grommet type: 300mm [11.8in.]				
Color of lead wire		Yellow	White	Red(+), Black(-)		
Surge suppression		Built-in varistor (made to order)		Flywheel diode (standard equipment)		

Inner Construction and Major Parts

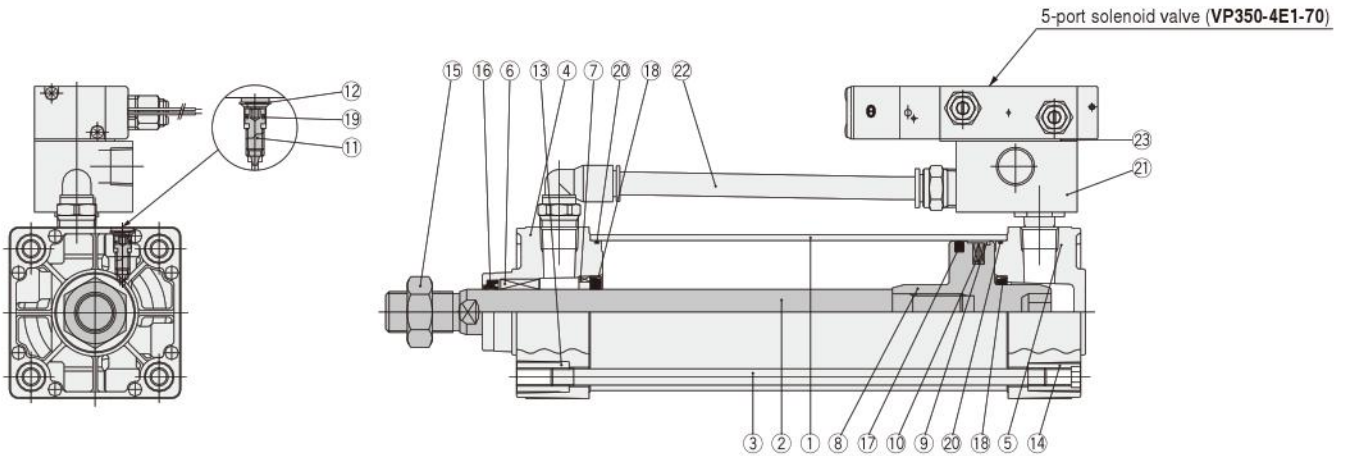

Seals

Parts	Rod seal	Piston seal	Cushion seal	Tube gasket	Cushion gasket
Bore size mm	1★	1★	2	2★	2
40	DRP16	PWP40N	CPF20	1.5X40	S5
50	DRP20	PWP50N	CPF24	1.5X50	S6
63	DRP20	PWP63N	CPF24	1.5X63	S6
80	DRP25	PWP80N	CPF30	1.5X80	S6
100	DRP30	PWP100N	CPF35	1.5X100	S6

Remark: Items marked with a star (★) are available as repair kits.
Order code: For valpack cylinders...SRK-ND DV [Bore size]

Switching from Push to Pull Type Cylinder When Energizing

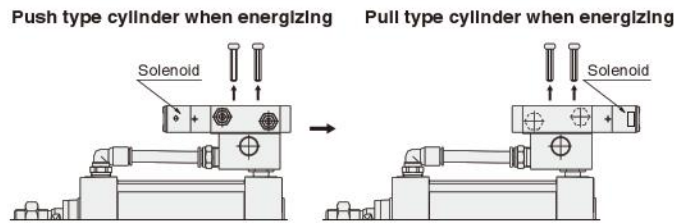

Remove the valve mounting screws, turn the valve 180°, and re-assemble. At this time, confirm that the valve adapter gasket is in the designated position between the valve and the valve adapter.

Major Parts and Materials

No.	Parts	Materials
①	Cylinder tube	Aluminum alloy, and steel tube specification is steel
②	Piston rod	φ 32:Stainless steel, φ 40~φ 125:Carbon steel for machine structural use
③	Tie rod	Carbon steel for machine structural use
④	Rod cover	Aluminum die-casting
⑤	Head cover	Aluminum die-casting
⑥	Rod bushing	Oil impregnated sintered copper alloy
⑦	Keep ring	Aluminum alloy
⑧	Piston	Aluminum alloy
⑨	Wear ring	Plastic
⑩	Magnet	Rubber magnet
⑪	Cushion needle	Carbon steel for machine structural use
⑫	Snap ring	Spring steel
⑬	Tie rod nut R	Rolled steel for general structural use
⑭	Tie rod nut H	Chrome-molybdenum steel
⑮	Rod end nut	Rolled steel for general structural use
⑯	Rod seal	Synthetic rubber (NBR)

No.	Parts	Materials
⑰	Piston seal	Synthetic rubber (NBR)
⑱	Cushion seal	Synthetic rubber (NBR)
⑲	Cushion gasket	Synthetic rubber (NBR)
⑳	Tube gasket	Synthetic rubber (NBR)
㉑	Valve adapter	Aluminum alloy
㉒	Bypass tube	Nylon tube
㉓	Valve adapter gasket	Synthetic rubber (NBR)
—	Foot mounting bracket	Rolled steel for general structural use
—	Axial foot mounting bracket	Cast iron
—	Flange mounting bracket	Rolled steel for general structural use
—	Clevis mounting bracket	Cast iron
—	Clevis supporting bracket	Cast iron
—	Pivot mounting bracket	Cast iron
—	Trunnion bracket	Cast iron
—	Trunnion supporting bracket	Cast iron
—	Knuckles	Cast iron

Mass

Bore size mm [in.]	Zero stroke mass									Additional mass for each 1mm [0.0394in.] stroke	Mass of 1 sensor switch [with holder]		Mass of knuckle	
	Basic type	Foot mounting type	Axial foot mounting type	Flange mounting type	Clevis mtg. type (with pin)	Clevis mtg. type (w. supporting bkt.)	Pivot mounting type	Trunnion type	Trunnion type (w. supporting bkt.)		ZCS□H Note	CS□F	Y type knuckle (with pin)	I type knuckle
40 [1.575]	0.89 [1.96] (0.93 [2.05])	1.02 [2.25] (1.06 [2.34])	1.09 [2.40] (1.13 [2.49])	1.26 [2.78] (1.30 [2.87])	1.16 [2.56] (1.20 [2.65])	1.86 [4.10] (1.90 [4.19])	1.07 [2.36] (1.11 [2.45])	1.37 [3.02] (1.41 [3.11])	1.87 [4.12] (1.91 [4.21])	0.00300 [0.0662] (0.00730 [0.1616])	0.04 [0.09]	0.05 [0.11]	0.27 [0.60] 0.34 [0.75]	0.16 [0.35] 0.21 [0.46]
50 [1.969]	1.26 [2.78] (1.32 [2.91])	1.43 [3.15] (1.49 [3.29])	1.58 [3.48] (1.64 [3.62])	1.65 [3.64] (1.71 [3.77])	1.65 [3.64] (1.71 [3.77])	2.35 [5.16] (2.41 [5.31])	1.52 [3.35] (1.58 [3.48])	1.81 [3.98] (1.87 [4.12])	2.31 [5.09] (2.37 [5.23])	0.00428 [0.0944] (0.01068 [0.2355])	0.04 [0.09]	0.06 [0.13]	0.34 [0.75] 0.87 [1.92]	0.21 [0.46] 0.62 [1.37]
63 [2.480]	1.61 [3.55] (1.69 [3.73])	1.84 [4.06] (1.92 [4.23])	2.13 [4.70] (2.21 [4.87])	2.14 [4.72] (2.22 [4.90])	2.09 [4.61] (2.17 [4.78])	2.79 [6.15] (2.87 [6.33])	2.03 [4.48] (2.11 [4.65])	2.31 [5.09] (2.39 [5.27])	2.81 [6.20] (2.89 [6.37])	0.00515 [0.1136] (0.01285 [0.2833])	0.04 [0.09]	0.06 [0.13]	0.34 [0.75] 0.87 [1.92]	0.21 [0.46] 0.62 [1.37]
80 [3.150]	2.15 [4.74] (2.32 [5.12])	2.53 [5.58] (2.70 [5.95])	3.00 [6.62] (3.17 [6.99])	3.75 [8.27] (3.92 [8.64])	3.07 [6.77] (3.24 [7.14])	3.79 [8.36] (3.96 [8.73])	3.23 [7.12] (3.40 [7.50])	3.31 [7.30] (3.48 [7.67])	4.03 [8.89] (4.20 [9.26])	0.00634 [0.1395] (0.02134 [0.4705])	0.04 [0.09]	0.06 [0.13]	0.87 [1.92] 1.47 [3.24]	0.62 [1.37] 1.24 [2.73]
100 [3.940]	3.22 [7.10] (3.43 [7.56])	3.69 [8.14] (3.90 [8.60])	4.50 [9.92] (4.71 [10.39])	5.44 [12.00] (5.65 [12.46])	4.46 [9.83] (4.67 [10.30])	5.18 [11.42] (5.39 [11.88])	4.61 [10.17] (4.82 [10.63])	4.75 [10.47] (4.96 [10.94])	5.47 [12.06] (5.68 [12.52])	0.01061 [0.2240] (0.02701 [0.5956])	0.04 [0.09]	0.06 [0.13]	1.47 [3.24] 2.14 [4.73]	1.24 [2.73] 1.81 [4.01]

Note: For lead wire length A (1000mm [39in.]). Calculation example: For foot mounting type with bore size of 50mm, and stroke of 100mm, 1.43+(0.00428×100)=1.858kg [4.097lb.]

Dimensions of Foot Mounting Type (mm)

DDV × -1

 Foot mounting bracket only
DDA -1

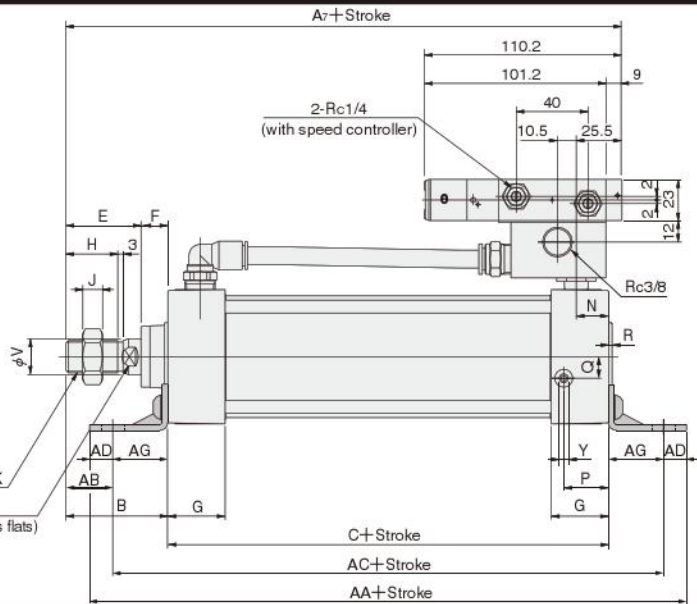
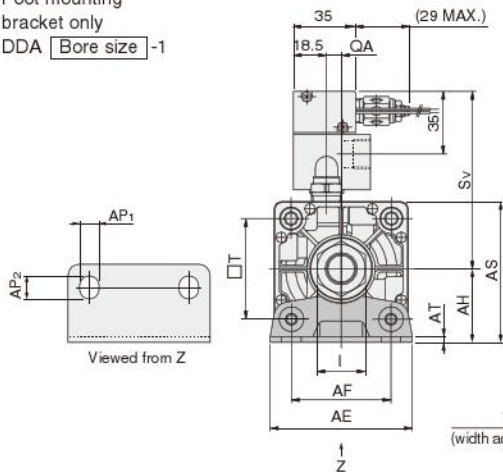

Bore mm [in.]	Code	A7	B	C	E	F	G	H	I	J	K	N	P	Q	QA	R	Sv	T	V	W	Y
40	[1.575]	149.5	49	93	34	15	31	21	22	8	M14×1.5	18	25.5	10	4	2	(86.5)	37	16	14	2.5
50	[1.969]	157.5	57	93	42	15	31	29	27	11	M18×1.5	18	24	12	7	2	(92.5)	47	20	17	3
63	[2.480]	160.5	57	96	42	15	32	29	27	11	M18×1.5	18	25	12	8	2	(99)	56	20	17	3
80	[3.150]	188.5	75	108	54	21	36	37	32	13	M22×1.5	20	29	16	11	2	(108.5)	70	25	21	3
100	[3.940]	188.5	75	108	54	21	36	37	36	14	M26×1.5	20	29	18	12	2	(117.5)	84	30	26	3

Bore mm [in.]	Code	AA	AB	AC	AD	AE	AF	AG	AH	AP1	AP2	AS	AT
40	[1.575]	165	25.5	140	12.5	57	36	23.5	30	11	13	55	3.2
50	[1.969]	173	29	149	12	68	47	28	36.5	11	13	67.5	3.2
63	[2.480]	184	26	158	13	80	56	31	41	11	13	78.5	3.2
80	[3.150]	200	45	168	16	97	70	30	49	14	16	96	4
100	[3.940]	200	45	168	16	112	84	30	57	14	16	113	4

Dimensions of Axial Foot Mounting Type (mm)

DDV × -2

 Axial foot mounting bracket only
DDA -2

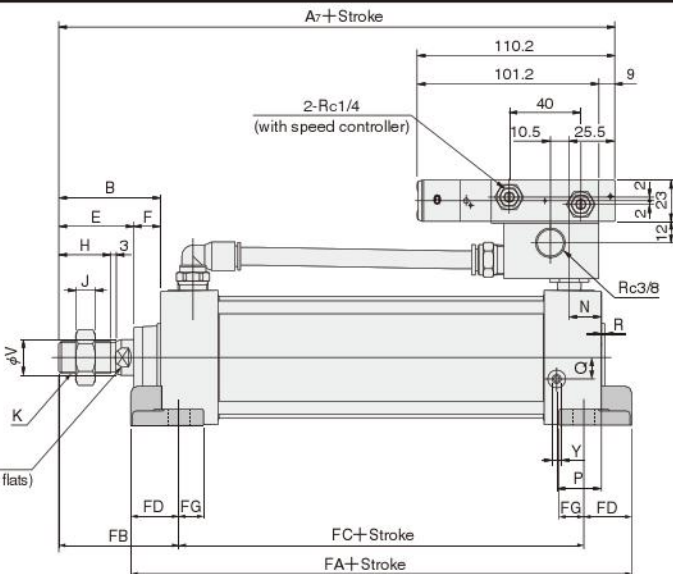
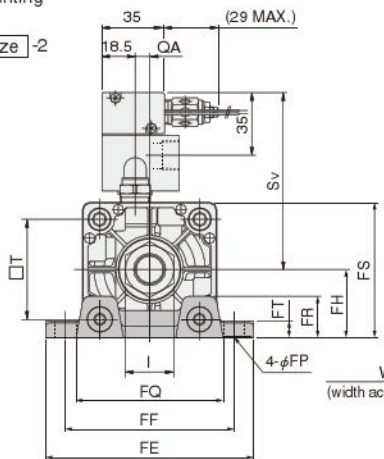

Bore mm [in.]	Code	A7	B	E	F	H	I	J	K	N	P	Q	QA	R	Sv	T	V	W	Y
40	[1.575]	149.5	49	34	15	21	22	8	M14×1.5	18	25.5	10	4	2	(86.5)	37	16	14	2.5
50	[1.969]	157.5	57	42	15	29	27	11	M18×1.5	18	24	12	7	2	(92.5)	47	20	17	3
63	[2.480]	160.5	57	42	15	29	27	11	M18×1.5	18	25	12	8	2	(99)	56	20	17	3
80	[3.150]	188.5	75	54	21	37	32	13	M22×1.5	20	29	16	11	2	(108.5)	70	25	21	3
100	[3.940]	188.5	75	54	21	37	36	14	M26×1.5	20	29	18	12	2	(117.5)	84	30	26	3

Bore mm [in.]	Code	FA	FB	FC	FD	FE	FF	FG	FH	FP	FQ	FR	FS	FT
40	[1.575]	119	59	73	23	92	70	14	25	12	58	16	50	8
50	[1.969]	123	67	73	25	105	83	14	31	12	68	17	62	9
63	[2.480]	130	67	76	27	117	95	14	38	12	84	22	75.5	9
80	[3.150]	150	88	82	34	147	121	18	47	14	104	28	94	13
100	[3.940]	158	88	82	38	168	140	18	57	14	120	30	113	14

Dimensions of Rod Side Flange Mounting Type (mm)

DDV X -3

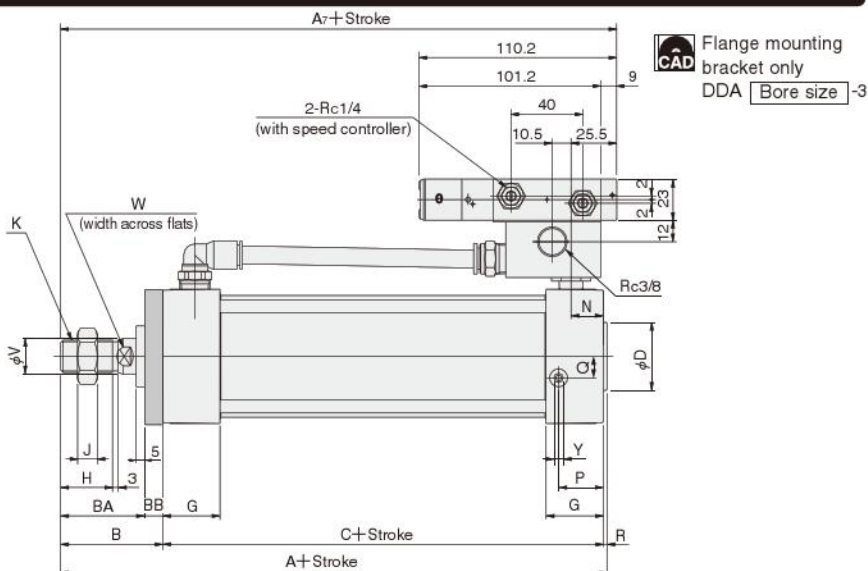
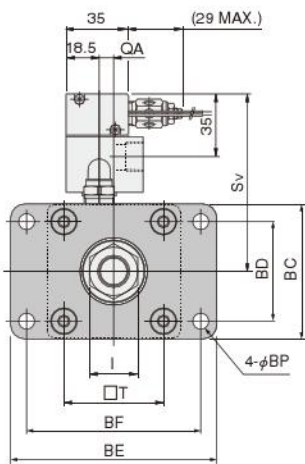

CAD Flange mounting bracket only
DDA -3

Bore mm [in.]	Code	A	A ₇	B	C	D	G	H	I	J	K	N	P	Q	Q _A	R	S _v	T	V	W	Y
40 [1.575]		144	149.5	49	93	32	31	21	22	8	M14×1.5	18	25.5	10	4	2	(86.5)	37	16	14	2.5
50 [1.969]		152	157.5	57	93	38	31	29	27	11	M18×1.5	18	24	12	7	2	(92.5)	47	20	17	3
63 [2.480]		155	160.5	57	96	38	32	29	27	11	M18×1.5	18	25	12	8	2	(99)	56	20	17	3
80 [3.150]		185	188.5	75	108	44	36	37	32	13	M22×1.5	20	29	16	11	2	(108.5)	70	25	21	3
100 [3.940]		185	188.5	75	108	50	36	37	36	14	M26×1.5	20	29	18	12	2	(117.5)	84	30	26	3

Bore mm [in.]	Code	BA	BB	BC	BD	BE	BF	BP
40 [1.575]		39	10	52	36	84	70	7
50 [1.969]		47	10	65	47	104	86	9
63 [2.480]		47	10	76	56	116	98	9
80 [3.150]		59	16	95	70	143	119	12
100 [3.940]		59	16	115	84	162	138	12

Dimensions of Head Side Flange Mounting Type (mm)

DDV X -5

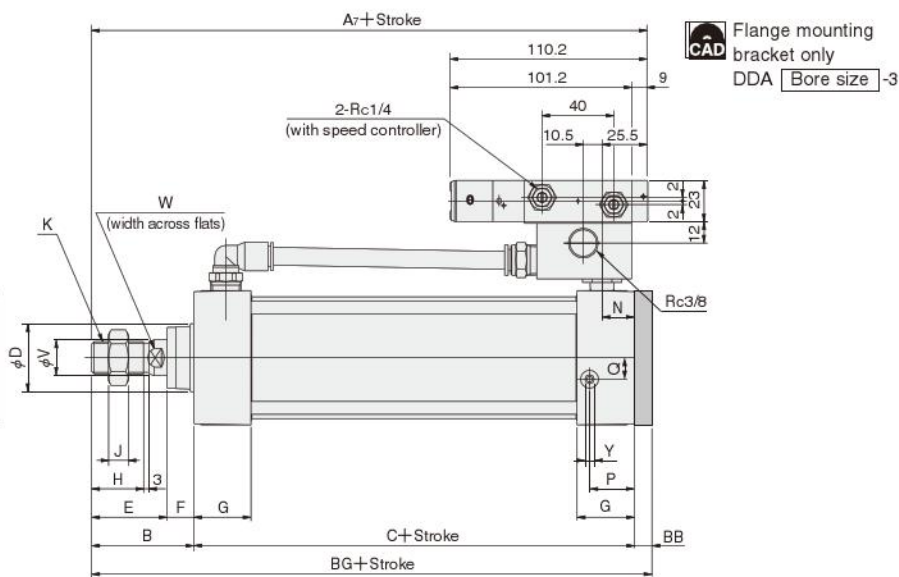
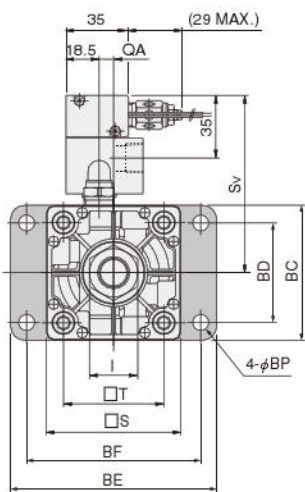

CAD Flange mounting bracket only
DDA -3

Bore mm [in.]	Code	A ₇	B	C	D	E	F	G	H	I	J	K	N	P	Q	Q _A	S	S _v	T	V	W	Y
40 [1.575]		149.5	49	93	32	34	15	31	21	22	8	M14×1.5	18	25.5	10	4	50	(86.5)	37	16	14	2.5
50 [1.969]		157.5	57	93	38	42	15	31	29	27	11	M18×1.5	18	24	12	7	62	(92.5)	47	20	17	3
63 [2.480]		160.5	57	96	38	42	15	32	29	27	11	M18×1.5	18	25	12	8	75	(99)	56	20	17	3
80 [3.150]		188.5	75	108	44	54	21	36	37	32	13	M22×1.5	20	29	16	11	94	(108.5)	70	25	21	3
100 [3.940]		188.5	75	108	50	54	21	36	37	36	14	M26×1.5	20	29	18	12	112	(117.5)	84	30	26	3

Bore mm [in.]	Code	BB	BC	BD	BE	BF	BG	BP
40 [1.575]		10	52	36	84	70	152	7
50 [1.969]		10	65	47	104	86	160	9
63 [2.480]		10	76	56	116	98	163	9
80 [3.150]		16	95	70	143	119	199	12
100 [3.940]		16	115	84	162	138	199	12

Dimensions of Clevis Mounting Type (mm)

DDV X -7

 Clevis mounting bracket only
DDA -7

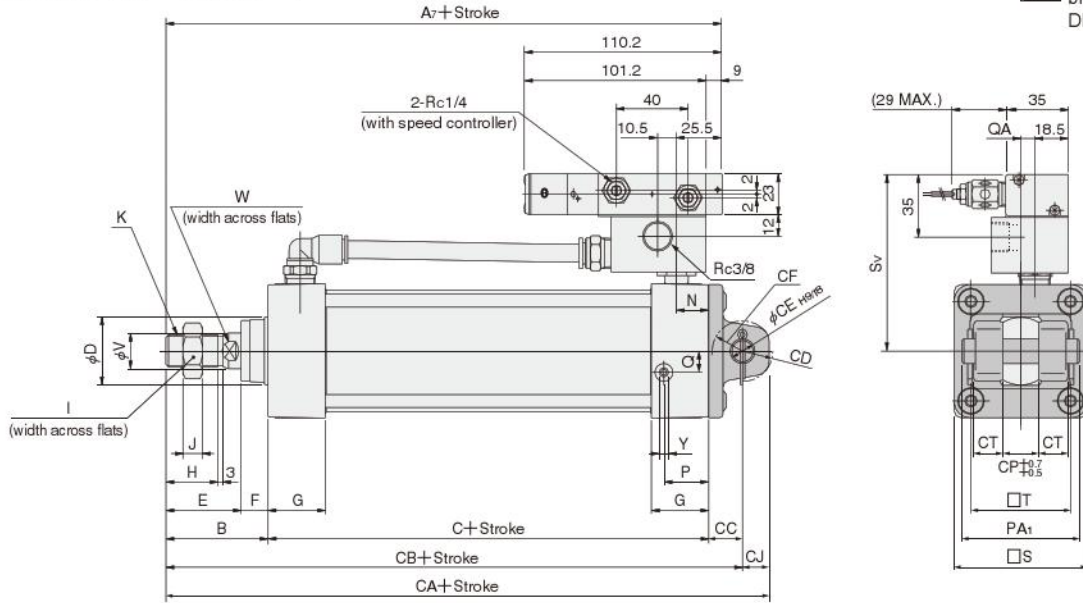

Bore mm [in.]	Code	A7	B	C	D	E	F	G	H	I	J	K	N	P	Q	QA	S	Sv	T	V	W	Y
40	[1.575]	149.5	49	93	32	34	15	31	21	22	8	M14×1.5	18	25.5	10	4	50	(86.5)	37	16	14	2.5
50	[1.969]	157.5	57	93	38	42	15	31	29	27	11	M18×1.5	18	24	12	7	62	(92.5)	47	20	17	3
63	[2.480]	160.5	57	96	38	42	15	32	29	27	11	M18×1.5	18	25	12	8	75	(99)	56	20	17	3
80	[3.150]	188.5	75	108	44	54	21	36	37	32	13	M22×1.5	20	29	16	11	94	(108.5)	70	25	21	3
100	[3.940]	188.5	75	108	50	54	21	36	37	36	14	M26×1.5	20	29	18	12	112	(117.5)	84	30	26	3

Bore mm [in.]	Code	CA	CB	CC	CD	CE	CF	CJ	CP	CT	PA1
40	[1.575]	174	161	19	R15	14	R17	13	20	12.5	58
50	[1.969]	184	169	19	R17	14	R17	15	20	16.5	66
63	[2.480]	187	172	19	R17	14	R17	15	20	16.5	66
80	[3.150]	236	215	32	R24	20	R30	21	32	17.5	78
100	[3.940]	236	215	32	R24	20	R30	21	32	17.5	78

● With Supporting Bracket DDV X -7-7C

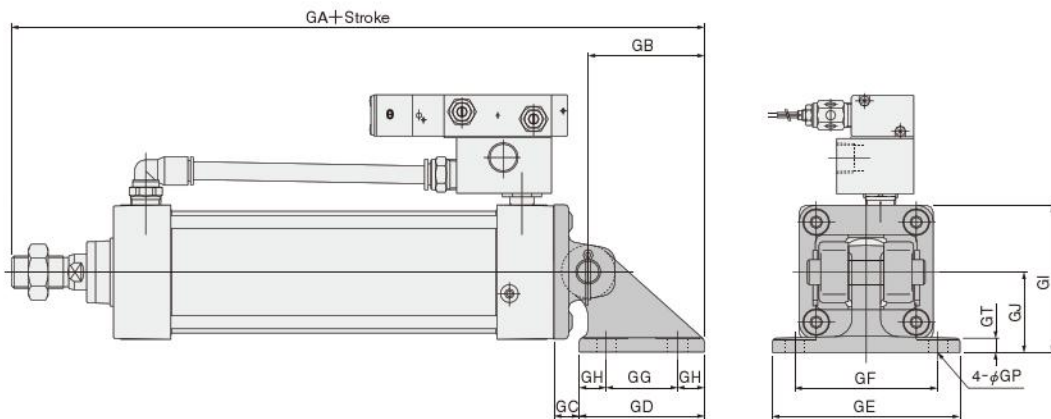

Bore mm [in.]	Code	GA	GB	GC	GD	GE	GF	GG	GH	GI	GJ	GP	GT
40	[1.575]	227.5	66.5	12.5	73	105	80	40	16.5	70	45	11(Thru hole)	8
50	[1.969]	235.5	66.5	12.5	73	105	80	40	16.5	76	45	11(Thru hole)	8
63	[2.480]	238.5	66.5	12.5	73	105	80	40	16.5	82.5	45	11(Thru hole)	8
80	[3.150]	301.5	86.5	20.5	98	135	105	65	16.5	107	60	14(Thru hole)	12
100	[3.940]	301.5	86.5	20.5	98	135	105	65	16.5	116	60	14(Thru hole)	12

Dimensions of Pivot Mounting Type (mm)

DDV X -8

 Pivot mounting bracket only
DDA -8

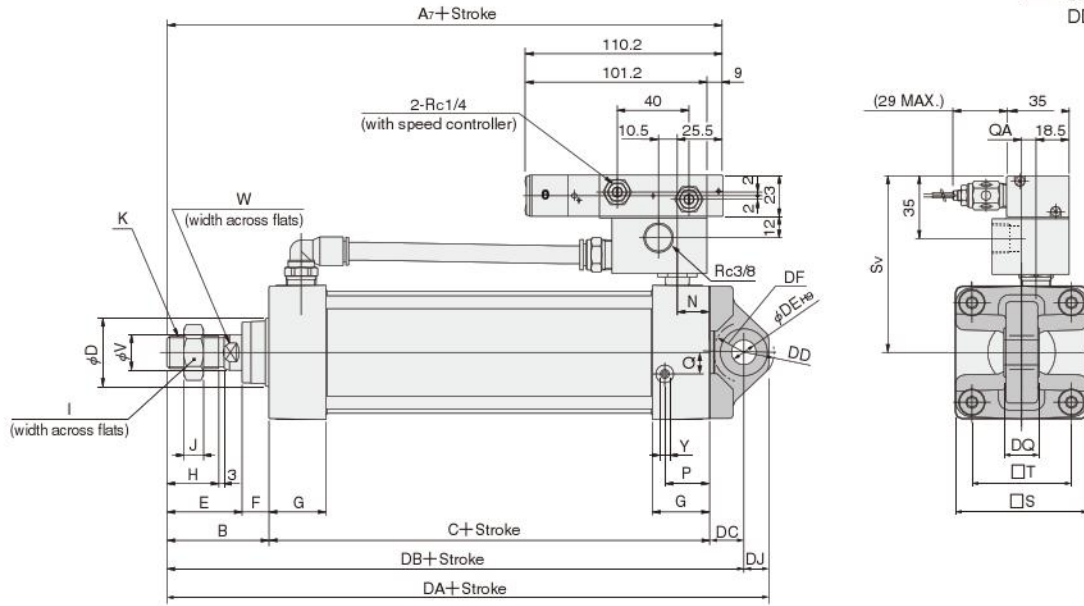

Code	A ₇	B	C	D	E	F	G	H	I	J	K	N	P	Q	Q _A	S	S _v	T	V	W	Y
40 [1.575]	149.5	49	93	32	34	15	31	21	22	8	M14×1.5	18	25.5	10	4	50	(86.5)	37	16	14	2.5
50 [1.969]	157.5	57	93	38	42	15	31	29	27	11	M18×1.5	18	24	12	7	62	(92.5)	47	20	17	3
63 [2.480]	160.5	57	96	38	42	15	32	29	27	11	M18×1.5	18	25	12	8	75	(99)	56	20	17	3
80 [3.150]	188.5	75	108	44	54	21	36	37	32	13	M22×1.5	20	29	16	11	94	(108.5)	70	25	21	3
100 [3.940]	188.5	75	108	50	54	21	36	37	36	14	M26×1.5	20	29	18	12	112	(117.5)	84	30	26	3

Code	DA	DB	DC	DD	DE	DF	DJ	DQ
40 [1.575]	175	161	19	R17	14	R17	14	20 ⁰ _{-0.084}
50 [1.969]	183	169	19	R17	14	R17	14	20 ⁰ _{-0.084}
63 [2.480]	186	172	19	R17	14	R17	14	20 ⁰ _{-0.084}
80 [3.150]	236	215	32	R24	20	R25	21	32 ⁰ _{-0.100}
100 [3.940]	235	215	32	R24	20	R26	20	32 ⁰ _{-0.100}

DYNA CYLINDERS

Dimensions of Trunnion Type (mm)

DDV X -11

Trunnion bracket only
DDA -11

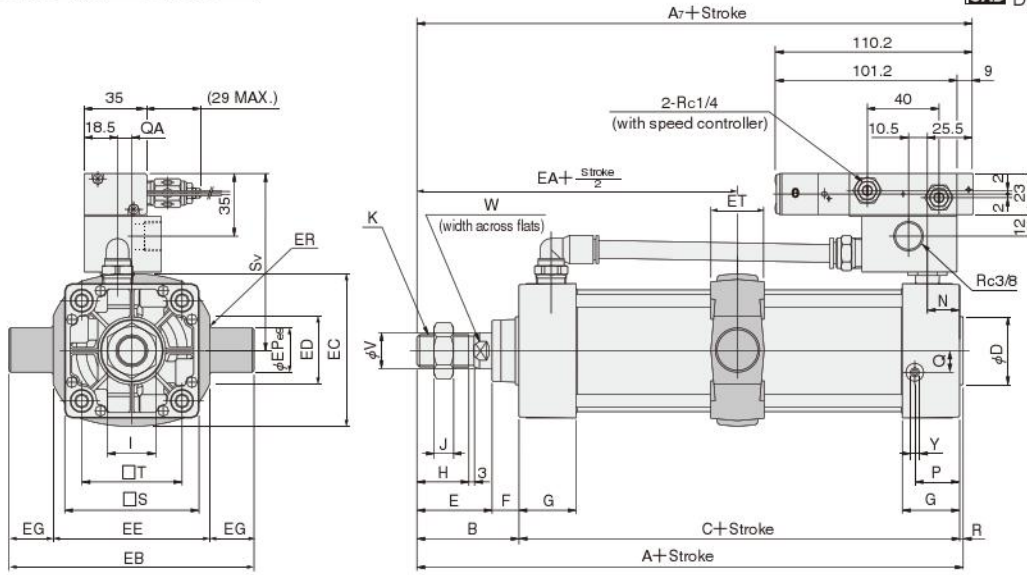

Bore mm (in.)	Code	A	A ₇	B	C	D	E	F	G	H	I	J	K	N	P	Q	Q _A	R	S	S _V	T	V	W	Y
40	[1.575]	144	149.5	49	93	32	34	15	31	21	22	8	M14×1.5	18	25.5	10	4	2	50	(86.5)	37	16	14	2.5
50	[1.969]	152	157.5	57	93	38	42	15	31	29	27	11	M18×1.5	18	24	12	7	2	62	(92.5)	47	20	17	3
63	[2.480]	155	160.5	57	96	38	42	15	32	29	27	11	M18×1.5	18	25	12	8	2	75	(99)	56	20	17	3
80	[3.150]	185	188.5	75	108	44	54	21	36	37	32	13	M22×1.5	20	29	16	11	2	94	(108.5)	70	25	21	3
100	[3.940]	185	188.5	75	108	50	54	21	36	37	36	14	M26×1.5	20	29	18	12	2	112	(117.5)	84	30	26	3

Bore mm (in.)	Code	EA	EB	EC	ED	EE	EG	EP	ER	ET
40	[1.575]	95.5	113	60	30	63	25	25	R1.6	30
50	[1.969]	103.5	126	72	30	76	25	25	R1.6	30
63	[2.480]	105	138	87	40	88	25	25	R1.6	30
80	[3.150]	129	164	105	40	114	25	25	R1.6	35
100	[3.940]	129	182	129	44	132	25	25	R2	40

● With Supporting Brackets DDV X -11-11T

Trunnion supporting bracket only
DDA -11T

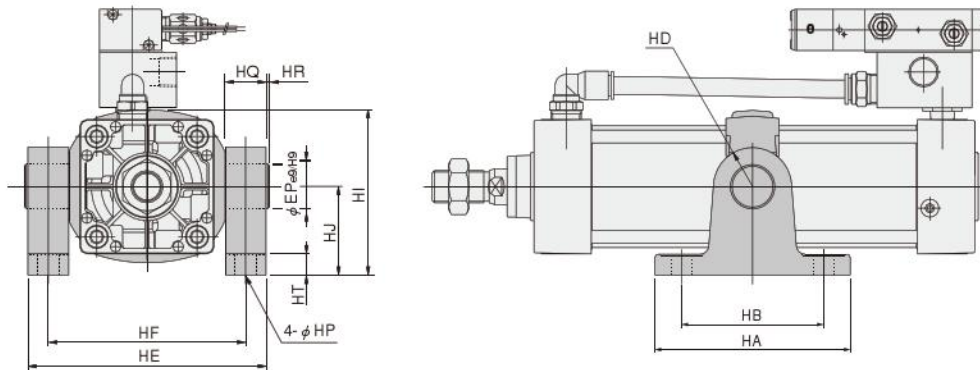

Bore mm (in.)	Code	HA	HB	HD	HE	HF	HI	HJ	HP	HQ	HR	HT	EP
40	[1.575]	111	80	R22	109	86	80	50	12(Thru hole)	23	2	14	25
50	[1.969]	111	80	R22	122	99	86	50	12(Thru hole)	23	2	14	25
63	[2.480]	111	80	R22	134	111	93.5	50	12(Thru hole)	23	2	14	25
80	[3.150]	121	85	R22	160	137	122.5	70	12(Thru hole)	23	2	14	25
100	[3.940]	121	85	R22	178	155	134.5	70	12(Thru hole)	23	2	14	25

SENSOR SWITCHES

Symbol

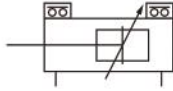

DYNMA CYLINDERS

Order Codes

● Without mounting holder — **ZC130** **A**

● With mounting holder — **ZC130** **A** — **NDDA** **40**

- Sensor switch model**
- ZC130** — 2-lead wire Solid state type with indicator lamp
DC10~28V
 - ZC153** — 3-lead wire Solid state type with indicator lamp
DC4.5~28V
 - CS5T** — 2-lead wire Reed switch type without indicator lamp
DC5~28V, AC85~115V
 - CS11T** — 2-lead wire Reed switch type with indicator lamp
DC10~28V
 - CS2F** — DIN connector Reed switch type with indicator lamp
AC85~230V
 - CS3F** — DIN connector Reed switch type with indicator lamp
DC10~30V
 - CS4F** — DIN connector Reed switch type with indicator lamp
DC10~30V
 - CS5F** — DIN connector Reed switch type without indicator lamp
DC3~30V

NDDA: Applicable to other than **CS□F**
NDF: Applicable to **CS□F** only

Lead wire length
(Applicable to other than **CS□F** only)
A — 1000mm [39in.]
B — 3000mm [118in.]

Bore size

● Order codes for mounting holders only

C1 — **NDDA** **40**

NDDA: Applicable to other than **CS□F**
Blank: For **CS□F**

Sensor type
C1: Solid state type for **ZC1□□**
Reed switch type for **CS□T**
DF: Reed switch type for **CS□F**

Bore size

- 32** — For ϕ 32 [1.260in.]
- 40** — For ϕ 40 [1.575in.]
- 50** — For ϕ 50 [1.969in.]
- 63** — For ϕ 63 [2.480in.]
- 80** — For ϕ 80 [3.150in.]
- 100** — For ϕ 100 [3.940in.]
- 125** — For ϕ 125 [4.921in.]

● For details of sensor switches, see p.1544.

Sensor Switches and Mounting Holders

● DYNMA cylinder sensor switches come in 2 types, and 2 corresponding types of mounting holders are available. See the following for details.

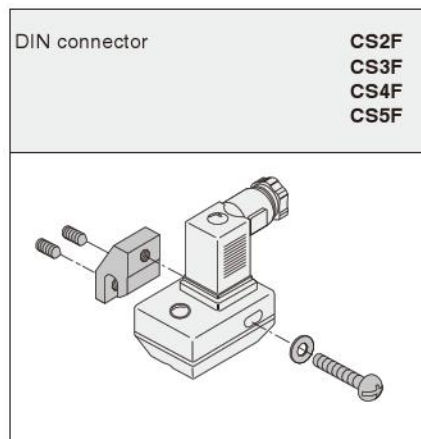
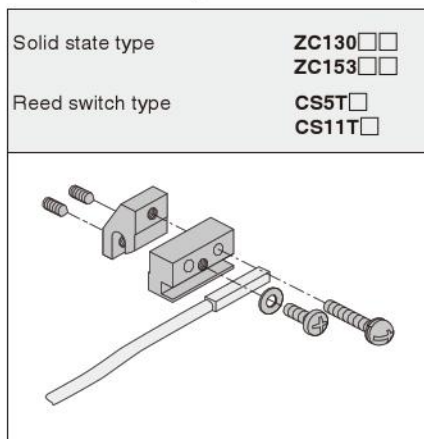

Minimum Cylinder Strokes When Using Sensor Switches

mm

Sensor switch model	Bore size mm [in.]	2pcs. mounting				1pc. mounting		
		Mounting 2 pcs. on a tie rod		Mounting 1 pc. on each tie rod		Rod side	Head side	
		In a straight line	In staggered positions	1-plane mounting	2-plane mounting			
Solid state type	ZC130 ZC153	32 [1.260]	55 (90)	15 (90)	48 (90)	15 (90)	15 (66)	
		40 [1.575]	55 (90)	15 (90)	48 (90)	15 (90)	15 (66)	
		50 [1.969]	55 (90)	15 (90)	15 (90)	15 (90)	15 (66)	
		63 [2.480]	58 (93)	15 (93)	15 (93)	15 (93)	15 (63)	
		80 [3.150]	58 (99)	15 (99)	15 (99)	15 (99)	15 (69)	
		100 [3.940]	58 (99)	15 (99)	15 (99)	15 (99)	15 (69)	
		125 [4.921]	58 (99)	15 (99)	15 (99)	15 (99)	15 (69)	
Reed switch type	CS5T CS11T	32 [1.260]	55 (90)	15 (90)	48 (90)	15 (90)	15 (66)	
		40 [1.575]	55 (90)	15 (90)	48 (90)	15 (90)	15 (66)	
		50 [1.969]	55 (90)	15 (90)	15 (90)	15 (90)	15 (66)	
		63 [2.480]	58 (93)	15 (93)	15 (93)	15 (93)	15 (63)	
		80 [3.150]	58 (99)	15 (99)	15 (99)	15 (99)	15 (69)	
		100 [3.940]	58 (99)	15 (99)	15 (99)	15 (99)	15 (69)	
		125 [4.921]	58 (99)	15 (99)	15 (99)	15 (99)	15 (69)	
	CS□F	32 [1.260]	55 (93)	33 (93)	55 (93)	25 (93)	20 (77)	
		40 [1.575]	55 (93)	33 (93)	55 (93)	25 (93)	20 (77)	
		50 [1.969]	55 (93)	33 (93)	55 (93)	25 (93)	20 (77)	
		63 [2.480]	55 (96)	33 (96)	55 (96)	25 (96)	20 (74)	
		80 [3.150]	55 (101)	33 (101)	25 (101)		20 (101)	20 (79)
		100 [3.940]	55 (99)	33 (106)	25 (106)		20 (106)	20 (84)
		125 [4.921]	55 (99)	33 (106)	25 (106)		20 (106)	20 (84)

Remark: Figures in parentheses () are for trunnion type.

● When mounting 2 sensors on a tie rod

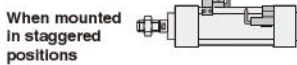

● When mounting 1 sensor on each tie rod



● 1pc. mounting

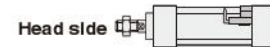

● Mounting on trunnion type



Sensor Switch Operating Range, Response Differential, and Maximum Sensing Location

● ZC1□□ type, CS□T type, CS□F type

● Operating range: ℓ

The distance the piston travels in one direction, while the switch is in the ON position.

● Response differential: C

The distance between the point where the piston turns the switch ON and the point where the switch is turned OFF as the piston travels in the opposite direction.

mm [in.]

Sensor switches model	Solid state type	Reed switch type		
	ZC130, ZC153	CS5T	CS11T	CS□F
Operating range: ℓ	2~6 [0.079~0.236]	6~15 [0.236~0.591]		
Response differential: C	1.5 [0.059] MAX.	2.5 [0.098] MAX.		
Maximum sensing location	8.5 [0.335]	7 [0.276]	10.5 [0.413]	16 [0.630]

Notes: 1. Figures in the grommet type are lengths measured from the switch's opposite end side to the lead wire, while the figures in connector type are lengths measured from the connector side's end surface.

2. The above table shows reference values.

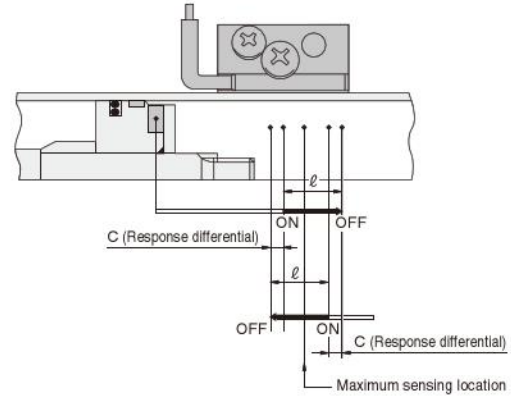

Mounting Location of Sensor Switch

When the sensor switch is mounted in the locations shown in the diagram (figures in the table are reference values), the magnet comes to the sensor switch's maximum sensing location at the end of the stroke.

● Grommet type

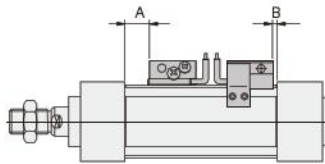

● Connector type

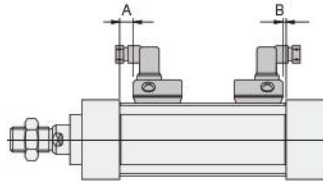

Grommet type enlarged view

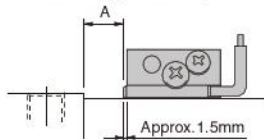

● Precaution for mounting

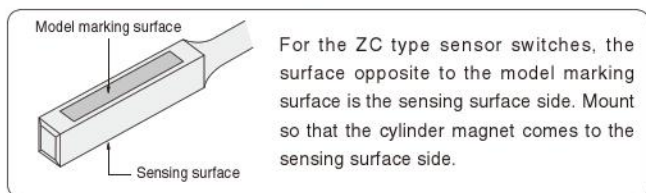

● Single rod basic type and non-rotating double rod type

mm [in.]

Sensor switch model	Bore size Code	32	40	50	63	80	100	125
		Solid state type						
ZC130	A	9 [0.354]	9 [0.354]	9 [0.354]	9.5 [0.374]	12.5 [0.492]	12.5 [0.492]	14.5 [0.571]
	B	5 [0.197]	5 [0.197]	5 [0.197]	5.5 [0.217]	6.5 [0.256]	6.5 [0.256]	10.5 [0.413]
ZC153	A	10.5 [0.413]	10.5 [0.413]	10.5 [0.413]	11 [0.433]	14 [0.551]	14 [0.551]	16 [0.630]
	B	6.5 [0.256]	6.5 [0.256]	6.5 [0.256]	7 [0.276]	8 [0.315]	8 [0.315]	12 [0.472]
Reed switch type								
CS5T	A	7 [0.276]	7 [0.276]	7 [0.276]	7.5 [0.295]	10.5 [0.413]	10.5 [0.413]	12.5 [0.492]
	B	3 [0.118]	3 [0.118]	3 [0.118]	3.5 [0.138]	4.5 [0.177]	4.5 [0.177]	8.5 [0.335]
CS11T	A	7 [0.276]	7 [0.276]	7 [0.276]	7.5 [0.295]	10.5 [0.413]	10.5 [0.413]	12.5 [0.492]
	B	3 [0.118]	3 [0.118]	3 [0.118]	3.5 [0.138]	4.5 [0.177]	4.5 [0.177]	8.5 [0.335]
CS□F	A	3.5 [0.138]	3.5 [0.138]	3.5 [0.138]	4 [0.157]	7 [0.276]	7 [0.276]	9 [0.354]
	B	0	0	0	0	1 [0.039]	1 [0.039]	5 [0.197]

Caution: The reed sensor switch cannot be mounted on the head side in any direction other than that shown in the diagram.

● Standard double rod type

mm [in.]

Sensor switch model	Bore size Code	32	40	50	63	80	100	125
		Solid state type						
ZC130	A	9.5 [0.374]	9 [0.354]	9.5 [0.374]	9.5 [0.374]	12.5 [0.492]	12.5 [0.492]	14.5 [0.571]
	B	4.5 [0.177]	5 [0.197]	4.5 [0.177]	5.5 [0.217]	6.5 [0.256]	6.5 [0.256]	10.5 [0.413]
ZC153	A	11 [0.433]	10.5 [0.413]	11 [0.433]	11 [0.433]	14 [0.551]	14 [0.551]	16 [0.630]
	B	6 [0.236]	6.5 [0.256]	6 [0.236]	7 [0.276]	8 [0.315]	8 [0.315]	12 [0.472]
Reed switch type								
CS5T	A	7.5 [0.295]	7 [0.276]	7.5 [0.295]	7.5 [0.295]	10.5 [0.413]	10.5 [0.413]	12.5 [0.492]
	B	2.5 [0.098]	3 [0.118]	2.5 [0.098]	3.5 [0.138]	4.5 [0.177]	4.5 [0.177]	8.5 [0.335]
CS11T	A	7.5 [0.295]	7 [0.276]	7.5 [0.295]	7.5 [0.295]	10.5 [0.413]	10.5 [0.413]	12.5 [0.492]
	B	2.5 [0.098]	3 [0.118]	2.5 [0.098]	3.5 [0.138]	4.5 [0.177]	4.5 [0.177]	8.5 [0.335]
CS□F	A	4 [0.157]	3.5 [0.138]	4 [0.157]	4 [0.157]	7 [0.276]	7 [0.276]	9 [0.354]
	B	0	0	0	0	1 [0.039]	1 [0.039]	5 [0.197]

Caution: The reed sensor switch cannot be mounted on the head side in any direction other than that shown in the diagram.

Dimensions of Sensor Switch

● ZC130, ZC153, CS□T

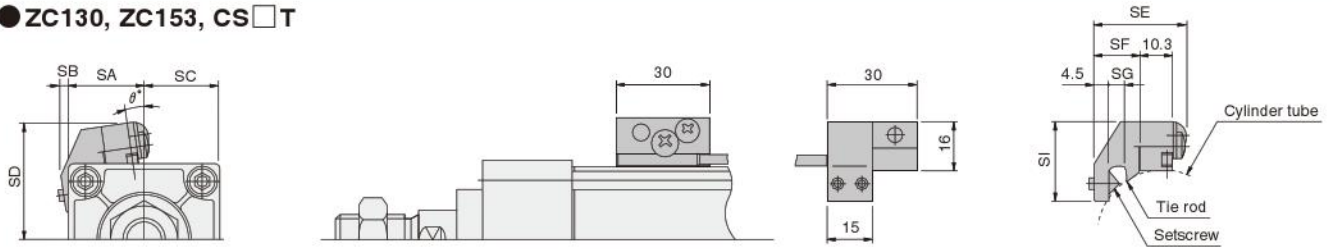

Code mm [in]	SA	SB	SC	SD	SE	SF	SG	SI	θ
32 [1.260]	27	5	17	35	29.8	15.5	6	25.5	1
40 [1.575]	26.1	2	23.9	38.4	29.8	15.5	6	25.5	10
50 [1.969]	27.1	0.7	34.9	43.4	29.8	15.5	6	25.5	10
63 [2.480]	28.3	0	46.7	48.6	31.8	17.5	8	24.5	18
80 [3.150]	30.9	0	63.1	55.9	33.3	19	9.5	22.5	22
100 [3.940]	32.2	0	79.8	63.6	33.3	19	9.5	22.5	24.5
125 [4.921]	36.5	—	99.5	75	37.5	24.8	11	15.5	27.5

● CS□F

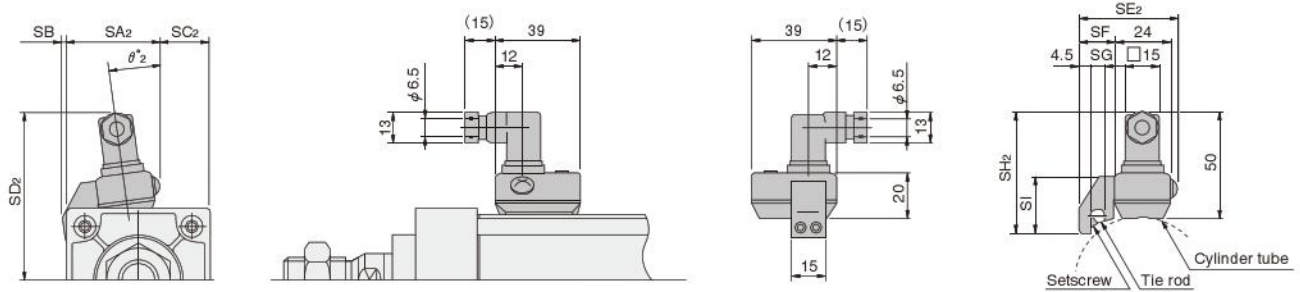

Code mm [in]	SA ₂	SB	SC ₂	SD ₂	SE ₂	SF	SG	SH ₂	SI	θ ₂
32 [1.260]	41.5	5	2.5	66.5	43	15.5	6	56.5	25.5	2.3
40 [1.575]	33.5	1.5	16.5	70	43	15.5	6	56.5	25.5	12
50 [1.969]	40	0.5	22	74.5	43	15.5	6	56.5	25.5	10
63 [2.480]	40.5	0	34.5	79.5	45	17.5	6	55.5	24.5	19
80 [3.150]	42.5	—	51.5	86	46.5	19	9.5	53.5	22.5	23
100 [3.940]	44	—	68	93.5	46.5	19	9.5	53.5	22.5	25
125 [4.921]	49.5	—	86.5	106.5	52.5	25	11	50.5	15.5	23.5

Instructions for Mounting and Moving Sensor Switch

ZC1□□, CS□T types

Requiring parts for mounting 1 sensor switch on a cylinder

- ① Sensor Switch
- ② Washer × 1
- ③ Screw (short) × 1
- ④ Sensor holder × 1
- ⑤ Setscrew × 2
- ⑥ Tie rod
- ⑦ Screw (long) × 1
- ⑧ Sub-holder × 1

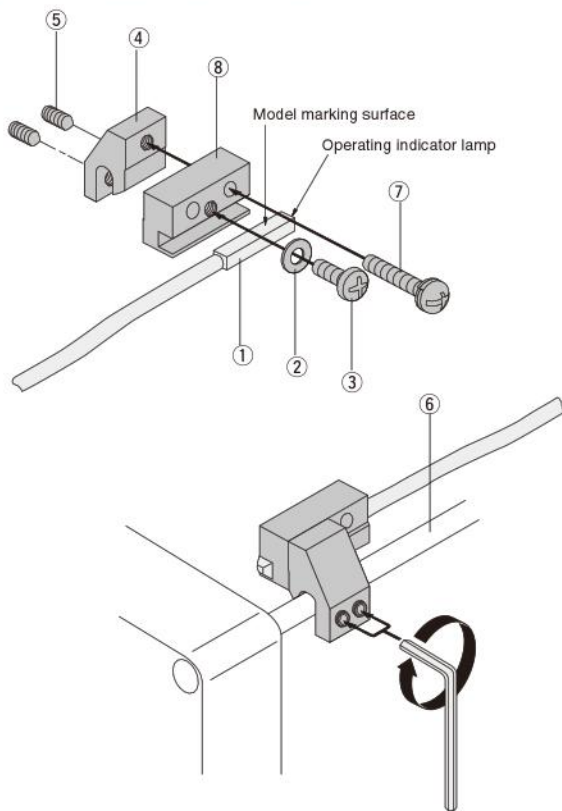

1. ● Align the female thread of sensor holder ④ to the position of the sub-holder ⑧'s thru hole, and use a screw (long) ⑦ to assemble.
 - Two thru holes are available for ⑧. Either one can be used.
 - The appropriate tightening torque for ⑦ is 70 N·cm [6.2in·lbf].
2. ● Install the sensor switch ① with the model marking surface facing upward, and fit it on the groove of ⑧.
 - Align the edges of the body ① and indicator lamp (or the cap) to the end plane of ⑧, and assemble. To protect ①, always assemble so that the body ① does not protrude from the end surface of ⑧.
 - The appropriate tightening torque for the screw (short) ③ is 70N·cm [6.2in·lbf].
3. ● Two setscrews ⑤ are temporarily fixed ④ in place.
 - Fit ④ that was assembled with ① and ⑧ onto the tie rod ⑥, and align it to the designated position. Then use an Allen wrench (width across flats B = 2) to tighten ⑤ and secure it in place. Always secure it so that the bottom surface of ⑧ is in contact with the cylinder tube.
 - The appropriate tightening torque for ⑤ is 70 N·cm [6.2in·lbf].
 - There are four ⑥s on the cylinder, and ④ can be installed on any of them. In addition, ④ can be fitted in any direction.
 - Loosening the 2 screws ⑤ allows ④ to be moved freely along ⑥.

DYNA CYLINDERS

CS□F type

Requiring parts for mounting 1 sensor switch on a cylinder

- ① Sensor Switch
- ② Washer × 1
- ③ Screw × 1
- ④ Sensor holder × 1
- ⑤ Setscrew × 2
- ⑥ Tie rod

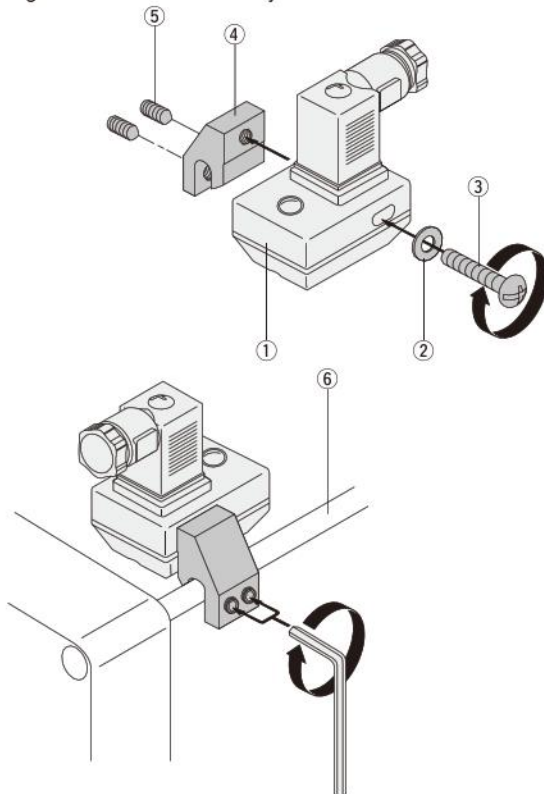

1. ● For the sensor switch ①, align the female thread of sensor holder ④ to any required location of the ①'s thru hole (oval), and assemble.
 - The appropriate tightening torque for the screw ③ is 70N·cm [6.2in·lbf].
2. ● Use 2 setscrews ⑤ to temporarily fix ④ in place.
 - Fit ④ that was assembled with ① onto the tie rod ⑥, and align it to the designated position. Then use an Allen wrench (width across flats B = 2) to tighten ⑤ and secure it in place. Always secure it so that the bottom surface of ① is in contact with the cylinder tube.
 - To detect the head side end of stroke, mount ① so that the connector wiring port faces toward the head cover side, as shown in the diagram to the left.
 - The appropriate tightening torque for ⑤ is 70N·cm [6.2in·lbf].
 - There are four ⑥s on the cylinder, and ④ can be installed on any of them. In addition, ④ can be fitted in any direction.
 - Loosening the 2 screws ⑤ allows ④ to be moved freely along ⑥.

KNUCKLES AND BELLOWS



Dimensions of Knuckle (mm)

● Y type

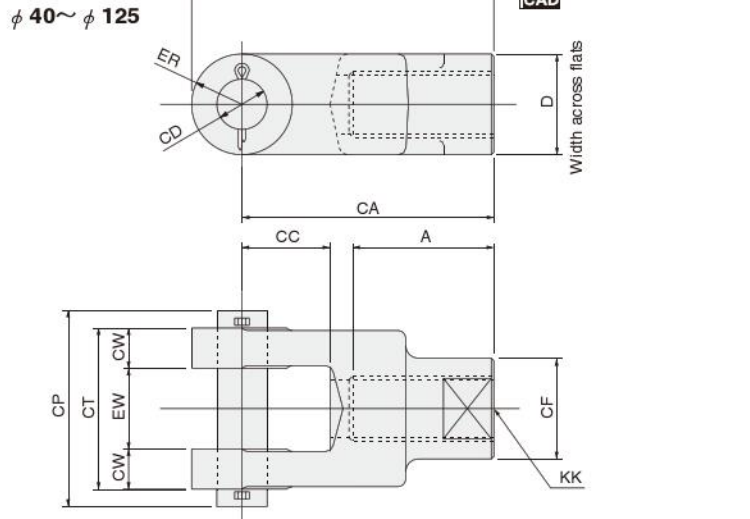
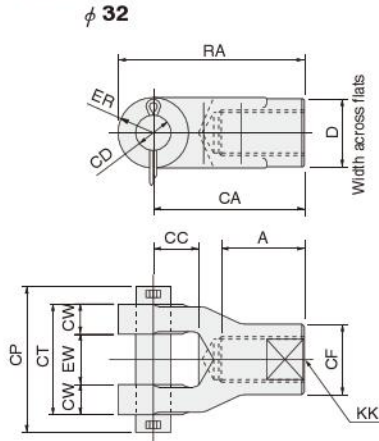

Bore mm [in.]	Code	A	CA	CC	CD	CF	CP	CT	CW	D	ER	EW	KK (other than non-rotating)	KK (non-rotating)	RA
32 [1.260]	23	55	20	$\phi 12_{H9/18}$	$\phi 24$	46	32	32	8	24	R12	$16^{+1.5}_{+0.5}$	M10×1.25	—	67
40 [1.575]	18	46	16	$\phi 12_{H9/18}$	$\phi 25$	48	48	36	9	—	R12.5	$18^{+0.4}_{+0.1}$	M14×1.5	M12×1.25	58.5
50 [1.969]	22	46	16	$\phi 12_{H9/18}$	$\phi 25$	48	48	36	9	—	R12.5	$18^{+0.4}_{+0.1}$	M18×1.5	M18×1.5	58.5
63 [2.480]	22	50	20	$\phi 16_{H9/18}$	$\phi 32$	56	44	44	11	—	R16	$22^{+0.4}_{+0.1}$	M18×1.5	M18×1.5	66
80 [3.150]	30	75	25	$\phi 20_{H9/18}$	$\phi 40$	68	68	56	14	—	R20	$28^{+0.4}_{+0.1}$	M22×1.5	M22×1.5	95
100 [3.940] (other than non-rotating)	34	75	25	$\phi 20_{H9/18}$	$\phi 40$	68	68	56	14	—	R20	$28^{+0.4}_{+0.1}$	M26×1.5	—	95
100 [3.940] (non-rotating)	34	75	25	$\phi 20_{H9/18}$	$\phi 40$	68	68	56	14	—	R20	$28^{+0.4}_{+0.1}$	—	M22×1.5	95
125 [4.921]	56	100	35	$\phi 20_{H9/18}$	$\phi 40$	78	78	64	16	40	R20	$32^{+1.5}_{+0.5}$	M27×2	—	120

● I type

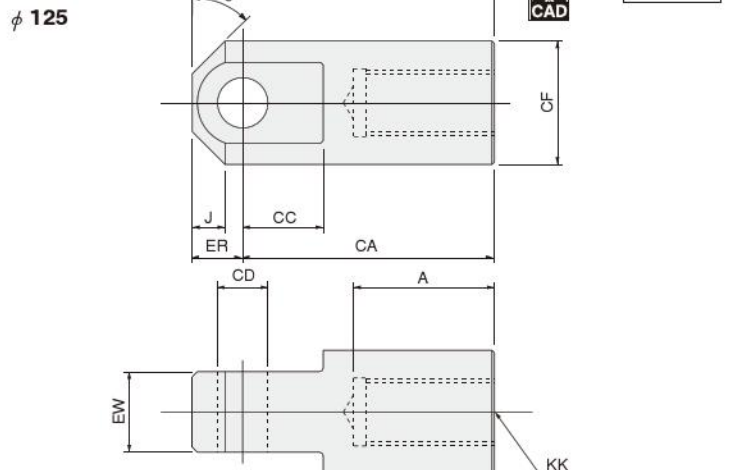
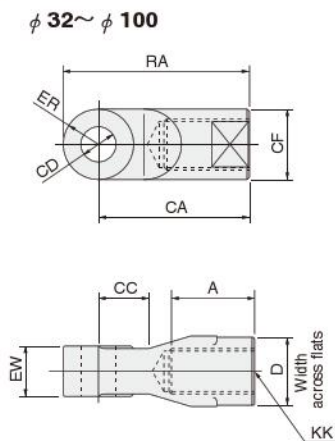

Bore mm [in.]	Code	A	CA	CC	CD	CF	D	ER	EW	J	KK (other than non-rotating)	KK (non-rotating)	RA
32 [1.260]	23	55	20	$\phi 12_{H9}$	$\phi 24$	—	24	R12	$16^{0}_{-0.1}$	—	M10×1.25	—	67
40 [1.575]	18	46	16	$\phi 12_{H9}$	$\phi 25$	—	—	R12.5	$18^{0}_{-0.1}$	—	M14×1.5	M12×1.25	58.5
50 [1.969]	22	46	16	$\phi 12_{H9}$	$\phi 25$	—	—	R12.5	$18^{0}_{-0.1}$	—	M18×1.5	M18×1.5	58.5
63 [2.480]	22	50	20	$\phi 16_{H9}$	$\phi 32$	—	—	R16	$22^{0}_{-0.1}$	—	M18×1.5	M18×1.5	66
80 [3.150]	30	75	25	$\phi 20_{H9}$	$\phi 40$	—	—	R20	$28^{0}_{-0.1}$	—	M22×1.5	M22×1.5	95
100 [3.940] (other than non-rotating)	34	75	25	$\phi 20_{H9}$	$\phi 40$	—	—	R20	$28^{0}_{-0.1}$	—	M26×1.5	—	95
100 [3.940] (non-rotating)	34	75	25	$\phi 20_{H9}$	$\phi 40$	—	—	R20	$28^{0}_{-0.1}$	—	—	M22×1.5	95
125 [4.921]	56	100	32	$\phi 20_{H9}$	$\phi 49$	—	—	20	$32^{0}_{-0.1}$	13	M27×2	—	120

Dimensions of Bellows (mm [In.])

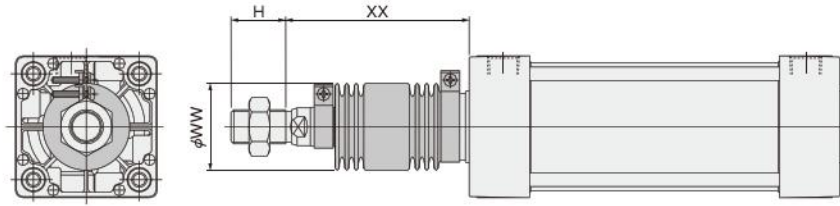

Bore size mm [in.]	Code	WW				XX				H
		Nylon tarpaulin	Chloroprene	Conex	Alumix	Nylon tarpaulin	Chloroprene	Conex	Alumix	
32 [1.260]		36 [1.42]	36 [1.42]	61 [2.40]	36 [1.42]	1/3 stroke + 48 [1.89]	1/3 stroke + 48 [1.89]	1/2 stroke + 48 [1.89]	1/2 stroke + 48 [1.89]	19 [0.75]
40 [1.575]		41 [1.61]	41 [1.61]	61 [2.40]	41 [1.61]					21 [0.83]
50 [1.969]		47 [1.85]	47 [1.85]	61 [2.40]	47 [1.85]	1/3 stroke + 53 [2.09]	1/3 stroke + 53 [2.09]	1/2 stroke + 53 [2.09]	1/2 stroke + 53 [2.09]	29 [1.14]
63 [2.480]		47 [1.85]	47 [1.85]	61 [2.40]	47 [1.85]					29 [1.14]
80 [3.150]		56 [2.20]	56 [2.20]	61 [2.40]	56 [2.20]	1/4 stroke + 58 [2.28]	1/4 stroke + 58 [2.28]	2/5 stroke + 58 [2.28]	2/5 stroke + 58 [2.28]	37 [1.46]
100 [3.940]		61 [2.40]	61 [2.40]	61 [2.40]	61 [2.40]					37 [1.46]
125 [4.921]		71 [2.80]	71 [2.80]	71 [2.80]	71 [2.80]	1/4 stroke + 59 [2.32]	1/4 stroke + 59 [2.32]	2/5 stroke + 59 [2.32]	2/5 stroke + 59 [2.32]	50 [1.97]

● Bellows Specifications

Type	Specifications	Contents	Heat resistant temperature °C [°F]
Nylon tarpaulin (standard)		Coating vinyl to nylon cloth	80 [176]
Chloroprene		Coating chloroprene to nylon cloth	100 [212]
Conex		Coating silicone to Conex cloth (no use of asbestos)	200 [392]
Alumix		Coating aluminum foil to asbestos cloth	250 [482]

Note: The temperatures shown are the bellows' own durable temperatures, and are not temperatures for cylinder use.

Order Codes of Mounting Brackets and Knuckles

● Mounting bracket



Cylinder type

- NDDA — DYNA cylinder
- NDDAR — DYNA cylinder with brake
- NDDAE — DYNA pull side stroke adjusting cylinder
- NDDAP — DYNA push side stroke adjusting cylinder

Mounting bracket

- 1 — Foot mounting type (One set of 2 units)
- 2 — Axial foot mounting type (One set of 2 units)
- 3 — Rod side flange mounting type^{Note}
- 5 — Head side flange mounting type
- 7 — Clevis mounting type (with pin)
- 7-7C — Clevis mounting type (with supporting bracket)
- 8 — Pivot mounting type
- 11 — Trunnion type
- 11-11T — Trunnion type (with supporting brackets)

Note: The rod side flange cannot be retrofitted with the bellows type.

Bore size

- 32 — For φ 32 [1.260in.]
- 40 — For φ 40 [1.575in.]
- 50 — For φ 50 [1.969in.]
- 63 — For φ 63 [2.480in.]
- 80 — For φ 80 [3.150in.]
- 100 — For φ 100 [3.940in.]
- 125 — For φ 125 [4.921in.]

● Y, I type knuckle



Cylinder type

- NDDA — DYNA cylinder
- NDDAL — DYNA non-rotating cylinder

Knuckles

- Y — Y type knuckle
- I — I type knuckle

● For dimensions of knuckle, see p.537.

Bore size

- 32 — For φ 32 [1.260in.]
- 40 — For φ 40 [1.575in.]
- 50 — For φ 50 [1.969in.]
- 63 — For φ 63 [2.480in.]
- 80 — For φ 80 [3.150in.]
- 100 — For φ 100 [3.940in.]
- 125 — For φ 125 [4.921in.]

Maximum Available Stroke of Cylinder with Bellows

Bellows model / Bore size	mm [in.]	
	φ 32 [1.260]~φ 63 [2.480]	φ 80 [3.150]~φ 125 [4.921]
JT	Maximum available St×3/4-50	Maximum available St×4/5-50
JC	Maximum available St×3/4-50	Maximum available St×4/5-50
JK	Maximum available St×2/3-50	Maximum available St×2/3-50
JA	Maximum available St×2/3-50	Maximum available St×2/3-50