

DYNA CYLINDERS

*Ultra-reliable, high-function
tie-rod cylinder*

The DYNA cylinders, compact and lightweight mid-sized actuators compatible with ISO standards, offer a wide range of configurations and mounting types to meet various application requirements in a flexible manner.

Moreover, the use of a new type of cushion needle and floating seal have made these products user-friendlier.

*Light
&
Compact*

Product Line Up

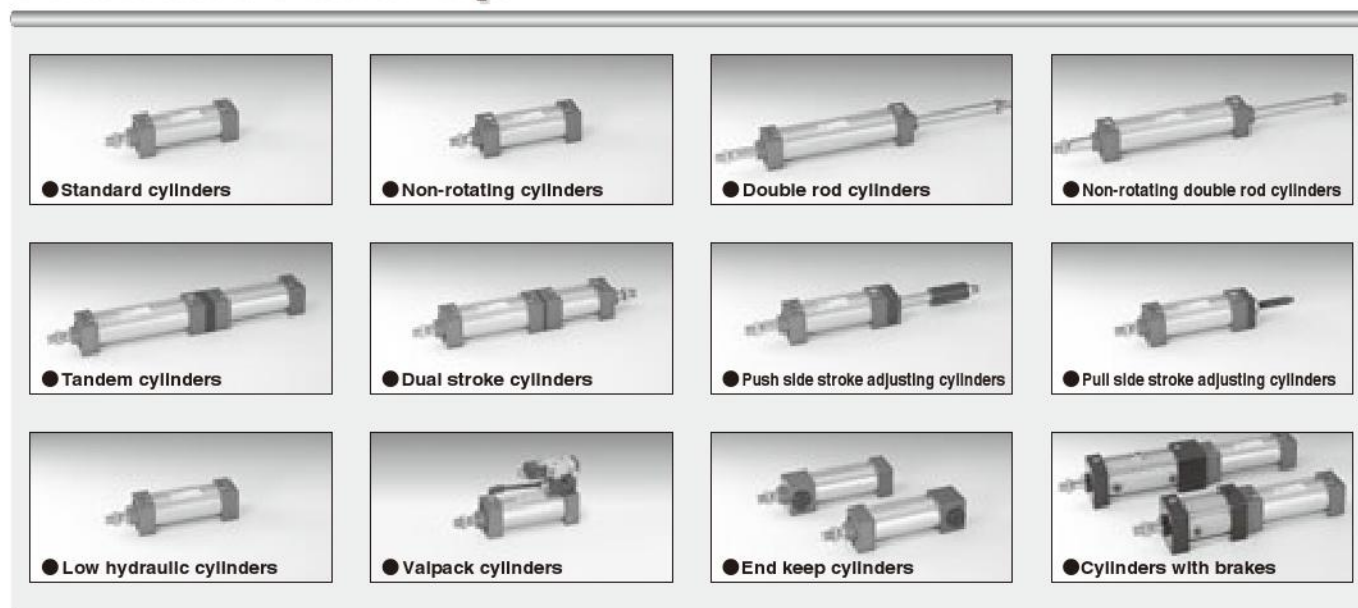

Mounting type

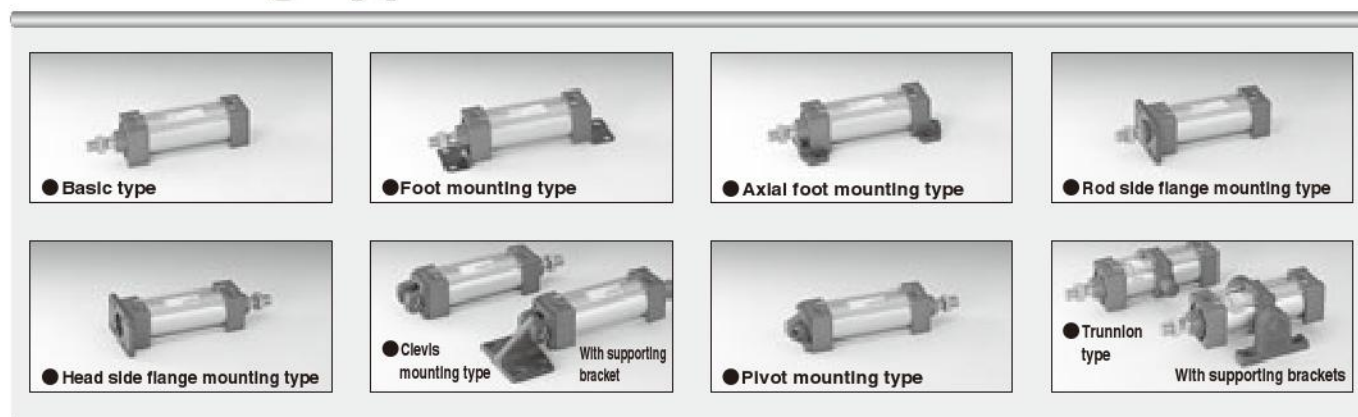

Accessory



design in the smallest standard size for a mid-sized,

1 Extensive variation of functions

■ The series configuration together with its versatile functionality and specifications offers the best match for various mechanical devices.

2 Improved cushioning

■ Improved cushioning is gained by utilizing floating seal in the cushion section.

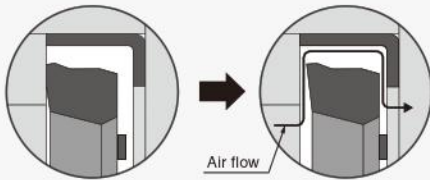

3 Long life

■ Oil impregnated sintered copper alloy in bushings enables stable operation and longer life.

4 New cushion needle

■ Using a new type of cushion needle that is completely embedded in the cylinder body offers fine adjustment for better performance.

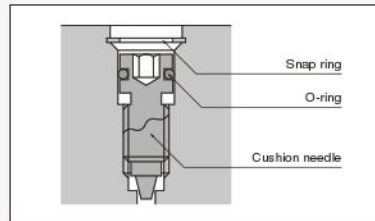

5 Safe self-locking mechanism

■ New release of cylinders with brakes. Exhausting compressed air pushes a brake shoe against the piston rod thereby stopping the cylinder.

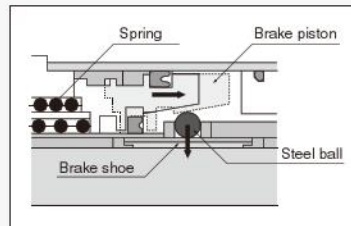

※ Steel balls and a brake shoe are secured in position. Operating the brake piston enables activation or release of the brake.

Series configurations

	Basic type	Foot mounting type	Axial foot mounting type	Rod side flange mounting type	Head side flange mounting type	Ceiling mounting type (with supporting brackets)	Pivot mounting type	Tandem type (with supporting brackets)
Standard cylinder ($\phi 32$ [1.260]~ $\phi 125$ [4.921])	●	●	●	●	●	●	●	●
Non-rotating cylinder ($\phi 40$ [1.575]~ $\phi 100$ [3.940])	●	●	●	●	●	●	●	●
Double rod cylinder ($\phi 32$ [1.260]~ $\phi 125$ [4.921])	●	●	●	●	●	●	●	●
Non-rotating double rod cylinder ($\phi 40$ [1.575]~ $\phi 100$ [3.940])	●	●	●	●	●	●	●	●
Tandem cylinder ($\phi 40$ [1.575]~ $\phi 100$ [3.940])	●	●	●	●	●	●	●	●
Dual stroke cylinder ($\phi 40$ [1.575]~ $\phi 100$ [3.940])	●	●	●	●	●	●	●	●
Push side stroke adjusting cylinder ($\phi 40$ [1.575]~ $\phi 100$ [3.940])	●	●	●	●	●	●	●	●
Pull side stroke adjusting cylinder ($\phi 40$ [1.575]~ $\phi 100$ [3.940])	●	●	●	●	●	●	●	●
Low hydraulic cylinder ($\phi 32$ [1.260]~ $\phi 100$ [3.940])	●	●	●	●	●	●	●	●
Valpack cylinder ($\phi 40$ [1.575]~ $\phi 100$ [3.940])	●	●	●	●	●	●	●	●
End keep cylinder ($\phi 40$ [1.575]~ $\phi 100$ [3.940])	●	●	●	●	●	●	●	●
Cylinder with brake ($\phi 40$ [1.575]~ $\phi 100$ [3.940])	●	●	●	●	●	●	●	●

mm [in.]

Handling Instructions and Precautions



General precautions

Media

1. Use air for the media. For the use of any other media, consult us.
2. Air used for the DYNA cylinder should be clean air that contains no deteriorated compressor oil, water, dust, etc. Install an air filter (filtration of a minimum 40 μm) near the cylinder or valve to remove collected liquid or dust. In addition, drain the air filter periodically.

Piping

Always thoroughly blow off (use compressed air) the tubing before connecting it to the DYNA cylinder. Entering chips, sealing tape, rust, etc., generated during piping work could result in air leaks or other defective operation.

Atmosphere

If using in locations subject to dripping water, dripping oil, etc., or to large amounts of dust, use a cover to protect the unit.

Lubrication

This equipment can be used without lubrication. If lubrication is required, use Turbine Oil Class 1 (ISO VG32) or lithium soap-based grease No.2 or equivalent.



Handling

Assembly of mounting bracket

Use mounting screws which are supplied with the bracket to assemble the mounting bracket. Use an Allen wrench to tighten the mounting screws evenly. When 4 screws are used, tighten diagonally from each corner. The tightening torque is shown below.

Assembly and disassembly

For disassembly, insert an Allen wrench to loosen the tie rod nut, and remove the cover.

For assembly, screw in the tie rod nut with the hexagon socket facing outward. Evenly tighten diagonally from each corner. The tightening torque is shown below.

<Tightening torque of mounting brackets and tie rod nuts>

Bore size mm [in.]	Tightening torque
32, 40, 50 [1.260, 1.575, 1.969]	4.81N·m [3.55ft·lbf]
63 [2.480]	12.0N·m [8.85ft·lbf]
80, 100 [3.150, 3.940]	24.0N·m [17.7ft·lbf]
125 [4.921]	42.2N·m [31.1ft·lbf]

● Width across flats of hexagon socket mm [in.]

Bore size	Tie rod nut	Mounting bracket
32 [1.260]	6 [0.236]	4 [0.157]
40, 50 [1.575, 1.969]	6 [0.236]	4 [0.157]
63 [2.480]	8 [0.315]	5 [0.197]
80, 100 [3.150, 3.940]	10 [0.394]	6 [0.236]
125 [4.921]	12 [0.472]	8 [0.315]

● φ 32 [1.260in.]

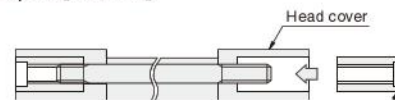

Use hexagon socket tie rod nuts on both sides for only 32φ

● φ 40 [1.575in.]~ φ 125 [4.921in.]

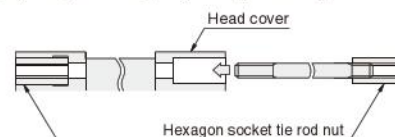

Tie rod nut with knurl



Manual operation of end keep cylinder locking mechanism

While the locking mechanism is normally released automatically through cylinder operations, it can also be released manually. For manual release, insert an M4×0.7 screw that has 30mm [1.18in.] screw length into the manual override opening, thread it in about 3 turns into the internal lock piston, and then pull up the screw. To maintain the manual override for adjustment, etc., thread the locknut onto the screw and, with the locking mechanism in a released state, tighten the locknut against the cylinder.

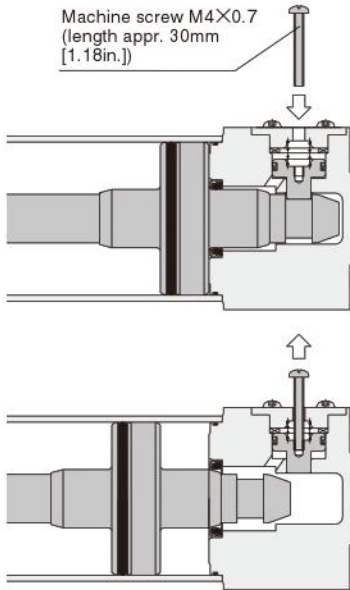

- Cautions:**
1. It is dangerous to release the lock when load (weight) is present on the piston rod, because it may cause the unintended piston rod's extension (or retraction). In this case, always supply air to the connection port opposite the one adjacent to the locking mechanism before releasing the locking mechanism.
 2. If the locking mechanism cannot easily be released even with manual override, it could be the result of galling of the lock piston and piston rod. In this case, supply air to the connection port opposite the one adjacent to the locking mechanism before releasing the locking mechanism.
 3. Because water, oil, dust, etc., intruding through the manual override opening may be a cause of defective locks or other erratic operation. If using in locations subject to dripping water, dripping oil, etc., or large amounts of dust, use a cover to protect the unit.
 4. If the circuit cannot maintain exhaust pressure at 0.03MPa [4.4psi.] or less due to using a manifold valve, use individual valve for operations.

Dedicated muffler

The dedicated muffler can be mounted on the manual override opening.
Dedicated muffler model SA-5 (mm)

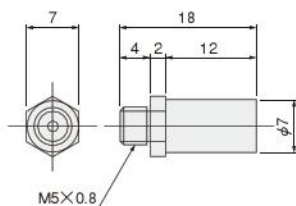

Control circuit for the end keep cylinder

1. For control of the DYNA end keep cylinders, we recommend the use of 2-position, 4-, 5-port valves. Avoid the use of control circuit of ABR connections (exhaust centers) with 3-position valves that exhaust air from 2 ports.
2. Always use meter-out control for speed control. Meter-in control may result in failure of the locking mechanism to release.
3. Always set the air pressure to 0.15MPa [22psi.] or more.

- Cautions:**
1. It is dangerous to supply air to a connection port on a side with a locking mechanism while the cylinder has already been exhausted, because the piston rod may suddenly extend (or retract). In addition, since the lock piston could also cause galling of the lock piston and piston rod, resulting in defective operation. Always supply air to the connection port on the opposite side of the locking mechanism to ensure applying back pressure.
 2. When restarting operations after air has been exhausted from the cylinder due to completion of operations or to an emergency stop, always start by supplying air to a connection port on the opposite side of the locking mechanism.
 3. Connect the valve port A (NC) to the connection port on the side with the locking mechanism.

Handling Instructions and Precautions



Mounting and piping (for cylinder with brake)

Operating principle

The cylinder with brake uses a mechanism that consists of steel balls contacting an incline and it receives components of a spring force, then it transmits the force via a brake shoe to apply to the piston rod.

● When the brake is released

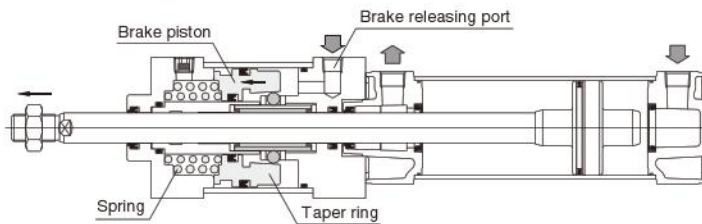

● When the brake is applied

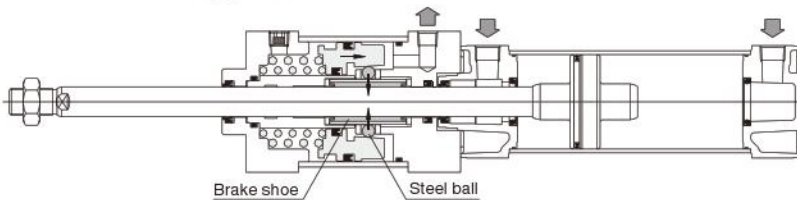

When the brake is released

A supply of compressed air from the brake releasing port causes the brake piston including the taper ring, to retract thereby freeing the steel balls from the taper ring, which releases the brake and lets the piston rod freely slide.

When the brake is applied

Exhausting compressed air from the brake releasing port causes the spring to press against the brake piston, transmitting components of spring force via the taper ring to the steel balls, which then works via the brake shoe to transmit a perpendicular force to the piston rod and to apply friction force to the brake.

Precautions for Installation

1. In the cylinder with brake, the brake piston in the single brake type is secured in place with 2 hexagon socket screws, and in the double brake type with 4 such screws, with the brake set in a released state at shipping.

When piping and installation is completed, or when performing operation checks, first supply at least 0.35MPa [51psi.] (0.4MPa [58psi.] for bore size of $\phi 50$ [1.969in.]) of air to the brake release port, and remove the screws. Then exhausting the compressed air enables the piston rod to be held. While the unit could be operated with the screws removed, it is better for prevention of entering dust to use screws with nuts to secure it in place by inserting 2 or 3 thread ridges into the cylinder.

At this time, do not excessively tighten the screws as they could interfere with the brake piston, by re-locking it in place, or by constricting its movements.

2. Poor centering of the Cylinder with Brake may damage the seal or hasten wear on the brake shoe.

As poor centering could also result in inaccuracy of the stopping position, use of a cylinder joint is recommended.

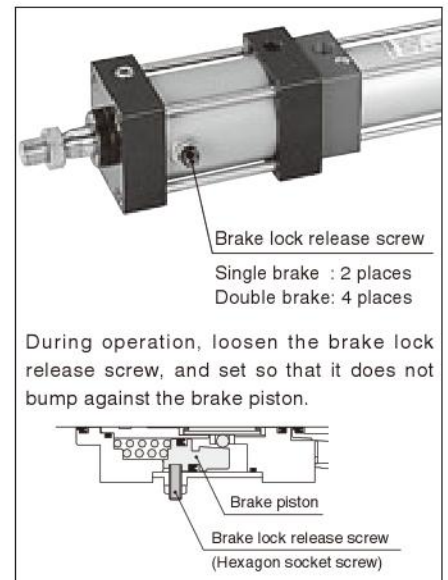

During operation, loosen the brake lock release screw, and set so that it does not bump against the brake piston.



Mounting and piping (for cylinder with brake)

Control circuit

Electric control

When using a sequencer for control, the scanning time of the sequencer will affect the stopping position error. To improve the stopping position accuracy, use a TTL circuit, etc., to directly control the signal from the cylinder's sensor switch, and operate the valve.

Pneumatic circuit

1. To achieve a balance with the load, and a balance of differences in rod diameter area, always use a regulator with check valve.
2. For the cylinder control solenoid valve (V1), use a PAB connection 3-position solenoid valve, etc.
3. Install the solenoid valve for the brake (V2) as close to the cylinder as possible. Moreover, using a DC current solenoid valve will improve response (stopping position accuracy).

Example of basic circuit (Reference)

● Horizontal mounting Spring lock

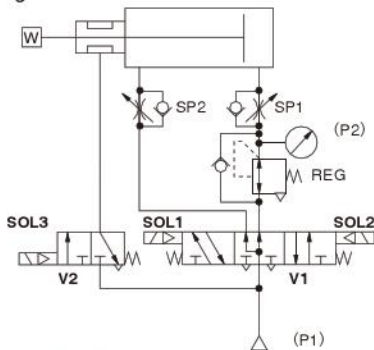

Regulator pressure setting

$$P2 = \frac{D^2 - d^2}{D^2} \cdot P1$$

D : Cylinder bore size (mm)
d : Rod diameter (mm)
P1 : Supply pressure (MPa)

Regulator pressure setting

$$P2' = \frac{D'^2 - d'^2}{D'^2} \cdot P1'$$

D' : Cylinder bore size [in.]
d' : Rod diameter [in.]
P1' : Supply pressure [psi.]

● Vertical mounting Spring lock

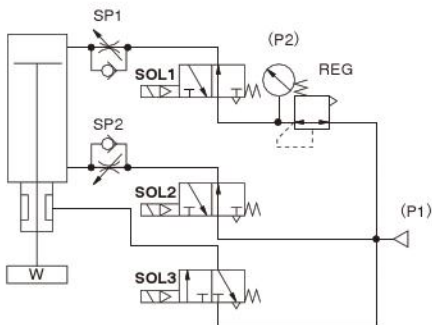

Regulator pressure setting

$$P2 = \frac{\pi (D^2 - d^2) P1 - 4W}{\pi \cdot D^2}$$

D : Cylinder bore size (mm)
d : Rod diameter (mm)
P1 : Supply pressure (MPa)
W : Load (N)

Regulator pressure setting

$$P2' = \frac{\pi (D'^2 - d'^2) P1' - 4W'}{\pi \cdot D'^2}$$

D' : Cylinder bore size [in.]
d' : Rod diameter [in.]
P1' : Supply pressure [psi.]
W' : Load [lbf]

● Vertical mounting (push up)

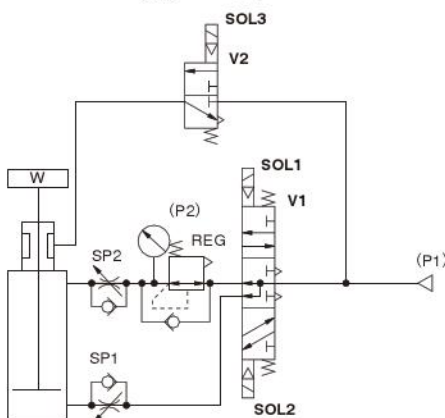

Regulator pressure setting

$$P2 = \frac{\pi \cdot D^2 \cdot P1 - 4W}{\pi (D^2 - d^2)}$$

D : Cylinder bore size (mm)
d : Rod diameter (mm)
P1 : Supply pressure (MPa)
W : Load (N)

Regulator pressure setting

$$P2' = \frac{\pi \cdot D'^2 \cdot P1' - 4W'}{\pi (D'^2 - d'^2)}$$

D' : Cylinder bore size [in.]
d' : Rod diameter [in.]
P1' : Supply pressure [psi.]
W' : Load [lbf]

ON, OFF switch sequence for solenoid (same for all mounting positions)

Valve	V1			V2
	SOL1	SOL2	SOL3	
Operating state	ON	OFF	OFF	OFF
Intermediate stop	OFF	OFF	OFF	OFF
Forward	OFF	ON	ON	ON
Reverse	ON	OFF	ON	ON

Air Flow Rate and Air Consumption

While the air cylinder's air flow rate and air consumption can be found through the following calculations, the quick reference chart to the right provides the answers more conveniently.

$$\text{Air flow rate } Q_1 = \frac{\pi D^2}{4} \times L \times \frac{60}{t} \times \frac{P+0.1013}{0.1013} \times 10^{-6}$$

$$\text{Air consumption } Q_2 = \frac{\pi D^2}{4} \times L \times 2 \times n \times \frac{P+0.1013}{0.1013} \times 10^{-6}$$

- Q₁ : Required air flow rate for cylinder ℓ /min(ANR)
- Q₂ : Air consumption of cylinder ℓ /min(ANR)
- D : Cylinder tube inner diameter mm
- L : Cylinder stroke mm
- t : Time required for cylinder to travel 1 stroke s
- n : Number of cylinder reciprocations per minute times/min
- P : Pressure MPa

$$\text{Air flow rate } Q_1' = \frac{\pi D'^2}{4} \times L' \times \frac{60}{t} \times \frac{P'+14.696}{14.696} \times \frac{1}{1728}$$

$$\text{Air consumption } Q_2' = \frac{\pi D'^2}{4} \times L' \times 2 \times n \times \frac{P'+14.696}{14.696} \times \frac{1}{1728}$$

- Q₁' : Required air flow rate for cylinder ft.³/min.(ANR)**
- Q₂' : Air consumption of cylinder ft.³/min.(ANR)**
- D' : Cylinder tube inner diameter in.
- L' : Cylinder stroke in.
- t : Time required for cylinder to travel 1 stroke sec.
- n : Number of cylinder reciprocations per minute times/min
- P' : Pressure psi.

* Refer to p.54 for an explanation of ANR.

Air consumption for each 1mm [0.0394in.] stroke cm³ [in.³]/Reciprocation (ANR)

Bore size mm [in.]	Air pressure MPa [psi.]								
	0.1 [15]	0.2 [29]	0.3 [44]	0.4 [58]	0.5 [73]	0.6 [87]	0.7 [102]	0.8 [116]	0.9 [131]
32 [1.260]	3.20 [0.1953]	4.78 [0.2917]	6.37 [0.3887]	7.96 [0.4858]	9.55 [0.5828]	11.14 [0.6798]	12.72 [0.7762]	14.31 [0.8733]	15.90 [0.9703]
40 [1.575]	4.99 [0.3045]	7.48 [0.4565]	9.96 [0.6078]	12.44 [0.7591]	14.92 [0.9105]	17.40 [1.0618]	19.88 [1.2132]	22.36 [1.3645]	24.84 [1.5158]
50 [1.969]	7.80 [0.4760]	11.68 [0.7128]	15.56 [0.9495]	19.43 [1.1857]	23.31 [1.4225]	27.19 [1.6592]	31.06 [1.8954]	34.93 [2.1316]	38.78 [2.3685]
63 [2.480]	12.39 [0.7561]	18.54 [1.1314]	24.70 [1.5073]	30.85 [1.8826]	37.01 [2.2585]	43.16 [2.6338]	49.32 [3.0097]	55.46 [3.3844]	61.57 [3.7572]
80 [3.150]	19.98 [1.2193]	29.90 [1.8246]	39.83 [2.4306]	49.75 [3.0359]	59.67 [3.6413]	69.60 [4.2473]	79.52 [4.8526]	89.45 [5.4586]	99.37 [6.0640]
100 [3.940]	31.21 [1.9046]	46.72 [2.8510]	62.23 [3.7975]	77.73 [4.7434]	93.24 [5.6899]	108.75 [6.6364]	124.25 [7.5822]	139.76 [8.5287]	155.27 [9.4752]
125 [4.921]	48.77 [2.9761]	73.00 [4.4548]	97.23 [5.9334]	121.46 [7.4120]	145.69 [8.8906]	169.92 [10.369]	194.14 [11.847]	218.37 [13.326]	242.60 [14.804]

The figures in the table show the air flow rate and air consumption when an air cylinder makes 1 reciprocation with stroke of 1mm [0.0394in.]. The air flow rate and consumption actually required is found by the following calculations.

- Finding the air flow rate (for selecting F.R.L., valves, etc.)
Example: When operating an air cylinder with bore size of 40mm [1.575in.] at speed of 300mm/s [11.8in./sec.], and under air pressure of 0.5MPa [73psi.]

$$14.92 \times \frac{1}{2} \times 300 \times 10^{-3} \div 2.24 \ell / s [0.0791 \text{ft.}^3/\text{sec.}] \text{ (ANR)}$$

(At this time, the air flow rate per minute is $14.92 \times \frac{1}{2} \times 300 \times 60 \times 10^{-3} = 134.28 \ell / \text{min} [4.74 \text{ft.}^3/\text{min.}]$ (ANR).)

- Finding the air consumption
Example 1. When operating an air cylinder with bore size of 40mm [1.575in.] and stroke of 100mm [3.94in.], and under air pressure of 0.5MPa [73psi.], for 1 reciprocation

$$14.92 \times 100 \times 10^{-3} = 1.492 \ell [0.0527 \text{ft.}^3]/\text{Reciprocation (ANR)}$$

- Example 2. When operating an air cylinder with bore size of 40mm [1.575in.] and stroke of 100mm [3.94in.], and under air pressure of 0.5MPa [73psi.], for 10 reciprocations per minute

$$14.92 \times 100 \times 10 \times 10^{-3} = 14.92 \ell / \text{min} [0.527 \text{ft.}^3/\text{min.}] \text{ (ANR)}$$

Cylinder Thrust

Select a suitable cylinder bore size considering the load and air pressure to obtain the required thrust.

Since the figures in the table are calculated values, select a bore size that results in a load ratio (load ratio = $\frac{\text{Load}}{\text{Calculated value}}$) of 70% or less (50% or less for high speed application).

Bore size mm [in.]	Rod diameter mm [in.]	Operation	Pressure area mm ² [in. ²]	Air pressure MPa [psi.]										
				0.1 [15]	0.2 [29]	0.3 [44]	0.4 [58]	0.5 [73]	0.6 [87]	0.7 [102]	0.8 [116]	0.9 [131]	1 [145]	
32 [1.260]	12 [0.472]	Push side	804 [1.246]	80 [18.0]	161 [36.2]	241 [54.2]	322 [72.4]	402 [90.4]	482 [108]	563 [127]	643 [145]	724 [163]	804 [181]	
		Pull side	690 [1.070]	69 [15.5]	138 [31.0]	207 [46.5]	276 [62.0]	345 [77.6]	414 [93.1]	483 [109]	552 [124]	621 [140]	690 [155]	
40 [1.575]	16 [0.630]	Push side	1256 [1.947]	126 [28.3]	251 [56.4]	377 [84.7]	502 [113]	628 [141]	754 [169]	879 [198]	1005 [226]	1130 [254]	1256 [282]	
		Pull side	1055 [1.635]	106 [23.8]	211 [47.4]	317 [71.3]	422 [94.9]	528 [119]	633 [142]	739 [166]	844 [190]	950 [214]	1055 [237]	
50 [1.969]	20 [0.787]	Push side	1963 [3.043]	196 [44.1]	393 [88.3]	589 [132]	785 [176]	982 [221]	1178 [265]	1374 [309]	1570 [353]	1767 [397]	1963 [441]	
		Pull side	1649 [2.556]	165 [37.1]	330 [74.2]	495 [111]	660 [148]	825 [185]	989 [222]	1154 [259]	1319 [297]	1484 [334]	1649 [371]	
63 [2.480]	20 [0.787]	Push side	3117 [4.831]	312 [70.1]	623 [140]	935 [210]	1247 [280]	1559 [350]	1870 [420]	2182 [491]	2494 [561]	2805 [631]	3117 [701]	
		Pull side	2803 [4.345]	280 [62.9]	561 [126]	841 [189]	1121 [252]	1402 [315]	1682 [378]	1962 [380]	2242 [504]	2523 [567]	2803 [630]	
80 [3.150]	25 [0.984]	Push side	5026 [7.790]	503 [113]	1005 [226]	1508 [339]	2010 [452]	2513 [565]	3016 [678]	3518 [791]	4021 [904]	4523 [1017]	5026 [1130]	
		Pull side	4536 [7.031]	454 [102]	907 [204]	1361 [306]	1814 [408]	2268 [510]	2722 [612]	3175 [714]	3629 [816]	4082 [918]	4536 [1020]	
100 [3.940]	30 [1.181]	Push side	7853 [12.17]	785 [176]	1571 [353]	2356 [530]	3141 [706]	3927 [883]	4712 [1059]	5497 [1236]	6282 [1412]	7068 [1589]	7853 [1765]	
		Pull side	7147 [11.08]	715 [161]	1429 [321]	2144 [482]	2859 [643]	3574 [803]	4288 [964]	5003 [1125]	5718 [1285]	6432 [1446]	7147 [1607]	
125 [4.921]	35 [1.378]	Push side	12271 [19.02]	1227 [276]	2454 [552]	3681 [827]	4908 [1103]	6136 [1379]	7363 [1655]	8590 [1931]	9817 [2207]	11044 [2483]	12271 [2759]	
		Pull side	11310 [17.53]	1131 [254]	2262 [508]	3393 [763]	4524 [1017]	5655 [1251]	6786 [1525]	7917 [1780]	9048 [2034]	10179 [2288]	11310 [2542]	

Inner Construction and Major Parts

● Push side stroke adjusting type

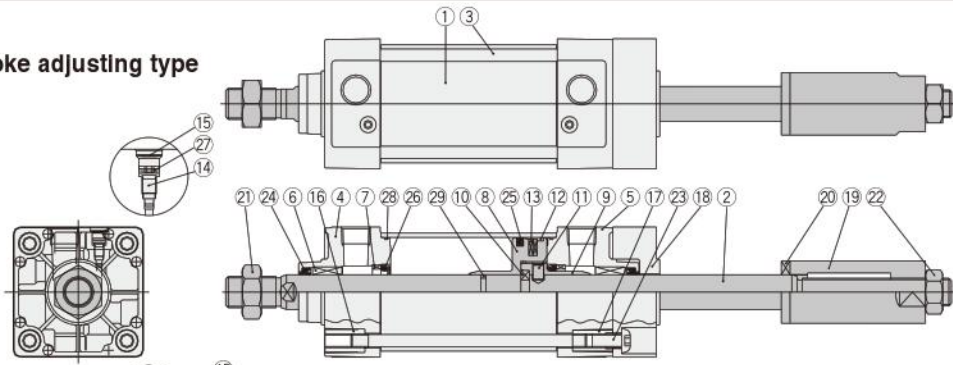

● Pull side stroke adjusting type

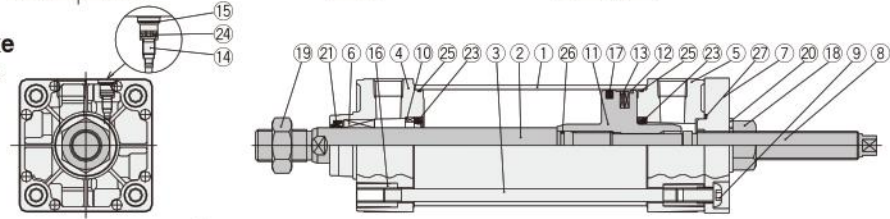

● Instructions for stroke adjustment

Stroke adjusting is performed by rotating the adjusting stopper (push side 19) or stroke adjusting screw (pull side 8). After completing stroke adjustment, secure the adjusting stopper or adjusting screw in place with a lock nut. If mounting a sensor switch, move the mounting location of the sensor switch along the length of the adjusted stroke.

Major Parts and Materials

● Push side stroke adjusting type

No.	Parts	Materials
①	Cylinder tube	Aluminum alloy
②	Piston rod	Carbon steel for machine structural use
③	Tie rod	Carbon steel for machine structural use
④	Rod cover	Aluminum die-casting
⑤	Rod cover	Aluminum die-casting
⑥	Rod bushing	Oil impregnated sintered copper alloy
⑦	Keep ring	Aluminum alloy
⑧	Piston	Aluminum alloy
⑨	Piston	Aluminum alloy
⑩	Split ring	Carbon steel for machine structural use
⑪	(Detent) pin	Carbon steel for machine structural use
⑫	Wear ring	Plastic
⑬	Magnet	Rubber magnet
⑭	Cushion needle	Carbon steel for machine structural use
⑮	Snap ring	Spring steel
⑯	Tie rod nut R	Rolled steel for general structural use
⑰	Tie rod nut H	Chrome-molybdenum steel
⑱	Stopper plate	Carbon steel for machine structural use
⑲	Adjusting stopper	Carbon steel for machine structural use
⑳	Rubber bumper	Urethane rubber
㉑	Rod end nut	Rolled steel for general structural use
㉒	Lock nut	Rolled steel for general structural use
㉓	Button bolt	Chrome-molybdenum steel
㉔	Rod seal	Synthetic rubber (NBR)
㉕	Piston seal	Synthetic rubber (NBR)
㉖	Cushion seal	Synthetic rubber (NBR)
㉗	Cushion gasket	Synthetic rubber (NBR)
㉘	Tube gasket	Synthetic rubber (NBR)
㉙	Piston gasket	Synthetic rubber (NBR)

● Pull side stroke adjusting type

No.	Parts	Materials
①	Cylinder tube	Aluminum alloy
②	Piston rod	Carbon steel for machine structural use
③	Tie rod	Carbon steel for machine structural use
④	Rod cover	Aluminum die-casting
⑤	Head cover	Aluminum die-casting
⑥	Rod bushing	Oil impregnated sintered copper alloy
⑦	Housing	Carbon steel for machine structural use
⑧	Adjusting screw	Carbon steel for machine structural use
⑨	Button bolt	Chrome-molybdenum steel
⑩	Keep ring	Aluminum alloy
⑪	Piston	Aluminum alloy
⑫	Wear ring	Plastic
⑬	Magnet	Rubber magnet
⑭	Cushion needle	Carbon steel for machine structural use
⑮	Snap ring	Spring steel
⑯	Tie rod nut R	Rolled steel for general structural use
⑰	Tie rod nut H	Chrome-molybdenum steel
⑱	Lock nut	Rolled steel for general structural use
⑲	Rod end nut	Rolled steel for general structural use
⑳	Seal washer	Nitrile rubber with metal ring
㉑	Rod seal	Synthetic rubber (NBR)
㉒	Piston seal	Synthetic rubber (NBR)
㉓	Cushion seal	Synthetic rubber (NBR)
㉔	Cushion gasket	Synthetic rubber (NBR)
㉕	Tube gasket	Synthetic rubber (NBR)
㉖	Piston gasket	Synthetic rubber (NBR)
㉗	Housing gasket	Synthetic rubber (NBR)

Seals

● Push side stroke adjusting type

Parts	Rod seal	Piston seal	Cushion seal	Tube gasket	Cushion gasket	Piston gasket
Quantity	2★	1★	2	2★	2	1
Bore mm						
40	DRP16	PWP40N	CPF20	1.5×40	S5	P12
50	DRP20	PWP50N	CPF24	1.5×50	S6	P16
63	DRP20	PWP63N	CPF24	1.5×63	S6	P16
80	DRP25	PWP80N	CPF30	1.5×80	S6	P21
100	DRP30	PWP100N	CPF35	1.5×100	S6	P25

● Pull side stroke adjusting type

Parts	Rod seal	Piston seal	Cushion seal	Tube gasket	Cushion gasket	Piston gasket	Housing gasket	Seal washer
Quantity	1	1	2	2	2	1	1	1
Bore mm								
40	DRP16	PWP40N	CPF20	1.5×40	S5	S10	S26	DT1-12
50	DRP20	PWP50N	CPF24	1.5×50	S6	S14	S32	DT1-16
63	DRP20	PWP63N	CPF24	1.5×63	S6	S14	S32	DT1-16
80	DRP25	PWP80N	CPF30	1.5×80	S6	S18	S38	DT1-20
100	DRP30	PWP100N	CPF35	1.5×100	S6	S18	S38	DT1-20

Mass

● Push side stroke adjusting type

kg [lb.]

Bore size mm [in.]	Zero stroke mass						Additional mass for each 1mm [0.0394in.] stroke	Mass of 1 sensor switch [with holder]		Mass of 1 knuckle	
	Basic type	Foot mounting type	Axial foot mounting type	Flange mounting type	Trunnion type	Trunnion type (with supporting brackets)		ZC□□ CS□□	□□ □□	Y type knuckle (with pin)	I type knuckle
40 [1.575]	1.57 [3.46]	1.70 [3.75]	1.77 [3.90]	1.94 [4.28]	2.05 [4.52]	2.55 [5.62]	0.00457 [0.01008]	0.04 [0.09]	0.05 [0.11]	0.27 [0.60]	0.16 [0.35]
50 [1.969]	2.53 [5.58]	2.70 [5.95]	2.85 [6.28]	2.92 [6.44]	3.08 [6.79]	3.58 [7.89]	0.00673 [0.01484]			0.34 [0.75]	0.21 [0.46]
63 [2.480]	3.38 [7.45]	3.61 [7.96]	3.90 [8.60]	3.91 [8.62]	4.08 [9.00]	4.58 [10.10]	0.00760 [0.01676]			0.34 [0.75]	0.21 [0.46]
80 [3.150]	6.10 [13.45]	6.48 [14.29]	6.95 [15.32]	7.70 [16.98]	7.26 [16.01]	7.98 [17.60]	0.01217 [0.02663]	0.04 [0.09]	0.06 [0.13]	0.87 [1.92]	0.62 [1.37]
100 [3.940]	8.45 [18.63]	8.92 [19.67]	9.73 [21.45]	10.67 [23.53]	9.98 [22.01]	10.70 [23.59]	0.01612 [0.03554]			1.47 [3.24]	1.24 [2.73]

Note: For lead wire length A (1000mm [39in.]).

Calculation example: For foot mounting type with bore size of 50mm, and stroke of 100 mm,
 $2.70 + (0.00673 \times 100) = 3.373\text{kg}$ [7.437lb.]

● Pull side stroke adjusting type

kg [lb.]

Bore size mm [in.]	Zero stroke mass						Additional mass for each 1mm [0.0394in.] stroke	Mass of 1 sensor switch [with holder]		Mass of 1 knuckle	
	Basic type	Foot mounting type	Axial foot mounting type	Flange mounting type	Trunnion type	Trunnion type (with supporting brackets)		ZC□□ CS□□	□□ □□	Y type knuckle (with pin)	I type knuckle
40 [1.575]	1.14 [2.51]	1.27 [2.80]	1.34 [2.95]	1.51 [3.33]	1.62 [3.57]	2.12 [4.67]	0.00300 [0.00662]	0.04 [0.09]	0.05 [0.11]	0.27 [0.60]	0.16 [0.35]
50 [1.969]	1.87 [4.12]	2.04 [4.50]	2.19 [4.83]	2.26 [4.98]	2.42 [5.34]	2.92 [6.44]	0.00428 [0.00944]			0.34 [0.75]	0.21 [0.46]
63 [2.480]	2.54 [5.60]	2.77 [6.11]	3.06 [6.75]	3.07 [6.77]	3.24 [7.14]	3.74 [8.25]	0.00515 [0.01136]			0.34 [0.75]	0.21 [0.46]
80 [3.150]	4.67 [10.30]	5.05 [11.14]	5.52 [12.17]	6.27 [13.83]	5.83 [12.86]	6.55 [14.44]	0.00834 [0.01839]	0.04 [0.09]	0.06 [0.13]	0.87 [1.92]	0.62 [1.37]
100 [3.940]	6.35 [14.00]	6.82 [15.04]	7.63 [16.82]	8.57 [18.90]	7.88 [17.38]	8.60 [18.96]	0.01061 [0.02340]			1.47 [3.24]	1.24 [2.73]

Note: For lead wire length A (1000mm [39in.]).

Calculation example: For foot mounting type with bore size of 50mm, and stroke of 100 mm,
 $2.04 + (0.00428 \times 100) = 2.468\text{kg}$ [5.442lb.]

Dimensions of Push Side Stroke Adjusting Basic Type (mm)

DDAP Bore size X Stroke

CAD DDAP Bore size

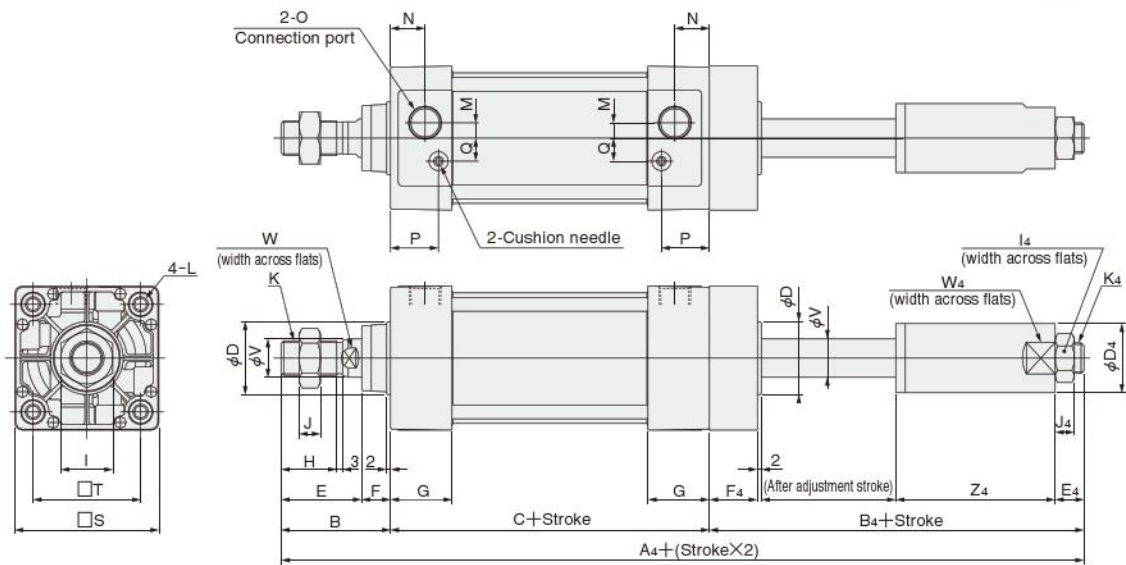

Bore mm [in.]	Code	A ₄	B	B ₄	C	D	D ₄	E	E ₄	F	F ₄	G	H	I	I ₄	J
40 [1.575]		254	49	112	93	32	30	34	11	15	25	31	21	22	19	8
50 [1.969]		274	57	124	93	38	36	42	14	15	25	31	29	27	22	11
63 [2.480]		277	57	124	96	38	36	42	14	15	25	32	29	27	22	11
80 [3.150]		321	75	138	108	44	45	54	17	21	35	36	37	32	27	13
100 [3.940]		321	75	138	108	50	50	54	17	21	35	36	37	36	27	14

Bore mm [in.]	Code	J ₄	K	K ₄	L	M	N	O	P	Q	S	T	V	W	W ₄	Z ₄
40 [1.575]		7	M14×1.5	M12×1.25	M6×1 Depth 14	4	18	Rc1/4	25.5	10	50	37	16	14	27	74
50 [1.969]		10	M18×1.5	M16×1.5	M6×1 Depth 14	7	18	Rc3/8	24	12	62	47	20	17	32	83
63 [2.480]		10	M18×1.5	M16×1.5	M8×1.25 Depth 14	8	18	Rc3/8	25	12	75	56	20	17	32	83
80 [3.150]		12	M22×1.5	M20×1.5	M10×1.5 Depth 15	11	20	Rc1/2	29	16	94	70	25	21	41	84
100 [3.940]		12	M26×1.5	M20×1.5	M10×1.5 Depth 15	12	20	Rc1/2	29	18	112	84	30	26	46	84

DYNA CYLINDERS

Dimensions of Push Side Stroke Adjusting Foot Mounting Type (mm)

DDAP Bore size X Stroke -1

Foot mounting bracket only
DDA Bore size -1

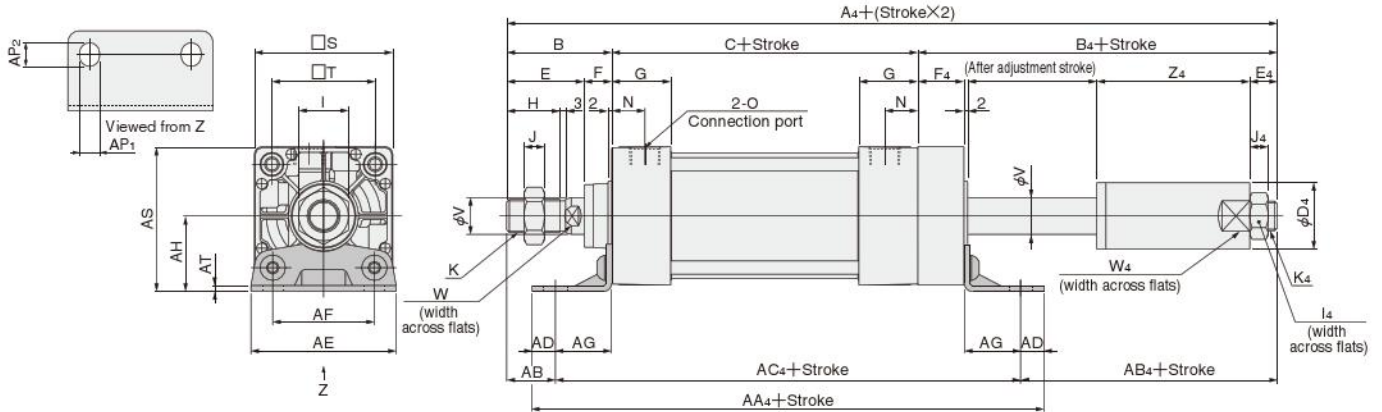

Bore mm [in.]	Code	A ₄	B	B ₄	C	D ₄	E	E ₄	F	F ₄	G	H	I	I ₄	J	J ₄	K	K ₄	N	O
40	[1.575]	254	49	112	93	30	34	11	15	25	31	21	22	19	8	7	M14×1.5	M12×1.25	18	Rc1/4
50	[1.969]	274	57	124	93	36	42	14	15	25	31	29	27	22	11	10	M18×1.5	M16×1.5	18	Rc3/8
63	[2.480]	277	57	124	96	36	42	14	15	25	32	29	27	22	11	10	M18×1.5	M16×1.5	18	Rc3/8
80	[3.150]	321	75	138	108	45	54	17	21	35	36	37	32	27	13	12	M22×1.5	M20×1.5	20	Rc1/2
100	[3.940]	321	75	138	108	50	54	17	21	35	36	37	36	27	14	12	M26×1.5	M20×1.5	20	Rc1/2

Bore mm [in.]	Code	S	T	V	W	W ₄	Z ₄	AA ₄	AB	AB ₄	AC ₄	AD	AE	AF	AG	AH	AP ₁	AP ₂	AS	AT
40	[1.575]	50	37	16	14	27	74	190	25.5	63.5	165	12.5	57	36	23.5	30	11	13	55	3.2
50	[1.969]	62	47	20	17	32	83	198	29	71	174	12	68	47	28	36.5	11	13	67.5	3.2
63	[2.480]	75	56	20	17	32	83	209	26	68	183	13	80	56	31	41	11	13	78.5	3.2
80	[3.150]	94	70	25	21	41	84	235	45	73	203	16	97	70	30	49	14	16	96	4
100	[3.940]	112	84	30	26	46	84	235	45	73	203	16	112	84	30	57	14	16	113	4

Dimensions of Push Side Stroke Adjusting Axial Foot Mounting Type (mm)

DDAP Bore size X Stroke -2

Axial foot mounting bracket only
DDA Bore size -2

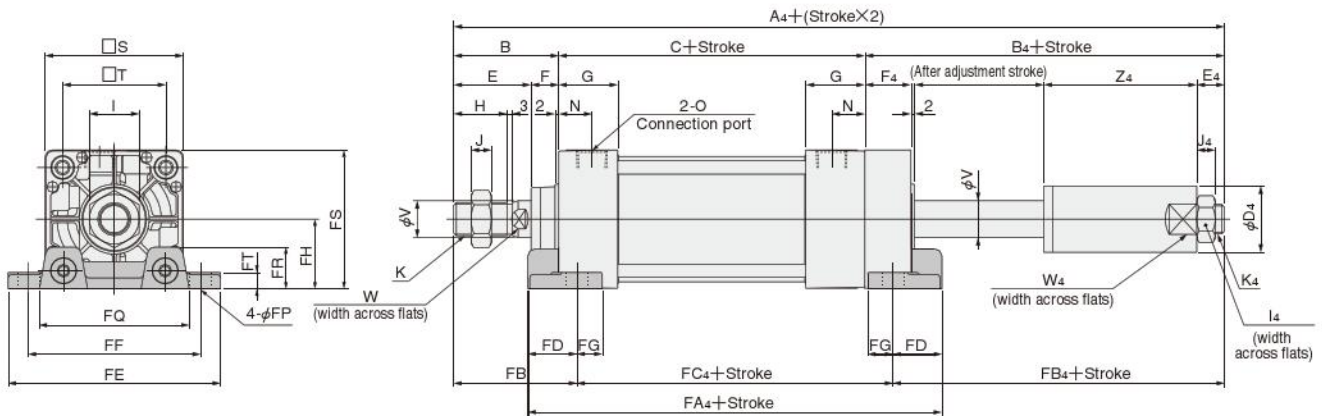

Bore mm [in.]	Code	A ₄	B	B ₄	C	D ₄	E	E ₄	F	F ₄	G	H	I	I ₄	J	J ₄	K	K ₄	N	O
40	[1.575]	254	49	112	93	30	34	11	15	25	31	21	22	19	8	7	M14×1.5	M12×1.25	18	Rc1/4
50	[1.969]	274	57	124	93	36	42	14	15	25	31	29	27	22	11	10	M18×1.5	M16×1.5	18	Rc3/8
63	[2.480]	277	57	124	96	36	42	14	15	25	32	29	27	22	11	10	M18×1.5	M16×1.5	18	Rc3/8
80	[3.150]	321	75	138	108	45	54	17	21	35	36	37	32	27	13	12	M22×1.5	M20×1.5	20	Rc1/2
100	[3.940]	321	75	138	108	50	54	17	21	35	36	37	36	27	14	12	M26×1.5	M20×1.5	20	Rc1/2

Bore mm [in.]	Code	S	T	V	W	W ₄	Z ₄	FA ₄	FB	FB ₄	FC ₄	FD	FE	FF	FG	FH	FP	FQ	FR	FS	FT
40	[1.575]	50	37	16	14	27	74	144	59	97	98	23	92	70	14	25	12	58	16	50	8
50	[1.969]	62	47	20	17	32	83	148	67	109	98	25	105	83	14	31	12	68	17	62	9
63	[2.480]	75	56	20	17	32	83	155	67	109	101	27	117	95	14	38	12	84	22	75.5	9
80	[3.150]	94	70	25	21	41	84	185	88	116	117	34	147	121	18	47	14	104	28	94	13
100	[3.940]	112	84	30	26	46	84	193	88	116	117	38	168	140	18	57	14	120	30	113	14

Dimensions of Push Side Stroke Adjusting Rod Side Flange Mounting Type (mm)

DDAP Bore size X Stroke -3

 Flange mounting bracket only
DDA Bore size -3

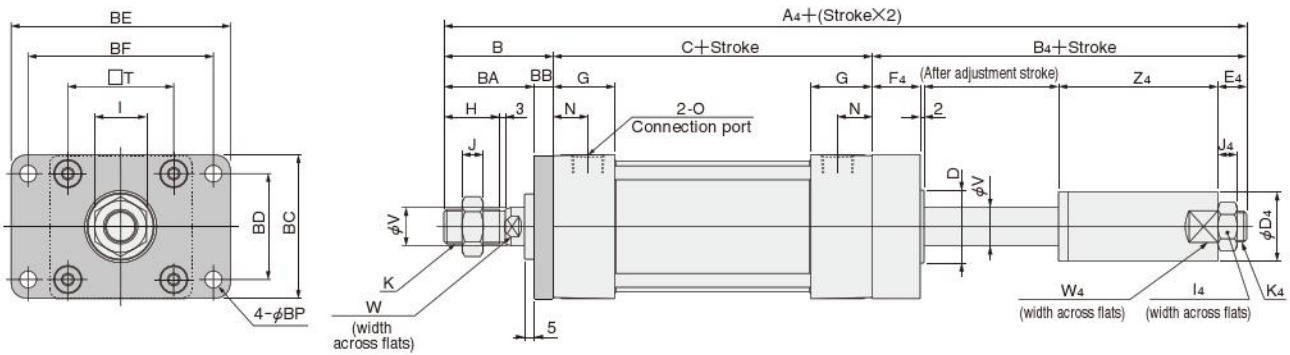

DYNA CYLINDERS

Bore mm [in.]	Code	A ₄	B	B ₄	C	D ₄	E ₄	F ₄	G	H	I	I ₄	J	J ₄	K	K ₄
40	[1.575]	254	49	112	93	30	11	25	31	21	22	19	8	7	M14×1.5	M12×1.25
50	[1.969]	274	57	124	93	36	14	25	31	29	27	22	11	10	M18×1.5	M16×1.5
63	[2.480]	277	57	124	96	36	14	25	32	29	27	22	11	10	M18×1.5	M16×1.5
80	[3.150]	321	75	138	108	45	17	35	36	37	32	27	13	12	M22×1.5	M20×1.5
100	[3.940]	321	75	138	108	50	17	35	36	37	36	27	14	12	M26×1.5	M20×1.5

Bore mm [in.]	Code	N	O	T	V	W	W ₄	Z ₄	BA	BB	BC	BD	BE	BF	BP
40	[1.575]	18	Rc1/4	37	16	14	27	74	39	10	52	36	84	70	7
50	[1.969]	18	Rc3/8	47	20	17	32	83	47	10	65	47	104	86	9
63	[2.480]	18	Rc3/8	56	20	17	32	83	47	10	76	56	116	98	9
80	[3.150]	20	Rc1/2	70	25	21	41	84	59	16	95	70	143	119	12
100	[3.940]	20	Rc1/2	84	30	26	46	84	59	16	115	84	162	138	12

Dimensions of Push Side Stroke Adjusting Trunnion Type (mm)

DDAP Bore size X Stroke -11

CAD Trunnion bracket only
DDA Bore size -11

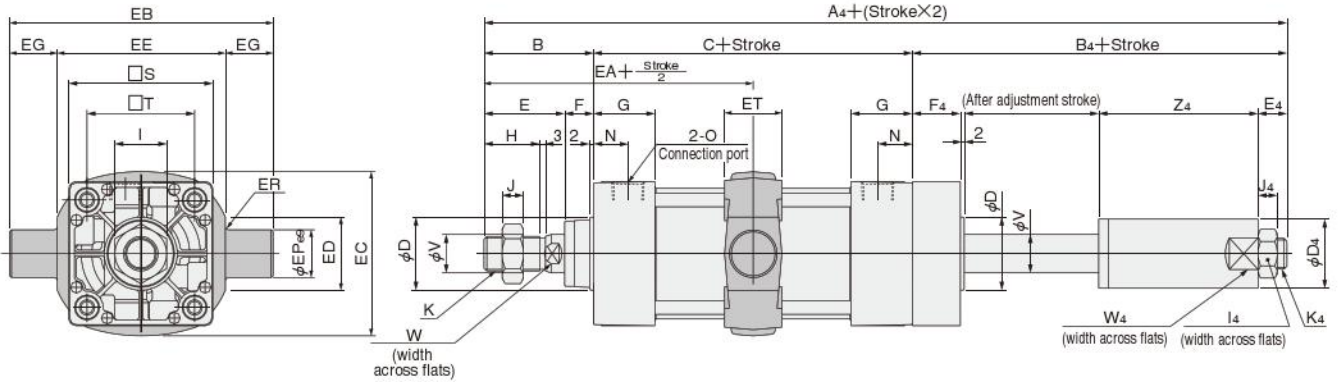

Bore mm (in.)	Code	A ₄	B	B ₄	C	D	D ₄	E	E ₄	F	F ₄	G	H	I	I ₄	J	J ₄	K	K ₄
40	[1.575]	254	49	112	93	32	30	34	11	15	25	31	21	22	19	8	7	M14×1.5	M12×1.25
50	[1.969]	274	57	124	93	38	36	42	14	15	25	31	29	27	22	11	10	M18×1.5	M16×1.5
63	[2.480]	277	57	124	96	38	36	42	14	15	25	32	29	27	22	11	10	M18×1.5	M16×1.5
80	[3.150]	321	75	138	108	44	45	54	17	21	35	36	37	32	27	13	12	M22×1.5	M20×1.5
100	[3.940]	321	75	138	108	50	50	54	17	21	35	36	37	36	27	14	12	M26×1.5	M20×1.5

Bore mm (in.)	Code	N	O	S	T	V	W	W ₄	Z ₄	EA	EB	EC	ED	EE	EG	EP	ER	ET
40	[1.575]	18	Rc1/4	50	37	16	14	27	74	95.5	113	60	30	63	25	25	R1.6	30
50	[1.969]	18	Rc3/8	62	47	20	17	32	83	103.5	126	72	30	76	25	25	R1.6	30
63	[2.480]	18	Rc3/8	75	56	20	17	32	83	105	138	87	40	88	25	25	R1.6	30
80	[3.150]	20	Rc1/2	94	70	25	21	41	84	129	164	105	40	114	25	25	R1.6	35
100	[3.940]	20	Rc1/2	112	84	30	26	46	84	129	182	129	44	132	25	25	R2	40

With Supporting Brackets DDAP Bore size X Stroke -11-11T

CAD Trunnion supporting bracket only
DDA Bore size -11T

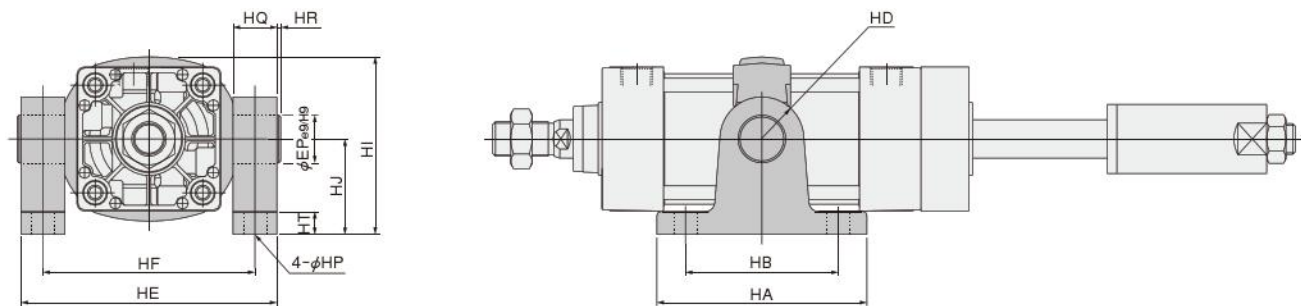

Bore mm (in.)	Code	HA	HB	HD	HE	HF	HI	HJ	HP	HQ	HR	HT	EP
40	[1.575]	111	80	R22	109	86	80	50	12 (Thru hole)	23	2	14	25
50	[1.969]	111	80	R22	122	99	86	50	12 (Thru hole)	23	2	14	25
63	[2.480]	111	80	R22	134	111	93.5	50	12 (Thru hole)	23	2	14	25
80	[3.150]	121	85	R22	160	137	122.5	70	14 (Thru hole)	23	2	14	25
100	[3.940]	121	85	R22	178	155	134.5	70	14 (Thru hole)	23	2	14	25

Dimensions of Pull Side Stroke Adjusting Basic Type (mm)

DDAE Bore size × Stroke

CAD DDAE Bore size

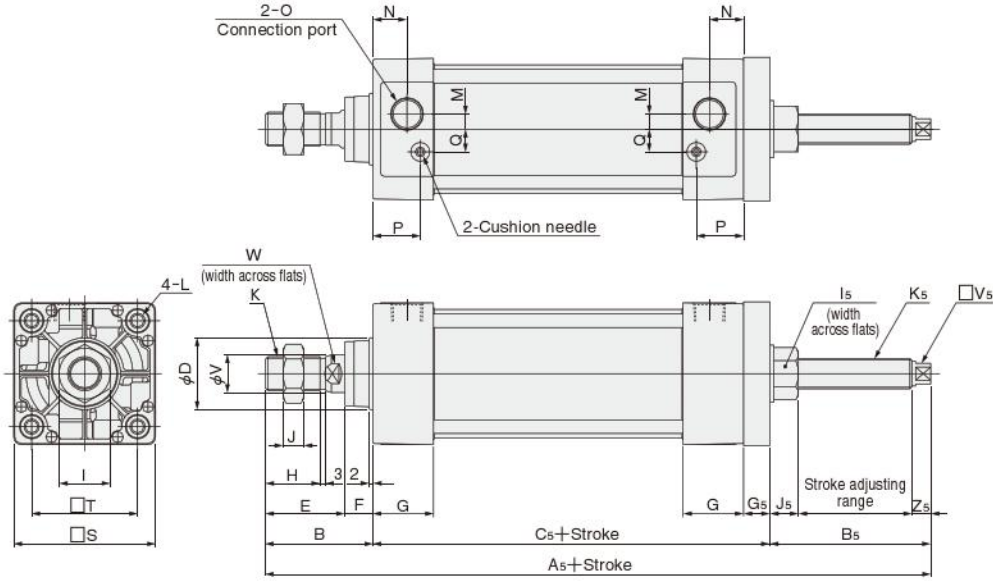

Bore mm [in.]	Code	A _s	B	B _s	C _s	D	E	F	G	G _s	H	I	I _s	J	J _s	K	K _s
40	[1.575]	238	49	82	107	32	34	15	31	14	21	22	19	8	12	M14×1.5	M12×1.25
50	[1.969]	249	57	85	107	38	42	15	31	14	29	27	24	11	15	M18×1.5	M16×1.5
63	[2.480]	252	57	85	110	38	42	15	32	14	29	27	24	11	15	M18×1.5	M16×1.5
80	[3.150]	296	75	91	130	44	54	21	36	22	37	32	30	13	19	M22×1.5	M20×1.5
100	[3.940]	296	75	91	130	50	54	21	36	22	37	36	30	14	19	M26×1.5	M20×1.5

Bore mm [in.]	Code	L	M	N	O	P	Q	S	T	V	V _s	W	Z _s
40	[1.575]	M6×1 Depth 14	4	18	Rc1/4	25.5	10	50	37	16	8	14	10
50	[1.969]	M6×1 Depth 14	7	18	Rc3/8	24	12	62	47	20	11	17	10
63	[2.480]	M8×1.25 Depth 14	8	18	Rc3/8	25	12	75	56	20	11	17	10
80	[3.150]	M10×1.5 Depth 15	11	20	Rc1/2	29	16	94	70	25	14	21	12
100	[3.940]	M10×1.5 Depth 15	12	20	Rc1/2	29	18	112	84	30	14	26	12

Dimensions of Pull Side Stroke Adjusting Foot Mounting Type (mm)

DDAE Bore size X Stroke -1

CAD Foot mounting bracket only
DDA Bore size -1

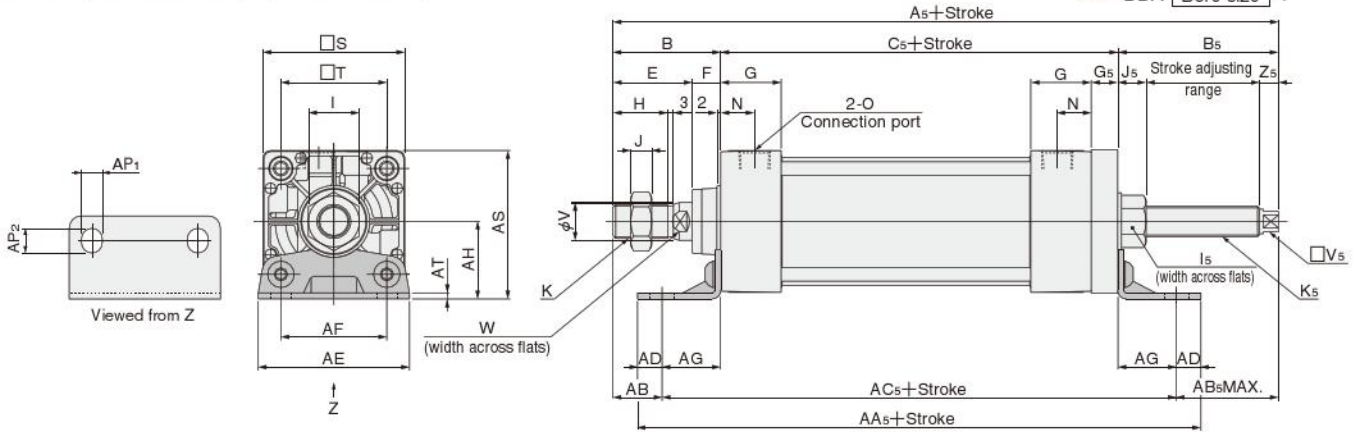

Bore mm [in.]	Code	A ₅	B	B ₅	C ₅	E	F	G	G ₅	H	I	I ₅	J	J ₅	K	K ₅
	40 [1.575]	238	49	82	107	34	15	31	14	21	22	19	8	12	M14×1.5	M12×1.25
	50 [1.969]	249	57	85	107	42	15	31	14	29	27	24	11	15	M18×1.5	M16×1.5
	63 [2.480]	252	57	85	110	42	15	32	14	29	27	24	11	15	M18×1.5	M16×1.5
	80 [3.150]	296	75	91	130	54	21	36	22	37	32	30	13	19	M22×1.5	M20×1.5
	100 [3.940]	296	75	91	130	54	21	36	22	37	36	30	14	19	M26×1.5	M20×1.5

Bore mm [in.]	Code	N	O	S	T	V	V ₅	W	Z ₅	AA ₅	AB	AB ₅	AC ₅	AD	AE	AF	AG	AH	AP ₁	AP ₂	AS	AT
	40 [1.575]	18	Rc1/4	50	37	16	8	14	10	179	25.5	58.5	154	12.5	57	36	23.5	30	11	13	55	3.2
	50 [1.969]	18	Rc3/8	62	47	20	11	17	10	187	29	57	163	12	68	47	28	36.5	11	13	67.5	3.2
	63 [2.480]	18	Rc3/8	75	56	20	11	17	10	198	26	54	172	13	80	56	31	41	11	13	78.5	3.2
	80 [3.150]	20	Rc1/2	94	70	25	14	21	12	222	45	61	190	16	97	70	30	49	14	16	96	4
	100 [3.940]	20	Rc1/2	112	84	30	14	26	12	222	45	61	190	16	112	84	30	57	14	16	113	4

Dimensions of Pull Side Stroke Adjusting Axial Foot Mounting Type (mm)

DDAE Bore size X Stroke -2

CAD Axial foot mounting bracket only
DDA Bore size -2

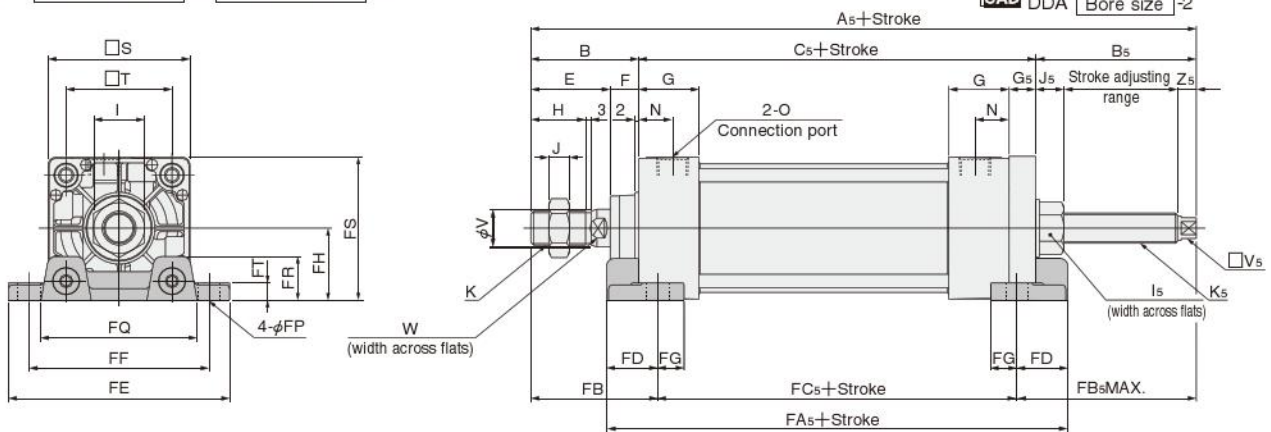

Bore mm [in.]	Code	A ₅	B	B ₅	C ₅	E	F	G	G ₅	H	I	I ₅	J	J ₅	K	K ₅
	40 [1.575]	238	49	82	107	34	15	31	14	21	22	19	8	12	M14×1.5	M12×1.25
	50 [1.969]	249	57	85	107	42	15	31	14	29	27	24	11	15	M18×1.5	M16×1.5
	63 [2.480]	252	57	85	110	42	15	32	14	29	27	24	11	15	M18×1.5	M16×1.5
	80 [3.150]	296	75	91	130	54	21	36	22	37	32	30	13	19	M22×1.5	M20×1.5
	100 [3.940]	296	75	91	130	54	21	36	22	37	36	30	14	19	M26×1.5	M20×1.5

Bore mm [in.]	Code	N	O	S	T	V	V ₅	W	Z ₅	FA ₅	FB	FB ₅	FC ₅	FD	FE	FF	FG	FH	FP	FQ	FR	FS	FT
	40 [1.575]	18	Rc1/4	50	37	16	8	14	10	133	59	92	87	23	92	70	14	25	12	58	16	50	8
	50 [1.969]	18	Rc3/8	62	47	20	11	17	10	137	67	95	87	25	105	83	14	31	12	68	17	62	9
	63 [2.480]	18	Rc3/8	75	56	20	11	17	10	144	67	95	90	27	117	95	14	38	12	84	22	75.5	9
	80 [3.150]	20	Rc1/2	94	70	25	14	21	12	172	88	104	104	34	147	121	18	47	14	104	28	94	13
	100 [3.940]	20	Rc1/2	112	84	30	14	26	12	180	88	104	104	38	168	140	18	57	14	120	30	113	14

Dimensions of Pull Side Stroke Adjusting Rod Side Flange Mounting Type (mm)

DDAE Bore size X Stroke -3

CAD Flange mounting bracket only
DDA Bore size -3

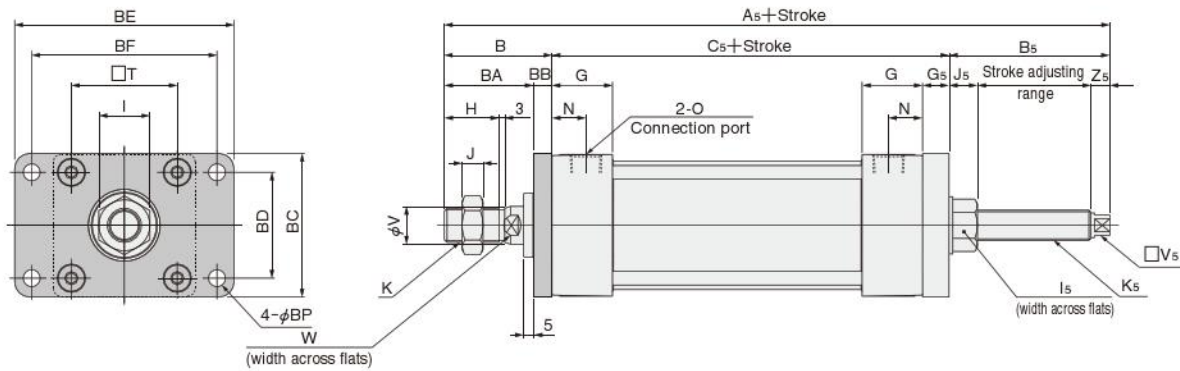

Bore mm [in.]	Code	A ₅	B	B ₅	C ₅	G	G ₅	H	I	I ₅	J	J ₅	K	K ₅
40	[1.575]	238	49	82	107	31	14	21	22	19	8	12	M14×1.5	M12×1.25
50	[1.969]	249	57	85	107	31	14	29	27	24	11	15	M18×1.5	M16×1.5
63	[2.480]	252	57	85	110	32	14	29	27	24	11	15	M18×1.5	M16×1.5
80	[3.150]	296	75	91	130	36	22	37	32	30	13	19	M22×1.5	M20×1.5
100	[3.940]	296	75	91	130	36	22	37	36	30	14	19	M26×1.5	M20×1.5

Bore mm [in.]	Code	N	O	T	V	V ₅	W	Z ₅	BA	BB	BC	BD	BE	BF	BP
40	[1.575]	18	Rc1/4	37	16	8	14	10	39	10	52	36	84	70	7
50	[1.969]	18	Rc3/8	47	20	11	17	10	47	10	65	47	104	86	9
63	[2.480]	18	Rc3/8	56	20	11	17	10	47	10	76	56	116	98	9
80	[3.150]	20	Rc1/2	70	25	14	21	12	59	16	95	70	143	119	12
100	[3.940]	20	Rc1/2	84	30	14	26	12	59	16	115	84	162	138	12

DYNA CYLINDERS

Dimensions of Pull Side Stroke Adjusting Trunnion Type (mm)

DDAE Bore size X Stroke -11

CAD Trunnion bracket only
DDA Bore size -11

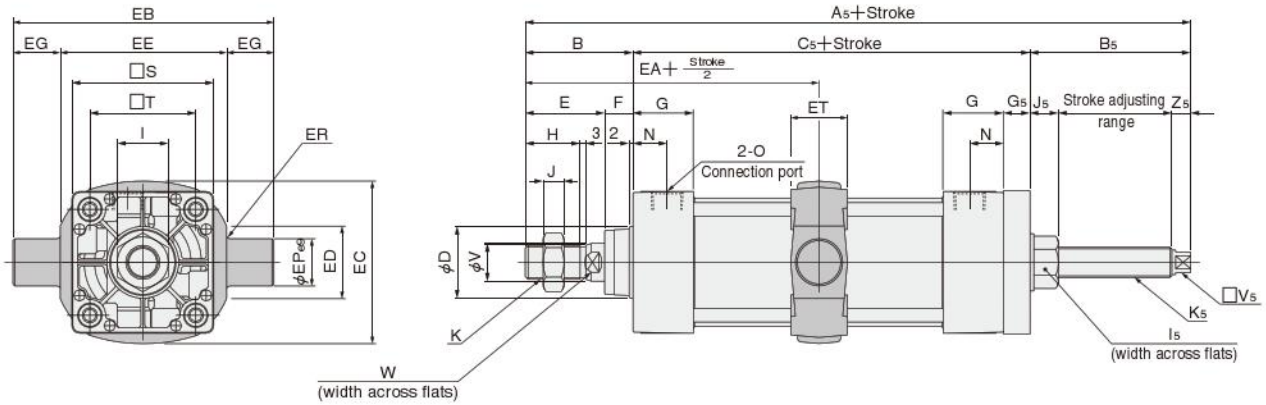

Bore mm (in.)	Code	A _s	B	B _s	C _s	D	E	F	G	G _s	H	I	I _s	J	J _s	K	K _s
40	[1.575]	238	49	82	107	32	34	15	31	14	21	22	19	8	12	M14×1.5	M12×1.25
50	[1.969]	249	57	85	107	38	42	15	31	14	29	27	24	11	15	M18×1.5	M16×1.5
63	[2.480]	252	57	85	110	38	42	15	32	14	29	27	24	11	15	M18×1.5	M16×1.5
80	[3.150]	296	75	91	130	44	54	21	36	22	37	32	30	13	19	M22×1.5	M20×1.5
100	[3.940]	296	75	91	130	50	54	21	36	22	37	36	30	14	19	M26×1.5	M20×1.5

Bore mm (in.)	Code	N	O	S	T	V	V _s	W	Z _s	EA	EB	EC	ED	EE	EG	EP	ER	ET
40	[1.575]	18	Rc1/4	50	37	16	8	14	10	95.5	113	60	30	63	25	25	R1.6	30
50	[1.969]	18	Rc3/8	62	47	20	11	17	10	103.5	126	72	30	76	25	25	R1.6	30
63	[2.480]	18	Rc3/8	75	56	20	11	17	10	105	138	87	40	88	25	25	R1.6	30
80	[3.150]	20	Rc1/2	94	70	25	14	21	12	129	164	105	40	114	25	25	R1.6	35
100	[3.940]	20	Rc1/2	112	84	30	14	26	12	129	182	129	44	132	25	25	R2	40

● With Supporting Brackets DDAE Bore size X Stroke -11-11T

CAD Trunnion supporting bracket only
DDA Bore size -11T

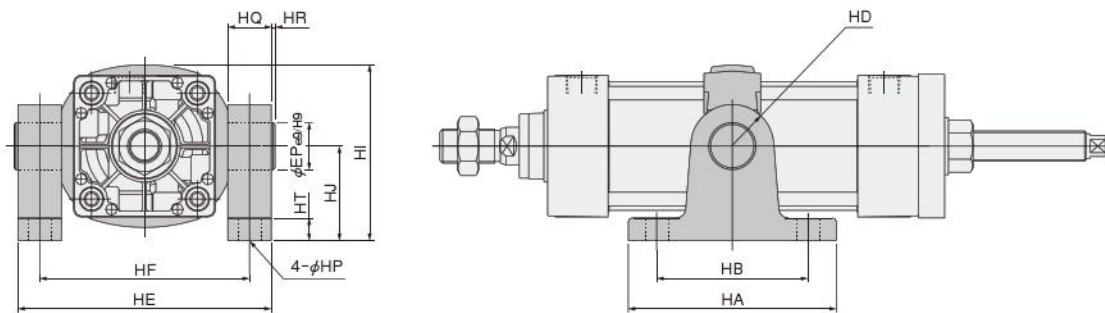

Bore mm (in.)	Code	HA	HB	HD	HE	HF	HI	HJ	HP	HQ	HR	HT	EP
40	[1.575]	111	80	R22	109	86	80	50	12 (Thru hole)	23	2	14	25
50	[1.969]	111	80	R22	122	99	86	50	12 (Thru hole)	23	2	14	25
63	[2.480]	111	80	R22	134	111	93.5	50	12 (Thru hole)	23	2	14	25
80	[3.150]	121	85	R22	160	137	122.5	70	14 (Thru hole)	23	2	14	25
100	[3.940]	121	85	R22	178	155	134.5	70	14 (Thru hole)	23	2	14	25

SENSOR SWITCHES

Symbol

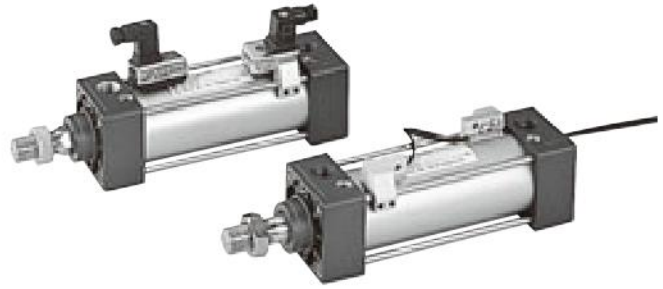
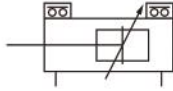

DYNMA CYLINDERS

Order Codes

● Without mounting holder — **ZC130** **A**

● With mounting holder — **ZC130** **A** — **NDDA** **40**

- Sensor switch model**
- ZC130** — 2-lead wire Solid state type with indicator lamp
DC10~28V
 - ZC153** — 3-lead wire Solid state type with indicator lamp
DC4.5~28V
 - CS5T** — 2-lead wire Reed switch type without indicator lamp
DC5~28V, AC85~115V
 - CS11T** — 2-lead wire Reed switch type with indicator lamp
DC10~28V
 - CS2F** — DIN connector Reed switch type with indicator lamp
AC85~230V
 - CS3F** — DIN connector Reed switch type with indicator lamp
DC10~30V
 - CS4F** — DIN connector Reed switch type with indicator lamp
DC10~30V
 - CS5F** — DIN connector Reed switch type without indicator lamp
DC3~30V

NDDA: Applicable to other than **CS□F**
NDF: Applicable to **CS□F** only

Lead wire length
(Applicable to other than **CS□F** only)
A — 1000mm [39in.]
B — 3000mm [118in.]

Bore size

● Order codes for mounting holders only

C1 — **NDDA** **40**

NDDA: Applicable to other than **CS□F**
Blank: For **CS□F**

Sensor type
C1: Solid state type for **ZC1□□**
Reed switch type for **CS□T**
DF: Reed switch type for **CS□F**

Bore size

- 32** — For ϕ 32 [1.260in.]
- 40** — For ϕ 40 [1.575in.]
- 50** — For ϕ 50 [1.969in.]
- 63** — For ϕ 63 [2.480in.]
- 80** — For ϕ 80 [3.150in.]
- 100** — For ϕ 100 [3.940in.]
- 125** — For ϕ 125 [4.921in.]

● For details of sensor switches, see p.1544.

Sensor Switches and Mounting Holders

● DYNMA cylinder sensor switches come in 2 types, and 2 corresponding types of mounting holders are available. See the following for details.

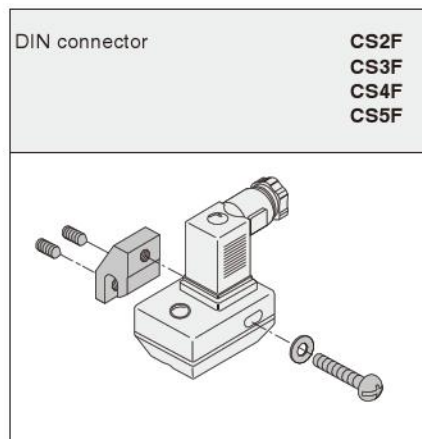
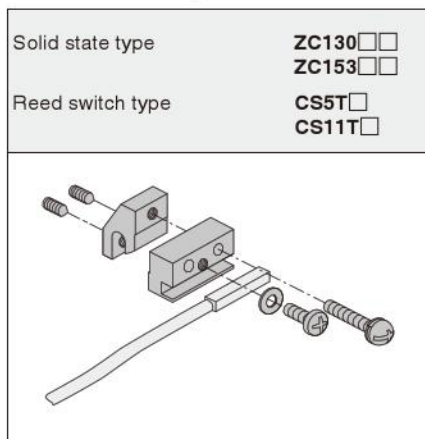

Minimum Cylinder Strokes When Using Sensor Switches

mm

Sensor switch model	Bore size mm [in.]	2pcs. mounting				1pc. mounting		
		Mounting 2 pcs. on a tie rod		Mounting 1 pc. on each tie rod		Rod side	Head side	
		In a straight line	In staggered positions	1-plane mounting	2-plane mounting			
Solid state type	ZC130 ZC153	32 [1.260]	55 (90)	15 (90)	48 (90)	15 (90)	15 (66)	
		40 [1.575]	55 (90)	15 (90)	48 (90)	15 (90)	15 (66)	
		50 [1.969]	55 (90)	15 (90)	15 (90)	15 (90)	15 (66)	
		63 [2.480]	58 (93)	15 (93)	15 (93)	15 (93)	15 (63)	
		80 [3.150]	58 (99)	15 (99)	15 (99)	15 (99)	15 (69)	
		100 [3.940]	58 (99)	15 (99)	15 (99)	15 (99)	15 (69)	
		125 [4.921]	58 (99)	15 (99)	15 (99)	15 (99)	15 (69)	
Reed switch type	CS5T CS11T	32 [1.260]	55 (90)	15 (90)	48 (90)	15 (90)	15 (66)	
		40 [1.575]	55 (90)	15 (90)	48 (90)	15 (90)	15 (66)	
		50 [1.969]	55 (90)	15 (90)	15 (90)	15 (90)	15 (66)	
		63 [2.480]	58 (93)	15 (93)	15 (93)	15 (93)	15 (63)	
		80 [3.150]	58 (99)	15 (99)	15 (99)	15 (99)	15 (69)	
		100 [3.940]	58 (99)	15 (99)	15 (99)	15 (99)	15 (69)	
		125 [4.921]	58 (99)	15 (99)	15 (99)	15 (99)	15 (69)	
	CS□F	32 [1.260]	55 (93)	33 (93)	55 (93)	25 (93)	20 (77)	
		40 [1.575]	55 (93)	33 (93)	55 (93)	25 (93)	20 (77)	
		50 [1.969]	55 (93)	33 (93)	55 (93)	25 (93)	20 (77)	
		63 [2.480]	55 (96)	33 (96)	55 (96)	25 (96)	20 (74)	
		80 [3.150]	55 (101)	33 (101)	25 (101)		20 (101)	20 (79)
		100 [3.940]	55 (99)	33 (106)	25 (106)		20 (106)	20 (84)
		125 [4.921]	55 (99)	33 (106)	25 (106)		20 (106)	20 (84)

Remark: Figures in parentheses () are for trunnion type.

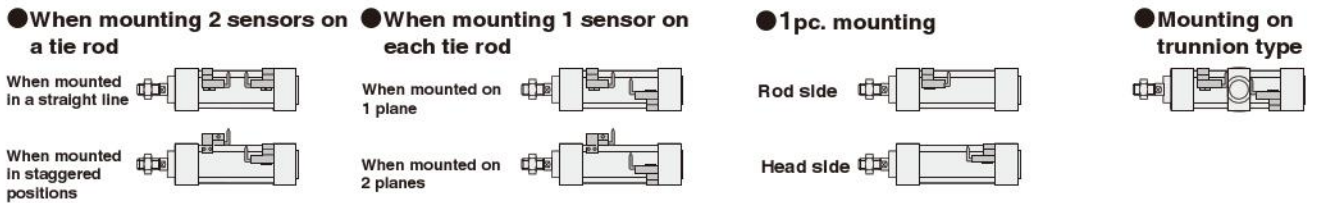

Sensor Switch Operating Range, Response Differential, and Maximum Sensing Location

● ZC1□□ type, CS□T type, CS□F type

● Operating range: ℓ

The distance the piston travels in one direction, while the switch is in the ON position.

● Response differential: C

The distance between the point where the piston turns the switch ON and the point where the switch is turned OFF as the piston travels in the opposite direction.

mm [in.]

Sensor switches model	Solid state type	Reed switch type		
	ZC130, ZC153	CS5T	CS11T	CS□F
Operating range: ℓ	2~6 [0.079~0.236]	6~15 [0.236~0.591]		
Response differential: C	1.5 [0.059] MAX.	2.5 [0.098] MAX.		
Maximum sensing location	8.5 [0.335]	7 [0.276]	10.5 [0.413]	16 [0.630]

Notes: 1. Figures in the grommet type are lengths measured from the switch's opposite end side to the lead wire, while the figures in connector type are lengths measured from the connector side's end surface.

2. The above table shows reference values.

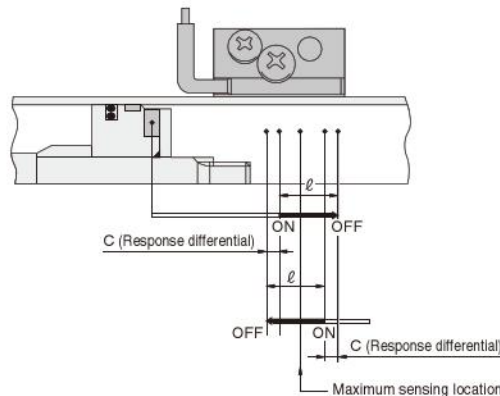

Mounting Location of Sensor Switch

When the sensor switch is mounted in the locations shown in the diagram (figures in the table are reference values), the magnet comes to the sensor switch's maximum sensing location at the end of the stroke.

● Grommet type

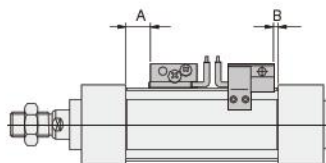

Grommet type enlarged view

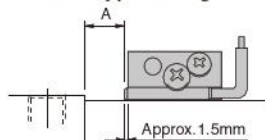

● Connector type

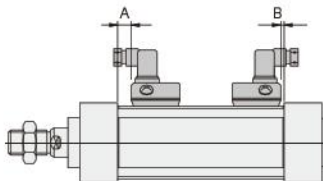

● Precaution for mounting

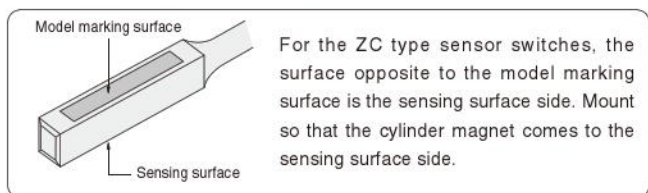

For the ZC type sensor switches, the surface opposite to the model marking surface is the sensing surface side. Mount so that the cylinder magnet comes to the sensing surface side.

● Single rod basic type and non-rotating double rod type

mm [in.]

Sensor switch model	Bore size Code	32	40	50	63	80	100	125	
		Solid state type	ZC130 ZC153	A 9 [0.354]	9 5 [0.197]	9 5 [0.197]	9.5 5.5 [0.217]	12.5 6.5 [0.256]	12.5 6.5 [0.256]
Reed switch type	CS5T	A	10.5 [0.413]	10.5 [0.413]	10.5 [0.413]	11 [0.433]	14 [0.551]	14 [0.551]	16 [0.630]
		B	6.5 [0.256]	6.5 [0.256]	6.5 [0.256]	7 [0.276]	8 [0.315]	8 [0.315]	12 [0.472]
	CS11T	A	7 [0.276]	7 [0.276]	7 [0.276]	7.5 [0.295]	10.5 [0.413]	10.5 [0.413]	12.5 [0.492]
		B	3 [0.118]	3 [0.118]	3 [0.118]	3.5 [0.138]	4.5 [0.177]	4.5 [0.177]	8.5 [0.335]
	CS□F	A	3.5 [0.138]	3.5 [0.138]	3.5 [0.138]	4 [0.157]	7 [0.276]	7 [0.276]	9 [0.354]
		B	0	0	0	0	1 [0.039]	1 [0.039]	5 [0.197]

Caution: The reed sensor switch cannot be mounted on the head side in any direction other than that shown in the diagram.

● Standard double rod type

mm [in.]

Sensor switch model	Bore size Code	32	40	50	63	80	100	125	
		Solid state type	ZC130 ZC153	A 9.5 [0.374]	9 5 [0.197]	9.5 4.5 [0.177]	9.5 5.5 [0.217]	12.5 6.5 [0.256]	12.5 6.5 [0.256]
Reed switch type	CS5T	A	11 [0.433]	10.5 [0.413]	11 [0.433]	11 [0.433]	14 [0.551]	14 [0.551]	16 [0.630]
		B	6 [0.236]	6.5 [0.256]	6 [0.236]	7 [0.276]	8 [0.315]	8 [0.315]	12 [0.472]
	CS11T	A	7.5 [0.295]	7 [0.276]	7.5 [0.295]	7.5 [0.295]	10.5 [0.413]	10.5 [0.413]	12.5 [0.492]
		B	2.5 [0.098]	3 [0.118]	2.5 [0.098]	3.5 [0.138]	4.5 [0.177]	4.5 [0.177]	8.5 [0.335]
	CS□F	A	4 [0.157]	3.5 [0.138]	4 [0.157]	4 [0.157]	7 [0.276]	7 [0.276]	9 [0.354]
		B	0	0	0	0	1 [0.039]	1 [0.039]	5 [0.197]

Caution: The reed sensor switch cannot be mounted on the head side in any direction other than that shown in the diagram.

Dimensions of Sensor Switch

● ZC130, ZC153, CS□T

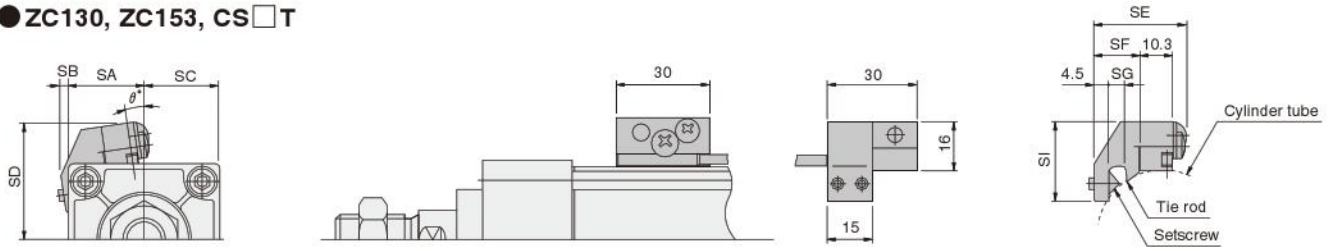

Code mm [in]	SA	SB	SC	SD	SE	SF	SG	SI	θ
32 [1.260]	27	5	17	35	29.8	15.5	6	25.5	1
40 [1.575]	26.1	2	23.9	38.4	29.8	15.5	6	25.5	10
50 [1.969]	27.1	0.7	34.9	43.4	29.8	15.5	6	25.5	10
63 [2.480]	28.3	0	46.7	48.6	31.8	17.5	8	24.5	18
80 [3.150]	30.9	0	63.1	55.9	33.3	19	9.5	22.5	22
100 [3.940]	32.2	0	79.8	63.6	33.3	19	9.5	22.5	24.5
125 [4.921]	36.5	—	99.5	75	37.5	24.8	11	15.5	27.5

● CS□F

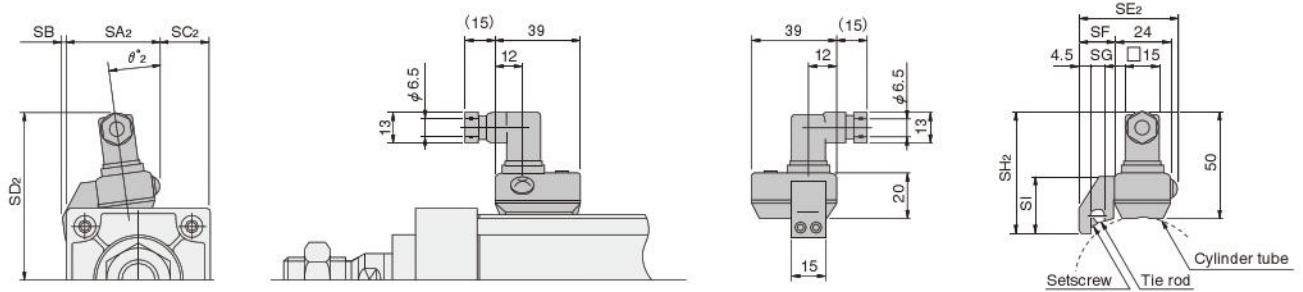

Code mm [in]	SA ₂	SB	SC ₂	SD ₂	SE ₂	SF	SG	SH ₂	SI	θ ₂
32 [1.260]	41.5	5	2.5	66.5	43	15.5	6	56.5	25.5	2.3
40 [1.575]	33.5	1.5	16.5	70	43	15.5	6	56.5	25.5	12
50 [1.969]	40	0.5	22	74.5	43	15.5	6	56.5	25.5	10
63 [2.480]	40.5	0	34.5	79.5	45	17.5	6	55.5	24.5	19
80 [3.150]	42.5	—	51.5	86	46.5	19	9.5	53.5	22.5	23
100 [3.940]	44	—	68	93.5	46.5	19	9.5	53.5	22.5	25
125 [4.921]	49.5	—	86.5	106.5	52.5	25	11	50.5	15.5	23.5

Instructions for Mounting and Moving Sensor Switch

ZC1□□, CS□T types

Requiring parts for mounting 1 sensor switch on a cylinder

- ① Sensor Switch
- ② Washer × 1
- ③ Screw (short) × 1
- ④ Sensor holder × 1
- ⑤ Setscrew × 2
- ⑥ Tie rod
- ⑦ Screw (long) × 1
- ⑧ Sub-holder × 1

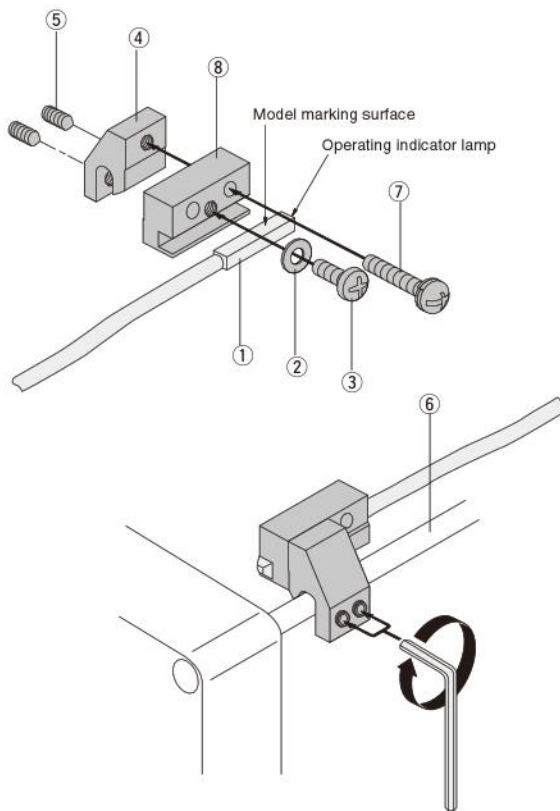

1. ● Align the female thread of sensor holder ④ to the position of the sub-holder ⑧'s thru hole, and use a screw (long) ⑦ to assemble.
 - Two thru holes are available for ⑧. Either one can be used.
 - The appropriate tightening torque for ⑦ is 70 N·cm [6.2in·lbf].
2. ● Install the sensor switch ① with the model marking surface facing upward, and fit it on the groove of ⑧.
 - Align the edges of the body ① and indicator lamp (or the cap) to the end plane of ⑧, and assemble. To protect ①, always assemble so that the body ① does not protrude from the end surface of ⑧.
 - The appropriate tightening torque for the screw (short) ③ is 70N·cm [6.2in·lbf].
3. ● Two setscrews ⑤ are temporarily fixed ④ in place.
 - Fit ④ that was assembled with ① and ⑧ onto the tie rod ⑥, and align it to the designated position. Then use an Allen wrench (width across flats B = 2) to tighten ⑤ and secure it in place. Always secure it so that the bottom surface of ⑧ is in contact with the cylinder tube.
 - The appropriate tightening torque for ⑤ is 70 N·cm [6.2in·lbf].
 - There are four ⑥s on the cylinder, and ④ can be installed on any of them. In addition, ④ can be fitted in any direction.
 - Loosening the 2 screws ⑤ allows ④ to be moved freely along ⑥.

DYNA CYLINDERS

CS□F type

Requiring parts for mounting 1 sensor switch on a cylinder

- ① Sensor Switch
- ② Washer × 1
- ③ Screw × 1
- ④ Sensor holder × 1
- ⑤ Setscrew × 2
- ⑥ Tie rod

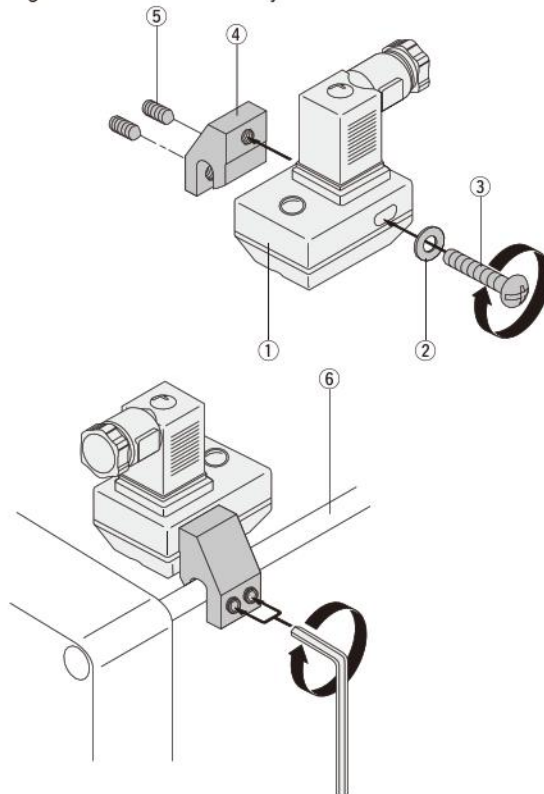

1. ● For the sensor switch ①, align the female thread of sensor holder ④ to any required location of the ①'s thru hole (oval), and assemble.
 - The appropriate tightening torque for the screw ③ is 70N·cm [6.2in·lbf].
2. ● Use 2 setscrews ⑤ to temporarily fix ④ in place.
 - Fit ④ that was assembled with ① onto the tie rod ⑥, and align it to the designated position. Then use an Allen wrench (width across flats B = 2) to tighten ⑤ and secure it in place. Always secure it so that the bottom surface of ① is in contact with the cylinder tube.
 - To detect the head side end of stroke, mount ① so that the connector wiring port faces toward the head cover side, as shown in the diagram to the left.
 - The appropriate tightening torque for ⑤ is 70N·cm [6.2in·lbf].
 - There are four ⑥s on the cylinder, and ④ can be installed on any of them. In addition, ④ can be fitted in any direction.
 - Loosening the 2 screws ⑤ allows ④ to be moved freely along ⑥.

KNUCKLES AND BELLOWS



Dimensions of Knuckle (mm)

● Y type

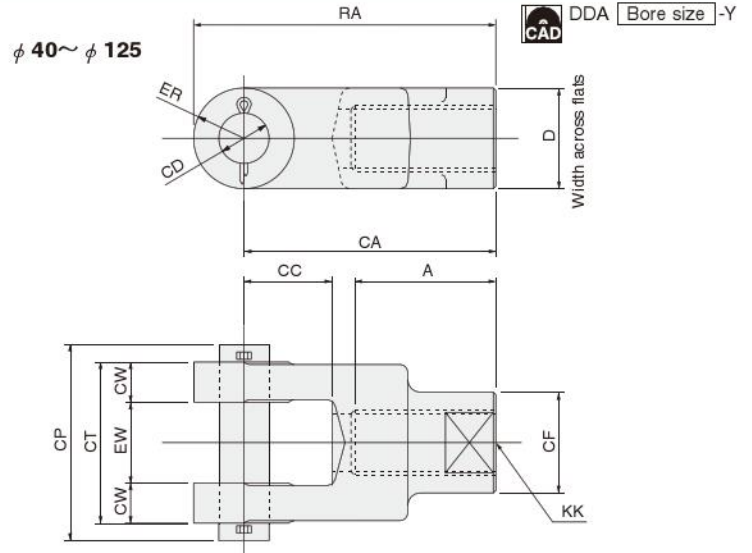
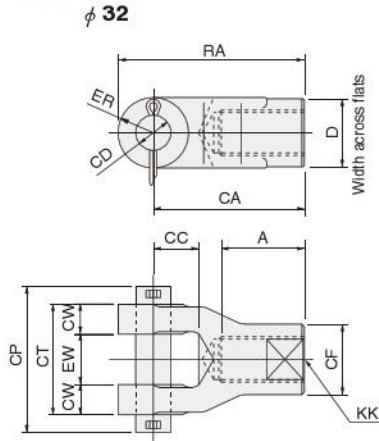

Bore mm [in.]	Code	A	CA	CC	CD	CF	CP	CT	CW	D	ER	EW	KK (other than non-rotating)	KK (non-rotating)	RA
32 [1.260]	23	55	20	$\phi 12_{H9/18}$	$\phi 24$	46	32	32	8	24	R12	$16^{+1.5}_{+0.5}$	M10×1.25	—	67
40 [1.575]	18	46	16	$\phi 12_{H9/18}$	$\phi 25$	48	48	36	9	—	R12.5	$18^{+0.4}_{+0.1}$	M14×1.5	M12×1.25	58.5
50 [1.969]	22	46	16	$\phi 12_{H9/18}$	$\phi 25$	48	48	36	9	—	R12.5	$18^{+0.4}_{+0.1}$	M18×1.5	M18×1.5	58.5
63 [2.480]	22	50	20	$\phi 16_{H9/18}$	$\phi 32$	56	44	44	11	—	R16	$22^{+0.4}_{+0.1}$	M18×1.5	M18×1.5	66
80 [3.150]	30	75	25	$\phi 20_{H9/18}$	$\phi 40$	68	68	56	14	—	R20	$28^{+0.4}_{+0.1}$	M22×1.5	M22×1.5	95
100 [3.940] (other than non-rotating)	34	75	25	$\phi 20_{H9/18}$	$\phi 40$	68	68	56	14	—	R20	$28^{+0.4}_{+0.1}$	M26×1.5	—	95
100 [3.940] (non-rotating)	34	75	25	$\phi 20_{H9/18}$	$\phi 40$	68	68	56	14	—	R20	$28^{+0.4}_{+0.1}$	—	M22×1.5	95
125 [4.921]	56	100	35	$\phi 20_{H9/18}$	$\phi 40$	78	78	64	16	40	R20	$32^{+1.5}_{+0.5}$	M27×2	—	120

● I type

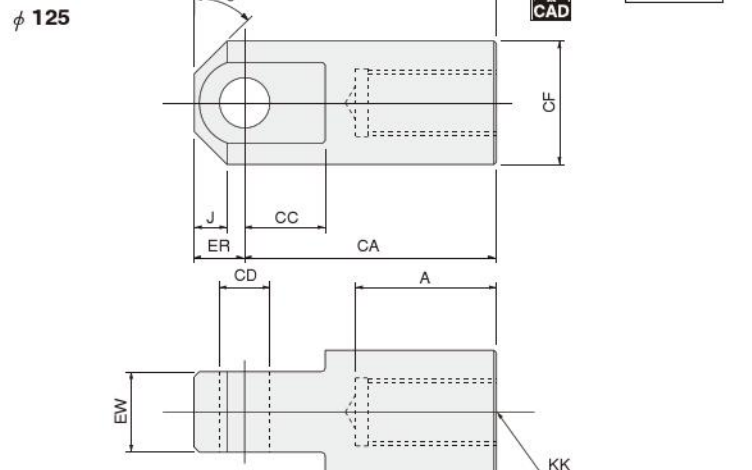
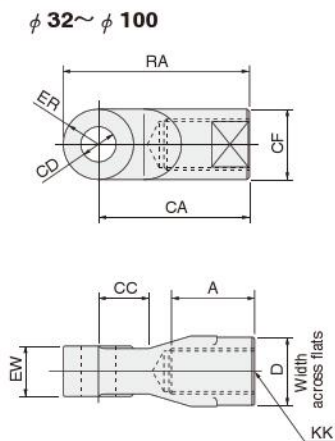

Bore mm [in.]	Code	A	CA	CC	CD	CF	D	ER	EW	J	KK (other than non-rotating)	KK (non-rotating)	RA
32 [1.260]	23	55	20	$\phi 12_{H9}$	$\phi 24$	—	24	R12	$16^{0}_{-0.1}$	—	M10×1.25	—	67
40 [1.575]	18	46	16	$\phi 12_{H9}$	$\phi 25$	—	—	R12.5	$18^{0}_{-0.1}$	—	M14×1.5	M12×1.25	58.5
50 [1.969]	22	46	16	$\phi 12_{H9}$	$\phi 25$	—	—	R12.5	$18^{0}_{-0.1}$	—	M18×1.5	M18×1.5	58.5
63 [2.480]	22	50	20	$\phi 16_{H9}$	$\phi 32$	—	—	R16	$22^{0}_{-0.1}$	—	M18×1.5	M18×1.5	66
80 [3.150]	30	75	25	$\phi 20_{H9}$	$\phi 40$	—	—	R20	$28^{0}_{-0.1}$	—	M22×1.5	M22×1.5	95
100 [3.940] (other than non-rotating)	34	75	25	$\phi 20_{H9}$	$\phi 40$	—	—	R20	$28^{0}_{-0.1}$	—	M26×1.5	—	95
100 [3.940] (non-rotating)	34	75	25	$\phi 20_{H9}$	$\phi 40$	—	—	R20	$28^{0}_{-0.1}$	—	—	M22×1.5	95
125 [4.921]	56	100	32	$\phi 20_{H9}$	$\phi 49$	—	—	20	$32^{0}_{-0.1}$	13	M27×2	—	120

Dimensions of Bellows (mm [In.])

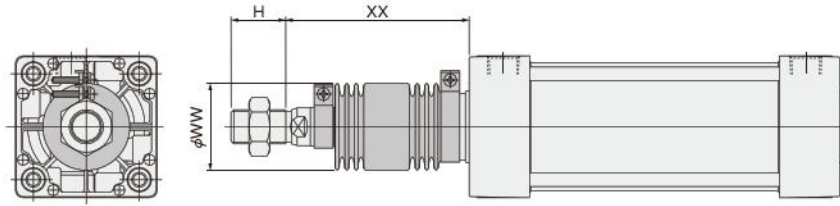

Bore size mm [in.]	Code	WW				XX				H
		Nylon tarpaulin	Chloroprene	Conex	Alumix	Nylon tarpaulin	Chloroprene	Conex	Alumix	
32 [1.260]		36 [1.42]	36 [1.42]	61 [2.40]	36 [1.42]	1/3 stroke + 48 [1.89]	1/3 stroke + 48 [1.89]	1/2 stroke + 48 [1.89]	1/2 stroke + 48 [1.89]	19 [0.75]
40 [1.575]		41 [1.61]	41 [1.61]	61 [2.40]	41 [1.61]					21 [0.83]
50 [1.969]		47 [1.85]	47 [1.85]	61 [2.40]	47 [1.85]	1/3 stroke + 53 [2.09]	1/3 stroke + 53 [2.09]	1/2 stroke + 53 [2.09]	1/2 stroke + 53 [2.09]	29 [1.14]
63 [2.480]		47 [1.85]	47 [1.85]	61 [2.40]	47 [1.85]					29 [1.14]
80 [3.150]		56 [2.20]	56 [2.20]	61 [2.40]	56 [2.20]	1/4 stroke + 58 [2.28]	1/4 stroke + 58 [2.28]	2/5 stroke + 58 [2.28]	2/5 stroke + 58 [2.28]	37 [1.46]
100 [3.940]		61 [2.40]	61 [2.40]	61 [2.40]	61 [2.40]					37 [1.46]
125 [4.921]		71 [2.80]	71 [2.80]	71 [2.80]	71 [2.80]	1/4 stroke + 59 [2.32]	1/4 stroke + 59 [2.32]	2/5 stroke + 59 [2.32]	2/5 stroke + 59 [2.32]	50 [1.97]

● Bellows Specifications

Type	Specifications	Contents	Heat resistant temperature °C [°F]
Nylon tarpaulin (standard)		Coating vinyl to nylon cloth	80 [176]
Chloroprene		Coating chloroprene to nylon cloth	100 [212]
Conex		Coating silicone to Conex cloth (no use of asbestos)	200 [392]
Alumix		Coating aluminum foil to asbestos cloth	250 [482]

Note: The temperatures shown are the bellows' own durable temperatures, and are not temperatures for cylinder use.

Order Codes of Mounting Brackets and Knuckles

● Mounting bracket



Cylinder type

- NDDA — DYNA cylinder
- NDDAR — DYNA cylinder with brake
- NDDAE — DYNA pull side stroke adjusting cylinder
- NDDAP — DYNA push side stroke adjusting cylinder

Mounting bracket

- 1 — Foot mounting type (One set of 2 units)
- 2 — Axial foot mounting type (One set of 2 units)
- 3 — Rod side flange mounting type^{Note}
- 5 — Head side flange mounting type
- 7 — Clevis mounting type (with pin)
- 7-7C — Clevis mounting type (with supporting bracket)
- 8 — Pivot mounting type
- 11 — Trunnion type
- 11-11T — Trunnion type (with supporting brackets)

Note: The rod side flange cannot be retrofitted with the bellows type.

Bore size

- 32 — For φ 32 [1.260in.]
- 40 — For φ 40 [1.575in.]
- 50 — For φ 50 [1.969in.]
- 63 — For φ 63 [2.480in.]
- 80 — For φ 80 [3.150in.]
- 100 — For φ 100 [3.940in.]
- 125 — For φ 125 [4.921in.]

● Y, I type knuckle



Cylinder type

- NDDA — DYNA cylinder
- NDDAL — DYNA non-rotating cylinder

Knuckles

- Y — Y type knuckle
- I — I type knuckle

● For dimensions of knuckle, see p.537.

Bore size

- 32 — For φ 32 [1.260in.]
- 40 — For φ 40 [1.575in.]
- 50 — For φ 50 [1.969in.]
- 63 — For φ 63 [2.480in.]
- 80 — For φ 80 [3.150in.]
- 100 — For φ 100 [3.940in.]
- 125 — For φ 125 [4.921in.]

Maximum Available Stroke of Cylinder with Bellows

Bellows model / Bore size	mm [in.]	
	φ 32 [1.260]~φ 63 [2.480]	φ 80 [3.150]~φ 125 [4.921]
JT	Maximum available St×3/4-50	Maximum available St×4/5-50
JC	Maximum available St×3/4-50	Maximum available St×4/5-50
JK	Maximum available St×2/3-50	Maximum available St×2/3-50
JA	Maximum available St×2/3-50	Maximum available St×2/3-50