

High-quality stainless steel cylinders ahead of all others

SLIM CYLINDERS

Use durable piston seals.

The two piston seals are the durable PPY type. This prevents inner air leakage, and achieves smooth operation from low-speed to high-speed ranges.

Sensor switches can be installed anytime after cylinder installation.

Magnets as standard equipment across the entire series allow sensor switches to be installed anytime after the cylinder has been installed.

High installation accuracy and simple mounting operations.

A centering location on the rod cover improves mounting precision. Moreover, the mounting nut's improved thread precision means that holding the cylinder body in place by hand is sufficient for mounting nut tightening operations. Mounting in hard-to-reach places is easy.

Criteria for Selection: Slim Cylinder Allowable Kinetic Energy

Slim cylinders (with the exception of heat resistant specifications) include a cushioning mechanism.

This mechanism is intended to reduce as much as possible the impact of pistons with high kinetic energy when they stop at the end of the stroke. There are two types of cushions, as shown below.

● Rubber bumpers (Standard equipment)

Rubber bumpers installed on both sides of the piston soften the impact at the end of the stroke, and absorb the impact noise during stopping, in response to high-frequency and high-speed operations. They are standard equipment across the whole series, with the exception of heat resistant specifications.

Note that a certain amount of rebound will occur at the end of the stroke on the cylinder with the rubber bumpers.

● Variable cushions

Use variable cushions for large load or high-speed operations that rubber bumpers cannot adequately absorb. The impact is absorbed by compressing air, when the piston stops at the end of the stroke.

Since the cushioning stroke is included within the cylinder stroke, be careful to ensure that the cushion is not excessively performed during cylinder applications of 25mm strokes or less. An excessively performed cushion can result in too much time for each stroke, reducing efficiency. When operated at or below the absorbable kinetic energy shown in the table below, the cushion seal life is 1 million operations or more.

The load kinetic energy can be obtained through the formulas shown below.

$$E_x = \frac{m}{2} v^2$$

Ex: Kinetic energy (J)
m: Load mass (kg)
v: Piston speed (m/s)

$$E'_x = \frac{W}{2g} v'^2$$

E'x: Kinetic energy [ft·lbf]
W: Load [lbf.]
v': Piston speed [ft./sec.]
g: Acceleration of gravity 32.2 [ft./sec.²]

Operating speed range

- Rubber bumper 30~800mm/s [1.2~31.5in./sec.]
- Variable cushion 30~1000mm/s [1.2~39.4in./sec.]

Bore size mm [in.]	Allowable kinetic energy J [ft·lbf]	
	With rubber bumpers	With variable cushion
16 [0.630]	0.07 [0.052]	0.18 [0.13]
20 [0.787]	0.27 [0.20]	0.7 [0.52]
25 [0.984]	0.40 [0.30]	1.05 [0.77]
32 [1.260]	0.65 [0.48]	1.8 [1.33]
40 [1.575]	1.2 [0.89]	2.8 [2.07]
50 [1.969]	—	3.5 [2.58]
63 [2.480]	—	4.5 [3.32]

Rubber bumper (Graph 1)



Variable cushion (Graph 2)

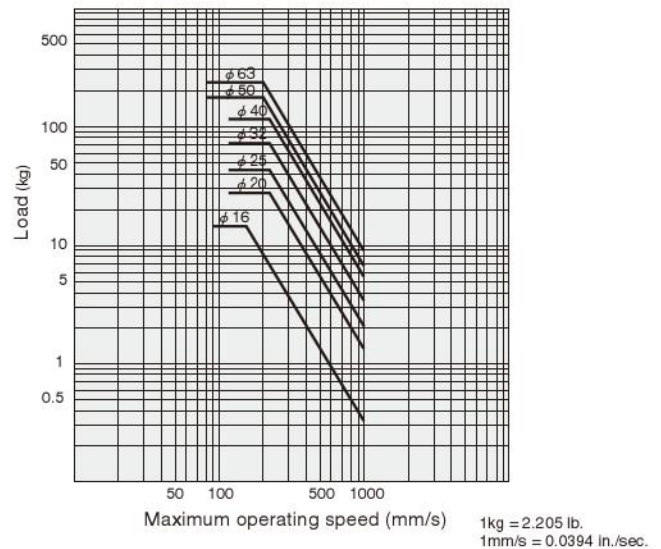

How to read the graphs

From Graph 1, the capacity of the rubber bumpers limits the maximum speed to 500mm/s [19.7in./sec.] or less when a φ32 Slim Cylinder is used to carry a load of 5kg [11.0lb.].

From Graph 2, a φ32 cylinder with variable cushion can be selected to carry a load of 8kg [17.6lb.] at a maximum speed of 600mm/s [23.6in./sec.].

SLIM BRAKE CYLINDERS

Symbol

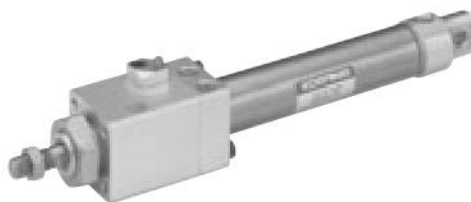
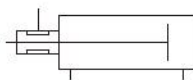

Specifications

Item		Bore size mm [in.]	20 [0.787]	25 [0.984]	32 [1.260]	40 [1.575]
Media			Air			
Proof pressure		MPa [psi.]	1.32 [191]			
Operating temperature range		°C [°F]	5~60 [41~140]			
Operating speed range		mm/s [in./sec.]	50~500 [2.0~19.7]			
Cylinder section	Operation type		Double acting type			
	Mounting type		Basic type, Foot type, Flange type, Pivot type, Head trunnion type			
	Operating pressure range	MPa [psi.]	0.08~0.9 [12~131]			
	Cushion		Fixed type (Rubber bumper)			
	Lubrication		Not required			
	Port size	Rc	1/8			
Brake section	Operation type		Spring, spring assisted air pressure type ^{Note1}			
	Operating pressure range (When air is applied to brake port)	MPa [psi.]	0.3~0.9 [44~131] (0.34~0.5 [49~73])			
	Lubrication		Prohibited ^{Note2}			
	Retaining force (When pneumatic lock is pressurized to 0.4Mpa. [58psi.])	N [lbf.]	156.9 [35.27] (245.2 [55.12])	245.2 [55.12] (392.3 [88.19])	392.3 [88.19] (617.8 [138.9])	617.8 [138.9] (980.7 [220.5])
	Allowable kinetic energy of lock	J [ft·lbf]	0.265 [0.195]	0.422 [0.311]	0.696 [0.513]	1.187 [0.875]
	Repeatability (When air is applied to brake port)	mm [in.]	±1 [0.039] (±0.5 [0.020]) ^{Note3}			
Port size	Rc	1/8				

Notes: 1. The body is for common use. For details, see the Handling Instructions and Precautions on p.369.

2. Do not use lubrication.

3. For the case where cylinder speed is 300mm [11.8in./sec.], pressure is 0.5MPa [73psi.], and the load ratio is 25%. For details, see the Handling Instructions and Precautions on p.369.

Bore Size and Strokes

Bore size	Standard strokes	Maximum stroke		Maximum available stroke	
		No bellows	With bellows	No bellows	With bellows
		20	25 50 75 100 125 150		200
25	25 50 75 100 125 150 200		250		
32	25 50 75 100 125 150 200		300	1050	740
40	25 50 75 100 125 150 200 250 300	400	300		

Remarks: 1. Stroke tolerance $^{+1}_0$ [$^{+0.039}_{0}$ in.]

2. For non-standard strokes, consult us.

3. The minimum operating pressure when the stroke is over the maximum stroke is 0.2MPa [29psi.].

Order Codes

DA R 20×50 — — — — — — — — —

Slim double acting cylinder
DA — Bellows
Blank — No bellows
J — With bellows (Made to order)
R — Brake cylinder
20×50 — Bore size × Stroke
 — Rod end accessory
Blank — No rod end accessory
I — I type knuckle
Y — Y type knuckle (with pin)
● For the cylinder joint and cylinder rod end, see p.1568.
 — Mounting type
Blank — Basic type
1 — Foot mounting type
3 — Flange mounting type
8E — Pivot mounting type with supporting bracket (with pin)
11 — Head trunnion type
11-11T — Head trunnion type with supporting bracket
● Mounting brackets are included at shipping.
 — Head cover specification
Blank — Standard head
A — Short head
 — Number of sensor switches
1 — With 1 sensor switch
2 — With 2 sensor switches
3 — With 3 sensor switches
⋮ —
 — Lead wire length (Applies to all except **CS□F**)
A — 1000mm [39in.]
B — 3000mm [118in.]
Sensor switch (for cylinders with sensor switches)
Blank — No sensor switch
ZG530 — 2-lead wire Solid state type with indicator lamp DC10~28V
ZG553 — 3-lead wire Solid state type with indicator lamp DC4.5~28V
CS3M — Reed switch type with indicator lamp DC10~30V
CS4M — Reed switch type with indicator lamp AC85~230V
CS5M — Reed switch type without indicator lamp DC10~30V
CS2F — Reed switch type with indicator lamp AC85~115V
CS3F — Reed switch type with indicator lamp DC3~30V
CS4F — Reed switch type with indicator lamp AC85~115V
CS5F — Reed switch type without indicator lamp AC85~230V
● For details of sensor switches, see p.1544.
● CS□F comes with DIN connector. All others are grommet type.

Inner Construction (cannot be disassembled)

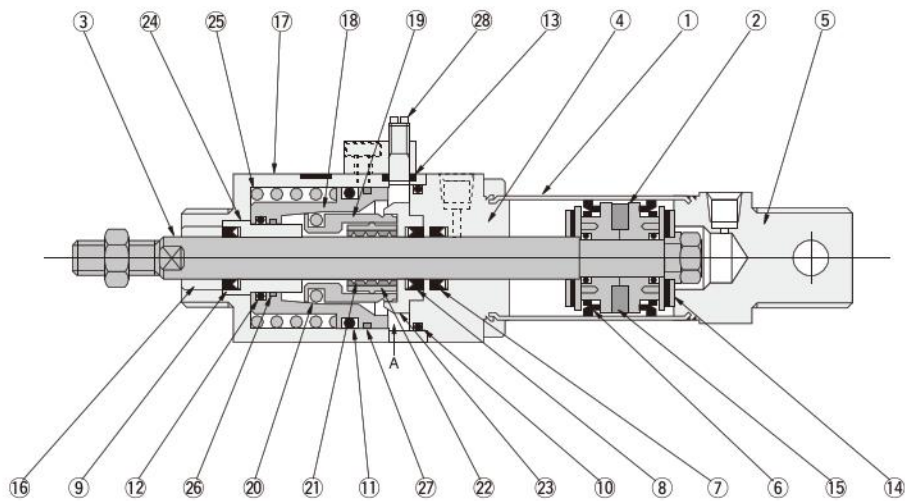

The diagram shows the brake release state.

Major Parts and Materials

No.	Parts	Materials
①	Cylinder tube	Stainless steel
②	Piston	Plastic
③	Piston rod	Steel (hard chrome plated)
④	Rod cover	Aluminum (anodized)
⑤	Head cover	
⑥	Piston seal	Synthetic rubber (NBR)
⑦~⑨	Rod seal	
⑩~⑬	O-ring	
⑭	Bumper	
⑮	Magnet	Plastic magnet
⑯	Rod bushing	Oil impregnated bronze sintered alloy
⑰	Brake head	Aluminum (anodized)
⑱	Brake piston	Special steel (heat-treated)
⑲	Collet	
⑳	Steel ball	High carbon steel
㉑	Brake shoe	Special brake lining (copper sintered material)
㉒	Brake shoe holder	Special steel (heat-treated)
㉓	Holder	
㉔	Guide	Aluminum alloy
㉕	Spring	Piano wire (zinc plated)
㉖~㉗	Wear ring	Plastic
㉘	Brake release screw	Mild steel (zinc plated)
	Bellows	Nylon tarpaulin (heat resistant temperature 60°C)

Operating Principle

Brake operation

When air is exhausted from chamber A, brake piston ⑱ is moved by spring ㉕ to the right, steel ball ⑳ in contact with the tapered section inside of brake piston ⑱ is pushed to the inner side, and collet ⑲ works as a lever with holder ㉓ and brake shoe holder ㉒ as a pivot point. This action presses brake shoe ㉑ to tighten the piston rod and activate the brake.

Brake release

When air is supplied to chamber A, brake piston ⑱ moves to the left against spring ㉕, steel ball ⑳ is separated from the tapered section inside of brake piston ⑱, and collet ⑲ expands and brake shoe ㉑ spreads to release the piston rod and disengage the brake.

Seals

Note: Seals cannot be replaced.

Parts	Rod seal ⑦~⑨	Piston seal ⑥	O-ring ⑩	O-ring ⑪	O-ring ⑫	O-ring ⑬
Quantity	3	2	1	1	1	1
Bore						
20	NY-12×8×3.5	PPY-20	L090102	P21	P12	P5
25	NY-14×10×3.5	PPY-25	S26	P24	P14	P5
32	NY-17×12×4	PPY-32	S34	P32	P18	P6
40	NY-22×16×5	PPY-40	S42	P40	P22	P6

Mass

Bore size mm [in.]	Zero stroke mass			Additional mass for each 1mm [0.0394in.] stroke	Mass of mounting bracket		
	Standard head type	Short head type	Trunnion type		Foot mounting type	Flange mounting type	Clevis mounting type
20 [0.787]	0.37 [0.82]	0.36 [0.79]	0.56 [1.23]	0.0008 [0.0018]	0.14 [0.31]	0.08 [0.18]	0.06 [0.13]
25 [0.984]	0.54 [1.19]	0.53 [1.17]	0.72 [1.59]	0.0011 [0.0024]	0.16 [0.35]	0.08 [0.18]	0.06 [0.13]
32 [1.260]	0.84 [1.85]	0.82 [1.81]	1.01 [2.23]	0.0015 [0.0033]	0.19 [0.42]	0.10 [0.22]	0.14 [0.31]
40 [1.575]	1.30 [2.87]	1.28 [2.82]	1.48 [3.26]	0.0024 [0.0053]	0.29 [0.64]	0.13 [0.29]	0.14 [0.31]

kg [lb.]

Dimensions of Brake Cylinder Basic Type (mm)

DAR Bore size × Stroke

CAD DAR- Bore size

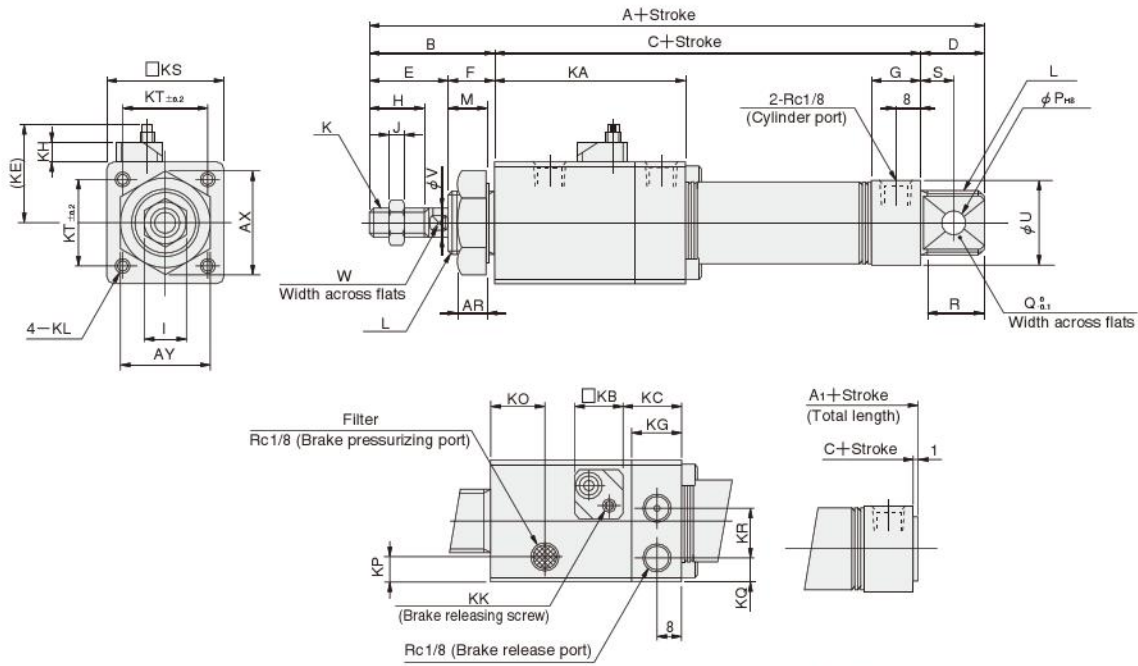

Brake head section

● Short head

DAR Bore size × Stroke -A

CAD SLIM-A

Bore mm [in.]	Code	A	A ₁	B	C	D	E	F	G	H	I	J	K	L	M	P	Q	R	S	U	V	W	AR	AX	AY
20	[0.787]	175	155	35	119	21	23	12	16	15	12	5	M8×1	M20×1.5	10	8	12	19	12	27	8	6	7.5	31.2	27
25	[0.984]	184	164	40	123	21	26	14	16	18	14	6	M10×1.25	M22×1.5	12	8	12	19	12	29	10	8	9.5	34.6	30
32	[1.260]	202	176	45	130	27	31	14	16	23	14	6	M10×1.25	M27×2	12	10	20	25	15	35	12	10	9.5	41.6	36
40	[1.575]	217	191	45	145	27	31	14	(14.5)	23	19	8	M14×1.5	M33×2	12	10	20	25	15	41.6	16	14	9.5	47.3	41

Bore mm [in.]	Code	KA	KB	KC	KE	KG	KH	(KK)	KL	KO	KP	KQ	KR	KS	KT
20	[0.787]	59	16	19	29	16	6.5	M5×0.8	M5×0.8 Depth7	16.5	7	7	14.5	35	26
25	[0.984]	63	16	19.5	32	16	6.5	M5×0.8	M5×0.8 Depth9	18	8	8	16	40	28
32	[1.260]	70	20	19	38	16	9	M6×1	M5×0.8 Depth9	23	8	14.5	16	45	34
40	[1.575]	83	20	20	40	16	9	M6×1	M6×1 Depth10	27	9	18	16	52	40

Dimensions of Brake Cylinder Foot Mounting Type (mm)

DAR Bore size × Stroke -1

CAD DAR- Bore size SLIM-F01

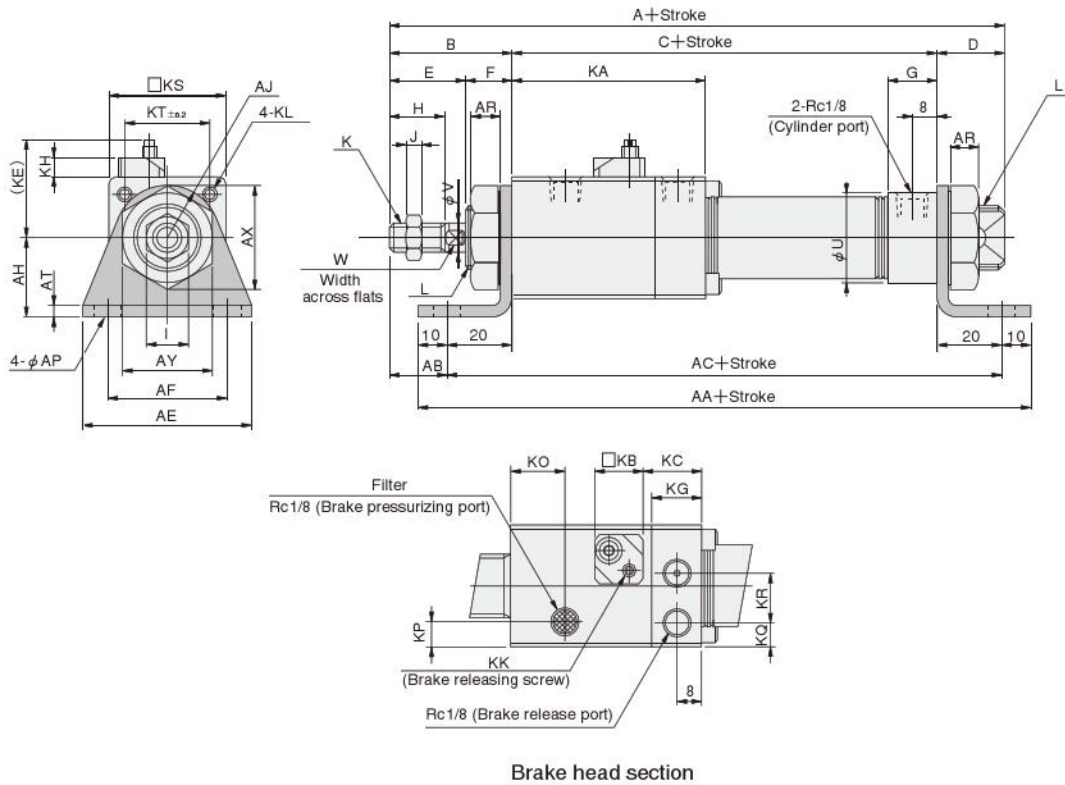

SLIM CYLINDERS

Bore mm [in.]	Code	A	B	C	D	E	F	G	H	I	J	K	L	U	V	W
20	[0.787]	175	35	119	21	23	12	16	15	12	5	M8×1	M20×1.5	27	8	6
25	[0.984]	184	40	123	21	26	14	16	18	14	6	M10×1.25	M22×1.5	29	10	8
32	[1.260]	202	45	130	27	31	14	16	23	14	6	M10×1.25	M27×2	35	12	10
40	[1.575]	217	45	145	27	31	14	(14.5)	23	19	8	M14×1.5	M33×2	41.6	16	14

Bore mm [in.]	Code	KA	KB	KC	KE	KG	KH	(KK)	KL	KO	KP	KQ	KR	KS	KT
20	[0.787]	59	16	19	29	16	6.5	M5×0.8	M5×0.8 Depth7	16.5	7	7	14.5	35	26
25	[0.984]	63	16	19.5	32	16	6.5	M5×0.8	M5×0.8 Depth9	18	8	8	16	40	28
32	[1.260]	70	20	19	38	16	9	M6×1	M5×0.8 Depth9	23	8	14.5	16	45	34
40	[1.575]	83	20	20	40	16	9	M6×1	M6×1 Depth10	27	9	18	16	52	40

Bore mm [in.]	Code	AA	AB	AC	AE	AF	AH	AJ	AP	AR	AT	AX	AY
20	[0.787]	179	15	159	55	40	25	15.5	6.8	7.5	3.2	31.2	27
25	[0.984]	183	20	163	55	40	30	17	6.8	9.5	3.2	34.6	30
32	[1.260]	190	25	170	55	40	35	20	6.8	9.5	3.2	41.6	36
40	[1.575]	205	25	185	75	55	40	23.5	9	9.5	4	47.3	41

Dimensions of Brake Cylinder Flange Mounting Type (mm)

● $\phi 20 \sim \phi 25$ DAR × -3

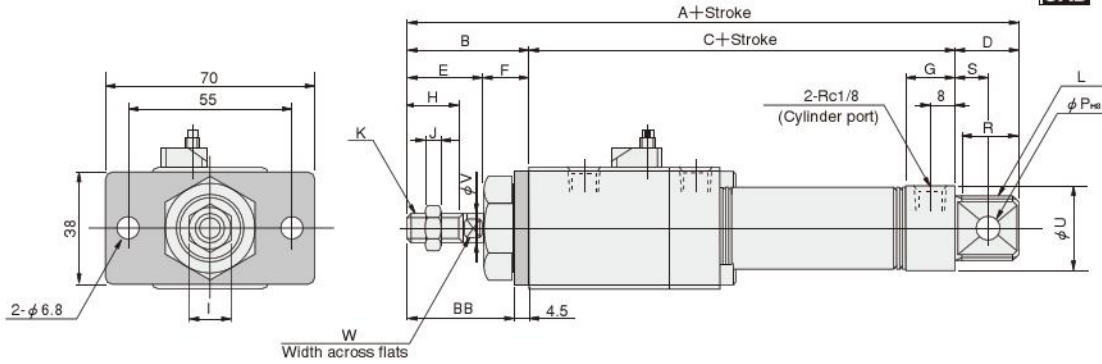

● $\phi 32 \sim \phi 40$

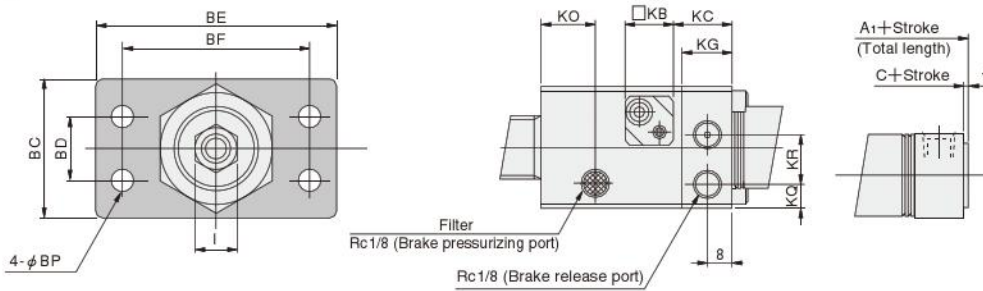

Brake head section ● Short head

DAR × -A-3



Bore mm [in.]	Code	A	A ₁	B	C	D	E	F	G	H	I	J	K	L	P	R	S	U	V	W
20	[0.787]	175	155	35	119	21	23	12	16	15	12	5	M8×1	M20×1.5	8	19	12	27	8	6
25	[0.984]	184	164	40	123	21	26	14	16	18	14	6	M10×1.25	M22×1.5	8	19	12	29	10	8
32	[1.260]	202	176	45	130	27	31	14	16	23	14	6	M10×1.25	M27×2	10	25	15	35	12	10
40	[1.575]	217	191	45	145	27	31	14	(14.5)	23	19	8	M14×1.5	M33×2	10	25	15	41.6	16	14

Bore mm [in.]	Code	BB	BC	BD	BE	BF	BP	KQ	KR	KO	KB	KC	KG
20	[0.787]	30.5	—	—	—	—	—	7	14.5	16.5	16	19	16
25	[0.984]	35.5	—	—	—	—	—	8	16	18	16	19.5	16
32	[1.260]	40.5	45	20	80	60	6.8	14.5	16	23	20	19	16
40	[1.575]	40.5	50	30	100	80	9	18	16	27	20	20	16

Dimensions of Brake Cylinder Pivot Mounting Type (mm)

DAR × -8E

 DAR- SLIM-CL7

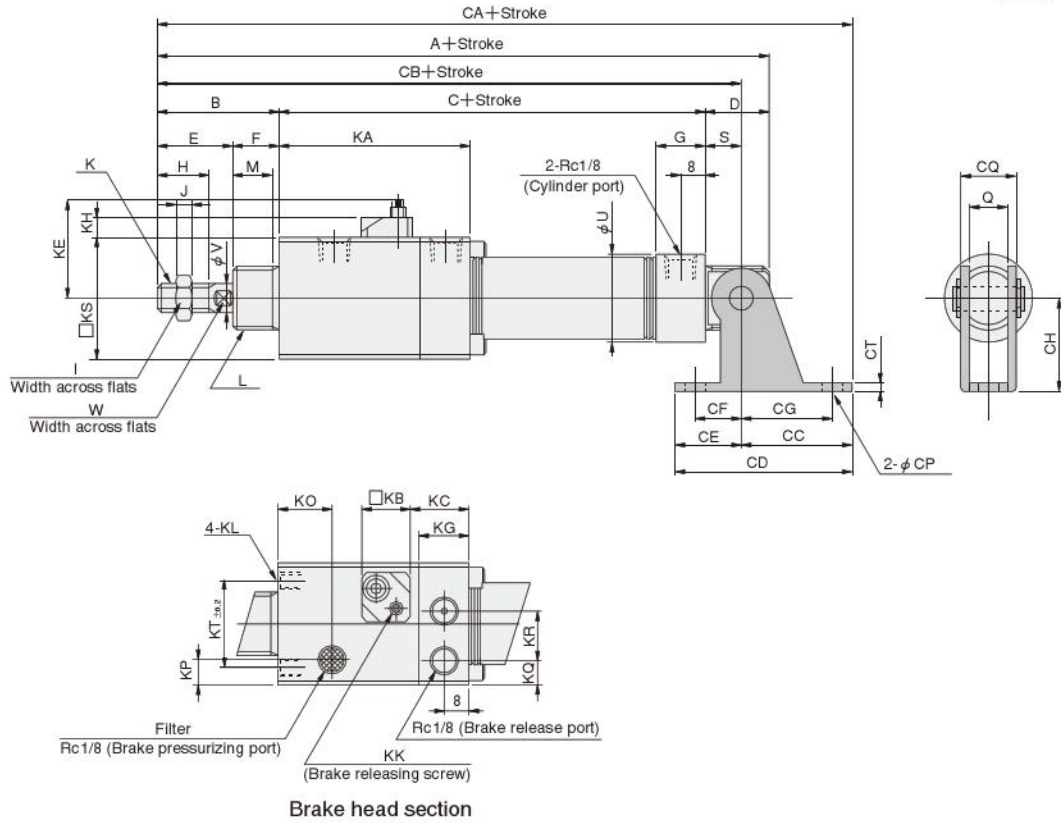

SLIM CYLINDERS

Bore mm [in.]	Code	A	B	C	D	E	F	G	H	I	J	K	L	M	Q	S	U	V	W
20	[0.787]	175	35	119	21	23	12	16	15	12	5	M8×1	M20×1.5	10	12	12	27	8	6
25	[0.984]	184	40	123	21	26	14	16	18	14	6	M10×1.25	M22×1.5	12	12	12	29	10	8
32	[1.260]	202	45	130	27	31	14	16	23	14	6	M10×1.25	M27×2	12	20	15	35	12	10
40	[1.575]	217	45	145	27	31	14	(14.5)	23	19	8	M14×1.5	M33×2	12	20	15	41.6	16	14

Bore mm [in.]	Code	KA	KB	KC	KE	KG	KH	(KK)	KL	KO	KP	KQ	KR	KS	KT
20	[0.787]	59	16	19	29	16	6.5	M5×0.8	M5×0.8 Depth7	16.5	7	7	14.5	35	26
25	[0.984]	63	16	19.5	32	16	6.5	M5×0.8	M5×0.8 Depth9	18	8	8	16	40	28
32	[1.260]	70	20	19	38	16	9	M6×1	M5×0.8 Depth9	23	8	14.5	16	45	34
40	[1.575]	83	20	20	40	16	9	M6×1	M6×1 Depth10	27	9	18	16	52	40

Bore mm [in.]	Code	CA	CB	CC	CD	CE	CF	CG	CH	CP	CQ	CT
20	[0.787]	203	166	37	59	22	15	30	30	6.8	18.4	3.2
25	[0.984]	212	175	37	59	22	15	30	30	6.8	18.4	3.2
32	[1.260]	240	190	50	75	25	15	40	40	9	28	4
40	[1.575]	255	205	50	75	25	15	40	40	9	28	4

Dimensions of Brake Cylinder Head Trunnion Type (mm)

DAR Bore size × Stroke -11-11T

 DAR- Bore size
SLIM-TR

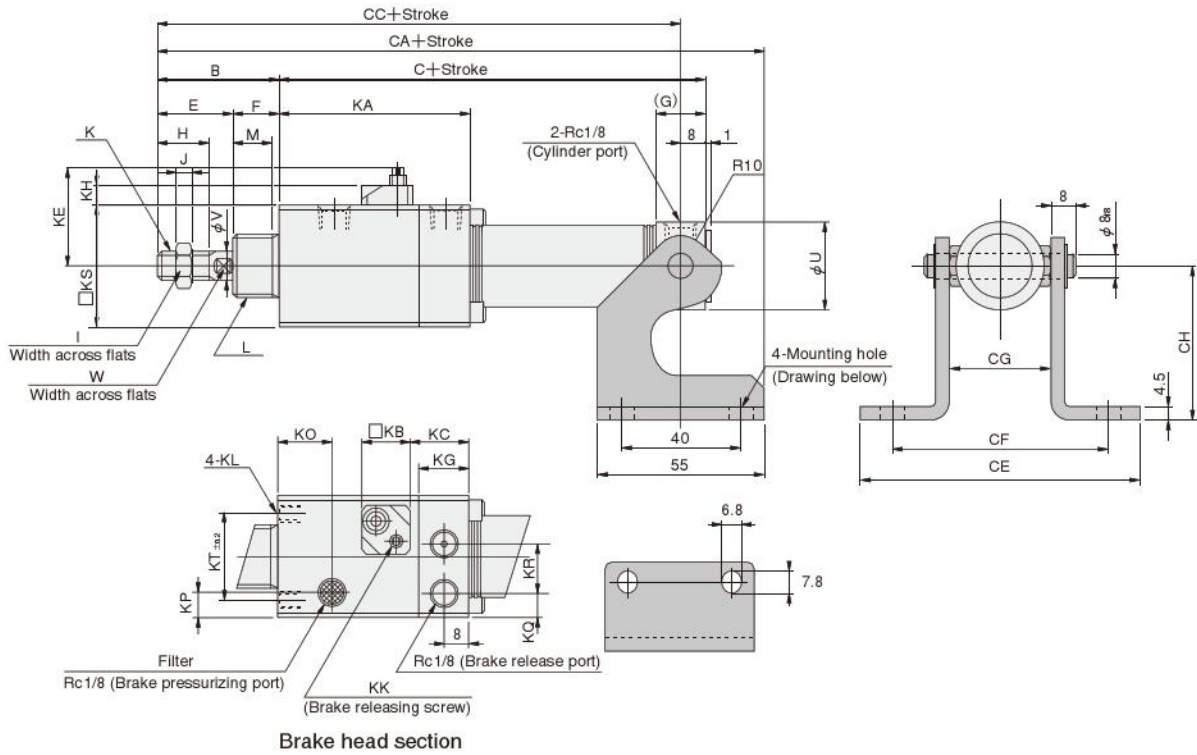

Bore mm (in.)	Code	B	C	E	F	G	H	I	J	K	L	M	U	V	W
	20 [0.787]	35	119	23	12	16	15	12	5	M8×1	M20×1.5	10	27	8	6
	25 [0.984]	40	123	26	14	16	18	14	6	M10×1.25	M22×1.5	12	29	10	8
	32 [1.260]	45	130	31	14	16	23	14	6	M10×1.25	M27×2	12	35	12	10
	40 [1.575]	45	145	31	14	(14.5)	23	19	8	M14×1.5	M33×2	12	41.6	16	14

Bore mm (in.)	Code	KA	KB	KC	KE	KG	KH	(KK)	KL	KO	KP	KQ	KR	KS	KT
	20 [0.787]	59	16	19	29	16	6.5	M5×0.8	M5×0.8 Depth7	16.5	7	7	14.5	35	26
	25 [0.984]	63	16	19.5	32	16	6.5	M5×0.8	M5×0.8 Depth9	18	8	8	16	40	28
	32 [1.260]	70	20	19	38	16	9	M6×1	M5×0.8 Depth9	23	8	14.5	16	45	34
	40 [1.575]	83	20	20	40	16	9	M6×1	M6×1 Depth10	27	9	18	16	52	40

Bore mm (in.)	Code	CA	CE	CF	CG	CH	CC
	20 [0.787]	173.5	92	72	32	50	146
	25 [0.984]	182.5	94	74	34	50	155
	32 [1.260]	194.5	100	80	40	50	167
	40 [1.575]	209.5	107	87	47	50	182

Dimensions of Brake Cylinder with Bellows (mm)

 SLIM-J

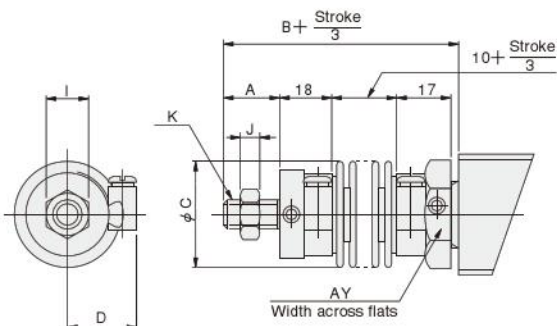

Bore mm (in.)	Code	A	B	C	D	AY	I	J	K
	20 [0.787]	15	63	35	23	27	12	5	M8×1
	25 [0.984]	18	66	35	23	30	14	6	M10×1.25
	32 [1.260]	23	71	40	26	36	14	6	M10×1.25
	40 [1.575]	23	71	48	29	41	19	8	M14×1.5



Mounting and piping

Control circuit

Electric control

When using a sequencer for control, the scanning time of the sequencer will affect the stopping position error. To improve the stopping position accuracy, use a TTL circuit, etc., to directly control the signal from the cylinder's sensor switch, and operate the valve.

Pneumatic circuit

- To achieve a balance with the load, and a balance of differences in rod diameter area, always use a regulator with check valve. Regulators we recommend include the F.R.L. multi series **R152**, the manifold regulator **MR102**, or the solenoid valve 180 series sub-base regulator -54 (for single unit order code: **M020014**).
- For the cylinder control solenoid valve (V1), use a pressure center type 3-position solenoid valve (**113-4E2-14**, **183-4E2-14**), etc.
- Install the solenoid valve for brake (V2) as close to the cylinder as possible. Moreover, using a DC current solenoid valve will improve response (repeatability).

Standard circuit

● Horizontal mounting Spring lock

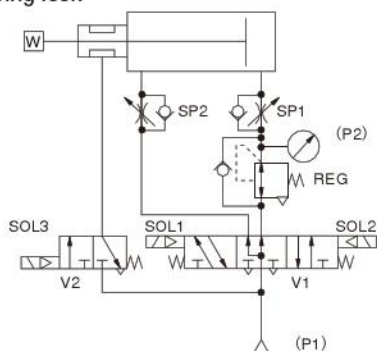

Spring assisted air pressure lock

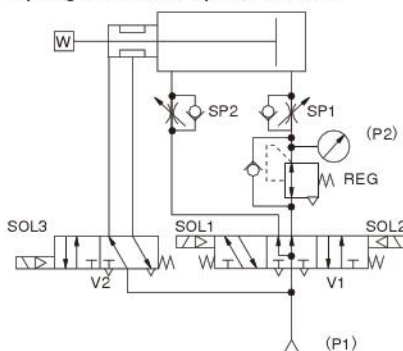

Regulator pressure setting

$$P2 = \frac{D^2 - d^2}{D^2} \cdot P1$$

D : Cylinder bore (mm)
d : Rod diameter (mm)
P1 : Supply pressure (MPa)

$$P2' = \frac{D'^2 - d'^2}{D'^2} \cdot P1'$$

D' : Cylinder bore [in.]
d' : Rod diameter [in.]
P1' : Supply pressure [psi.]

● Vertical mounting Spring lock

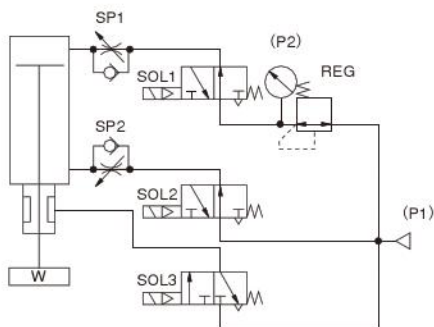

Spring assisted air pressure lock

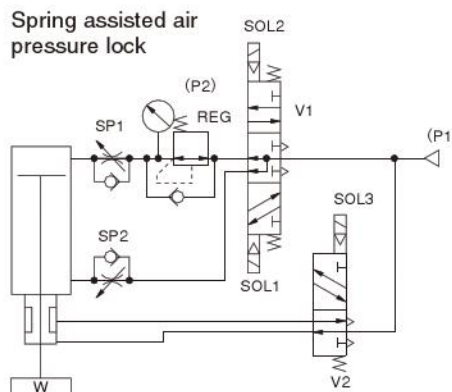

Regulator pressure setting

$$P2 = \frac{\pi (D^2 - d^2) P1 - 4W}{\pi \cdot D^2}$$

D : Cylinder bore (mm)
d : Rod diameter (mm)
P1 : Supply pressure (MPa)
W : Load (N)

$$P2' = \frac{\pi (D'^2 - d'^2) P1' - 4W'}{\pi \cdot D'^2}$$

D' : Cylinder bore [in.]
d' : Rod diameter [in.]
P1' : Supply pressure [psi.]
W' : Load [lbf]

● Vertical mounting (push up) spring assisted air pressure lock

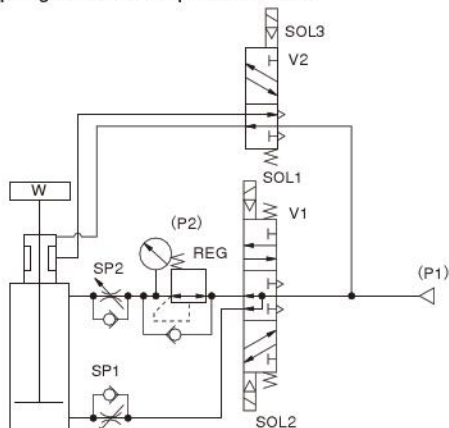

Regulator pressure setting

$$P2 = \frac{\pi \cdot D^2 \cdot P1 - 4W}{\pi (D^2 - d^2)}$$

D : Cylinder bore (mm)
d : Rod diameter (mm)
P : Supply pressure (MPa)
W : Load (N)

$$P2' = \frac{\pi \cdot D'^2 \cdot P1' - 4W'}{\pi (D'^2 - d'^2)}$$

D' : Cylinder bore [in.]
d' : Rod diameter [in.]
P' : Supply pressure [psi.]
W' : Load [lbf]

Solenoid ON, OFF switching sequence (same for all applications)

Valve Operating status	V1			V2
	SOL1	SOL2	SOL3	
Intermediate stop	OFF	OFF	OFF	
Extend	OFF	ON	ON	
Retract	ON	OFF	ON	

Handling Instructions and Precautions



Mounting and piping

Brake mechanism

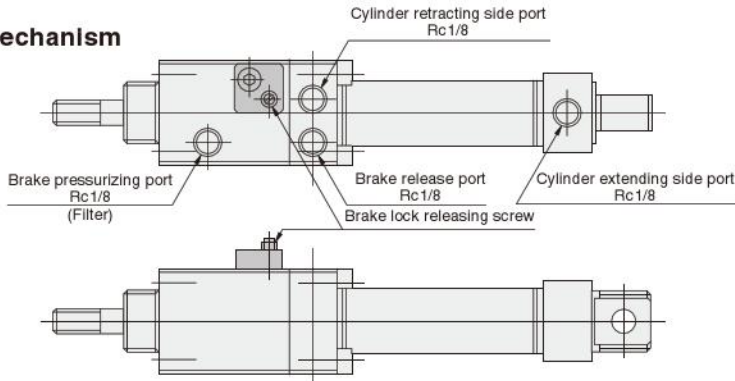

Manual operation

- **Brake release**
Apply 0.3~0.9MPa [44~131psi.] air pressure to the brake release port, then use a small screwdriver, etc., to thread the brake lock releasing screw in the clockwise direction until the screw thread disappears.
- **Brake operation**
To again operate the brake, apply 0.3~0.9MPa [44~131psi.] air pressure to the brake release port, then use a small screwdriver, etc., to return the brake lock releasing screw in the counterclockwise direction until the screw comes to a stop.
- **Brake release**
For safety, the brake lock releasing screw is designed to be immovable if no air has been applied to the brake release port.

Spring assisted air pressure lock

- To increase the holding force, use a screwdriver, etc., to remove the filter on the brake pressurizing port and use it as a connection port for spring assisted air pressure type brake.
- While using a spring assisted air pressure brake will approximately double the holding force, too much pressure on the brake pressurizing port could reduce the durability of the brake mechanism. For this reason, always maintain air pressure in the pressurizing port within a range of 0.34~0.50MPa [49~73psi.] when using a 4 way valve to switch between the brake release port and the pressurizing port.

Stopping position accuracy

1. Stopping position accuracy (repeatability) shown in the specifications table is for initial conditions. This can change over time as the piston rod grease deteriorates, and as wear on the brake shoe and piston rod progresses.
 2. The stopping position accuracy can vary in accordance with cylinder speed, control circuit delay time (sequencer scanning time, etc.), fluctuation in brake valve (V2) operating time, piping length, and piping diameter, etc.
 3. To improve the stopping position accuracy, install a pressure reducing valve to ensure there are no pressure fluctuations in the media.
 4. Use the brake cylinder within the allowable kinetic energy range.
- Fluctuations in cylinder stopping time arising during the sequencer's scanning time (or circuit operating time).
 - Allowable kinetic energy when locked

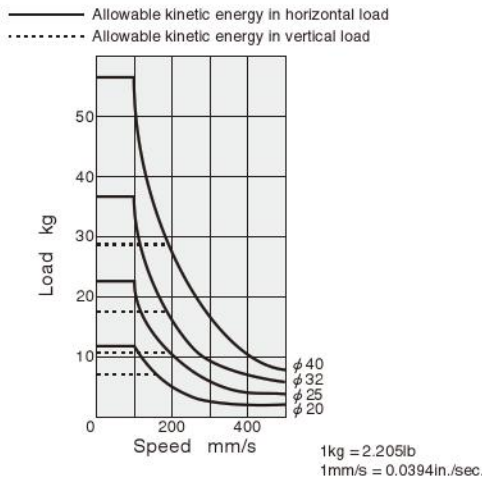
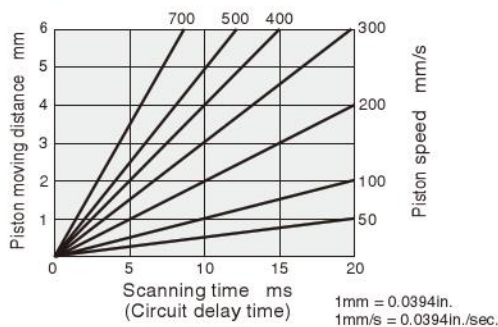

- Examples: 1. A brake cylinder operated at a scanning time of 10ms (which will vary according to the sequencer and the number of program steps) and a cylinder speed of 300mm/s [11.8in./sec.] will cause a fluctuation of 3mm [0.118in.].
2. When 10ms is required for the response time of relays, etc., at least 3mm [0.118in.] of operating distance is required for the sensor. (When the cylinder speed is 300mm/s [11.8 in./sec.]

Note: Use the brake cylinder within the allowable kinetic energy range.

Handling Instructions and Precautions



Sensor switch mounting location

For moving sensor switch, see p.419.
Since dimensions for the mounting location will vary, see the table below.

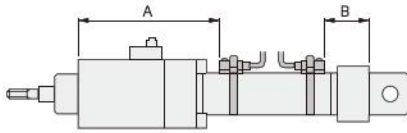

● Mounting location of end of stroke detection sensor switch

Sensor switch model	Bore size mm [in.]	20	25	32	40
		[0.787]	[0.984]	[1.260]	[1.575]
ZG530□	A	70 [2.756]	74 [2.913]	81 [3.189]	95 [3.740]
	B	27 [1.063]	27 [1.063]	27 [1.063]	27 [1.063]
ZG553□	A	70 [2.756]	74 [2.913]	81 [3.189]	95 [3.740]
	B	27 [1.063]	27 [1.063]	27 [1.063]	27 [1.063]
CS□M	A	70 [2.756]	74 [2.913]	81 [3.189]	95 [3.740]
	B	27 [1.063]	27 [1.063]	27 [1.063]	27 [1.063]
CS□F	A	65 [2.559]	69 [2.717]	76 [2.992]	90 [3.543]
	B	22 [0.866]	22 [0.866]	22 [0.866]	22 [0.866]



General precautions

Media

1. Air used in the brake cylinder should be clean air that contains no lubrication. Use of lubrication or humidified air could cause the grease inside the braking mechanism to wash out, which could later result in rapid wear on the braking mechanism caused by the consequent shortage of lubrication, etc.
2. Air used for the cylinder should be clean air that contains no deteriorated compressor oil, etc. Install an air filter (filtration of a minimum 40 μm) near the cylinder or valve to remove collected liquid or dust. In addition, drain the air filter periodically. Collected liquid or dust entering the cylinder may cause improper operation.

Maintenance

If the above basic precautions are observed, the brake cylinder can be used maintenance-free for a long period of time.

Atmosphere

1. If using in locations subject to dripping water, dripping oil, etc., or to large amounts of dust, use a cover to protect the unit.
2. The product cannot be used when the media or ambient atmosphere contains any of the substances listed below.
Organic solvents, phosphate ester type hydraulic oil, sulphur dioxide, chlorine gas, or acids, etc.

Application Examples

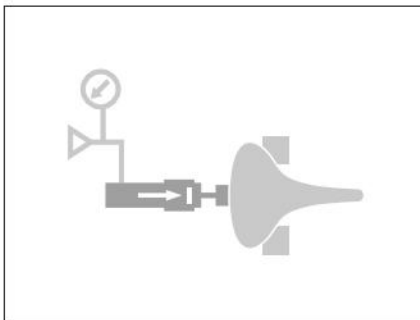

The piston rod locking

Use low pressure to press down cathode-ray tubes, etc., and then lock.

[To hold in place glass products, plastic, and other easily deformable items.]

- Cathode-ray tube manufacturing line
- Injection machine peripheral devices
- Tire production line

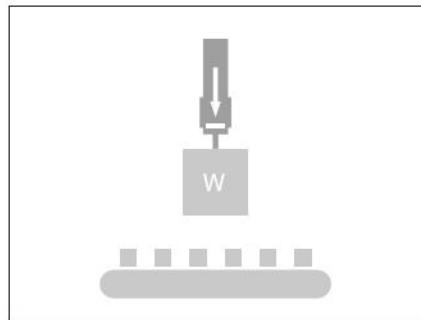

Prevention of falls in intermediate positions

The load is locked in place to prevent damage to work, etc., even when air pressure drops suddenly due to power failures, etc.

[Used for working operations which are set in intermediate positions.]

- Pick and place
- FMS (multi-item, small-lot production) conveyor line
- Automatic packaging machine

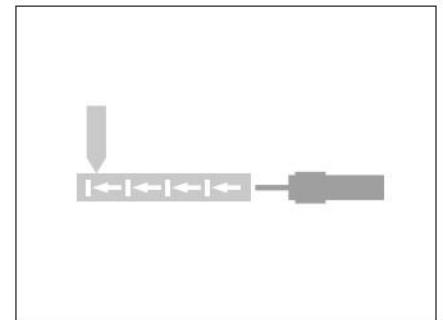

Multi-point operations

Spot welding at multiple points.

Workpiece switching

Select the products, and classify into several categories.

Fixture replacement

Move fixture to desired device.

- Spot welding machine
- Metal mold exchange
- Automatic chuck exchange

SENSOR SWITCHES

Solid State Type, Reed Switch Type

- Since a magnet is already standard on the Slim cylinders series^{Note}, mounting a sensor switch will enable use in sensor switch applications.

Note: Except the heat resistant specification cylinder.

Symbol



Order Codes

- Order codes for sensor switches mounted on the Slim cylinders

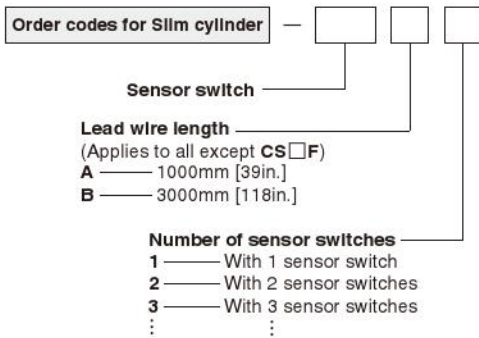

Sensor switch			
ZG530	Solid state type	For $\phi 16 \sim \phi 63$ with indicator lamp	DC10~30V
ZG553	Solid state type	For $\phi 16 \sim \phi 63$ with indicator lamp	DC4.5~28V
CS3M	Reed switch type	For $\phi 16 \sim \phi 63$ with indicator lamp	DC10~30V
CS4M	Reed switch type	For $\phi 16 \sim \phi 63$ with indicator lamp	AC85~230V
CS5M	Reed switch type	For $\phi 16 \sim \phi 63$ without indicator lamp	DC10~30V
CS2F	Reed switch type	For $\phi 20 \sim \phi 63$ with indicator lamp	AC85~115V
CS3F	Reed switch type	For $\phi 20 \sim \phi 63$ with indicator lamp	DC3~30V
CS4F	Reed switch type	For $\phi 20 \sim \phi 63$ with indicator lamp	AC85~115V
CS5F	Reed switch type	For $\phi 20 \sim \phi 63$ without indicator lamp	AC85~230V
			DC10~30V
			DC3~30V

- Order codes for sensor switch only

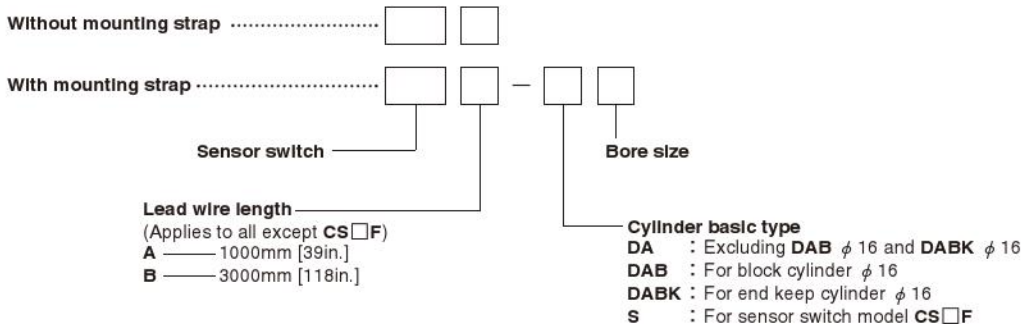

- Order codes for mounting strap only

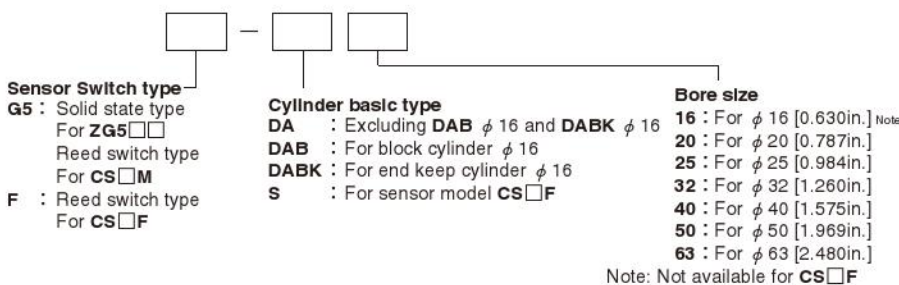

Minimum Cylinder Strokes When Using Sensor Switches

Sensor switch model	Bore size	2 pcs. mounting		1 pc. mounting
		mm		
		Along a straight line	In staggered positions	
ZG530	16	20	10	10
ZG553	20~63	20	10	10
CS□M	16~63	20	15	15
CS□F	20~63	40	21	15

● Two pieces mounting ● One piece mounting

● When mounted in-line

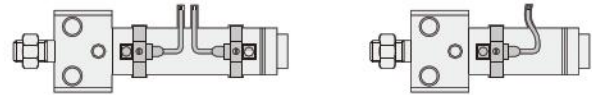

● When mounted in staggered positions

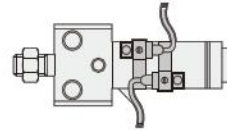

Sensor Switch Operating Range, Response Differential, and Maximum Sensing Location

● Operating range : ℓ

The distance the piston travels in one direction, while the switch is in the ON position.

● Response differential : C

The distance between the point where the piston turns the switch ON and the point where the switch is turned OFF as the piston travels in the opposite direction.

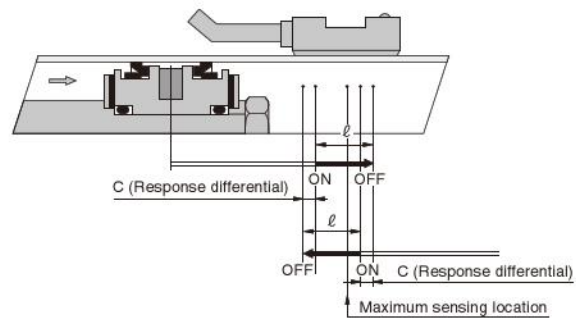

Item	Bore size	mm [in.]						
		16 [0.630]	20 [0.787]	25 [0.984]	32 [1.260]	40 [1.575]	50 [1.969]	63 [2.480]
Operating range : ℓ	ZG530□	2.5~4.1 [0.098~0.161]	2.5~4.2 [0.098~0.165]	2.6~4.3 [0.102~0.169]	3.0~4.8 [0.118~0.189]	3.1~5.0 [0.122~0.197]	3.3~5.4 [0.130~0.213]	3.5~5.7 [0.138~0.224]
	ZG553□	—	—	—	—	—	—	—
	CS□M	6.7~7 [0.264~0.276]	7~8.5 [0.276~0.335]	7~8.5 [0.276~0.335]	8~9 [0.315~0.354]	9~10.5 [0.354~0.413]	7~8 [0.276~0.315]	8~9.5 [0.315~0.374]
	CS□F	—	7~8.5 [0.276~0.335]	8.5~10 [0.335~0.394]	9~10.5 [0.354~0.413]	10.5~12 [0.413~0.472]	9~10 [0.354~0.394]	9~10.5 [0.354~0.413]
Response differential : C	ZG530	0.7 [0.028] or less	0.7 [0.028] or less	0.8 [0.031] or less	0.7 [0.028] or less	0.8 [0.031] or less	0.8 [0.031] or less	0.8 [0.031] or less
	ZG553	0.7 [0.028] or less	0.7 [0.028] or less	0.8 [0.031] or less	0.7 [0.028] or less	0.8 [0.031] or less	0.8 [0.031] or less	0.8 [0.031] or less
	CS□M	1 [0.039] or less	1 [0.039] or less	1 [0.039] or less	1 [0.039] or less	1 [0.039] or less	1.2 [0.047] or less	1.2 [0.047] or less
	CS□F	—	1.5 [0.059] or less	1.5 [0.059] or less	1.5 [0.059] or less	1.5 [0.059] or less	2 [0.079] or less	1.5 [0.059] or less
Maximum sensing location	ZG530, ZG553 ^{Note 1}	11 [0.433]	11 [0.433]	11 [0.433]	11 [0.433]	11 [0.433]	11 [0.433]	11 [0.433]
	CS□M ^{Note 1}	11 [0.433]	11 [0.433]	11 [0.433]	11 [0.433]	11 [0.433]	11 [0.433]	11 [0.433]
	CS□F ^{Note 2}	—	16 [0.630]	16 [0.630]	16 [0.630]	16 [0.630]	16 [0.630]	16 [0.630]

Remark: Figures in the table above are reference values.

Notes: 1. Figures are lengths measured from the switch's opposite end side to the lead wire.

2. Figures are lengths measured from the connector side's end surface to the lead wire.

Mounting Location of End of Stroke Detection Sensor Switch

When the sensor switch is mounted in the location shown in the diagram (figures in the table are reference values), the magnet comes to the sensor switch's maximum sensing location at the end of the stroke.

● Air cylinder, Low hydraulic cylinder, Valpack cylinder

● Air cylinder, Low hydraulic cylinder ● Valpack cylinder

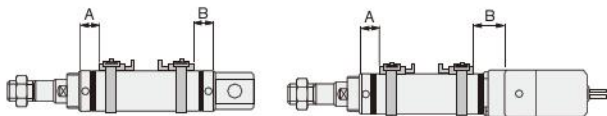

		mm [in.]									
Sensor switch model	Bore size Code	Air cylinder, Low hydraulic cylinder					Valpack cylinder				
		20	25	32	40	50	63	20	25	32	40
ZG530□ ZG553□	A	27 [1.063]	27 [1.063]	27 [1.063]	27 [1.063]	36 [1.417]	36 [1.417]	27 [1.063]	27 [1.063]	27 [1.063]	27 [1.063]
	B	27 [1.063]	27 [1.063]	27 [1.063]	27 [1.063]	36 [1.417]	36 [1.417]	39 [1.535]	39 [1.535]	39 [1.535]	44 [1.732]
CS□M	A	27 [1.063]	27 [1.063]	27 [1.063]	27 [1.063]	36 [1.417]	36 [1.417]	27 [1.063]	27 [1.063]	27 [1.063]	27 [1.063]
	B	27 [1.063]	27 [1.063]	27 [1.063]	27 [1.063]	36 [1.417]	36 [1.417]	39 [1.535]	39 [1.535]	39 [1.535]	44 [1.732]
CS□F	A	22 [0.866]	22 [0.866]	22 [0.866]	22 [0.866]	32 [1.260]	32 [1.260]	22 [0.866]	22 [0.866]	22 [0.866]	22 [0.866]
	B	22 [0.866]	22 [0.866]	22 [0.866]	22 [0.866]	32 [1.260]	32 [1.260]	34 [1.339]	34 [1.339]	34 [1.339]	39 [1.535]

● Single acting cylinder

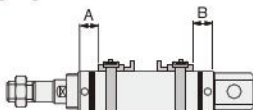

		mm [in.]				
Sensor switch model	Code	Stroke	Bore size			
			20 [0.787]	25 [0.984]	32 [1.260]	40 [1.575]
ZG530□ ZG553□ CS□M	A	0~25	35 [1.378]	36 [1.417]	35 [1.378]	37 [1.457]
		26~50	52 [2.047]	49 [1.929]	49 [1.929]	53 [2.087]
		51~75	72 [2.835]	71 [2.795]	72 [2.835]	68 [2.677]
		76~100	—	84 [3.307]	86 [3.386]	95 [3.740]
		101~125	—	—	—	110 [4.331]
		126~150	—	—	—	125 [4.921]
CS□F	A	0~25	30 [1.181]	31 [1.220]	30 [1.181]	32 [1.260]
		26~50	47 [1.850]	44 [1.732]	44 [1.732]	48 [1.890]
		51~75	67 [2.638]	66 [2.598]	67 [2.638]	63 [2.480]
		76~100	—	79 [3.110]	81 [3.189]	90 [3.543]
		101~125	—	—	—	105 [4.134]
		126~150	—	—	—	120 [4.724]
CS□F	B	—	22 [0.866]	22 [0.866]	22 [0.866]	22 [0.866]

● Block cylinder

● Side mount

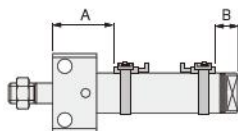

● Front mount

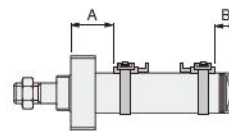

Mounting type		mm [in.]													
Bore size		Side mount					Front mount								
		16	20	25	32	40	50	63	16	20	25	32	40	50	63
ZG530□	A Rod side	32 [1.260]	39 [1.535]	41 [1.614]	47 [1.850]	57 [2.244]	67 [2.638]	67 [2.638]	23 [0.906]	27 [1.063]	27 [1.063]	27 [1.063]	29 [1.142]	37 [1.457]	37 [1.457]
ZG553□	B Rod side	16 [0.630]	20 [0.787]	20 [0.787]	21 [0.827]	25 [0.984]	45 [1.772]	45 [1.772]	16 [0.630]	20 [0.787]	20 [0.787]	21 [0.827]	25 [0.984]	45 [1.772]	45 [1.772]
CS□M	A Rod side	32 [1.260]	39 [1.535]	41 [1.614]	47 [1.850]	57 [2.244]	66 [2.598]	66 [2.598]	23 [0.906]	27 [1.063]	27 [1.063]	27 [1.063]	29 [1.142]	36 [1.417]	36 [1.417]
	B Rod side	16 [0.630]	20 [0.787]	20 [0.787]	21 [0.827]	25 [0.984]	44 [1.732]	44 [1.732]	16 [0.630]	20 [0.787]	20 [0.787]	21 [0.827]	25 [0.984]	44 [1.732]	44 [1.732]
CS□F	A Rod side	—	36 [1.417]	38 [1.496]	44 [1.732]	52 [2.047]	64 [2.520]	64 [2.520]	—	24 [0.945]	24 [0.945]	24 [0.945]	24 [0.945]	34 [1.339]	34 [1.339]
	B Rod side	—	17 [0.669]	17 [0.669]	18 [0.709]	20 [0.787]	42 [1.654]	42 [1.654]	—	17 [0.669]	17 [0.669]	18 [0.709]	22 [0.866]	42 [1.654]	42 [1.654]

● Push side stroke adjusting cylinder

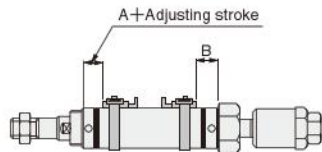

		mm [in.]			
Sensor switch model	Bore size Code	20 [0.787]	25 [0.984]	32 [1.260]	40 [1.575]
		ZG530□ ZG553□ CS□M	A	27 [1.063]	27 [1.063]
CS□F	A	22 [0.866]	22 [0.866]	22 [0.866]	22 [0.866]
	B	22 [0.866]	22 [0.866]	22 [0.866]	22 [0.866]

● Pull side stroke adjusting cylinder

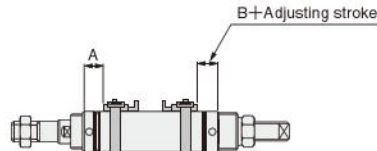

		mm [in.]			
Sensor switch model	Code	Bore size			
		20 [0.787]	25 [0.984]	32 [1.260]	40 [1.575]
ZG530□ ZG553□ CS□M	A	27 [1.063]	27 [1.063]	27 [1.063]	27 [1.063]
	B	37 [1.457]	37 [1.457]	42 [1.654]	42 [1.654]
CS□F	A	22 [0.866]	22 [0.866]	22 [0.866]	22 [0.866]
	B	32 [1.260]	32 [1.260]	37 [1.457]	37 [1.457]

Moving Sensor Switch

- ZG530
- ZG553
- CS M

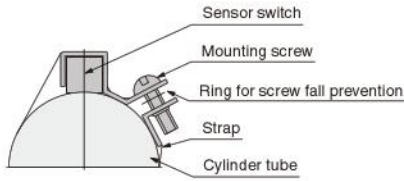

- Loosening the mounting screw allows the sensor switch to be moved freely along with the strap in the axial and circumferential direction. The sensor switch alone cannot be moved.
- To remove the sensor switch from the strap, first detach the strap from the cylinder tube and then remove the sensor switch from the strap.
- Tighten the mounting screw with a tightening torque of 49N·cm [4.3in·lbf].

- CS F

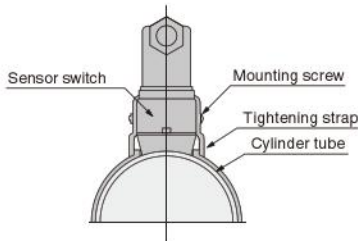

- Loosening the mounting screw allows the sensor switch to be moved freely in the axial and circumferential direction.
- Slightly loosening the mounting screw allows fine adjustment of the lead switch only, up to 5mm [0.2in.] in the axial direction. Tighten the mounting screw with a tightening torque of 68.6N·cm [6.1in·lbf].

Dimensions of Sensor Switch (mm)

- ZG530
- ZG553
- CS M

φ 16

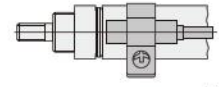
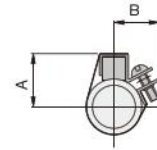

Lead wire length
A: 1000mm [39in.]
B: 3000mm [118in.]

φ 20 ~ φ 63

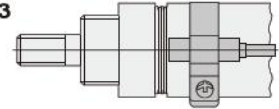
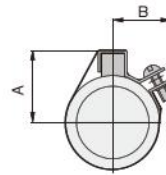

Lead wire length
A: 1000mm [39in.]
B: 3000mm [118in.]

		mm [in.]	
Bore	Code	A	B
16	[0.630]	16	15
20	[0.787]	19	17
25	[0.984]	20.5	17.5
32	[1.260]	25	19
40	[1.575]	29	—*
50	[1.969]	34	—*
63	[2.480]	41	—*

* At φ 40 or larger, dimension B is the radius of the cylinder tube. Therefore, the protrusion in the B direction of the mounting section disappears.

- CS F

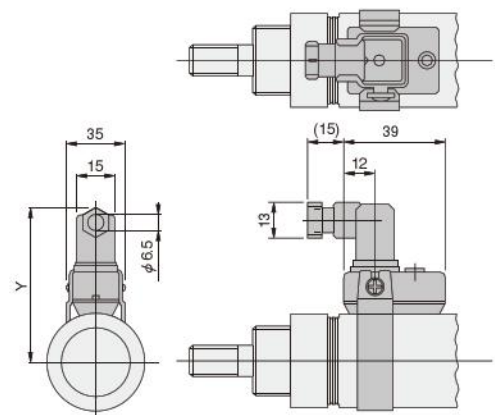

		mm [in.]
Bore	Code	Y
20	[0.787]	59
25	[0.984]	61.5
32	[1.260]	65
40	[1.575]	69
50	[1.969]	76
63	[2.480]	83

ROD END ACCESSORIES

Option

Dimensions

● $\phi 16$

● Y type

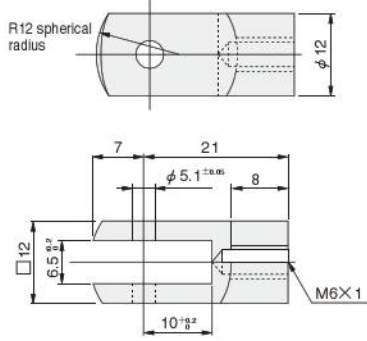

Pin for Y type knuckle

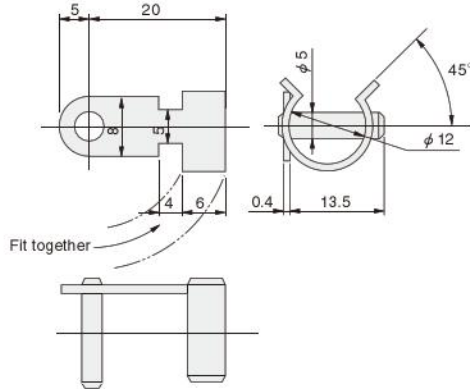

● I type

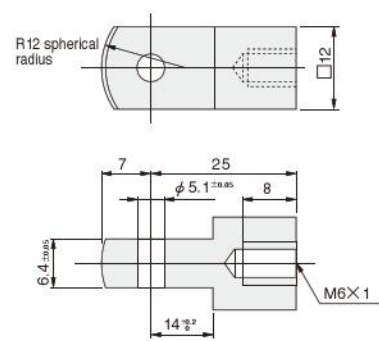

● $\phi 20 \sim \phi 63$

● Y type

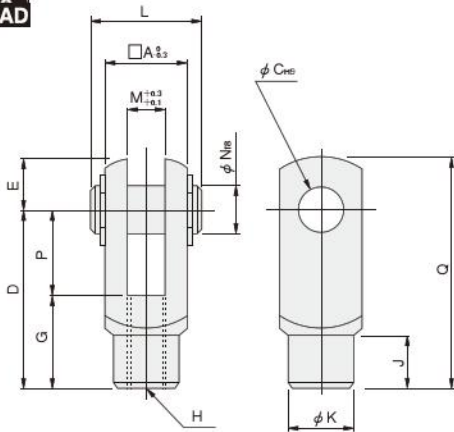

● I type

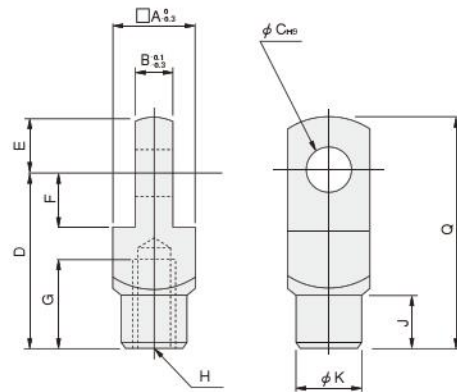

mm [in.]

Bore	Code	A	B	C	D	E	F	G	H	J	K	L	M	N	P	Q
20 [0.787], 25 [0.984]*		16	8	8	30	10	11	15	M8×1	10	14	21	8	8	15	40
25 [0.984], 32 [1.260]		19	10	10	40	12	13	20	M10×1.25	12	16	25	10	10	20	52
40 [1.575], 50 [1.969], 63 [2.480]		24	14	10	45	12	13	25	M14×1.5	15	22	30	14	10	20	57

Note: Items marked with ※ are for the square rod cylinders.

BELLOWS, MOUNTING BRACKETS

CAD SLIM-J

Dimensions (For brake cylinders with bellows, see p.367.)

● $\phi 20 \sim \phi 40$

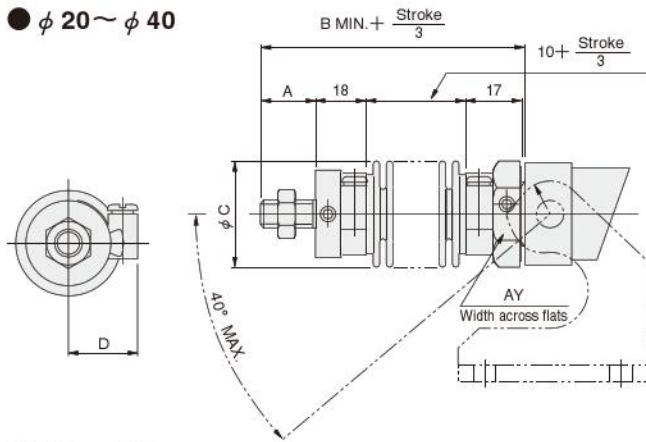

Bore	Code	A	B	C	D	AY
20	[0.787]	15 [0.591]	63 [2.480]	35 [1.378]	23 [0.906]	27 [1.063]
25	[0.984]	18 [0.709]	66 [2.598]	35 [1.378]	23 [0.906]	30 [1.181]
32	[1.260]	23 [0.906]	71 [2.795]	40 [1.575]	26 [1.024]	36 [1.417]
40	[1.575]	23 [0.906]	71 [2.795]	48 [1.890]	29 [1.142]	41 [1.614]

Note: Supporting brackets for the rod trunnion type with bellows should be mounted in the direction opposite to the case of no bellows shown in the diagram.

● $\phi 50, \phi 63$

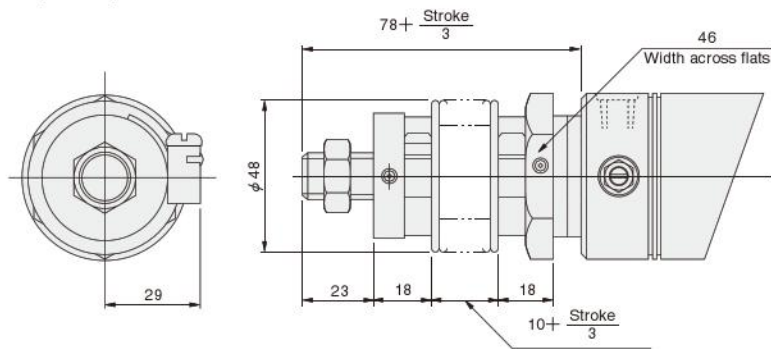

Mass of Slim Cylinder with Bellows

Bore size mm [in.]	Zero stroke mass				Additional mass for each 1mm [0.0394in.] stroke
	Standard head	Short head	Pivot mounting type	Trunnion type	
20 [0.787]	0.25 [0.55] (0.23 [0.51])	0.24 [0.53] (0.22 [0.49])	—	0.44 [0.97]	0.0009 [0.0020]
25 [0.984]	0.29 [0.64] (0.27 [0.60])	0.28 [0.62] (0.26 [0.57])	—	0.47 [1.04]	0.0013 [0.0029]
32 [1.260]	0.43 [0.95] (0.40 [0.88])	0.41 [0.90] (0.38 [0.84])	—	0.60 [1.32]	0.0018 [0.0040]
40 [1.575]	0.62 [1.37] (0.56 [1.23])	0.58 [1.28] (0.52 [1.15])	—	0.78 [1.72]	0.0029 [0.0064]
50 [1.969]	1.03 [2.27]	0.98 [2.16]	0.95 [2.09]	—	0.0033 [0.0073]
63 [2.480]	1.36 [3.00]	1.32 [2.91]	1.29 [2.84]	—	0.0038 [0.0084]

Note: Figures in parentheses () are for the cylinder with variable cushion.

Order Codes for Mounting Bracket

(1) Foot mounting bracket

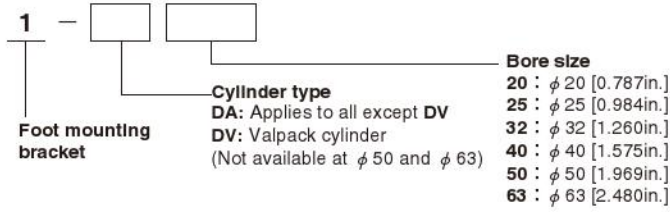

(2) Flange mounting bracket

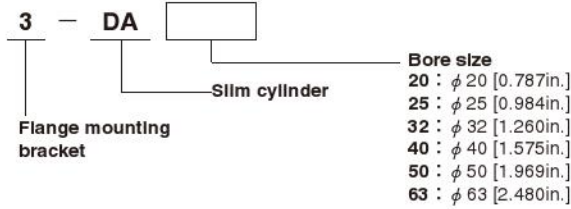

(3) Pivot mounting type supporting bracket

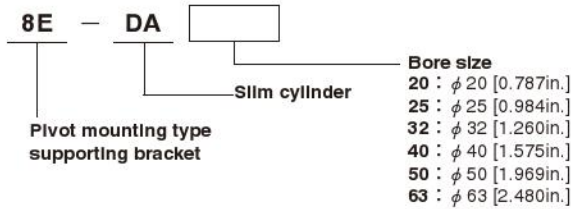

(4) Head trunnion bracket

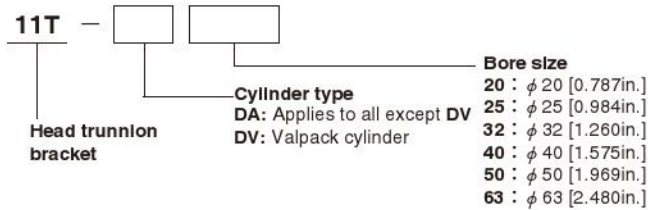

(5) Rod trunnion bracket

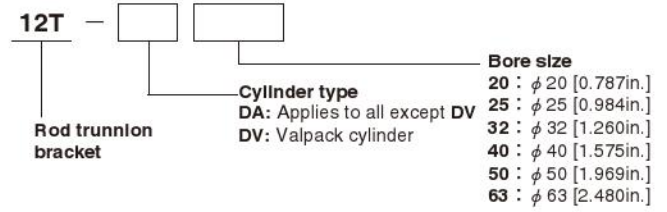

(6) Y type knuckle

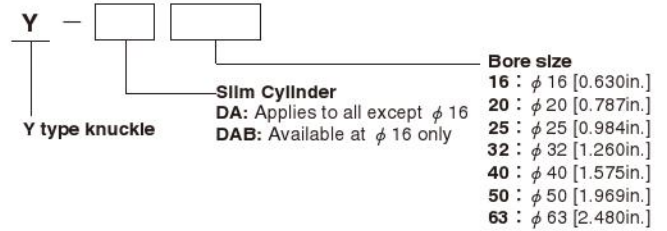

(7) I type knuckle

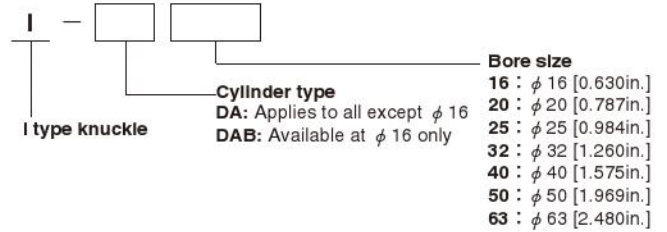

SLIM CYLINDERS