

High-quality stainless steel cylinders ahead of all others

SLIM CYLINDERS

Use durable piston seals.

The two piston seals are the durable PPY type. This prevents inner air leakage, and achieves smooth operation from low-speed to high-speed ranges.

Sensor switches can be installed anytime after cylinder installation.

Magnets as standard equipment across the entire series allow sensor switches to be installed anytime after the cylinder has been installed.

High installation accuracy and simple mounting operations.

A centering location on the rod cover improves mounting precision. Moreover, the mounting nut's improved thread precision means that holding the cylinder body in place by hand is sufficient for mounting nut tightening operations. Mounting in hard-to-reach places is easy.

Criteria for Selection: Slim Cylinder Allowable Kinetic Energy

Slim cylinders (with the exception of heat resistant specifications) include a cushioning mechanism.

This mechanism is intended to reduce as much as possible the impact of pistons with high kinetic energy when they stop at the end of the stroke. There are two types of cushions, as shown below.

● Rubber bumpers (Standard equipment)

Rubber bumpers installed on both sides of the piston soften the impact at the end of the stroke, and absorb the impact noise during stopping, in response to high-frequency and high-speed operations. They are standard equipment across the whole series, with the exception of heat resistant specifications.

Note that a certain amount of rebound will occur at the end of the stroke on the cylinder with the rubber bumpers.

● Variable cushions

Use variable cushions for large load or high-speed operations that rubber bumpers cannot adequately absorb. The impact is absorbed by compressing air, when the piston stops at the end of the stroke.

Since the cushioning stroke is included within the cylinder stroke, be careful to ensure that the cushion is not excessively performed during cylinder applications of 25mm strokes or less. An excessively performed cushion can result in too much time for each stroke, reducing efficiency. When operated at or below the absorbable kinetic energy shown in the table below, the cushion seal life is 1 million operations or more.

The load kinetic energy can be obtained through the formulas shown below.

$$E_x = \frac{m}{2} v^2$$

Ex: Kinetic energy (J)
m: Load mass (kg)
v: Piston speed (m/s)

$$E'_x = \frac{W}{2g} v'^2$$

E'x: Kinetic energy [ft·lbf]
W: Load [lbf.]
v': Piston speed [ft./sec.]
g: Acceleration of gravity 32.2 [ft./sec.²]

Operating speed range

- Rubber bumper 30~800mm/s [1.2~31.5in./sec.]
- Variable cushion 30~1000mm/s [1.2~39.4in./sec.]

Bore size mm [in.]	Allowable kinetic energy J [ft·lbf]	
	With rubber bumpers	With variable cushion
16 [0.630]	0.07 [0.052]	0.18 [0.13]
20 [0.787]	0.27 [0.20]	0.7 [0.52]
25 [0.984]	0.40 [0.30]	1.05 [0.77]
32 [1.260]	0.65 [0.48]	1.8 [1.33]
40 [1.575]	1.2 [0.89]	2.8 [2.07]
50 [1.969]	—	3.5 [2.58]
63 [2.480]	—	4.5 [3.32]

Rubber bumper (Graph 1)



Variable cushion (Graph 2)

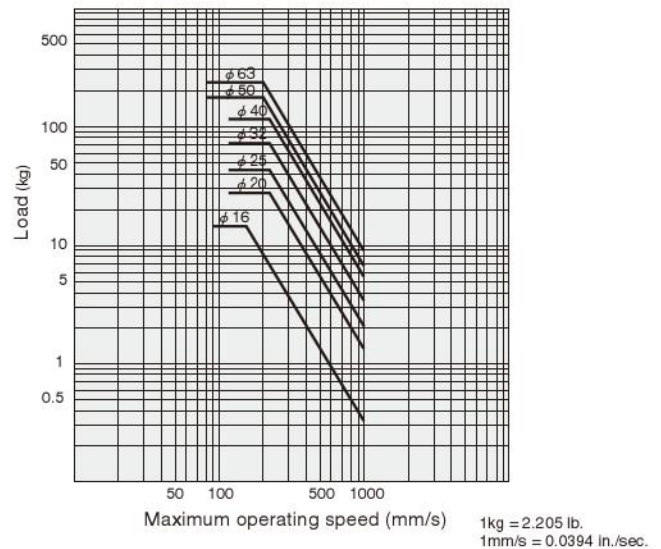

How to read the graphs

From Graph 1, the capacity of the rubber bumpers limits the maximum speed to 500mm/s [19.7in./sec.] or less when a φ32 Slim Cylinder is used to carry a load of 5kg [11.0lb.].
From Graph 2, a φ32 cylinder with variable cushion can be selected to carry a load of 8kg [17.6lb.] at a maximum speed of 600mm/s [23.6in./sec.].

Inner Construction and Major Parts (cannot be disassembled)

● $\phi 20 \sim \phi 40$

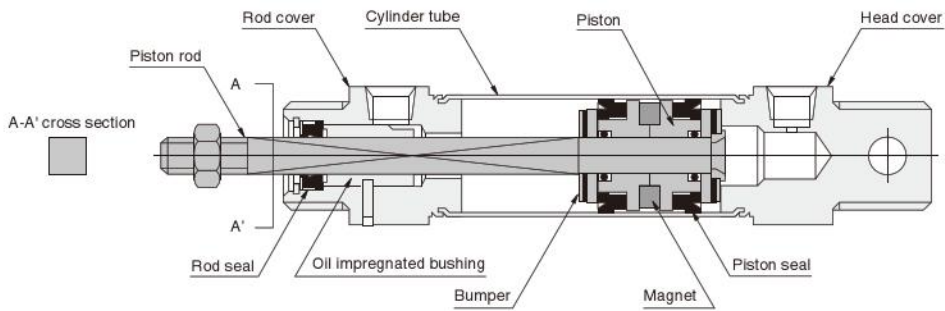

● $\phi 50, \phi 63$

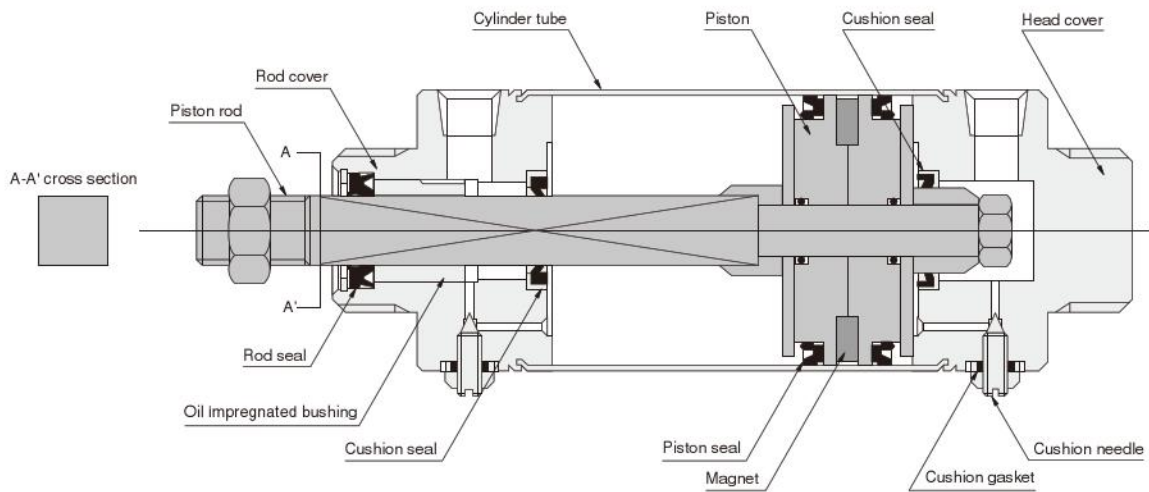

Major Parts and Materials

Parts	Bore size	20~40	50, 63
Cylinder tube		Stainless steel	
Piston		Plastic	
Piston rod		Steel (hard chrome plated)	
Rod cover		Aluminum alloy (anodized)	
Head cover			
Seal		Synthetic rubber (NBR)	
Bumper		Synthetic rubber (NBR)	—
Magnet		Plastic magnet	
Bellows		Nylon tarpaulin (heat resistant temperature 70°C [158°F])	
Y type knuckle, I type knuckle Pivot mounting with supporting bracket		Mild steel (zinc plated)	

Seals Note: Seals cannot be replaced.

Parts	Rod seal	Piston seal	Cushion seal	Cushion gasket
Bore mm	Quantity	1	2	2
20	Quantity	1	2	2
25	Quantity	1	2	2
32	Quantity	1	2	2
40	Quantity	1	2	2
50	Quantity	1	2	2
63	Quantity	1	2	2

Mass

Bore size mm [in.]	Zero stroke mass			Additional mass for each 1mm [0.0394in.] stroke	Mass of mounting bracket				
	Standard head type	Short head type	Pivot mounting type		Foot bracket	Flange bracket	Pivot bracket	Y type knuckle	I type knuckle
20 [0.787]	0.16 [0.35]	0.15 [0.33]	—	0.0008 [0.0018]	0.14 [0.31]	0.08 [0.18]	0.06 [0.13]	0.041 [0.090]	0.036 [0.079]
25 [0.984]	0.20 [0.44]	0.19 [0.42]	—	0.0009 [0.0020]	0.16 [0.35]	0.08 [0.18]	0.06 [0.13]	0.075 [0.165]	0.070 [0.154]
32 [1.260]	0.34 [0.75]	0.32 [0.71]	—	0.0014 [0.0031]	0.19 [0.42]	0.10 [0.22]	0.14 [0.31]	0.075 [0.165]	0.070 [0.154]
40 [1.575]	0.50 [1.10]	0.46 [1.01]	—	0.0021 [0.0046]	0.29 [0.64]	0.13 [0.29]	0.14 [0.31]	0.120 [0.265]	0.132 [0.291]
50 [1.969]	0.90 [1.98]	0.85 [1.87]	0.82 [1.81]	0.0027 [0.0060]	0.55 [1.21]	0.28 [0.62]	0.24 [0.53]	0.120 [0.265]	0.132 [0.291]
63 [2.480]	1.24 [2.73]	1.20 [2.65]	1.17 [2.58]	0.0032 [0.0071]	0.73 [1.61]	0.37 [0.82]	0.24 [0.53]	0.120 [0.265]	0.132 [0.291]

Calculation example: For short head type of 50mm bore size and 100mm stroke with flange mounting bracket
 $0.85 + (0.0026 \times 100) + 0.28 = 1.39\text{kg} [3.06\text{lb.}]$

Dimensions of Square Rod Basic Type (mm)

● $\phi 20 \sim \phi 40$ DAL Bore size \times Stroke

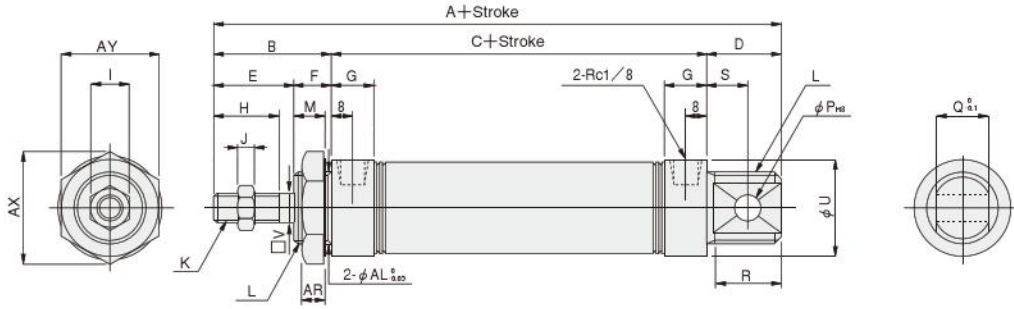

● Short head DAL Bore size \times Stroke -A

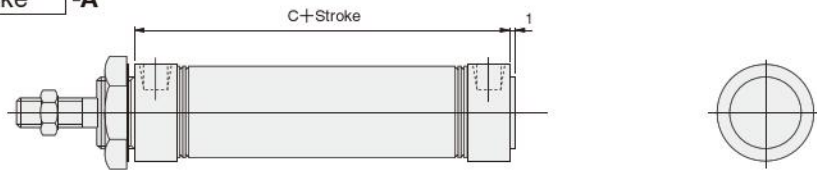

Code	A	B	C	D	E	F	G	H	I	J	K	L	M	P	Q	R	S	U	V	AR	AX	AY	AL
20 [0.787]	132	35	76	21	23	12	16	15	12	5	M 8×1	M20×1.5	10	8	12	19	12	27	7.4	7.5	31.2	27	20
25 [0.984]	137	40	76	21	26	14	16	18	12	5	M 8×1	M22×1.5	12	8	12	19	12	29	7.4	9.5	34.6	30	22
32 [1.260]	148	45	76	27	31	14	16	23	14	6	M10×1.25	M27×2	12	10	20	25	15	35	10	9.5	41.6	36	27
40 [1.575]	148	45	76	27	31	14	(15)	23	19	8	M14×1.5	M33×2	12	10	20	25	15	41.6	13	9.5	47.3	41	33

● $\phi 50, \phi 63$ DAL Bore size \times Stroke

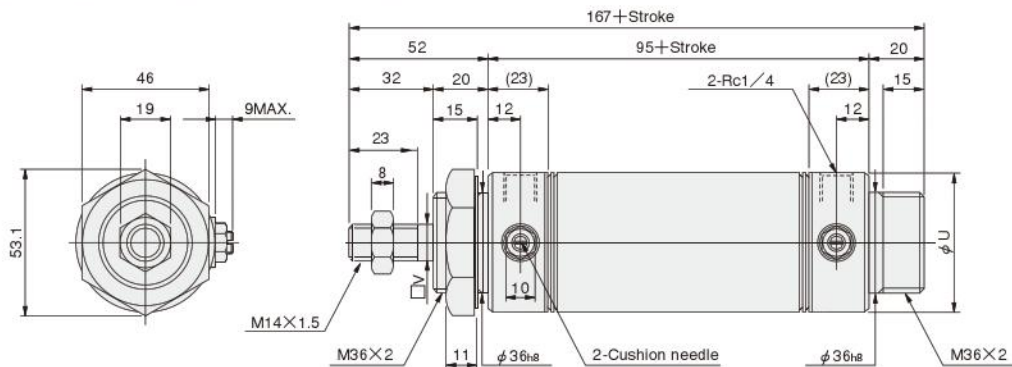

● Short head DAL Bore size \times Stroke -A

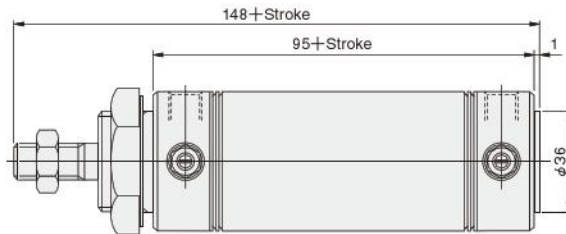

Code	U	V
50 [1.969]	52	13
63 [2.480]	65.4	13

Dimensions of Square Rod Foot Mounting Type (mm)

● $\phi 20 \sim \phi 40$ DAL × -1

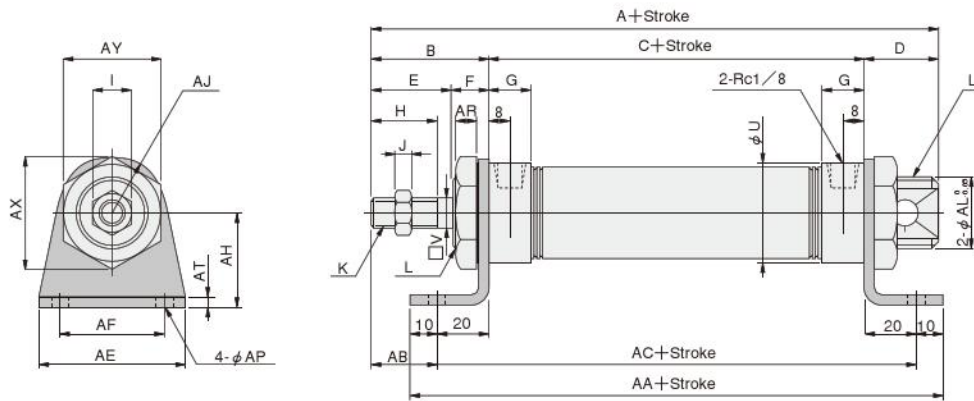

Bore mm [in.]	Code	A	B	C	D	E	F	G	H	I	J	K	L	U	V
20	[0.787]	132	35	76	21	23	12	16	15	12	5	M 8×1	M20×1.5	27	7.4
25	[0.984]	137	40	76	21	26	14	16	18	12	5	M 8×1	M22×1.5	29	7.4
32	[1.260]	148	45	76	27	31	14	16	23	14	6	M10×1.25	M27×2	35	10
40	[1.575]	148	45	76	27	31	14	15	23	19	8	M14×1.5	M33×2	41.6	13

Bore mm [in.]	Code	AA	AB	AC	AE	AF	AH	AJ	AP	AR	AT	AX	AY
20	[0.787]	136	15	116	55	40	25	15.5	6.8	7.5	3.2	31.2	27
25	[0.984]	136	20	116	55	40	30	17	6.8	9.5	3.2	34.6	30
32	[1.260]	136	25	116	55	40	35	20	6.8	9.5	3.2	41.6	36
40	[1.575]	136	25	116	75	55	40	23.5	9	9.5	4	47.3	41

● $\phi 50, \phi 63$ DAL × -1

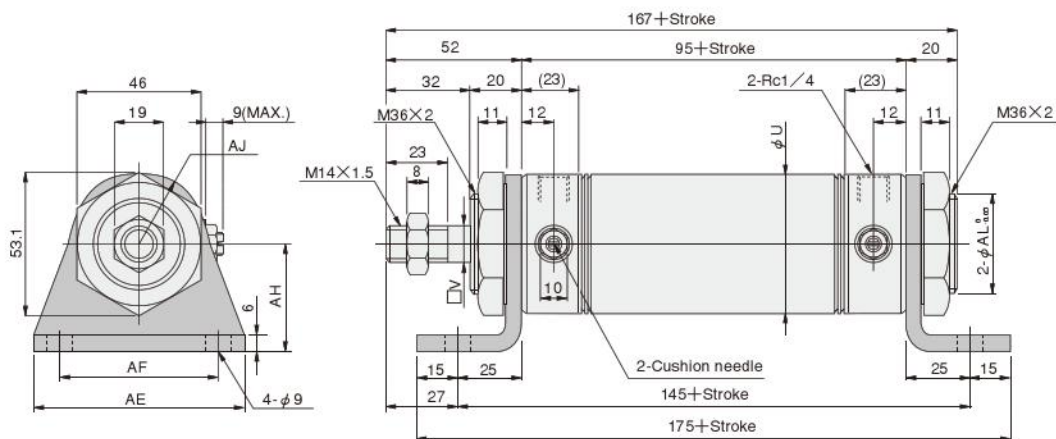

Bore mm [in.]	Code	U	V	AE	AF	AH	AJ
50	[1.969]	52	13	80	60	40	26
63	[2.480]	65.4	13	95	74	45	32

Dimensions of Square Rod Pivot Mounting Type (mm)

● $\phi 20 \sim \phi 40$ DAL Bore size \times Stroke -8E

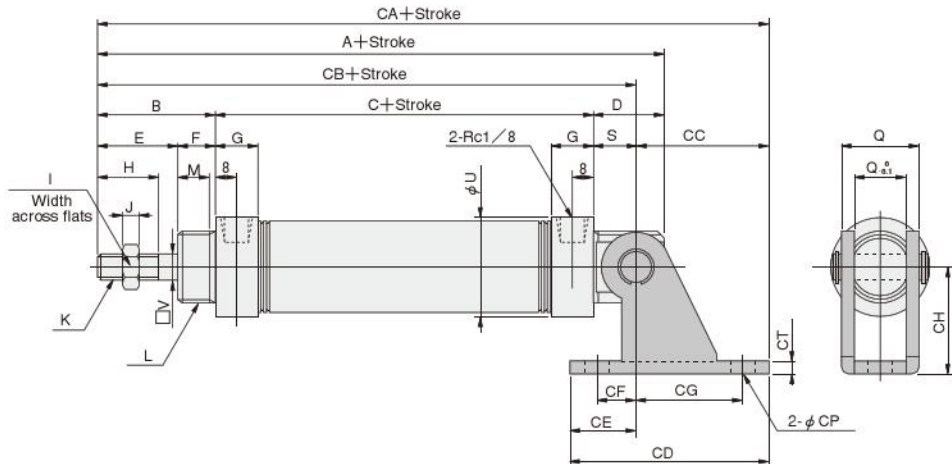

Bore mm [in.]	Code	A	B	C	D	E	F	G	H	I	J	K	L	M	Q	S	U	V
20 [0.787]		132	35	76	21	23	12	16	15	12	5	M 8×1	M20×1.5	10	12	12	27	7.4
25 [0.984]		137	40	76	21	26	14	16	18	14	6	M 8×1	M22×1.5	12	12	12	29	7.4
32 [1.260]		148	45	76	27	31	14	16	23	14	6	M10×1.25	M27×2	12	20	15	35	10
40 [1.575]		148	45	76	27	31	14	(14.5)	23	19	8	M14×1.5	M33×2	12	20	15	41.6	13

Bore mm [in.]	Code	CA	CB	CC	CD	CE	CF	CG	CH	CP	CQ	CT
20 [0.787]		160	123	37	59	22	15	30	30	6.8	18.4	3.2
25 [0.984]		165	128	37	59	22	15	30	30	6.8	18.4	3.2
32 [1.260]		186	136	50	75	25	15	40	40	9	28	4
40 [1.575]		186	136	50	75	25	15	40	40	9	28	4

● $\phi 50, \phi 63$

● Pivot mounting type with bushing DAL Bore size \times Stroke -8B

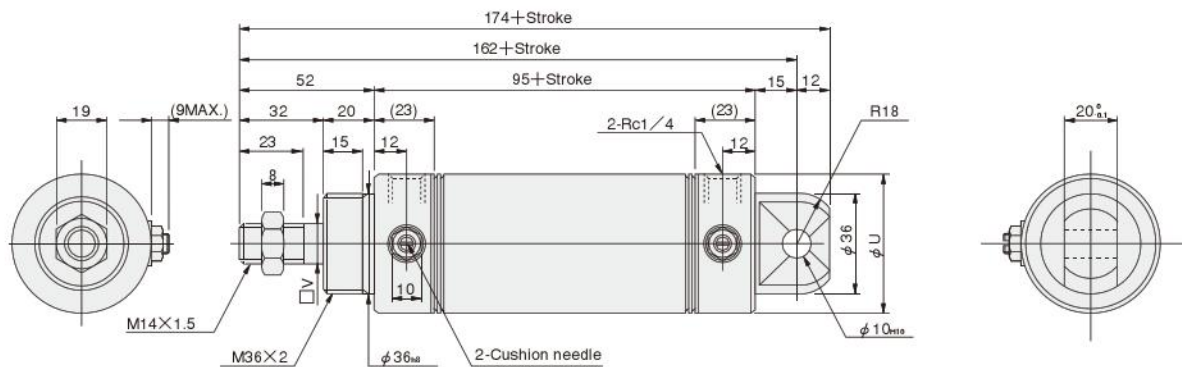

● Pivot mounting type with bushing DAL Bore size \times Stroke -8B-8E
(With supporting bracket)

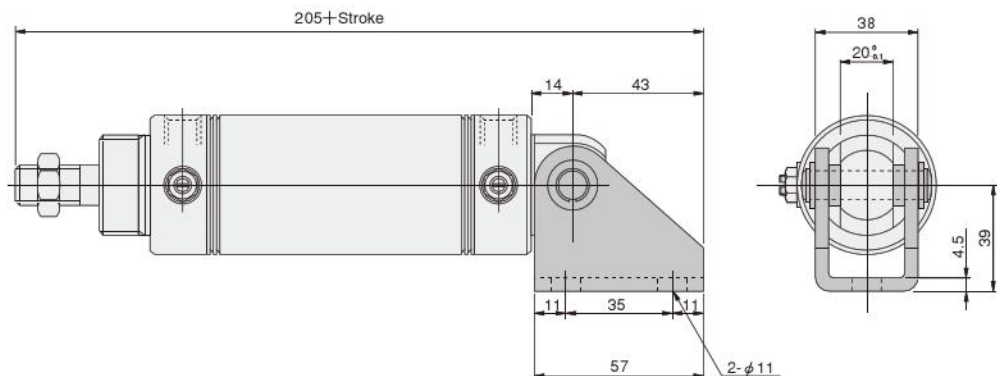

Bore mm [in.]	Code	U	V
50 [1.969]		52	13
63 [2.480]		65.4	13

SENSOR SWITCHES

Solid State Type, Reed Switch Type

- Since a magnet is already standard on the Slim cylinders series^{Note}, mounting a sensor switch will enable use in sensor switch applications.

Note: Except the heat resistant specification cylinder.

Symbol



Order Codes

- Order codes for sensor switches mounted on the Slim cylinders

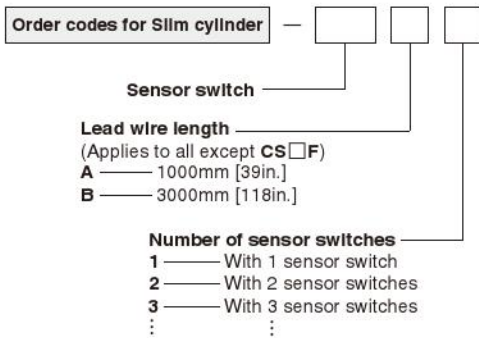

Sensor switch	For	with indicator lamp	
ZG530	φ16~φ63	with indicator lamp	DC10~30V
ZG553	φ16~φ63	with indicator lamp	DC4.5~28V
CS3M	φ16~φ63	with indicator lamp	DC10~30V
CS4M	φ16~φ63	with indicator lamp	AC85~230V
CS5M	φ16~φ63	without indicator lamp	DC10~30V
CS2F	φ20~φ63	with indicator lamp	AC85~115V
CS3F	φ20~φ63	with indicator lamp	DC3~30V
CS4F	φ20~φ63	with indicator lamp	AC85~115V
CS5F	φ20~φ63	without indicator lamp	AC85~230V
			DC10~30V
			DC3~30V

- Order codes for sensor switch only

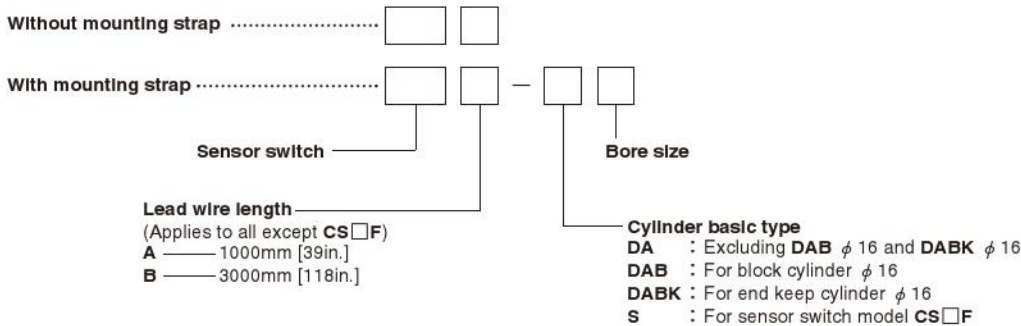

- Order codes for mounting strap only

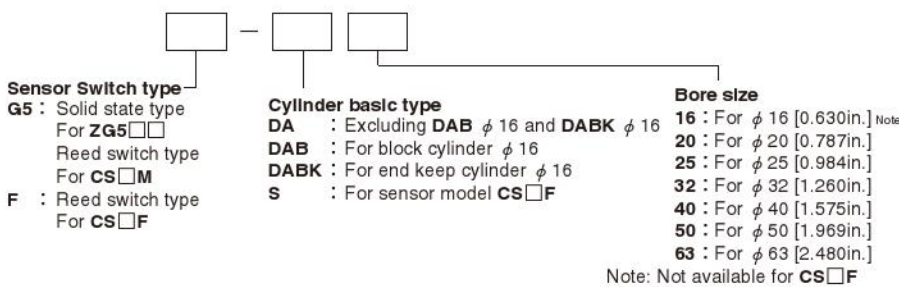

Minimum Cylinder Strokes When Using Sensor Switches

Sensor switch model	Bore size	2 pcs. mounting		1 pc. mounting
		mm		
		Along a straight line	In staggered positions	
ZG530	16	20	10	10
ZG553	20~63	20	10	10
CS□M	16~63	20	15	15
CS□F	20~63	40	21	15

● Two pieces mounting ● One piece mounting

● When mounted in-line

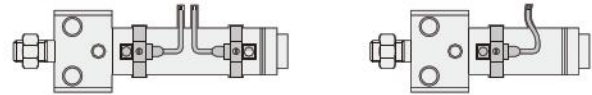

● When mounted in staggered positions

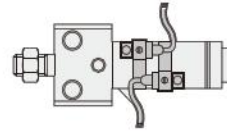

Sensor Switch Operating Range, Response Differential, and Maximum Sensing Location

● Operating range : ℓ

The distance the piston travels in one direction, while the switch is in the ON position.

● Response differential : C

The distance between the point where the piston turns the switch ON and the point where the switch is turned OFF as the piston travels in the opposite direction.

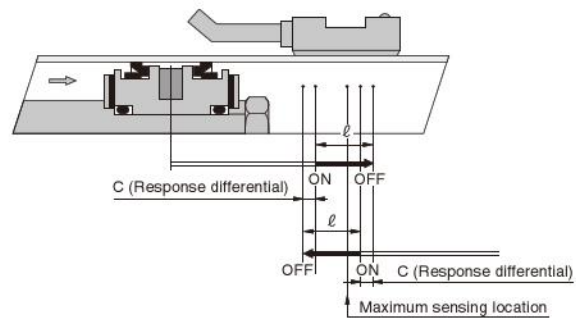

Item	Bore size	mm [in.]						
		16 [0.630]	20 [0.787]	25 [0.984]	32 [1.260]	40 [1.575]	50 [1.969]	63 [2.480]
Operating range : ℓ	ZG530□	2.5~4.1 [0.098~0.161]	2.5~4.2 [0.098~0.165]	2.6~4.3 [0.102~0.169]	3.0~4.8 [0.118~0.189]	3.1~5.0 [0.122~0.197]	3.3~5.4 [0.130~0.213]	3.5~5.7 [0.138~0.224]
	ZG553□	—	—	—	—	—	—	—
	CS□M	6.7~7 [0.264~0.276]	7~8.5 [0.276~0.335]	7~8.5 [0.276~0.335]	8~9 [0.315~0.354]	9~10.5 [0.354~0.413]	7~8 [0.276~0.315]	8~9.5 [0.315~0.374]
	CS□F	—	7~8.5 [0.276~0.335]	8.5~10 [0.335~0.394]	9~10.5 [0.354~0.413]	10.5~12 [0.413~0.472]	9~10 [0.354~0.394]	9~10.5 [0.354~0.413]
Response differential : C	ZG530	0.7 [0.028] or less	0.7 [0.028] or less	0.8 [0.031] or less	0.7 [0.028] or less	0.8 [0.031] or less	0.8 [0.031] or less	0.8 [0.031] or less
	ZG553	0.7 [0.028] or less	0.7 [0.028] or less	0.8 [0.031] or less	0.7 [0.028] or less	0.8 [0.031] or less	0.8 [0.031] or less	0.8 [0.031] or less
	CS□M	1 [0.039] or less	1 [0.039] or less	1 [0.039] or less	1 [0.039] or less	1 [0.039] or less	1.2 [0.047] or less	1.2 [0.047] or less
	CS□F	—	1.5 [0.059] or less	1.5 [0.059] or less	1.5 [0.059] or less	1.5 [0.059] or less	2 [0.079] or less	1.5 [0.059] or less
Maximum sensing location	ZG530, ZG553 ^{Note 1}	11 [0.433]	11 [0.433]	11 [0.433]	11 [0.433]	11 [0.433]	11 [0.433]	11 [0.433]
	CS□M ^{Note 1}	11 [0.433]	11 [0.433]	11 [0.433]	11 [0.433]	11 [0.433]	11 [0.433]	11 [0.433]
	CS□F ^{Note 2}	—	16 [0.630]	16 [0.630]	16 [0.630]	16 [0.630]	16 [0.630]	16 [0.630]

Remark: Figures in the table above are reference values.

Notes: 1. Figures are lengths measured from the switch's opposite end side to the lead wire.

2. Figures are lengths measured from the connector side's end surface to the lead wire.

Mounting Location of End of Stroke Detection Sensor Switch

When the sensor switch is mounted in the location shown in the diagram (figures in the table are reference values), the magnet comes to the sensor switch's maximum sensing location at the end of the stroke.

● Air cylinder, Low hydraulic cylinder, Valpack cylinder

● Air cylinder, Low hydraulic cylinder ● Valpack cylinder

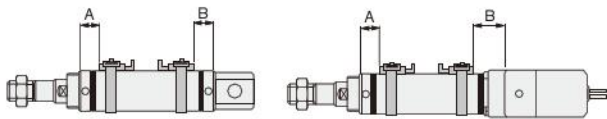

		mm [in.]									
Sensor switch model	Bore size Code	Air cylinder, Low hydraulic cylinder					Valpack cylinder				
		20	25	32	40	50	63	20	25	32	40
ZG530□ ZG553□	A	27 [1.063]	27 [1.063]	27 [1.063]	27 [1.063]	36 [1.417]	36 [1.417]	27 [1.063]	27 [1.063]	27 [1.063]	27 [1.063]
	B	27 [1.063]	27 [1.063]	27 [1.063]	27 [1.063]	36 [1.417]	36 [1.417]	39 [1.535]	39 [1.535]	39 [1.535]	44 [1.732]
CS□M	A	27 [1.063]	27 [1.063]	27 [1.063]	27 [1.063]	36 [1.417]	36 [1.417]	27 [1.063]	27 [1.063]	27 [1.063]	27 [1.063]
	B	27 [1.063]	27 [1.063]	27 [1.063]	27 [1.063]	36 [1.417]	36 [1.417]	39 [1.535]	39 [1.535]	39 [1.535]	44 [1.732]
CS□F	A	22 [0.866]	22 [0.866]	22 [0.866]	22 [0.866]	32 [1.260]	32 [1.260]	22 [0.866]	22 [0.866]	22 [0.866]	22 [0.866]
	B	22 [0.866]	22 [0.866]	22 [0.866]	22 [0.866]	32 [1.260]	32 [1.260]	34 [1.339]	34 [1.339]	34 [1.339]	39 [1.535]

● Single acting cylinder

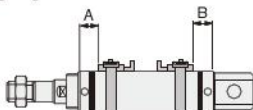

		mm [in.]				
Sensor switch model	Code	Stroke	Bore size			
			20 [0.787]	25 [0.984]	32 [1.260]	40 [1.575]
ZG530□ ZG553□ CS□M	A	0~25	35 [1.378]	36 [1.417]	35 [1.378]	37 [1.457]
		26~50	52 [2.047]	49 [1.929]	49 [1.929]	53 [2.087]
		51~75	72 [2.835]	71 [2.795]	72 [2.835]	68 [2.677]
		76~100	—	84 [3.307]	86 [3.386]	95 [3.740]
		101~125	—	—	—	110 [4.331]
		126~150	—	—	—	125 [4.921]
CS□F	A	0~25	30 [1.181]	31 [1.220]	30 [1.181]	32 [1.260]
		26~50	47 [1.850]	44 [1.732]	44 [1.732]	48 [1.890]
		51~75	67 [2.638]	66 [2.598]	67 [2.638]	63 [2.480]
		76~100	—	79 [3.110]	81 [3.189]	90 [3.543]
		101~125	—	—	—	105 [4.134]
		126~150	—	—	—	120 [4.724]
CS□F	B	—	22 [0.866]	22 [0.866]	22 [0.866]	22 [0.866]

● Block cylinder

● Side mount

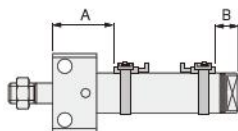

● Front mount

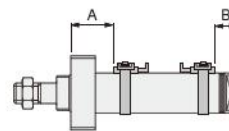

Mounting type		mm [in.]													
Bore size		Side mount					Front mount								
		16	20	25	32	40	50	63	16	20	25	32	40	50	63
ZG530□	A Rod side	32 [1.260]	39 [1.535]	41 [1.614]	47 [1.850]	57 [2.244]	67 [2.638]	67 [2.638]	23 [0.906]	27 [1.063]	27 [1.063]	27 [1.063]	29 [1.142]	37 [1.457]	37 [1.457]
ZG553□	B Rod side	16 [0.630]	20 [0.787]	20 [0.787]	21 [0.827]	25 [0.984]	45 [1.772]	45 [1.772]	16 [0.630]	20 [0.787]	20 [0.787]	21 [0.827]	25 [0.984]	45 [1.772]	45 [1.772]
CS□M	A Rod side	32 [1.260]	39 [1.535]	41 [1.614]	47 [1.850]	57 [2.244]	66 [2.598]	66 [2.598]	23 [0.906]	27 [1.063]	27 [1.063]	27 [1.063]	29 [1.142]	36 [1.417]	36 [1.417]
	B Rod side	16 [0.630]	20 [0.787]	20 [0.787]	21 [0.827]	25 [0.984]	44 [1.732]	44 [1.732]	16 [0.630]	20 [0.787]	20 [0.787]	21 [0.827]	25 [0.984]	44 [1.732]	44 [1.732]
CS□F	A Rod side	—	36 [1.417]	38 [1.496]	44 [1.732]	52 [2.047]	64 [2.520]	64 [2.520]	—	24 [0.945]	24 [0.945]	24 [0.945]	24 [0.945]	34 [1.339]	34 [1.339]
	B Rod side	—	17 [0.669]	17 [0.669]	18 [0.709]	20 [0.787]	42 [1.654]	42 [1.654]	—	17 [0.669]	17 [0.669]	18 [0.709]	22 [0.866]	42 [1.654]	42 [1.654]

SLIM CYLINDERS

Moving Sensor Switch

- ZG530
- ZG553
- CS M

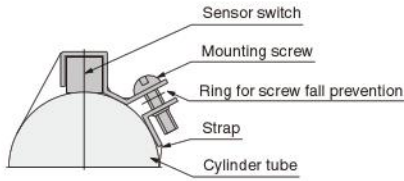

- Loosening the mounting screw allows the sensor switch to be moved freely along with the strap in the axial and circumferential direction. The sensor switch alone cannot be moved.
- To remove the sensor switch from the strap, first detach the strap from the cylinder tube and then remove the sensor switch from the strap.
- Tighten the mounting screw with a tightening torque of 49N·cm [4.3in·lbf].

- CS F

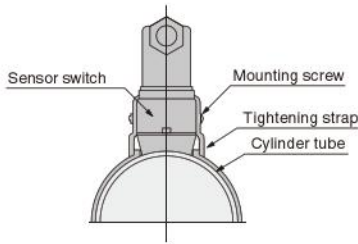

- Loosening the mounting screw allows the sensor switch to be moved freely in the axial and circumferential direction.
- Slightly loosening the mounting screw allows fine adjustment of the lead switch only, up to 5mm [0.2in.] in the axial direction. Tighten the mounting screw with a tightening torque of 68.6N·cm [6.1in·lbf].

Dimensions of Sensor Switch (mm)

- ZG530
- ZG553
- CS M

φ 16

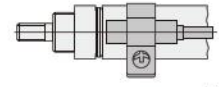
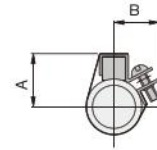

Lead wire length
A: 1000mm [39in.]
B: 3000mm [118in.]

φ 20 ~ φ 63

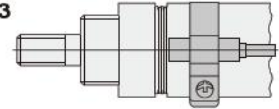
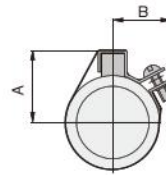

Lead wire length
A: 1000mm [39in.]
B: 3000mm [118in.]

		mm [in.]	
Bore	Code	A	B
16	[0.630]	16	15
20	[0.787]	19	17
25	[0.984]	20.5	17.5
32	[1.260]	25	19
40	[1.575]	29	—*
50	[1.969]	34	—*
63	[2.480]	41	—*

* At φ 40 or larger, dimension B is the radius of the cylinder tube. Therefore, the protrusion in the B direction of the mounting section disappears.

- CS F

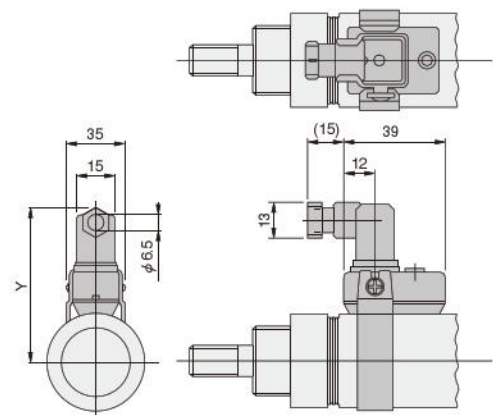

		mm [in.]
Bore	Code	Y
20	[0.787]	59
25	[0.984]	61.5
32	[1.260]	65
40	[1.575]	69
50	[1.969]	76
63	[2.480]	83

ROD END ACCESSORIES

Option

Dimensions

● $\phi 16$

● Y type

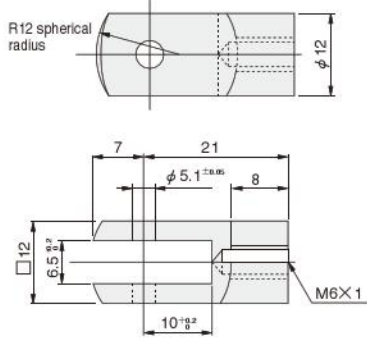

Pin for Y type knuckle

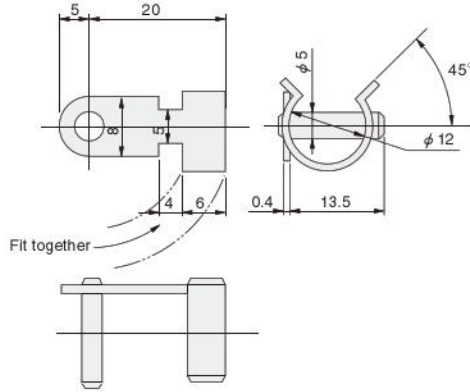

● I type

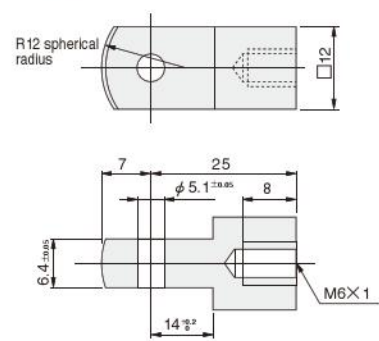

● $\phi 20 \sim \phi 63$

● Y type

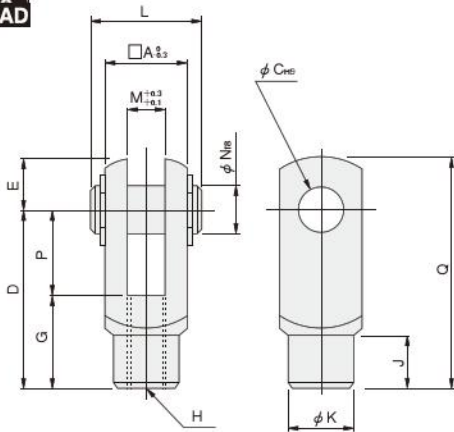

● I type

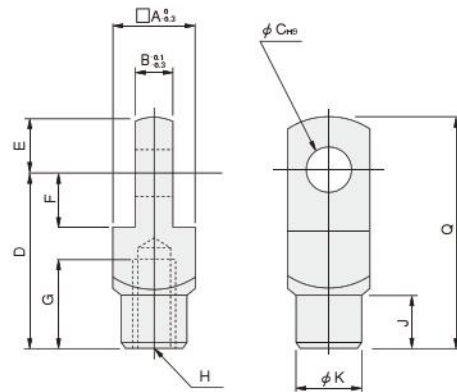

mm [in.]

Bore	Code	A	B	C	D	E	F	G	H	J	K	L	M	N	P	Q
20 [0.787], 25 [0.984]*		16	8	8	30	10	11	15	M8×1	10	14	21	8	8	15	40
25 [0.984], 32 [1.260]		19	10	10	40	12	13	20	M10×1.25	12	16	25	10	10	20	52
40 [1.575], 50 [1.969], 63 [2.480]		24	14	10	45	12	13	25	M14×1.5	15	22	30	14	10	20	57

Note: Items marked with ※ are for the square rod cylinders.

BELLOWS, MOUNTING BRACKETS



Dimensions (For brake cylinders with bellows, see p.367.)

● $\phi 20 \sim \phi 40$

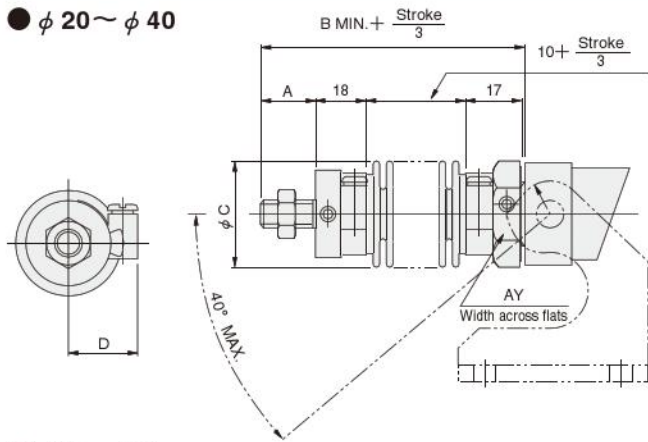

Bore	Code	A	B	C	D	AY
20	[0.787]	15 [0.591]	63 [2.480]	35 [1.378]	23 [0.906]	27 [1.063]
25	[0.984]	18 [0.709]	66 [2.598]	35 [1.378]	23 [0.906]	30 [1.181]
32	[1.260]	23 [0.906]	71 [2.795]	40 [1.575]	26 [1.024]	36 [1.417]
40	[1.575]	23 [0.906]	71 [2.795]	48 [1.890]	29 [1.142]	41 [1.614]

Note: Supporting brackets for the rod trunnion type with bellows should be mounted in the direction opposite to the case of no bellows shown in the diagram.

● $\phi 50, \phi 63$

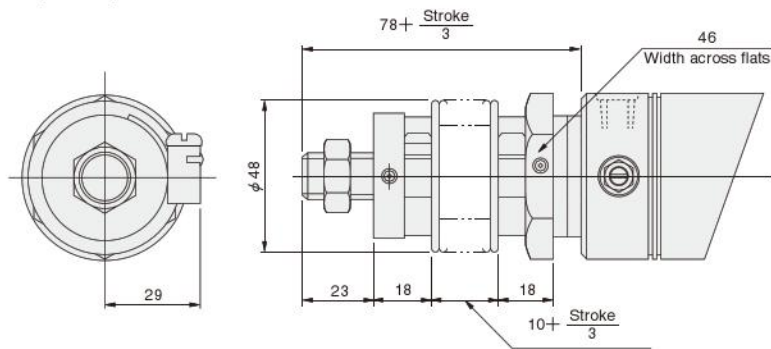

Mass of Slim Cylinder with Bellows

Bore size mm [in.]	Zero stroke mass				Additional mass for each 1mm [0.0394in.] stroke
	Standard head	Short head	Pivot mounting type	Trunnion type	
20 [0.787]	0.25 [0.55] (0.23 [0.51])	0.24 [0.53] (0.22 [0.49])	—	0.44 [0.97]	0.0009 [0.0020]
25 [0.984]	0.29 [0.64] (0.27 [0.60])	0.28 [0.62] (0.26 [0.57])	—	0.47 [1.04]	0.0013 [0.0029]
32 [1.260]	0.43 [0.95] (0.40 [0.88])	0.41 [0.90] (0.38 [0.84])	—	0.60 [1.32]	0.0018 [0.0040]
40 [1.575]	0.62 [1.37] (0.56 [1.23])	0.58 [1.28] (0.52 [1.15])	—	0.78 [1.72]	0.0029 [0.0064]
50 [1.969]	1.03 [2.27]	0.98 [2.16]	0.95 [2.09]	—	0.0033 [0.0073]
63 [2.480]	1.36 [3.00]	1.32 [2.91]	1.29 [2.84]	—	0.0038 [0.0084]

Note: Figures in parentheses () are for the cylinder with variable cushion.

Order Codes for Mounting Bracket

(1) Foot mounting bracket

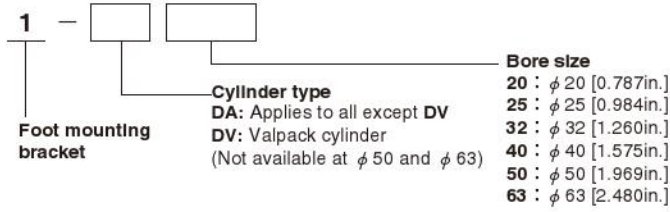

(2) Flange mounting bracket

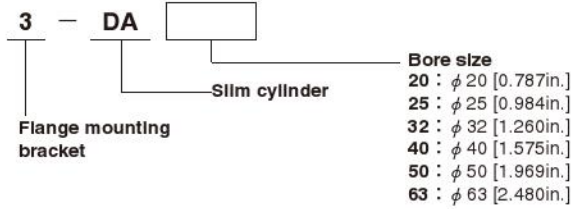

(3) Pivot mounting type supporting bracket

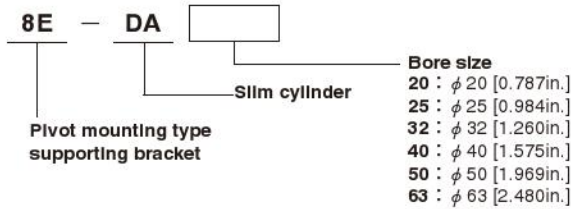

(4) Head trunnion bracket

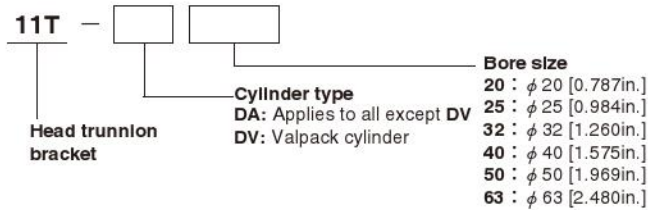

(5) Rod trunnion bracket

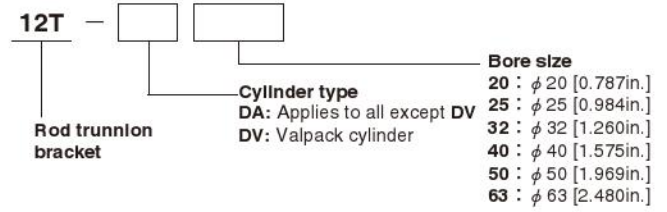

(6) Y type knuckle

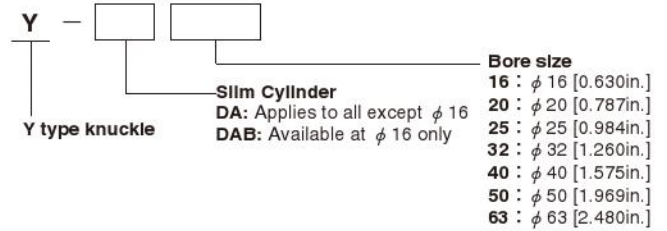

(7) I type knuckle

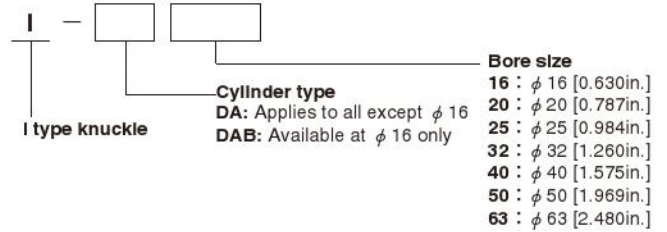

SLIM CYLINDERS