

High-quality stainless steel cylinders ahead of all others

# SLIM CYLINDERS

## Use durable piston seals.

The two piston seals are the durable PPY type. This prevents inner air leakage, and achieves smooth operation from low-speed to high-speed ranges.

## Sensor switches can be installed anytime after cylinder installation.

Magnets as standard equipment across the entire series allow sensor switches to be installed anytime after the cylinder has been installed.

## High installation accuracy and simple mounting operations.

A centering location on the rod cover improves mounting precision. Moreover, the mounting nut's improved thread precision means that holding the cylinder body in place by hand is sufficient for mounting nut tightening operations. Mounting in hard-to-reach places is easy.

## Criteria for Selection: Slim Cylinder Allowable Kinetic Energy

Slim cylinders (with the exception of heat resistant specifications) include a cushioning mechanism.

This mechanism is intended to reduce as much as possible the impact of pistons with high kinetic energy when they stop at the end of the stroke. There are two types of cushions, as shown below.

### ● Rubber bumpers (Standard equipment)

Rubber bumpers installed on both sides of the piston soften the impact at the end of the stroke, and absorb the impact noise during stopping, in response to high-frequency and high-speed operations. They are standard equipment across the whole series, with the exception of heat resistant specifications.

Note that a certain amount of rebound will occur at the end of the stroke on the cylinder with the rubber bumpers.

### ● Variable cushions

Use variable cushions for large load or high-speed operations that rubber bumpers cannot adequately absorb. The impact is absorbed by compressing air, when the piston stops at the end of the stroke.

Since the cushioning stroke is included within the cylinder stroke, be careful to ensure that the cushion is not excessively performed during cylinder applications of 25mm strokes or less. An excessively performed cushion can result in too much time for each stroke, reducing efficiency. When operated at or below the absorbable kinetic energy shown in the table below, the cushion seal life is 1 million operations or more.

The load kinetic energy can be obtained through the formulas shown below.

$$E_x = \frac{m}{2} v^2$$

Ex: Kinetic energy (J)  
m: Load mass (kg)  
v: Piston speed (m/s)

$$E'_x = \frac{W}{2g} v'^2$$

E'x: Kinetic energy [ft·lbf]  
W: Load [lbf.]  
v': Piston speed [ft./sec.]  
g: Acceleration of gravity 32.2 [ft./sec.<sup>2</sup>]

### Operating speed range

- Rubber bumper ..... 30~800mm/s [1.2~31.5in./sec.]
- Variable cushion ..... 30~1000mm/s [1.2~39.4in./sec.]

Bore size mm [in.]	Allowable kinetic energy J [ft·lbf]	
	With rubber bumpers	With variable cushion
16 [0.630]	0.07 [0.052]	0.18 [0.13]
20 [0.787]	0.27 [0.20]	0.7 [0.52]
25 [0.984]	0.40 [0.30]	1.05 [0.77]
32 [1.260]	0.65 [0.48]	1.8 [1.33]
40 [1.575]	1.2 [0.89]	2.8 [2.07]
50 [1.969]	—	3.5 [2.58]
63 [2.480]	—	4.5 [3.32]

Rubber bumper (Graph 1)



Variable cushion (Graph 2)

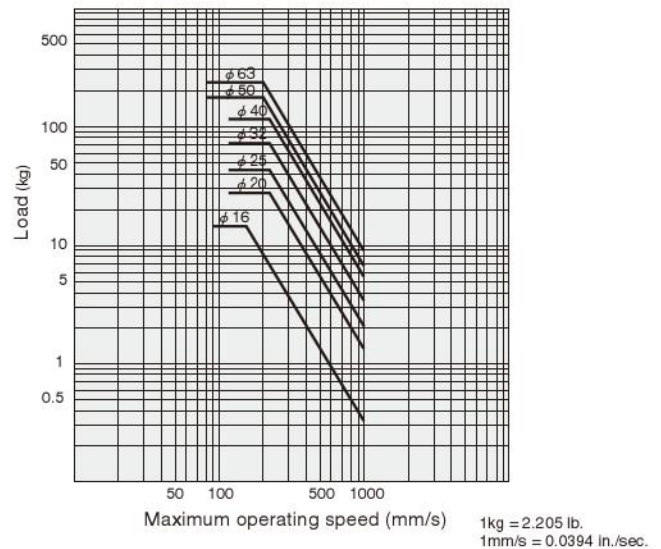

### How to read the graphs

From Graph 1, the capacity of the rubber bumpers limits the maximum speed to 500mm/s [19.7in./sec.] or less when a φ32 Slim Cylinder is used to carry a load of 5kg [11.0lb.].

From Graph 2, a φ32 cylinder with variable cushion can be selected to carry a load of 8kg [17.6lb.] at a maximum speed of 600mm/s [23.6in./sec.].



# Inner Construction and Major Parts (cannot be disassembled)

SLIM CYLINDERS

●  $\phi 20, \phi 25$

● Rod side end keep

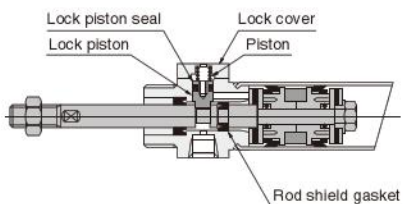

● Head side end keep

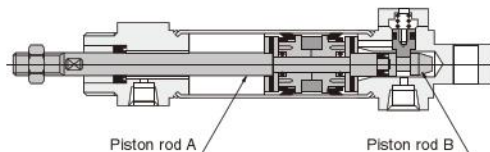

●  $\phi 32, \phi 40$

● Rod side end keep

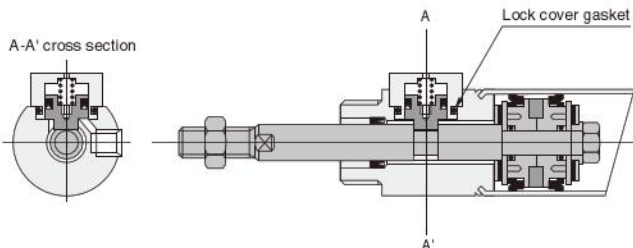

● Head side end keep

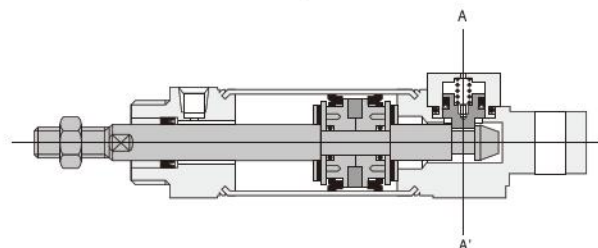

●  $\phi 50, \phi 63$

● Rod side end keep

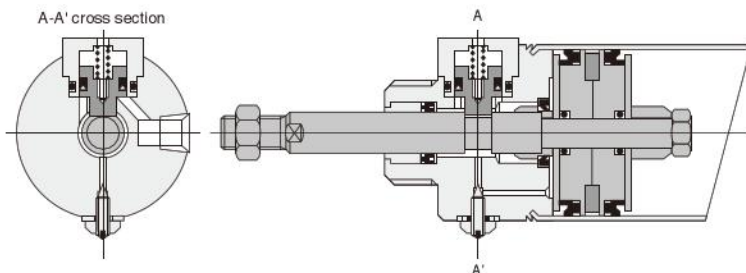

● Head side end keep

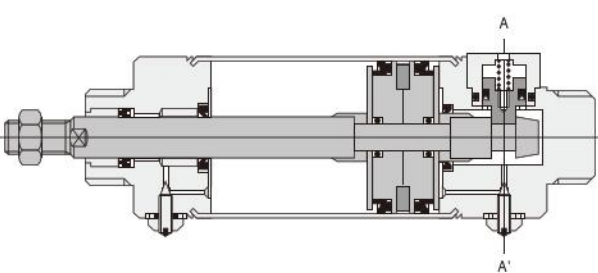

## Major Parts and Materials

Parts	20, 25	32, 40, 50, 63
Piston rod A	Steel (hard chrome plated)	
Piston rod B	Steel (zinc plated)	
Spring	Stainless steel	Piano wire
Lock piston	Stainless steel	
Rod cover	Aluminum alloy (anodized)	
Y type knuckle, I type knuckle Pivot mounting with supporting bracket	Mild steel (zinc plated)	

Other than the items listed above, they are the same as for the standard Slim Cylinder.

## Seals Note: Seals cannot be replaced.

Parts	Rod seal	Lock piston seal	Lock cover gasket
Bore mm	Quantity	1	1
20	GYH-9	MYN-5	—
25	GYH-11	MYN-5	—
32	—	MYN-10A	S18
40	—	MYN-10A	S18
50	—	MYN-16	S22.4
63	—	MYN-16	S22.4

Other than the items listed above, they are the same as for the standard Slim Cylinder.

## Mass

Bore size mm [in.]	Zero stroke mass						Additional mass for each 1mm [0.0394in.] stroke	Mass of mounting bracket				
	-HL: Head side end keep			-RL: Rod side end keep				Foot bracket	Flange bracket	Pivot bracket	Y type knuckle	I type knuckle
	Basic type	Short head type	Pivot mounting type	Basic type	Short head type	Pivot mounting type						
20 [0.787]	0.16 [0.35]	0.15 [0.33]	—	0.15 [0.33]	0.14 [0.31]	—	0.0008 [0.0018]	0.14 [0.31]	0.08 [0.18]	0.06 [0.13]	0.042 [0.093]	0.035 [0.077]
25 [0.984]	0.21 [0.46]	0.20 [0.44]	—	1.20 [2.65]	0.19 [0.42]	—	0.0011 [0.0024]	0.16 [0.35]	0.08 [0.18]	0.06 [0.13]	0.075 [0.165]	0.070 [0.154]
32 [1.260]	0.35 [0.77]	0.33 [0.73]	—	0.34 [0.75]	0.32 [0.71]	—	0.0015 [0.0033]	0.19 [0.42]	0.10 [0.22]	0.14 [0.31]		
40 [1.575]	0.53 [1.17]	0.51 [1.12]	—	0.52 [1.15]	0.50 [1.10]	—	0.0024 [0.0053]	0.29 [0.64]	0.13 [0.29]	0.14 [0.31]	0.122 [0.269]	0.132 [0.291]
50 [1.969]	0.99 [2.18]	0.91 [2.01]	0.94 [2.07]	0.96 [2.12]	0.88 [1.94]	0.91 [2.01]	0.0028 [0.0062]	0.55 [1.21]	0.28 [0.62]	0.24 [0.53]		
63 [2.480]	1.32 [2.91]	1.26 [2.78]	1.28 [2.82]	1.29 [2.84]	1.22 [2.69]	1.25 [2.76]	0.0035 [0.0077]	0.73 [1.61]	0.37 [0.82]	0.24 [0.53]		

Calculation example: For head side end keep foot mounting type of 32mm bore size and 100mm stroke  
 $0.35 + 0.19 + (0.0015 \times 100) = 0.69\text{kg} [1.52\text{lb.}]$

# -HL Dimensions of Head Side End Keep Basic Type (mm)

●  $\phi 20 \sim \phi 40$

DAK [Bore size] × [Stroke] -HL

DAK [Bore size] -HL

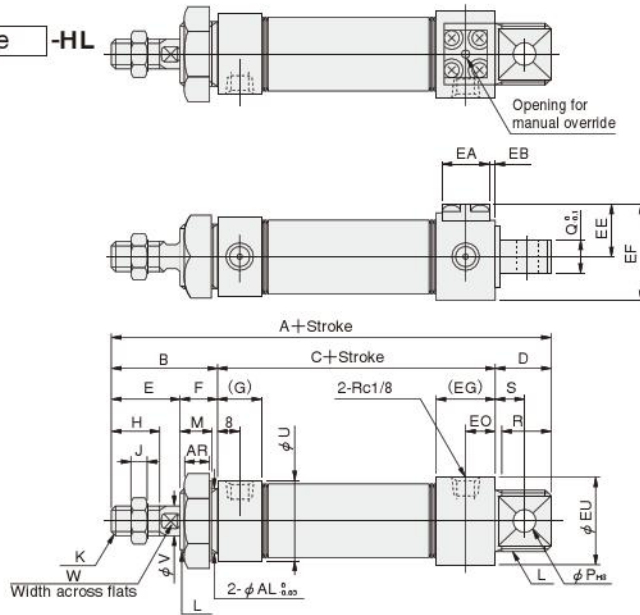
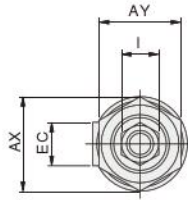

● Short head

DAK [Bore size] × [Stroke] -A-HL

SLIM-A

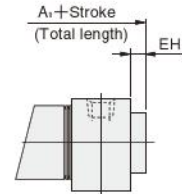

Bore size [in.]	Code	A	A <sub>1</sub>	B	C	D	E	F	G	H	I	J	K	L	M	P	Q	R	S	U	V	W
20 [0.787]		132	117	35	76	21	23	12	16	15	12	5	M8×1	M20×1.5	10	8	12	19	12	27	8	6
25 [0.984]		137	122	40	76	21	26	14	16	18	14	6	M10×1.25	M22×1.5	12	8	12	19	12	29	10	8
32 [1.260]		160	134	45	88	27	31	14	16	23	14	6	M10×1.25	M27×2	12	10	20	25	15	35	12	10
40 [1.575]		165	139	45	93	27	31	14	15	23	19	8	M14×1.5	M33×2	12	10	20	25	15	41.6	16	14

Bore size [in.]	Code	AR	AX	AY	AL	EA	EB	EC	EE	EF	EG	EH	EO	EU
20 [0.787]		7.5	31.2	27	20	16	—	16	17.5	32	16	6	8	29
25 [0.984]		9.5	34.6	30	22	16	—	16	18.5	36	16	6	8	35
32 [1.260]		9.5	41.6	36	27	24	2	25	22.5	40.5	26	1	14	35
40 [1.575]		9.5	47.3	41	33	24	4	25	25.5	46	31	1	16	41.6

●  $\phi 50, \phi 63$  DAK [Bore size] × [Stroke] -HL

DAK [Bore size] -HL

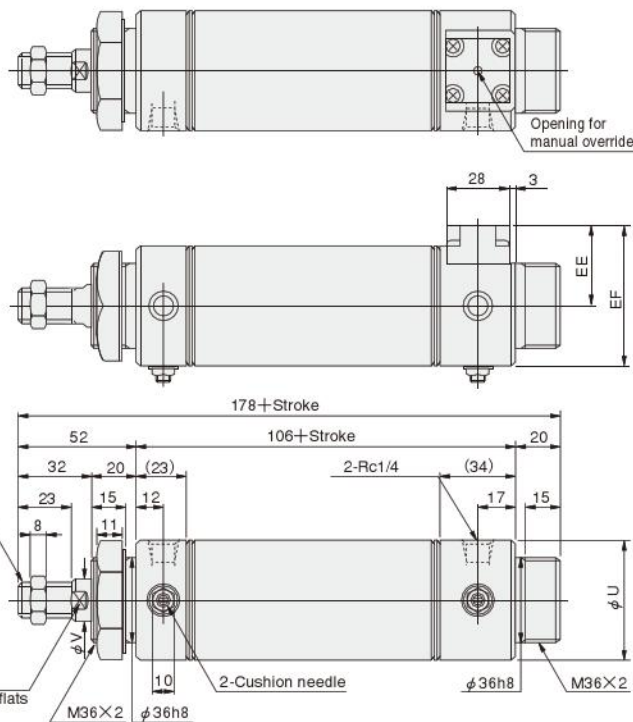
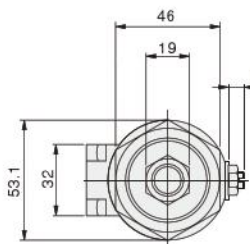

● Short head

DAK [Bore size] × [Stroke] -A-HL

SLIM-A

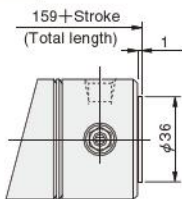

● Pivot mounting type head

DAK [Bore size] × [Stroke] -HL-8B

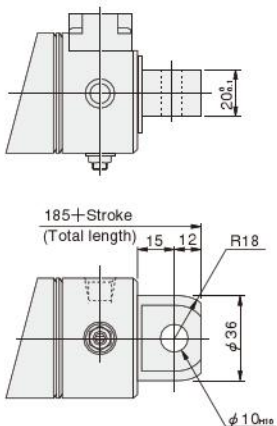

Bore size [in.]	Code	U	V	W	EE	EF
50 [1.969]		52	16	14	35.5	61.5
63 [2.480]		65.4	16	14	35.5	68.5

# -RL Dimensions of Rod Side End Keep Basic Type (mm)

●  $\phi 20 \sim \phi 40$

DAK [Bore size] × [Stroke] -RL

DAK [Bore size] -RL

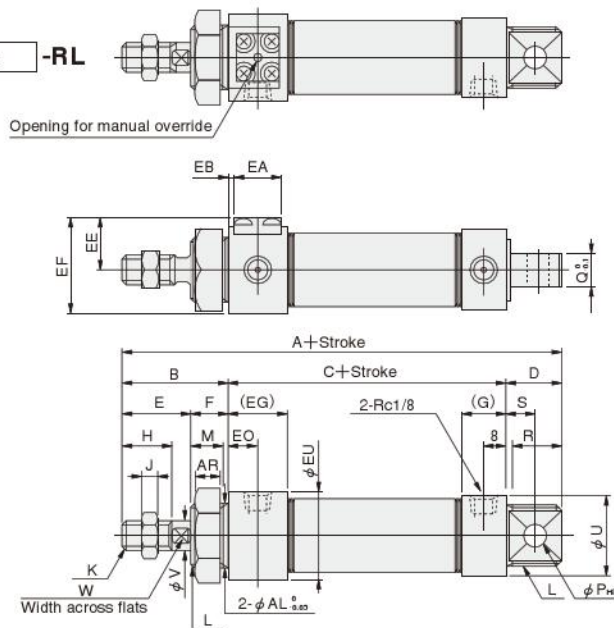

● Short head

DAK [Bore size] × [Stroke] -A-RL

SLIM-A

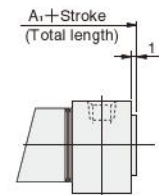

Bore mm [in.]	Code	A	A <sub>1</sub>	B	C	D	E	F	G	H	I	J	K	L	M	P	Q	R	S	U	V	W
20 [0.787]		132	112	35	76	21	23	12	16	15	12	5	M8×1	M20×1.5	10	8	12	19	12	27	8	6
25 [0.984]		137	117	40	76	21	26	14	16	18	14	6	M10×1.25	M22×1.5	12	8	12	19	12	29	10	8
32 [1.260]		160	134	45	88	27	31	14	16	23	14	6	M10×1.25	M27×2	12	10	20	25	15	35	12	10
40 [1.575]		165	139	45	93	27	31	14	15	23	19	8	M14×1.5	M33×2	12	10	20	25	15	41.6	16	14

Bore mm [in.]	Code	AR	AX	AY	AL	EA	EB	EC	EE	EF	EG	EO	EU
20 [0.787]		7.5	31.2	27	20	16	—	16	17.5	32	16	8	29
25 [0.984]		9.5	34.6	30	22	16	—	16	18.5	36	16	8	35
32 [1.260]		9.5	41.6	36	27	24	2	25	22.5	40.5	26	14	35
40 [1.575]		9.5	47.3	41	33	24	4	25	25.5	46	31	16	41.6

●  $\phi 50, \phi 63$  DAK [Bore size] × [Stroke] -RL

DAK [Bore size] -RL

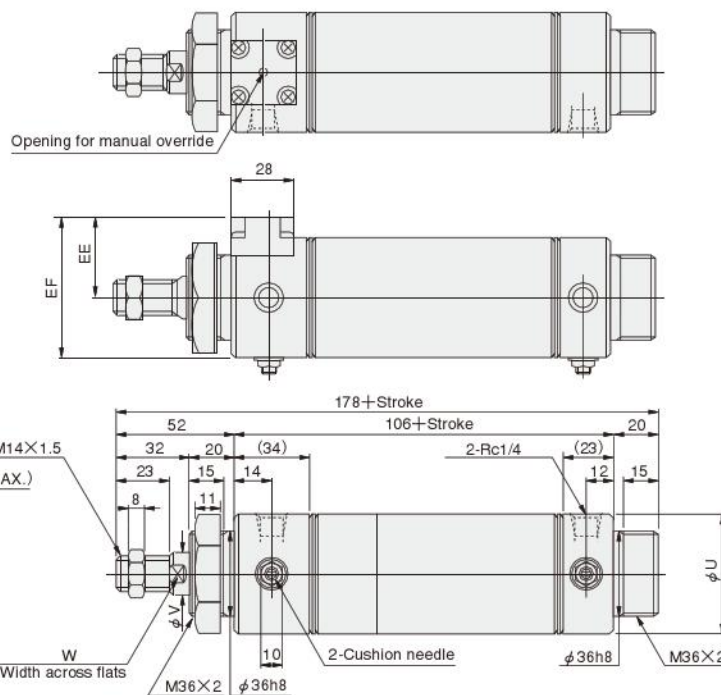

● Short head

DAK [Bore size] × [Stroke] -A-RL

SLIM-A

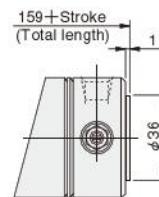

● Pivot mounting type head

DAK [Bore size] × [Stroke] -RL-8B

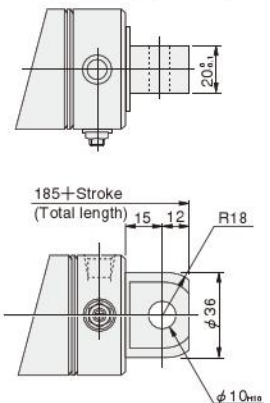

Bore mm [in.]	Code	U	V	W	EE	EF
50 [1.969]		52	16	14	35.5	61.5
63 [2.480]		65.4	16	14	35.5	68.5

# Operating Principle

## Keep

When the piston reaches the end of the stroke, and the head side is completely exhausted, spring force causes the lock piston to engage, and automatically keep the end of stroke position.



## Release

Supplying compressed air to the port on the locking mechanism side pushes up the lock piston and releases the lock. When the lock is released, the by-pass air passage opens to supply compressed air to the piston side.

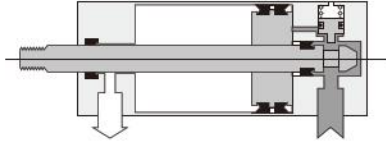

# Mounting Location of Sensor Switch

When the sensor switch is mounted in the location shown in the diagram (figures in the table are reference values), the magnet comes to the sensor switch's maximum sensing location at the end of the stroke.

● Air cylinder

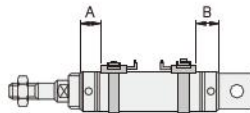

## ● -HL: Head side end keep

mm [in.]

Sensor switch model	Bore size Code	Air cylinder					
		20 [0.787]	25 [0.984]	32 [1.260]	40 [1.575]	50 [1.969]	63 [2.480]
ZG530 □	A	27 [1.063]	27 [1.063]	27 [1.063]	27 [1.063]	36 [1.417]	36 [1.417]
ZG553 □	B	27 [1.063]	27 [1.063]	39 [1.535]	44 [1.732]	47 [1.850]	47 [1.850]
CS □ M	A	27 [1.063]	27 [1.063]	27 [1.063]	27 [1.063]	36 [1.417]	36 [1.417]
	B	27 [1.063]	27 [1.063]	39 [1.535]	44 [1.732]	47 [1.850]	47 [1.850]
CS □ F	A	24 [0.945]	24 [0.945]	24 [0.945]	24 [0.945]	34 [1.339]	34 [1.339]
	B	24 [0.945]	24 [0.945]	38 [1.496]	41 [1.614]	46 [1.811]	46 [1.811]

## ● -RL: Rod side end keep

mm [in.]

Sensor switch model	Bore size Code	Air cylinder					
		20 [0.787]	25 [0.984]	32 [1.260]	40 [1.575]	50 [1.969]	63 [2.480]
ZG530 □	A	27 [1.063]	27 [1.063]	39 [1.535]	44 [1.732]	47 [1.850]	47 [1.850]
ZG553 □	B	27 [1.063]	27 [1.063]	27 [1.063]	27 [1.063]	36 [1.417]	36 [1.417]
CS □ M	A	27 [1.063]	27 [1.063]	39 [1.535]	44 [1.732]	47 [1.850]	47 [1.850]
	B	27 [1.063]	27 [1.063]	27 [1.063]	27 [1.063]	36 [1.417]	36 [1.417]
CS □ F	A	24 [0.945]	24 [0.945]	38 [1.496]	41 [1.614]	46 [1.811]	46 [1.811]
	B	24 [0.945]	24 [0.945]	24 [0.945]	24 [0.945]	34 [1.339]	34 [1.339]



### Control circuit

For control of Slim End Keep Cylinders, we recommend the use of 2-position, 4-, 5-port valves. Avoid the use of a control circuit of exhaust centers with 3-position valves or other control circuits that exhaust air from 2 delivery ports.

- Notes:
1. It is dangerous to supply air to a connection port on a side with a locking mechanism while already exhausted, because the piston rod could suddenly extend (or retract). In addition, since it could also cause galling of the lock piston and piston rod, resulting in defective operation. Always supply air to the connection port on the opposite side to ensure that back pressure is applied.
  2. When restarting operations after air has been exhausted from the cylinder due to completion of operations or to an emergency stop, always start by supplying air to the connection port on the opposite side of the locking mechanism.



### Manual operation

While the locking mechanism is normally released automatically through cylinder operations, it can also be released manually. For manual release, insert an M3 × 0.5 (M2.5×0.45 for  $\phi 16$ ) screw that has 30mm [1.18in.] below head length into the opening for manual override, thread it in about 3 turns into the internal lock piston, and then pull up the screw. To maintain the manual override for adjustment, etc., thread the locknut onto the screw and, with the locking mechanism in a released state, tighten the locknut against the cylinder.

- Notes:
1. It is dangerous to release the lock when a load (weight) is present on the piston rod, because it may cause a sudden fall or cause the unintended piston rod's extension (or retraction). In this case, always supply air to the connection port opposite the one adjacent to the locking mechanism before releasing the locking mechanism.
  2. If the locking mechanism cannot easily be released even with manual override, it could be the result of galling of the lock piston and piston rod. In this case, supply air to the connection port opposite the one adjacent to the locking mechanism before releasing the locking mechanism.



### General precautions

#### Media

1. Use air for the media. For the use of any other media, consult us.
2. Air used for the cylinder should be clean air that contains no deteriorated compressor oil, etc. Install an air filter (filtration of a minimum 40  $\mu\text{m}$ ) near the cylinder or valve to remove collected liquid or dust. In addition, drain the air filter periodically.  
Collected liquid or dust entering the cylinder may cause improper operation.

#### Lubrication

The product can be used without lubrication, if lubrication is required, use Turbine Oil Class 1 (ISO VG32) or equivalent.  
Avoid using spindle oil or machine oil.

#### Atmosphere

1. Because water, oil, dust, etc., entering the opening for manual override may cause defective locks or other erratic operation. If using in locations subject to dripping water, dripping oil etc., or to large amounts of dust, use a cover to protect the unit.
2. The product cannot be used when the media or ambient atmosphere contains any of the substances listed below.  
Organic solvents, phosphate ester type hydraulic oil, sulphur dioxide, chlorine gas, or acids, etc.

# OPTIONAL ROD END SHAPE PATTERNS

Use an order form of rod end pattern and fill the items on the selected one from among 28 types of optional patterned shapes to obtain made-to-order cylinders of non-standard rod end shapes.

The shapes can be applied to the entire Slim cylinders series with the exception of square rod cylinders and cylinders with bellows. For the order form containing the optional patterned shapes, consult us.

## Order Codes

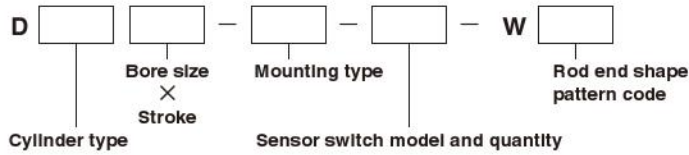

## Piston Rod End Shape Pattern Diagram (28 Types)

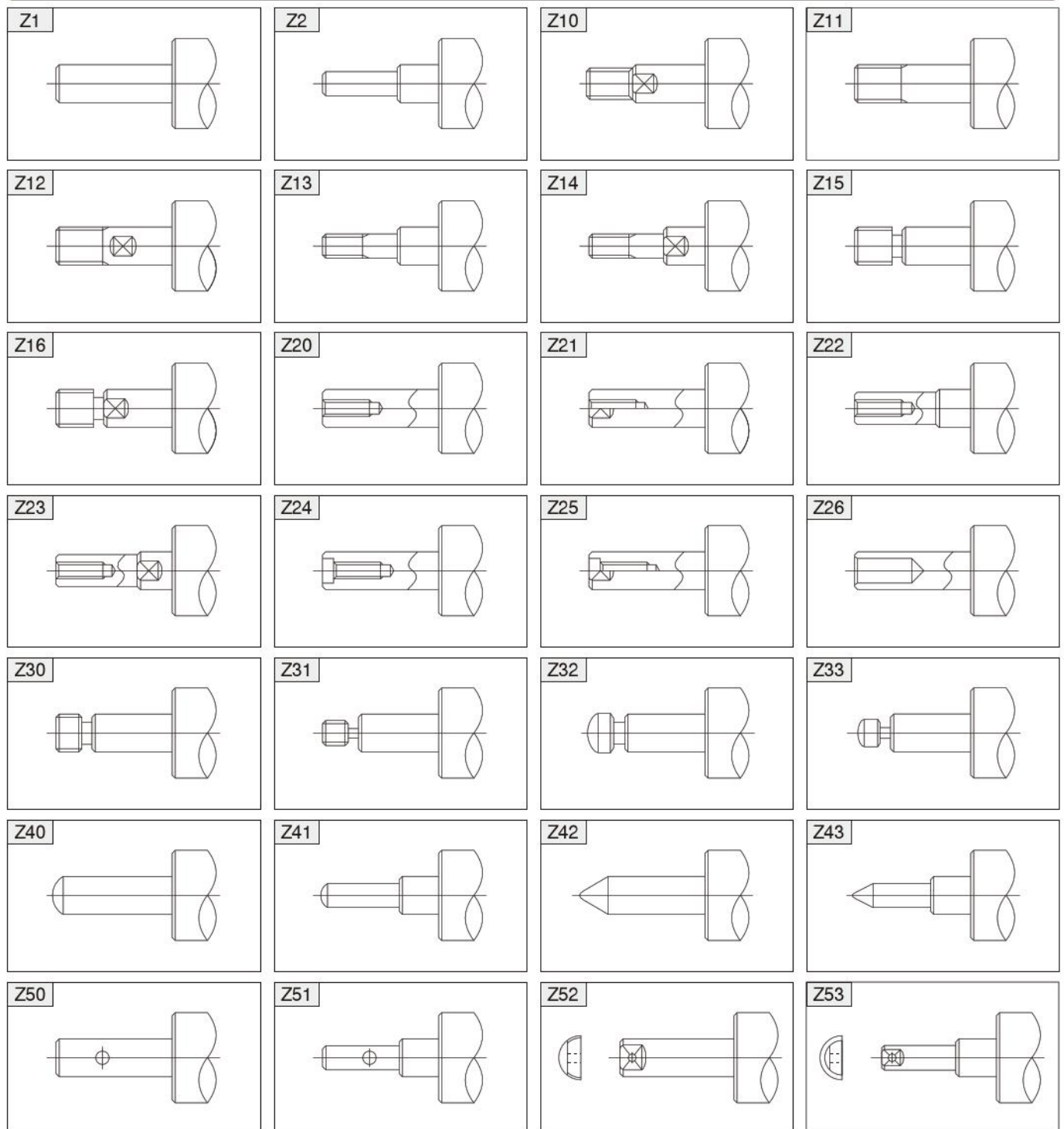

# SENSOR SWITCHES

## Solid State Type, Reed Switch Type

- Since a magnet is already standard on the Slim cylinders series<sup>Note</sup>, mounting a sensor switch will enable use in sensor switch applications.

Note: Except the heat resistant specification cylinder.

### Symbol



### Order Codes

- Order codes for sensor switches mounted on the Slim cylinders

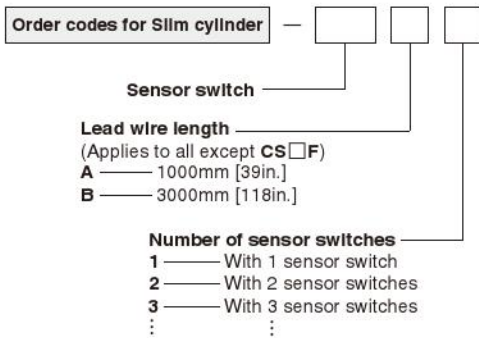

Sensor switch	For	with indicator lamp	
ZG530	φ16~φ63	Yes	DC10~30V
ZG553	φ16~φ63	Yes	DC4.5~28V
CS3M	φ16~φ63	Yes	DC10~30V
CS4M	φ16~φ63	Yes	AC85~230V
CS5M	φ16~φ63	No	DC10~30V
CS2F	φ20~φ63	Yes	AC85~115V
CS3F	φ20~φ63	Yes	DC3~30V
CS4F	φ20~φ63	Yes	AC85~115V
CS5F	φ20~φ63	No	DC3~30V

- Order codes for sensor switch only

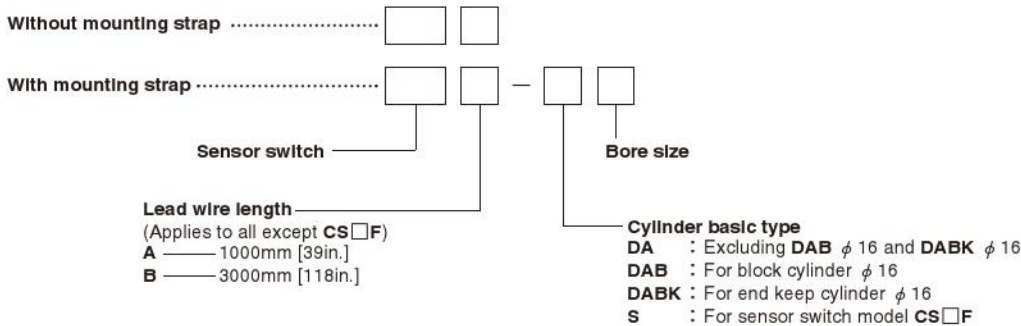

- Order codes for mounting strap only

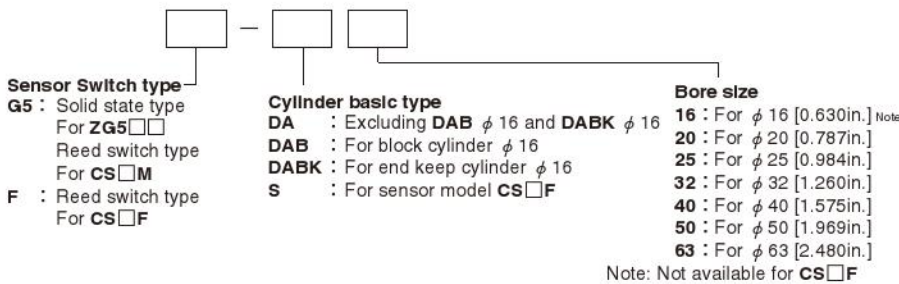

## Minimum Cylinder Strokes When Using Sensor Switches

Sensor switch model	Bore size	2 pcs. mounting		1 pc. mounting
		Along a straight line	In staggered positions	
		mm		
ZG530	16	20	10	10
ZG553	20~63	20	10	10
CS□M	16~63	20	15	15
CS□F	20~63	40	21	15

### ● Two pieces mounting ● One piece mounting

● When mounted in-line

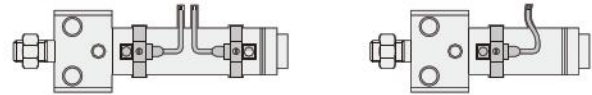

● When mounted in staggered positions

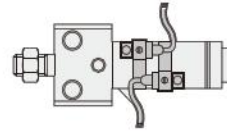

## Sensor Switch Operating Range, Response Differential, and Maximum Sensing Location

### ● Operating range : $\ell$

The distance the piston travels in one direction, while the switch is in the ON position.

### ● Response differential : C

The distance between the point where the piston turns the switch ON and the point where the switch is turned OFF as the piston travels in the opposite direction.

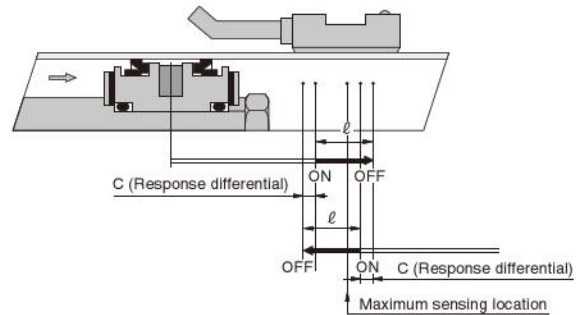

Item	Bore size	mm [in.]						
		16 [0.630]	20 [0.787]	25 [0.984]	32 [1.260]	40 [1.575]	50 [1.969]	63 [2.480]
Operating range : $\ell$	ZG530□	2.5~4.1 [0.098~0.161]	2.5~4.2 [0.098~0.165]	2.6~4.3 [0.102~0.169]	3.0~4.8 [0.118~0.189]	3.1~5.0 [0.122~0.197]	3.3~5.4 [0.130~0.213]	3.5~5.7 [0.138~0.224]
	ZG553□	—	—	—	—	—	—	—
	CS□M	6.7~7 [0.264~0.276]	7~8.5 [0.276~0.335]	7~8.5 [0.276~0.335]	8~9 [0.315~0.354]	9~10.5 [0.354~0.413]	7~8 [0.276~0.315]	8~9.5 [0.315~0.374]
	CS□F	—	7~8.5 [0.276~0.335]	8.5~10 [0.335~0.394]	9~10.5 [0.354~0.413]	10.5~12 [0.413~0.472]	9~10 [0.354~0.394]	9~10.5 [0.354~0.413]
Response differential : C	ZG530	0.7 [0.028] or less	0.7 [0.028] or less	0.8 [0.031] or less	0.7 [0.028] or less	0.8 [0.031] or less	0.8 [0.031] or less	0.8 [0.031] or less
	ZG553	0.7 [0.028] or less	0.7 [0.028] or less	0.8 [0.031] or less	0.7 [0.028] or less	0.8 [0.031] or less	0.8 [0.031] or less	0.8 [0.031] or less
	CS□M	1 [0.039] or less	1 [0.039] or less	1 [0.039] or less	1 [0.039] or less	1 [0.039] or less	1.2 [0.047] or less	1.2 [0.047] or less
	CS□F	—	1.5 [0.059] or less	1.5 [0.059] or less	1.5 [0.059] or less	1.5 [0.059] or less	2 [0.079] or less	1.5 [0.059] or less
Maximum sensing location	ZG530, ZG553 <sup>Note 1</sup>	11 [0.433]	11 [0.433]	11 [0.433]	11 [0.433]	11 [0.433]	11 [0.433]	11 [0.433]
	CS□M <sup>Note 1</sup>	11 [0.433]	11 [0.433]	11 [0.433]	11 [0.433]	11 [0.433]	11 [0.433]	11 [0.433]
	CS□F <sup>Note 2</sup>	—	16 [0.630]	16 [0.630]	16 [0.630]	16 [0.630]	16 [0.630]	16 [0.630]

Remark: Figures in the table above are reference values.

Notes: 1. Figures are lengths measured from the switch's opposite end side to the lead wire.

2. Figures are lengths measured from the connector side's end surface to the lead wire.

# Mounting Location of End of Stroke Detection Sensor Switch

When the sensor switch is mounted in the location shown in the diagram (figures in the table are reference values), the magnet comes to the sensor switch's maximum sensing location at the end of the stroke.

## ● Air cylinder, Low hydraulic cylinder, Valpack cylinder

● Air cylinder, Low hydraulic cylinder ● Valpack cylinder

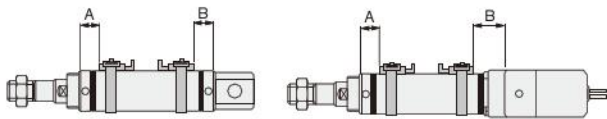

		mm [in.]									
Sensor switch model	Bore size Code	Air cylinder, Low hydraulic cylinder					Valpack cylinder				
		20	25	32	40	50	63	20	25	32	40
ZG530□ ZG553□	A	27 [1.063]	27 [1.063]	27 [1.063]	27 [1.063]	36 [1.417]	36 [1.417]	27 [1.063]	27 [1.063]	27 [1.063]	27 [1.063]
	B	27 [1.063]	27 [1.063]	27 [1.063]	27 [1.063]	36 [1.417]	36 [1.417]	39 [1.535]	39 [1.535]	39 [1.535]	44 [1.732]
CS□M	A	27 [1.063]	27 [1.063]	27 [1.063]	27 [1.063]	36 [1.417]	36 [1.417]	27 [1.063]	27 [1.063]	27 [1.063]	27 [1.063]
	B	27 [1.063]	27 [1.063]	27 [1.063]	27 [1.063]	36 [1.417]	36 [1.417]	39 [1.535]	39 [1.535]	39 [1.535]	44 [1.732]
CS□F	A	22 [0.866]	22 [0.866]	22 [0.866]	22 [0.866]	32 [1.260]	32 [1.260]	22 [0.866]	22 [0.866]	22 [0.866]	22 [0.866]
	B	22 [0.866]	22 [0.866]	22 [0.866]	22 [0.866]	32 [1.260]	32 [1.260]	34 [1.339]	34 [1.339]	34 [1.339]	39 [1.535]

## ● Single acting cylinder

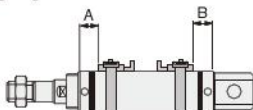

		mm [in.]				
Sensor switch model	Code	Stroke	Bore size			
			20 [0.787]	25 [0.984]	32 [1.260]	40 [1.575]
ZG530□ ZG553□ CS□M	A	0~25	35 [1.378]	36 [1.417]	35 [1.378]	37 [1.457]
		26~50	52 [2.047]	49 [1.929]	49 [1.929]	53 [2.087]
		51~75	72 [2.835]	71 [2.795]	72 [2.835]	68 [2.677]
		76~100	—	84 [3.307]	86 [3.386]	95 [3.740]
		101~125	—	—	—	110 [4.331]
		126~150	—	—	—	125 [4.921]
CS□F	A	0~25	30 [1.181]	31 [1.220]	30 [1.181]	32 [1.260]
		26~50	47 [1.850]	44 [1.732]	44 [1.732]	48 [1.890]
		51~75	67 [2.638]	66 [2.598]	67 [2.638]	63 [2.480]
		76~100	—	79 [3.110]	81 [3.189]	90 [3.543]
		101~125	—	—	—	105 [4.134]
		126~150	—	—	—	120 [4.724]
CS□F	B	—	22 [0.866]	22 [0.866]	22 [0.866]	22 [0.866]

## ● Block cylinder

● Side mount

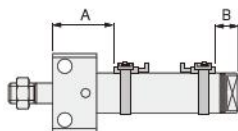

● Front mount

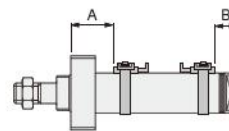

Mounting type		mm [in.]													
Bore size		Side mount					Front mount								
		16	20	25	32	40	50	63	16	20	25	32	40	50	63
ZG530□	A Rod side	32 [1.260]	39 [1.535]	41 [1.614]	47 [1.850]	57 [2.244]	67 [2.638]	67 [2.638]	23 [0.906]	27 [1.063]	27 [1.063]	27 [1.063]	29 [1.142]	37 [1.457]	37 [1.457]
ZG553□	B Rod side	16 [0.630]	20 [0.787]	20 [0.787]	21 [0.827]	25 [0.984]	45 [1.772]	45 [1.772]	16 [0.630]	20 [0.787]	20 [0.787]	21 [0.827]	25 [0.984]	45 [1.772]	45 [1.772]
CS□M	A Rod side	32 [1.260]	39 [1.535]	41 [1.614]	47 [1.850]	57 [2.244]	66 [2.598]	66 [2.598]	23 [0.906]	27 [1.063]	27 [1.063]	27 [1.063]	29 [1.142]	36 [1.417]	36 [1.417]
	B Rod side	16 [0.630]	20 [0.787]	20 [0.787]	21 [0.827]	25 [0.984]	44 [1.732]	44 [1.732]	16 [0.630]	20 [0.787]	20 [0.787]	21 [0.827]	25 [0.984]	44 [1.732]	44 [1.732]
CS□F	A Rod side	—	36 [1.417]	38 [1.496]	44 [1.732]	52 [2.047]	64 [2.520]	64 [2.520]	—	24 [0.945]	24 [0.945]	24 [0.945]	24 [0.945]	34 [1.339]	34 [1.339]
	B Rod side	—	17 [0.669]	17 [0.669]	18 [0.709]	20 [0.787]	42 [1.654]	42 [1.654]	—	17 [0.669]	17 [0.669]	18 [0.709]	22 [0.866]	42 [1.654]	42 [1.654]

SLIM CYLINDERS

## Moving Sensor Switch

- ZG530
- ZG553
- CS  M

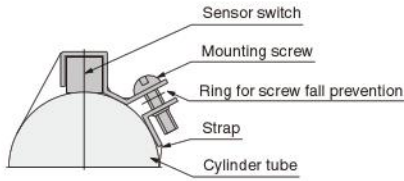

- Loosening the mounting screw allows the sensor switch to be moved freely along with the strap in the axial and circumferential direction. The sensor switch alone cannot be moved.
- To remove the sensor switch from the strap, first detach the strap from the cylinder tube and then remove the sensor switch from the strap.
- Tighten the mounting screw with a tightening torque of 49N·cm [4.3in·lbf].

- CS  F

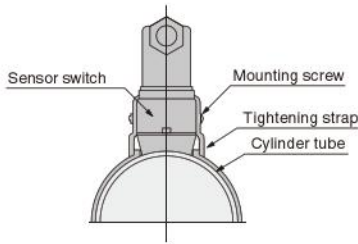

- Loosening the mounting screw allows the sensor switch to be moved freely in the axial and circumferential direction.
- Slightly loosening the mounting screw allows fine adjustment of the lead switch only, up to 5mm [0.2in.] in the axial direction. Tighten the mounting screw with a tightening torque of 68.6N·cm [6.1in·lbf].

## Dimensions of Sensor Switch (mm)

- ZG530
- ZG553
- CS  M

φ 16

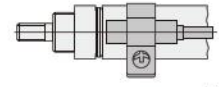
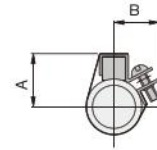

Lead wire length  
A: 1000mm [39in.]  
B: 3000mm [118in.]

φ 20 ~ φ 63

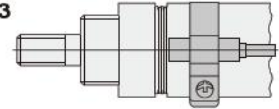
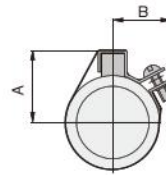

Lead wire length  
A: 1000mm [39in.]  
B: 3000mm [118in.]

mm [in.]		
Bore	Code	
16	16	15
[0.630]	[0.630]	[0.591]
20	19	17
[0.787]	[0.748]	[0.669]
25	20.5	17.5
[0.984]	[0.807]	[0.689]
32	25	19
[1.260]	[0.984]	[0.748]
40	29	—*
[1.575]	[1.142]	
50	34	—*
[1.969]	[1.339]	
63	41	—*
[2.480]	[1.614]	

\* At φ 40 or larger, dimension B is the radius of the cylinder tube. Therefore, the protrusion in the B direction of the mounting section disappears.

- CS  F

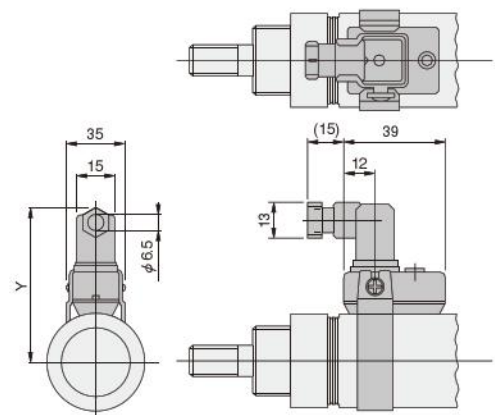

mm [in.]	
Bore	Code
20	59
[0.787]	[2.323]
25	61.5
[0.984]	[2.421]
32	65
[1.260]	[2.559]
40	69
[1.575]	[2.717]
50	76
[1.969]	[2.992]
63	83
[2.480]	[3.268]

# ROD END ACCESSORIES

## Option

### Dimensions

#### ● $\phi 16$

#### ● Y type

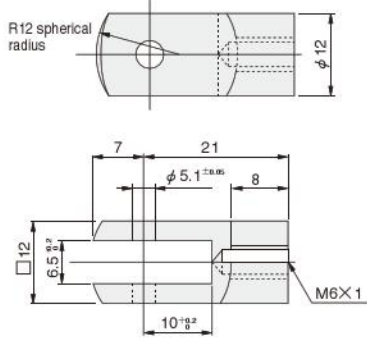

#### Pin for Y type knuckle

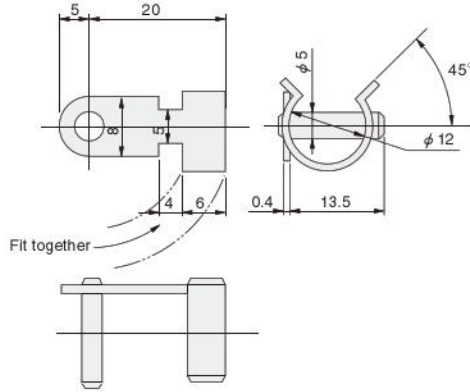

#### ● I type

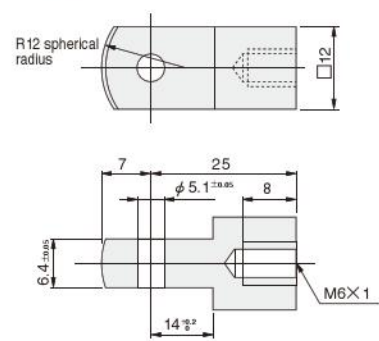

#### ● $\phi 20 \sim \phi 63$

#### ● Y type

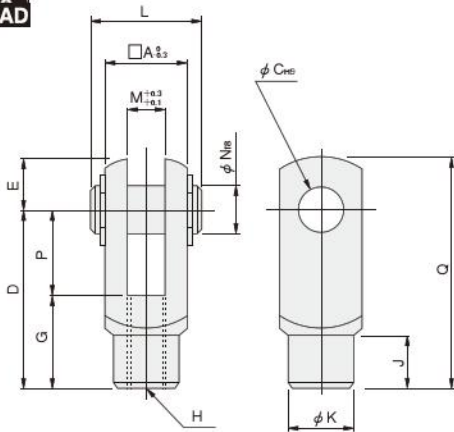

#### ● I type

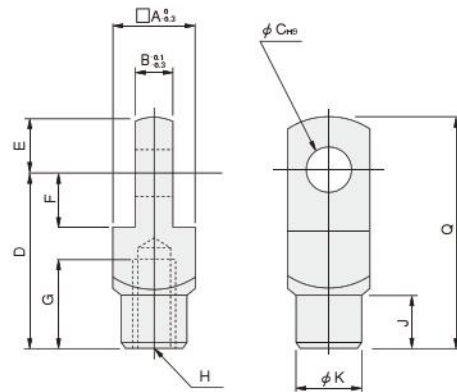

mm [in.]

Bore	Code	A	B	C	D	E	F	G	H	J	K	L	M	N	P	Q
20 [0.787], 25 [0.984]*		16	8	8	30	10	11	15	M8×1	10	14	21	8	8	15	40
25 [0.984], 32 [1.260]		19	10	10	40	12	13	20	M10×1.25	12	16	25	10	10	20	52
40 [1.575], 50 [1.969], 63 [2.480]		24	14	10	45	12	13	25	M14×1.5	15	22	30	14	10	20	57

Note: Items marked with ※ are for the square rod cylinders.

# BELLOWS, MOUNTING BRACKETS

CAD SLIM-J

**Dimensions** (For brake cylinders with bellows, see p.367.)

●  $\phi 20 \sim \phi 40$

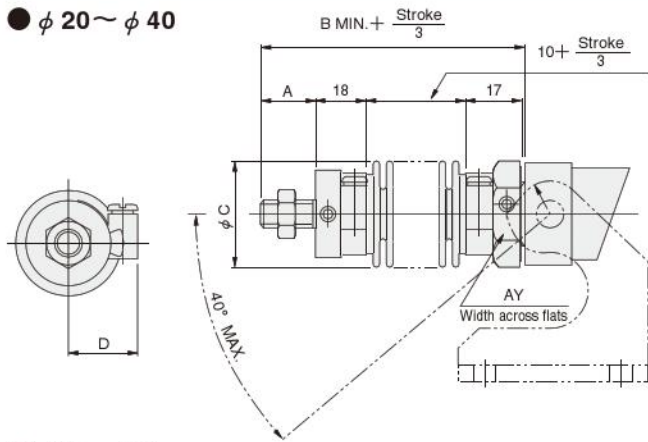

Bore	Code	A	B	C	D	AY
20	[0.787]	15 [0.591]	63 [2.480]	35 [1.378]	23 [0.906]	27 [1.063]
25	[0.984]	18 [0.709]	66 [2.598]	35 [1.378]	23 [0.906]	30 [1.181]
32	[1.260]	23 [0.906]	71 [2.795]	40 [1.575]	26 [1.024]	36 [1.417]
40	[1.575]	23 [0.906]	71 [2.795]	48 [1.890]	29 [1.142]	41 [1.614]

Note: Supporting brackets for the rod trunnion type with bellows should be mounted in the direction opposite to the case of no bellows shown in the diagram.

●  $\phi 50, \phi 63$

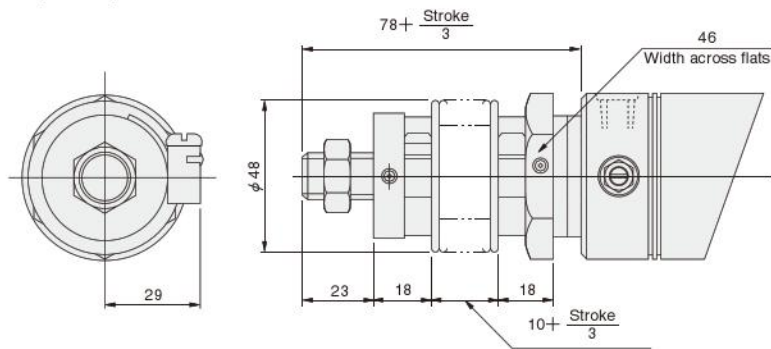

## Mass of Slim Cylinder with Bellows

Bore size mm [in.]	Zero stroke mass				Additional mass for each 1mm [0.0394in.] stroke
	Standard head	Short head	Pivot mounting type	Trunnion type	
20 [0.787]	0.25 [0.55] (0.23 [0.51])	0.24 [0.53] (0.22 [0.49])	—	0.44 [0.97]	0.0009 [0.0020]
25 [0.984]	0.29 [0.64] (0.27 [0.60])	0.28 [0.62] (0.26 [0.57])	—	0.47 [1.04]	0.0013 [0.0029]
32 [1.260]	0.43 [0.95] (0.40 [0.88])	0.41 [0.90] (0.38 [0.84])	—	0.60 [1.32]	0.0018 [0.0040]
40 [1.575]	0.62 [1.37] (0.56 [1.23])	0.58 [1.28] (0.52 [1.15])	—	0.78 [1.72]	0.0029 [0.0064]
50 [1.969]	1.03 [2.27]	0.98 [2.16]	0.95 [2.09]	—	0.0033 [0.0073]
63 [2.480]	1.36 [3.00]	1.32 [2.91]	1.29 [2.84]	—	0.0038 [0.0084]

Note: Figures in parentheses ( ) are for the cylinder with variable cushion.

# Order Codes for Mounting Bracket

## (1) Foot mounting bracket

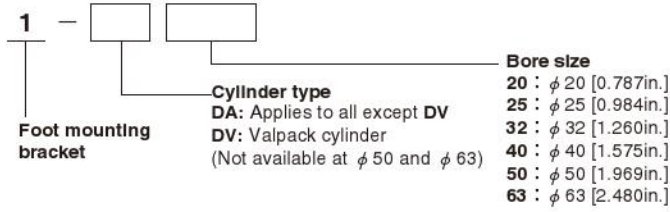

## (2) Flange mounting bracket

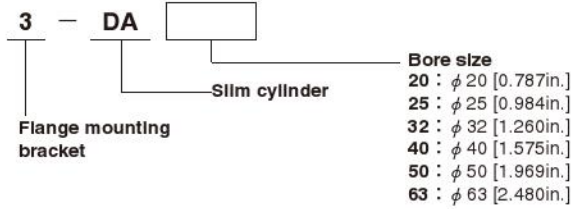

## (3) Pivot mounting type supporting bracket

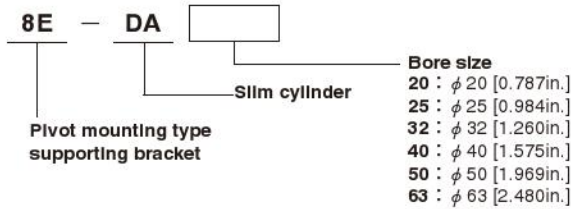

## (4) Head trunnion bracket

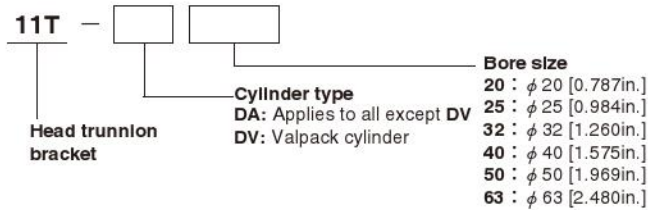

## (5) Rod trunnion bracket

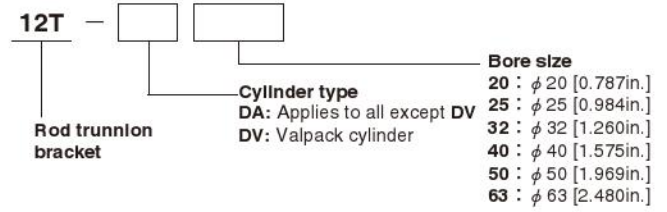

## (6) Y type knuckle

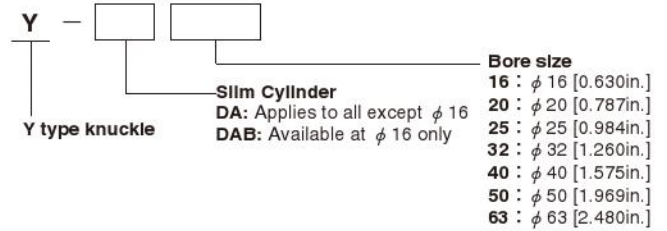

## (7) I type knuckle

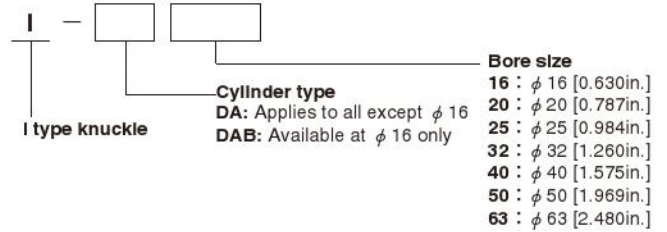

SLIM CYLINDERS