



# SENSOR SWITCHES

## CONTENTS

### Solid State Type Sensor Switch

<b>ZC130</b> □, <b>ZC153</b> □	1545
<b>ZC230</b> □, <b>ZC253</b> □	1546
<b>ZC330</b> □, <b>ZC353</b> □	1547
<b>ZG530</b> □, <b>ZG553</b> □	1548
<b>ZC630</b> □, <b>ZC653</b> □	1549
<b>ZE135</b> □, <b>155</b> □, <b>235</b> □, <b>255</b> □	1550
<b>ZE175</b> □, <b>ZE275</b> □	1551
<b>CS9H</b> □, <b>ZB430</b> □	1553

Points of Wiring Solid State Type Sensor Switches	1554
---	------

### Strong Magnetic Field Resistant Sensor Switch

<b>ZD136C</b>	1555
---------------	------

### Reed Switch Type Sensor Switch

<b>CS5T</b> □, <b>CS11T</b> □	1557
<b>ZC201</b> □, <b>ZC205</b> □	1558
<b>CS3M</b> □, <b>4M</b> □, <b>5M</b> □	1559
<b>CS3H</b> □, <b>4H</b> □, <b>5H</b> □	1560
<b>ZC301</b> □, <b>ZC305</b> □	1561
<b>ZC601</b> □, <b>ZC605</b> □	1562
<b>ZE101</b> □, <b>102</b> □, <b>201</b> □, <b>202</b> □	1563
<b>CS2F</b> , <b>3F</b> , <b>4F</b> , <b>5F</b>	1564
<b>CS2B</b> , <b>3B</b> , <b>4B</b> , <b>5B</b>	1565

Contact Protection for Reed Switch Type Sensor Switches	1566
---	------

# ZC130□, ZC153□



## Solid State Type Sensor Switch

### Applicable cylinders

- Knock cylinders double acting type ● Multi mount cylinders ● Pen cylinders ● DYNA cylinders ● SD cylinders ● TDA  $\phi$  6 [0.236in.]
- AMT ● ARTB ● ACY (For the intermediate stopper) ● ORV ● ORK  $\phi$  16 [0.630in.] ● RAP ● RAN ● Swing cylinders ● Air Hands CHDUL
- SHM

### Specifications

Item	Model	ZC130□	ZC153□
Wiring type		2-lead wire	3-lead wire
Power supply voltage		—	DC4.5~28V
Load voltage		DC10~28V	DC4.5~28V
Load current		4~50mA	100mA MAX.
Consumption current		—	10mA MAX. (DC24V)
Internal voltage drop <sup>Note 1</sup>		3.5V MAX.	0.5V MAX. (At 50mA load current)
Leakage current		1mA MAX. (DC24V)	50 $\mu$ A MAX. (DC24V)
Response time		1ms MAX.	
Insulation resistance		100M $\Omega$ MIN. (At DC500V Megger, between case and lead wire end)	
Dielectric strength		AC500V (50/60Hz) in 1 minute (Between case and lead wire end)	
Shock resistance <sup>Note 2</sup>		294.2m/s <sup>2</sup> [30G] (Non-repeated shock)	
Vibration resistance <sup>Note 2</sup>		88.3m/s <sup>2</sup> [9G] (Total amplitude 1.5mm [0.06in.], 10~55Hz)	
Environmental protection		IP67 (IEC standard), JIS C0920 (Water-proof type)	
Operation indicator		When ON: Red LED indicator lights up	
Lead wire <sup>Note 3</sup>		PVC 0.2SQ X 2-lead X $\ell$	PVC 0.2SQ X 3-lead X $\ell$
Ambient temperature		0~60°C [32~140°F]	
Storage temperature range		-10~70°C [14~158°F]	
Mass		20g [0.71oz.] (For lead wire length A: 1000mm)	

Notes: 1. The internal voltage drop depends on load current.

2. Measured by Koganei test standard.

3. Lead wire length  $\ell$ : A; 1000mm [39in.], B; 3000mm [118in.]

※ This product is not resistant to lightning surge of the EMC standard (EN61000-6-2 · EN60947-5-2).  
Prepare protection measures for lightning surge in the system.

### Internal Circuit

#### ZC130□

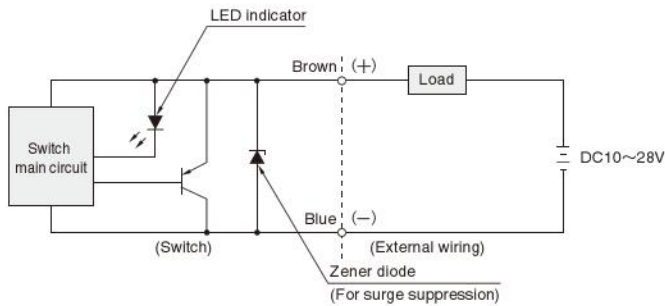

#### ZC153□

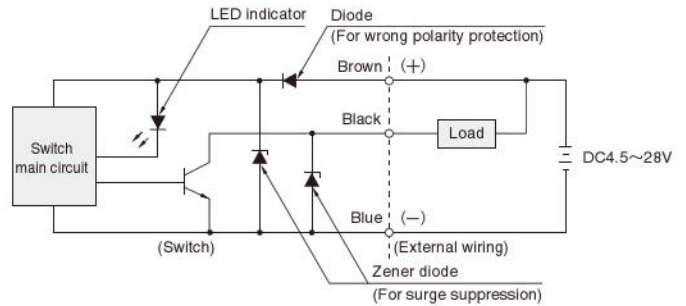

### Dimensions (mm)

#### ZC130□

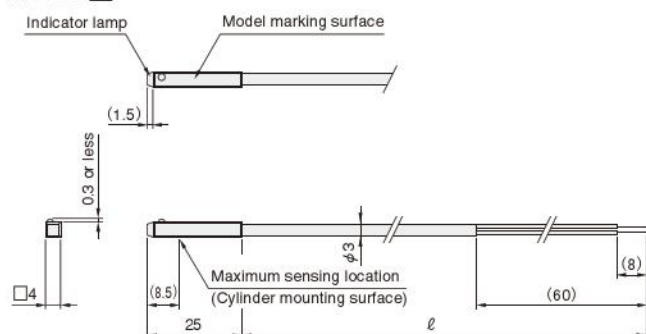

#### ZC153□

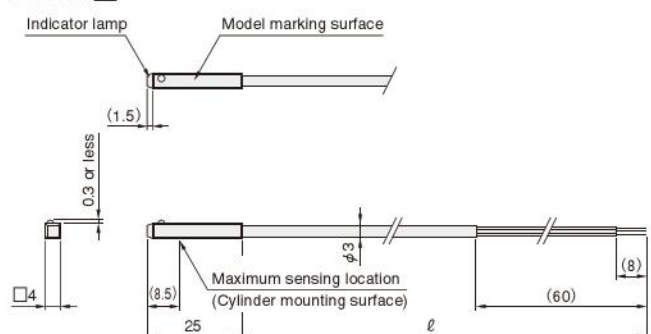

# ZC230 □, ZC253 □



## Solid State Type Sensor Switch

### Applicable cylinders

- Pen cylinders

### Specifications

Item	Model	ZC230 □	ZC253 □
Wiring type		2-lead wire	3-lead wire
Power supply voltage		—	DC4.5~28V
Load voltage		DC10~28V	DC4.5~28V
Load current		4~50mA	100mA MAX.
Consumption current		—	10mA MAX. (DC24V)
Internal voltage drop <sup>Note 1</sup>		3.5V MAX.	0.5V MAX. (At 50mA load current)
Leakage current		1mA MAX. (DC24V)	50μA MAX. (DC24V)
Response time		1ms MAX.	
Insulation resistance		100MΩ MIN. (At DC500V Megger, between case and lead wire end)	
Dielectric strength		AC500V (50/60Hz) in 1 minute (Between case and lead wire end)	
Shock resistance <sup>Note 2</sup>		294.2m/s <sup>2</sup> [30G] (Non-repeated shock)	
Vibration resistance <sup>Note 2</sup>		88.3m/s <sup>2</sup> [9G] (Total amplitude 1.5mm [0.06in.], 10~55Hz)	
Environmental protection		IP67 (IEC standard), JIS C0920 (Water-proof type)	
Operation indicator		When ON: Red LED indicator lights up	
Lead wire <sup>Note 3</sup>		PVC 0.2SQ X 2-lead X ℓ	PVC 0.2SQ X 3-lead X ℓ
Ambient temperature		0~60°C [32~140°F]	
Storage temperature range		-10~70°C [14~158°F]	
Mass		20g [0.71oz.] (For lead wire length A: 1000mm)	

Notes: 1. The internal voltage drop depends on load current.

2. Measured by Koganei test standard.

3. Lead wire length ℓ : A; 1000mm [39in.], B; 3000m [118in.]

※ This product is not resistant to lightning surge of the EMC standard (EN61000-6-2 · EN60947-5-2).

Prepare protection measures for lightning surge in the system.

### Internal Circuit

#### ZC230 □

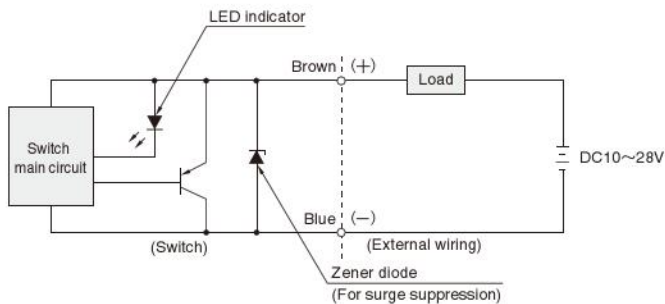

#### ZC253 □

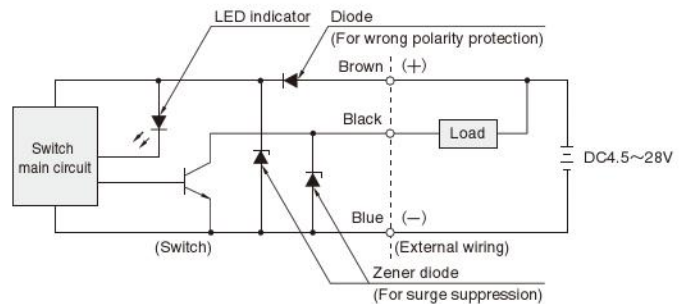

### Dimensions (mm)

#### ZC230 □

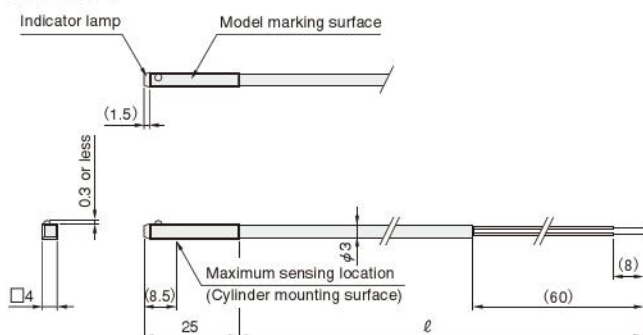

#### ZC253 □

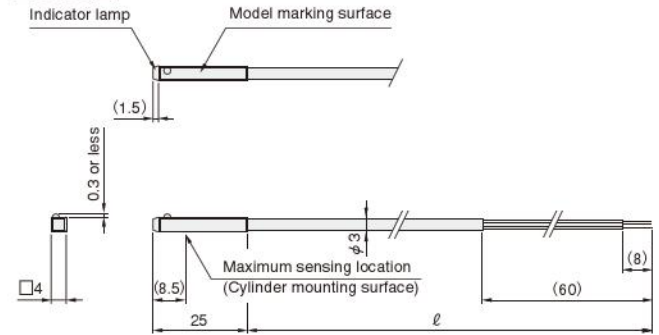

# ZC330 □, ZC353 □



## Solid State Type Sensor Switch

### Applicable cylinders

● AGTB ● AGTC

### Specifications

Item	Model	ZC330 □	ZC353 □
Wiring type		2-lead wire	3-lead wire
Power supply voltage		—	DC4.5~28V
Load voltage		DC10~28V	DC4.5~28V
Load current		4~50mA	100mA MAX.
Consumption current		—	10mA MAX.(DC24V)
Internal voltage drop <sup>Note 1</sup>		3.5V MAX.	0.5V MAX. (At 50mA load current)
Leakage current		1mA MAX. (DC24V)	50μA MAX.(DC24V)
Response time		1ms MAX.	
Insulation resistance		100MΩ MIN. (At DC500V Megger, between case and lead wire end)	
Dielectric strength		AC500V (50/60Hz) in 1 minute (Between case and lead wire end)	
Shock resistance <sup>Note 2</sup>		294.2m/s <sup>2</sup> [30G] (Non-repeated shock)	
Vibration resistance <sup>Note 2</sup>		88.3m/s <sup>2</sup> [9G] (Total amplitude 1.5mm [0.06in.], 10~55Hz)	
Environmental protection		IP67 (IEC standard), JIS C0920 (Water-proof type)	
Operation indicator		When ON: Red LED indicator lights up	
Lead wire <sup>Note 3</sup>		PVC 0.2SQ X 2-lead X ℓ	PVC 0.2SQ X 3-lead X ℓ
Ambient temperature		0~60°C [32~140°F]	
Storage temperature range		-10~70°C [14~158°F]	
Mass		20g [0.71oz.] (For lead wire length A: 1000mm)	

Notes: 1. The internal voltage drop depends on load current.

2. Measured by Koganei test standard.

3. Lead wire length ℓ : A; 1000mm [39in.], B; 3000m [118in.]

※ This product is not resistant to lightning surge of the EMC standard (EN61000-6-2 · EN60947-5-2).

Prepare protection measures for lightning surge in the system.

### Internal Circuit

#### ZC330 □

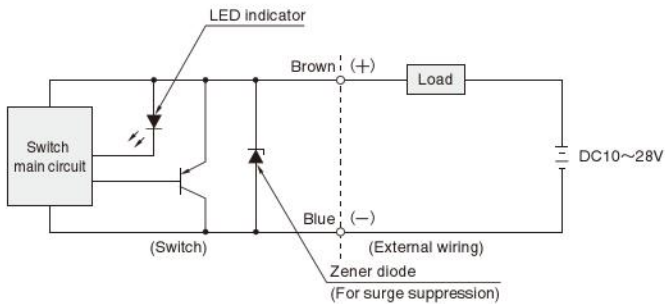

#### ZC353 □

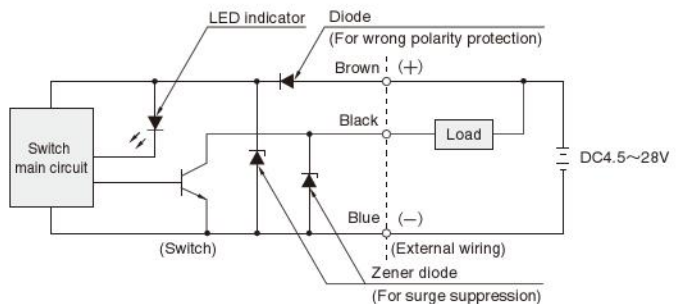

### Dimensions (mm)

#### ZC330 □

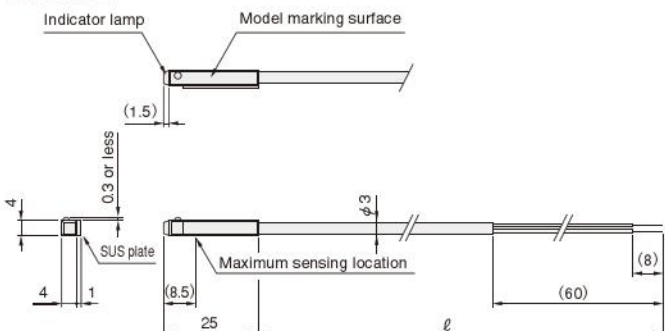

#### ZC353 □

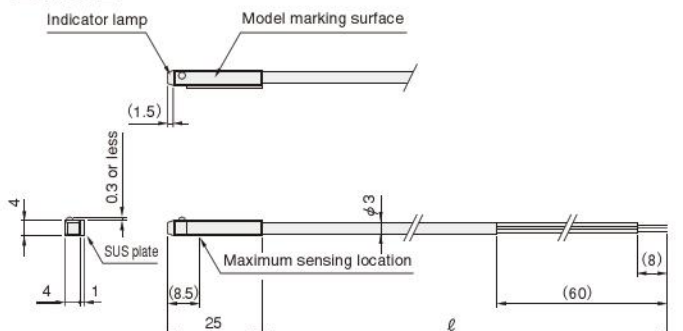

# ZG530 □, ZG553 □



## Solid State Type Sensor Switch

### Applicable cylinders

- Slim cylinders ● Twinport cylinders ● GA ● ORC ● ORCA ● ORGA ● ORK<sup>Note</sup> ● MRG ● RAK
- Swing cylinders ● Twist cylinders

Note: Excluding ORK  $\phi$  16 [0.630in.].

### Specifications

Item	Model	ZG530 □	ZG553 □
Wiring type		2-lead wire	3-lead wire
Power supply voltage		—	DC4.5~28V
Load voltage		DC10~28V	DC4.5~28V
Load current		4~50mA	100mA MAX.
Consumption current		—	10mA MAX. (DC24V)
Internal voltage drop <sup>Note 1</sup>		4.5V MAX.	0.5V MAX. (At 50mA load current)
Leakage current		1mA MAX. (DC24V at 25°C [77°F])	50 $\mu$ A MAX. (DC24V)
Response time		1ms MAX.	
Insulation resistance		100M $\Omega$ MIN. (At DC500V Megger, between case and lead wire end)	
Dielectric strength		AC500V (50/60Hz) in 1 minute (Between case and lead wire end)	
Shock resistance <sup>Note 2</sup>		294.2m/s <sup>2</sup> [30G] (Non-repeated shock)	
Vibration resistance <sup>Note 2</sup>		88.3m/s <sup>2</sup> [9G] (Total amplitude 1.5mm [0.06in.], 10~55Hz)	
Environmental protection		IP67 (IEC standard), JIS C0920 (Water-proof type)	
Operation indicator		When ON: Red LED indicator lights up	
Lead wire <sup>Note 3</sup>		PVC 0.2SQ X 2-lead X $\ell$	PVC 0.2SQ X 3-lead X $\ell$
Ambient temperature		0~60°C [32~140°F]	
Storage temperature range		-10~70°C [14~158°F]	
Mass		20g [0.71oz.] (For lead wire length A: 1000mm)	

Notes: 1. The internal voltage drop depends on load current.

2. Measured by Koganei test standard.

3. Lead wire length  $\ell$ : A; 1000mm [39in.], B; 3000m [118in.]

※ This product is not resistant to lightning surge of the EMC standard (EN61000-6-2 · EN60947-5-2). Prepare protection measures for lightning surge in the system.

### Internal Circuit

#### ZG530 □

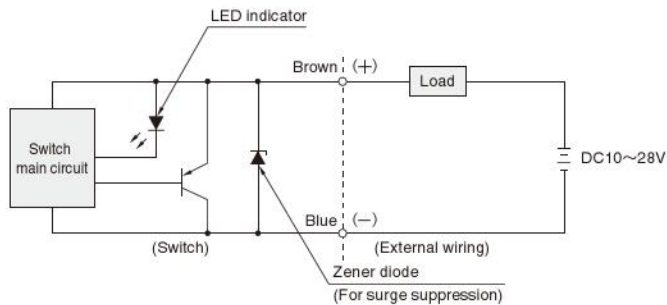

#### ZG553 □

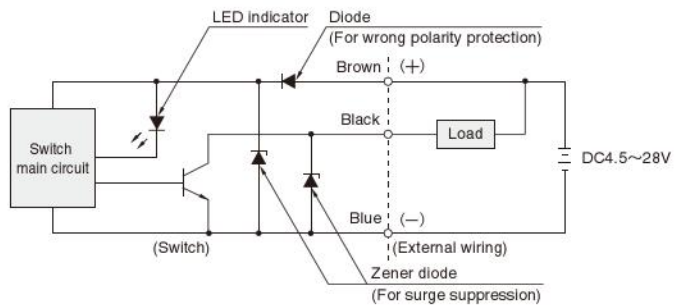

### Dimensions (mm)

#### ZG530 □

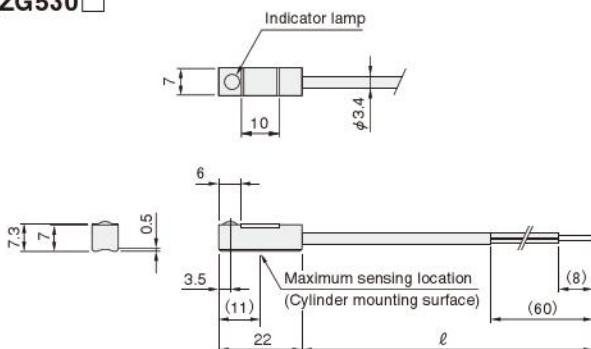

#### ZG553 □

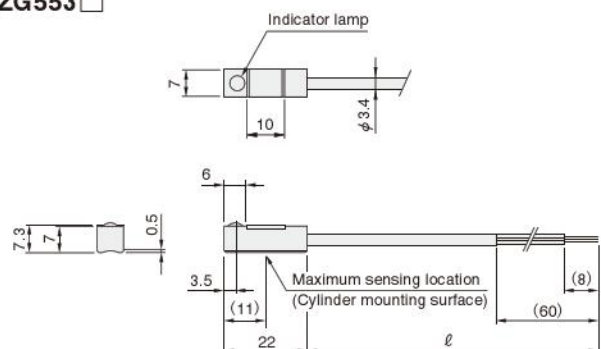

# ZC630 □, ZC653 □



## Solid State Type Sensor Switch

### Applicable cylinders

- Axis cylinders

### Specifications

Item	Model	ZC630 □	ZC653 □
Wiring type		2-lead wire	3-lead wire
Power supply voltage		—	DC4.5~28V
Load voltage		DC10~28V	DC4.5~28V
Load current		4~50mA	100mA MAX. (DC24V)
Consumption current		—	10mA MAX. (DC24V)
Internal voltage drop <sup>Note 1</sup>		3.5V MAX.	0.5V MAX. (At 50mA load current)
Leakage current		1mA MAX. (DC24V)	50μA MAX. (DC24V)
Response time		1ms MAX.	
Insulation resistance		100MΩ MIN. (At DC500V Megger, between case and lead wire end)	
Dielectric strength		AC500V (50/60Hz) in 1 minute (Between case and lead wire end)	
Shock resistance <sup>Note 2</sup>		294.2m/s <sup>2</sup> [30G] (Non-repeated shock)	
Vibration resistance <sup>Note 2</sup>		88.3m/s <sup>2</sup> [9G] (Total amplitude 1.5mm [0.06in.], 10~55Hz)	
Environmental protection		IP67 (IEC standard), JIS C0920 (Water-proof type)	
Operation indicator		When ON: Red LED indicator lights up	
Lead wire <sup>Note 3</sup>		PVC 0.2SQ X 2-lead X ℓ	PVC 0.2SQ X 3-lead X ℓ
Ambient temperature		0~60°C [32~140°F]	
Storage temperature range		-10~70°C [14~158°F]	
Mass		20g [0.71oz.] (For lead wire length A: 1000mm)	

Notes: 1. The internal voltage drop depends on load current.

2. Measured by Koganei test standard.

3. Lead wire length ℓ : A; 1000mm [39in.], B; 3000m [118in.]

※ This product is not resistant to lightning surge of the EMC standard (EN61000-6-2 · EN60947-5-2).

Prepare protection measures for lightning surge in the system.

### Internal Circuit

#### ZC630 □

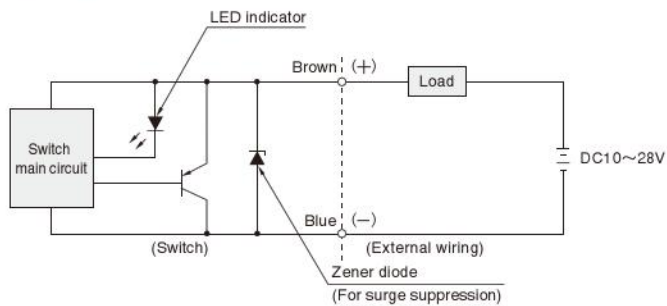

#### ZC653 □

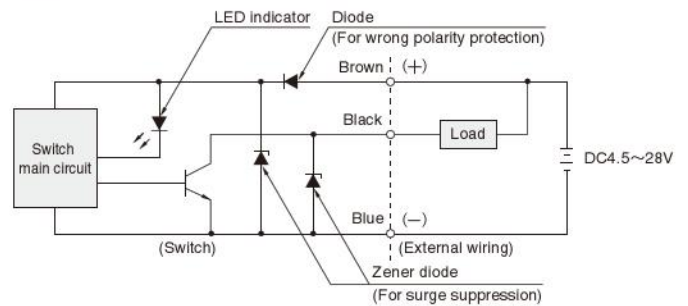

### Dimensions (mm)

#### ZC630 □

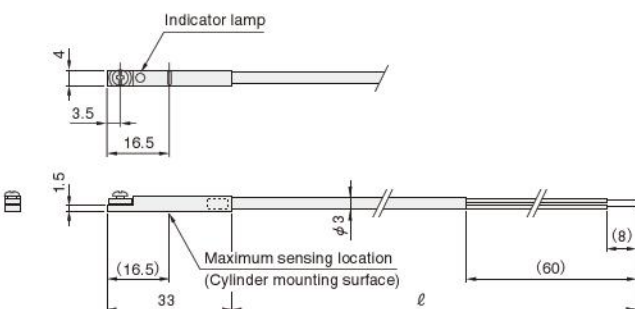

#### ZC653 □

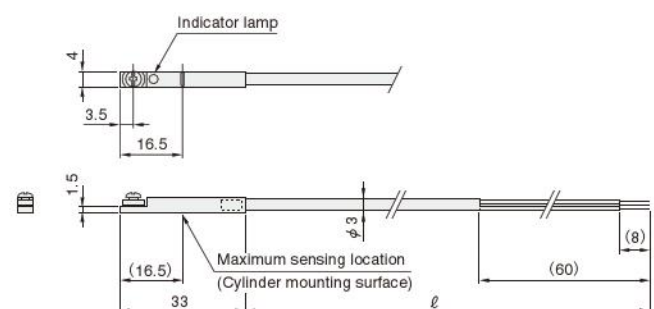

ZE135□, 155□, 235□, 255□



Solid State Type Sensor Switch



Applicable cylinders

- Mini bit cylinders ● Jig cylinders C series ● Jig cylinders JC series ● Mini guide sliders ● Jig cylinders with guides
- Twin rod cylinders B series ● Rod sliders ● Multi sliders ● Z sliders ● WS ● WT ● ACY<sup>Note1</sup> ● ACZ<sup>Note1</sup> ● Flat rodless cylinders<sup>Note1</sup> ● ORV<sup>Note1</sup> ● ORS, MRS<sup>Note1</sup> ● ORW, MRW<sup>Note1</sup> ● NHC1 series ● Air Hands NHB ● Wide type Air Hands WHDP<sup>Note2</sup>
- Flat type Air Hands ● RAG ● RAT ● DJ cylinders

Notes: 1. Only the horizontal lead wire type 2. Only the vertical lead wire type

Specifications

Item	Model	ZE135□	ZE155□	ZE235□	ZE255□
Wiring type		2-lead wire	3-lead wire	2-lead wire	3-lead wire
Lead wire direction		Horizontal		Vertical	
Power supply voltage		—	DC4.5~28V	—	DC4.5~28V
Load voltage		DC10~28V	DC4.5~28V	DC10~28V	DC4.5~28V
Load current		4~20mA at 25°C [77°F], and 10mA at 60°C [140°F]	50mA MAX.	4~20mA at 25°C [77°F], and 10mA at 60°C [140°F]	50mA MAX.
Consumption current		—	8mA MAX. (DC24V)	—	8mA MAX. (DC24V)
Internal voltage drop <sup>Note 1</sup>		4V MAX.	0.5V MAX. (10V or less at 20mA)	4V MAX.	0.5V MAX. (10V or less at 20mA)
Leakage current		0.7mA MAX. (DC24V, 25°C [77°F])	50µA MAX. (DC24V)	0.7mA MAX. (DC24V, 25°C [77°F])	50µA MAX. (DC24V)
Response time		1ms MAX.			
Insulation resistance		100MΩ MIN. (At DC500V Megger, between case and lead wire end)			
Dielectric strength		AC500V (50/60Hz) in 1 minute (Between case and lead wire end)			
Shock resistance <sup>Note 2</sup>		294.2m/s <sup>2</sup> [30G] (Non-repeated shock)			
Vibration resistance <sup>Note 2</sup>		88.3m/s <sup>2</sup> [9G] (Total amplitude 1.5mm [0.06in.], 10~55Hz)			
Environmental protection		IP67 (IEC standard), JIS C0920 (Water-proof type)			
Operation indicator		When ON: Red LED indicator lights up			
Lead wire <sup>Note 3</sup>		PCCV 0.2SQ X2-lead (Brown and blue) X ℓ	PCCV 0.15SQ X3-lead (Brown, blue, and black) X ℓ	PCCV 0.2SQ X2-lead (Brown and blue) X ℓ	PCCV 0.15SQ X3-lead (Brown, blue, and black) X ℓ
Ambient temperature		0~60°C [32~140°F]			
Storage temperature range		-10~70°C [14~158°F]			
Mass		15g [0.53oz.] (For lead wire length A: 1000mm), 35g [1.23oz.] (For lead wire length B: 3000mm)			

Notes: 1. The internal voltage drop depends on load current.  
 2. Measured by Koganei test standard.  
 3. Lead wire length ℓ : A; 1000mm [39in.], B; 3000m [118in.]

※ This product is not resistant to lightning surge of the EMC standard (EN61000-6-2 · EN60947-5-2).  
 Prepare protection measures for lightning surge in the system.

Internal Circuit

ZE135□, ZE235□

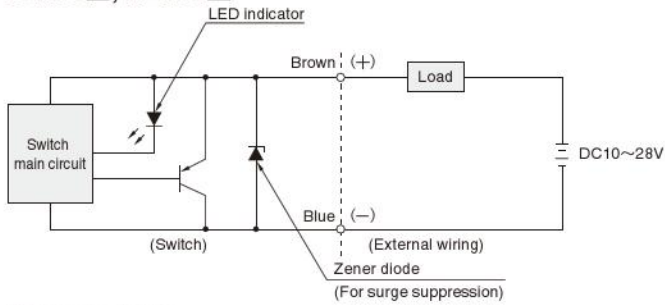

ZE155□, ZE255□

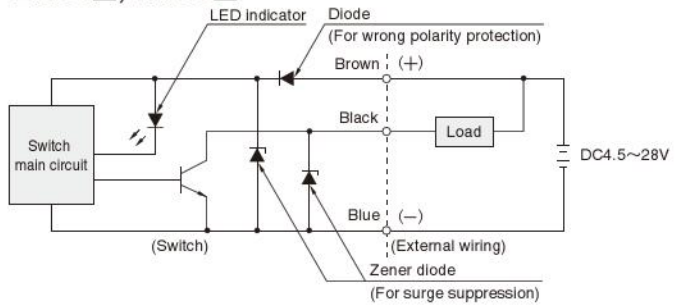

Dimensions (mm)

● Horizontal lead wire ZE135□, ZE155□

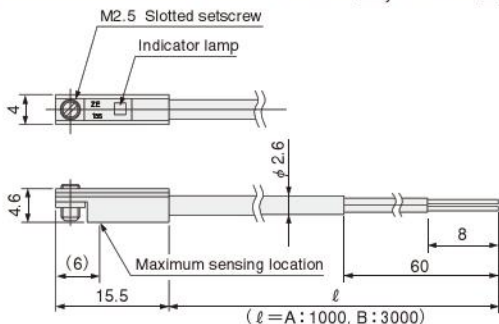

● Vertical lead wire ZE235□, ZE255□

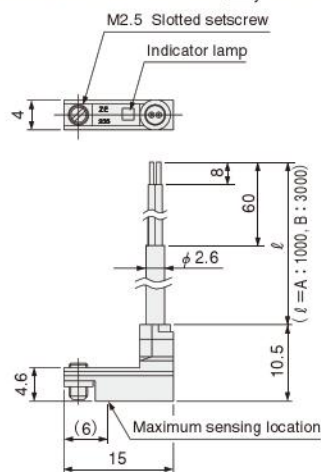

ZE175□, ZE275□



3-lead Wire PNP Output Type  
Solid State Sensor Switches

Applicable cylinders

●Mini bit cylinders ●Jig cylinders C series ●Jig cylinders JC series ●Mini guide sliders ●Jig cylinders with guides ●Twin rod cylinders B series ●Rod sliders ●Multi sliders ●Z sliders ●WS ●WT ●ACY<sup>Note 2</sup> ●ACZ<sup>Note 2</sup> ●Flat rodless cylinders<sup>Note 2</sup> ●ORV<sup>Note 2</sup> ●ORS, MRS<sup>Note 2</sup> ●ORW, MRW<sup>Note 2</sup> ●NHC1 series ●Air Hands NHB ●Wide type Air Hands WHDP<sup>Note 3</sup> ●Flat type Air Hands ●RAG ●RAT ●Three-finger Hands

Notes: 1. Because the same conductor as the robot cable is used, it exhibits superior bending resistance.  
2. Horizontal lead wire only  
3. Vertical lead wire only

Specifications

Item	Model	ZE175□	ZE275□
Wiring type		3-lead wire PNP output	
Lead wire direction		Horizontal	Vertical
Power supply voltage		DC4.5~28V	
Load voltage		DC4.5~28V	
Load current		50mA MAX.	
Consumption current		10mA MAX. (DC24V)	
Internal voltage drop <sup>Note 1</sup>		0.5V MAX. (10V or less at 20mA)	
Leakage current		50 μA MAX. (DC24V)	
Response time		1ms MAX.	
Insulation resistance		100MΩ MIN. (At DC500V Megger, between case and lead wire end)	
Dielectric strength		AC500V (50/60Hz) in 1 minute (Between case and lead wire end)	
Shock resistance <sup>Note 2</sup>		294.2m/s <sup>2</sup> [30G] (Non-repeated shock)	
Vibration resistance <sup>Note 2</sup>		88.3m/s <sup>2</sup> [9G] (Total amplitude 1.5mm [0.06in.], 10~55Hz)	
Environmental protection		IP67 (IEC standard), JIS C0920 (Water-proof type)	
Operation indicator		When ON: Red LED indicator lights up	
Lead wire <sup>Note 3</sup>		PCCV 0.15SQ×3-lead (Brown, blue, and black) ×ℓ	
Ambient temperature		0~60°C [32~140°F]	
Storage temperature range		-10~70°C [14~158°F]	
Mass		15g [0.53oz.] (For lead wire length A: 1000mm [39in.]), 35g [1.23oz.] (For lead wire length B: 3000mm [118in.]), 15g [0.53oz.] (For lead wire length G: 300mm [11.8in.] with M8 connector)	

Notes: 1. The internal voltage drop depends on load current.  
2. Measured by Koganei test standard.  
3. Lead wire length ℓ : A; 1000mm [39in.], B; 3000mm [118in.], G; 300mm [11.8in.] with M8 connector  
※ This product is not resistant to lightning surge of the EMC standard (EN61000-6-2 · EN60947-5-2).  
Prepare protection measures for lightning surge in the system.

Internal Circuit

ZE175□, ZE275□

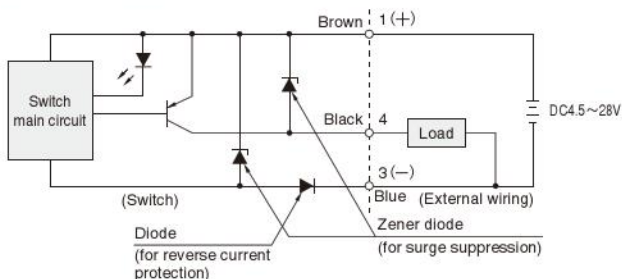

● Horizontal Lead Wire

**ZE175A**  
**ZE175B**

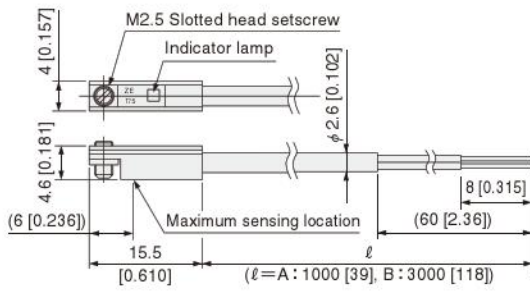

**ZE175G**

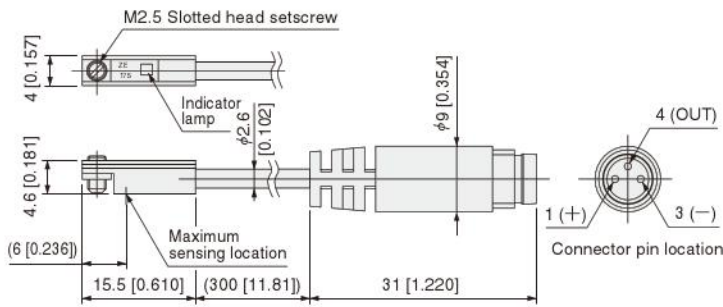

● Vertical Lead Wire

**ZE275A**  
**ZE275B**

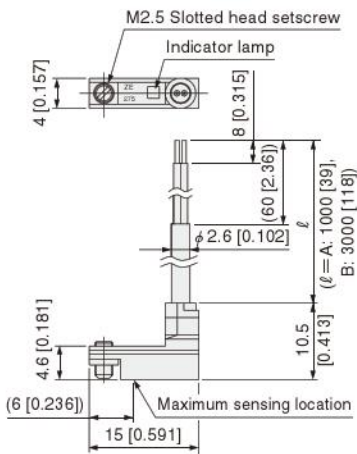

**ZE275G**

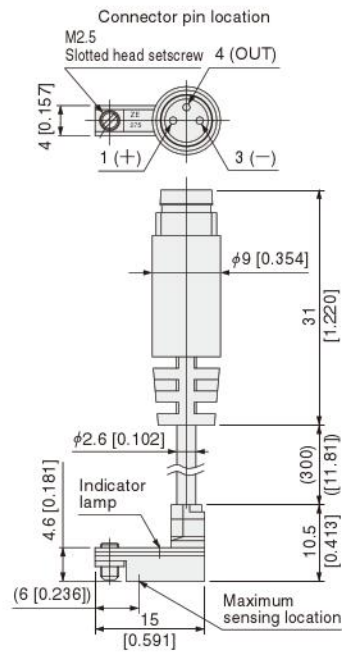

# CS9H□, ZB430□



## Solid State Type Sensor Switch

### Applicable cylinders

● Jig cylinders J series ● TDA  $\phi$  10[0.394in.]~  $\phi$  32[1.260in.] (previous type) ● Slide Units ● SHM

### Specifications

Item	Model	CS9H□	ZB430□
Wiring type		3-lead wire	2-lead wire
Power supply voltage		DC4.5~28V	DC10~28V
Load voltage		DC4.5~28V	DC10~28V
Load current		100mA MAX. (Ta=45°C [113°F])	4~50mA
Consumption current		15mA MAX. (DC24V)	—
Internal voltage drop <sup>Note 1</sup>		0.8V MAX. (At 50mA load current)	4.5V MAX.
Leakage current		50 $\mu$ A MAX. (DC24V)	1mA MAX. (DC24V at 25°C [77°F])
Response time		1ms MAX.	
Insulation resistance		100M $\Omega$ MIN. (At DC500V Megger, between case and lead wire end)	
Dielectric strength		AC500V (50/60Hz) in 1 minute (Between case and lead wire end)	
Shock resistance <sup>Note 2</sup>		294.2m/s <sup>2</sup> [30G] (Non-repeated shock)	
Vibration resistance <sup>Note 2</sup>		88.3m/s <sup>2</sup> [9G] (Total amplitude 1.5mm [0.06in.], 10~55Hz)	
Environmental protection		IP67 (IEC standard), JIS C0920 (Water-proof type)	
Operation indicator		When ON: Red LED indicator lights up	
Lead wire <sup>Note 3</sup>		PVC 0.2SQ X 3-lead X $\ell$	PVC 0.2SQ X 2-lead X $\ell$
Ambient temperature		0~60°C [32~140°F]	
Storage temperature range		-10~70°C [14~158°F]	
Mass (The mounting bracket is included.)		40g [1.41oz.] (For lead wire length A: 1000mm)	

Notes: 1. The internal voltage drop depends on load current.

2. Measured by Koganei test standard.

3. Lead wire length  $\ell$ : A; 1000mm [39in.], B; 3000mm [118in.]

※ This product is not resistant to lightning surge of the EMC standard (EN61000-6-2 · EN60947-5-2). Prepare protection measures for lightning surge in the system.

### Internal Circuit

#### CS9H□

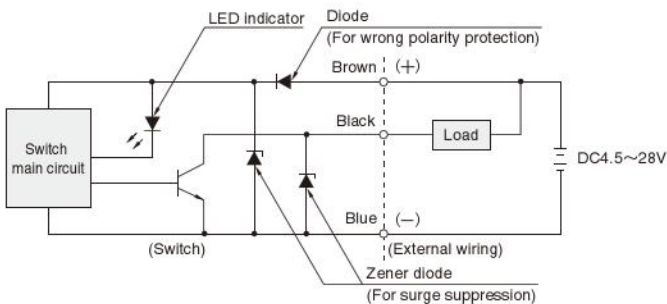

#### ZB430□

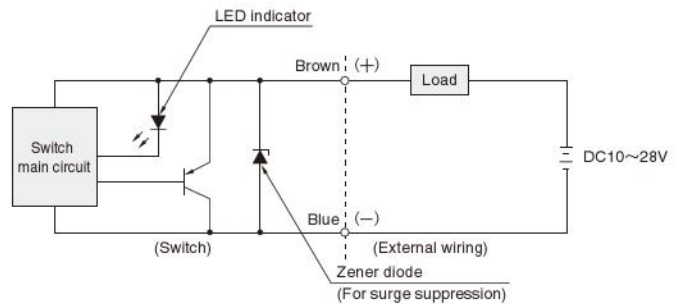

### Dimensions (mm)

#### CS9H□

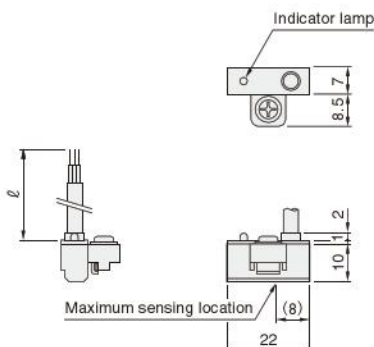

#### ZB430□

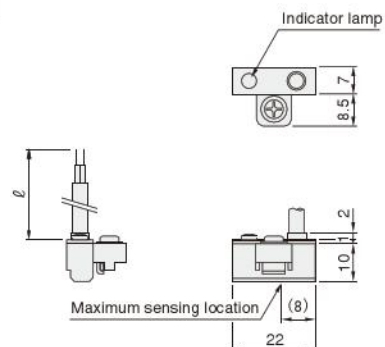

# Points of Wiring Solid State Type Sensor Switches

ZC130□, ZC230□, ZC330□  
 ZC630□, ZE135□, ZE235□  
 ZG530□, ZD136C, ZB430□

ZC153□, ZC253□, ZC353□, ZC653□  
 ZE155□, ZE255□, ZE175□, ZE275□, ZG553□, CS9H□

## ● 2-lead wire type

### ● Basic connection

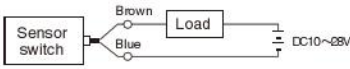

### ● Connecting with relays

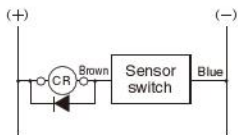

AND (series) connection and OR (parallel) connection

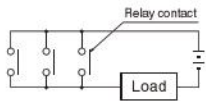
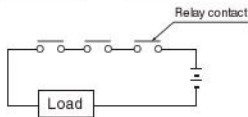
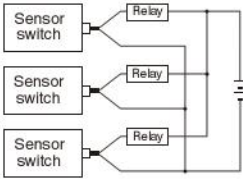

### ● Connecting with a solenoid valve

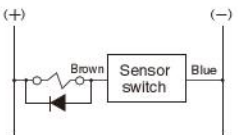

### ● Connecting with a programmable controller

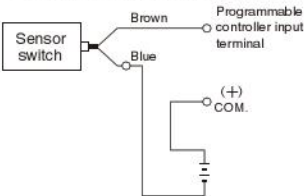

## ● 3-lead wire with NPN output

### ● Basic connection

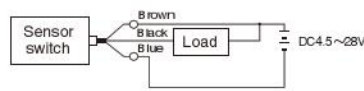

### ● Connecting with relays

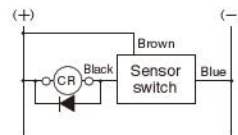

AND (series) connection and OR (parallel) connection

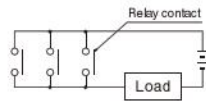
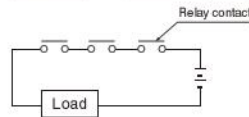
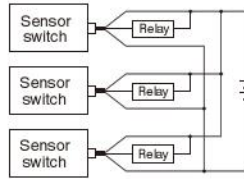

### ● Connecting with a solenoid valve

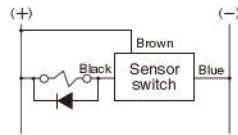

### ● Connecting with a programmable controller

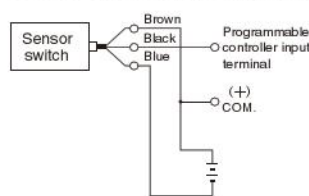

## ● 3-lead wire with PNP output

### ● Basic connection

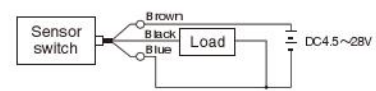

### ● Connecting with relays

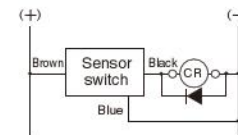

AND (series) connection and OR (parallel) connection

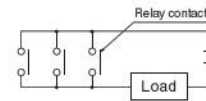
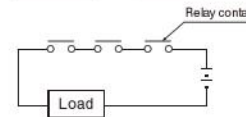
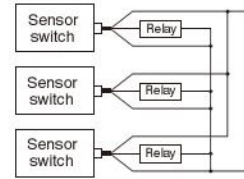

### ● Connecting with a solenoid valve

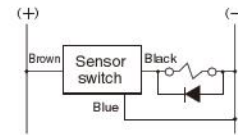

### ● Connecting with a programmable controller

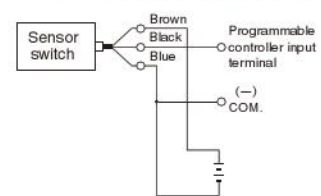

- Cautions:**
1. Connect the lead wires according to their color. Incorrect wiring will cause damage to the sensor switch since there is no overcurrent protection.
  2. With the inductive load of an electromagnetic relay, etc., the use of a surge protection diode is recommended.
  3. Avoid the use of AND (series) connections because the circuit voltage will drop in proportion to the number of sensor switches.
  4. When using an OR (parallel) connection, it is possible to connect sensor switch outputs directly (ex: using corresponding black lead wires). Be aware of load return errors since current leakage increases with the number of switches.

5. Because the sensor switches are magnetically sensitive, avoid using them in locations subject to strong external magnetic fields or bringing them in close proximity to power lines and areas where large electric currents are present. In addition, do not use magnetized materials for the mounting bracket, since this may cause erratic operation.
6. Do not excessively pull on or bend the lead wires.
7. Avoid using the sensor switches in environments where chemicals or gas are present.
8. Consult us for use in environments subject to water or oil.

# ZD136C

## Strong Magnetic Field Resistant Sensor Switch



### Applicable cylinders

- Jig cylinders JC series

### Specifications

Item	Model	ZD136C
Wiring type		2-lead wire
Load voltage		DC10~28V
Load current		5~50mA
Internal voltage drop		5.0V MAX. (At load current 50mA) <sup>Note 1</sup>
Leakage current		1.0mA MAX
Response time		50ms MAX. 80ms MAX.
	ON delay =	40ms TYP. OFF delay = 65ms TYP.
		30ms MIN. 50ms MIN.
Insulation resistance		100MΩ MIN. (At DC500V Megger, between case and lead wire end)
Dielectric strength		AC500V (50/60Hz) in 1 minute (Between case and lead wire end)
Shock resistance <sup>Note 2</sup>		294.2m/s <sup>2</sup> [30G] (Non-repeated shock)
Vibration resistance <sup>Note 2</sup>		88.3m/s <sup>2</sup> [9G] (Total amplitude 1.5mm [0.06in.], 10~55Hz)
Environmental protection		IP67 (IEC standard), JIS C0920 (water-proof type)
Operation indicator	Setting range	When ON: Green LED indicator lights up
	Unstable range	When ON: Red LED indicator lights up
Lead wire <sup>Note 3</sup>		Oil-resistant, spatter-resistant cabtyre cable 2-lead, 0.5SQX ℓ
Magnetic field resistance <sup>Note 2</sup>		AC17000A
Ambient temperature		0~60°C [32~140°F]
Storage temperature range		-10~70°C [14~158°F]
Mass		270g [9.52oz.]

Notes: 1. When using a programmable controller with input voltage of 12V, care should be taken about the programmable controller's ON voltage. The sensor switch's internal voltage drop could prevent use of the device.

2. Measured by Koganei test standard.

3. Lead wire length ℓ : C; 5000mm [197in.]

### Internal Circuit and Outline of Operations

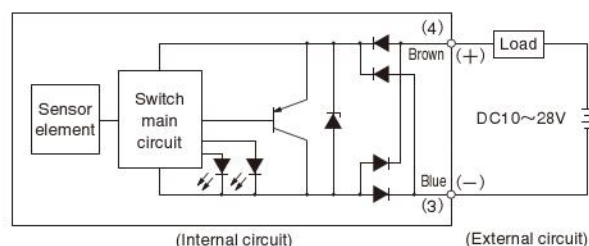

**Caution:** ZD136C is a non-polarity type. Connect either the brown or the blue lead wire to the load.

#### Outline of operations

Sensor switch	Magnetic field		Disturbance by an AC magnetic field	
	No disturbance by an AC magnetic field	Disturbance by an AC magnetic field	Without magnet	With magnet
Sensor element	OFF	ON	OFF ↔ ON	OFF ↔ ON
Sensor switch output	OFF	ON	OFF	ON

### Operation

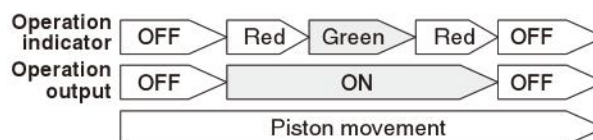

In an unstable range, the red LED lights up, while the green LED lights up when in the setting range.

Operation output is ON whenever an LED is lighted.

There is no change in operating output (sensor switch output) between the setting range and unstable range.

- The strong magnetic field resistant sensor switch can be used in locations subjected to disturbance by AC magnetic fields (areas near AC welders, etc.).

The strong magnetic field resistant sensor switch has a function of changing its output only when the magnetic field is applied for a fixed period of time in an ON or OFF state.

Magnetic fields generated by welding currents at areas near the AC welder change the current at set intervals, and the magnetic field is not continuously generated longer than the time required for changing the sensor switch output.

Therefore, the sensor switch output is not affected by magnetic fields generated by welding current from AC welders.

- Caution:** The sensor switch cannot be used in areas near DC welders (including inverters), because the magnetic fields generated by the DC welder remain constant.

- **In the case of no disturbance by an AC magnetic field**

When a sensor element detects the magnetic field of a magnet, the sensor switch output changes to ON about 40ms later. When the magnetic field generated by the magnet disappears, sensor switch output returns to the OFF position about 65ms later.

- **In the case of existing disturbance by an AC magnetic field**

Disturbance by an AC magnetic field causes sensor elements to switch repeatedly from ON to OFF states regardless of whether there is a magnet or not. However, use of an ON delay or OFF delay circuit allows sensor switch output to proceed without effect from disturbances by the AC magnetic field.

# Dimensions (mm)

## ● ZD136C

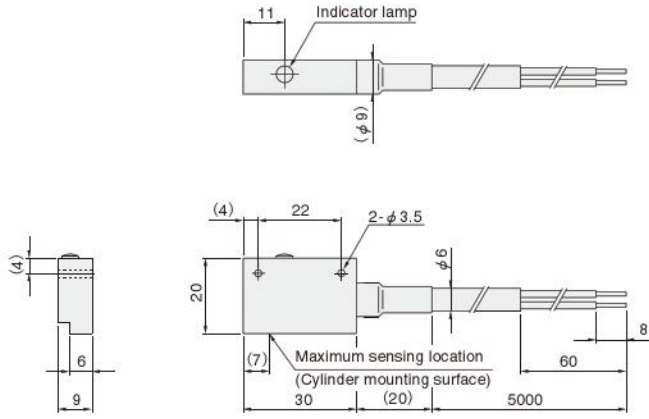

# CS5T□, CS11T□



## Reed Switch Type Sensor Switch

### Applicable cylinders

- Knock cylinders double acting type ● Multi mount cylinders ● DYNA cylinders ● SD cylinders ● TDA  $\phi$  6[0.236in.] ● AMT
- ARTB ● ACY (For the intermediate stopper) ● ORK  $\phi$  16[0.630in.] ● RAP ● RAN ● Swing cylinders

### Specifications

Item	Model	CS5T□	CS11T□
Wiring type		2-lead wire	
Load voltage		DC5~28V, AC85~115V (r.m.s.)	DC10~28V
Load current		DC0.1~40mA, AC2~25mA	DC5~40mA
Internal voltage drop <sup>Note 1</sup>		0.1V MAX. (At 40mA load current)	2.1V MAX. (At 40mA load current)
Leakage current		0mA	
Response time		1ms MAX.	
Insulation resistance		100M $\Omega$ MIN. (At DC500V Megger, between case and lead wire end)	
Dielectric strength		AC1500V (50/60Hz) in 1 minute (Between case and lead wire end)	AC1000V (50/60Hz) in 1 minute (Between case and lead wire end)
Shock resistance <sup>Note 2</sup>		294.2m/s <sup>2</sup> [30G] (Non-repeated shock)	
Vibration resistance <sup>Note 2</sup>		88.3m/s <sup>2</sup> [9G] (Total amplitude 1.5mm [0.06in.], 10~55Hz), Resonance frequency 2750 $\pm$ 250Hz	
Environmental protection		IP67 (IEC standard), JIS C0920 (Water-proof type)	
Operation indicator		—	When ON: Red LED indicator lights up
Lead wire <sup>Note 3</sup>		PVC 0.2SQ X 2-lead X $\ell$	
Ambient temperature		0~60°C [32~140°F]	
Storage temperature range		-10~70°C [14~158°F]	
Contact protection		Required (See contact protection on p.1566.)	
Mass		20g [0.71oz.] (For lead wire length A: 1000mm)	

- Notes: 1. The internal voltage drop depends on load current.  
 2. Measured by Koganei test standard.  
 3. Lead wire length  $\ell$  : A; 1000mm [39in.], B; 3000mm [118in.]

### Internal Circuit

CS5T□

CS11T□

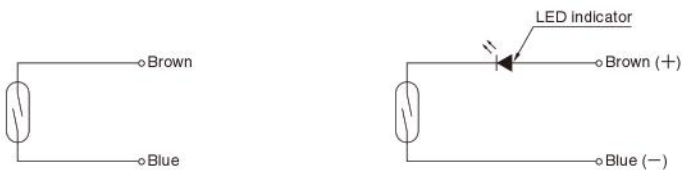

### Dimensions (mm)

CS5T□

CS11T□

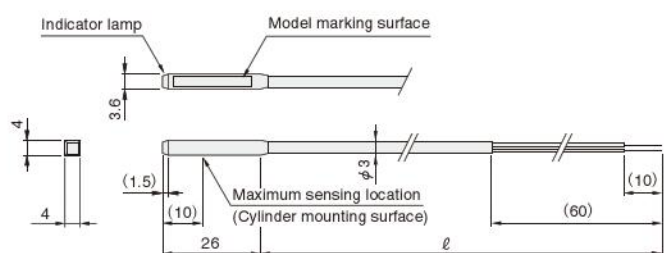
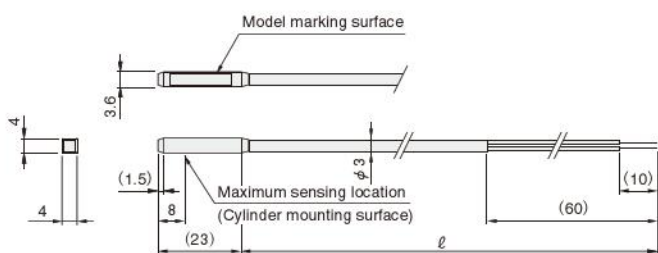

# ZC201 □, ZC205 □



## Reed Switch Type Sensor Switch

### Applicable cylinders

- Pen cylinders

### Specifications

Item	Model	ZC201 □	ZC205 □
Wiring type		2-lead wire	
Load voltage		DC5~28V, AC85~115V (r.m.s.)	DC10~28V
Load current		DC0.1~40mA, AC2~25mA	DC5~40mA
Internal voltage drop <sup>Note 1</sup>		0.1V MAX. (At 40mA load current)	2.1V MAX. (At 40mA load current) <sup>Note 1</sup>
Leakage current		0mA	
Response time		1ms MAX.	
Insulation resistance		100MΩ MIN. (At DC500V Megger, between case and lead wire end)	
Dielectric strength		AC1500V (50/60Hz) in 1 minute (Between case and lead wire end)	AC1000V (50/60Hz) in 1 minute (Between case and lead wire end)
Shock resistance <sup>Note 2</sup>		294.2m/s <sup>2</sup> [30G] (Non-repeated shock)	
Vibration resistance <sup>Note 2</sup>		88.3m/s <sup>2</sup> [9G] (Total amplitude 1.5mm [0.06in.], 10~55Hz), Resonance frequency 2750±250Hz	
Environmental protection		IP67 (IEC standard), JIS C0920 (Water-proof type)	
Operation indicator		—	When ON: Red LED indicator lights up
Lead wire <sup>Note 3</sup>		PCCV 0.2SQ X 2-lead X ℓ	
Ambient temperature		0~60°C [32~140°F]	
Storage temperature range		-10~70°C [14~158°F]	
Contact protection		Required (See contact protection on p.1566.)	
Mass		20g [0.71oz.] (For lead wire length A: 1000mm)	

- Notes: 1. The internal voltage drop depends on load current.  
 2. Measured by Koganei test standard.  
 3. Lead wire length ℓ : A; 1000mm [39in.], B; 3000mm [118in.]

### Internal Circuit

ZC201 □

ZC205 □

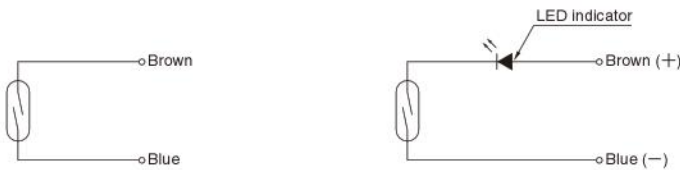

### Dimensions (mm)

ZC201 □

ZC205 □

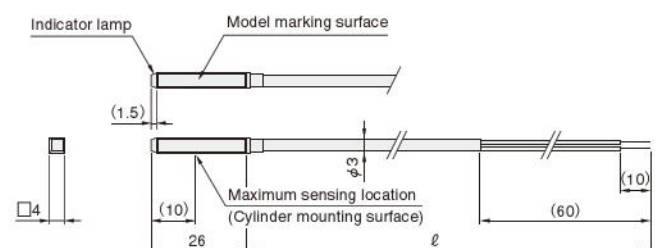
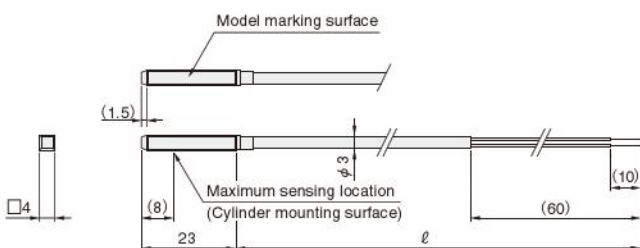

# CS3M□, 4M□, 5M□

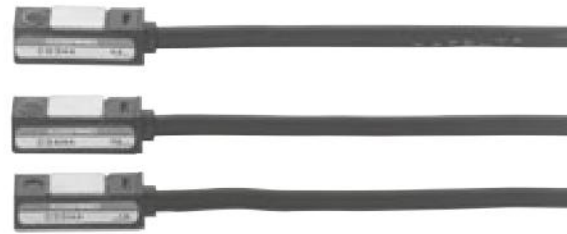

## Reed Switch Type Sensor Switch

### Applicable cylinders

- Slim cylinders ● Twinport cylinders ● GA ● ORC ● ORCA ● ORGA ● ORK Note
- MRG ● RAK ● Swing cylinders ● Twist cylinders

Note: Excluding  $\phi 16$  [0.630in.].

### Specifications

Item	Model	CS3M□	CS4M□	CS5M□
Wiring type		2-lead wire		
Load voltage		DC10~30V	AC85~230V (r.m.s.)	DC10~30V
			AC85~115V (r.m.s.)	DC3~30V
				AC85~115V (r.m.s.)
Load current		10~50mA <sup>Note 1</sup>	10~50mA(AC85~115V) <sup>Note 1</sup> 5~15mA(AC115~230V) <sup>Note 1</sup>	5~25mA <sup>Note 1</sup>
				5~20mA <sup>Note 1</sup>
				0.1~60mA
				2~25mA
Internal voltage drop <sup>Note 2</sup>		2.5V MAX. (At 50mA load current)		2.2V MAX. (At 25mA load current)
Leakage current		0mA		
Response time		1ms MAX.		
Insulation resistance		100M $\Omega$ MIN. (At DC500V Megger, between case and lead wire end)		
Dielectric strength		AC2200V (50/60Hz) in 1 minute (Between case and lead wire end)	AC1500V (50/60Hz) in 1 minute (Between case and lead wire end)	
Shock resistance <sup>Note 3</sup>		294.2m/s <sup>2</sup> [30G] (Non-repeated shock)		
Vibration resistance <sup>Note 3</sup>		88.3m/s <sup>2</sup> [9G] (Total amplitude 1.5mm [0.06in.], 10~55Hz), Resonance frequency 5000 $\pm$ 400Hz		
Operation indicator		When ON: Red LED indicator lights up		—
Lead wire <sup>Note 4</sup>		PVC 0.2SQ $\times$ 2-lead $\times$ $\ell$		
Ambient temperature		0~60°C [32~140°F]		
Storage temperature range		-10~70°C [14~158°F]		
Contact protection		Required (See contact protection on p.1566.)		
Mass		20g [0.71oz.] (For lead wire length A: 1000mm)		

Notes: 1. Ta=37°C [98.6°F]

2. The internal voltage drop depends on load current.

3. Measured by Koganei test standard.

4. Lead wire length  $\ell$ : A; 1000mm [39in.], B; 3000mm [118in.]

### Internal Circuit

#### CS3M□

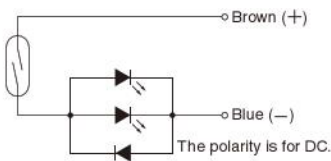

#### CS4M□

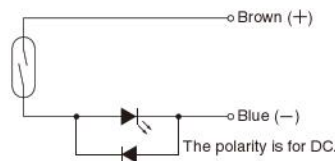

#### CS5M□

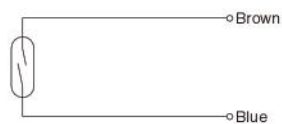

### Dimensions (mm)

#### CS3M□, CS4M□

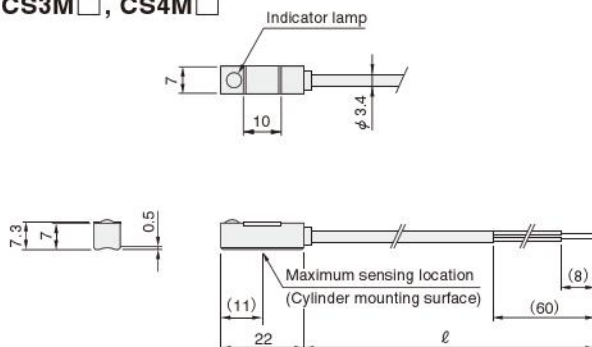

#### CS5M□

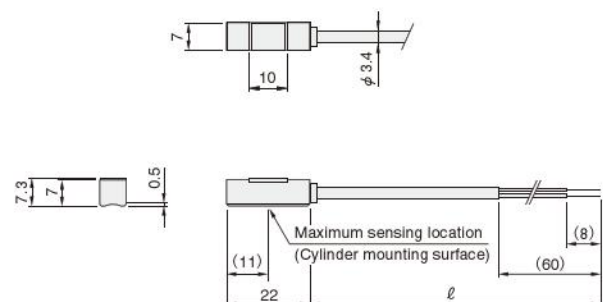

# CS3H□, 4H□, 5H□

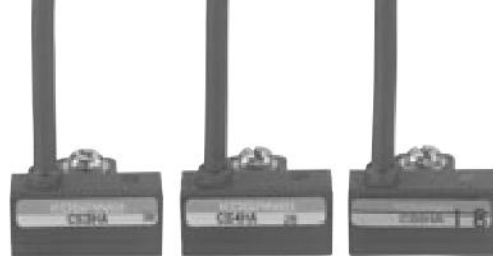

## Reed Switch Type Sensor Switch

### Applicable cylinders

● Jig cylinders J series ● TDA  $\phi$  10[0.394in.]~  $\phi$  32[1.260in.] (previous type) ● Slide Units

### Specifications

Item	Model	CS3H□	CS4H□	CS5H□	
Wiring type		2-lead wire			
Load voltage		DC10~30V	AC85~115V (r.m.s.)	DC10~30V	AC85~115V (r.m.s.)
Load current		10~50mA <sup>Note 1</sup>	10~50mA <sup>Note 1</sup>	5~25mA <sup>Note 1</sup>	5~20mA <sup>Note 1</sup>
Internal voltage drop <sup>Note 2</sup>		2.5V MAX. (At 50mA load current)		2.2V MAX. (At 25mA load current)	
Leakage current		0mA			
Response time		1ms MAX.			
Insulation resistance		100M $\Omega$ MIN. (At DC500V Megger, between case and lead wire end)			
Dielectric strength		AC1500V (50/60Hz) in 1 minute (Between case and lead wire end)			
Shock resistance <sup>Note 3</sup>		294.2m/s <sup>2</sup> [30G] (Non-repeated shock)			
Vibration resistance <sup>Note 3</sup>		88.3m/s <sup>2</sup> [9G] (Total amplitude 1.5mm [0.06in.], 10~55Hz)			
Environmental protection		—			
Operation indicator		When ON: Red LED indicator lights up		—	
Lead wire <sup>Note 3</sup>		PCCV 0.2SQ X 2-lead X $\ell$			
Ambient temperature		0~60°C [32~140°F]			
Storage temperature range		-10~70°C [14~158°F]			
Contact protection		Required (See contact protection on p.1566.)			
Mass		30g [1.06oz.] (For lead wire length A: 1000mm)			

Notes: 1. Ta=37°C [98.6°F]

2. The internal voltage drop depends on load current.

3. Measured by Koganei test standard.

4. Lead wire length  $\ell$ : A; 1000mm [39in.], B; 3000mm [118in.]

### Internal Circuit

#### CS3H□



#### CS4H□

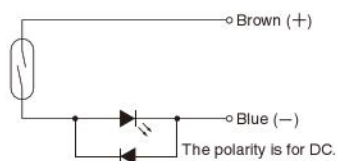

#### CS5H□



### Dimensions (mm)

#### CS3H□, CS4H□, CS5H□

Indicator lamp (CS5H□ is not included.)

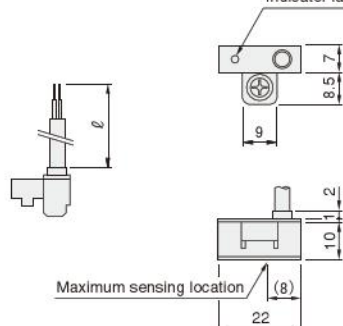

# ZC301 □, ZC305 □



## Reed Switch Type Sensor Switch

### Applicable cylinders

● AGTB ● AGTC ● ORCJ ● MRC

### Specifications

Item	Model	ZC301 □	ZC305 □
Wiring type		2-lead wire	
Load voltage		DC5~28V	AC85~115V (r.m.s.)
Load current		0.1~40mA	2~25mA
Internal voltage drop <sup>Note 1</sup>		0.1V MAX. (At 40mA load current)	
Leakage current		0mA	
Response time		1ms MAX.	
Insulation resistance		100MΩ MIN. (At DC500V Megger, between case and lead wire end)	
Dielectric strength		AC1500V (50/60Hz) in 1 minute (Between case and lead wire end)	AC1000V (50/60Hz) in 1 minute (Between case and lead wire end)
Shock resistance <sup>Note 2</sup>		294.2m/s <sup>2</sup> [30G] (Non-repeated shock)	
Vibration resistance <sup>Note 2</sup>		88.3m/s <sup>2</sup> [9G] (Total amplitude 1.5mm [0.06in.], 10~55Hz), Resonance frequency 2750±250Hz	
Environmental protection		IP67 (IEC standard), JIS C0920 (Water-proof type)	
Operation indicator		—	When ON: Red LED indicator lights up
Lead wire <sup>Note 3</sup>		PCCV 0.2SQ X 2-lead X ℓ	
Ambient temperature		0~60°C [32~140°F]	
Storage temperature range		-10~70°C [14~158°F]	
Contact protection		Required (See contact protection on p.1566.)	
Mass		20g [0.71oz.] (For lead wire length A: 1000mm)	

Notes: 1. The internal voltage drop depends on load current.  
 2. Measured by Koganei test standard.  
 3. Lead wire length ℓ : A; 1000mm [39in.], B; 3000mm [118in.]

### Internal Circuit

#### ZC301 □

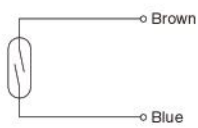

#### ZC305 □

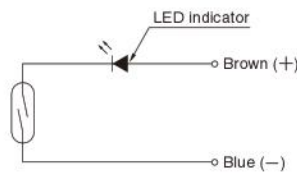

### Dimensions (mm)

#### ZC301 □

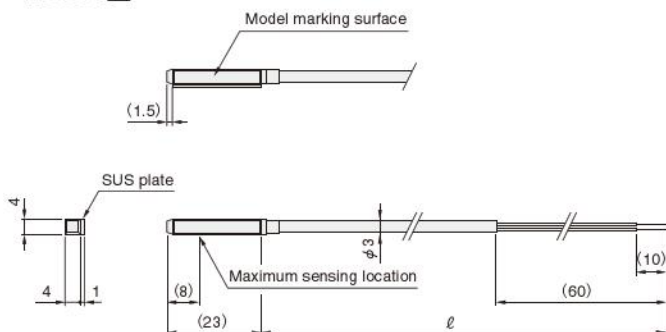

#### ZC305 □

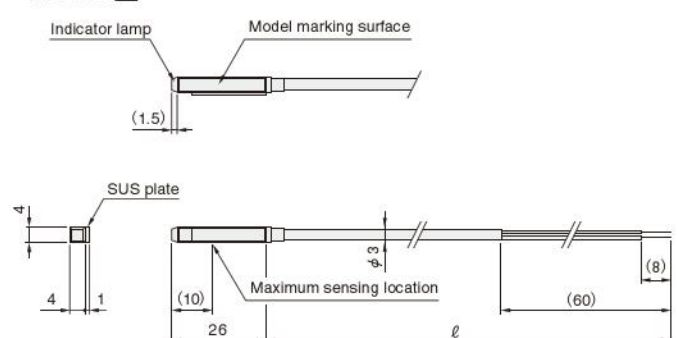

# ZC601 □, ZC605 □



## Reed Switch Type Sensor Switch

### Applicable cylinders

- Axis cylinders

### Specifications

Item	Model	ZC601 □	ZC605 □
Wiring type		2-lead wire	
Load voltage		DC5~28V	AC85~115V (r.m.s.)
Load current		DC0.1~40mA	AC2~25mA
Internal voltage drop <sup>Note 1</sup>		0.1V MAX. (At 40mA load current)	
Leakage current		0mA	
Response time		1ms MAX.	
Insulation resistance		100MΩ MIN. (At DC500V Megger, between case and lead wire end)	
Dielectric strength		AC1500V (50/60Hz) in 1 minute (Between case and lead wire end)	AC1000V (50/60Hz) in 1 minute (Between case and lead wire end)
Shock resistance <sup>Note 2</sup>		294.2m/s <sup>2</sup> [30G] (Non-repeated shock)	
Vibration resistance <sup>Note 2</sup>		88.3m/s <sup>2</sup> [9G] (Total amplitude 1.5mm [0.06in.], 10~55Hz), Resonance frequency 2750±250Hz	
Environmental protection		IP67 (IEC standard), JIS C0920 (Water-proof type)	
Operation indicator		—	When ON: Red LED indicator lights up
Lead wire <sup>Note 3</sup>		PCCV 0.2SQ X 2-lead X ℓ	
Ambient temperature		0~60°C [32~140°F]	
Storage temperature range		-10~70°C [14~158°F]	
Contact protection		Required (See contact protection on p.1566.)	
Mass		20g [0.71oz.] (For lead wire length A: 1000mm)	

- Notes: 1. The internal voltage drop depends on load current.  
 2. Measured by Koganei test standard.  
 3. Lead wire length ℓ : A; 1000mm [39in.], B; 3000mm [118in.]

### Internal Circuit

#### ZC601 □

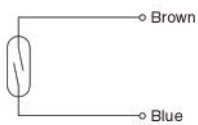

#### ZC605 □

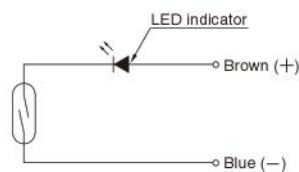

### Dimensions (mm)

#### ZC601 □

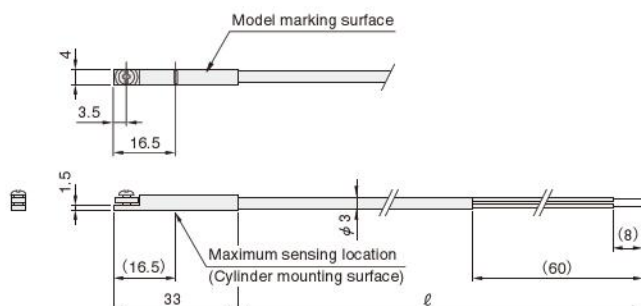

#### ZC605 □

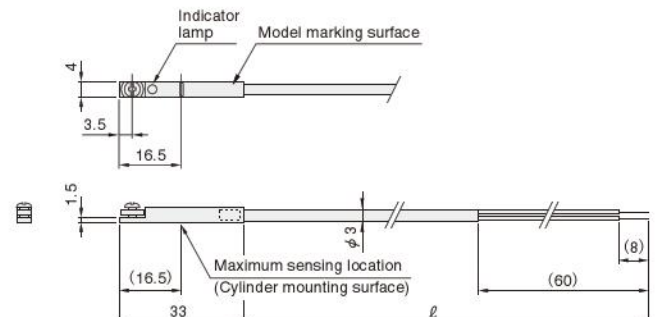

ZE101□, 102□, 201□, 202□



Reed Switch Type Sensor Switch



Applicable cylinders

- Jig cylinders C series ● Jig cylinders JC series ● Mini guide sliders ● Jig cylinders with guides ● Twin rod cylinders B series ● Rod sliders ● Multi sliders ● WT ● ACY<sup>Note</sup> ● ACZ<sup>Note</sup> ● WS ● Flat rodless cylinders ● ORV<sup>Note</sup> ● ORS<sup>Note</sup> ● MRS<sup>Note</sup> ● ORW, MRW ● RAG ● RAT ● DJ cylinders

Note: Only the horizontal lead wire type is available.

Specifications

Item	Model	ZE101□	ZE102□	ZE201□	ZE202□
Wiring type		2-lead wire			
Lead wire direction		Horizontal		Vertical	
Load voltage		DC5~28V, AC85~115V	DC10~28V, AC85~115V	DC5~28V, AC85~115V	DC10~28V, AC85~115V
Load current		DC40mA MAX., AC20mA MAX.	DC5~40mA, AC5~20mA	DC40mA MAX., AC20mA MAX.	DC5~40mA, AC5~20mA
Internal voltage drop <sup>Note 1</sup>		0.1V MAX. (At DC40mA load current)	3.0V MAX.	0.1V MAX. (At DC40mA load current)	3.0V MAX.
Leakage current		0mA			
Response time		1ms MAX.			
Insulation resistance		100MΩ MIN. (At DC500V Megger, between case and lead wire end)			
Dielectric strength		AC1500V (50/60Hz) in 1 minute (Between case and lead wire end)			
Shock resistance <sup>Note 2</sup>		294m/s <sup>2</sup> [30G] (Non-repeated shock)			
Vibration resistance <sup>Note 2</sup>		88.3m/s <sup>2</sup> [9G] (Total amplitude 1.5mm [0.06in.], 10~55Hz, Resonance frequency 2750±250Hz)			
Environmental protection		IP67 (IEC standard), JIS C0920 (Water-proof type)			
Operation indicator		None	When ON: Red LED indicator lights up	None	When ON: Red LED indicator lights up
Lead wire <sup>Note 3</sup>		PCCV 0.2SQX2-lead (Brown and blue)Xℓ			
Ambient temperature		0~60°C [32~140°F]			
Storage temperature range		-10~70°C [14~158°F]			
Contact protection		Required (See contact protection on p.1566.)			
Mass		15g [0.53oz.] (For lead wire length A: 1000mm), 35g [1.23oz.] (For lead wire length B: 3000mm)			

- Notes: 1. The internal voltage drop depends on load current.  
 2. Measured by Koganei test standard.  
 3. Lead wire length ℓ : A; 1000mm [39in.], B; 3000mm [118in.]

Internal Circuit

ZE101□, ZE201□

ZE102□, ZE202□

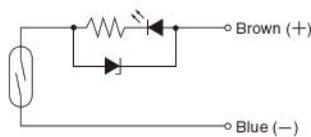

Dimensions (mm)

● Horizontal lead wire ZE101□, ZE102□

● Vertical lead wire ZE201□, ZE202□

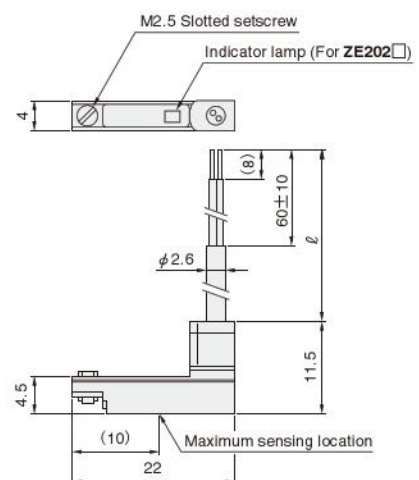
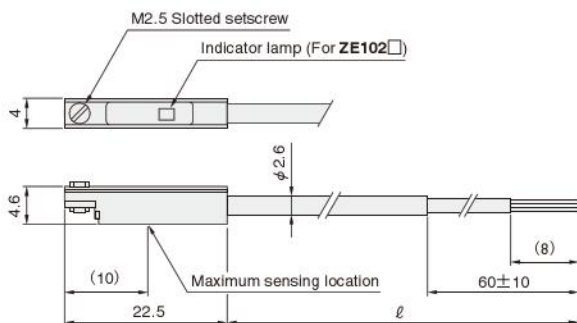

# CS2F, 3F, 4F, 5F

## Reed Switch Type Sensor Switch

### Applicable cylinders

● Slim cylinders <sup>Note</sup> ● DYNA cylinders ● GA ● Swing cylinders

Note: Excluding Slim block cylinder  $\phi$  16 [0.630in.]



### Specifications

Item	Model	CS2F	CS3F	CS4F	CS5F
Wiring type		2-lead wire			
Load voltage		AC85~230V (r.m.s)	DC5~30V	DC5~30V	DC3~30V
Load current		2~200mA	10~46mA <sup>Note 1</sup>	5~25mA <sup>Note 1</sup>	0.1~80mA
Internal voltage drop		0.1V MAX. (At 200mA load current)	3V MAX. (At 46mA load current) <sup>Note 2</sup>	2.8V MAX. (At 25mA load current) <sup>Note 2</sup>	0.1V MAX. (At 80mA load current)
Leakage current		1mA MAX. (AC100V) 2mA MAX. (AC200V)	0mA		
Response time		2ms MAX.	1.2ms MAX.		
Insulation resistance		100M $\Omega$ MIN. (At DC500V Megger, between case and lead wire end)			
Dielectric strength		AC500V (50/60Hz) in 1 minute (Between case and lead wire end)			
Shock resistance <sup>Note 3</sup>		294.2m/s <sup>2</sup> [30G] (Non-repeated shock)			
Vibration resistance <sup>Note 3</sup>		88.3m/s <sup>2</sup> [9G] (Total amplitude 1.5mm [0.06in.], 10~55Hz), Resonance frequency 5000 $\pm$ 400Hz			
Environmental protection		-			
Operation indicator		When ON: Red neon lamp turns off	When ON: Red LED indicator lights up		-
Method of wiring		With DIN connector (Cable outer diameter $\phi$ 6.5 [0.256in.] MAX., Wire $\phi$ 1.25SQ MAX.)			
Ambient temperature		0~60°C [32~140°F]			
Storage temperature range		-10~70°C [14~158°F]			
Contact protection		Not required	Required (See contact protection on p.1566.)		
Mass		40g [1.41oz.]			

Notes: 1. Ta=37°C [98.6°F]

2. The internal voltage drop depends on load current.

3. Measured by Koganei test standard.

### Internal Circuit

#### CS2F

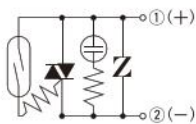

#### CS3F

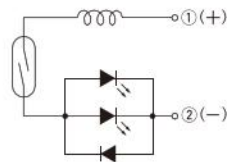

#### CS4F

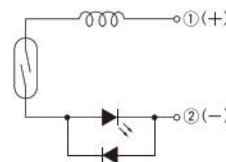

#### CS5F



The numbers in circle show the terminal numbers of the F type connector.

### Dimensions (mm)

#### CS2F, CS3F, CS4F

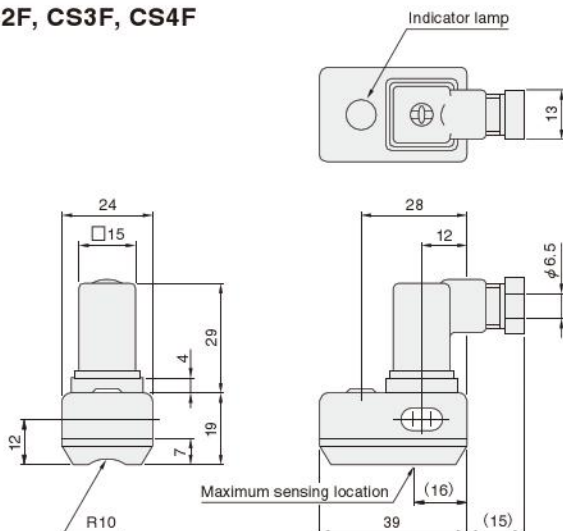

#### CS5F

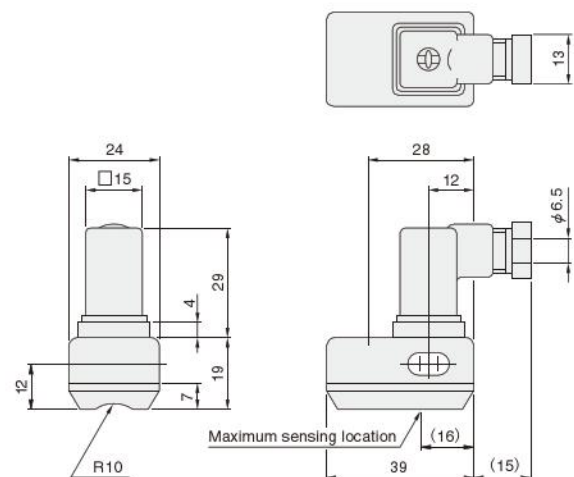

# CS2B, 3B, 4B, 5B

## Reed Switch Type Sensor Switch



### Specifications

Item	Model	CS2B	CS3B	CS4B	CS5B
Wiring type		2-lead wire			
Load voltage		AC85~230V (r.m.s)	DC5~30V	DC5~30V	DC3~30V
Load current		2~200mA	10~46mA <sup>Note 1</sup>	5~25mA <sup>Note 1</sup>	0.1~80mA
Internal voltage drop		0.1V MAX. (At 200mA load current)	3V MAX. (At 46mA load current) <sup>Note 2</sup>	2.8V MAX. (At 25mA load current) <sup>Note 2</sup>	0.1V MAX. (At 80mA load current)
Leakage current		1mA MAX. (AC100V) 2mA MAX. (AC200V)	0mA		
Response time		2ms MAX.	1.2ms MAX.		
Insulation resistance		100MΩ MIN. (At DC500V Megger, between case and lead wire end)			
Dielectric strength		AC500V (50/60Hz) in 1 minute (Between case and lead wire end)			
Shock resistance <sup>Note 3</sup>		294.2m/s <sup>2</sup> [30G] (Non-repeated shock)			
Vibration resistance <sup>Note 3</sup>		88.3m/s <sup>2</sup> [9G] (Total amplitude 1.5mm [0.06in.], 10~55Hz), Resonance frequency 2200±300Hz			
Environmental protection		—			
Operation indicator		When ON: Red neon lamp turns off	When ON: Red LED indicator lights up		—
Lead wire		VCT 0.3SQ X 2-lead X 1500mm [59in.]			
Ambient temperature		0~60°C [32~140°F]			
Storage temperature range		-10~70°C [14~158°F]			
Contact protection		Not required	Required (See contact protection on p.1566.)		
Mass		60g [2.12oz.]			

Notes: 1. Ta=37°C [98.6°F]

2. The internal voltage drop depends on load current.

3. Measured by Koganei test standard.

### Internal Circuit

#### CS2B

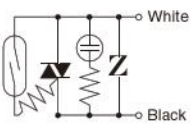

#### CS3B

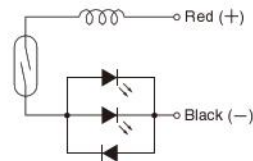

#### CS4B

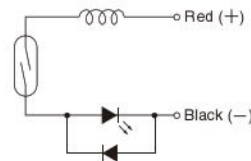

#### CS5B



### Dimensions (mm)

#### CS2B, CS3B, CS4B

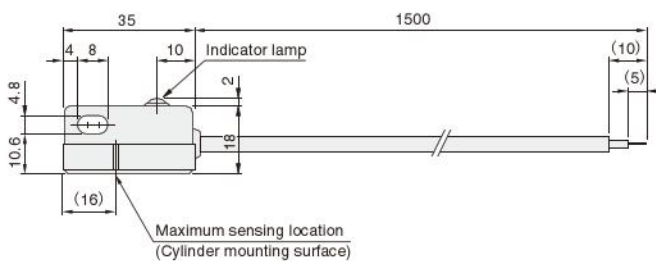

#### CS5B

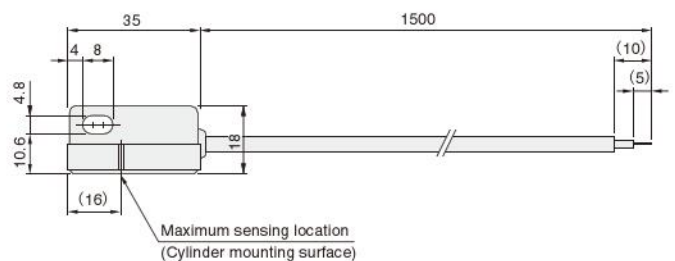

# Contact Protection for Reed Switch Type Sensor Switches

In order to use the reed switch type sensor switches in a stable condition, take the following contact protection measures.

## ● When you connect inductive load (electromagnetic relay, etc.).

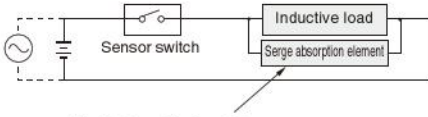

- For DC... Diode, CR, etc.
- For AC... CR, etc.
- Diode: Forward current should be more than the circuit current.  
Reverse voltage should be peak inverse voltage that is 10 times or more of the circuit voltage.
- CR: C=0.01~0.1μF  
R=1~4kΩ

## ● When capacity surge is generated.

(When lead wire length exceeds 10m.)

