

Koganei Clean System products provide complete support for the maintenance of a clean environment inside the cleanroom.

Koganei Clean System products meet the needs of the ultra-clean production environment. In everything from actuators and valves to air preparation and auxiliary equipment, anti-corrosion materials processing and other Koganei-developed design concepts serve to prevent particle contamination within the cleanroom. These perfectly designed mechanisms, which resolve even the slightest leaks to the outside during operations, have already won a high level of reliability.

Koganei Cleanliness

There is currently no standard in JIS or elsewhere for methods of evaluating cleanliness for pneumatic equipment in the cleanroom specifications. Therefore, to measure the effects of cleanroom contamination by pneumatic equipment, Koganei has decided to use “number of particles generated per 10 operations,” rather than particle density. Koganei has also developed classifications for application classes in cleanroom, based on JIS and other upper limit density tables, and on the company’s own experience.



- Remarks:
1. In the above table, product performance in terms of the number of particles generated per 10 operations is expressed as the upper limit of particles corresponding to the equivalent JIS or ISO class.
 2. In the above table, values in the JIS, ISO, and FED-STD upper limit density tables are calculated as upper density per liter.
 3. The classes shown are clean levels as classified in JIS and ISO.

From the above definitions, the Koganei clean level classes can be viewed as the level of average contamination per liter of surrounding air over a period of 10 operations in cleanroom. Air ventilation in cleanrooms is usually faster than 1 cycle per minute, and clean volumetric capacity is usually larger than 1 liter, which should provide a sufficient safety margin in practice.

Caution: The above conclusions are based on an ideal situation in which air ventilation is being implemented. For specific cases where air ventilation is not ensured, caution is needed since the clean classes cannot be maintained.

The clean system diagrams shown here are for Class 5 equivalent products. For Class 4 or Class 3 equivalent products, consult us.

Evaluations of Cleanliness

Koganei has therefore specified its in-house measurement methods, to conduct evaluations on the cleanroom rating.

The number of particles of the Air Cylinder Cleanroom Specification is measured as shown in the method below.

1. Measurement conditions

1-1 Test circuit: Figure 1 (no suction), Figure 2 (with suction)

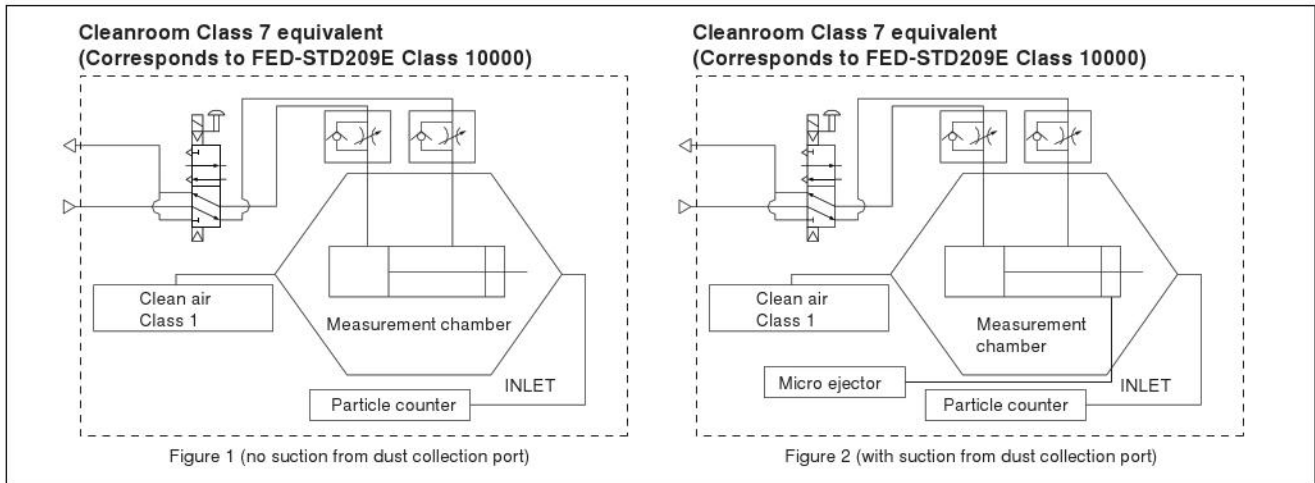

1-2 Operating conditions of tested cylinder

Operating frequency: 1Hz

Average speed: 500mm/s [20in./sec.]

Applied pressure: 0.5MPa [73psi.]

Suction condition: Microejector ME05, Primary side: 0.5MPa [73psi.] applied, Tube: $\phi 6$ [0.236in.]

Mounting direction: Vertical

Chamber volume: 8.3 ℓ [0.293ft³]

2. Particle counter

Manufacturer/model: RION/KM20

Suction flow rate: 28.3 ℓ /min [1ft³/min.]

Particle diameter: 0.1 μm , 0.2 μm , 0.3 μm , 0.5 μm , 0.7 μm , 1.0 μm

3. Measurement method

3-1 Confirmation of number of particles in the measurement system

Under the conditions in the above 1 and 2, using a particle counter to measure the sample for 9 minutes without operating the measurement sample, and confirmed the measured number of particle is 1 piece or less.

3-2 Measurement under operation

Under the conditions in the above 1 and 2, operating the measurement sample for 36 minutes, and measured the total values in the latter half of 18 minutes test.

3-3 Reconfirmation

Performed the measurement in 3-1 again, to reconfirm the number of particles in the measurement system.

4. Measurement results

● Cleanroom specification

Jig Cylinder (no suction from dust collection port)

Particle generation over 1 million operations (CS-CDA16 \times 30)

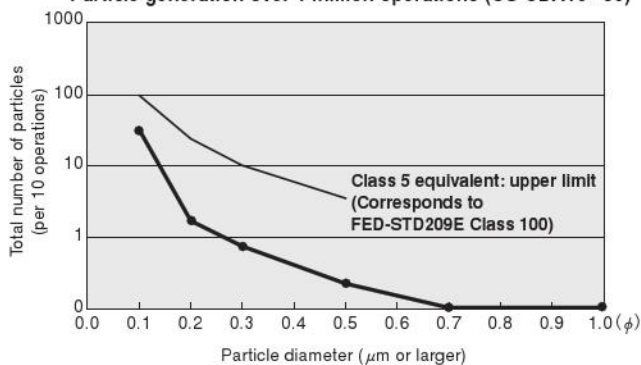

● Cleanroom specification

Slim Cylinder (with suction from dust collection port)

Particle generation over 1 million operations (CS-DA20 \times 100)

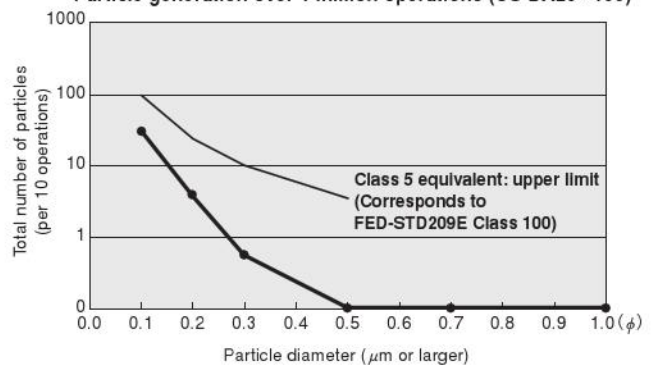

For "safety precautions" listed in the Clean System Product Drawings, see the materials below.

- For actuators, see "Safety Precautions" on p. 45 of the Actuators General Catalog .
- For valves, see "Safety Precautions" on p. 31 of the Valves General Catalog.
- For air treatment and auxiliary equipment, see "Safety Precautions" on p.31 of the General Catalog of Air Treatment, Auxiliary, Vacuum.

Symbol

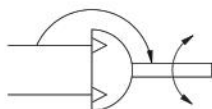

Specifications

Model		CS-RAP□1	CS-RAP□5	CS-RAP□10	CS-RAP□20
Item					
Operating type		Double acting piston type (Rack and pinion construction)			
Effective torque ^{Note}	N·m [ft·lbf]	0.078 [0.058]	0.373 [0.275]	0.883 [0.651]	1.863 [1.374]
Swing angle (Tolerance $\pm 1^\circ$)	CS-RAP□-90	90°			
	CS-RAP□-100	100°			
	CS-RAP□-180	180°			
	CS-RAP□-190	190°			
	CS-RAP□-360	360°			
Media		Air			
Port size		M5×0.8	Rc1/8		
Rod diameter	mm [in.]	4 [0.157]	6 [0.236]	8 [0.315]	10 [0.394]
Operating pressure range	MPa [psi.]	0.15~0.7 [22~102]		0.06~0.7 [9~102]	
Proof pressure	MPa [psi.]	1.03 [149]			
Operating temperature range	°C [°F]	0~50 [32~122]			
Allowable energy	J [in·lbf]	0.001 [0.009]	0.003 [0.027]	0.008 [0.071]	0.015 [0.133]
Lubrication		Not required			
Cushion		None			

Note: Values are obtained when the air pressure is 0.49MPa [71psi].

Mass

Model	Main body mass	Additional mass	
		Double rod specification	With sensor switch specification ^{Note}
CS-RAP1-90,100	101 [3.56]	2 [0.07]	With 1 sensor switch: 24 [0.85] With 2 sensor switches: 46 [1.62]
CS-RAP1-180,190	119 [4.20]		
CS-RAP1-360	166 [5.86]		
CS-RAP5-90,100	252 [8.89]	4 [0.14]	
CS-RAP5-180,190	300 [10.58]		
CS-RAP5-360	415 [14.64]		
CS-RAP10-90,100	346 [12.20]	10 [0.35]	
CS-RAP10-180,190	426 [15.03]		
CS-RAP10-360	584 [20.60]		
CS-RAP20-90,100	561 [19.79]	16 [0.56]	
CS-RAP20-180,190	675 [23.81]		
CS-RAP20-360	931 [32.84]		

Calculation example: Mass of CS-RAP1-180 with double rod and 1 sensor switch;
 $119 + 2 + 24 = 145\text{g}$ [5.11oz.]

Note: The additional mass of the sensor switch is the mass of the sensor holder and the sensor body only, and does not include the lead wire mass.

Order Codes

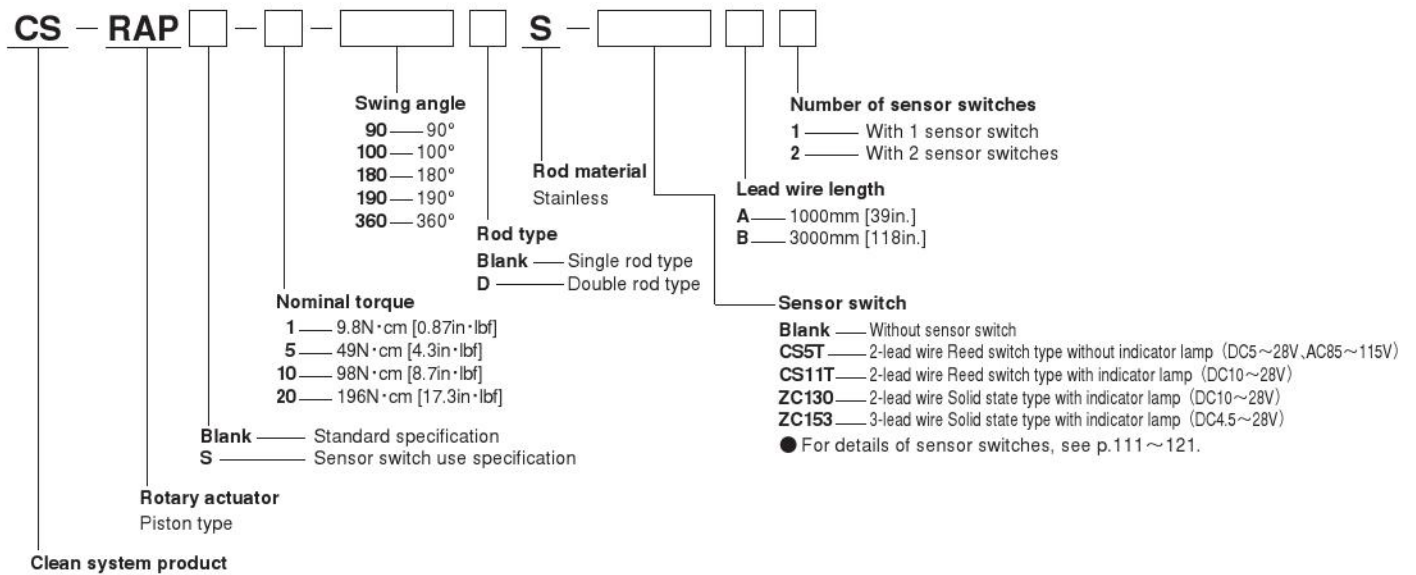

Inner Construction and Major Parts

● Sensor switch use specification

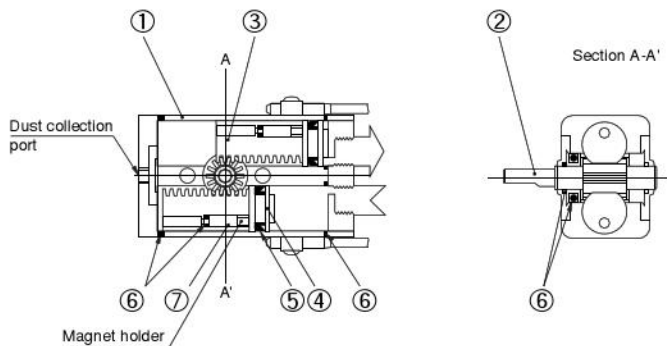

Major Parts and Materials

No.	Parts	Materials
①	Main body	Aluminum (anodized)
②	Rod pinion	Stainless steel (SUS304)
③	Rack	Plastic
④	Piston	
⑤	Piston seal	Synthetic rubber (NBR)
⑥	O-ring	
⑦	Magnet	Plastic magnet

Seals

Model	Item	O-ring			Piston seal
	Q'ty	4	2	2	2
CS-RAP□1	IN 10		I.D φ 6 × φ 1.2	I.D φ 9 × φ 1.5	PPY-10
CS-RAP□5	IN 16		I.D φ 9 × φ 1.5	I.D φ 14 × φ 1.5	PPY-16
CS-RAP□10	IN 20		P8	I.D φ 19 × φ 0.6	PPY-20
CS-RAP□20	I.D φ 25 × φ 1.5		P10	I.D φ 24.6 × φ 0.7	PPY-25

CS-RAP□1

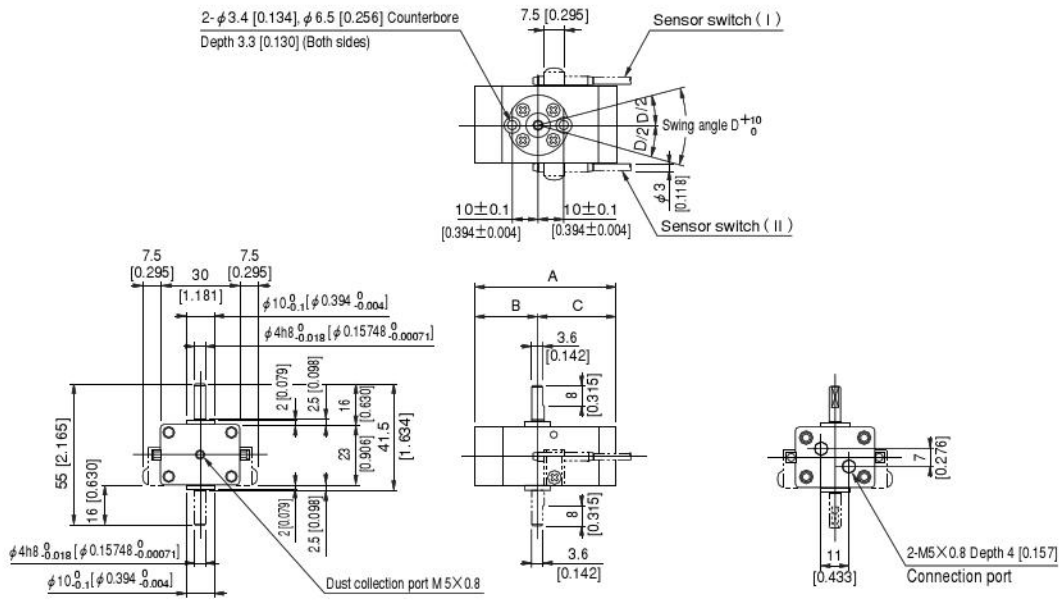

Code	A	B	C	D
Model				
RAP□1-90	56 [2.205]	25 [0.984]	31 [1.220]	90°
RAP□1-100				100°
RAP□1-180	68 [2.677]	31 [1.220]	37 [1.457]	180°
RAP□1-190				190°
RAP□1-360	96 [3.780]	45 [1.772]	51 [2.008]	360°

CS-RAP□5

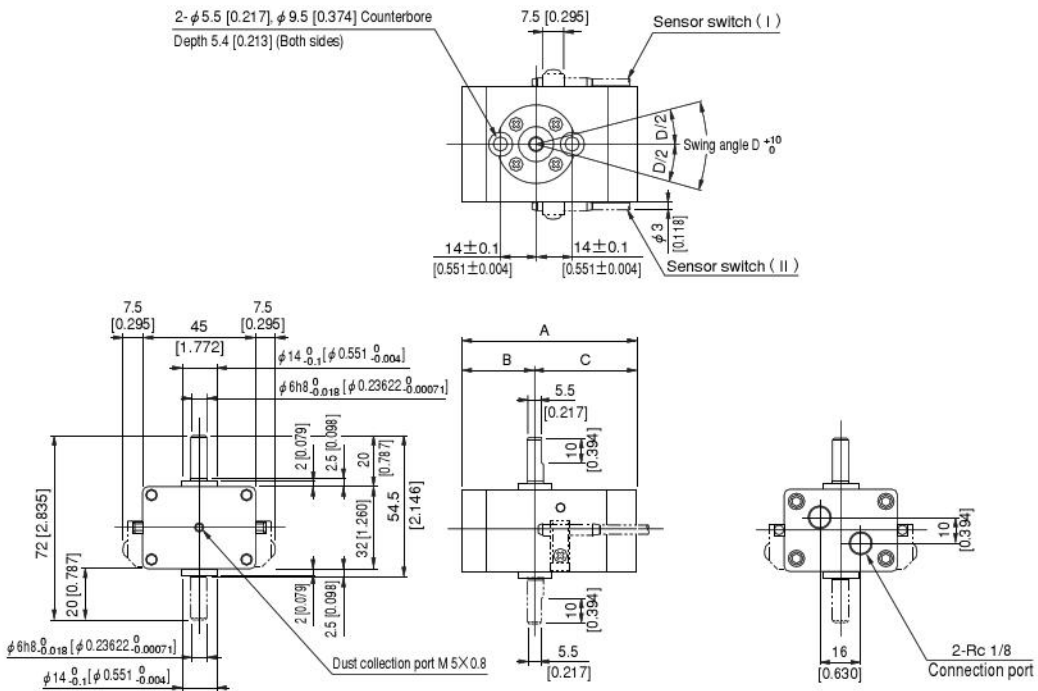

Code	A	B	C	D
Model				
RAP□5-90	70 [2.756]	30.5 [1.201]	39.5 [1.555]	90°
RAP□5-100				100°
RAP□5-180	86 [3.386]	35.5 [1.398]	50.5 [1.988]	180°
RAP□5-190				190°
RAP□5-360	124 [4.882]	55 [2.165]	69 [2.717]	360°

CS-RAP □ 10

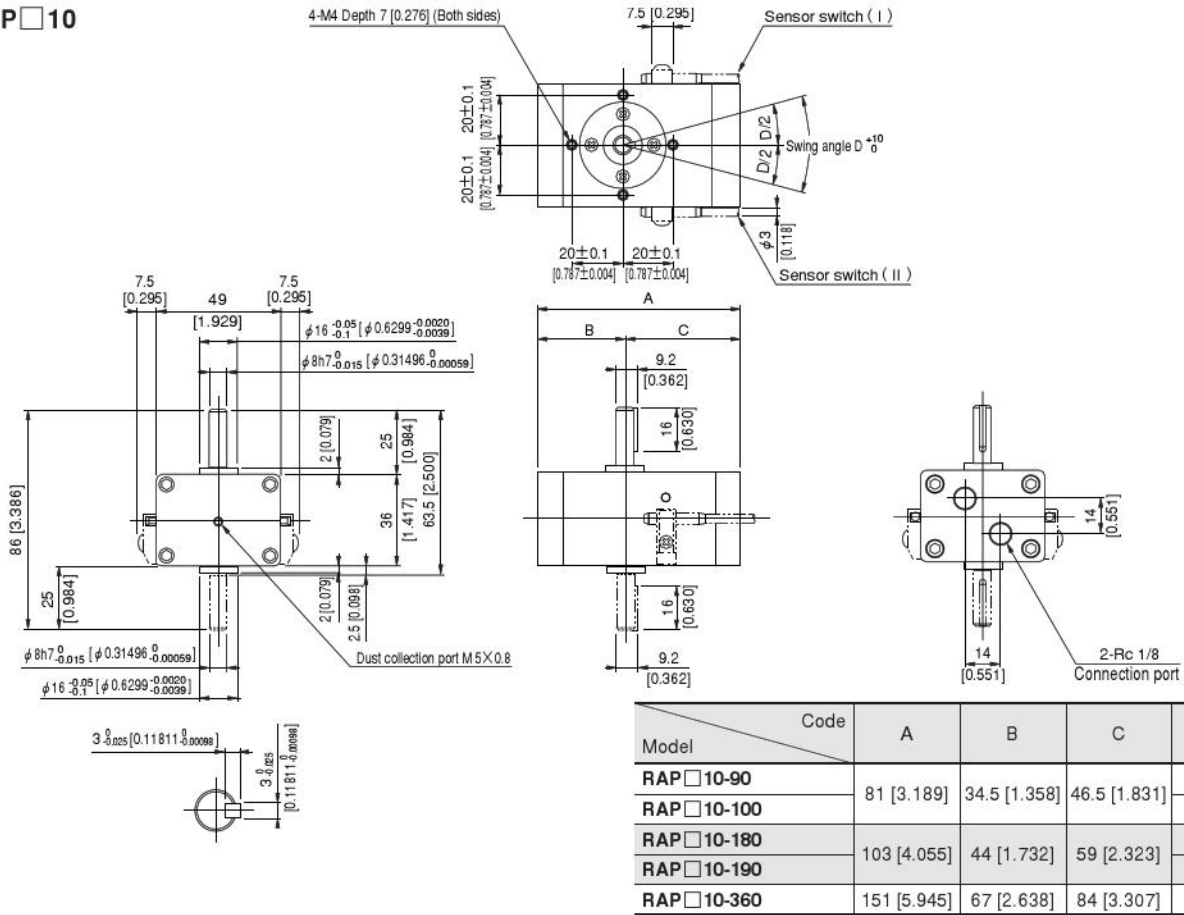

CS-RAP □ 20

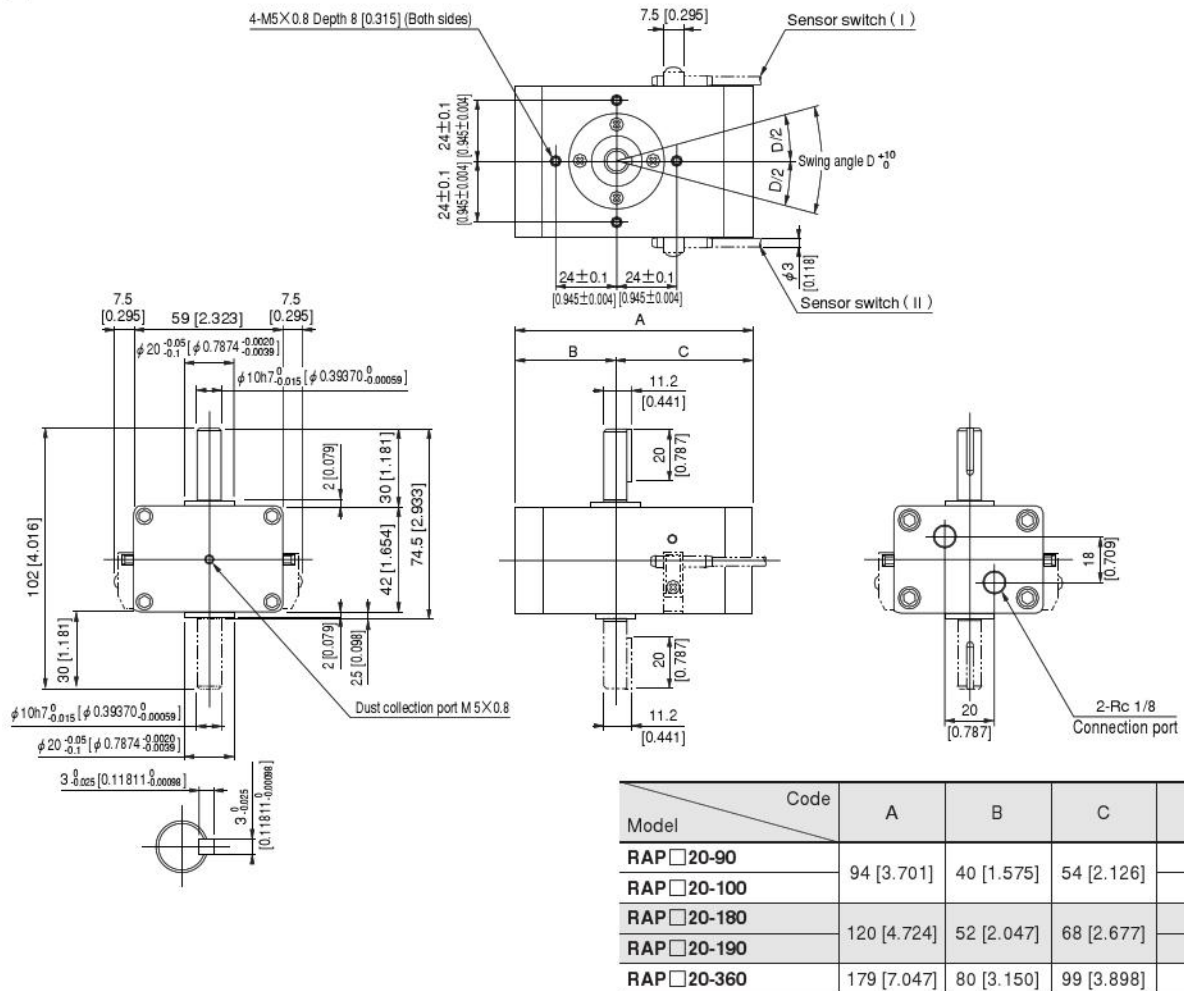

ROTARY ACTUATORS RAP SERIES

Sensor Switches

Order Codes

				Sensor switch model	Lead wire length	Holder / nominal torque		
Solid state type	2-lead wire	With indicator lamp	DC10~28V	CS-	ZC130	A B	-RAPS	1 5 10 20
Solid state type	3-lead wire	With indicator lamp	DC4.5~28V		ZC153			
Reed switch type	2-lead wire	Without indicator lamp	DC5~28V AC85~115V		CS5T			
Reed switch type	2-lead wire	With indicator lamp	DC10~28V		CS11T			

● For details of sensor switches, see p.111~121.

● Order code for holder only



● A : 1000mm [39in.]
● B : 3000mm [118in.]

● Blank : Without holder
-RAPS : With holder

● Blank : Without holder
1 : For RAPS1
5 : For RAPS5
10 : For RAPS10
20 : For RAPS20

Note: When ordering with holder, enter the nominal torque.

Swing End Detection and Mounting Location of Sensor Switch

When the sensor switch is mounted in the location shown in the diagram, the magnet comes to the maximum sensing location of the sensor switch at the end of the swing. At this time, the sensor switch A operates at the end of the swing in the A direction, and sensor switch B operates at the end of the swing in the B direction.

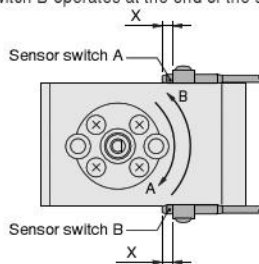

- Notes: 1. Do not mount the sensor switch in the reverse direction.
2. When an external stopper, etc., limits the swing angle, note that there may be cases where the sensor switch does not operate within the above adjusting range.

Model	X : Maximum sensing location mm [in.]		
	ZC130, ZC153	CS5T	CS11T
RAPS1	6.5 [0.256]	5.0 [0.197]	8.5 [0.335]
RAPS5	7.0 [0.276]	5.5 [0.217]	9.0 [0.354]
RAPS10	6.5 [0.256]	5.0 [0.197]	8.5 [0.335]
RAPS20			

Sensor Switch Operating Range and Response Differential

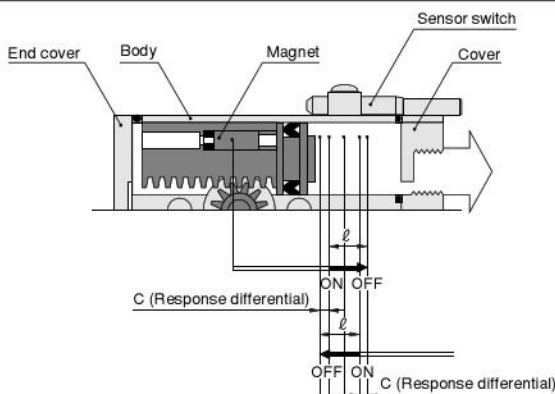

CS5T □		CS11T □		ZC1 □□□	
Operating range ℓ	Response differential C	Operating range ℓ	Response differential C	Operating range ℓ	Response differential C
4.7~10.8 [0.185~0.425]	1.4 [0.055] or less	6.8~9.5 [0.268~0.374]	1.4 [0.055] or less	1.5~4.7 [0.059~0.185]	0.3 [0.012] or less

Remark: The above table shows reference values.

Reference

- When use of an external stopper limits the swing angle, 2 sensor switches can be used up to the angle (α) shown below. The recommended type of the sensor switch is a solid state sensor switch for its short operating range.

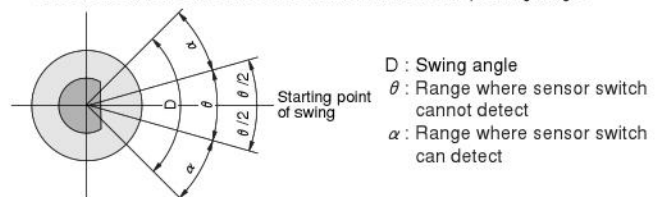

Model	Swing angle	θ Note	α
RAPS1	90°	56°	17°
	100°		22°
	180°		62°
	190°		67°
	360°		100°
RAPS5	90°	42°	24°
	100°		29°
	180°		69°
	190°		74°
	360°		170°
RAPS10	90°	32°	29°
	100°		34°
	180°		70°
	190°		75°
	360°		220°
RAPS20	90°	26°	32°
	100°		37°
	180°		50°
	190°		55°
	360°		250°

Note: Two sensor switches may be ON at the same time when the angle adjustment is set to this value or below.

Remark: For the use of reed type sensor switches, or for swing starting points other than those listed above, consult us.

● Caution when installing RAP with sensor switch

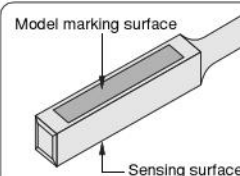

In the ZC type sensor switches, the opposite side from the model marking surface is the sensing surface side. Mount it so that the cylinder magnet comes to the sensing surface side.