

# Koganei Clean System products provide complete support for the maintenance of a clean environment inside the cleanroom.

Koganei Clean System products meet the needs of the ultra-clean production environment. In everything from actuators and valves to air preparation and auxiliary equipment, anti-corrosion materials processing and other Koganei-developed design concepts serve to prevent particle contamination within the cleanroom. These perfectly designed mechanisms, which resolve even the slightest leaks to the outside during operations, have already won a high level of reliability.

## Koganei Cleanliness

There is currently no standard in JIS or elsewhere for methods of evaluating cleanliness for pneumatic equipment in the cleanroom specifications. Therefore, to measure the effects of cleanroom contamination by pneumatic equipment, Koganei has decided to use “number of particles generated per 10 operations,” rather than particle density. Koganei has also developed classifications for application classes in cleanroom, based on JIS and other upper limit density tables, and on the company’s own experience.



- Remarks:
1. In the above table, product performance in terms of the number of particles generated per 10 operations is expressed as the upper limit of particles corresponding to the equivalent JIS or ISO class.
  2. In the above table, values in the JIS, ISO, and FED-STD upper limit density tables are calculated as upper density per liter.
  3. The classes shown are clean levels as classified in JIS and ISO.

From the above definitions, the Koganei clean level classes can be viewed as the level of average contamination per liter of surrounding air over a period of 10 operations in cleanroom. Air ventilation in cleanrooms is usually faster than 1 cycle per minute, and clean volumetric capacity is usually larger than 1 liter, which should provide a sufficient safety margin in practice.

Caution: The above conclusions are based on an ideal situation in which air ventilation is being implemented. For specific cases where air ventilation is not ensured, caution is needed since the clean classes cannot be maintained.

**The clean system diagrams shown here are for Class 5 equivalent products. For Class 4 or Class 3 equivalent products, consult us.**

# Evaluations of Cleanliness

Koganei has therefore specified its in-house measurement methods, to conduct evaluations on the cleanroom rating.

The number of particles of the Air Cylinder Cleanroom Specification is measured as shown in the method below.

## 1. Measurement conditions

1-1 Test circuit: Figure 1 (no suction), Figure 2 (with suction)

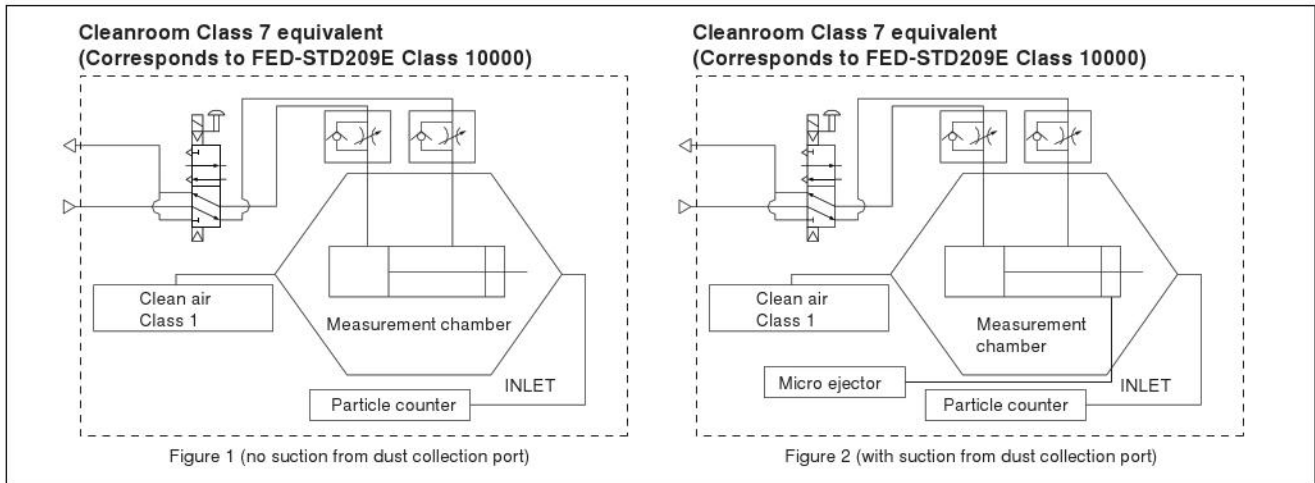

1-2 Operating conditions of tested cylinder

Operating frequency: 1Hz

Average speed: 500mm/s [20in./sec.]

Applied pressure: 0.5MPa [73psi.]

Suction condition: Microejector ME05, Primary side: 0.5MPa [73psi.] applied, Tube:  $\phi 6$  [0.236in.]

Mounting direction: Vertical

Chamber volume: 8.3  $\ell$  [0.293ft<sup>3</sup>]

## 2. Particle counter

Manufacturer/model: RION/KM20

Suction flow rate: 28.3  $\ell$  /min [1ft<sup>3</sup>/min.]

Particle diameter: 0.1  $\mu\text{m}$ , 0.2  $\mu\text{m}$ , 0.3  $\mu\text{m}$ , 0.5  $\mu\text{m}$ , 0.7  $\mu\text{m}$ , 1.0  $\mu\text{m}$

## 3. Measurement method

3-1 Confirmation of number of particles in the measurement system

Under the conditions in the above 1 and 2, using a particle counter to measure the sample for 9 minutes without operating the measurement sample, and confirmed the measured number of particle is 1 piece or less.

3-2 Measurement under operation

Under the conditions in the above 1 and 2, operating the measurement sample for 36 minutes, and measured the total values in the latter half of 18 minutes test.

3-3 Reconfirmation

Performed the measurement in 3-1 again, to reconfirm the number of particles in the measurement system.

## 4. Measurement results

### ● Cleanroom specification

Jig Cylinder (no suction from dust collection port)

Particle generation over 1 million operations (CS-CDA16 $\times$ 30)

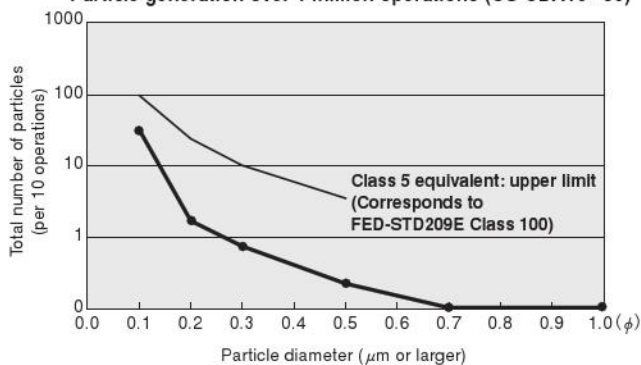

### ● Cleanroom specification

Slim Cylinder (with suction from dust collection port)

Particle generation over 1 million operations (CS-DA20 $\times$ 100)

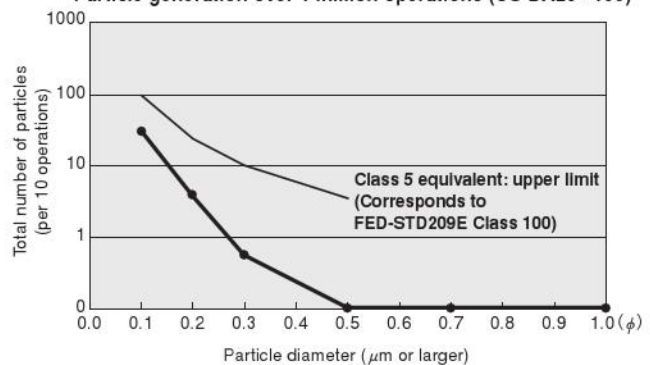

For "safety precautions" listed in the Clean System Product Drawings, see the materials below.

- For actuators, see "Safety Precautions" on p. 45 of the Actuators General Catalog .
- For valves, see "Safety Precautions" on p. 31 of the Valves General Catalog.
- For air treatment and auxiliary equipment, see "Safety Precautions" on p.31 of the General Catalog of Air Treatment, Auxiliary, Vacuum.

## Symbols

**3-port  
Normally closed (NC)**

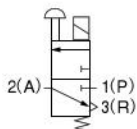

**3-port  
Normally open (NO)**

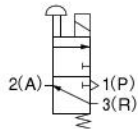

## Specifications

### Basic Models and Functions

Basic model	For direct piping, F type manifold <sup>Note1</sup>			For A type manifold <sup>Note2</sup>		
	CS-G010E1(-11) CS-GV010E1(-11) (standard)	CS-G010LE1(-11) CS-GV010LE1(-11) (low current)	CS-G010HE1(-11) CS-GV010HE1(-11) (large flow)	CS-GA010E1(-11) CS-GAV010E1(-11) (standard)	CS-GA010LE1(-11) CS-GAV010LE1(-11) (low current)	CS-GA010HE1(-11) CS-GAV010HE1(-11) (large flow)
Item						
Number of positions	2 positions					
Number of ports	2, 3 ports					
Valve function	Normally closed (NC, standard) or normally open (NO, option)					

Remark: For optional specifications and order codes, see p.127~128.

Notes: 1. When using the **CS-G010□E1**, **CS-GV010□E1** as a single unit, select it with a mounting base.

2. When using the **CS-GA010□E1**, **CS-GAV010□E1** as a single unit, select it with a sub-base.

## Specifications (Positive Pressure)

Item	Basic model	Direct piping, F type manifold			A type manifold		
		CS-G010E1 (standard)	CS-G010LE1 (low current)	CS-G010HE1 (large flow)	CS-GA010E1 (standard)	CS-GA010LE1 (low current)	CS-GA010HE1 (large flow)
Media	Air						
Operation type	Direct acting type						
Effective area [Cv] mm <sup>2</sup>	1(P)→2(A)	0.2 [0.011]	0.1 [0.006]	0.45 [0.025]	0.2 [0.011]	0.1 [0.006]	0.45 [0.025]
	2(A)→3(R)	0.3 [0.017]	0.2 [0.011]	0.6 [0.033]	0.3 [0.017]	0.2 [0.011]	0.6 [0.033]
Port size	M3×0.5			M5×0.8			
Lubrication	Not required						
Operating pressure range MPa [psi.]	0~0.7 [0~102]						
Proof pressure MPa [psi.]	1.05 [152]						
Response time <sup>Note1</sup> ON/OFF ms	4/8	5/10	3/6	4/8	5/10	3/6	
Maximum operating frequency Hz	5						
Operating temp. range (atmosphere and media) °C [°F] <sup>Note2</sup>	5~50 [41~122]						
Shock resistance m/s <sup>2</sup> [G]	1373.0 [140] (Axial direction 196.2 [20])						
Rated voltage <sup>Note3</sup>	(DC5V,DC6V) DC12V,DC24V AC100V,(AC200V)	(DC5V,DC6V) DC12V,DC24V	(DC12V) DC24V	(DC5V,DC6V) DC12V,DC24V AC100V,(AC200V)	(DC5V,DC6V) DC12V,DC24V	(DC12V) DC24V	
Mounting direction	Any						

Item	Basic model	Direct piping, F type manifold			A type manifold		
		CS-G010E1-11 (standard)	CS-G010LE1-11 (low current)	CS-G010HE1-11 (large flow)	CS-GA010E1-11 (standard)	CS-GA010LE1-11 (low current)	CS-GA010HE1-11 (large flow)
Media	Air						
Operation type	Direct acting type						
Effective area [Cv] mm <sup>2</sup>	2(A)→1(P)	0.3 [0.017]	0.15 [0.008]	0.55 [0.031]	0.3 [0.017]	0.15 [0.008]	0.55 [0.031]
	3(R)→2(A)	0.2 [0.011]	0.1 [0.006]	0.45 [0.025]	0.2 [0.011]	0.1 [0.006]	0.45 [0.025]
Port size	M3×0.5			M5×0.8			
Lubrication	Not required						
Operating pressure range MPa [psi.]	0~0.7 [0~102]		0~0.5 [0~73]	0~0.7 [0~102]		0~0.5 [0~73]	
Proof pressure MPa [psi.]	1.05 [152]						
Response time <sup>Note1</sup> ON/OFF ms	4/8	5/10	3/6	4/8	5/10	3/6	
Maximum operating frequency Hz	5						
Operating temp. range (atmosphere and media) °C [°F] <sup>Note2</sup>	5~50 [41~122]						
Shock resistance m/s <sup>2</sup> [G]	1373.0 [140] (Axial direction 196.2 [20])						
Rated voltage <sup>Note3</sup>	(DC5V,DC6V) DC12V,DC24V AC100V,(AC200V)	(DC5V,DC6V) DC12V,DC24V	(DC12V) DC24V	(DC5V,DC6V) DC12V,DC24V AC100V,(AC200V)	(DC5V,DC6V) DC12V,DC24V	(DC12V) DC24V	
Mounting direction	Any						
Air supply port	3(R) port						

Notes: 1. Values when air pressure is 0.5MPa [73psi.]. Due to switching phase timing, add a maximum of 5ms to the AC response time.

2. Take heat radiation measures to ensure that the ambient temperature (or when used in a control box, the internal temperature of the box) always remains within the temperature range specifications.  
And for long-time continuous energizing, consult us.

3. Values in parentheses ( ) are for made to order items. See the corresponding table of solenoid options/voltage on p.132.

# Specifications (Vacuum)

Basic model		Direct piping, F type manifold			A type manifold		
		CS-GV010E1 (standard)	CS-GV010LE1 (low current)	CS-GV010HE1 (large flow)	CS-GAV010E1 (standard)	CS-GAV010LE1 (low current)	CS-GAV010HE1 (large flow)
Item		Air					
Media		Air					
Operation type		Direct acting type					
Effective area [Cv] mm <sup>2</sup>	1(P)→2(A)	0.3[0.017]	0.15[0.008]	0.55[0.031]	0.3[0.017]	0.15[0.008]	0.55[0.031]
	2(A)→3(R)	0.2[0.011]	0.1[0.006]	0.45[0.025]	0.2[0.011]	0.1[0.006]	0.45[0.025]
Port size		M3×0.5			M5×0.8		
Lubrication		Not required					
Operating pressure range MPa [psi.]	1(P) port	-100kPa~0 [-29.53in.Hg~0]					
	3(R) port	0~0.5 [0~73]		0~0.4 [0~58]		0~0.5 [0~73]	
Proof pressure MPa [psi.]		1.05 [152]					
Response time <sup>Note 1</sup> ON/OFF ms		4/8	5/10	3/6	4/8	5/10	3/6
Maximum operating frequency Hz		5					
Operating temp. range (atmosphere and media) °C [°F] <sup>Note 2</sup>		5~50 [41~122]					
Shock resistance m/s <sup>2</sup> {G}		1373.0 {140} (Axial direction 196.2 {20})					
Rated voltage <sup>Note 3</sup>		(DC5V,DC6V) DC12V,DC24V AC100V,(AC200V)	(DC5V,DC6V) DC12V,DC24V	(DC12V) DC24V	(DC5V,DC6V) DC12V,DC24V AC100V,(AC200V)	(DC5V,DC6V) DC12V,DC24V	(DC12V) DC24V
Mounting direction		Any					
Air supply port	Vacuum	1(P) port					
	Positive pressure	3(R) port					

Basic model		Direct piping, F type manifold			A type manifold		
		CS-GV010E1-11 (standard)	CS-GV010LE1-11 (low current)	CS-GV010HE1-11 (large flow)	CS-GAV010E1-11 (standard)	CS-GAV010LE1-11 (low current)	CS-GAV010HE1-11 (large flow)
Item		Air					
Media		Air					
Operation type		Direct acting type					
Effective area [Cv] mm <sup>2</sup>	2(A)→1(P)	0.2[0.011]	0.1[0.006]	0.45[0.025]	0.2[0.011]	0.1[0.006]	0.45[0.025]
	3(R)→2(A)	0.3[0.017]	0.2[0.011]	0.6[0.033]	0.3[0.017]	0.2[0.011]	0.6[0.033]
Port size		M3×0.5			M5×0.8		
Lubrication		Not required					
Operating pressure range MPa [psi.]	1(P) port	0~0.5 [0~73]		0~0.4 [0~58]		0~0.5 [0~73]	
	3(R) port	-100kPa~0 [-29.53in.Hg~0]					
Proof pressure MPa [psi.]		1.05 [152]					
Response time <sup>Note 1</sup> ON/OFF ms		4/8	5/10	3/6	4/8	5/10	3/6
Maximum operating frequency Hz		5					
Operating temp. range (atmosphere and media) °C [°F] <sup>Note 2</sup>		5~50 [41~122]					
Shock resistance m/s <sup>2</sup> {G}		1373.0 {140} (Axial direction 196.2 {20})					
Rated voltage <sup>Note 3</sup>		(DC5V,DC6V) DC12V,DC24V AC100V,(AC200V)	(DC5V,DC6V) DC12V,DC24V	(DC12V) DC24V	(DC5V,DC6V) DC12V,DC24V AC100V,(AC200V)	(DC5V,DC6V) DC12V,DC24V	(DC12V) DC24V
Mounting direction		Any					
Air supply port	Vacuum	3(R) port					
	Positive pressure	1(P) port					

- Notes: 1. Values when air pressure is 0.5MPa [73psi.]. Due to the switching phase timing, add a maximum of 5ms to the AC response time.  
 2. Take heat radiation measures to ensure that the ambient temperature (or when used in a control box, the internal temperature of the box) always remains within the temperature range specifications.  
 And for long-time continuous energizing, consult us.  
 3. Values in parentheses ( ) are for made to order items. See the corresponding table of solenoid options/voltage on p.132.

## Solenoid Specifications

Rated voltage		DC5V	DC6V	DC12V	DC24V	AC100V <small>Note</small>	AC200V <small>Note</small>
Operating voltage range	V	4.5~5.5 (5±10%)	5.4~6.6 (6±10%)	10.8~13.2 (12±10%)	21.6~26.4 (24±10%)	90~110 (100±10%)	180~220 (200±10%)
CS-G(A)(V)010E1	Current (when rated voltage is applied) mA(r.m.s)	200	168	84	42	11	8
	Power consumption	1.0W				1.1VA	1.6VA
	Allowable leakage current mA	2.0				1.0	
CS-G(A)(V)010E1	Current (when rated voltage is applied) mA(r.m.s)	100	84	42	21	_____	_____
	Power consumption	0.5W				_____	_____
	Allowable leakage current mA	1.0				_____	_____
CS-G(A)(V)010HE1	Current (when rated voltage is applied)	Starting mA	_____	267	133	_____	_____
		Holding mA	_____	92	46	_____	_____
	Power consumption	Starting W	_____	3.2		_____	_____
		Holding W	_____	1.1		_____	_____
	Allowable leakage current mA	_____	10	5	_____	_____	
	Start-up time (standard time) ms	_____	48	27	_____	_____	
Insulation resistance	MΩ	Over 100					
Wiring type and lead wire length		Grommet type: 300mm [11.8in.], Plug connector type: 300mm [11.8in.]					
Color of lead wire		Red (+), Black (-)				Yellow	White
Color of LED indicator		Red					
Surge suppression (as standard)		Flywheel diode				Bridge diode	

Note: Since the AC types have built-in bridge diodes, the starting current value and energizing current value are virtually the same. In addition, the rated frequencies are 50Hz and 60Hz. Specification values are the same for both.

# Order Codes

		2-, 3-port valve Number of ports	2-, 3-port valve Valve function	Mounting base	Sub-base	Wiring type	Voltage		
		3-port  Blank	Blank Normally closed (NC)	Without mounting base  Blank	Without sub-base  Blank	● Lead wire length: 300mm [11.8in.] is standard. Grommet type with LED Indicator  Blank			
		2-port  -2	-11 Normally open (NO)	With mounting base  -21 ● Attached to a valve body at shipping.	With sub-base  -25 ● Attached to a valve body at shipping.	Straight connector with LED indicator  -PS			
						L connector with LED Indicator  -PL			
Direct piping	Positive pressure	2-, 3-port standard type	CS-G010E1	-2	-11 Note 2	-21 Note 1	-PS	-PL	DC12V,DC24V,AC100V
		2-, 3-port low current type	CS-G010LE1						DC12V,DC24V
		2-, 3-port large flow type	CS-G010HE1						DC24V
	Vacuum	2-, 3-port standard type	CS-GV010E1						DC12V,DC24V,AC100V
		2-, 3-port low current type	CS-GV010LE1						DC12V,DC24V
		2-, 3-port large flow type	CS-GV010HE1						DC24V
Sub-base piping	Positive pressure	2-, 3-port standard type	CS-GA010E1	-2	-11 Note 2	-25 Note 1	-PS	-PL	DC12V,DC24V,AC100V
		2-, 3-port low current type	CS-GA010LE1						DC12V,DC24V
		2-, 3-port large flow type	CS-GA010HE1						DC24V
	Vacuum	2-, 3-port standard type	CS-GAV010E1						DC12V,DC24V,AC100V
		2-, 3-port low current type	CS-GAV010LE1						DC12V,DC24V
		2-, 3-port large flow type	CS-GAV010HE1						DC24V

Notes: 1. When using the solenoid valve as a single unit, always select it either with mounting base or with sub-base.  
 2. Normally closed (NC) and normally open (NO) valves cannot be mounted together on the same manifold.

## Made to Order (After the wiring order code, enter the codes below.)

Straight connector with LED indicator Negative common  <b>-MS</b>	L connector with LED indicator Negative common  <b>-ML</b>	Lead wire length  <b>-1L</b> <b>-3L</b> ● For plug connector ● Length -1L: 1000 [39in.] (mm) -3L: 3000 [118in.]	Voltage specifications ● CS-G□010E1: DC5V,DC6V,AC200V ● CS-G□010LE1: DC5V,DC6V ● CS-G□010HE1: DC12V ● For AC110V~120V, AC220V~240V specifications, consult us.				
Straight connector with LED indicator (Without connector, contact and lead wire) Negative common  <b>-MSX</b>	Straight connector with LED indicator (Without connector, contact and lead wire) Positive common  <b>-PSX</b>	L connector with LED indicator (Without connector, contact and lead wire) Negative common  <b>-MLX</b>	L connector with LED indicator (Without connector, contact and lead wire) Positive common  <b>-PLX</b>	Straight connector with LED indicator (Connector, contact included.) Without lead wire Negative common  <b>-MSN</b>	Straight connector with LED indicator (Connector, contact included.) Without lead wire Positive common  <b>-PSN</b>	L connector with LED indicator (Connector, contact included.) Without lead wire Negative common  <b>-MLN</b>	L connector with LED indicator (Connector, contact included.) Without lead wire Positive common  <b>-PLN</b>

# Manifold Order Codes

Manifold model Number of units		Station	Basic model	2, 3-port valve Number of ports	2, 3-port valve Valve function	Wiring type	Voltage						
P, R port (M5X0.8) type <b>CS-G010M</b>	2 ⋮ 20	F	CS-G010E1	Blank	Blank Normally closed (NC)	Blank	DC12V,DC24V,AC100V						
			CS-G010LE1				DC12V,DC24V						
			CS-G010HE1				DC24V						
			CS-GV010E1				DC12V,DC24V,AC100V						
			CS-GV010LE1				DC12V,DC24V						
			CS-GV010HE1				DC24V						
		A	CS-GA010E1	-2	-11	-PS -PL	DC12V,DC24V,AC100V						
			CS-GA010LE1				DC12V,DC24V						
			CS-GA010HE1				DC24V						
			CS-GAV010E1				DC12V,DC24V,AC100V						
			CS-GAV010LE1				DC12V,DC24V						
			CS-GAV010HE1				DC24V						
			P, R port (Rc1/8) type <b>CS-G010MH</b>				2 ⋮ 20	F	CS-G010E1	Blank	Blank Normally closed (NC)	Blank	DC12V,DC24V,AC100V
									CS-G010LE1				DC12V,DC24V
CS-G010HE1	DC24V												
CS-GV010E1	DC12V,DC24V,AC100V												
CS-GV010LE1	DC12V,DC24V												
CS-GV010HE1	DC24V												
A	CS-GA010E1	-2		-11	-PS -PL	DC12V,DC24V,AC100V							
	CS-GA010LE1					DC12V,DC24V							
	CS-GA010HE1					DC24V							
	CS-GAV010E1					DC12V,DC24V,AC100V							
	CS-GAV010LE1					DC12V,DC24V							
	CS-GAV010HE1					DC24V							

● Valve mounting location from the left-hand side when facing the 2(A) port (□: 1~20)

- Specify the valve type for each station.
- Enter -BP when closing a station with a block-off plate without mounting a valve.
- Normally closed (NC) and normally open (NO) valves cannot be mounted together on the same manifold.

## Additional Parts (To be ordered separately)

Mounting base



● For direct piping (With gasket)

Mounting base



● For direct piping. For CS-G010HE1-11, CS-GV010HE1 only (With gasket).

Sub-base



● For sub-base piping (With gasket)

Lead wire for common wiring

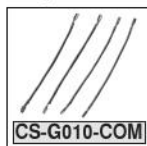

● For -PS, -PL, -MS, -ML (Set of 10 pcs.)

Common pre-wired lead wire assembly

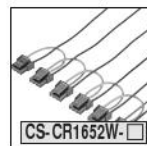

● For details, see the Valves General Catalog.

Block-off plate



# Operating Principles and Major Parts

## 3-port

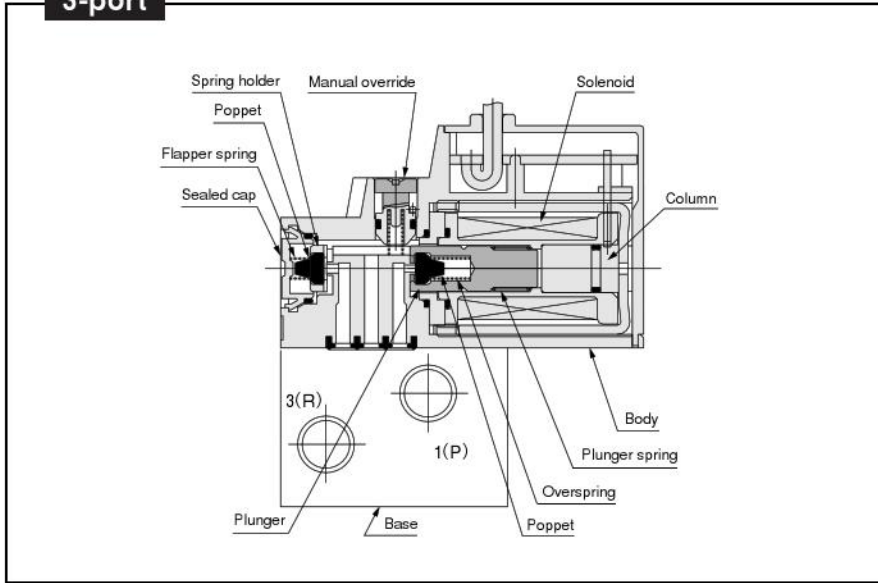

### Major Parts and Materials

Parts		Materials
Valve	Body	Plastic
	Poppet	Synthetic rubber
	Plunger	Magnetic stainless steel
	Column	
	Base	Aluminum alloy (anodized)
Manifold	Body	Aluminum alloy (anodized)
	Block-off plate	Plastic
	Seal	Synthetic rubber

### Corresponding Table of Mounting Valve and Manifold

Valve specifications				Valve options				Applicable manifolds			
Piping configuration	Basic model	Power	Flow rate	-2 (2-port)	-1 <sup>Note 1</sup> (Normally open, NO)	-21 (Mounting base)	-25 (Sub-base)	CS-G010M□F	CS-G010M□A	CS-G010MH□F	CS-G010MH□A
Direct piping	CS-G010E1	1.0W	Standard	●	●	●	□	●	□	●	□
	CS-G010LE1	0.5W	Small flow	●	●	●	□	●	□	●	□
	CS-G010HE1	3.2W (1.1W) <sup>Note 2</sup>	Large flow	●	●	●	□	●	□	●	□
	CS-GV010E1	1.0W	Standard	●	●	●	□	●	□	●	□
	CS-GV010LE1	0.5W	Small flow	●	●	●	□	●	□	●	□
	CS-GV010HE1	3.2W (1.1W) <sup>Note 2</sup>	Large flow	●	●	●	□	●	□	●	□
Base piping	CS-GA010E1	1.0W	Standard	●	●	□	●	●	□	●	●
	CS-GA010LE1	0.5W	Small flow	●	●	□	●	●	□	●	●
	CS-GA010HE1	3.2W (1.1W) <sup>Note 2</sup>	Large flow	●	●	□	●	●	□	●	●
	CS-GAV010E1	1.0W	Standard	●	●	□	●	●	□	●	●
	CS-GAV010LE1	0.5W	Small flow	●	●	□	●	●	□	●	●
	CS-GAV010HE1	3.2W (1.1W) <sup>Note 2</sup>	Large flow	●	●	□	●	●	□	●	●
2(A) port								(M3)	M3	(M3)	M5
1(P), 3(R) port								M5	M5	Rc1/8	Rc1/8

●: Selectable or mountable

Notes: 1. Care should be taken when ordering, since the initial settings for the normally closed (NC) and normally open (NO) valves cannot be changed later on.  
Normally closed (NC) and normally open (NO) valves cannot be mounted together on the same manifold.

2. Values in parentheses ( ) in power column are for holding state.

## Dimensions of Direct Piping Solenoid Valve mm [in.]

CS-G010E1(-11)-21 (DC5V, DC6V, DC12V, DC24V, AC100V)

CS-G010LE1(-11)-21

CS-G010HE1-21

CS-GV010E1(-11)-21

CS-GV010LE1(-11)-21

CS-GV010HE1-11-21

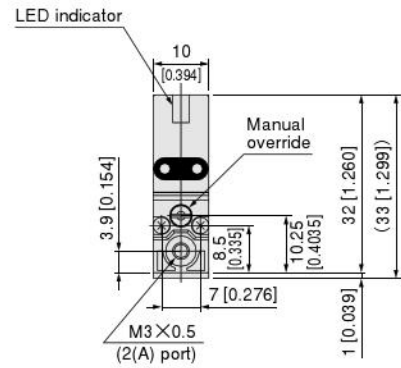
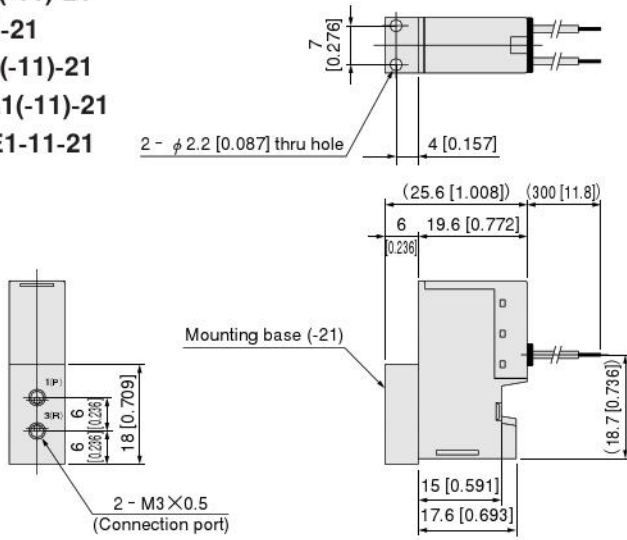

CS-G010HE1-11-21 (DC24V)

CS-GV010HE1-21

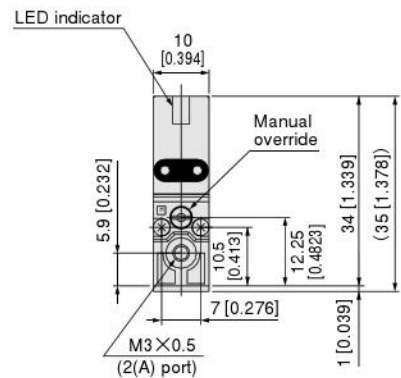
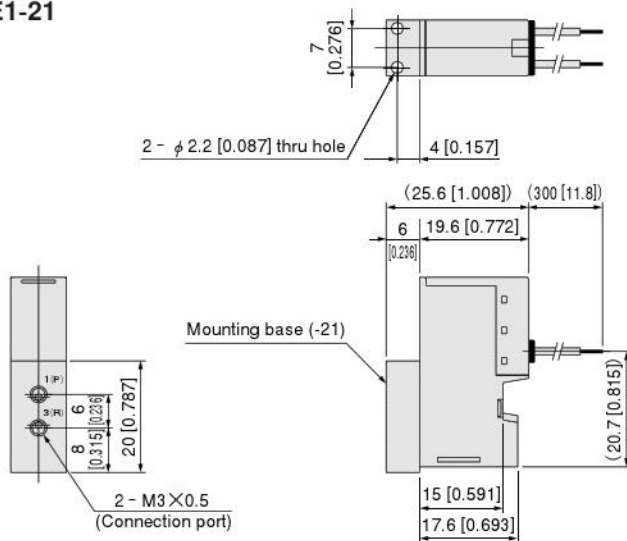

CS-G010E1(-11)-21 (AC200V)

CS-GV010E1(-11)-21

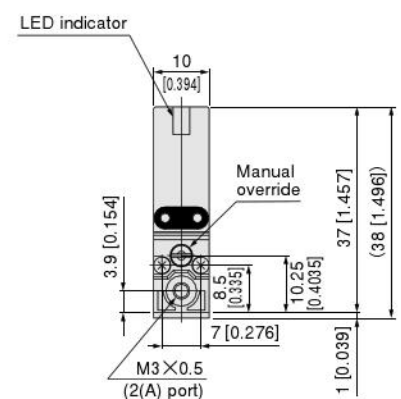
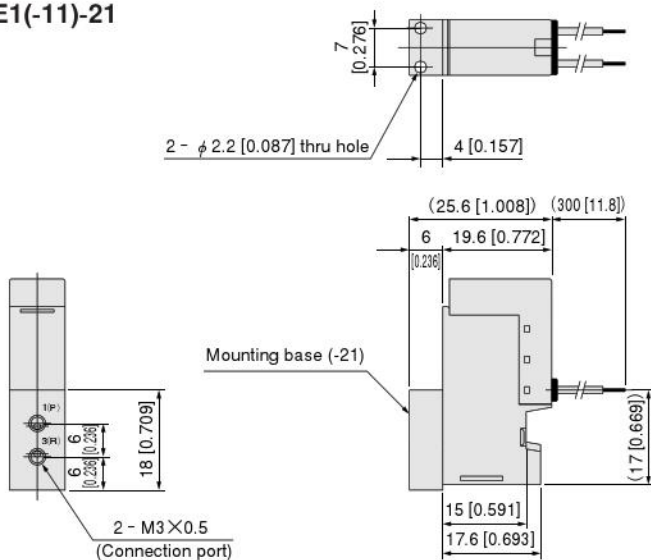

**Dimensions of Sub-base Piping Solenoid Valve mm [in.]**

**CS-GA010E1(-11)-25 (DC5V, DC6V, DC12V, DC24V, AC100V)**

**CS-GA010LE1(-11)-25**

**CS-GA010HE1-25**

**CS-GAV010E1(-11)-25**

**CS-GAV010LE1(-11)-25**

**CS-GAV010HE1-11-25**

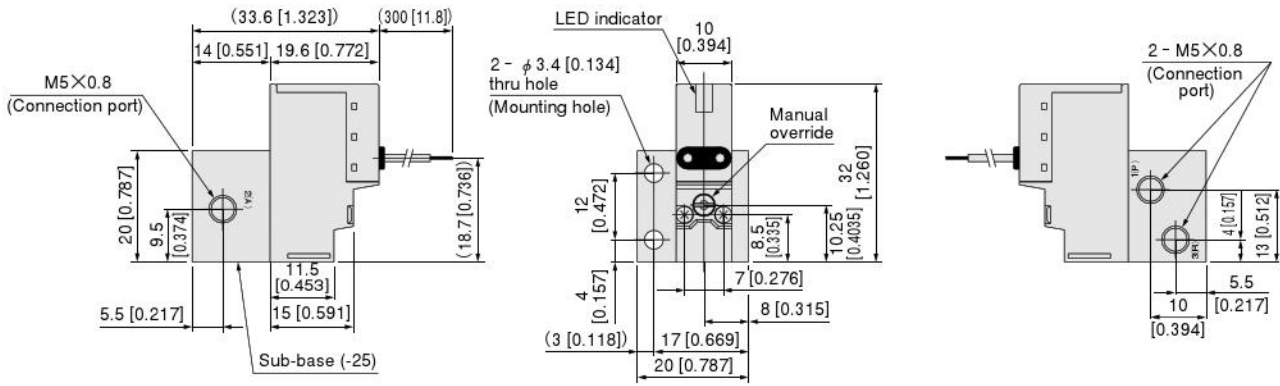

**CS-GA010HE1-11-25 (DC24V)**

**CS-GAV010HE1-25**

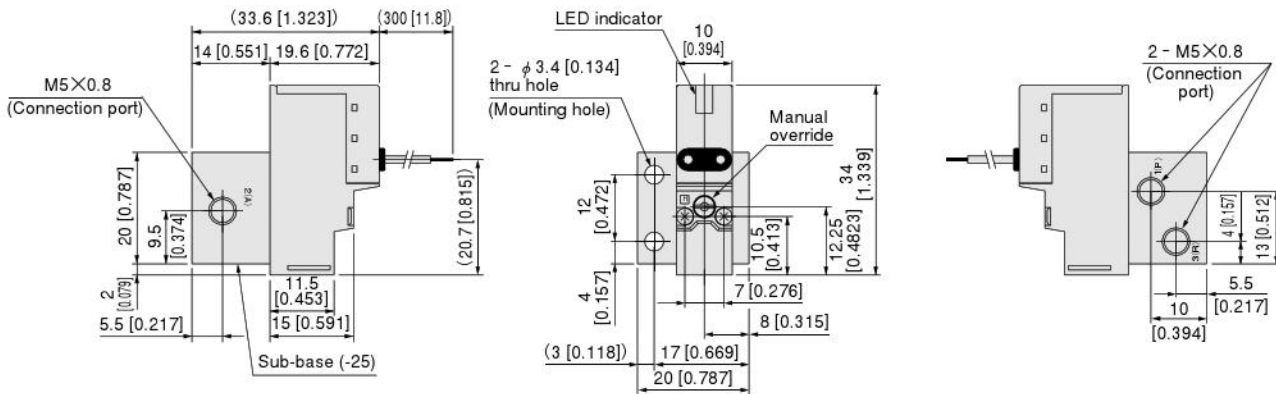

**CS-GA010E1(-11)-25 (AC200V)**

**CS-GAV010E1(-11)-25**

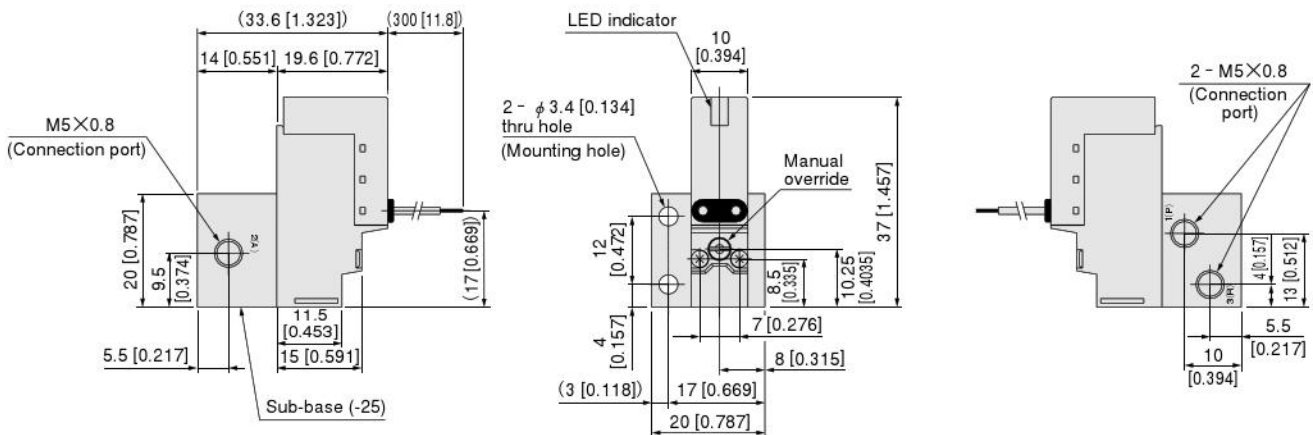

# Dimensions of Connector mm [in.]

## Options

● Solenoid with L connector: -PL

● Solenoid with straight connector: -PS

● Solenoid with L connector (AC200V): -PL

● Solenoid with straight connector (AC200V): -PS

Made to order connectors are the same dimensions in the drawings.

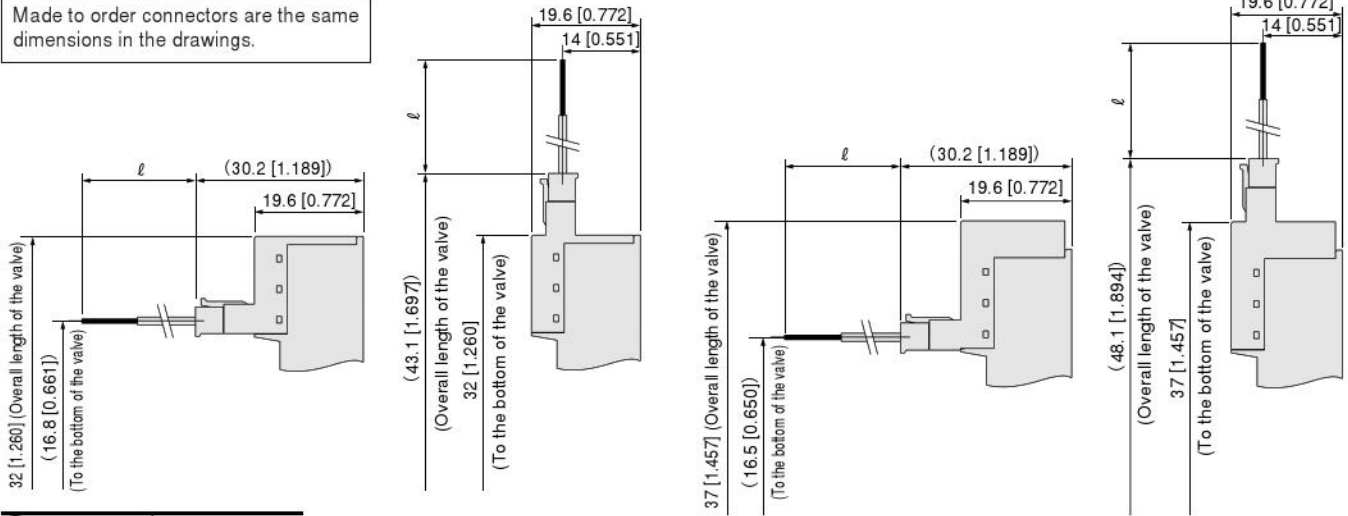

Model	Code	ℓ
Blank	300	[11.8]
-1L	1000	[39]
-3L	3000	[118]

## Corresponding Table of Solenoid Options and Voltage

Basic valve models	Voltage specifications	Connector specifications													
		Blank (grommet)	-PS	-PL	-MS	-ML	-PSX	-PLX	-MSX	-MLX	-PSN	-PLN	-MSN	-MLN	
CS-G(A)010E1 [-11] CS-G(A)V010E1 [-11] (standard type)	DC5V	△	△	△	△	△	△	△	△	△	△	△	△	△	
	DC6V	△	△	△	△	△	△	△	△	△	△	△	△	△	
	DC12V	●	●	●	△	△	△	△	△	△	△	△	△	△	
	DC24V	●	●	●	△	△	△	△	△	△	△	△	△	△	
	AC100V	●	●	●	△	△	△	△	△	△	△	△	△	△	
	AC200V	△	△	△	△	△	△	△	△	△	△	△	△	△	
CS-G(A)010LE1 [-11] CS-G(A)V010LE1 [-11] (low current type)	DC5V	△	△	△	△	△	△	△	△	△	△	△	△		
	DC6V	△	△	△	△	△	△	△	△	△	△	△	△		
	DC12V	●	●	●	△	△	△	△	△	△	△	△	△		
	DC24V	●	●	●	△	△	△	△	△	△	△	△	△		
CS-G(A)010HE1 [-11] CS-G(A)V010HE1 [-11] (large flow type)	DC12V	△	△	△	△	△	△	△	△	△	△	△	△		
	DC24V	●	●	●	△	△	△	△	△	△	△	△	△		
Lead wire length options same for all basic models	-1L	△	△	△	△	△	△	△	△	△	△	△	△		
	-3L	△	△	△	△	△	△	△	△	△	△	△	△		

●: Standard specifications △: Made to order

**Dimensions of F Type Manifold (for Direct Piping with Positive Pressure Solenoid Valves) mm [in.]**

**CS-G010M□F (1(P), 3(R) port: M5×0.8)**

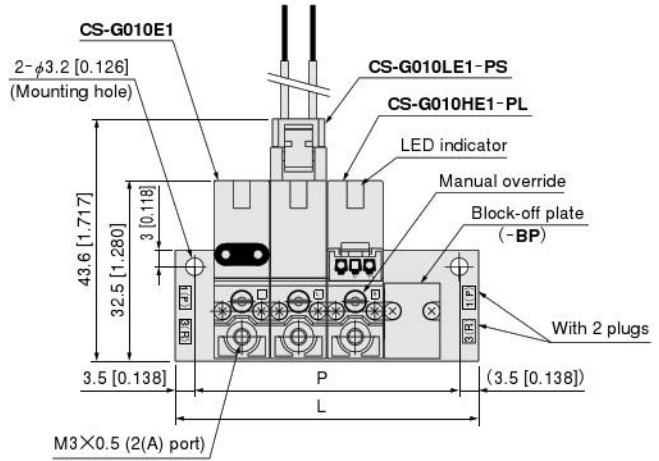
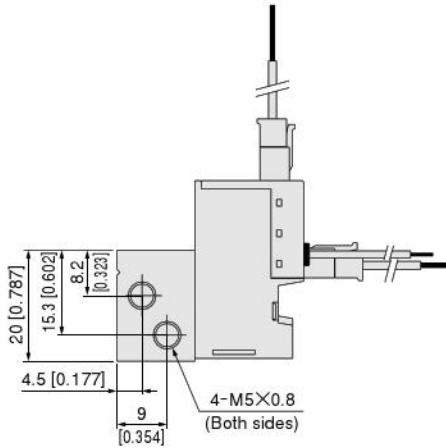

**Unit dimensions**

Number of units	L	P	Number of units	L	P
2	34.2 [1.346]	27.2 [1.071]	12	136.2 [5.362]	129.2 [5.087]
3	44.4 [1.748]	37.4 [1.472]	13	146.4 [5.764]	139.4 [5.488]
4	54.6 [2.150]	47.6 [1.874]	14	156.6 [6.165]	149.6 [5.890]
5	64.8 [2.551]	57.8 [2.276]	15	166.8 [6.567]	159.8 [6.291]
6	75 [2.953]	68 [2.677]	16	177 [6.969]	170 [6.693]
7	85.2 [3.354]	78.2 [3.079]	17	187.2 [7.370]	180.2 [7.094]
8	95.4 [3.756]	88.4 [3.480]	18	197.4 [7.772]	190.4 [7.496]
9	105.6 [4.157]	98.6 [3.882]	19	207.6 [8.173]	200.6 [7.898]
10	115.8 [4.559]	108.8 [4.283]	20	217.8 [8.575]	210.8 [8.299]
11	126 [4.961]	119 [4.685]	—	—	—

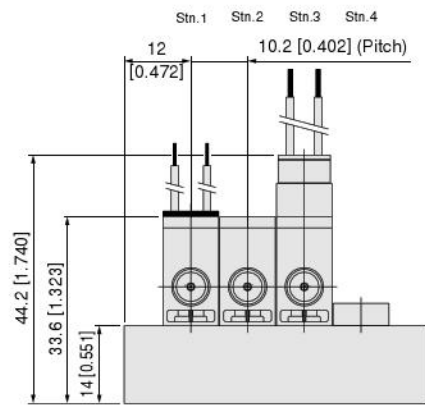

**CS-G010M□F (1(P), 3(R) port: M5×0.8)**

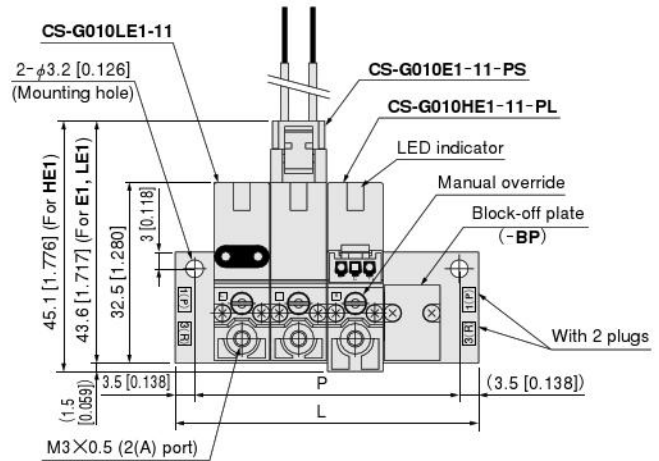
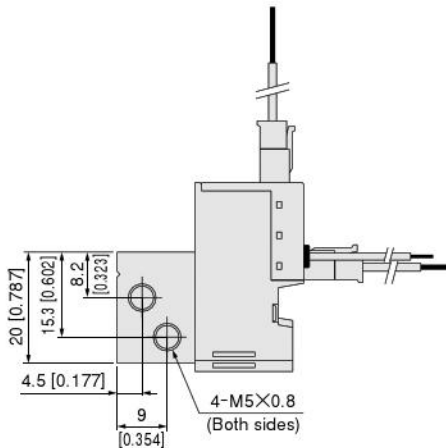

**Unit dimensions**

Number of units	L	P	Number of units	L	P
2	34.2 [1.346]	27.2 [1.071]	12	136.2 [5.362]	129.2 [5.087]
3	44.4 [1.748]	37.4 [1.472]	13	146.4 [5.764]	139.4 [5.488]
4	54.6 [2.150]	47.6 [1.874]	14	156.6 [6.165]	149.6 [5.890]
5	64.8 [2.551]	57.8 [2.276]	15	166.8 [6.567]	159.8 [6.291]
6	75 [2.953]	68 [2.677]	16	177 [6.969]	170 [6.693]
7	85.2 [3.354]	78.2 [3.079]	17	187.2 [7.370]	180.2 [7.094]
8	95.4 [3.756]	88.4 [3.480]	18	197.4 [7.772]	190.4 [7.496]
9	105.6 [4.157]	98.6 [3.882]	19	207.6 [8.173]	200.6 [7.898]
10	115.8 [4.559]	108.8 [4.283]	20	217.8 [8.575]	210.8 [8.299]
11	126 [4.961]	119 [4.685]	—	—	—

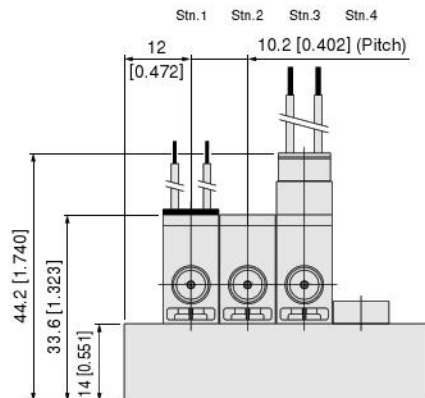

For optional wiring, see p.132.

# Dimensions of F Type Manifold (for Direct Piping with Vacuum Solenoid Valves) mm [in.]

CS-G010M□F (1(P), 3(R) port: M5×0.8)

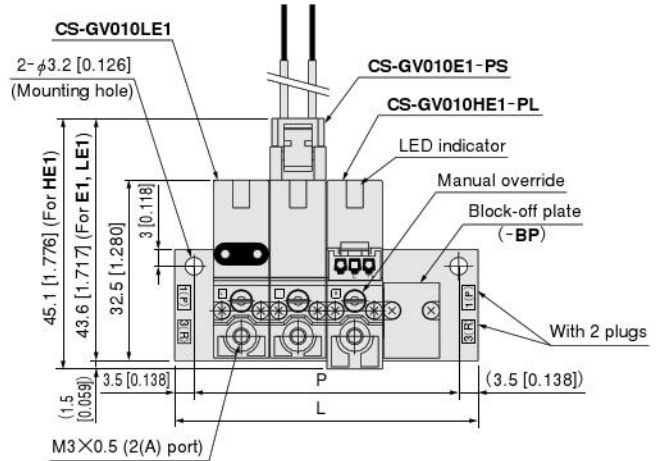
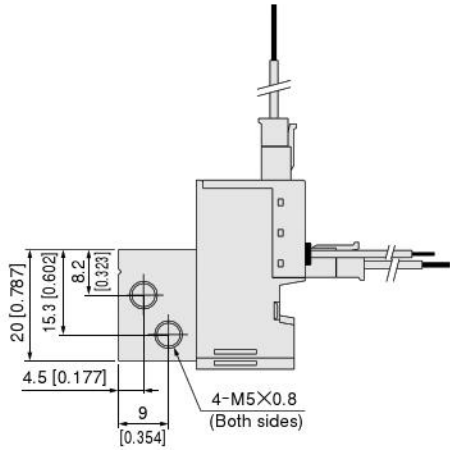

## Unit dimensions

Number of units	L	P	Number of units	L	P
2	34.2 [1.346]	27.2 [1.071]	12	136.2 [5.362]	129.2 [5.087]
3	44.4 [1.748]	37.4 [1.472]	13	146.4 [5.764]	139.4 [5.488]
4	54.6 [2.150]	47.6 [1.874]	14	156.6 [6.165]	149.6 [5.890]
5	64.8 [2.551]	57.8 [2.276]	15	166.8 [6.567]	159.8 [6.291]
6	75 [2.953]	68 [2.677]	16	177 [6.969]	170 [6.693]
7	85.2 [3.354]	78.2 [3.079]	17	187.2 [7.370]	180.2 [7.094]
8	95.4 [3.756]	88.4 [3.480]	18	197.4 [7.772]	190.4 [7.496]
9	105.6 [4.157]	98.6 [3.882]	19	207.6 [8.173]	200.6 [7.898]
10	115.8 [4.559]	108.8 [4.283]	20	217.8 [8.575]	210.8 [8.299]
11	126 [4.961]	119 [4.685]	—	—	—

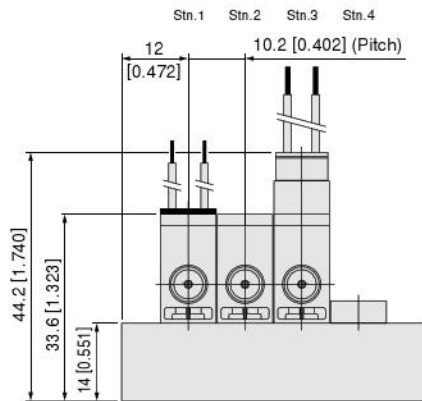

CS-G010M□F (1(P), 3(R) port: M5×0.8)

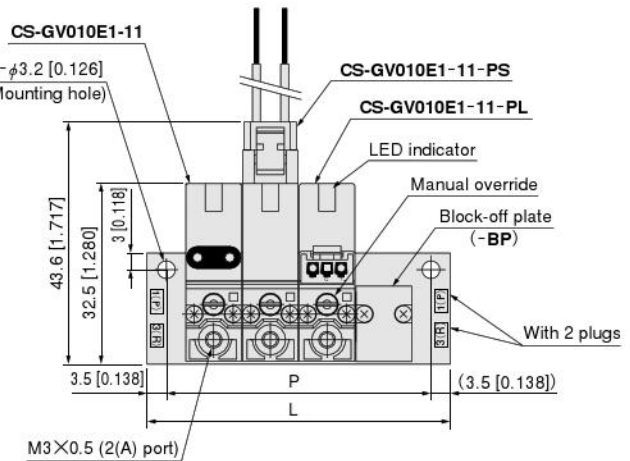
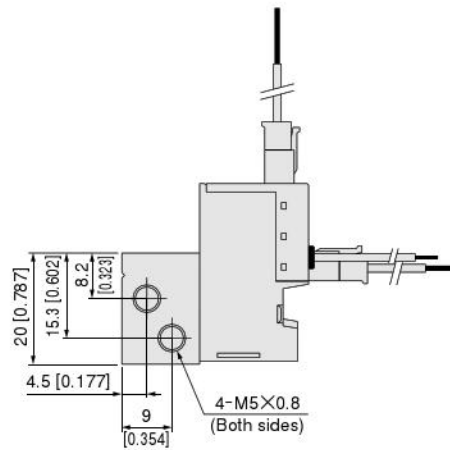

## Unit dimensions

Number of units	L	P	Number of units	L	P
2	34.2 [1.346]	27.2 [1.071]	12	136.2 [5.362]	129.2 [5.087]
3	44.4 [1.748]	37.4 [1.472]	13	146.4 [5.764]	139.4 [5.488]
4	54.6 [2.150]	47.6 [1.874]	14	156.6 [6.165]	149.6 [5.890]
5	64.8 [2.551]	57.8 [2.276]	15	166.8 [6.567]	159.8 [6.291]
6	75 [2.953]	68 [2.677]	16	177 [6.969]	170 [6.693]
7	85.2 [3.354]	78.2 [3.079]	17	187.2 [7.370]	180.2 [7.094]
8	95.4 [3.756]	88.4 [3.480]	18	197.4 [7.772]	190.4 [7.496]
9	105.6 [4.157]	98.6 [3.882]	19	207.6 [8.173]	200.6 [7.898]
10	115.8 [4.559]	108.8 [4.283]	20	217.8 [8.575]	210.8 [8.299]
11	126 [4.961]	119 [4.685]	—	—	—

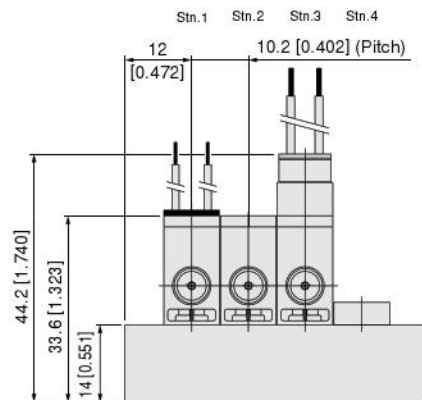

For optional wiring, see p.132.

**Dimensions of F Type Manifold (for Direct Piping with Positive Pressure Solenoid Valves) mm [in.]**

**CS-G010MH□F (1(P), 3(R) port: Rc1/8)**

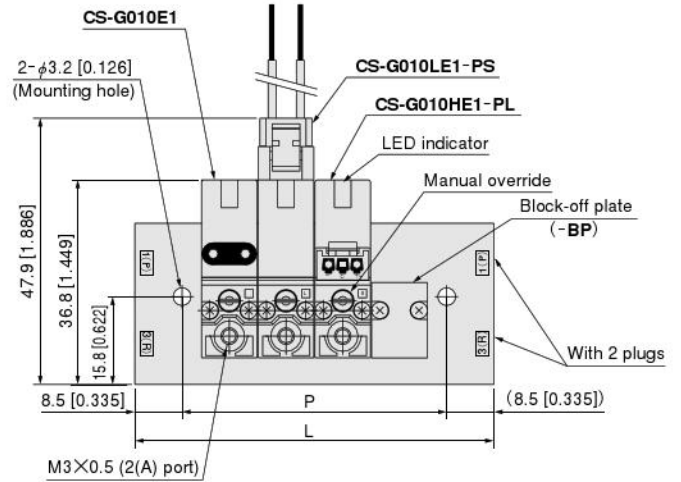
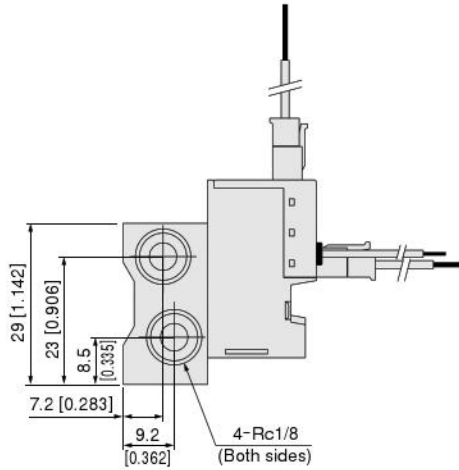

**Unit dimensions**

Number of units	L	P	Number of units	L	P
2	44.2 [1.740]	27.2 [1.071]	12	146.2 [5.756]	129.2 [5.087]
3	54.4 [2.142]	37.4 [1.472]	13	156.4 [6.157]	139.4 [5.488]
4	64.6 [2.543]	47.6 [1.874]	14	166.6 [6.559]	149.6 [5.890]
5	74.8 [2.945]	57.8 [2.276]	15	176.8 [6.961]	159.8 [6.291]
6	85 [3.346]	68 [2.677]	16	187 [7.362]	170 [6.693]
7	95.2 [3.748]	78.2 [3.079]	17	197.2 [7.764]	180.2 [7.094]
8	105.4 [4.150]	88.4 [3.480]	18	207.4 [8.165]	190.4 [7.496]
9	115.6 [4.551]	98.6 [3.882]	19	217.6 [8.567]	200.6 [7.898]
10	125.8 [4.953]	108.8 [4.283]	20	227.8 [8.969]	210.8 [8.299]
11	136 [5.354]	119 [4.685]	—	—	—

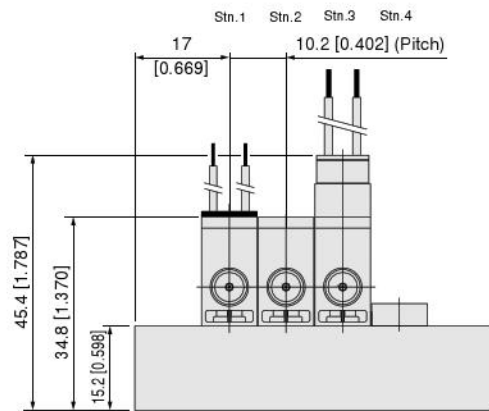

**CS-G010MH□F (1(P), 3(R) port: Rc1/8)**

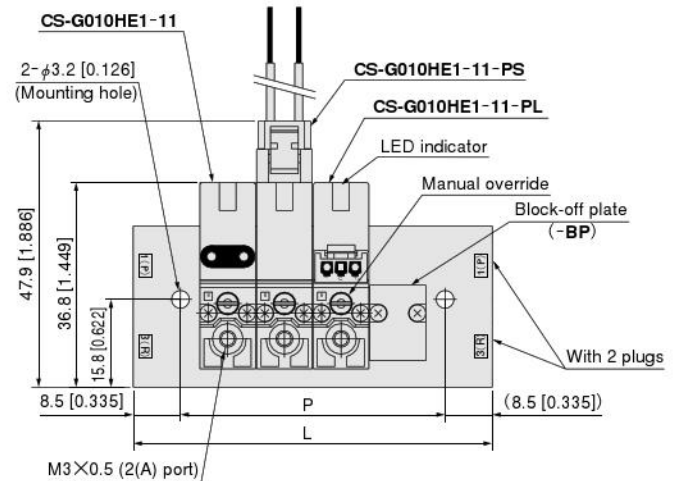
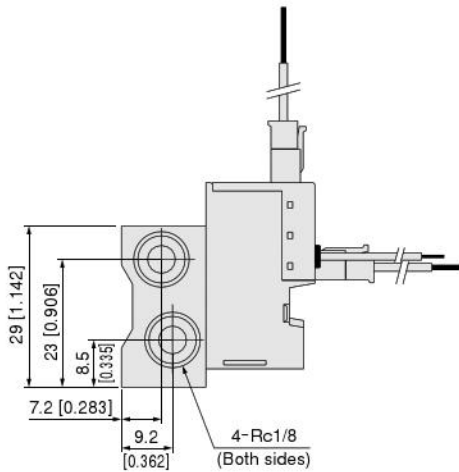

**Unit dimensions**

Number of units	L	P	Number of units	L	P
2	44.2 [1.740]	27.2 [1.071]	12	146.2 [5.756]	129.2 [5.087]
3	54.4 [2.142]	37.4 [1.472]	13	156.4 [6.157]	139.4 [5.488]
4	64.6 [2.543]	47.6 [1.874]	14	166.6 [6.559]	149.6 [5.890]
5	74.8 [2.945]	57.8 [2.276]	15	176.8 [6.961]	159.8 [6.291]
6	85 [3.346]	68 [2.677]	16	187 [7.362]	170 [6.693]
7	95.2 [3.748]	78.2 [3.079]	17	197.2 [7.764]	180.2 [7.094]
8	105.4 [4.150]	88.4 [3.480]	18	207.4 [8.165]	190.4 [7.496]
9	115.6 [4.551]	98.6 [3.882]	19	217.6 [8.567]	200.6 [7.898]
10	125.8 [4.953]	108.8 [4.283]	20	227.8 [8.969]	210.8 [8.299]
11	136 [5.354]	119 [4.685]	—	—	—

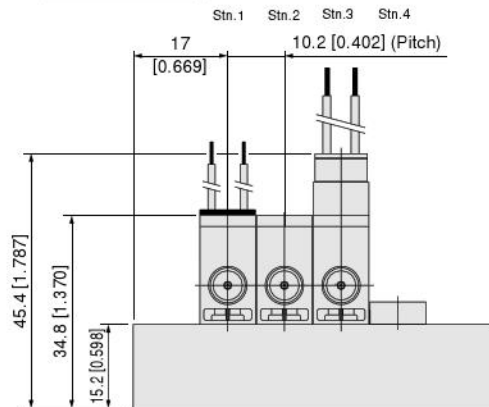

For optional wiring, see p.132.

# Dimensions of F type Manifold (for Direct Piping with Vacuum Solenoid Valves) mm [in.]

CS-G010MH□F (1(P), 3(R) port: Rc1/8)

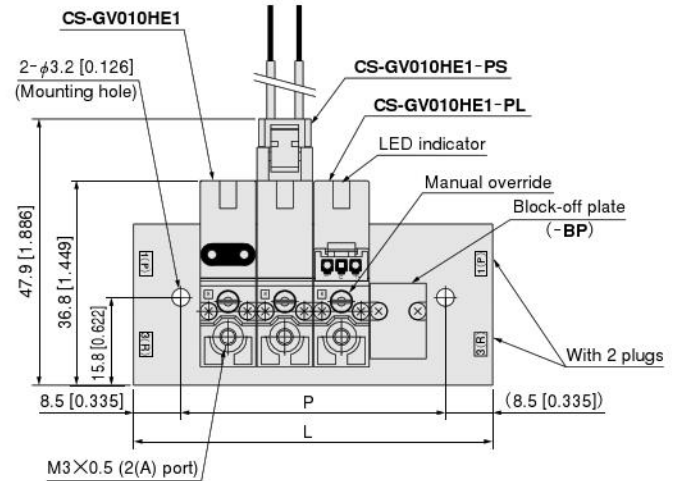
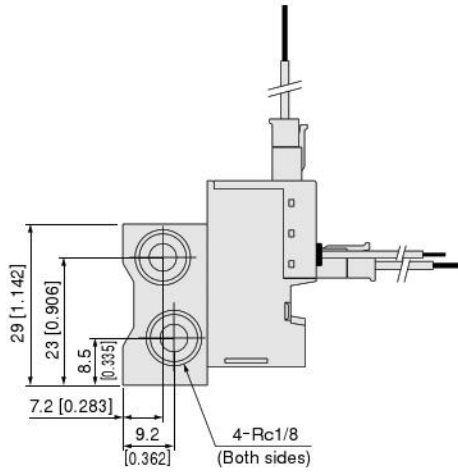

## Unit dimensions

Number of units	L	P	Number of units	L	P
2	44.2 [1.740]	27.2 [1.071]	12	146.2 [5.756]	129.2 [5.087]
3	54.4 [2.142]	37.4 [1.472]	13	156.4 [6.157]	139.4 [5.488]
4	64.6 [2.543]	47.6 [1.874]	14	166.6 [6.559]	149.6 [5.890]
5	74.8 [2.945]	57.8 [2.276]	15	176.8 [6.961]	159.8 [6.291]
6	85 [3.346]	68 [2.677]	16	187 [7.362]	170 [6.693]
7	95.2 [3.748]	78.2 [3.079]	17	197.2 [7.764]	180.2 [7.094]
8	105.4 [4.150]	88.4 [3.480]	18	207.4 [8.165]	190.4 [7.496]
9	115.6 [4.551]	98.6 [3.882]	19	217.6 [8.567]	200.6 [7.898]
10	125.8 [4.953]	108.8 [4.283]	20	227.8 [8.969]	210.8 [8.299]
11	136 [5.354]	119 [4.685]	—	—	—

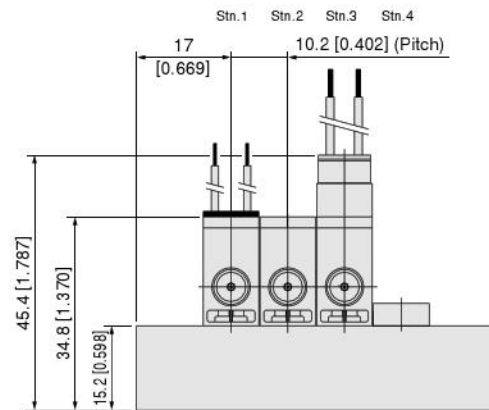

CS-G010MH□F (1(P), 3(R) port: Rc1/8)

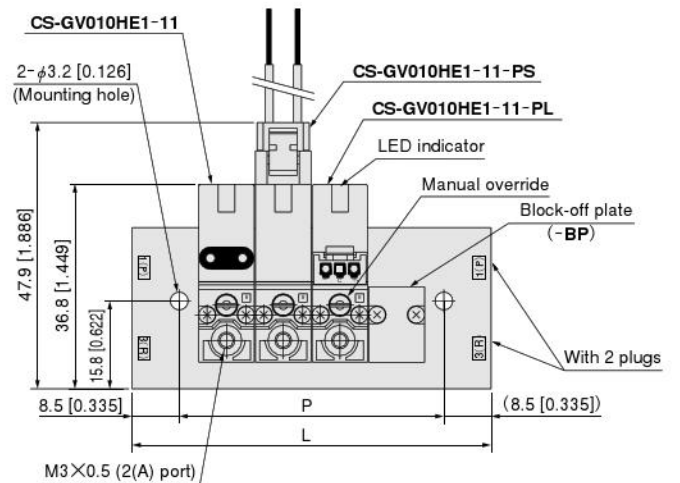
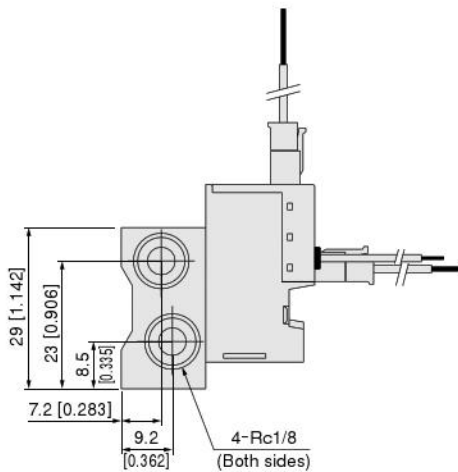

## Unit dimensions

Number of units	L	P	Number of units	L	P
2	44.2 [1.740]	27.2 [1.071]	12	146.2 [5.756]	129.2 [5.087]
3	54.4 [2.142]	37.4 [1.472]	13	156.4 [6.157]	139.4 [5.488]
4	64.6 [2.543]	47.6 [1.874]	14	166.6 [6.559]	149.6 [5.890]
5	74.8 [2.945]	57.8 [2.276]	15	176.8 [6.961]	159.8 [6.291]
6	85 [3.346]	68 [2.677]	16	187 [7.362]	170 [6.693]
7	95.2 [3.748]	78.2 [3.079]	17	197.2 [7.764]	180.2 [7.094]
8	105.4 [4.150]	88.4 [3.480]	18	207.4 [8.165]	190.4 [7.496]
9	115.6 [4.551]	98.6 [3.882]	19	217.6 [8.567]	200.6 [7.898]
10	125.8 [4.953]	108.8 [4.283]	20	227.8 [8.969]	210.8 [8.299]
11	136 [5.354]	119 [4.685]	—	—	—

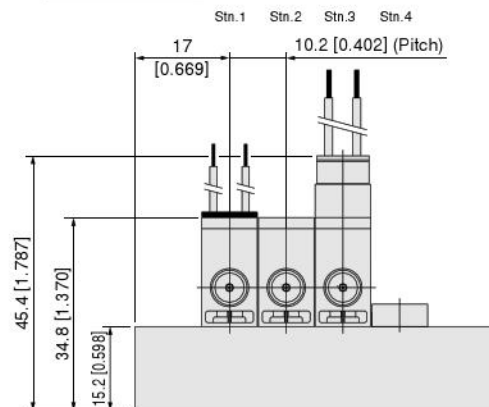

For optional wiring, see p.132.

**Dimensions of A Type Manifold (for Manifold Piping with Positive Pressure Solenoid Valves) mm [in.]**

**CS-G010M□A (1(P), 3(R) port: M5×0.8)**

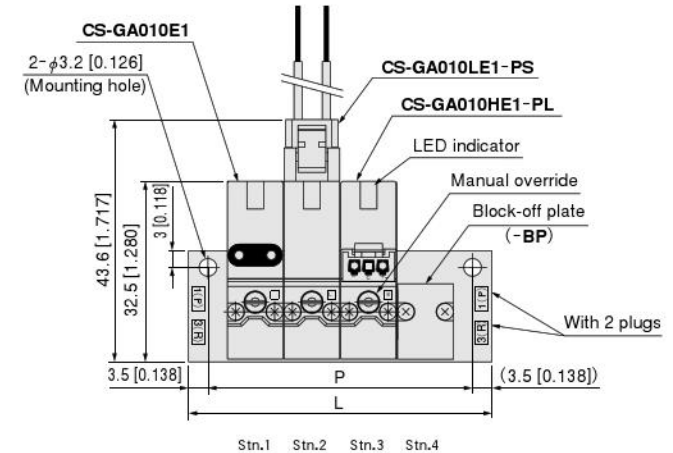
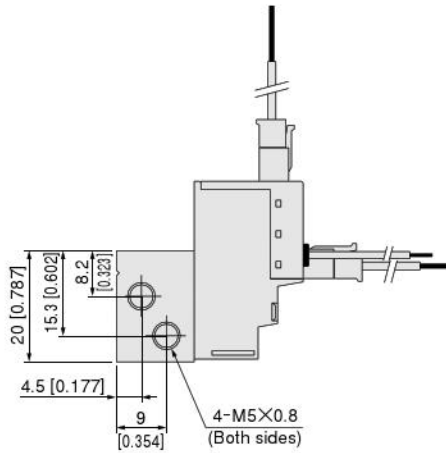

**Unit dimensions**

Number of units	L	P	Number of units	L	P
2	34.2 [1.346]	27.2 [1.071]	12	136.2 [5.362]	129.2 [5.087]
3	44.4 [1.748]	37.4 [1.472]	13	146.4 [5.764]	139.4 [5.488]
4	54.6 [2.150]	47.6 [1.874]	14	156.6 [6.165]	149.6 [5.890]
5	64.8 [2.551]	57.8 [2.276]	15	166.8 [6.567]	159.8 [6.291]
6	75 [2.953]	68 [2.677]	16	177 [6.969]	170 [6.693]
7	85.2 [3.354]	78.2 [3.079]	17	187.2 [7.370]	180.2 [7.094]
8	95.4 [3.756]	88.4 [3.480]	18	197.4 [7.772]	190.4 [7.496]
9	105.6 [4.157]	98.6 [3.882]	19	207.6 [8.173]	200.6 [7.898]
10	115.8 [4.559]	108.8 [4.283]	20	217.8 [8.575]	210.8 [8.299]
11	126 [4.961]	119 [4.685]	—	—	—

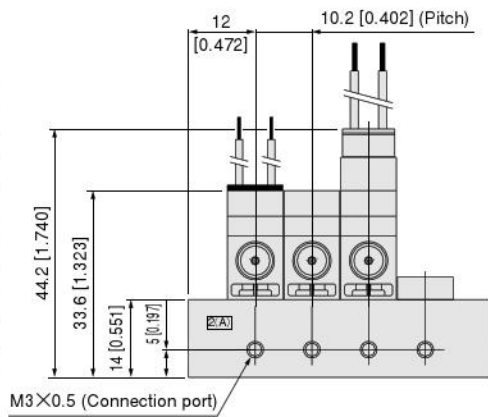

**CS-G010M□A (1(P), 3(R) port: M5×0.8)**

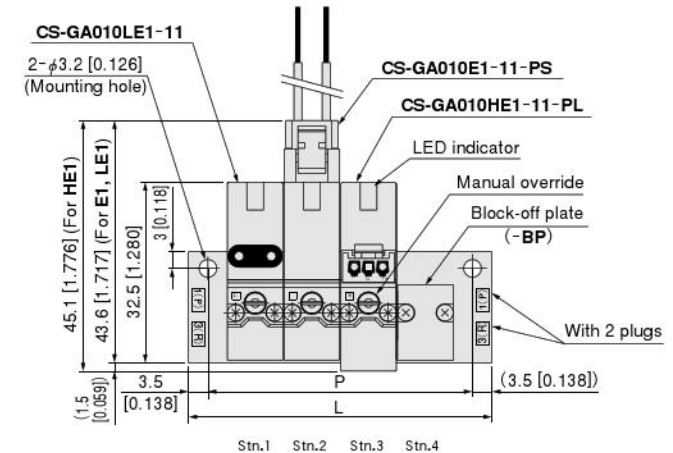
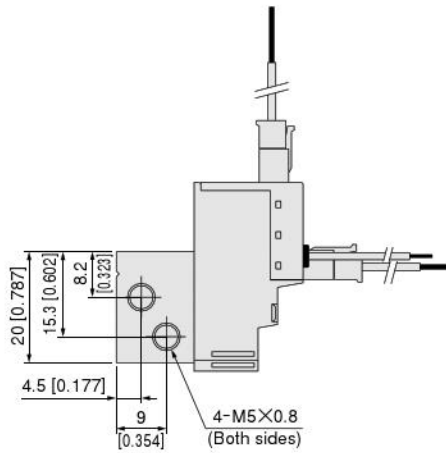

**Unit dimensions**

Number of units	L	P	Number of units	L	P
2	34.2 [1.346]	27.2 [1.071]	12	136.2 [5.362]	129.2 [5.087]
3	44.4 [1.748]	37.4 [1.472]	13	146.4 [5.764]	139.4 [5.488]
4	54.6 [2.150]	47.6 [1.874]	14	156.6 [6.165]	149.6 [5.890]
5	64.8 [2.551]	57.8 [2.276]	15	166.8 [6.567]	159.8 [6.291]
6	75 [2.953]	68 [2.677]	16	177 [6.969]	170 [6.693]
7	85.2 [3.354]	78.2 [3.079]	17	187.2 [7.370]	180.2 [7.094]
8	95.4 [3.756]	88.4 [3.480]	18	197.4 [7.772]	190.4 [7.496]
9	105.6 [4.157]	98.6 [3.882]	19	207.6 [8.173]	200.6 [7.898]
10	115.8 [4.559]	108.8 [4.283]	20	217.8 [8.575]	210.8 [8.299]
11	126 [4.961]	119 [4.685]	—	—	—

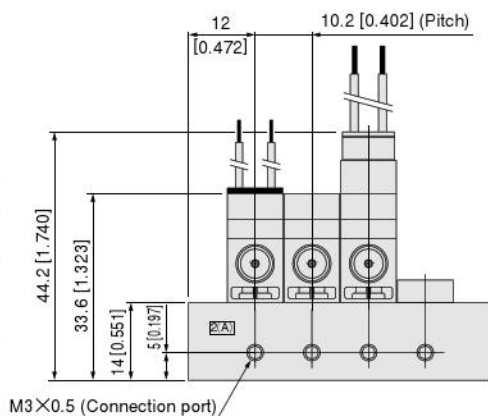

For optional wiring, see p.132.

# Dimensions of A Type Manifold (for Manifold Piping with Vacuum Solenoid Valves) mm [in.]

CS-G010M□A (1(P), 3(R) port: M5×0.8)

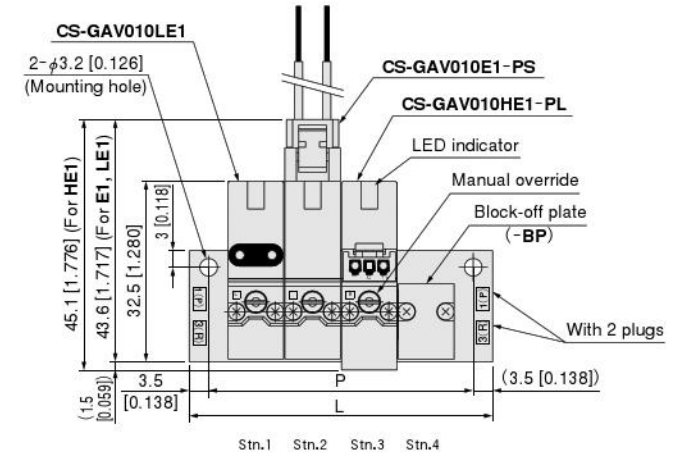
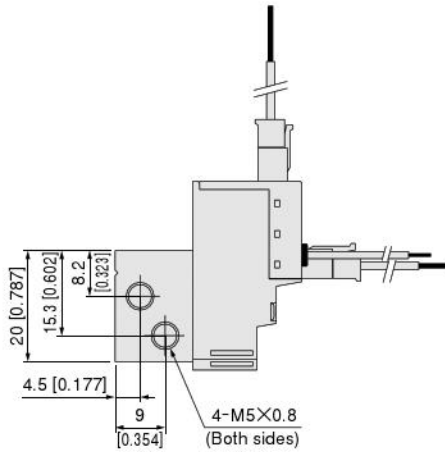

## Unit dimensions

Number of units	L	P	Number of units	L	P
2	34.2 [1.346]	27.2 [1.071]	12	136.2 [5.362]	129.2 [5.087]
3	44.4 [1.748]	37.4 [1.472]	13	146.4 [5.764]	139.4 [5.488]
4	54.6 [2.150]	47.6 [1.874]	14	156.6 [6.165]	149.6 [5.890]
5	64.8 [2.551]	57.8 [2.276]	15	166.8 [6.567]	159.8 [6.291]
6	75 [2.953]	68 [2.677]	16	177 [6.969]	170 [6.693]
7	85.2 [3.354]	78.2 [3.079]	17	187.2 [7.370]	180.2 [7.094]
8	95.4 [3.756]	88.4 [3.480]	18	197.4 [7.772]	190.4 [7.496]
9	105.6 [4.157]	98.6 [3.882]	19	207.6 [8.173]	200.6 [7.898]
10	115.8 [4.559]	108.8 [4.283]	20	217.8 [8.575]	210.8 [8.299]
11	126 [4.961]	119 [4.685]	—	—	—

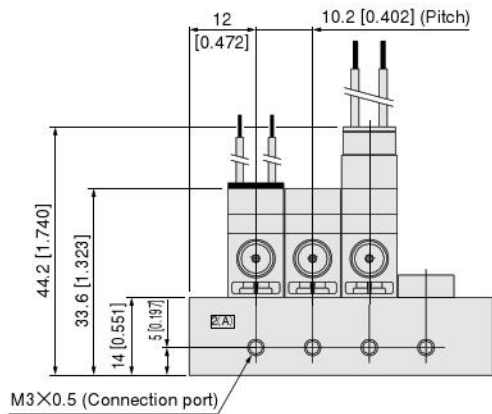

CS-G010M□A (1(P), 3(R) port: M5×0.8)

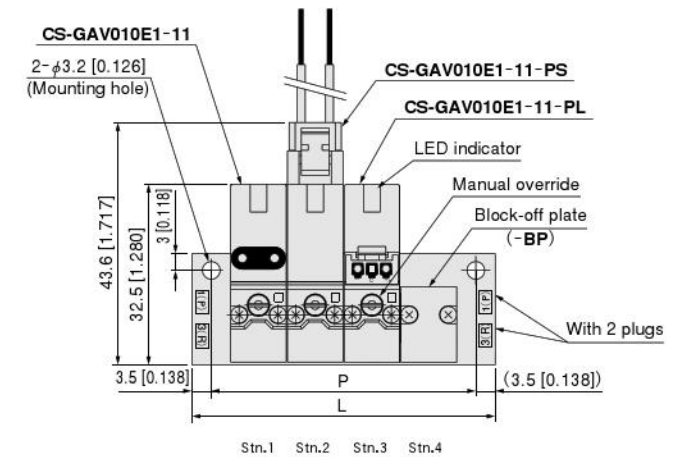
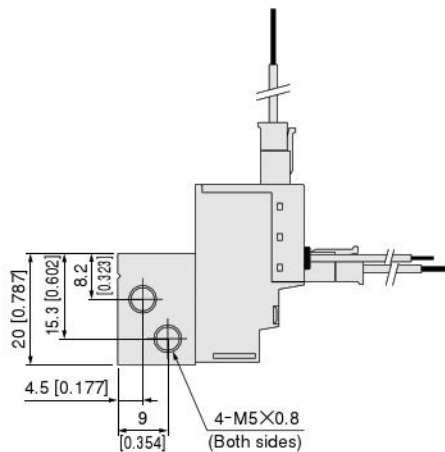

## Unit dimensions

Number of units	L	P	Number of units	L	P
2	34.2 [1.346]	27.2 [1.071]	12	136.2 [5.362]	129.2 [5.087]
3	44.4 [1.748]	37.4 [1.472]	13	146.4 [5.764]	139.4 [5.488]
4	54.6 [2.150]	47.6 [1.874]	14	156.6 [6.165]	149.6 [5.890]
5	64.8 [2.551]	57.8 [2.276]	15	166.8 [6.567]	159.8 [6.291]
6	75 [2.953]	68 [2.677]	16	177 [6.969]	170 [6.693]
7	85.2 [3.354]	78.2 [3.079]	17	187.2 [7.370]	180.2 [7.094]
8	95.4 [3.756]	88.4 [3.480]	18	197.4 [7.772]	190.4 [7.496]
9	105.6 [4.157]	98.6 [3.882]	19	207.6 [8.173]	200.6 [7.898]
10	115.8 [4.559]	108.8 [4.283]	20	217.8 [8.575]	210.8 [8.299]
11	126 [4.961]	119 [4.685]	—	—	—

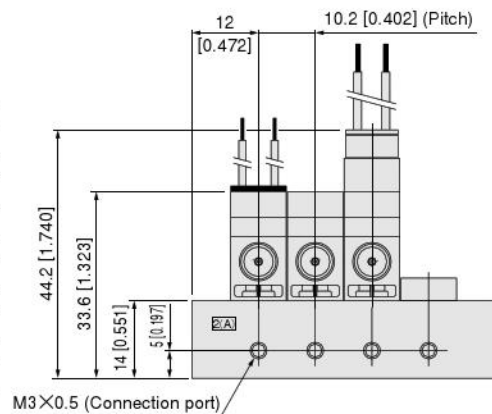

For optional wiring, see p.132.

**Dimensions of A Type Manifold (for Manifold Piping with Positive Pressure Solenoid Valves) mm [in.]**

**CS-G010MH□A (1(P), 3(R) port: Rc1/8)**

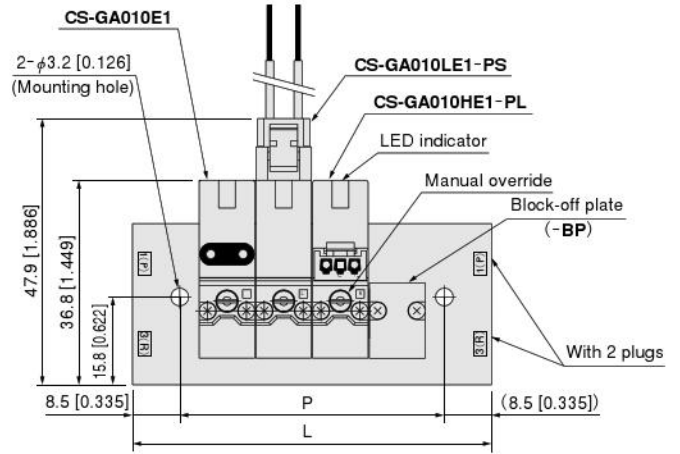
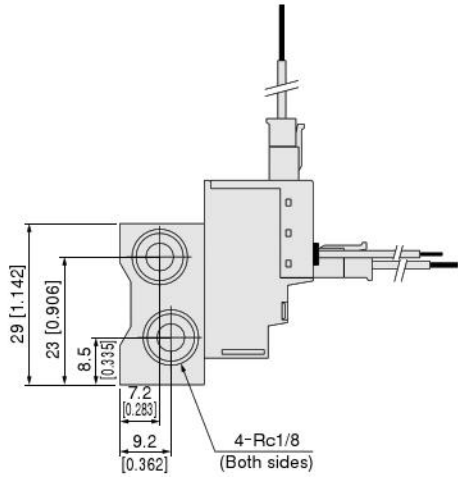

**Unit dimensions**

Number of units	L	P	Number of units	L	P
2	44.2 [1.740]	27.2 [1.071]	12	146.2 [5.756]	129.2 [5.087]
3	54.4 [2.142]	37.4 [1.472]	13	156.4 [6.157]	139.4 [5.488]
4	64.6 [2.543]	47.6 [1.874]	14	166.6 [6.559]	149.6 [5.890]
5	74.8 [2.945]	57.8 [2.276]	15	176.8 [6.961]	159.8 [6.291]
6	85 [3.346]	68 [2.677]	16	187 [7.362]	170 [6.693]
7	95.2 [3.748]	78.2 [3.079]	17	197.2 [7.764]	180.2 [7.094]
8	105.4 [4.150]	88.4 [3.480]	18	207.4 [8.165]	190.4 [7.496]
9	115.6 [4.551]	98.6 [3.882]	19	217.6 [8.567]	200.6 [7.898]
10	125.8 [4.953]	108.8 [4.283]	20	227.8 [8.969]	210.8 [8.299]
11	136 [5.354]	119 [4.685]	—	—	—

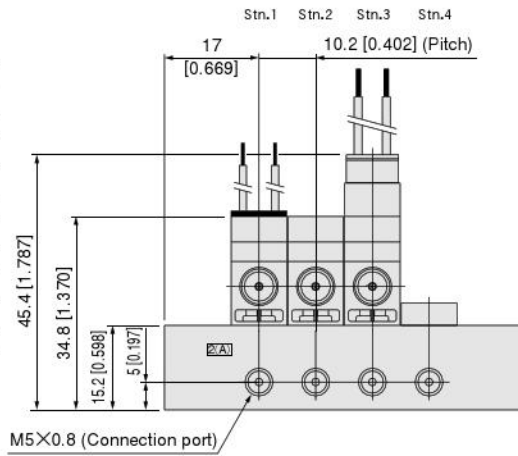

**CS-G010MH□A (1(P), 3(R) port: Rc1/8)**

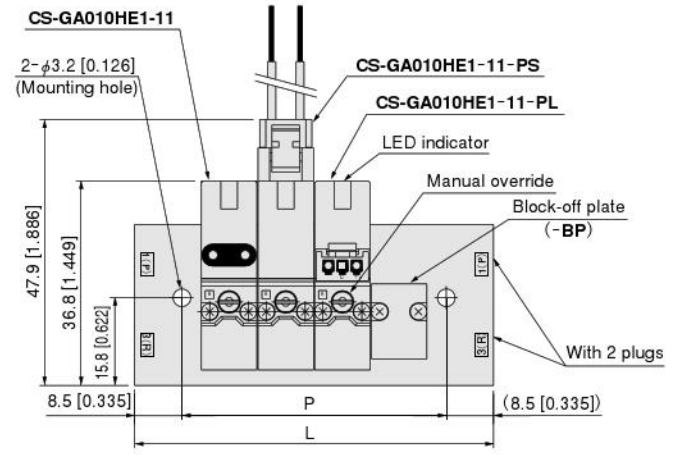
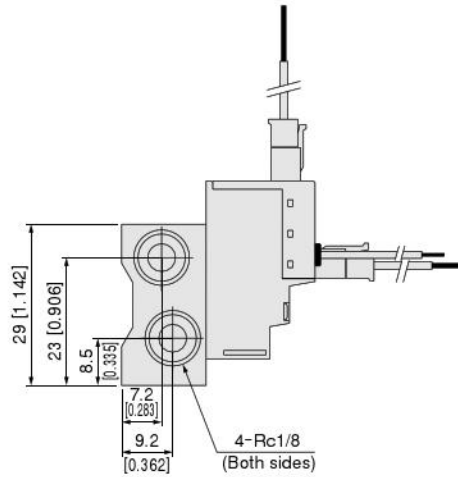

**Unit dimensions**

Number of units	L	P	Number of units	L	P
2	44.2 [1.740]	27.2 [1.071]	12	146.2 [5.756]	129.2 [5.087]
3	54.4 [2.142]	37.4 [1.472]	13	156.4 [6.157]	139.4 [5.488]
4	64.6 [2.543]	47.6 [1.874]	14	166.6 [6.559]	149.6 [5.890]
5	74.8 [2.945]	57.8 [2.276]	15	176.8 [6.961]	159.8 [6.291]
6	85 [3.346]	68 [2.677]	16	187 [7.362]	170 [6.693]
7	95.2 [3.748]	78.2 [3.079]	17	197.2 [7.764]	180.2 [7.094]
8	105.4 [4.150]	88.4 [3.480]	18	207.4 [8.165]	190.4 [7.496]
9	115.6 [4.551]	98.6 [3.882]	19	217.6 [8.567]	200.6 [7.898]
10	125.8 [4.953]	108.8 [4.283]	20	227.8 [8.969]	210.8 [8.299]
11	136 [5.354]	119 [4.685]	—	—	—

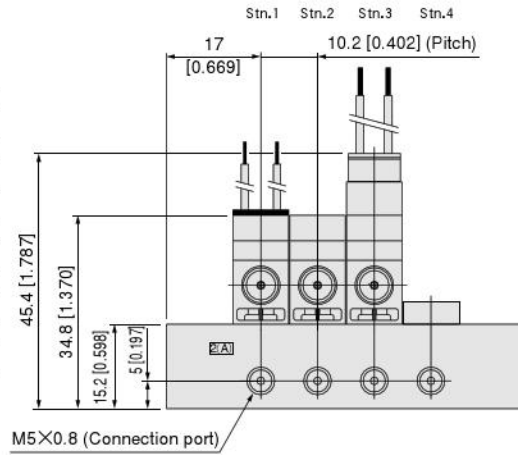

For optional wiring, see p.132.

**Dimensions of A Type Manifold (for Manifold Piping with Vacuum Solenoid Valves) mm [in.]**

**CS-G010MH□A (1(P), 3(R) port: Rc1/8)**

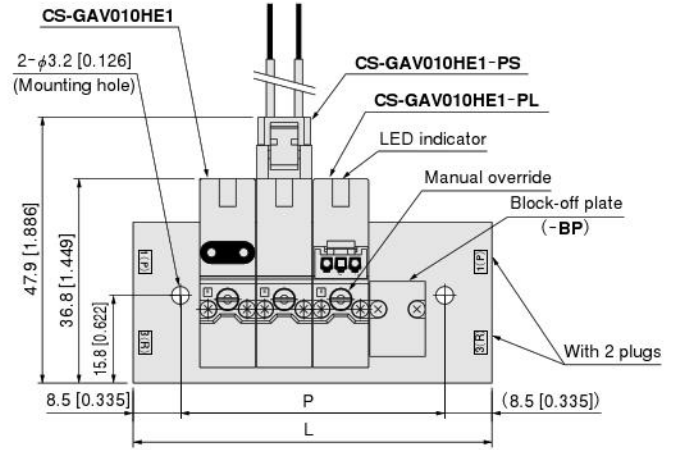
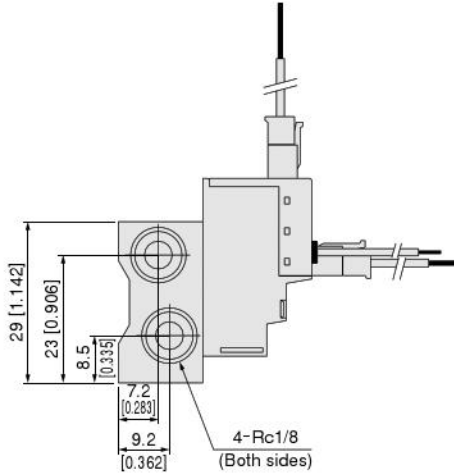

**Unit dimensions**

Number of units	L	P	Number of units	L	P
2	44.2 [1.740]	27.2 [1.071]	12	146.2 [5.756]	129.2 [5.087]
3	54.4 [2.142]	37.4 [1.472]	13	156.4 [6.157]	139.4 [5.488]
4	64.6 [2.543]	47.6 [1.874]	14	166.6 [6.559]	149.6 [5.890]
5	74.8 [2.945]	57.8 [2.276]	15	176.8 [6.961]	159.8 [6.291]
6	85 [3.346]	68 [2.677]	16	187 [7.362]	170 [6.693]
7	95.2 [3.748]	78.2 [3.079]	17	197.2 [7.764]	180.2 [7.094]
8	105.4 [4.150]	88.4 [3.480]	18	207.4 [8.165]	190.4 [7.496]
9	115.6 [4.551]	98.6 [3.882]	19	217.6 [8.567]	200.6 [7.898]
10	125.8 [4.953]	108.8 [4.283]	20	227.8 [8.969]	210.8 [8.299]
11	136 [5.354]	119 [4.685]	—	—	—

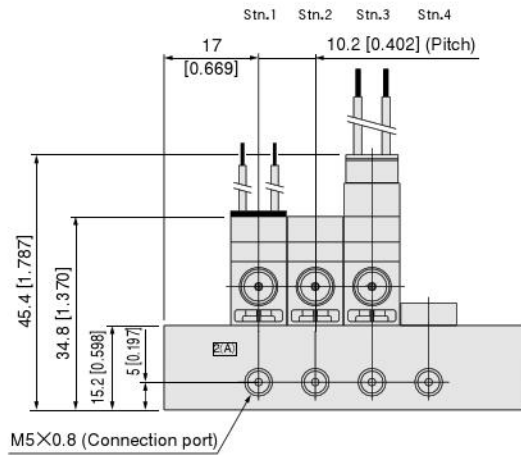

**CS-G010MH□A (1(P), 3(R) port: Rc1/8)**

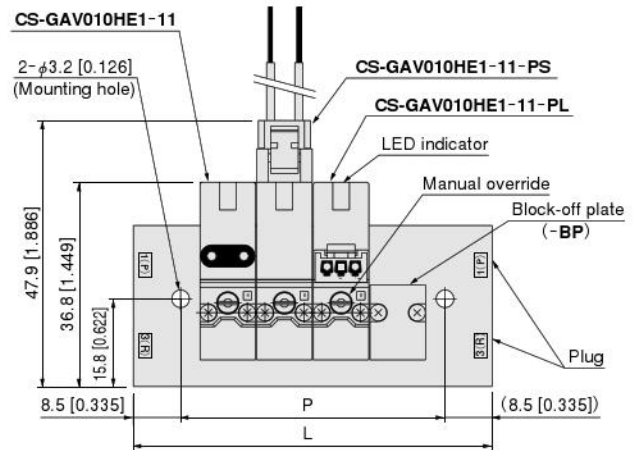
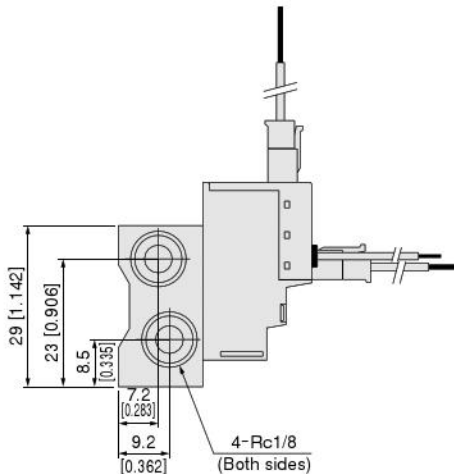

**Unit dimensions**

Number of units	L	P	Number of units	L	P
2	44.2 [1.740]	27.2 [1.071]	12	146.2 [5.756]	129.2 [5.087]
3	54.4 [2.142]	37.4 [1.472]	13	156.4 [6.157]	139.4 [5.488]
4	64.6 [2.543]	47.6 [1.874]	14	166.6 [6.559]	149.6 [5.890]
5	74.8 [2.945]	57.8 [2.276]	15	176.8 [6.961]	159.8 [6.291]
6	85 [3.346]	68 [2.677]	16	187 [7.362]	170 [6.693]
7	95.2 [3.748]	78.2 [3.079]	17	197.2 [7.764]	180.2 [7.094]
8	105.4 [4.150]	88.4 [3.480]	18	207.4 [8.165]	190.4 [7.496]
9	115.6 [4.551]	98.6 [3.882]	19	217.6 [8.567]	200.6 [7.898]
10	125.8 [4.953]	108.8 [4.283]	20	227.8 [8.969]	210.8 [8.299]
11	136 [5.354]	119 [4.685]	—	—	—

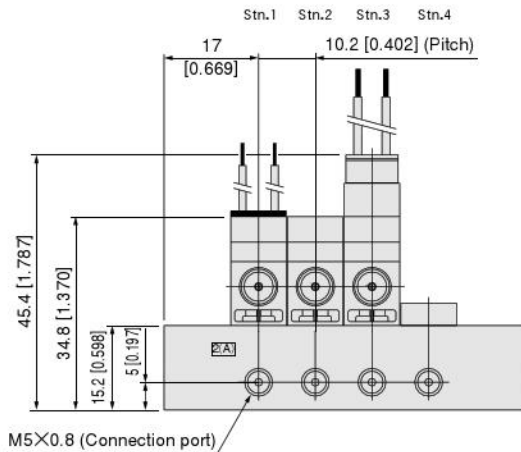

For optional wiring, see p.132.