

Koganei Clean System products provide complete support for the maintenance of a clean environment inside the cleanroom.

Koganei Clean System products meet the needs of the ultra-clean production environment. In everything from actuators and valves to air preparation and auxiliary equipment, anti-corrosion materials processing and other Koganei-developed design concepts serve to prevent particle contamination within the cleanroom. These perfectly designed mechanisms, which resolve even the slightest leaks to the outside during operations, have already won a high level of reliability.

Koganei Cleanliness

There is currently no standard in JIS or elsewhere for methods of evaluating cleanliness for pneumatic equipment in the cleanroom specifications. Therefore, to measure the effects of cleanroom contamination by pneumatic equipment, Koganei has decided to use "number of particles generated per 10 operations," rather than particle density. Koganei has also developed classifications for application classes in cleanroom, based on JIS and other upper limit density tables, and on the company's own experience.



- Remarks:
1. In the above table, product performance in terms of the number of particles generated per 10 operations is expressed as the upper limit of particles corresponding to the equivalent JIS or ISO class.
 2. In the above table, values in the JIS, ISO, and FED-STD upper limit density tables are calculated as upper density per liter.
 3. The classes shown are clean levels as classified in JIS and ISO.

From the above definitions, the Koganei clean level classes can be viewed as the level of average contamination per liter of surrounding air over a period of 10 operations in cleanroom. Air ventilation in cleanrooms is usually faster than 1 cycle per minute, and clean volumetric capacity is usually larger than 1 liter, which should provide a sufficient safety margin in practice.

Caution: The above conclusions are based on an ideal situation in which air ventilation is being implemented. For specific cases where air ventilation is not ensured, caution is needed since the clean classes cannot be maintained.

The clean system diagrams shown here are for Class 5 equivalent products. For Class 4 or Class 3 equivalent products, consult us.

Evaluations of Cleanliness

Koganei has therefore specified its in-house measurement methods, to conduct evaluations on the cleanroom rating.

The number of particles of the Air Cylinder Cleanroom Specification is measured as shown in the method below.

1. Measurement conditions

1-1 Test circuit: Figure 1 (no suction), Figure 2 (with suction)

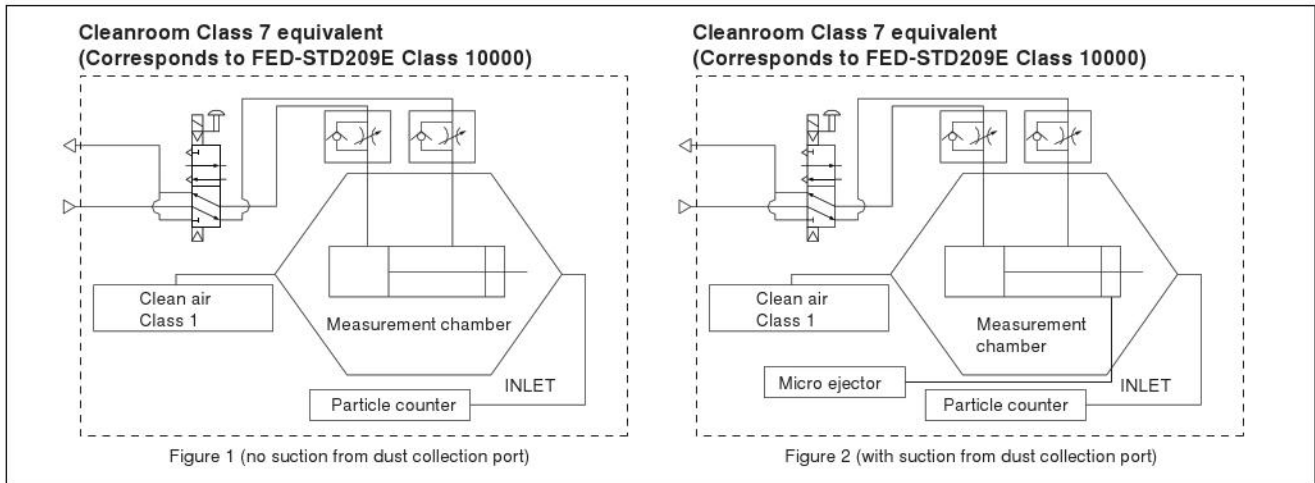

1-2 Operating conditions of tested cylinder

Operating frequency: 1Hz

Average speed: 500mm/s [20in./sec.]

Applied pressure: 0.5MPa [73psi.]

Suction condition: Microejector ME05, Primary side: 0.5MPa [73psi.] applied, Tube: $\phi 6$ [0.236in.]

Mounting direction: Vertical

Chamber volume: 8.3 ℓ [0.293ft³]

2. Particle counter

Manufacturer/model: RION/KM20

Suction flow rate: 28.3 ℓ /min [1ft³/min.]

Particle diameter: 0.1 μm , 0.2 μm , 0.3 μm , 0.5 μm , 0.7 μm , 1.0 μm

3. Measurement method

3-1 Confirmation of number of particles in the measurement system

Under the conditions in the above 1 and 2, using a particle counter to measure the sample for 9 minutes without operating the measurement sample, and confirmed the measured number of particle is 1 piece or less.

3-2 Measurement under operation

Under the conditions in the above 1 and 2, operating the measurement sample for 36 minutes, and measured the total values in the latter half of 18 minutes test.

3-3 Reconfirmation

Performed the measurement in 3-1 again, to reconfirm the number of particles in the measurement system.

4. Measurement results

● Cleanroom specification

Jig Cylinder (no suction from dust collection port)

Particle generation over 1 million operations (CS-CDA16 \times 30)

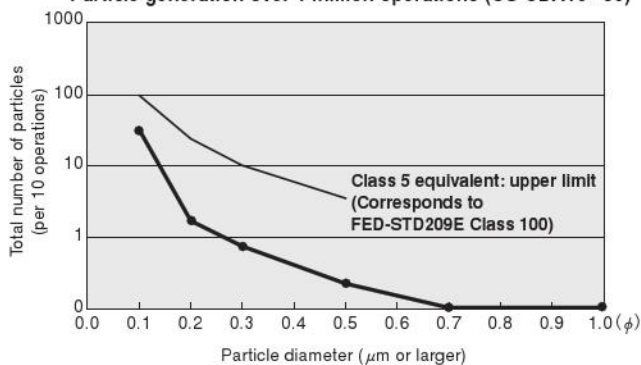

● Cleanroom specification

Slim Cylinder (with suction from dust collection port)

Particle generation over 1 million operations (CS-DA20 \times 100)

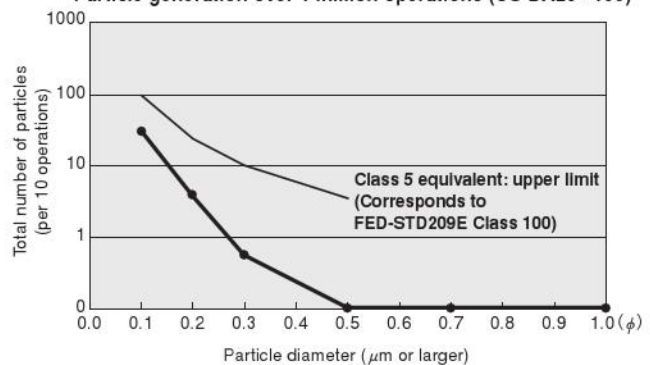

For "safety precautions" listed in the Clean System Product Drawings, see the materials below.

- For actuators, see "Safety Precautions" on p. 45 of the Actuators General Catalog .
- For valves, see "Safety Precautions" on p. 31 of the Valves General Catalog.
- For air treatment and auxiliary equipment, see "Safety Precautions" on p.31 of the General Catalog of Air Treatment, Auxiliary, Vacuum.

KOGANEI CLEAN SYSTEM SOLENOID VALVES F18 SERIES

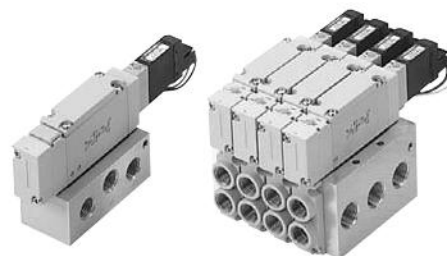

Symbols

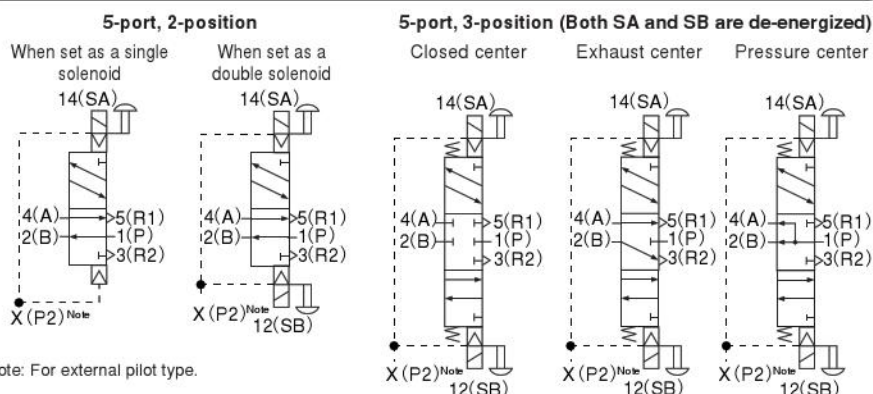

Specifications

Item	Basic model	CS-F18T1	CS-F18T3 CS-F18T4 CS-F18T5	CS-F18T1G	CS-F18T3G CS-F18T4G CS-F18T5G	CS-F18T1V	CS-F18T3V CS-F18T4V CS-F18T5V
	Media		Air				
Operation type		Internal pilot type		External pilot type (for positive pressure)		External pilot type (for vacuum)	
Effective area [CV]	mm ²	18 [1]					
Port size		Fitting for ϕ 8 and ϕ 10, Rc1/4		M5 X 0.8, Fitting for ϕ 8 and ϕ 10, Rc1/4			
Lubrication		Not required					
Operating pressure range	Main valve	0.15~0.7MPa [22~102psi.]		0~0.7MPa [0~102psi.] ^{Note1}		-100kPa~0.15MPa [-29.53in.Hg~22psi.]	
	External pilot	—		0.2~0.7MPa [29~102psi.] ^{Note1}		0.2~0.7MPa [29~102psi.]	
Proof pressure	MPa [psi.]	1.05 [152]					
Response time ^{Note2}	DC12V, DC24V	25/35 or below	15/70 or below	25/35 or below	15/70 or below	25/35 or below	15/70 or below
	AC100V	25/35 or below	15/70 or below	25/35 or below	15/70 or below	25/35 or below	15/70 or below
ON/OFF time	ms	25/35 or below	15/70 or below	25/35 or below	15/70 or below	25/35 or below	15/70 or below
Maximum operating frequency	Hz	5					
Minimum time to energize for self holding ^{Note3}	ms	50	—	50	—	50	—
Operating temperature range (atmosphere and media)	°C [°F]	5~50 [41~122]					
Shock resistance	m/s ² [G]	1373 {140.0} (Axial direction 294.2 {30.0})	294.2 {30.0}	1373 {140.0} (Axial direction 294.2 {30.0})	294.2 {30.0}	1373 {140.0} (Axial direction 294.2 {30.0})	294.2 {30.0}
Mounting direction		Any					

Notes: 1. When the main valve pressure is 0.2~0.7MPa [29~102psi.], set the external pilot pressure to the main valve pressure or higher, and to 0.7MPa [102psi.] or less.

2. Values when air pressure is 0.5MPa [73psi.]. The values for 2-position valves are when used as a single solenoid, and the values for 3-position valves are those when switching from the neutral position of closed center.

3. When used as a double solenoid valve.

Solenoid Specifications

Item	Rated voltage	DC12V	DC24V	AC100V	
	Voltage range	V	10.8~13.2 (12±10%)	21.6~26.4 (24±10%)	90~110 (100±10%)
Rated frequency	Hz	—	—	50	60
Current (when rated voltage is applied)	mA (r.m.s)	—	—	15 ^{Note1}	15 ^{Note1}
	Starting	—	—	15 ^{Note1}	15 ^{Note1}
	Energizing	76	38	15 ^{Note1}	15 ^{Note1}
Power consumption	W	0.9	0.9	1.5VA	
Allowable leakage current	mA	4.0	2.0	4.0	
Insulation resistance ^{Note2}	MΩ	Over 10			
Color of LED indicator		14(SA) : Red, 12(SB) : Green	14(SA) : Red, 12(SB) : Green	14(SA) : Red, 12(SB) : Green	
Surge suppression (as standard)		Flywheel diode		Bridge diode	

Notes: 1. Since the AC types have built-in bridge diodes, the starting current and energizing current value are virtually the same.

2. Value at DC500V megger.

Inner Construction and Major Parts

● CS-F18T1-A1

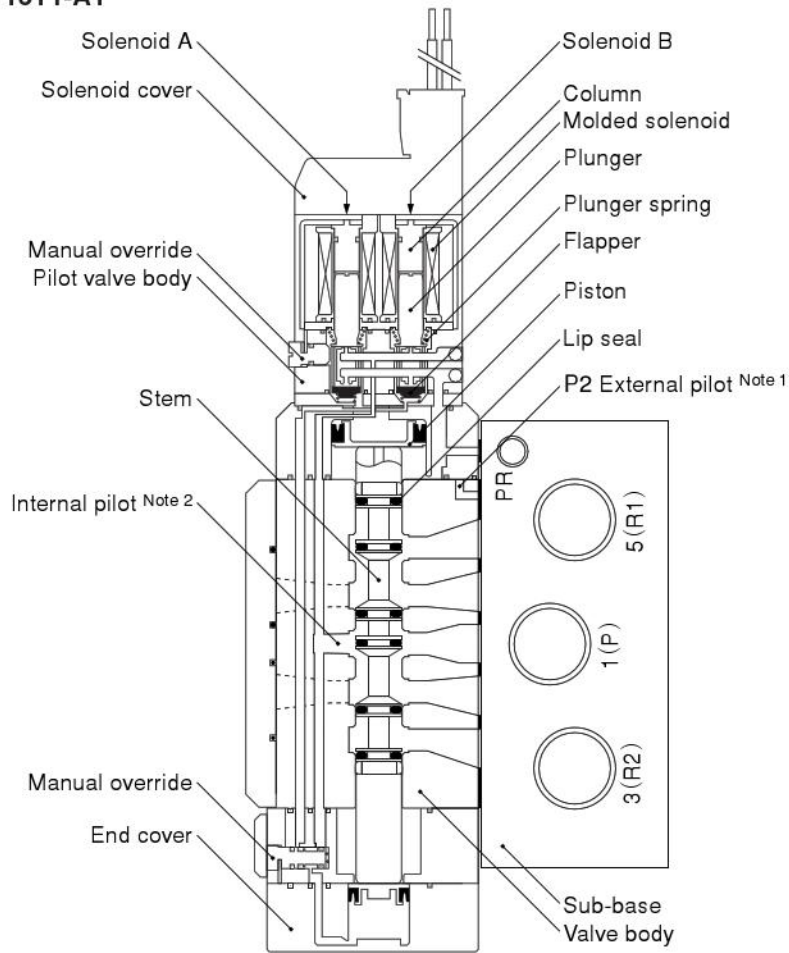

Major Parts and Materials

Parts		Materials
Valve	Body	Aluminum die-casting
	Stem	Aluminum alloy
	Lip seal	Synthetic rubber
	Flapper	
	Sub-base	Aluminum alloy (anodized)
	Plunger	Magnetic stainless steel
	Column	
End cover	Plastic	
Manifold	Body	Aluminum alloy (anodized)
	Monoblock	
	Block-off plate	Mild steel (nickel plated)
	Seal	Synthetic rubber

Notes: 1. For external pilot type
 2. Not available with external pilot type

Order Codes

CS-F18 - <input type="text"/> - <input type="text"/> - <input type="text"/> - <input type="text"/> - <input type="text"/>													
Clean system F18 series valve basic model		Pilot specification			Manual override		Valve outlet type ^{Note 3}						
		Internal pilot	External pilot (positive pressure)	External pilot (vacuum)	Manual override button	Manual override lever (made to order) ^{Note 1}	Without inlet/outlet block	With A type outlet plate	With A type sub-base	With outlet port fitting block	With outlet port female thread block		
<ul style="list-style-type: none"> ● For sub-base-mounted units (cannot be used for units without sub-base) ● For A type manifold ● For F type manifold 	CS-F18T1	2-position (Both single and double solenoid use)		Blank	G	V	Blank	-R ^{Note 1}	Blank ^{Note 2}	-A1 ^{Note 2}	-A2	-FJ ^{Note 2}	-FM ^{Note 2}
	CS-F18T3	3-position (Closed center)											
	CS-F18T4	3-position (Exhaust center)											
	CS-F18T5	3-position (Pressure center)											

Notes: 1. The manual override lever is made to order. Consult us for delivery. When the valve specification is T1, the manual override lever is available for the A side only.
 2. Two manifold mounting screws are included.
 3. For the outlet port size, see the table at right.

Monoblock Manifold A type (Base Piping Type) Order Codes

CS-F18M <input type="text"/> <input type="text"/> <input type="text"/> <input type="text"/> <input type="text"/> <input type="text"/> <input type="text"/> <input type="text"/> <input type="text"/> <input type="text"/>											
Clean system F18 series manifold basic model	Number of units	A	Manifold outlet specification		Pilot specification		Station ^{Note 1}		Valve size	Valve specification	Pilot specification
	2 : 2 units 3 : 3 units ⋮ 20 : 20 units		With fitting block: φ 8, φ 10	With female thread block: Rc1/4	Internal pilot	External pilot	stn.1 : First stn.2 : Second stn.3 : Third ⋮ stn.20 : 20th	CS-F18	T1: 2-position, single solenoid specification T2: 2-position, double solenoid specification ^{Note 2} T3: 3-position, closed center T4: 3-position, exhaust center T5: 3-position, pressure center	Blank G V	
CS-F18M			J	M	Blank	G					

Notes: 1. Valve mounting location is from the left, with the solenoid on top and the valve in front.
 2. This is a special model when ordering manifolds. If ordering valves only for repairs, etc., order CS-F□T1, and switch to the double solenoid specification for use.
 3. The manual override lever is made to order. Consult us for delivery. When the valve specification is T1 or T2, the manual override lever is available for the A side only.
 4. Always enter -A1.

Monoblock Manifold F type (Direct Piping Type) Order Codes

CS-F18M <input type="text"/> <input type="text"/> <input type="text"/> <input type="text"/> <input type="text"/> <input type="text"/> <input type="text"/> <input type="text"/>									
Clean system F18 series manifold basic model	Number of units	F	Station ^{Note 1}		Valve size	Valve specification	Manual override	Valve outlet type	
	2 : 2 units 3 : 3 units ⋮ 20 : 20 units		stn.1 : First stn.2 : Second stn.3 : Third ⋮ stn.20 : 20th	CS-F18	T1: 2-position, single solenoid specification T2: 2-position, double solenoid specification ^{Note 2} T3: 3-position, closed center T4: 3-position, exhaust center T5: 3-position, pressure center	Blank -R ^{Note 3}	With outlet port fitting block With outlet port female thread block		
CS-F18M								-FJ	-FM

Notes: 1. Valve mounting location is from the left, with the solenoid on top and the valve in front.
 2. This is a special model when ordering manifolds. If ordering valves only for repairs, etc., order CS-F□T1, and switch to the double solenoid specification for use.
 3. The manual override lever is made to order. Consult us for delivery. When the valve specification is T1 or T2, the manual override lever is available for the A side only.

Wiring specification						Voltage
L type plug connector			S type plug connector			
Without connector	Lead wire		Without connector	Lead wire		
	300mm [11.8in.]	3000mm [118in.]		300mm [11.8in.]	3000mm [118in.]	
Blank	-PL	-PL3	-PN	-PS	-PS3	DC24V DC12V AC100V

Valve outlet type (code)	Outlet port size
-A2	Rc1/4
-FJ	φ 8, φ 10
-FM	Rc1/4

Manual override	Valve outlet type	Wiring specification										Voltage
Blank -R ^{Note 3}	-A1 ^{Note 4}	L type connector					S type connector					
		Without connector	Lead wire		Pre-wired positive common terminal		Without connector	Lead wire		Pre-wired positive common terminal		
			300mm [11.8in.]	3000mm [118in.]	Lead wire 300mm [11.8in.]	Lead wire 3000mm [118in.]		300mm [11.8in.]	3000mm [118in.]	Lead wire 300mm [11.8in.]	Lead wire 3000mm [118in.]	
		Blank	-PL	-PL3	-CPL	-CPL3	-PN	-PS	-PS3	-CPS	-CPS3	DC24V DC12V AC100V

CS-F [Valve size] BP (for block-off plate)

Wiring specification										Voltage
L type connector					S type connector					
Without connector	Lead wire		Pre-wired positive common terminal		Without connector	Lead wire		Pre-wired positive common terminal		
	300mm [11.8in.]	3000mm [118in.]	Lead wire 300mm [11.8in.]	Lead wire 3000mm [118in.]		300mm [11.8in.]	3000mm [118in.]	Lead wire 300mm [11.8in.]	Lead wire 3000mm [118in.]	
Blank	-PL	-PL3	-CPL	-CPL3	-PN	-PS	-PS3	-CPS	-CPS3	DC24V DC12V AC100V

CS-F [Valve size] BP (for block-off plate)

Dimensions of Single Valve Unit mm [in.]

CS-F18T Valve specification Operation type -A2-PS

With an A type sub-base
S type plug connector

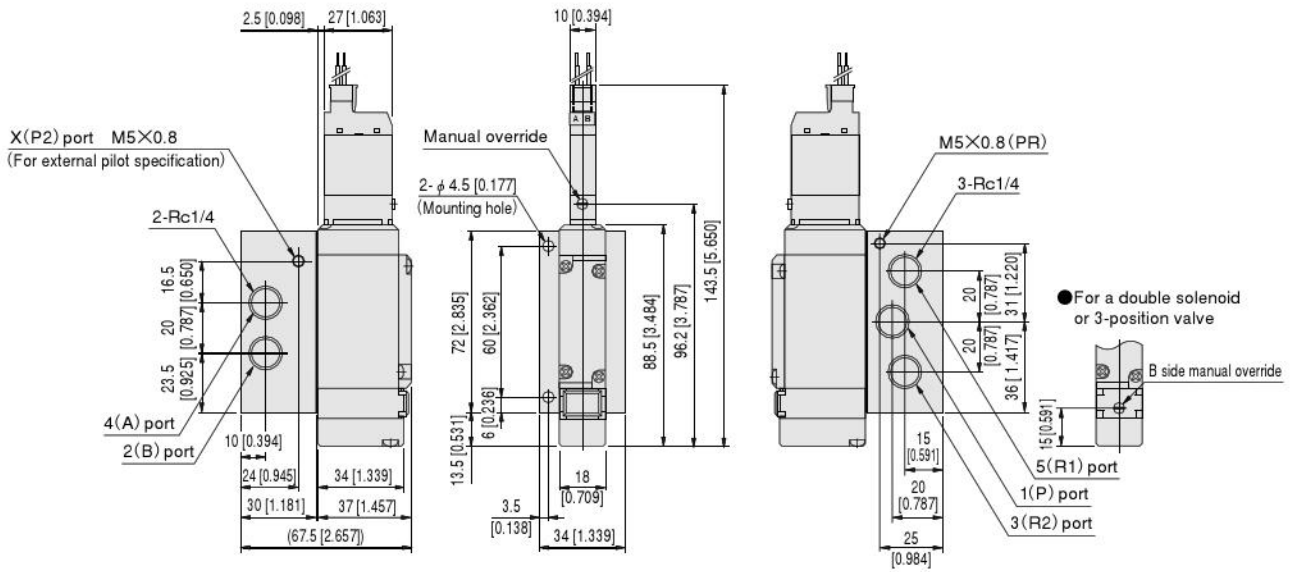

● Option

● L type plug connector: -PL

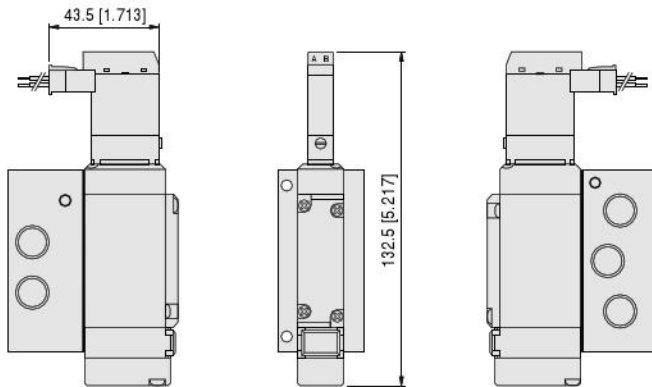

● Made to Order

● Manual override lever

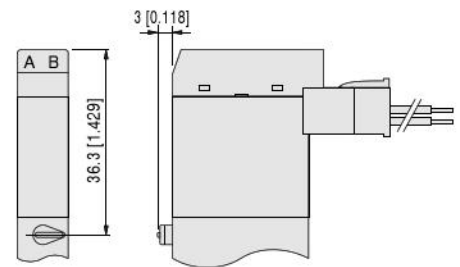

Dimensions of Monoblock Manifold A Type, F Type mm [in.]

CS-F18M Number of units A M Pilot specification (base piping type)

Monoblock manifold A type
Manifold with outlet port different size fitting blocks
S type plug connector

Internal pilot specification

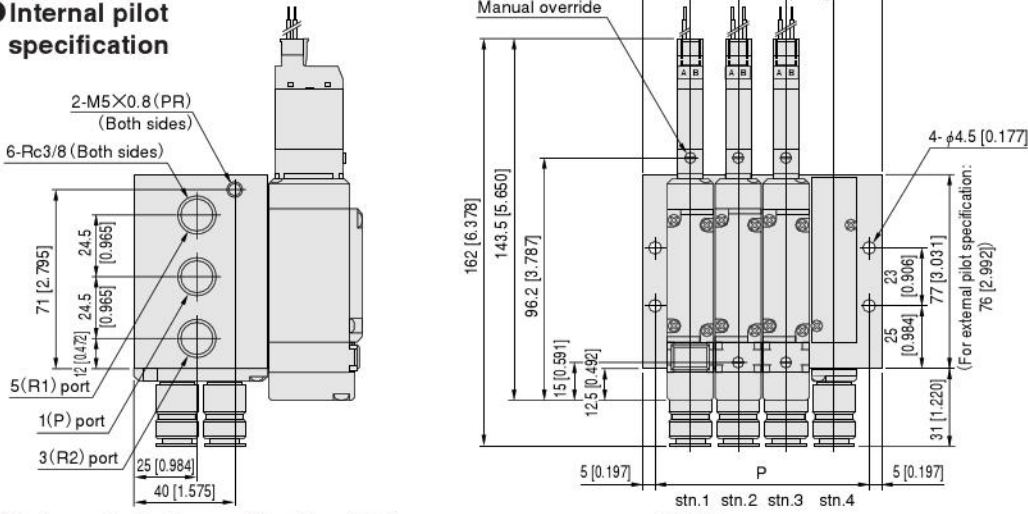

External pilot specification (Note)

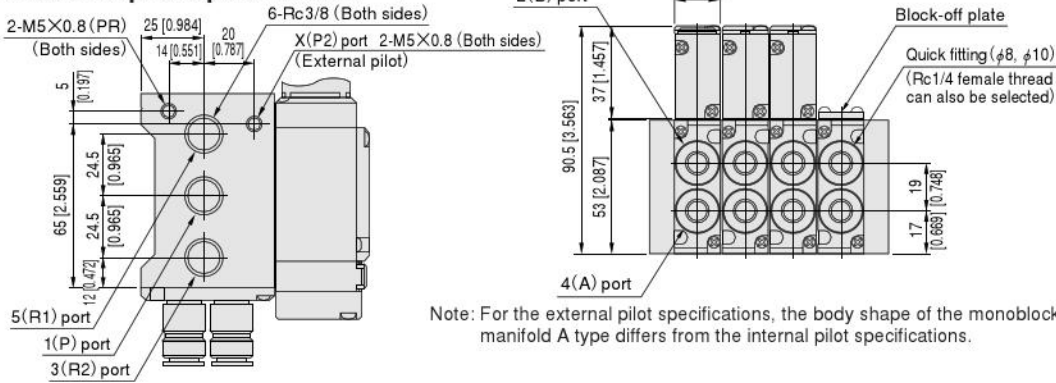

CS-F18M Number of units F (direct piping type)

Monoblock manifold F type
Valves with outlet port different size fitting blocks
S type plug connector

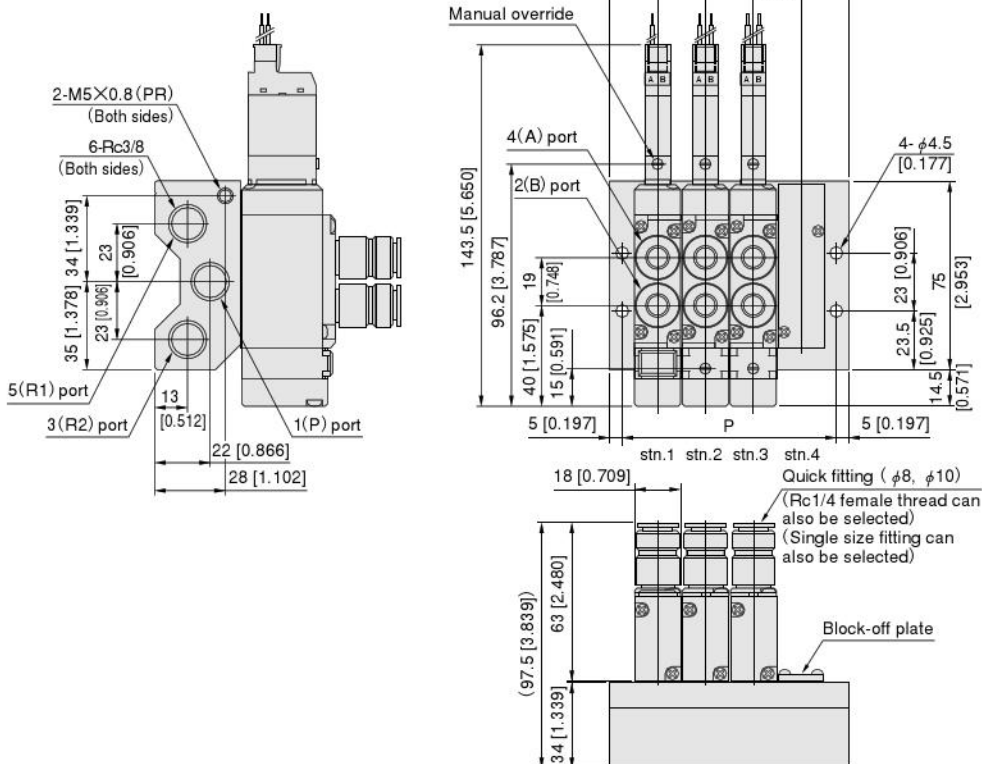

Unit dimensions

No. of units	L	P
2	57 [2.244]	47 [1.850]
3	76 [2.992]	66 [2.598]
4	95 [3.740]	85 [3.346]
5	114 [4.488]	104 [4.094]
6	133 [5.236]	123 [4.843]
7	152 [5.984]	142 [5.591]
8	171 [6.732]	161 [6.339]
9	190 [7.480]	180 [7.087]
10	209 [8.228]	199 [7.835]
11	228 [8.976]	218 [8.583]
12	247 [9.724]	237 [9.331]
13	266 [10.472]	256 [10.079]
14	285 [11.220]	275 [10.827]
15	304 [11.969]	294 [11.575]
16	323 [12.717]	313 [12.323]
17	342 [13.465]	332 [13.071]
18	361 [14.213]	351 [13.819]
19	380 [14.961]	370 [14.567]
20	399 [15.709]	389 [15.315]

Unit dimensions

No. of units	L	P
2	57 [2.244]	47 [1.850]
3	76 [2.992]	66 [2.598]
4	95 [3.740]	85 [3.346]
5	114 [4.488]	104 [4.094]
6	133 [5.236]	123 [4.843]
7	152 [5.984]	142 [5.591]
8	171 [6.732]	161 [6.339]
9	190 [7.480]	180 [7.087]
10	209 [8.228]	199 [7.835]
11	228 [8.976]	218 [8.583]
12	247 [9.724]	237 [9.331]
13	266 [10.472]	256 [10.079]
14	285 [11.220]	275 [10.827]
15	304 [11.969]	294 [11.575]
16	323 [12.717]	313 [12.323]
17	342 [13.465]	332 [13.071]
18	361 [14.213]	351 [13.819]
19	380 [14.961]	370 [14.567]
20	399 [15.709]	389 [15.315]