

Koganei Clean System products provide complete support for the maintenance of a clean environment inside the cleanroom.

Koganei Clean System products meet the needs of the ultra-clean production environment. In everything from actuators and valves to air preparation and auxiliary equipment, anti-corrosion materials processing and other Koganei-developed design concepts serve to prevent particle contamination within the cleanroom. These perfectly designed mechanisms, which resolve even the slightest leaks to the outside during operations, have already won a high level of reliability.

Koganei Cleanliness

There is currently no standard in JIS or elsewhere for methods of evaluating cleanliness for pneumatic equipment in the cleanroom specifications. Therefore, to measure the effects of cleanroom contamination by pneumatic equipment, Koganei has decided to use "number of particles generated per 10 operations," rather than particle density. Koganei has also developed classifications for application classes in cleanroom, based on JIS and other upper limit density tables, and on the company's own experience.

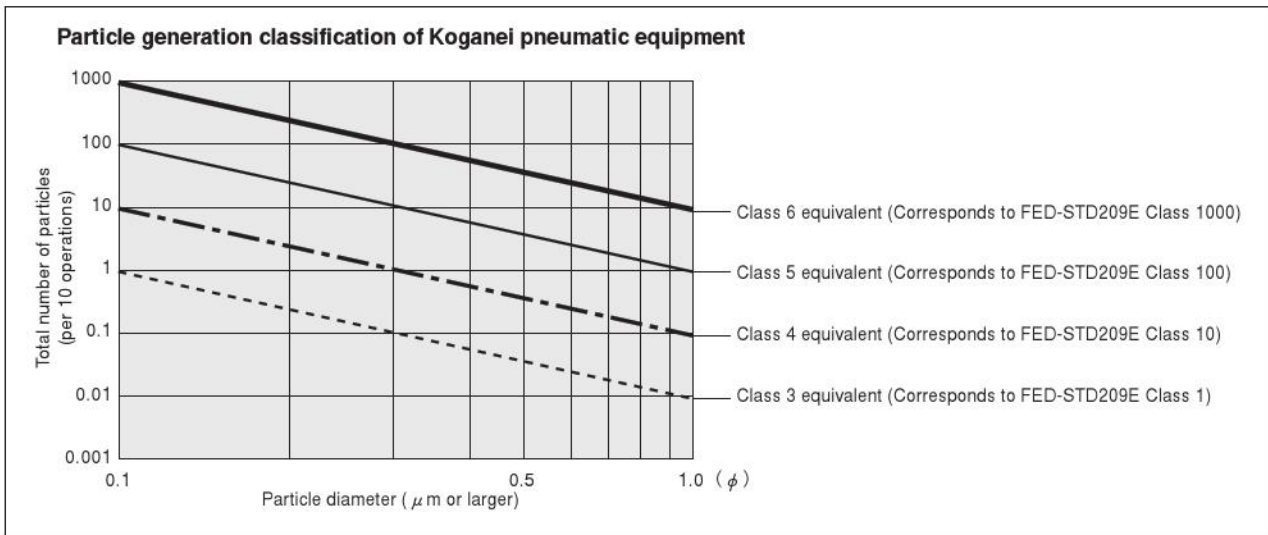

- Remarks:
1. In the above table, product performance in terms of the number of particles generated per 10 operations is expressed as the upper limit of particles corresponding to the equivalent JIS or ISO class.
 2. In the above table, values in the JIS, ISO, and FED-STD upper limit density tables are calculated as upper density per liter.
 3. The classes shown are clean levels as classified in JIS and ISO.

From the above definitions, the Koganei clean level classes can be viewed as the level of average contamination per liter of surrounding air over a period of 10 operations in cleanroom. Air ventilation in cleanrooms is usually faster than 1 cycle per minute, and clean volumetric capacity is usually larger than 1 liter, which should provide a sufficient safety margin in practice.

Caution: The above conclusions are based on an ideal situation in which air ventilation is being implemented. For specific cases where air ventilation is not ensured, caution is needed since the clean classes cannot be maintained.

The clean system diagrams shown here are for Class 5 equivalent products. For Class 4 or Class 3 equivalent products, consult us.

Evaluations of Cleanliness

Koganei has therefore specified its in-house measurement methods, to conduct evaluations on the cleanroom rating.

The number of particles of the Air Cylinder Cleanroom Specification is measured as shown in the method below.

1. Measurement conditions

1-1 Test circuit: Figure 1 (no suction), Figure 2 (with suction)

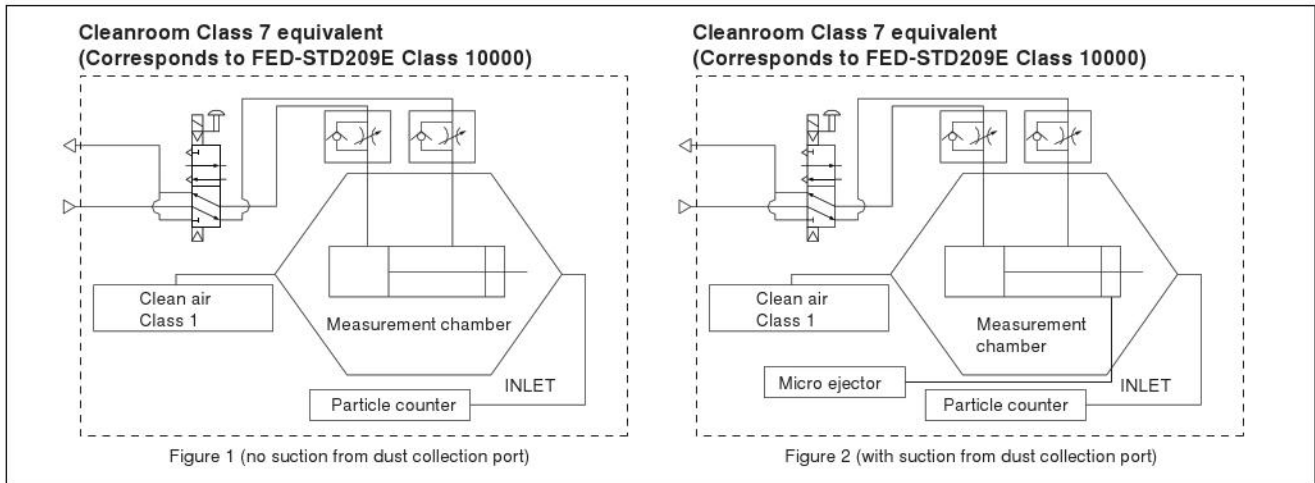

1-2 Operating conditions of tested cylinder

Operating frequency: 1Hz

Average speed: 500mm/s [20in./sec.]

Applied pressure: 0.5MPa [73psi.]

Suction condition: Microejector ME05, Primary side: 0.5MPa [73psi.] applied, Tube: $\phi 6$ [0.236in.]

Mounting direction: Vertical

Chamber volume: 8.3 ℓ [0.293ft³]

2. Particle counter

Manufacturer/model: RION/KM20

Suction flow rate: 28.3 ℓ /min [1ft³/min.]

Particle diameter: 0.1 μm , 0.2 μm , 0.3 μm , 0.5 μm , 0.7 μm , 1.0 μm

3. Measurement method

3-1 Confirmation of number of particles in the measurement system

Under the conditions in the above 1 and 2, using a particle counter to measure the sample for 9 minutes without operating the measurement sample, and confirmed the measured number of particle is 1 piece or less.

3-2 Measurement under operation

Under the conditions in the above 1 and 2, operating the measurement sample for 36 minutes, and measured the total values in the latter half of 18 minutes test.

3-3 Reconfirmation

Performed the measurement in 3-1 again, to reconfirm the number of particles in the measurement system.

4. Measurement results

● Cleanroom specification

Jig Cylinder (no suction from dust collection port)

Particle generation over 1 million operations (CS-CDA16 \times 30)

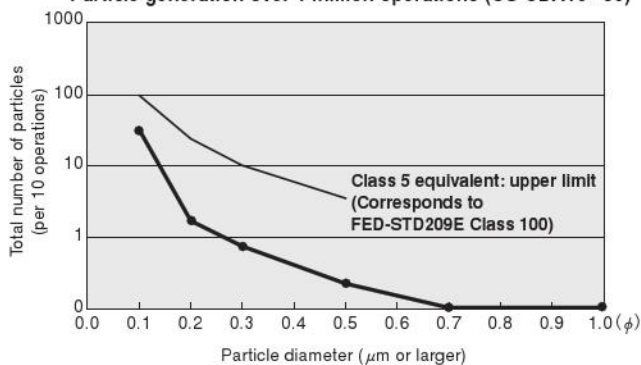

● Cleanroom specification

Slim Cylinder (with suction from dust collection port)

Particle generation over 1 million operations (CS-DA20 \times 100)

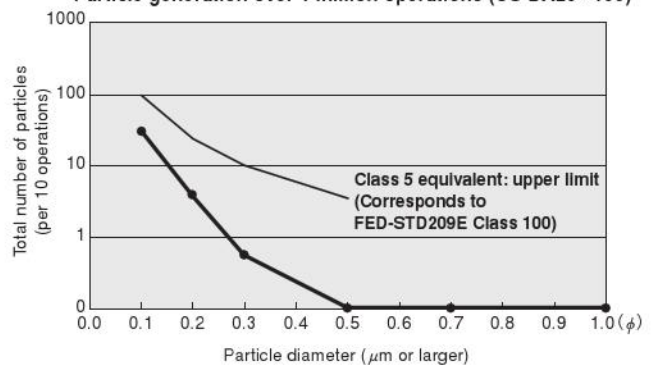

For "safety precautions" listed in the Clean System Product Drawings, see the materials below.

- For actuators, see "Safety Precautions" on p. 45 of the Actuators General Catalog .
- For valves, see "Safety Precautions" on p. 31 of the Valves General Catalog.
- For air treatment and auxiliary equipment, see "Safety Precautions" on p.31 of the General Catalog of Air Treatment, Auxiliary, Vacuum.

KOGANEI CLEAN SYSTEM SLIM CYLINDERS

Double Acting Type



Symbol

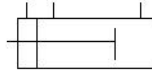

Specifications

Item	Bore size mm [in.]	φ 20~φ 40 [0.787~1.575]	φ 50, φ 63 [1.969, 2.480]
Operating type		Double acting type	
Media		Air	
Operating pressure range	MPa [psi.]	0.1~0.9 [15~131]	0.1~0.7 [15~102]
Proof pressure	MPa [psi.]	1.32 [191]	1.03 [149]
Operating temperature range	°C [°F]	0~60 [32~140]	
Operating speed range	mm/s [in./sec.]	50~300 [2.0~11.8]	
Cushion		Fixed type (Rubber bumper)	Variable type (15mm [0.591in.] stroke)
Lubrication		Not required	
Port size	Supply port	Rc1/8	Rc1/4
	Dust collection port	M5×0.8	

Bore Size and Stroke

Bore size	Mounting type	Standard strokes	Maximum stroke	Maximum available stroke
20 [0.787]	Foot mounting	25 50 75 100 125 150	200	1050 [41.3]
	Nose mounting			
	Flange mounting			
25 [0.984]	Foot mounting	25 50 75 100 125 150 200	250	
	Nose mounting			
	Flange mounting			
32 [1.260]	Foot mounting	25 50 75 100 125 150 200	300	
	Nose mounting			
	Flange mounting			
40 [1.575]	Foot mounting	25 50 75 100 125 150 200 250 300	400	
	Nose mounting			
	Flange mounting			
50 [1.969]	Foot mounting	25 50 75 100 150 200 250 300 350 400	500	
	Nose mounting			
	Flange mounting			
63 [2.480]	Foot mounting	25 50 75 100 150 200 250 300 350 400 500	600	900 [35.4]
	Nose mounting			
	Flange mounting			

Remarks: 1. Stroke tolerance ${}^+1_0^{+0.039}$
 2. For non-standard strokes, consult us.
 3. The minimum operating pressure when the stroke is over the maximum stroke at bore sizes of φ 20~φ 40 is 0.2MPa [29psi.].

Order Codes

CS — **DA** **20×50** — [] — [] — [] — [] — [] — []

Clean system product

Slim cylinder
Double acting type

Bore size
X
Stroke

Head cover type
Blank — Standard head
A — Short head

Mounting type
Blank — Nose mounting type
1 — Foot mounting type
3 — Flange mounting type

Rod end accessory
Blank — Without rod end accessory
Y — Y type knuckle (With pin)
I — I type knuckle

Lead wire length
A — 1000mm [39in.]
B — 3000mm [118in.]

Number of sensor switches
1 — With 1 sensor switch
2 — With 2 sensor switches
3 — With 3 sensor switches

Sensor switch
Blank — Without sensor switch
ZG530 — 2-lead wire Solid state type with indicator lamp DC10~28V
ZG553 — 3-lead wire Solid state type with indicator lamp DC4.5~28V
CS3M — 2-lead wire Reed switch type with indicator lamp DC10~30V, AC85~230V
CS4M — 2-lead wire Reed switch type with indicator lamp DC10~30V, AC85~115V
CS5M — 2-lead wire Reed switch type without indicator lamp DC3~30V, AC85~115V
CS2F — 2-lead wire Reed switch type with indicator lamp AC85~230V
CS3F — 2-lead wire Reed switch type with indicator lamp DC10~30V
CS4F — 2-lead wire Reed switch type with indicator lamp DC10~30V
CS5F — 2-lead wire Reed switch type without indicator lamp DC3~30V

● For the order codes of additional parts, see p. 64.
 ● For details of sensor switches, see p.111~121.

Inner Construction and Major Parts

● $\phi 20 \sim \phi 40$

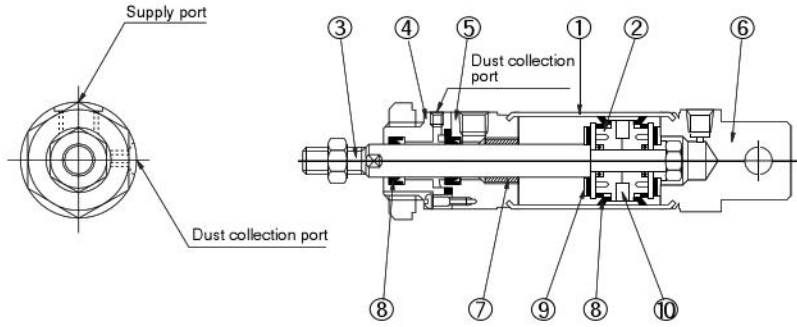

● $\phi 50, \phi 63$

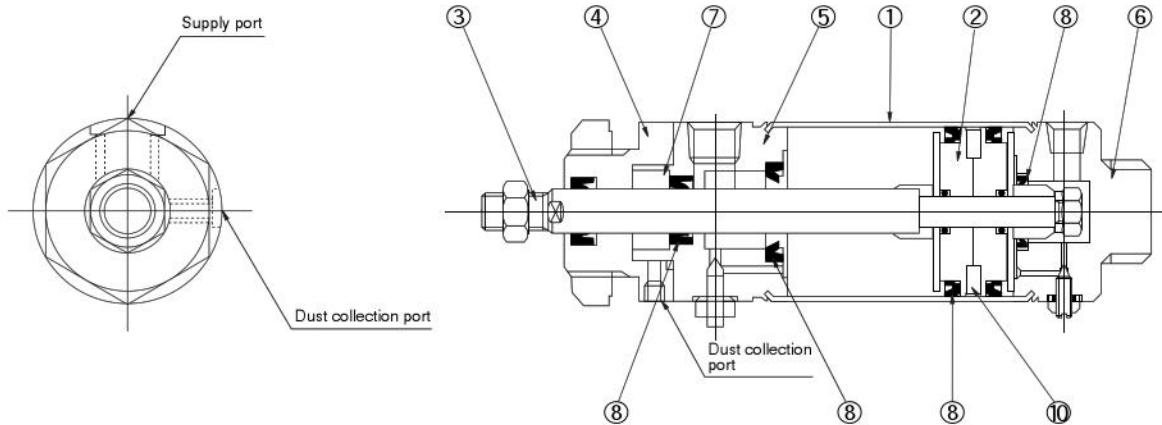

Major Parts and Materials

No.	Parts	Materials
①	Cylinder tube	Stainless steel
②	Piston	Plastic
③	Piston rod	Stainless steel
④	Dust prevention cover	Aluminum alloy (anodized)
⑤	Rod cover	
⑥	Head cover	
⑦	Rod bushing	Plastic
⑧	Seal	Synthetic rubber (NBR)
⑨	Bumper	
⑩	Magnet	Plastic magnet
	Mounting bracket	Mild steel (nickel plated)

Seals

● $\phi 20 \sim \phi 40$

Bore mm [in.]	Parts	Dust leak prevention seal and rod seal	Piston seal
	Quantity	1 each	2
20 [0.787]		NY-12×8×3.5	PPY-20
25 [0.984]		NY-14×10×3.5	PPY-25
32 [1.260]		NY-17×12×4	PPY-30
40 [1.575]		NY-22×16×5	PPY-40

● $\phi 50, \phi 63$

Bore mm [in.]	Parts	Dust leak prevention seal and rod seal	Piston seal	Cushion seal
	Quantity	1 each	2	2
50 [1.969]		NY-22×16×5	PGY-50	PCS-20
63 [2.480]		NY-22×16×5	PGY-63	PCS-20

Mass

● $\phi 20 \sim \phi 40$

Bore size mm [in.]	Zero stroke mass				Additional mass for each 1mm [0.0394 in.] stroke
	Nose type	Foot type	Flange type	Clevis type	
20 [0.787]	172 [6.07]	312 [11.01]	252 [8.89]	232 [8.18]	0.8 [0.028]
25 [0.984]	235 [8.29]	415 [14.64]	335 [11.82]	295 [10.41]	1.1 [0.039]
32 [1.260]	375 [13.23]	585 [20.63]	505 [17.81]	515 [18.17]	1.5 [0.053]
40 [1.575]	540 [19.05]	870 [30.69]	710 [25.04]	680 [23.99]	2.4 [0.085]

● $\phi 50, \phi 63$

Bore size mm [in.]	Zero stroke mass			Additional mass for each 1mm [0.0394 in.] stroke	Mass of mounting bracket	
	Standard head type	Short head type	Clevis head type		Foot bracket	Flange bracket
50 [1.969]	933 [32.91]	883 [31.15]	880 [31.04]	2.8 [0.099]	550 [19.40]	280 [9.88]
63 [2.480]	1265 [44.62]	1225 [43.21]	1195 [42.15]	3.5 [0.123]	730 [25.75]	370 [13.05]

Dimensions of Foot Mounting Type mm [in.]

● $\phi 20 \sim \phi 40$ CS-DA Bore size X Stroke -1

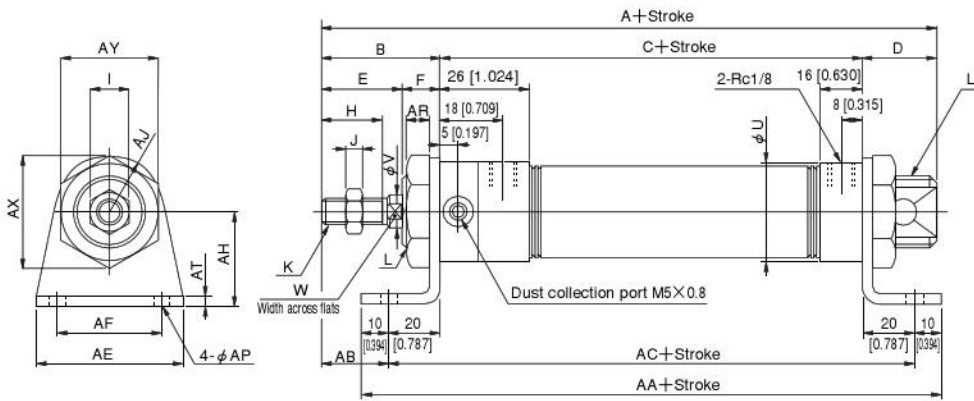

Bore Code	A	B	C	D	E	F	H	I	J	K	L	U	V	W
20 [0.787]	142 [5.591]	35 [1.378]	86 [3.386]	21 [0.827]	23 [0.906]	12 [0.472]	15 [0.591]	12 [0.472]	5 [0.197]	M8 X 1	M20 X 1.5	27 [1.063]	8 [0.315]	6 [0.236]
25 [0.984]	147 [5.787]	40 [1.575]	86 [3.386]	21 [0.827]	26 [1.024]	14 [0.551]	18 [0.709]	14 [0.551]	6 [0.236]	M10 X 1.25	M22 X 1.5	29 [1.142]	10 [0.394]	8 [0.315]
32 [1.260]	158 [6.220]	45 [1.772]	86 [3.386]	27 [1.063]	31 [1.220]	14 [0.551]	23 [0.906]	14 [0.551]	6 [0.236]	M10 X 1.25	M27 X 2	35 [1.378]	12 [0.472]	10 [0.394]
40 [1.575]	158 [6.220]	45 [1.772]	86 [3.386]	27 [1.063]	31 [1.220]	14 [0.551]	23 [0.906]	19 [0.748]	8 [0.315]	M14 X 1.5	M33 X 2	41.6 [1.638]	16 [0.630]	14 [0.551]

Bore Code	AA	AB	AC	AE	AF	AH	AJ	AP	AR	AT	AX	AY
20 [0.787]	146 [5.748]	15 [0.591]	126 [4.961]	55 [2.165]	40 [1.575]	25 [0.984]	15.5 [0.610]	6.8 [0.268]	7.5 [0.295]	3.2 [0.126]	31.2 [1.228]	27 [1.063]
25 [0.984]	146 [5.748]	20 [0.787]	126 [4.961]	55 [2.165]	40 [1.575]	30 [1.181]	17 [0.669]	6.8 [0.268]	9.5 [0.374]	3.2 [0.126]	34.6 [1.362]	30 [1.181]
32 [1.260]	146 [5.748]	25 [0.984]	126 [4.961]	55 [2.165]	40 [1.575]	35 [1.378]	20 [0.787]	6.8 [0.268]	9.5 [0.374]	3.2 [0.126]	41.6 [1.638]	36 [1.417]
40 [1.575]	146 [5.748]	25 [0.984]	126 [4.961]	75 [2.953]	55 [2.165]	40 [1.575]	23.5 [0.925]	9 [0.354]	9.5 [0.374]	4 [0.157]	47.3 [1.862]	41 [1.614]

Remarks: Stroke tolerance $+1 \begin{matrix} +0.039in. \\ 0 \end{matrix}$

● $\phi 50, \phi 63$ CS-DA Bore size X Stroke -1

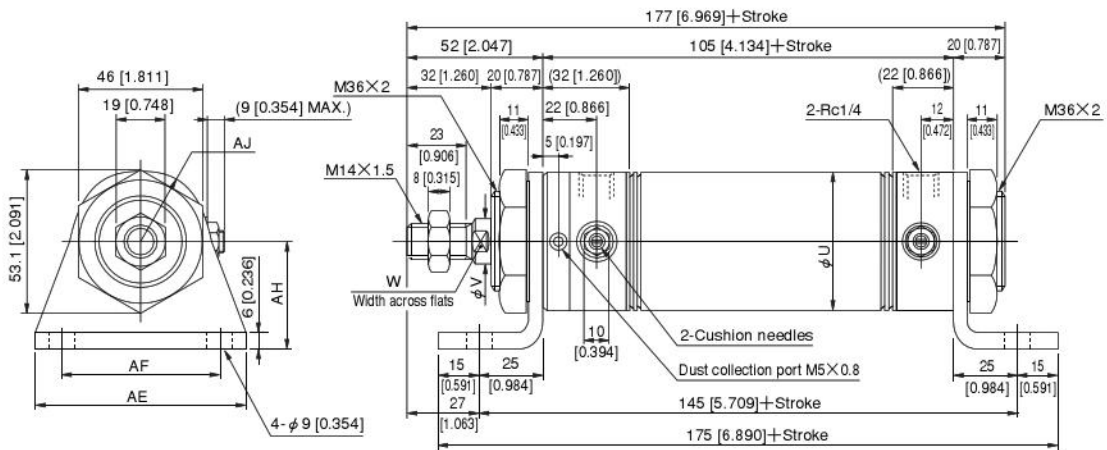

Bore Code	U	V	W	AE	AF	AJ	AH	Cushion stroke	Stroke tolerance
50 [1.969]	52 [2.047]	16 [0.630]	14 [0.551]	80 [3.150]	60 [2.362]	26 [1.024]	40 [1.575]	15 [0.591]	$+1 \begin{matrix} +0.039 \\ 0 \end{matrix}$
63 [2.480]	65.4 [2.575]	16 [0.630]	14 [0.551]	95 [3.740]	74 [2.913]	32 [1.260]	45 [1.772]	15 [0.591]	$+1 \begin{matrix} +0.039 \\ 0 \end{matrix}$

Dimensions of Flange Mounting Type mm [in.]

● $\phi 20 \sim \phi 40$ CS-DA Bore size X Stroke -3

● $\phi 20, \phi 25$

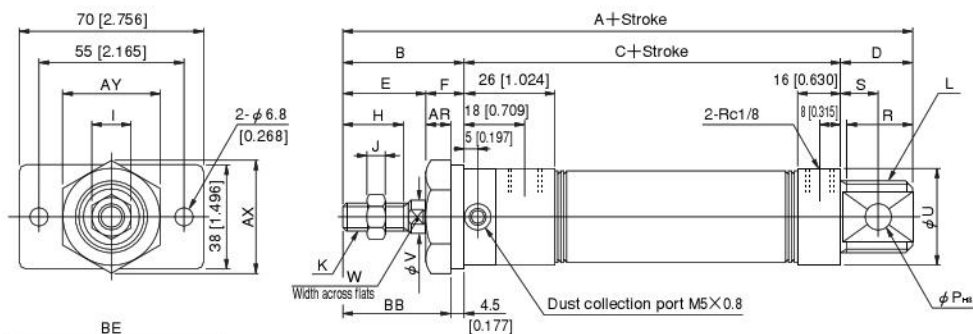

● $\phi 32, \phi 40$

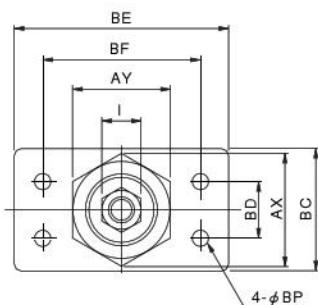

Bore Code	A	B	C	D	E	F	H	I	J	K	L	P	R	S	U	V	W
20 [0.787]	142 [5.591]	35 [1.378]	86 [3.386]	21 [0.827]	23 [0.906]	12 [0.472]	15 [0.591]	12 [0.472]	5 [0.197]	M8 X 1	M20 X 1.5	8 [0.315]	19 [0.748]	12 [0.472]	27 [1.063]	8 [0.315]	6 [0.236]
25 [0.984]	147 [5.787]	40 [1.575]	86 [3.386]	21 [0.827]	26 [1.024]	14 [0.551]	18 [0.709]	14 [0.551]	6 [0.236]	M10 X 1.25	M22 X 1.5	8 [0.315]	19 [0.748]	12 [0.472]	29 [1.142]	10 [0.394]	8 [0.315]
32 [1.260]	158 [6.220]	45 [1.772]	86 [3.386]	27 [1.063]	31 [1.220]	14 [0.551]	23 [0.906]	14 [0.551]	6 [0.236]	M10 X 1.25	M27 X 2	10 [0.394]	25 [0.984]	15 [0.591]	35 [1.378]	12 [0.472]	10 [0.394]
40 [1.575]	158 [6.220]	45 [1.772]	86 [3.386]	27 [1.063]	31 [1.220]	14 [0.551]	23 [0.906]	19 [0.748]	8 [0.315]	M14 X 1.5	M33 X 2	10 [0.394]	25 [0.984]	15 [0.591]	41.5 [1.634]	16 [0.630]	14 [0.551]

Bore Code	AR	AX	AY	BB	BC	BD	BE	BF	BP
20 [0.787]	7.5 [0.295]	31.2 [1.228]	27 [1.063]	30.5 [1.201]	—	—	—	—	—
25 [0.984]	9.5 [0.374]	34.6 [1.362]	30 [1.181]	35.5 [1.398]	—	—	—	—	—
32 [1.260]	9.5 [0.374]	41.6 [1.638]	36 [1.417]	40.5 [1.594]	45 [1.772]	20 [0.787]	80 [3.150]	60 [2.362]	6.8 [0.268]
40 [1.575]	9.5 [0.374]	47.3 [1.862]	41 [1.614]	40.5 [1.594]	50 [1.969]	30 [1.181]	100 [3.937]	80 [3.150]	9 [0.354]

Remarks: Stroke tolerance $+1 \begin{matrix} +0.039 \\ 0 \end{matrix}$

● $\phi 50, \phi 63$ CS-DA Bore size X Stroke -3

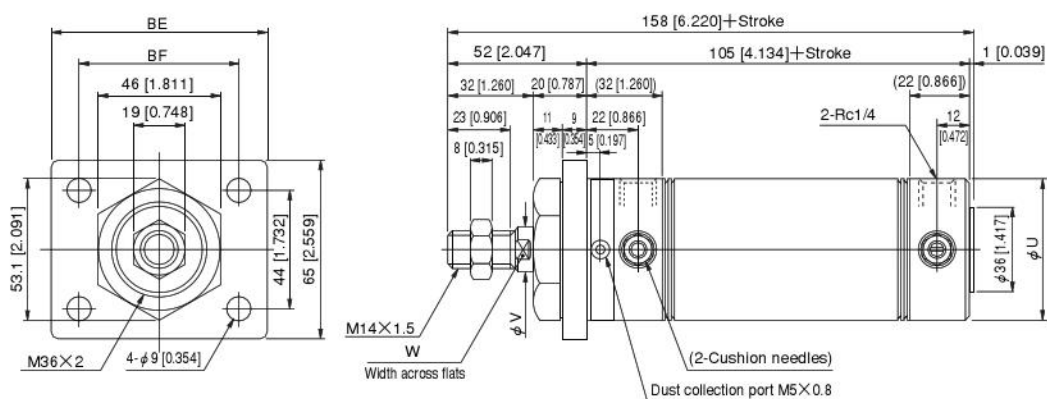

Bore Code	U	V	W	BE	BF	Cushion stroke	Stroke tolerance
50 [1.969]	52 [2.047]	16 [0.630]	14 [0.551]	80 [3.150]	60 [2.362]	15 [0.591]	$+1 \begin{matrix} +0.039 \\ 0 \end{matrix}$
63 [2.480]	65.4 [2.575]	16 [0.630]	14 [0.551]	100 [3.937]	80 [3.150]	15 [0.591]	$+1 \begin{matrix} +0.039 \\ 0 \end{matrix}$

SLIM DOUBLE ROD END CYLINDERS

Double Rod End Double Acting Type

Symbol

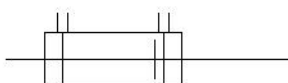

Specifications

Item	Bore size mm [in.]	20~40 [0.787~1.575]
Operating type		Double acting type
Media		Air
Mounting type		Basic type, Foot type, Flange type
Operating pressure range	MPa [psi.]	0.15~0.9 [22~131]
Proof pressure	MPa [psi.]	1.32 [191]
Operating temperature range	°C [°F]	0~60 [32~140]
Operating speed range	mm/s [in./sec.]	50~300 [2.0~11.8]
Cushion		Fixed type (Rubber bumper)
Lubrication		Not required
Port size	Rc	1/8

Bore Size and Stroke

Bore size	Standard strokes	mm [in.]	
		Maximum stroke	Maximum available stroke
20 [0.787]	25 50 75 100 125 150	200	400
25 [0.984]	25 50 75 100 125 150 200	250	
32 [1.260]	25 50 75 100 125 150 200	300	500
40 [1.575]	25 50 75 100 125 150 200 250 300	400	

- Remarks: 1. Stroke tolerance $+0 \begin{matrix} +0.039 \\ 0 \end{matrix}$
 2. For non-standard strokes, consult us.
 3. The minimum operating pressure when the stroke is over the maximum stroke at bore size of $\phi 20[0.787] \sim \phi 40[1.575]$ is 0.2MPa [29psi].

Order Codes

CS - DAD 20×50 - [] - [] - [] - [] - []

Clean system product

Slim cylinder
Double rod end double acting type

Bore size
×
Stroke

Mounting type
Blank — Nose mounting type
1 — Foot mounting type
3 — Flange mounting type
(Mounting brackets are included at shipping.)

Rod end accessory
Blank — Without rod end accessory
Y — Y type knuckle (With pin)
I — I type knuckle (Rod end accessories mounted to one side only.)

Lead wire length
A — 1000mm [39in.]
B — 3000mm [118in.]

Sensor switch
Blank — Without sensor switch
ZG530 — 2-lead wire Solid state type with indicator lamp DC10~28V
ZG553 — 3-lead wire Solid state type with indicator lamp DC4.5~28V
CS3M — 2-lead wire Reed switch type with indicator lamp DC10~30V, AC85~230V
CS4M — 2-lead wire Reed switch type with indicator lamp DC10~30V, AC85~115V
CS5M — 2-lead wire Reed switch type without indicator lamp DC3~30V, AC85~115V
CS2F — 2-lead wire Reed switch type with indicator lamp AC85~230V
CS3F — 2-lead wire Reed switch type with indicator lamp DC10~30V
CS4F — 2-lead wire Reed switch type with indicator lamp DC10~30V
CS5F — 2-lead wire Reed switch type without indicator lamp DC3~30V

● For details of sensor switches, see p.111~121.

Number of sensor switches
1 — With 1 sensor switch
2 — With 2 sensor switches
3 — With 3 sensor switches

● For the order codes of additional parts, see p. 64.

Inner Construction and Major Parts

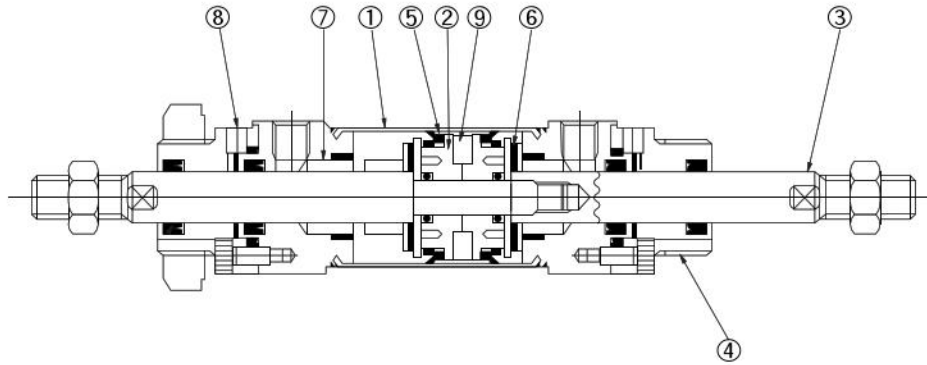

Major Parts and Materials

Parts	Bore size mm	20~40
①	Cylinder tube	Stainless steel
②	Piston	Plastic
③	Piston rod	Steel
④	Rod cover	Aluminum alloy (anodized)
⑤	Seal	Synthetic rubber (NBR)
⑥	Bumper	Synthetic rubber (NBR)
⑦	Rod bushing	Plastic
⑧	Dust prevention cover	Aluminum (anodized)
⑨	Magnet	Plastic magnet
	Mounting bracket	Mild steel (nickel plated)

Seals

Parts	Rod seal	Piston seal	Dust leak prevention seal
Bore mm	Quantity	2	2
20	NY-12×8×3.5	PPY-20	NY-12×8×3.5
25	NY-14×10×3.5	PPY-25	NY-14×10×3.5
32	NY-17×12×4	PPY-32	NY-17×12×4
40	NY-22×16×5	PPY-40	NY-22×16×5

Mass

Bore size mm [in.]	Zero stroke mass			Additional mass for each 1mm [0.0394in.] stroke	Mass of knuckle	
	Basic type	Foot mounting type	Flange mounting type		Y type knuckle	I type knuckle
20 [0.787]	190 [6.70]	330 [11.64]	270 [9.52]	1.2 [0.042]	41 [1.45]	36 [1.27]
25 [0.984]	290 [10.23]	450 [15.87]	370 [13.05]	1.6 [0.056]	75 [2.65]	70 [2.47]
32 [1.260]	430 [15.17]	620 [21.87]	530 [18.69]	2.5 [0.088]	75 [2.65]	70 [2.47]
40 [1.575]	630 [22.22]	920 [32.45]	760 [26.81]	3.9 [0.138]	120 [4.23]	132 [4.66]

Calculation example: For basic type of 40mm bore size and 100mm stroke
 $630 + (3.9 \times 100) = 1020\text{g}$ [35.98 oz.]

Dimensions mm [in.]

● Basic type

● $\phi 20 \sim \phi 40$ CS-DAD X

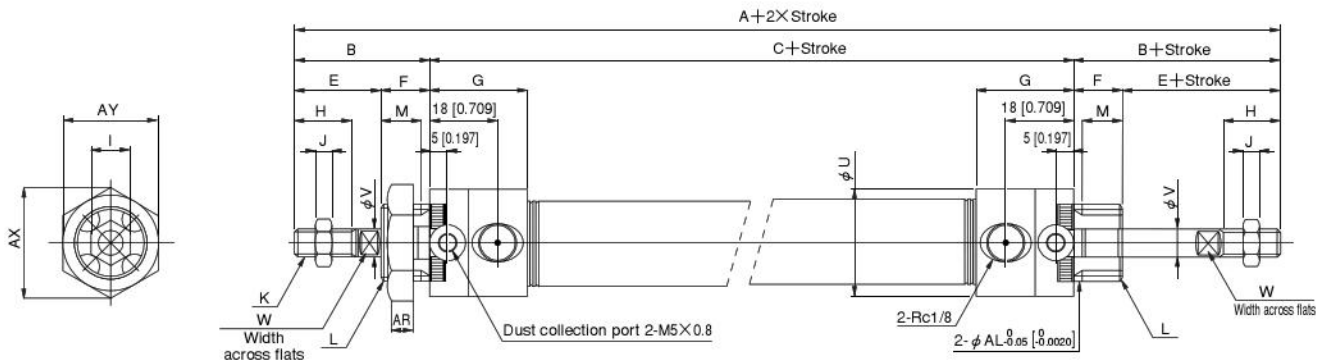

Bore	Code	A	B	C	E	F	G	H	I	J	K	L	M	U	V	W	AR	AX	AY	AL
20	[0.787]	166 [6.535]	35 [1.378]	96 [3.780]	23 [0.906]	12 [0.472]	26 [1.024]	15 [0.591]	12 [0.472]	5 [0.197]	M8 X 1	M20 X 1.5	10 [0.394]	27 [1.063]	8 [0.315]	6 [0.236]	7.5 [0.295]	31.2 [1.228]	27 [1.063]	26 [0.787]
25	[0.984]	176 [6.929]	40 [1.575]	96 [3.780]	26 [1.024]	14 [0.551]	26 [1.024]	18 [0.709]	14 [0.551]	6 [0.236]	M10 X 1.25	M22 X 1.5	12 [0.472]	29 [1.142]	10 [0.394]	8 [0.315]	9.5 [0.374]	34.6 [1.362]	30 [1.181]	22 [0.866]
32	[1.260]	186 [7.323]	45 [1.772]	96 [3.780]	31 [1.220]	14 [0.551]	26 [1.024]	23 [0.906]	14 [0.551]	6 [0.236]	M10 X 1.25	M27 X 2	12 [0.472]	35 [1.378]	12 [0.472]	10 [0.394]	9.5 [0.374]	41.6 [1.638]	36 [1.417]	27 [1.063]
40	[1.575]	186 [7.323]	45 [1.772]	96 [3.780]	31 [1.220]	14 [0.551]	25 [0.984]	23 [0.906]	19 [0.748]	8 [0.315]	M14 X 1.5	M33 X 2	12 [0.472]	41.6 [1.638]	16 [0.630]	14 [0.551]	9.5 [0.374]	47.3 [1.862]	41 [1.614]	33 [1.299]

● Foot mounting type

● $\phi 20 \sim \phi 40$ CS-DAD X -1

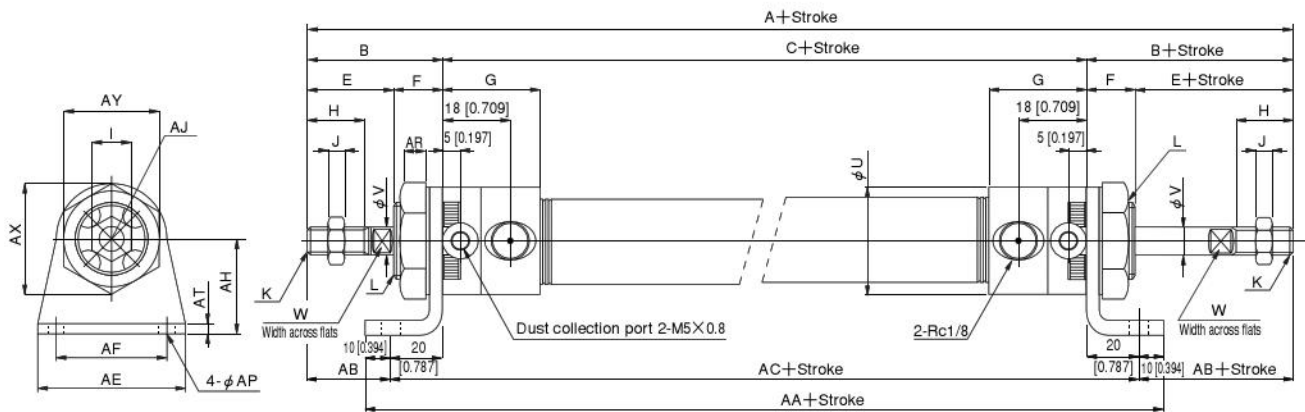

Bore	Code	A	B	C	E	F	G	H	I	J	K	L	U	V	W
20	[0.787]	166 [6.535]	35 [1.378]	96 [3.780]	23 [0.906]	12 [0.472]	26 [1.024]	15 [0.591]	12 [0.472]	5 [0.197]	M8 X 1	M20 X 1.5	27 [1.063]	8 [0.315]	6 [0.236]
25	[0.984]	176 [6.929]	40 [1.575]	96 [3.780]	26 [1.024]	14 [0.551]	26 [1.024]	18 [0.709]	14 [0.551]	6 [0.236]	M10 X 1.25	M22 X 1.5	29 [1.142]	10 [0.394]	8 [0.315]
32	[1.260]	186 [7.323]	45 [1.772]	96 [3.780]	31 [1.220]	14 [0.551]	26 [1.024]	23 [0.906]	14 [0.551]	6 [0.236]	M10 X 1.25	M27 X 2	35 [1.378]	12 [0.472]	10 [0.394]
40	[1.575]	186 [7.323]	45 [1.772]	96 [3.780]	31 [1.220]	14 [0.551]	25 [0.984]	23 [0.906]	19 [0.748]	8 [0.315]	M14 X 1.5	M33 X 2	41.6 [1.638]	16 [0.630]	14 [0.551]

Bore	Code	AA	AB	AC	AE	AF	AH	AJ	AP	AR	AT	AX	AY
20	[0.787]	156 [6.142]	15 [0.591]	136 [5.354]	55 [2.165]	40 [1.575]	25 [0.984]	15.5 [0.610]	6.8 [0.268]	7.5 [0.295]	3.2 [0.126]	31.2 [1.228]	27 [1.063]
25	[0.984]	156 [6.142]	20 [0.787]	136 [5.354]	55 [2.165]	40 [1.575]	30 [1.181]	17 [0.669]	6.8 [0.268]	9.5 [0.374]	3.2 [0.126]	34.6 [1.362]	30 [1.181]
32	[1.260]	156 [6.142]	25 [0.984]	136 [5.354]	55 [2.165]	40 [1.575]	35 [1.378]	20 [0.787]	6.8 [0.268]	9.5 [0.374]	3.2 [0.126]	41.6 [1.638]	36 [1.417]
40	[1.575]	156 [6.142]	25 [0.984]	136 [5.354]	75 [2.953]	55 [2.165]	40 [1.575]	23.5 [0.925]	9 [0.354]	9.5 [0.374]	4 [0.157]	47.3 [1.862]	41 [1.614]

Dimensions of Flange Mounting Type mm [in.]

● $\phi 20 \sim \phi 40$ CS-DAD X -3

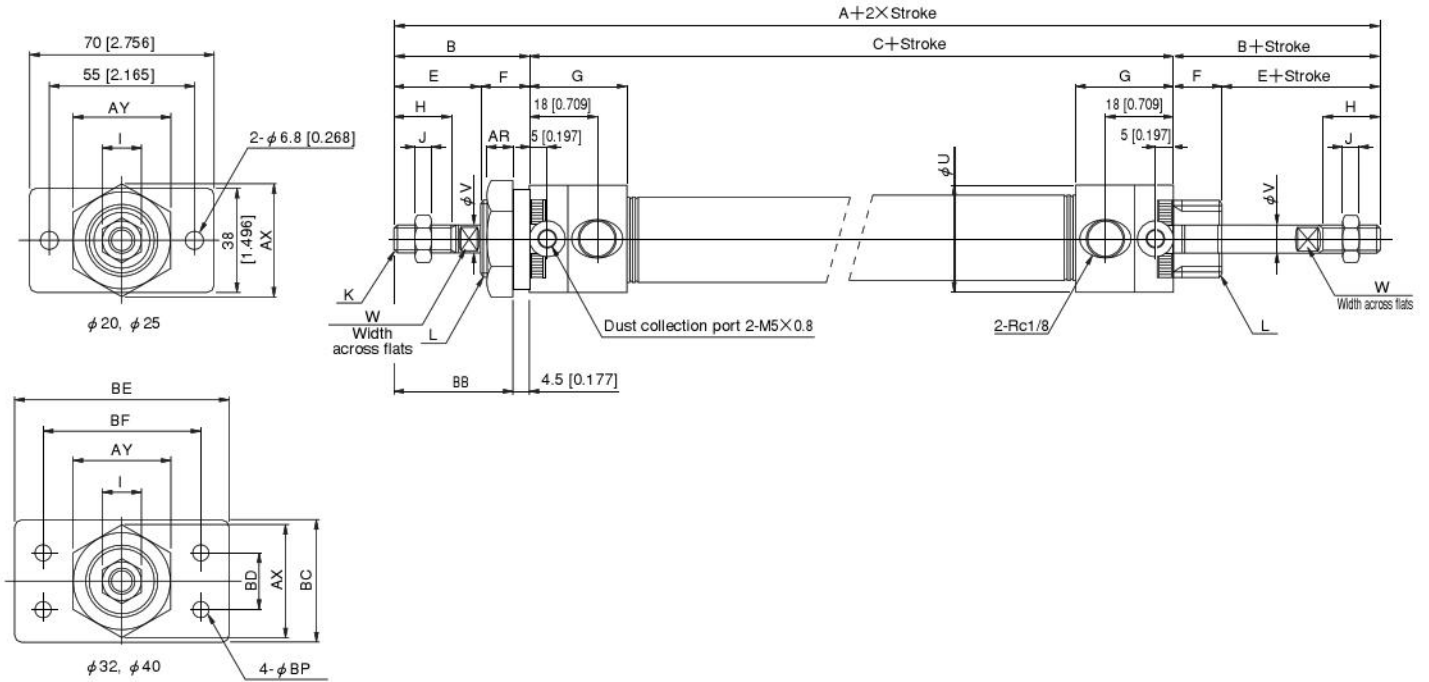

Bore	Code	A	B	C	E	F	G	H	I	J	K	L	U	V	W	AR	AX	AY	BB	BC	BD	BE	BF	BP
20	[0.787]	166 [6.535]	35 [1.378]	96 [3.780]	23 [0.906]	12 [0.472]	26 [1.024]	15 [0.591]	12 [0.472]	5 [0.197]	M8X1	M20X1.5	27 [1.063]	8 [0.315]	6 [0.236]	7.5 [0.295]	31.2 [1.228]	27 [1.063]	30.5 [1.201]	—	—	—	—	—
25	[0.984]	176 [6.929]	40 [1.575]	96 [3.780]	26 [1.024]	14 [0.551]	26 [1.024]	18 [0.709]	14 [0.551]	6 [0.236]	M10X1.25	M22X1.5	29 [1.142]	10 [0.394]	8 [0.315]	9.5 [0.374]	34.6 [1.362]	30 [1.181]	35.5 [1.398]	—	—	—	—	—
32	[1.260]	186 [7.323]	45 [1.772]	96 [3.780]	31 [1.220]	14 [0.551]	26 [1.024]	23 [0.906]	14 [0.551]	6 [0.236]	M10X1.25	M27X2	35 [1.378]	12 [0.472]	10 [0.394]	9.5 [0.374]	41.6 [1.638]	36 [1.417]	40.5 [1.594]	45 [1.772]	20 [0.787]	80 [3.150]	60 [2.362]	6.8 [0.268]
40	[1.575]	186 [7.323]	45 [1.772]	96 [3.780]	31 [1.220]	14 [0.551]	25 [0.984]	23 [0.906]	19 [0.748]	8 [0.315]	M14X1.5	M33X2	41.6 [1.638]	16 [0.630]	14 [0.551]	9.5 [0.374]	47.3 [1.862]	41 [1.614]	40.5 [1.594]	50 [1.969]	30 [1.181]	100 [3.937]	80 [3.150]	9 [0.354]

SLIM END KEEP CYLINDERS

Head Side End Keep Double Acting Type

Symbol

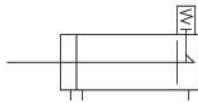

Specifications

Item	Bore size mm [in.]	20 [0.787]	25 [0.984]	32 [1.260]	40 [1.575]
Operating type		Double acting type, with head side end keep mechanism			
Media		Air			
Mounting type		Basic type, Foot type, Flange type			
Operating pressure range	MPa [psi.]	0.1~0.9 [15~131]			
Proof pressure	MPa [psi.]	1.32 [191]			
Operating temperature range	°C [°F]	0~60 [32~140]			
Operating speed range	mm/s [in./sec.]	50~300 [2.0~11.8]			
Cushion		Fixed type (Rubber bumper)			
Lubrication		Not required			
Maximum holding force (at end keep)	N [lbf.]	194.2 [43.66]	303 [68.11]	496.2 [111.5]	775.7 [174.4]
Backlash (at end keep)	mm [in.]	1.4 [0.055] MAX.		1.6 [0.063] MAX.	
Port size	Rc	1/8			

Bore Size and Stroke

Bore size	Standard strokes							Maximum stroke	Maximum available stroke
	25	50	75	100	125	150	200		
20 [0.787]	25	50	75	100	125	150		200	1050
25 [0.984]	25	50	75	100	125	150	200	250	
32 [1.260]	25	50	75	100	125	150	200	300	
40 [1.575]	25	50	75	100	125	150	200	250	

Remarks: 1. Stroke tolerance ${}_{0}^{+1} [{}_{0}^{+0.039}]$

2. For non-standard strokes, consult us.

3. The minimum operating pressure when the stroke is over the maximum stroke at bore size of $\phi 20 [0.787] \sim \phi 40 [1.575]$ is 0.2MPa [29psi.].

Order Codes

CS - DAK 20×50 [] - [] - [] - [] - [] - [] - []

- Clean system product**
- Slim cylinder**
End keep double acting cylinder
- Bore size X Stroke**
- Head cover type**
Blank — Standard head
A — Short head
- End keep position**
HL — Head side end keep
- Mounting type**
Blank — Basic type
1 — Double foot mounting type
3 — Flange mounting type
(Mounting brackets are included at shipping.)
- Rod end accessory**
Blank — Without rod end accessory
Y — Y type knuckle (With pin)
I — I type knuckle
- Lead wire length**
A — 1000mm [39in.]
B — 3000mm [118in.]
- Sensor switch**
Blank — Without sensor switch
ZG530 — 2-lead wire Solid state type with indicator lamp DC10~28V
ZG553 — 3-lead wire Solid state type with indicator lamp DC4.5~28V
CS3M — 2-lead wire Reed switch type with indicator lamp DC10~30V, AC85~230V
CS4M — 2-lead wire Reed switch type with indicator lamp DC10~30V, AC85~115V
CS5M — 2-lead wire Reed switch type without indicator lamp DC3~30V, AC85~115V
CS2F — 2-lead wire Reed switch type with indicator lamp AC85~230V
CS3F — 2-lead wire Reed switch type with indicator lamp DC10~30V
CS4F — 2-lead wire Reed switch type with indicator lamp DC10~30V
CS5F — 2-lead wire Reed switch type without indicator lamp DC3~30V
- Number of sensor switches**
1 — With 1 sensor switch
2 — With 2 sensor switches
3 — With 3 sensor switches

● For details of sensor switches, see p.111~121.

● For the order codes of additional parts, see p. 64.

Inner Construction and Major Parts

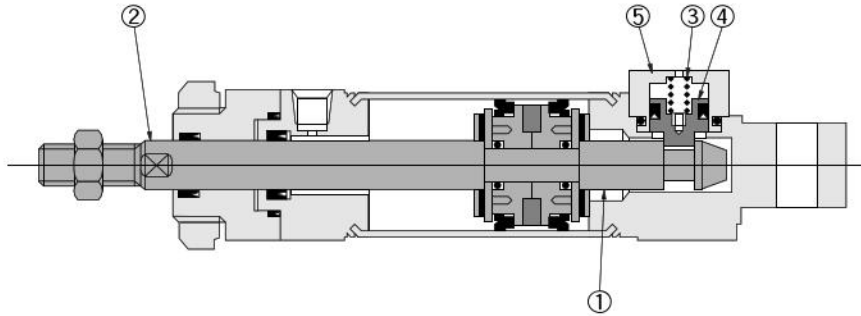

Major Parts and Materials

Parts		Bore size mm	20, 25	32, 40
①	Piston rod A		Steel (chrome plated)	
②	Piston rod B		Stainless steel	
③	Spring		Stainless steel	Piano wire
④	Lock piston		Stainless steel	
⑤	Lock cover		Aluminum alloy (anodized)	
	Y type knuckle, I type knuckle		Mild steel (nickel plated)	

Other than the items listed above, they are the same as for the standard Slim Cylinder.

Seals

Parts		Rod seal	Lock piston seal	Lock cover gasket
Bore mm	Quantity	1	1	1
20		GYH-9	MYN-5	—
25		GYH-11	MYN-5	—
32		—	MYN-10A	S18
40		—	MYN10-A	S18

Other than the items listed above, they are the same as for the standard Slim Cylinder.

Mass

Bore size mm [in.]	Zero stroke mass		Additional mass for each 1mm [0.0394in.] stroke	Mass of mounting bracket				
	-HL: Head side end keep			Foot bracket	Flange bracket	Pivot bracket	Y type knuckle	I type knuckle
	Basic type	Short head type						
20 [0.787]	170 [6.00]	160 [5.64]	0.8 [0.028]	140 [4.94]	80 [2.82]	60 [2.12]	41 [1.45]	36 [1.27]
25 [0.984]	240 [8.47]	230 [8.11]	1.1 [0.039]	160 [5.64]	80 [2.82]	60 [2.12]	75 [2.65]	70 [2.47]
32 [1.260]	410 [14.46]	390 [13.76]	1.5 [0.053]	190 [6.70]	100 [3.53]	140 [4.94]		
40 [1.575]	580 [20.46]	560 [19.75]	2.4 [0.085]	290 [10.23]	130 [4.59]	140 [4.94]	120 [4.23]	132 [4.66]

Calculation example: For head side end keep foot mounting type of 32mm bore size and 100mm stroke
 $410 + 190 + (1.5 \times 100) = 750\text{g [26.46 oz.]}$

-HL Dimensions of Head Side End Keep Basic Type mm [in.]

● $\phi 20 \sim \phi 40$ CS-DAK X -HL

● Short head

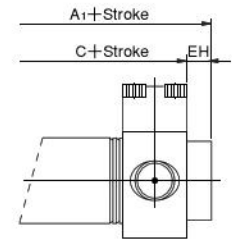
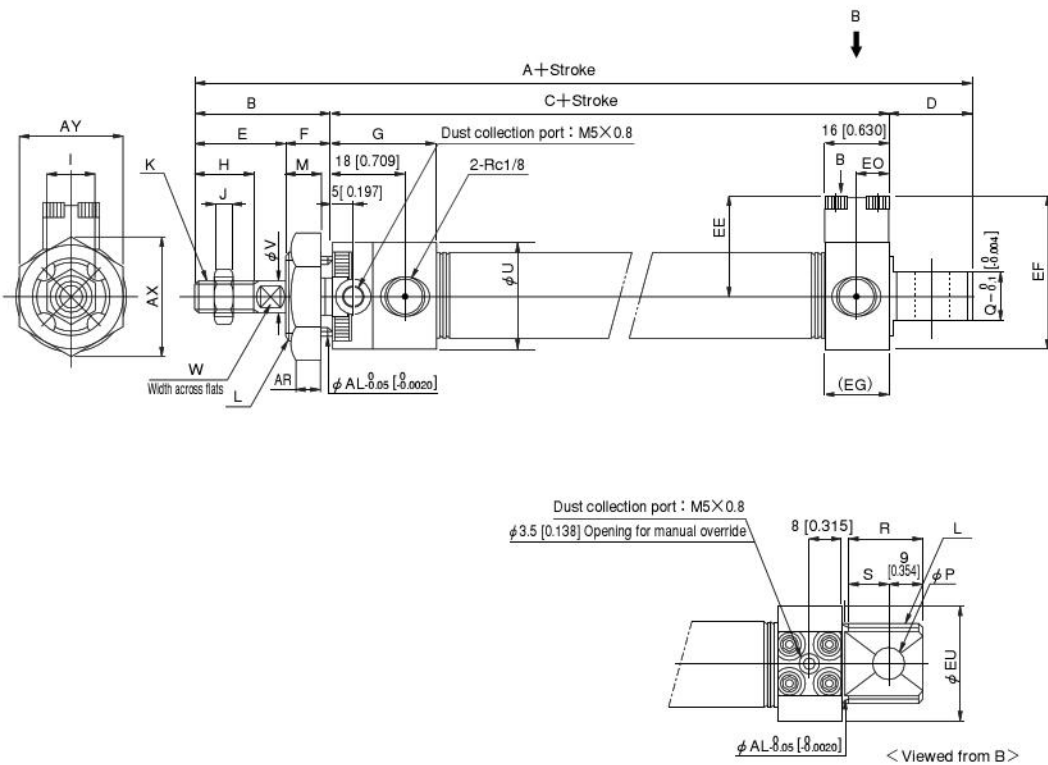

Bore	Code	A	A ₁	B	C	D	E	F	G	H	I	J	K	L	M	P	Q	R	S	U	V	W
20	[0.787]	142 [5.591]	127 [5.000]	35 [1.378]	86 [3.386]	21 [0.827]	23 [0.906]	12 [0.472]	26 [1.024]	15 [0.591]	12 [0.472]	5 [0.197]	M8x1	M20x1.5	10 [0.394]	8 [0.315]	12 [0.472]	19 [0.748]	10 [0.394]	27 [1.063]	8 [0.315]	6 [0.236]
25	[0.984]	147 [5.787]	132 [5.197]	40 [1.575]	86 [3.386]	21 [0.827]	26 [1.024]	14 [0.551]	26 [1.024]	18 [0.709]	14 [0.551]	6 [0.236]	M10x1.25	M22x1.5	12 [0.472]	8 [0.315]	12 [0.472]	19 [0.748]	10 [0.394]	29 [1.142]	10 [0.394]	8 [0.315]
32	[1.260]	170 [6.693]	144 [5.669]	45 [1.772]	98 [3.858]	27 [1.063]	31 [1.220]	14 [0.551]	26 [1.024]	23 [0.906]	14 [0.551]	6 [0.236]	M10x1.25	M27x2	12 [0.472]	10 [0.394]	20 [0.787]	25 [0.984]	15 [0.591]	35 [1.378]	12 [0.472]	10 [0.394]
40	[1.575]	175 [6.890]	149 [5.866]	45 [1.772]	103 [4.055]	27 [1.063]	31 [1.220]	14 [0.551]	25 [0.984]	23 [0.906]	19 [0.748]	8 [0.315]	M14x1.5	M33x2	12 [0.472]	10 [0.394]	20 [0.787]	25 [0.984]	15 [0.591]	41.6 [1.638]	16 [0.630]	14 [0.551]

Bore	Code	AR	AX	AY	AL	EE	EF	EG	EH	EO
20	[0.787]	7.5 [0.295]	31.2 [1.228]	27 [1.063]	20 [0.787]	24 [0.945]	38.5 [1.516]	16 [0.630]	6 [0.236]	8 [0.315]
25	[0.984]	9.5 [0.374]	34.6 [1.362]	30 [1.181]	22 [0.866]	25 [0.984]	42.5 [1.673]	16 [0.630]	6 [0.236]	8 [0.315]
32	[1.260]	9.5 [0.374]	41.6 [1.638]	36 [1.417]	27 [1.063]	30 [1.181]	47.5 [1.870]	26 [1.024]	1 [0.039]	14 [0.551]
40	[1.575]	9.5 [0.374]	47.3 [1.862]	41 [1.614]	33 [1.299]	32.2 [1.268]	53 [2.087]	31 [1.220]	1 [0.039]	16 [0.630]

SLIM BLOCK CYLINDERS

Double Acting Type

Symbol

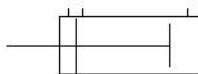

Specifications

Item	Bore size mm [in.]	16~40 [0.630~1.575]
Operating type		Double acting type
Media		Air
Mounting type		Side mount, Front mount
Operating pressure range MPa [psi.]		0.1~0.9 [15~131]
Proof pressure MPa [psi.]		1.32 [191]
Operating temperature range °C [°F]		0~60 [32~140]
Operating speed range mm/s [in./sec.]		30~300 [1.2~11.8]
Cushion		Fixed type (Rubber bumper)
Lubrication		Not required
Port size	Rc	1/8

Bore Size and Stroke

Bore size	Standard strokes	mm [in.]	
		Maximum stroke	Maximum available stroke
16 [0.630]	15 25 50 75 100	100	300
20 [0.787]	25 50 75 100 125 150	150	500
25 [0.984]	25 50 75 100 125 150 200	200	
32 [1.260]	25 50 75 100 125 150 200	200	
40 [1.575]	25 50 75 100 125 150 200 250 300	300	

Remarks: 1. Stroke tolerance $^{+1}_{0} [^{+0.039}_{0}]$
 2. For non-standard strokes, consult us.

Order Codes

CS — **DAB** **20×50** — [] — [] — [] — [] — []

Clean system product
 Slim cylinder
 Block double acting type

Bore size
 X
Stroke

Mounting type
 2 — Side mount
 4 — Front mount

Rod end accessory
 Blank — Without rod end accessory
 Y — Y type knuckle (With pin)
 I — I type knuckle

Lead wire length
 A — 1000mm [39in.]
 B — 3000mm [118in.]

Number of sensor switches
 1 — With 1 sensor switch
 2 — With 2 sensor switches
 3 — With 3 sensor switches

Sensor switch
 Blank — Without sensor switch
ZG530 — 2-lead wire Solid state type with indicator lamp DC10~28V
ZG553 — 3-lead wire Solid state type with indicator lamp DC4.5~28V
CS3M — 2-lead wire Reed switch type with indicator lamp DC10~30V, AC85~230V
CS4M — 2-lead wire Reed switch type with indicator lamp DC10~30V, AC85~115V
CS5M — 2-lead wire Reed switch type without indicator lamp DC3~30V, AC85~115V
CS2F — 2-lead wire Reed switch type with indicator lamp AC85~230V
CS3F — 2-lead wire Reed switch type with indicator lamp DC10~30V
CS4F — 2-lead wire Reed switch type with indicator lamp DC10~30V
CS5F — 2-lead wire Reed switch type without indicator lamp DC3~30V

● For details of sensor switches, see p.111~121.

● For the order codes of additional parts, see p. 64.

Inner Construction and Major Parts

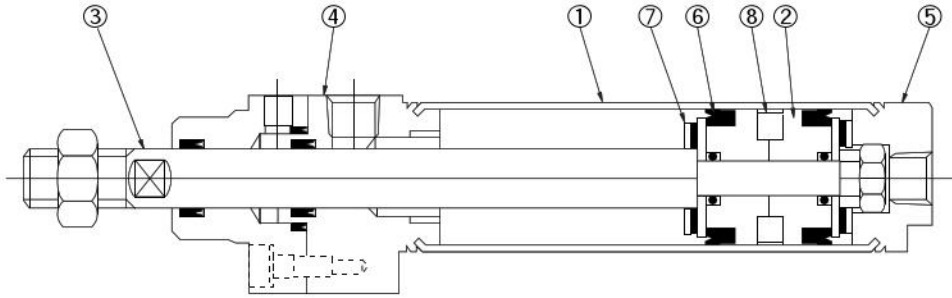

Major Parts and Materials

Parts	Bore size mm	16~40
①	Cylinder tube	Stainless steel
②	Piston	Plastic
③	Piston rod	Stainless steel
④	Rod cover	Aluminum (anodized)
⑤	Head cover	
⑥	Seal	Synthetic rubber (NBR)
⑦	Bumper	
⑧	Magnet	Plastic magnet
	I type knuckle, Y type knuckle	Mild steel (nickel plated)

Seals

Parts	Rod seal	Piston seal	Dust leak prevention seal
Bore mm	Quantity	1	2
16	1	2	1
20	1	2	1
25	1	2	1
32	1	2	1
40	1	2	1

Other than the items listed above, they are the same as for the standard Slim Cylinder.

Mass

Bore size mm [in.]	Zero stroke mass		Additional mass for each 1mm [0.0394in.] stroke	Mass of knuckle	
	Side mount	Front mount		Y type knuckle	I type knuckle
16 [0.630]	90 [3.17]	80 [2.82]	0.5 [0.018]	17 [0.60]	20 [0.71]
20 [0.787]	160 [5.64]	130 [4.59]	0.8 [0.028]	41 [1.45]	36 [1.27]
25 [0.984]	220 [7.76]	190 [6.70]	1.1 [0.039]	75 [2.65]	70 [2.47]
32 [1.260]	340 [11.99]	270 [9.52]	1.5 [0.053]	75 [2.65]	70 [2.47]
40 [1.575]	560 [19.75]	390 [13.76]	2.4 [0.085]	120 [4.23]	132 [4.66]

Calculation example: For the mass of side mount type of 32mm bore size and 100mm stroke
 $340 + (1.5 \times 100) = 490\text{g}$ [17.28 oz.]

Dimensions of Block Cylinder Side Mounting Type mm [in.]

● $\phi 16$ CS-DAB16 \times -2

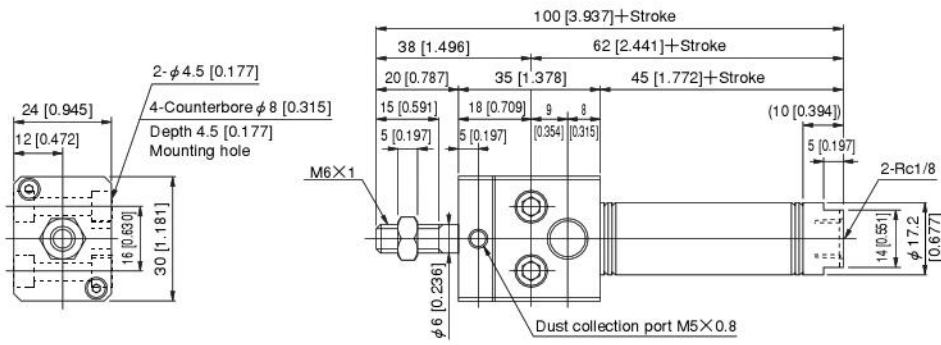

● $\phi 20 \sim \phi 40$ CS-DAB \times \times -2

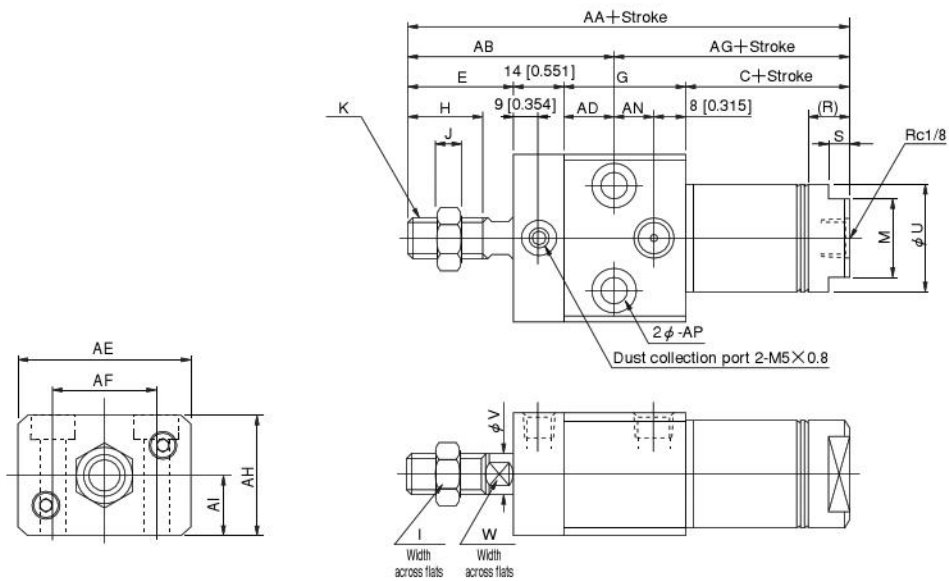

Bore Code	C	E	G	H	I	J	K	M	R	S	U	V	W	AA	AB	AD	AE	AF	AG	AH	AI	AN	AP
20 [0.787]	53 [2.087]	23 [0.906]	28 [1.102]	15 [0.591]	12 [0.472]	5 [0.197]	M8 \times 1	17 [0.669]	9 [0.354]	5 [0.197]	21.4 [0.843]	8 [0.315]	6 [0.236]	118 [4.646]	48 [1.890]	11 [0.433]	38 [1.496]	22 [0.866]	70 [2.756]	28 [1.102]	14 [0.551]	9 [0.354]	ϕ 6.6 [0.260] Counterbore ϕ 11 [0.433] Depth 6.5 [0.256]
25 [0.984]	53 [2.087]	26 [1.024]	30 [1.181]	18 [0.709]	14 [0.551]	6 [0.236]	M10 \times 1.25	19 [0.748]	9 [0.354]	5 [0.197]	26.4 [1.039]	10 [0.394]	8 [0.315]	123 [4.843]	52 [2.047]	12 [0.472]	42 [1.654]	26 [1.024]	71 [2.795]	30 [1.181]	15 [0.591]	10 [0.394]	ϕ 6.6 [0.260] Counterbore ϕ 11 [0.433] Depth 6.5 [0.256]
32 [1.260]	54 [2.126]	31 [1.220]	36 [1.417]	23 [0.906]	14 [0.551]	6 [0.236]	M10 \times 1.25	22 [0.866]	10 [0.394]	6 [0.236]	33.6 [1.323]	12 [0.472]	10 [0.394]	135 [5.315]	59 [2.323]	14 [0.551]	54 [2.126]	34 [1.339]	76 [2.992]	36 [1.417]	18 [0.709]	14 [0.551]	ϕ 9 [0.354] Counterbore ϕ 14 [0.551] Depth 8.6 [0.339]
40 [1.575]	60 [2.362]	31 [1.220]	44 [1.732]	23 [0.906]	19 [0.748]	8 [0.315]	M14 \times 1.5	22 [0.866]	12 [0.472]	6 [0.236]	41.6 [1.638]	16 [0.630]	14 [0.551]	149 [5.866]	62 [2.441]	17 [0.669]	68 [2.677]	46 [1.811]	87 [3.425]	44 [1.732]	22 [0.866]	19 [0.748]	ϕ 11 [0.433] Counterbore ϕ 17.5 [0.689] Depth 10.8 [0.425]

Dimensions of Front Mounting Type mm [in.]

● $\phi 16$ CS-DAB16 \times -4

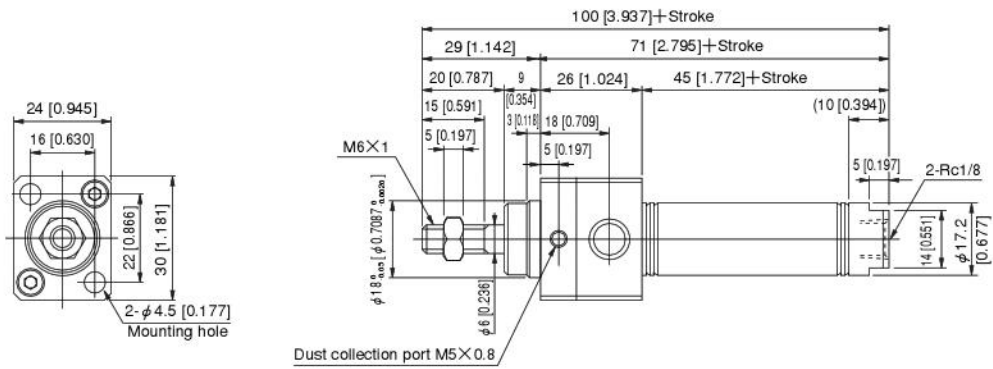

● $\phi 20 \sim \phi 40$ CS-DAB \times -4

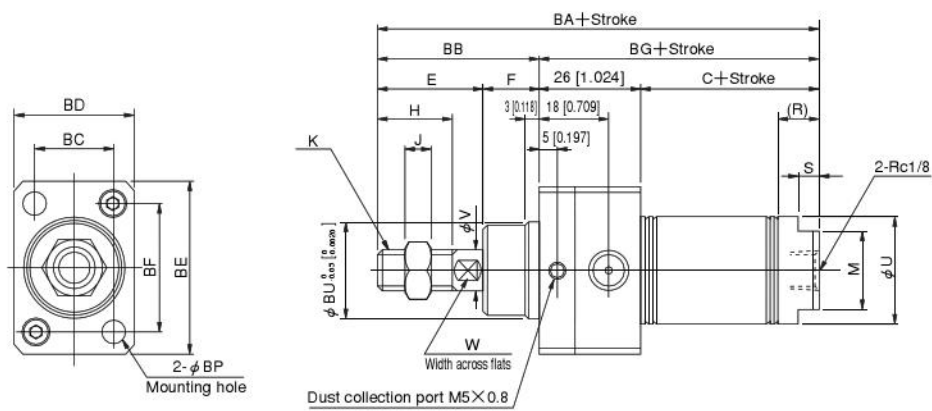

Bore	Code	C	E	F	H	I	J	K	M	R	S	U	V	W	BA	BB	BC	BD	BE	BF	BG	BP	BU
20	[0.787]	53 [2.087]	23 [0.906]	12 [0.472]	15 [0.591]	12 [0.472]	5 [0.197]	M8 \times 1	17 [0.669]	10 [0.394]	5 [0.197]	21.4 [0.843]	8 [0.315]	6 [0.236]	114 [4.488]	35 [1.378]	28 [1.102]	18 [0.709]	38 [1.496]	28 [1.102]	79 [3.110]	5.5 [0.217]	22 [0.866]
25	[0.984]	53 [2.087]	26 [1.024]	14 [0.551]	18 [0.709]	14 [0.551]	6 [0.236]	M10 \times 1.25	19 [0.748]	10 [0.394]	5 [0.197]	26.4 [1.039]	10 [0.394]	8 [0.315]	119 [4.685]	40 [1.575]	30 [1.181]	20 [0.787]	42 [1.654]	32 [1.260]	79 [3.110]	5.5 [0.217]	24 [0.945]
32	[1.260]	54 [2.126]	31 [1.220]	14 [0.551]	23 [0.906]	14 [0.551]	6 [0.236]	M10 \times 1.25	22 [0.866]	11 [0.433]	6 [0.236]	33.6 [1.323]	12 [0.472]	10 [0.394]	125 [4.921]	45 [1.772]	36 [1.417]	24 [0.945]	54 [2.126]	42 [1.654]	80 [3.150]	6.6 [0.260]	28 [1.102]
40	[1.575]	60 [2.362]	31 [1.220]	14 [0.551]	23 [0.906]	19 [0.748]	8 [0.315]	M14 \times 1.5	22 [0.866]	13 [0.512]	6 [0.236]	41.6 [1.638]	16 [0.630]	14 [0.551]	131 [5.157]	45 [1.772]	44 [1.732]	28 [1.102]	68 [2.677]	52 [2.047]	86 [3.386]	9 [0.354]	34 [1.339]

Inner Construction and Major Parts

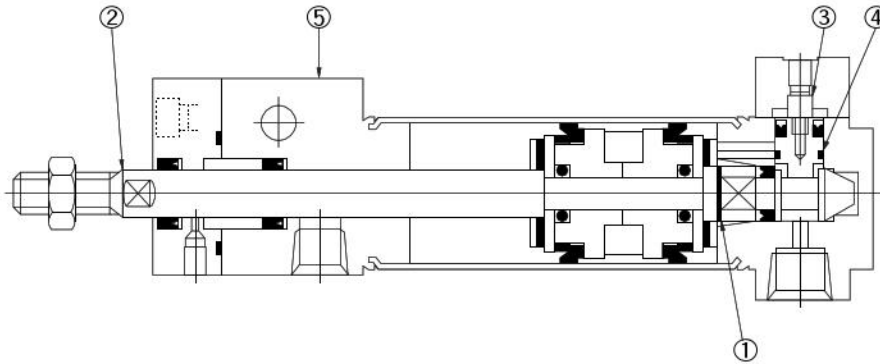

Major Parts and Materials

Parts	Bore size mm	20, 25	32, 40
①	Piston rod A	Steel (chrome plated)	
②	Piston rod B	Stainless steel	
③	Spring	Stainless steel	Piano wire
④	Lock piston	Stainless steel	
⑤	Lock cover	Aluminum (anodized)	
	Y type knuckle, I type knuckle	Mild steel (nickel plated)	

Other than the items listed above, it is the same as for the standard Slim Cylinder.

Seals

Parts	Rod seal	Lock piston seal	Lock cover gasket
Bore mm	Quantity	1	1
20	GYH-9	MYN-5	—
25	GYH-11	MYN-5	—
32	—	MYN-10A	S18
40	—	MYN10-A	S18

Other than the items listed above, it is the same as for the standard Slim Cylinder.

Mass

Bore size mm [in.]	Zero stroke mass		Additional mass for each 1mm [0.0394in.] stroke	Mass of knuckle	
	-HL : Head side end keep Side mount			Y type knuckle	I type knuckle
20 [0.787]	210 [7.41]		0.8 [0.028]	41 [1.45]	36 [1.27]
25 [0.984]	310 [10.93]		1.1 [0.039]	75 [2.65]	70 [2.47]
32 [1.260]	500 [17.64]		1.5 [0.053]		
40 [1.575]	900 [31.75]		2.4 [0.085]	120 [4.23]	132 [4.66]

Calculation example: For head side end keep side mount type of 32mm bore size and 100mm stroke, $500 + (1.5 \times 100) = 650\text{g}$ [22.93 oz.]

-HL Dimensions of Head Side End Keep, Side Mounting Type mm [in.]

● $\phi 20 \sim \phi 40$

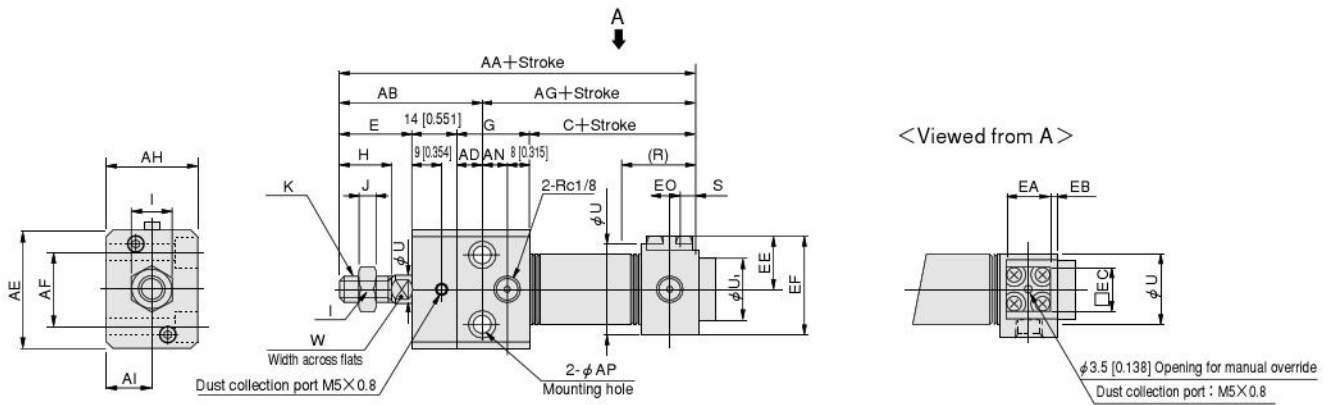

● The drawings for sizes $\phi 32$ and $\phi 40$ (The outward shape of the size $\phi 20$ and $\phi 25$ head covers is larger than the block portion.)

Bore	Code	C	E	G	H	I	J	K	R	S	U	U _t	V	W
20	[0.787]	60 [2.362]	23 [0.906]	28 [1.102]	15 [0.591]	12 [0.472]	5 [0.197]	M8×1	16 [0.630]	6 [0.236]	29 [1.142]	20 [0.787]	8 [0.315]	6 [0.236]
25	[0.984]	60 [2.362]	26 [1.024]	30 [1.181]	18 [0.709]	14 [0.551]	6 [0.236]	M10×1.25	16 [0.630]	6 [0.236]	35 [1.378]	22 [0.866]	10 [0.394]	8 [0.315]
32	[1.260]	72 [2.835]	31 [1.220]	36 [1.417]	23 [0.906]	14 [0.551]	6 [0.236]	M10×1.25	26 [1.024]	1 [0.039]	35 [1.378]	27 [1.063]	12 [0.472]	10 [0.394]
40	[1.575]	79 [3.110]	31 [1.220]	44 [1.732]	23 [0.906]	19 [0.748]	8 [0.315]	M14×1.5	32 [1.260]	1 [0.039]	41.6 [1.638]	33 [1.299]	16 [0.630]	14 [0.551]

Bore	Code	AA	AB	AD	AE	AF	AG	AH	AI	AN	AP	EA	EB	EC	EE	EF	EO
20	[0.787]	131 [5.157]	48 [1.890]	11 [0.433]	38 [1.496]	22 [0.866]	83 [3.268]	28 [1.102]	14 [0.551]	9 [0.354]	φ 6.6 [0.260] Counterbore φ 11 [0.433] Depth 6.5 [0.256]	16 [0.630]	—	16 [0.630]	24 [0.945]	38.5 [1.516]	8 [0.315]
25	[0.984]	136 [5.354]	52 [2.047]	12 [0.472]	42 [1.654]	26 [1.024]	84 [3.307]	30 [1.181]	15 [0.591]	10 [0.394]	φ 6.6 [0.260] Counterbore φ 11 [0.433] Depth 6.5 [0.256]	16 [0.630]	—	16 [0.630]	25 [0.984]	42.5 [1.673]	8 [0.315]
32	[1.260]	154 [6.063]	59 [2.323]	14 [0.551]	54 [2.126]	34 [1.339]	95 [3.740]	36 [1.417]	18 [0.709]	14 [0.551]	φ 9 [0.354] Counterbore φ 14 [0.551] Depth 8.6 [0.339]	24 [0.945]	2 [0.079]	25 [0.984]	30 [1.181]	40.5 [1.594]	14 [0.551]
40	[1.575]	169 [6.654]	62 [2.441]	17 [0.669]	68 [2.677]	46 [1.811]	107 [4.213]	44 [1.732]	22 [0.866]	19 [0.748]	φ 11 [0.433] Counterbore φ 17.5 [0.689] Depth 10.8 [0.425]	24 [0.945]	4 [0.157]	25 [0.984]	32.5 [1.280]	46 [1.811]	16 [0.630]

SLIM CYLINDERS

Sensor Switches

- Since a magnet comes standard in the Slim cylinders series, mounting a sensor switch will enable use in sensor switch applications.

Symbol



Order Codes

● Order codes for sensor switch with mounting strap



Lead wire length
(Applies to all except CS□F)
A — 1000mm [39in.]
B — 3000mm [118in.]

Cylinder basic type
DA — Excluding DAB ϕ 16 and DABK ϕ 16
DAB — For block cylinder ϕ 16
DABK — For block type end keep cylinder ϕ 16
S — For sensor switch type CS□F

Bore size Note

- 16 — ϕ 16 [0.630in.]
 - 20 — ϕ 20 [0.787in.]
 - 25 — ϕ 25 [0.984in.]
 - 32 — ϕ 32 [1.260in.]
 - 40 — ϕ 40 [1.575in.]
 - 50 — ϕ 50 [1.969in.]
 - 63 — ϕ 63 [2.480in.]
- Note: ϕ 50 and ϕ 63 are DA type only.

Sensor switch

- ZG530 — 2-lead wire Solid state type with indicator lamp DC10~28V
- ZG553 — 3-lead wire Solid state type with indicator lamp DC4.5~28V
- CS3M — 2-lead wire Reed switch type with indicator lamp DC10~30V, AC85~230V
- CS4M — 2-lead wire Reed switch type with indicator lamp DC10~30V, AC85~115V
- CS5M — 2-lead wire Reed switch type without indicator lamp DC3~30V, AC85~115V
- CS2F — 2-lead wire Reed switch type with indicator lamp AC85~230V
- CS3F — 2-lead wire Reed switch type with indicator lamp DC10~30V
- CS4F — 2-lead wire Reed switch type with indicator lamp DC10~30V
- CS5F — 2-lead wire Reed switch type without indicator lamp DC3~30V

● For details of sensor switches, see p.111~121.

Clean system product

● Order codes for sensor switch only

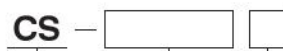

Lead wire length
(Applies to all except CS□F)
A — 1000mm [39in.]
B — 3000mm [118in.]

Sensor switch

- ZG530 — 2-lead wire Solid state type with indicator lamp DC10~28V
- ZG553 — 3-lead wire Solid state type with indicator lamp DC4.5~28V
- CS3M — 2-lead wire Reed switch type with indicator lamp DC10~30V, AC85~230V
- CS4M — 2-lead wire Reed switch type with indicator lamp DC10~30V, AC85~115V
- CS5M — 2-lead wire Reed switch type without indicator lamp DC3~30V, AC85~115V
- CS2F — 2-lead wire Reed switch type with indicator lamp AC85~230V
- CS3F — 2-lead wire Reed switch type with indicator lamp DC10~30V
- CS4F — 2-lead wire Reed switch type with indicator lamp DC10~30V
- CS5F — 2-lead wire Reed switch type without indicator lamp DC3~30V

● For details of sensor switches, see p.111~121.

Clean system product

● Order codes for mounting strap only

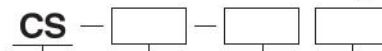

Bore size Note

- 16 — ϕ 16 [0.630in.]
 - 20 — ϕ 20 [0.787in.]
 - 25 — ϕ 25 [0.984in.]
 - 32 — ϕ 32 [1.260in.]
 - 40 — ϕ 40 [1.575in.]
 - 50 — ϕ 50 [1.969in.]
 - 63 — ϕ 63 [2.480in.]
- Note: ϕ 50 and ϕ 63 are DA type only.

Cylinder basic type

- DA — Excluding DAB ϕ 16 and DABK ϕ 16
- DAB — For block cylinder DAB ϕ 16
- DABK — For block end keep cylinder DABK ϕ 16
- S — For sensor switch type CS□F

Mounting strap type

- G5 — Solid state type
For ZG5□□
- Reed switch type
For CS□M
- F — Reed switch type
For CS□F

Clean system product

Minimum Cylinder Strokes When Using Sensor Switches

Sensor switch model	Bore size	mm [in.]		
		2 pcs. mounting		1 pc. mounting
		In-line	In staggered positions	
ZG530	16 [0.630]	20 [0.787]	10 [0.394]	10 [0.394]
ZG553	20~63 [0.787~2.480]	20 [0.787]	10 [0.394]	10 [0.394]
CS□M	16~63 [0.630~2.480]	20 [0.787]	15 [0.591]	15 [0.591]
CS□F	20~63 [0.787~2.480]	40 [1.575]	21 [0.827]	15 [0.591]

● Two pieces mounting ● One piece mounting

● When mounted in-line

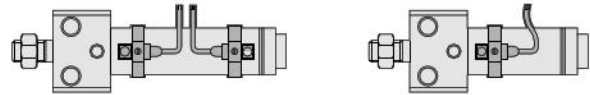

● When mounted in staggered positions

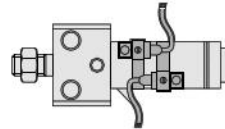

Sensor Switch Operating Range, Response Differential, and Maximum Sensing Location

● Operating range : ℓ

The distance the piston travels in one direction, while the switch is in the ON position.

● Response differential : C

The distance between the point where the piston turns the switch ON and the point where the switch is turned OFF as the piston travels in the opposite direction.

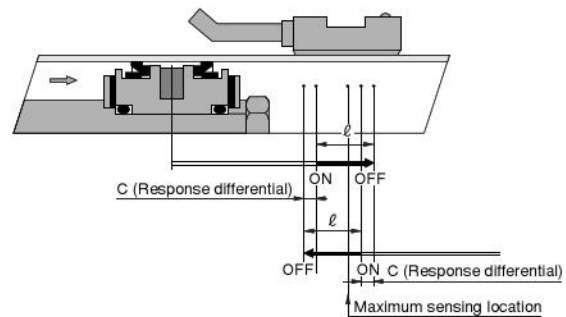

Item		mm [in.]						
Bore size		16 [0.630]	20 [0.787]	25 [0.984]	32 [1.260]	40 [1.575]	50 [1.969]	63 [2.480]
Operating range : ℓ	ZG530□	2.5~4.1	2.5~4.2	2.6~4.3	3.0~4.8	3.1~5.0	3.3~5.4	3.5~5.7
	ZG533□	[0.098~0.161]	[0.098~0.165]	[0.102~0.169]	[0.118~0.189]	[0.122~0.197]	[0.130~0.213]	[0.138~0.224]
	CS□M	6.7~7 [0.264~0.276]	7~8.5 [0.276~0.335]	7~8.5 [0.276~0.335]	8~9 [0.315~0.354]	9~10.5 [0.354~0.413]	7~8 [0.276~0.315]	8~9.5 [0.315~0.374]
	CS□F	—	7~8.5 [0.276~0.335]	8.5~10 [0.335~0.394]	9~10.5 [0.354~0.413]	10.5~12 [0.413~0.472]	9~10 [0.354~0.394]	9~10.5 [0.354~0.413]
Response differential : C	ZG530	0.7 [0.028] or less	0.7 [0.028] or less	0.8 [0.032] or less	0.7 [0.028] or less	0.8 [0.032] or less	0.8 [0.032] or less	0.8 [0.032] or less
	ZG533	0.7 [0.028] or less	0.7 [0.028] or less	0.8 [0.032] or less	0.7 [0.028] or less	0.8 [0.032] or less	0.8 [0.032] or less	0.8 [0.032] or less
	CS□M	1 [0.039] or less	1 [0.039] or less	1 [0.039] or less	1 [0.039] or less	1 [0.039] or less	1.2 [0.047] or less	1.2 [0.047] or less
	CS□F	—	1.5 [0.059] or less	1.5 [0.059] or less	1.5 [0.059] or less	1.5 [0.059] or less	2 [0.079] or less	1.5 [0.059] or less
Maximum sensing location	ZG530, ZG533 ^{Note 1}	11 [0.433]	11 [0.433]	11 [0.433]	11 [0.433]	11 [0.433]	11 [0.433]	11 [0.433]
	CS□M ^{Note 1}	11 [0.433]	11 [0.433]	11 [0.433]	11 [0.433]	11 [0.433]	11 [0.433]	11 [0.433]
	CS□F ^{Note 2}	—	16 [0.630]	16 [0.630]	16 [0.630]	16 [0.630]	16 [0.630]	16 [0.630]

Remark : Figures in the table above are reference values.

Notes: 1. Figures are from the end surface that is opposite to the lead wires.

2. Figures are from the end surface of the connector side.

Mounting Location of End of Stroke Detection Sensor Switch

When the sensor switch is mounted in the location shown in the diagram below (figures in the table are reference values), the magnet comes to the maximum sensing location of the sensor switch at the end of the stroke.

● Double acting cylinder

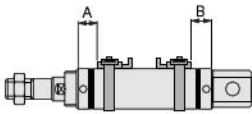

		mm [in.]					
Sensor switch model	Bore size	Double acting cylinder					
	Code	20	32	32	40	50	63
ZG530□ ZG553□	A	37 [1.456]	37 [1.456]	37 [1.456]	38.5 [1.516]	45 [1.772]	45 [1.772]
	B	27 [1.063]	27 [1.063]	27 [1.063]	27 [1.063]	36 [1.417]	36 [1.417]
CS□M	A	37 [1.456]	37 [1.456]	37 [1.456]	38.5 [1.516]	45 [1.772]	45 [1.772]
	B	27 [1.063]	27 [1.063]	27 [1.063]	27 [1.063]	36 [1.417]	36 [1.417]
CS□F	A	32 [1.260]	32 [1.260]	32 [1.260]	32 [1.260]	41 [1.614]	41 [1.614]
	B	22 [0.866]	22 [0.866]	22 [0.866]	22 [0.866]	32 [1.260]	32 [1.260]

● Block cylinder

● Side mount

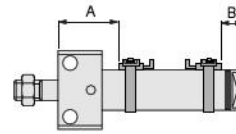

● Front mount

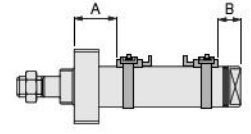

		mm [in.]													
Mounting type	Bore size	Side mount						Front mount							
		16	20	25	32	40	50	63	16	20	25	32	40	50	63
ZG530□ ZG553□	A Rod side	42 [1.654]	53 [2.087]	55 [2.165]	61 [2.402]	71 [2.796]	81 [3.189]	81 [3.189]	33 [1.299]	37 [1.457]	37 [1.457]	37 [1.457]	39 [1.536]	47 [1.850]	47 [1.850]
	B Rod side	16 [0.630]	20 [0.787]	20 [0.787]	21 [0.827]	25 [0.984]	45 [1.772]	45 [1.772]	16 [0.630]	20 [0.787]	20 [0.787]	21 [0.827]	25 [0.984]	45 [1.772]	45 [1.772]
CS□M	A Rod side	42 [1.654]	53 [2.087]	55 [2.165]	61 [2.402]	71 [2.796]	80 [3.150]	80 [3.150]	33 [1.299]	37 [1.457]	37 [1.457]	37 [1.457]	39 [1.536]	46 [1.811]	46 [1.811]
	B Rod side	16 [0.630]	20 [0.787]	20 [0.787]	21 [0.827]	25 [0.984]	44 [1.732]	44 [1.732]	16 [0.630]	20 [0.787]	20 [0.787]	21 [0.827]	25 [0.984]	44 [1.732]	44 [1.732]
CS□F	A Rod side	—	50 [1.969]	52 [2.047]	58 [2.283]	66 [2.598]	78 [3.071]	78 [3.071]	—	34 [1.339]	34 [1.339]	34 [1.339]	34 [1.339]	44 [1.732]	44 [1.732]
	B Rod side	—	17 [0.669]	17 [0.669]	18 [0.709]	20 [0.787]	42 [1.654]	42 [1.654]	—	17 [0.669]	17 [0.669]	18 [0.709]	22 [0.866]	42 [1.654]	42 [1.654]

Moving Sensor Switch

- ZG530
- ZG553
- CS M

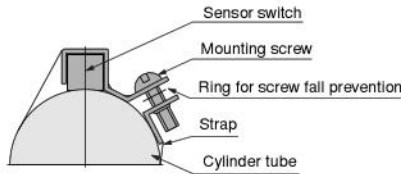

- Loosening the mounting screw allows the sensor switch to be moved freely along with the strap in the axial and circumferential direction. The sensor switch alone cannot be moved.
- To remove the sensor switch from the strap, first detach the strap from the cylinder tube and then remove the sensor switch from the strap.
- Tighten the mounting screw with a tightening torque of 49N·cm [4.3in·lbf] or less.

- CS F

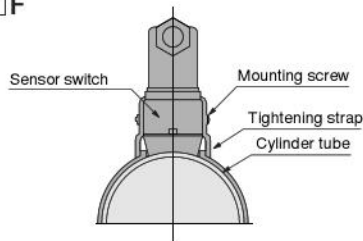

- Loosening the mounting screw allows the sensor switch to be moved freely in the axial and circumferential direction.
- Slightly loosening the mounting screw allows fine adjustment of the lead switch only, up to 5mm [0.197in.] in the axial direction. Tighten the mounting screw with a tightening torque of 68.6N·cm [6.1in·lbf] or less.

Dimensions of Sensor Switch mm [in.]

- ZG530
- ZG553
- CS M

Bore	Code	A	B
16	16	15	
[0.630]	[0.630]	[0.591]	
20	19	17	
[0.787]	[0.748]	[0.669]	
25	20.5	17.5	
[0.984]	[0.807]	[0.689]	
32	25	19	
[1.260]	[0.984]	[0.748]	
40	29	—*	
[1.575]	[1.142]		
50	34	—*	
[1.969]	[1.339]		
63	41	—*	
[2.480]	[1.614]		

※ At $\phi 40$ [1.575in.] or more, dimension B is the radius of the cylinder tube. Therefore, the protrusion in the B direction of the mounting section disappears.

$\phi 16$

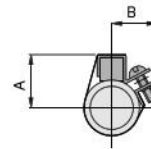

Lead wire length
A: 1000mm [39in.]
B: 3000mm [118in.]

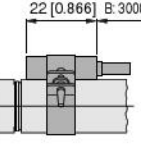

$\phi 20 \sim \phi 63$

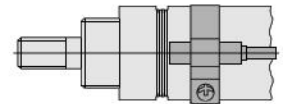
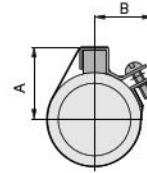

Lead wire length
A: 1000mm [39in.]
B: 3000mm [118in.]

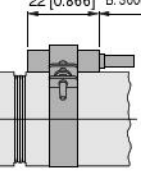

- CS F

Bore	Code	Y
20	59	
[0.787]	[2.323]	
25	61.5	
[0.984]	[2.421]	
32	65	
[1.260]	[2.559]	
40	69	
[1.575]	[2.717]	
50	76	
[1.969]	[2.992]	
63	83	
[2.480]	[3.268]	

