

Koganei Clean System products provide complete support for the maintenance of a clean environment inside the cleanroom.

Koganei Clean System products meet the needs of the ultra-clean production environment. In everything from actuators and valves to air preparation and auxiliary equipment, anti-corrosion materials processing and other Koganei-developed design concepts serve to prevent particle contamination within the cleanroom. These perfectly designed mechanisms, which resolve even the slightest leaks to the outside during operations, have already won a high level of reliability.

Koganei Cleanliness

There is currently no standard in JIS or elsewhere for methods of evaluating cleanliness for pneumatic equipment in the cleanroom specifications. Therefore, to measure the effects of cleanroom contamination by pneumatic equipment, Koganei has decided to use "number of particles generated per 10 operations," rather than particle density. Koganei has also developed classifications for application classes in cleanroom, based on JIS and other upper limit density tables, and on the company's own experience.



- Remarks:
1. In the above table, product performance in terms of the number of particles generated per 10 operations is expressed as the upper limit of particles corresponding to the equivalent JIS or ISO class.
 2. In the above table, values in the JIS, ISO, and FED-STD upper limit density tables are calculated as upper density per liter.
 3. The classes shown are clean levels as classified in JIS and ISO.

From the above definitions, the Koganei clean level classes can be viewed as the level of average contamination per liter of surrounding air over a period of 10 operations in cleanroom. Air ventilation in cleanrooms is usually faster than 1 cycle per minute, and clean volumetric capacity is usually larger than 1 liter, which should provide a sufficient safety margin in practice.

Caution: The above conclusions are based on an ideal situation in which air ventilation is being implemented. For specific cases where air ventilation is not ensured, caution is needed since the clean classes cannot be maintained.

The clean system diagrams shown here are for Class 5 equivalent products. For Class 4 or Class 3 equivalent products, consult us.

Evaluations of Cleanliness

Koganei has therefore specified its in-house measurement methods, to conduct evaluations on the cleanroom rating.

The number of particles of the Air Cylinder Cleanroom Specification is measured as shown in the method below.

1. Measurement conditions

1-1 Test circuit: Figure 1 (no suction), Figure 2 (with suction)

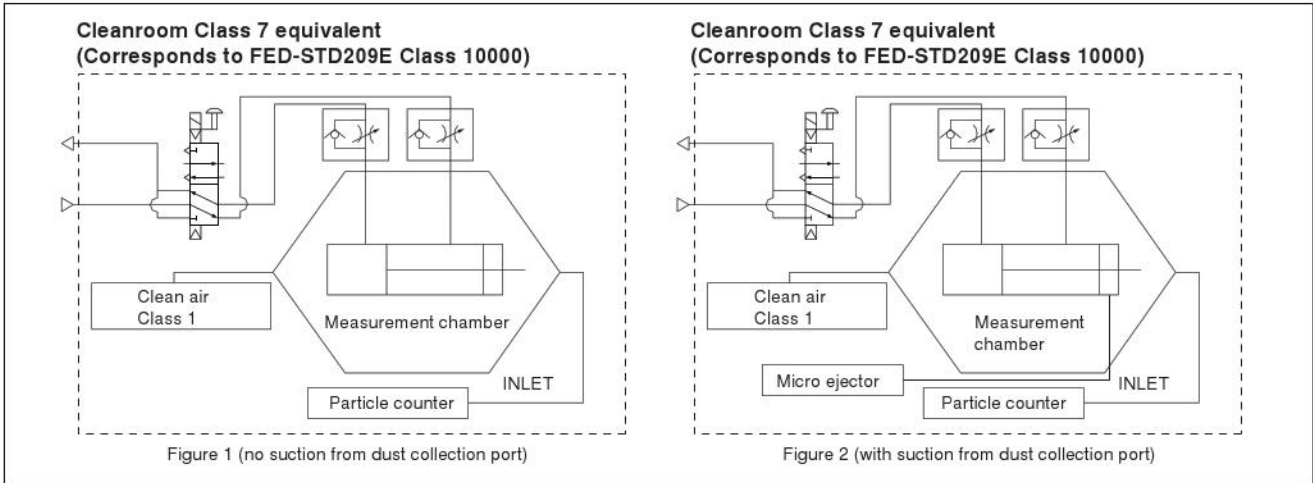

1-2 Operating conditions of tested cylinder

Operating frequency: 1Hz

Average speed: 500mm/s [20in./sec.]

Applied pressure: 0.5MPa [73psi.]

Suction condition: Microejector ME05, Primary side: 0.5MPa [73psi.] applied, Tube: $\phi 6$ [0.236in.]

Mounting direction: Vertical

Chamber volume: 8.3 ℓ [0.293ft³]

2. Particle counter

Manufacturer/model: RION/KM20

Suction flow rate: 28.3 ℓ /min [1ft³/min.]

Particle diameter: 0.1 μm , 0.2 μm , 0.3 μm , 0.5 μm , 0.7 μm , 1.0 μm

3. Measurement method

3-1 Confirmation of number of particles in the measurement system

Under the conditions in the above 1 and 2, using a particle counter to measure the sample for 9 minutes without operating the measurement sample, and confirmed the measured number of particle is 1 piece or less.

3-2 Measurement under operation

Under the conditions in the above 1 and 2, operating the measurement sample for 36 minutes, and measured the total values in the latter half of 18 minutes test.

3-3 Reconfirmation

Performed the measurement in 3-1 again, to reconfirm the number of particles in the measurement system.

4. Measurement results

● Cleanroom specification

Jig Cylinder (no suction from dust collection port)

Particle generation over 1 million operations (CS-CDA16 \times 30)

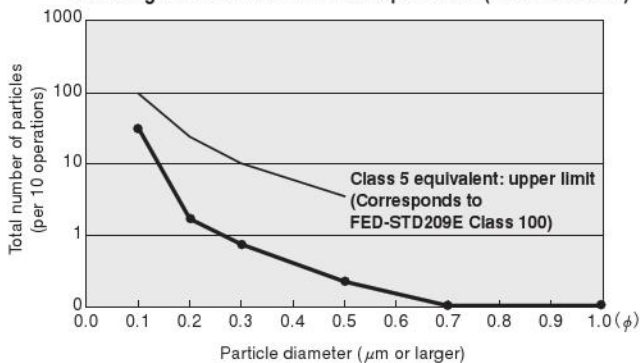

● Cleanroom specification

Slim Cylinder (with suction from dust collection port)

Particle generation over 1 million operations (CS-DA20 \times 100)

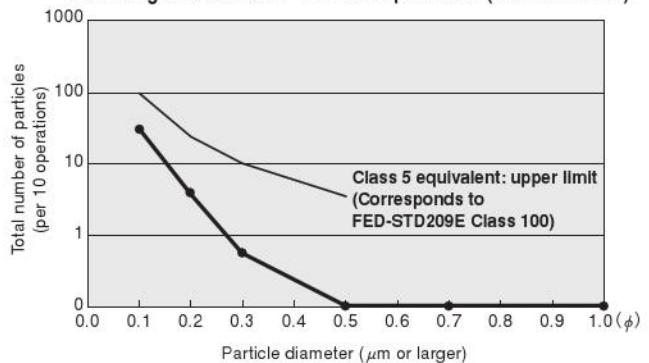

For "safety precautions" listed in the Clean System Product Drawings, see the materials below.

- For actuators, see "Safety Precautions" on p. 45 of the Actuators General Catalog .
- For valves, see "Safety Precautions" on p. 31 of the Valves General Catalog.
- For air treatment and auxiliary equipment, see "Safety Precautions" on p.31 of the General Catalog of Air Treatment, Auxiliary, Vacuum.

Inner Construction and Major Parts

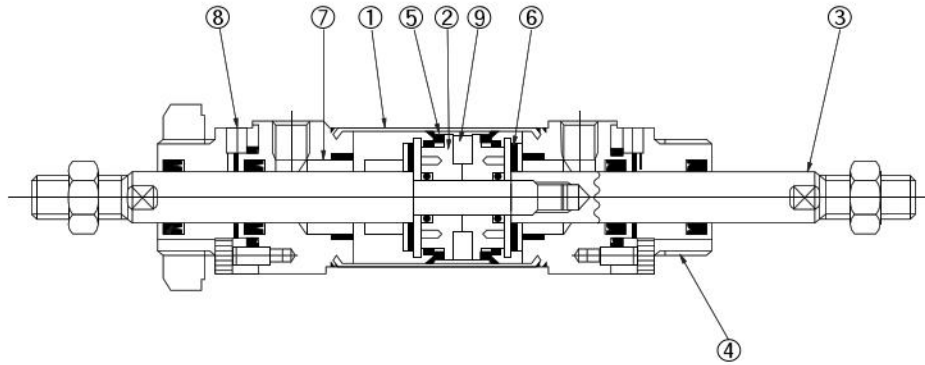

Major Parts and Materials

Parts	Bore size mm	20~40
①	Cylinder tube	Stainless steel
②	Piston	Plastic
③	Piston rod	Steel
④	Rod cover	Aluminum alloy (anodized)
⑤	Seal	Synthetic rubber (NBR)
⑥	Bumper	Synthetic rubber (NBR)
⑦	Rod bushing	Plastic
⑧	Dust prevention cover	Aluminum (anodized)
⑨	Magnet	Plastic magnet
	Mounting bracket	Mild steel (nickel plated)

Seals

Parts	Rod seal	Piston seal	Dust leak prevention seal
Bore mm	Quantity	2	2
20	NY-12×8×3.5	PPY-20	NY-12×8×3.5
25	NY-14×10×3.5	PPY-25	NY-14×10×3.5
32	NY-17×12×4	PPY-32	NY-17×12×4
40	NY-22×16×5	PPY-40	NY-22×16×5

Mass

Bore size mm [in.]	Zero stroke mass			Additional mass for each 1mm [0.0394in.] stroke	Mass of knuckle	
	Basic type	Foot mounting type	Flange mounting type		Y type knuckle	I type knuckle
20 [0.787]	190 [6.70]	330 [11.64]	270 [9.52]	1.2 [0.042]	41 [1.45]	36 [1.27]
25 [0.984]	290 [10.23]	450 [15.87]	370 [13.05]	1.6 [0.056]	75 [2.65]	70 [2.47]
32 [1.260]	430 [15.17]	620 [21.87]	530 [18.69]	2.5 [0.088]	75 [2.65]	70 [2.47]
40 [1.575]	630 [22.22]	920 [32.45]	760 [26.81]	3.9 [0.138]	120 [4.23]	132 [4.66]

Calculation example: For basic type of 40mm bore size and 100mm stroke
 $630 + (3.9 \times 100) = 1020\text{g}$ [35.98 oz.]

Dimensions mm [in.]

● Basic type

● $\phi 20 \sim \phi 40$ CS-DAD X

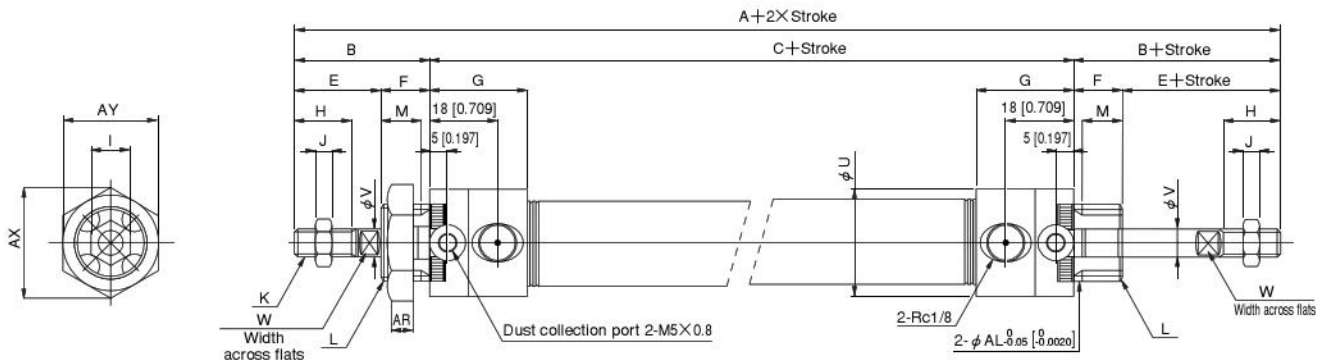

Bore	Code	A	B	C	E	F	G	H	I	J	K	L	M	U	V	W	AR	AX	AY	AL
20	[0.787]	166 [6.535]	35 [1.378]	96 [3.780]	23 [0.906]	12 [0.472]	26 [1.024]	15 [0.591]	12 [0.472]	5 [0.197]	M8 X 1	M20 X 1.5	10 [0.394]	27 [1.063]	8 [0.315]	6 [0.236]	7.5 [0.295]	31.2 [1.228]	27 [1.063]	26 [0.787]
25	[0.984]	176 [6.929]	40 [1.575]	96 [3.780]	26 [1.024]	14 [0.551]	26 [1.024]	18 [0.709]	14 [0.551]	6 [0.236]	M10 X 1.25	M22 X 1.5	12 [0.472]	29 [1.142]	10 [0.394]	8 [0.315]	9.5 [0.374]	34.6 [1.362]	30 [1.181]	22 [0.866]
32	[1.260]	186 [7.323]	45 [1.772]	96 [3.780]	31 [1.220]	14 [0.551]	26 [1.024]	23 [0.906]	14 [0.551]	6 [0.236]	M10 X 1.25	M27 X 2	12 [0.472]	35 [1.378]	12 [0.472]	10 [0.394]	9.5 [0.374]	41.6 [1.638]	36 [1.417]	27 [1.063]
40	[1.575]	186 [7.323]	45 [1.772]	96 [3.780]	31 [1.220]	14 [0.551]	25 [0.984]	23 [0.906]	19 [0.748]	8 [0.315]	M14 X 1.5	M33 X 2	12 [0.472]	41.6 [1.638]	16 [0.630]	14 [0.551]	9.5 [0.374]	47.3 [1.862]	41 [1.614]	33 [1.299]

● Foot mounting type

● $\phi 20 \sim \phi 40$ CS-DAD X -1

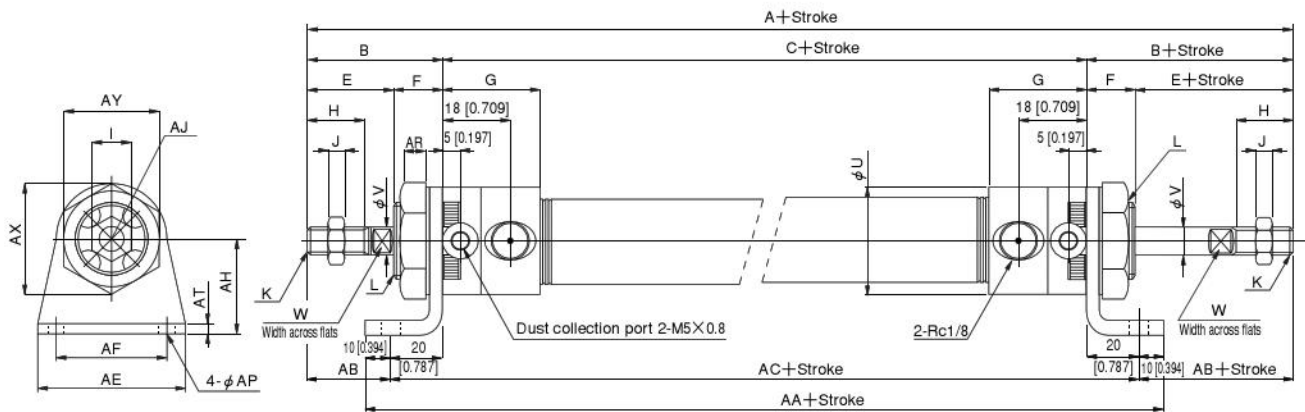

Bore	Code	A	B	C	E	F	G	H	I	J	K	L	U	V	W
20	[0.787]	166 [6.535]	35 [1.378]	96 [3.780]	23 [0.906]	12 [0.472]	26 [1.024]	15 [0.591]	12 [0.472]	5 [0.197]	M8 X 1	M20 X 1.5	27 [1.063]	8 [0.315]	6 [0.236]
25	[0.984]	176 [6.929]	40 [1.575]	96 [3.780]	26 [1.024]	14 [0.551]	26 [1.024]	18 [0.709]	14 [0.551]	6 [0.236]	M10 X 1.25	M22 X 1.5	29 [1.142]	10 [0.394]	8 [0.315]
32	[1.260]	186 [7.323]	45 [1.772]	96 [3.780]	31 [1.220]	14 [0.551]	26 [1.024]	23 [0.906]	14 [0.551]	6 [0.236]	M10 X 1.25	M27 X 2	35 [1.378]	12 [0.472]	10 [0.394]
40	[1.575]	186 [7.323]	45 [1.772]	96 [3.780]	31 [1.220]	14 [0.551]	25 [0.984]	23 [0.906]	19 [0.748]	8 [0.315]	M14 X 1.5	M33 X 2	41.6 [1.638]	16 [0.630]	14 [0.551]

Bore	Code	AA	AB	AC	AE	AF	AH	AJ	AP	AR	AT	AX	AY
20	[0.787]	156 [6.142]	15 [0.591]	136 [5.354]	55 [2.165]	40 [1.575]	25 [0.984]	15.5 [0.610]	6.8 [0.268]	7.5 [0.295]	3.2 [0.126]	31.2 [1.228]	27 [1.063]
25	[0.984]	156 [6.142]	20 [0.787]	136 [5.354]	55 [2.165]	40 [1.575]	30 [1.181]	17 [0.669]	6.8 [0.268]	9.5 [0.374]	3.2 [0.126]	34.6 [1.362]	30 [1.181]
32	[1.260]	156 [6.142]	25 [0.984]	136 [5.354]	55 [2.165]	40 [1.575]	35 [1.378]	20 [0.787]	6.8 [0.268]	9.5 [0.374]	3.2 [0.126]	41.6 [1.638]	36 [1.417]
40	[1.575]	156 [6.142]	25 [0.984]	136 [5.354]	75 [2.953]	55 [2.165]	40 [1.575]	23.5 [0.925]	9 [0.354]	9.5 [0.374]	4 [0.157]	47.3 [1.862]	41 [1.614]

Dimensions of Flange Mounting Type mm [in.]

● $\phi 20 \sim \phi 40$ CS-DAD X -3

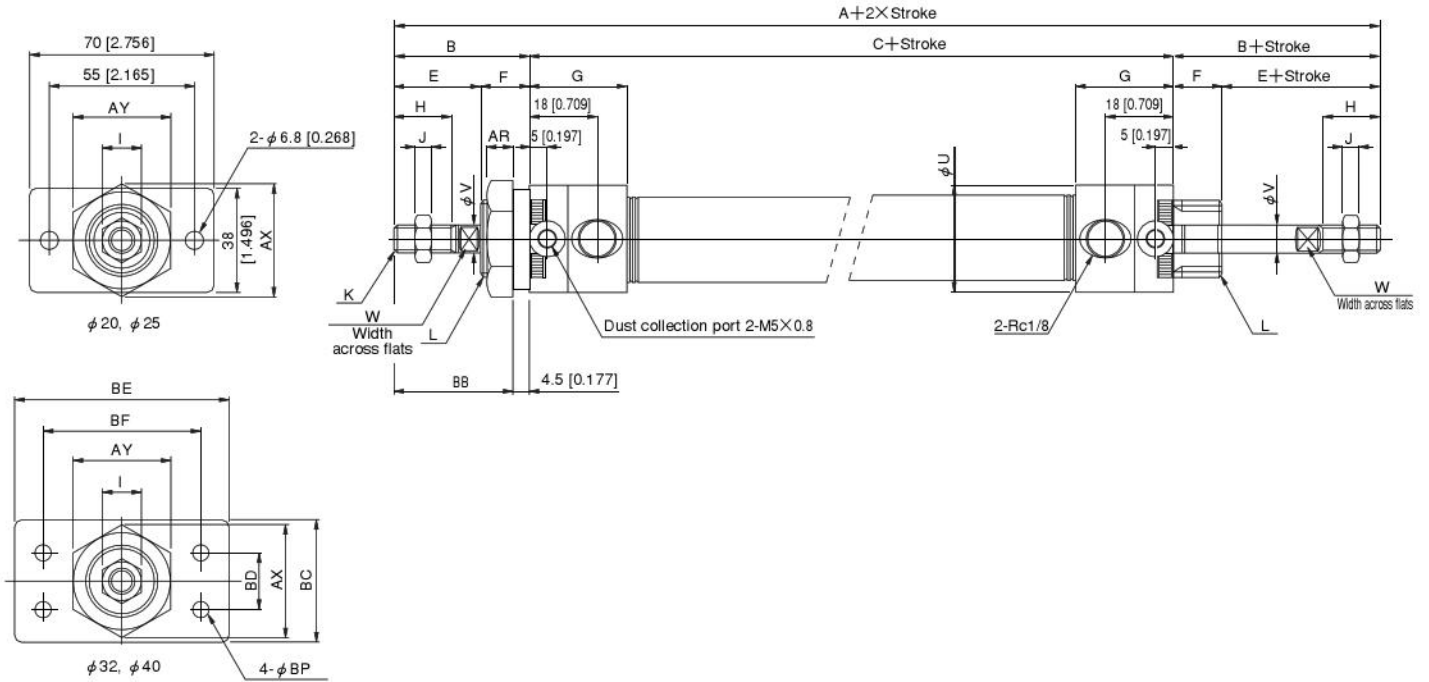

Bore	Code	A	B	C	E	F	G	H	I	J	K	L	U	V	W	AR	AX	AY	BB	BC	BD	BE	BF	BP
20	[0.787]	166 [6.535]	35 [1.378]	96 [3.780]	23 [0.906]	12 [0.472]	26 [1.024]	15 [0.591]	12 [0.472]	5 [0.197]	M8 X 1	M20 X 1.5	27 [1.063]	8 [0.315]	6 [0.236]	7.5 [0.295]	31.2 [1.228]	27 [1.063]	30.5 [1.201]	—	—	—	—	—
25	[0.984]	176 [6.929]	40 [1.575]	96 [3.780]	26 [1.024]	14 [0.551]	26 [1.024]	18 [0.709]	14 [0.551]	6 [0.236]	M10 X 1.25	M22 X 1.5	29 [1.142]	10 [0.394]	8 [0.315]	9.5 [0.374]	34.6 [1.362]	30 [1.181]	35.5 [1.398]	—	—	—	—	—
32	[1.260]	186 [7.323]	45 [1.772]	96 [3.780]	31 [1.220]	14 [0.551]	26 [1.024]	23 [0.906]	14 [0.551]	6 [0.236]	M10 X 1.25	M27 X 2	35 [1.378]	12 [0.472]	10 [0.394]	9.5 [0.374]	41.6 [1.638]	36 [1.417]	40.5 [1.594]	45 [1.772]	20 [0.787]	80 [3.150]	60 [2.362]	6.8 [0.268]
40	[1.575]	186 [7.323]	45 [1.772]	96 [3.780]	31 [1.220]	14 [0.551]	25 [0.984]	23 [0.906]	19 [0.748]	8 [0.315]	M14 X 1.5	M33 X 2	41.6 [1.638]	16 [0.630]	14 [0.551]	9.5 [0.374]	47.3 [1.862]	41 [1.614]	40.5 [1.594]	50 [1.969]	30 [1.181]	100 [3.937]	80 [3.150]	9 [0.354]

SLIM CYLINDERS

Sensor Switches

- Since a magnet comes standard in the Slim cylinders series, mounting a sensor switch will enable use in sensor switch applications.

Symbol



Order Codes

● Order codes for sensor switch with mounting strap



Lead wire length
(Applies to all except CS□F)
A — 1000mm [39in.]
B — 3000mm [118in.]

Cylinder basic type
DA — Excluding DAB ϕ 16 and DABK ϕ 16
DAB — For block cylinder ϕ 16
DABK — For block type end keep cylinder ϕ 16
S — For sensor switch type CS□F

Bore size Note

- 16 — ϕ 16 [0.630in.]
 - 20 — ϕ 20 [0.787in.]
 - 25 — ϕ 25 [0.984in.]
 - 32 — ϕ 32 [1.260in.]
 - 40 — ϕ 40 [1.575in.]
 - 50 — ϕ 50 [1.969in.]
 - 63 — ϕ 63 [2.480in.]
- Note: ϕ 50 and ϕ 63 are DA type only.

Sensor switch

- ZG530 — 2-lead wire Solid state type with indicator lamp DC10~28V
- ZG553 — 3-lead wire Solid state type with indicator lamp DC4.5~28V
- CS3M — 2-lead wire Reed switch type with indicator lamp DC10~30V, AC85~230V
- CS4M — 2-lead wire Reed switch type with indicator lamp DC10~30V, AC85~115V
- CS5M — 2-lead wire Reed switch type without indicator lamp DC3~30V, AC85~115V
- CS2F — 2-lead wire Reed switch type with indicator lamp AC85~230V
- CS3F — 2-lead wire Reed switch type with indicator lamp DC10~30V
- CS4F — 2-lead wire Reed switch type with indicator lamp DC10~30V
- CS5F — 2-lead wire Reed switch type without indicator lamp DC3~30V

● For details of sensor switches, see p.111~121.

Clean system product

● Order codes for sensor switch only



Lead wire length
(Applies to all except CS□F)
A — 1000mm [39in.]
B — 3000mm [118in.]

Sensor switch

- ZG530 — 2-lead wire Solid state type with indicator lamp DC10~28V
- ZG553 — 3-lead wire Solid state type with indicator lamp DC4.5~28V
- CS3M — 2-lead wire Reed switch type with indicator lamp DC10~30V, AC85~230V
- CS4M — 2-lead wire Reed switch type with indicator lamp DC10~30V, AC85~115V
- CS5M — 2-lead wire Reed switch type without indicator lamp DC3~30V, AC85~115V
- CS2F — 2-lead wire Reed switch type with indicator lamp AC85~230V
- CS3F — 2-lead wire Reed switch type with indicator lamp DC10~30V
- CS4F — 2-lead wire Reed switch type with indicator lamp DC10~30V
- CS5F — 2-lead wire Reed switch type without indicator lamp DC3~30V

● For details of sensor switches, see p.111~121.

Clean system product

● Order codes for mounting strap only

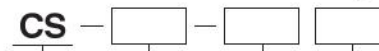

Bore size Note

- 16 — ϕ 16 [0.630in.]
 - 20 — ϕ 20 [0.787in.]
 - 25 — ϕ 25 [0.984in.]
 - 32 — ϕ 32 [1.260in.]
 - 40 — ϕ 40 [1.575in.]
 - 50 — ϕ 50 [1.969in.]
 - 63 — ϕ 63 [2.480in.]
- Note: ϕ 50 and ϕ 63 are DA type only.

Cylinder basic type

- DA — Excluding DAB ϕ 16 and DABK ϕ 16
- DAB — For block cylinder DAB ϕ 16
- DABK — For block end keep cylinder DABK ϕ 16
- S — For sensor switch type CS□F

Mounting strap type

- G5 — Solid state type
For ZG5□□
- Reed switch type
For CS□M
- F — Reed switch type
For CS□F

Clean system product

Minimum Cylinder Strokes When Using Sensor Switches

Sensor switch model	Bore size	mm [in.]		
		2 pcs. mounting		1 pc. mounting
		In-line	In staggered positions	
ZG530	16 [0.630]	20 [0.787]	10 [0.394]	10 [0.394]
ZG553	20~63 [0.787~2.480]	20 [0.787]	10 [0.394]	10 [0.394]
CS□M	16~63 [0.630~2.480]	20 [0.787]	15 [0.591]	15 [0.591]
CS□F	20~63 [0.787~2.480]	40 [1.575]	21 [0.827]	15 [0.591]

● Two pieces mounting ● One piece mounting

● When mounted in-line

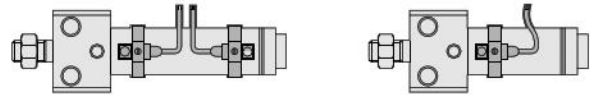

● When mounted in staggered positions

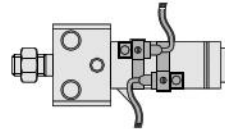

Sensor Switch Operating Range, Response Differential, and Maximum Sensing Location

● Operating range : ℓ

The distance the piston travels in one direction, while the switch is in the ON position.

● Response differential : C

The distance between the point where the piston turns the switch ON and the point where the switch is turned OFF as the piston travels in the opposite direction.

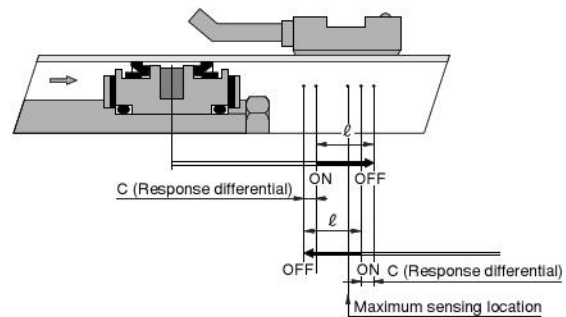

Item		Bore size							mm [in.]
		16 [0.630]	20 [0.787]	25 [0.984]	32 [1.260]	40 [1.575]	50 [1.969]	63 [2.480]	
Operating range : ℓ	ZG530□	2.5~4.1	2.5~4.2	2.6~4.3	3.0~4.8	3.1~5.0	3.3~5.4	3.5~5.7	
	ZG533□	[0.098~0.161]	[0.098~0.165]	[0.102~0.169]	[0.118~0.189]	[0.122~0.197]	[0.130~0.213]	[0.138~0.224]	
	CS□M	6.7~7 [0.264~0.276]	7~8.5 [0.276~0.335]	7~8.5 [0.276~0.335]	8~9 [0.315~0.354]	9~10.5 [0.354~0.413]	7~8 [0.276~0.315]	8~9.5 [0.315~0.374]	
	CS□F	—	7~8.5 [0.276~0.335]	8.5~10 [0.335~0.394]	9~10.5 [0.354~0.413]	10.5~12 [0.413~0.472]	9~10 [0.354~0.394]	9~10.5 [0.354~0.413]	
Response differential : C	ZG530	0.7 [0.028] or less	0.7 [0.028] or less	0.8 [0.032] or less	0.7 [0.028] or less	0.8 [0.032] or less	0.8 [0.032] or less	0.8 [0.032] or less	
	ZG533	0.7 [0.028] or less	0.7 [0.028] or less	0.8 [0.032] or less	0.7 [0.028] or less	0.8 [0.032] or less	0.8 [0.032] or less	0.8 [0.032] or less	
	CS□M	1 [0.039] or less	1 [0.039] or less	1 [0.039] or less	1 [0.039] or less	1 [0.039] or less	1.2 [0.047] or less	1.2 [0.047] or less	
	CS□F	—	1.5 [0.059] or less	1.5 [0.059] or less	1.5 [0.059] or less	1.5 [0.059] or less	2 [0.079] or less	1.5 [0.059] or less	
Maximum sensing location	ZG530, ZG533 ^{Note 1}	11 [0.433]	11 [0.433]	11 [0.433]	11 [0.433]	11 [0.433]	11 [0.433]	11 [0.433]	
	CS□M ^{Note 1}	11 [0.433]	11 [0.433]	11 [0.433]	11 [0.433]	11 [0.433]	11 [0.433]	11 [0.433]	
	CS□F ^{Note 2}	—	16 [0.630]	16 [0.630]	16 [0.630]	16 [0.630]	16 [0.630]	16 [0.630]	

Remark : Figures in the table above are reference values.

Notes: 1. Figures are from the end surface that is opposite to the lead wires.

2. Figures are from the end surface of the connector side.

Mounting Location of End of Stroke Detection Sensor Switch

When the sensor switch is mounted in the location shown in the diagram below (figures in the table are reference values), the magnet comes to the maximum sensing location of the sensor switch at the end of the stroke.

● Double acting cylinder

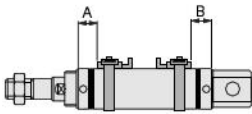

		mm [in.]					
Sensor switch model	Bore size	Double acting cylinder					
	Code	20	32	32	40	50	63
ZG530□ ZG553□	A	37 [1.456]	37 [1.456]	37 [1.456]	38.5 [1.516]	45 [1.772]	45 [1.772]
	B	27 [1.063]	27 [1.063]	27 [1.063]	27 [1.063]	36 [1.417]	36 [1.417]
CS□M	A	37 [1.456]	37 [1.456]	37 [1.456]	38.5 [1.516]	45 [1.772]	45 [1.772]
	B	27 [1.063]	27 [1.063]	27 [1.063]	27 [1.063]	36 [1.417]	36 [1.417]
CS□F	A	32 [1.260]	32 [1.260]	32 [1.260]	32 [1.260]	41 [1.614]	41 [1.614]
	B	22 [0.866]	22 [0.866]	22 [0.866]	22 [0.866]	32 [1.260]	32 [1.260]

● Block cylinder

● Side mount

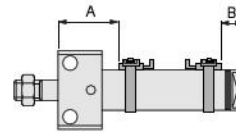

● Front mount

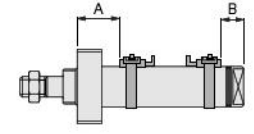

		mm [in.]													
Mounting type	Bore size	Side mount						Front mount							
		16	20	25	32	40	50	63	16	20	25	32	40	50	63
ZG530□ ZG553□	A Rod side	42 [1.654]	53 [2.087]	55 [2.165]	61 [2.402]	71 [2.796]	81 [3.189]	81 [3.189]	33 [1.299]	37 [1.457]	37 [1.457]	37 [1.457]	39 [1.536]	47 [1.850]	47 [1.850]
	B Rod side	16 [0.630]	20 [0.787]	20 [0.787]	21 [0.827]	25 [0.984]	45 [1.772]	45 [1.772]	16 [0.630]	20 [0.787]	20 [0.787]	21 [0.827]	25 [0.984]	45 [1.772]	45 [1.772]
CS□M	A Rod side	42 [1.654]	53 [2.087]	55 [2.165]	61 [2.402]	71 [2.796]	80 [3.150]	80 [3.150]	33 [1.299]	37 [1.457]	37 [1.457]	37 [1.457]	39 [1.536]	46 [1.811]	46 [1.811]
	B Rod side	16 [0.630]	20 [0.787]	20 [0.787]	21 [0.827]	25 [0.984]	44 [1.732]	44 [1.732]	16 [0.630]	20 [0.787]	20 [0.787]	21 [0.827]	25 [0.984]	44 [1.732]	44 [1.732]
CS□F	A Rod side	—	50 [1.969]	52 [2.047]	58 [2.283]	66 [2.598]	78 [3.071]	78 [3.071]	—	34 [1.339]	34 [1.339]	34 [1.339]	34 [1.339]	44 [1.732]	44 [1.732]
	B Rod side	—	17 [0.669]	17 [0.669]	18 [0.709]	20 [0.787]	42 [1.654]	42 [1.654]	—	17 [0.669]	17 [0.669]	18 [0.709]	22 [0.866]	42 [1.654]	42 [1.654]

Moving Sensor Switch

- ZG530
- ZG553
- CS M

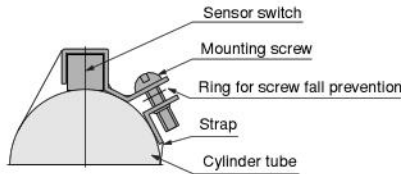

- Loosening the mounting screw allows the sensor switch to be moved freely along with the strap in the axial and circumferential direction. The sensor switch alone cannot be moved.
- To remove the sensor switch from the strap, first detach the strap from the cylinder tube and then remove the sensor switch from the strap.
- Tighten the mounting screw with a tightening torque of 49N·cm [4.3in·lbf] or less.

- CS F

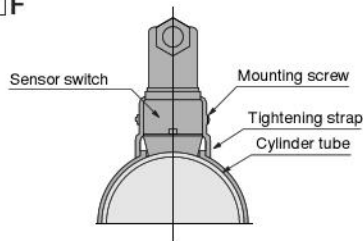

- Loosening the mounting screw allows the sensor switch to be moved freely in the axial and circumferential direction.
- Slightly loosening the mounting screw allows fine adjustment of the lead switch only, up to 5mm [0.197in.] in the axial direction. Tighten the mounting screw with a tightening torque of 68.6N·cm [6.1in·lbf] or less.

Dimensions of Sensor Switch mm [in.]

- ZG530
- ZG553
- CS M

Bore	Code	A	B
16	16	15	
[0.630]	[0.630]	[0.591]	
20	19	17	
[0.787]	[0.748]	[0.669]	
25	20.5	17.5	
[0.984]	[0.807]	[0.689]	
32	25	19	
[1.260]	[0.984]	[0.748]	
40	29	—*	
[1.575]	[1.142]		
50	34	—*	
[1.969]	[1.339]		
63	41	—*	
[2.480]	[1.614]		

※ At $\phi 40$ [1.575in.] or more, dimension B is the radius of the cylinder tube. Therefore, the protrusion in the B direction of the mounting section disappears.

$\phi 16$

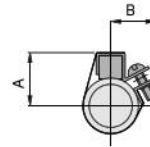

Lead wire length
A: 1000mm [39in.]
B: 3000mm [118in.]

22 [0.866]

$\phi 20 \sim \phi 63$

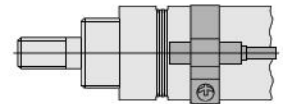
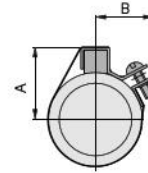

Lead wire length
A: 1000mm [39in.]
B: 3000mm [118in.]

22 [0.866]

- CS F

Bore	Code	Y
20	59	
[0.787]	[2.323]	
25	61.5	
[0.984]	[2.421]	
32	65	
[1.260]	[2.559]	
40	69	
[1.575]	[2.717]	
50	76	
[1.969]	[2.992]	
63	83	
[2.480]	[3.268]	

