

Low friction cylinders INDEX

RoHS directive compliant products

Features	32
Handling instructions and precautions	34
Low friction cylinders	
Specifications	36
Order codes	37
Internal configuration and names of each part	38
Dimensions	39
Clean specification low friction cylinder	
Specification	41
Order codes	42
Internal configuration and names of each part	43
Cleanliness evaluation	44
Dimensions	45
Mounting brackets	47
Sensor switch	49

JIG CYLINDERS C SERIES

Low friction cylinders

New C Series jig cylinders that provide both low pressure operation and low speed operation.

Minimum operating pressure from 0.01 MPa [1 psi], minimum operating speed of 1 mm/s [0.039 in/sec].

Low friction

Low sliding friction and reduced stick-slip following non-operation for improved response delay.

Support for pressing pressure control, tension control, etc.

Low-speed operation

1 mm/s [0.039 in/sec] minimum operating speed provides smooth operation with little stick-slip.

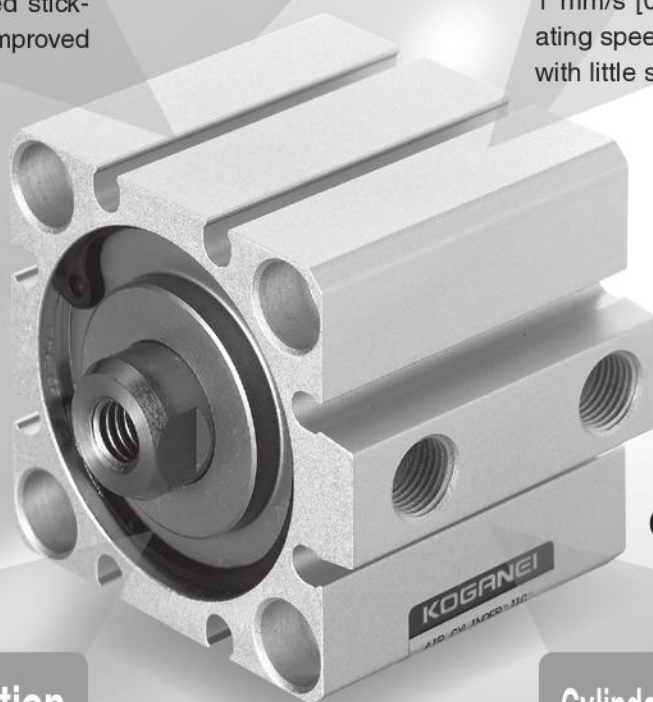

CDAZ

Low-pressure operation

Minimum operating pressure from 0.01 ~0.1 MPa [1~15 psi].

Cylinder bores from $\phi 6$ [0.236]

Bores from $\phi 6$ [0.236] to $\phi 40$ [1.575] meet a wide range of needs.

Cylinder bore mm [in]	Minimum operating pressure (MPa [psi])
6 [0.236]	0.1 [15]
8 [0.315]	0.06 [9]
10 [0.394]	0.03 [4]
12 [0.472]	0.03 [4]
16 [0.630]	0.02 [3]
20 [0.787]	0.02 [3]
25 [0.984]	0.02 [3]
32 [1.260]	0.01 [1]
40 [1.575]	0.01 [1]

(Measurement method: JIS B8377-1 standard)

The same applies to the clean specification.

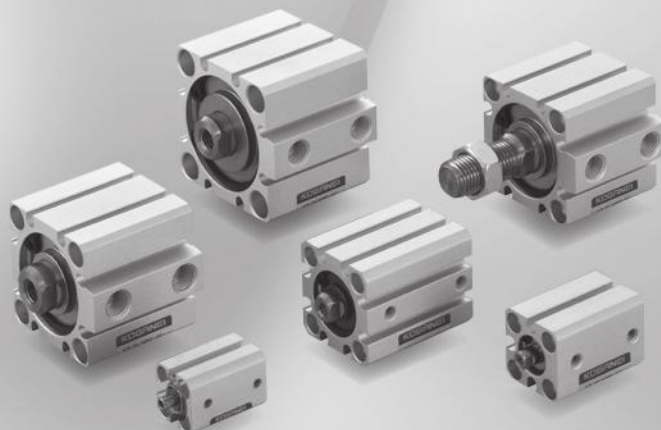

Clean specification low friction cylinders

JIS/ISO Class 4 equivalent cleanliness (FED-STD Class 10 equivalent)
clean specification also available (based on Koganei standards).



CS-CDAZ

Dust collection port

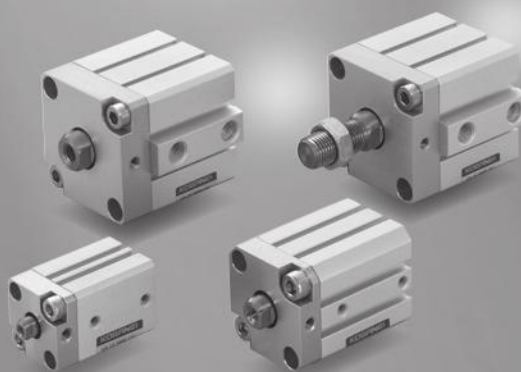

Low friction cylinders, clean specification low-friction cylinders

Bore size and stroke (mm [in])

Cylinder bore	Standard stroke											
6 [0.236]	5 [0.197]	10 [0.394]	15 [0.591]	20 [0.787]	—	—	—	—	—	—	—	—
8 [0.315]	5 [0.197]	10 [0.394]	15 [0.591]	20 [0.787]	—	—	—	—	—	—	—	—
10 [0.394]	5 [0.197]	10 [0.394]	15 [0.591]	20 [0.787]	—	—	—	—	—	—	—	—
12 [0.472]	5 [0.197]	10 [0.394]	15 [0.591]	20 [0.787]	25 [0.984]	30 [1.181]	—	—	—	—	—	—
16 [0.630]	5 [0.197]	10 [0.394]	15 [0.591]	20 [0.787]	25 [0.984]	30 [1.181]	—	—	—	—	—	—
20 [0.787]	5 [0.197]	10 [0.394]	15 [0.591]	20 [0.787]	25 [0.984]	30 [1.181]	35 [1.378]	40 [1.575]	45 [1.772]	50 [1.969]	—	—
25 [0.984]	5 [0.197]	10 [0.394]	15 [0.591]	20 [0.787]	25 [0.984]	30 [1.181]	35 [1.378]	40 [1.575]	45 [1.772]	50 [1.969]	—	—
32 [1.260]	5 [0.197]	10 [0.394]	15 [0.591]	20 [0.787]	25 [0.984]	30 [1.181]	35 [1.378]	40 [1.575]	45 [1.772]	50 [1.969]	75 [2.953]	100 [3.9]
40 [1.575]	5 [0.197]	10 [0.394]	15 [0.591]	20 [0.787]	25 [0.984]	30 [1.181]	35 [1.378]	40 [1.575]	45 [1.772]	50 [1.969]	75 [2.953]	100 [3.9]

CAUTION

- Be sure to thoroughly wash your hands following contact with the grease used for low friction cylinders and clean specification low friction cylinders. Grease on the hands can become heated when smoking and can cause grease to adhere to the cigarette, which creates the risk of noxious gas being emitted when the grease burns. Grease that is used on the outside is chemically very stable at normal temperatures, but generates noxious gas at temperatures above 260°C [500 °F]. Before use, be sure to read the safety precautions at the front of the general personal catalog.
- Low friction cylinders, clean specification low-friction cylinders are not non-ion specification.



General precautions

Air supply

1. Use air as the media. For the use of any other medium, consult your nearest Koganei sales office.
2. Air to operate the cylinder should be clean air that contains no degraded compressor oil, etc. Install an air filter (filtration of 40 μ m or less) near the cylinder or valve to remove dust and accumulated liquid. Also drain the air filter periodically. If liquid or dust gets into the cylinder, it may cause defective operation.

Piping

Before installing piping to the cylinder, thoroughly flush the inside of the pipes (with compressed air). Machining chips, sealing tape, rust and other debris remaining from the piping work may result in air leaks and malfunctions.

Atmosphere

1. Cover the unit when using it in locations where it might be subject to excessive dust, dripping water, dripping oil, etc.
2. This product cannot be used if the medium or ambient atmosphere includes any of the substances below. Organic solvents, phosphate type hydraulic oil, sulfur dioxide gas, chlorine gas, acids, or ozone.

Lubrication

Do not supply oil.

Bracket mounting

1. A foot bracket cannot be mounted on a low friction cylinder with spigot joint that has a cylinder bore of ϕ 40 [1.575] (-G). Cannot be mounted on a clean specification low friction cylinder with spigot joint (-G), of any cylinder bore.
2. A flange bracket cannot be mounted on the rod side of a low friction cylinder with spigot joint that has a cylinder bore of ϕ 40 [1.575] (-G). Cannot be mounted on the rod side of a clean specification low friction cylinder with spigot joint (-G), of any cylinder bore.
3. A clevis bracket cannot be mounted on a clean specification low friction cylinder.

Disassembly and assembly

Note the following before replacing a seal. Be sure to cut off all air supply completely, and confirm that residual pressure inside the product or in piping connected to the product is zero. To disassemble, remove the snap ring and then pull out the rod. The snap ring can fly off when it is being removed, so caution is required. Doing so creates the risk of injury.

The snap ring can fly off when it is being removed, so caution is required. A snap ring flying off creates the risk of material damage. When assembling, check to make sure that the snap ring is engaged securely. Incomplete assembly results in a dangerous situation that creates the risk of material damage and life-threatening injury.

Mid-stroke

- The mid-stroke manufacturing method basically uses tube cutting.
However, strokes up to 5 mm [0.197 in] with cylinder bores of ϕ 12 [0.472] to ϕ 40 [1.575] use collar stoppers.
 ϕ 6 [0.236], ϕ 8 [0.315], and ϕ 10 [0.394] cylinder bore mid-strokes are special handling (collar stoppers). Contact your nearest Koganei sales office for information about availability.
- Dimensions
 1. In the case of tube cutting, the add stroke is the mid-stroke.
 2. For the add stroke in the case of a collar stopper, the longer stroke becomes the standard stroke.

Sensor switch

Standard cylinders do not have a sensor switch magnet built in. To mount a sensor switch, a sensor cylinder with a built-in sensor switch magnet is required.

- Note
1. For information about the sensor switch mounting position and movement range, refer to page 25.
 2. Contact protection measures are required for connections that result in an inductive load on a reed sensor switch, or when capacitance surge is generated. For details about contact protection measures, refer to the sensor switch page of the general personal catalog.

Other

1. Avoid use that subjects the piston rod to lateral load.
2. Minimum operating pressure is measured based on JIS B8377-1.
Measurement Method Summary: With no load, horizontal mounting, a minimum operating pressure is applied to each size cylinder and then stopped. A full stroke is performed to check for vibration or any other abnormality.

Handling instructions and precautions



Piping and mounting

Piping

Refer to the diagrams below in the case of low-speed operation of a low friction cylinder.

Recommended circuit

1. Basic circuit

Uses meter out speed controller.

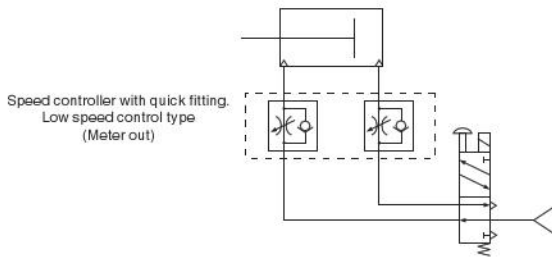

2. Rod pop-out prevention circuit

Using the cylinder in combination with the speed controller shown in the following diagram is effective for controlling speed and preventing runaway operations.

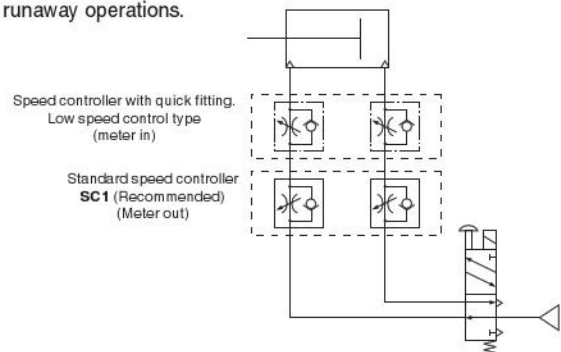

Note: Install the speed controller as close as possible to the cylinder.

Installing the main unit

To allow for a variety of possible mounting methods, the jig cylinder mounting holes are available as a combination of female threaded holes and as through holes, or as female threaded holes only.

For details, refer to the diagrams below. The mounting method is the same regardless of the cylinder bore.

Note: When fixing the main unit with direct through bolts, be sure to use the attached special washers (not included with $\phi 6$ [0.236], $\phi 8$ [0.315], $\phi 10$ [0.394] cylinder bores).

● Low friction cylinders

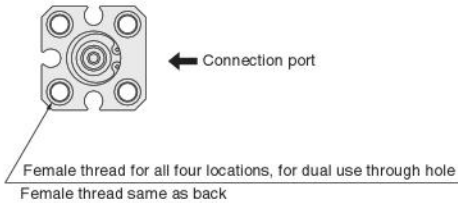

● Clean specification low friction cylinders

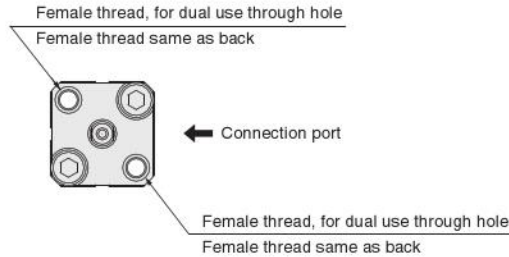

* The head side (back surface) has dual use female thread/through holes at two locations. The other two locations are female thread only.

Thrust

Determine the thrust required by the load and working air pressure, then select the appropriate cylinder bore.

The table shows calculated values, so select a cylinder bore whose load factor ($\text{Load Factor} = \frac{\text{Load}}{\text{Calculated value}}$) that is 70% or lower (50% or lower in the case of high speed).

● Double acting type

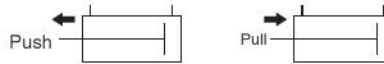

Cylinder bore mm [in]	Piston Rod diameter mm [in]	Operation	Pressure area mm ²	Air pressure MPa [psi]							N [lbf]
				0.1 [15]	0.2 [29]	0.3 [44]	0.4 [58]	0.5 [73]	0.6 [87]	0.7 [102]	
6 [0.236]	4 [0.157]	Push side	28.3 [0.044]	2.8 [0.629]	5.7 [1.281]	8.5 [1.911]	11.3 [2.540]	14.1 [3.170]	17.0 [3.822]	19.8 [4.451]	
		Pull side	15.7 [0.024]	1.6 [0.360]	3.1 [0.697]	4.7 [1.057]	6.3 [1.416]	7.9 [1.776]	9.4 [2.113]	11.0 [2.473]	
8 [0.315]	5 [0.197]	Push side	50.3 [0.078]	5.0 [1.124]	10.1 [2.271]	15.1 [3.395]	20.1 [4.519]	25.1 [5.643]	30.2 [6.789]	35.2 [7.913]	
		Pull side	30.6 [0.047]	3.1 [0.697]	6.1 [1.371]	9.2 [2.068]	12.3 [2.765]	15.3 [3.440]	18.4 [4.136]	21.4 [4.811]	
10 [0.394]	5 [0.197]	Push side	78.5 [0.122]	7.9 [1.776]	15.7 [3.530]	23.6 [5.305]	31.4 [7.059]	39.3 [8.835]	47.1 [10.589]	55.0 [12.364]	
		Pull side	58.9 [0.091]	5.9 [1.326]	11.8 [2.653]	17.7 [3.979]	23.6 [5.305]	29.5 [6.632]	35.3 [7.936]	41.2 [9.262]	
12 [0.472]	6 [0.236]	Push side	113.0 [0.2]	11.3 [2.540]	22.6 [5.081]	33.9 [7.621]	45.2 [10.161]	56.5 [12.702]	67.8 [15.242]	79.1 [17.782]	
		Pull side	84.8 [0.131]	8.5 [1.911]	17.0 [3.822]	25.4 [5.71]	33.9 [7.621]	42.4 [9.532]	50.9 [11.443]	59.3 [13.331]	
16 [0.630]	8 [0.315]	Push side	201.0 [0.3]	20.1 [4.519]	40.2 [9.037]	60.3 [13.556]	80.4 [18.075]	100.5 [22.6]	120.6 [27.1]	140.7 [31.6]	
		Pull side	150.0 [0.2]	15.1 [3.395]	30.1 [6.767]	45.2 [10.161]	60.3 [13.556]	75.4 [16.951]	90.4 [20.323]	105.5 [23.7]	
20 [0.787]	10 [0.394]	Push side	314.0 [0.5]	31.4 [7.059]	62.8 [14.118]	94.2 [21.177]	125.6 [28.2]	157.0 [35.3]	188.4 [42.4]	219.8 [49.4]	
		Pull side	235.5 [0.4]	23.6 [5.305]	47.1 [10.589]	70.7 [15.894]	94.2 [21.177]	117.8 [26.5]	141.3 [31.8]	164.9 [37.1]	
25 [0.984]	12 [0.472]	Push side	490.6 [0.8]	49.1 [11.038]	98.1 [22.054]	147.2 [33.1]	196.3 [44.1]	245.3 [55.1]	294.4 [66.2]	343.4 [77.2]	
		Pull side	377.6 [0.6]	37.8 [8.498]	75.5 [16.973]	113.3 [25.5]	151.0 [33.9]	188.8 [42.4]	226.6 [50.9]	264.3 [59.4]	
32 [1.260]	16 [0.630]	Push side	803.8 [1.2]	80.4 [18.075]	160.8 [36.1]	241.2 [54.2]	321.5 [72.3]	401.9 [90.4]	482.3 [108.4]	562.7 [126.5]	
		Pull side	602.9 [0.9]	60.3 [13.556]	120.6 [27.1]	180.9 [40.7]	241.2 [54.2]	301.4 [67.8]	361.7 [81.3]	422.0 [94.9]	
40 [1.575]	16 [0.630]	Push side	1256.0 [2]	125.6 [28.2]	251.2 [56.5]	376.8 [84.7]	502.4 [112.9]	628.0 [141.2]	753.6 [169.4]	879.2 [197.7]	
		Pull side	1055.0 [2]	105.5 [23.7]	211.0 [47.4]	316.5 [71.2]	422.0 [94.9]	527.5 [118.6]	633.0 [142.3]	738.5 [166.0]	

JIG CYLINDERS C SERIES LOW FRICTION CYLINDERS

Double Acting Type

Symbol

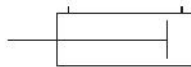

Specifications

Item	Cylinder bore mm [in]	6 [0.236]	8 [0.315]	10 [0.394]	12 [0.472]	16 [0.630]	20 [0.787]	25 [0.984]	32 [1.260]	40 [1.575]
Operating type		Double acting type								
Media		Air								
Maximum operating pressure	MPa [psi]	0.7 [102]								
Proof pressure	MPa [psi]	1.05 [152]								
Operating temperature range	°C [°F]	0 ~ 60 [32 ~ 140]								
Cushion		None			Rubber bumper type					
Lubrication		No								
Port size		M3×0.5			M5×0.8				Rc1/8	

Minimum operating pressure

Item	Cylinder bore mm [in]	6 [0.236]	8 [0.315]	10 [0.394]	12 [0.472]	16 [0.630]	20 [0.787]	25 [0.984]	32 [1.260]	40 [1.575]
Minimum operating pressure	MPa [psi]	0.1 [15]	0.06 [9]	0.03 [4]		0.02 [3]		0.01 [1]		

Operating speed range

Item	Cylinder bore mm [in]	6 [0.236]	8 [0.315]	10 [0.394]	12 [0.472]	16 [0.630]	20 [0.787]	25 [0.984]	32 [1.260]	40 [1.575]
Operating speed range	mm/s [in/sec]	1 ^{Note} ~ 500 [0.039 ~ 19.7]								

Note: When using ϕ 6 [0.236] at 1 mm/s [0.039 in/sec], apply air pressure of at least 0.3 MPa [44 psi].

When using ϕ 8 [0.315] to ϕ 40 [1.575] at 1 mm/s [0.039 in/sec], apply air pressure of at least 0.15 MPa [22 psi].

When using reed switch type sensor switches, operates at cylinder speed of 30 mm/s [1.181 in/sec] or higher.

Bore Size and Stroke

For information about mid-stroke, refer to page 34.

Operating type	Bore	Standard stroke	
		Standard cylinders	Cylinder with magnet
Double acting type	6 [0.236]	5 [0.197], 10 [0.394], 15 [0.591], 20 [0.787]	5 [0.197], 10 [0.394], 15 [0.591], 20 [0.787]
	8 [0.315]		
	10 [0.394]		
	12 [0.472]	5 [0.197], 10 [0.394], 15 [0.591], 20 [0.787], 25 [0.984], 30 [1.181]	5 [0.197], 10 [0.394], 15 [0.591], 20 [0.787], 25 [0.984], 30 [1.181]
	16 [0.630]	5 [0.197], 10 [0.394], 15 [0.591], 20 [0.787], 25 [0.984], 30 [1.181], 35 [1.378], 40 [1.575], 45 [1.772], 50 [1.969]	5 [0.197], 10 [0.394], 15 [0.591], 20 [0.787], 25 [0.984], 30 [1.181], 35 [1.378], 40 [1.575], 45 [1.772], 50 [1.969]
	20 [0.787]	5 [0.197], 10 [0.394], 15 [0.591], 20 [0.787], 25 [0.984], 30 [1.181], 35 [1.378], 40 [1.575], 45 [1.772], 50 [1.969]	5 [0.197], 10 [0.394], 15 [0.591], 20 [0.787], 25 [0.984], 30 [1.181], 35 [1.378], 40 [1.575], 45 [1.772], 50 [1.969]
	25 [0.984]	5 [0.197], 10 [0.394], 15 [0.591], 20 [0.787], 25 [0.984], 30 [1.181], 35 [1.378], 40 [1.575], 45 [1.772], 50 [1.969]	5 [0.197], 10 [0.394], 15 [0.591], 20 [0.787], 25 [0.984], 30 [1.181], 35 [1.378], 40 [1.575], 45 [1.772], 50 [1.969]
	32 [1.260]	5 [0.197], 10 [0.394], 15 [0.591], 20 [0.787], 25 [0.984], 30 [1.181], 35 [1.378], 40 [1.575], 45 [1.772], 50 [1.969], 75 [2.953], 100 [3.9]	5 [0.197], 10 [0.394], 15 [0.591], 20 [0.787], 25 [0.984], 30 [1.181], 35 [1.378], 40 [1.575], 45 [1.772], 50 [1.969], 75 [2.953], 100 [3.9]
40 [1.575]	5 [0.197], 10 [0.394], 15 [0.591], 20 [0.787], 25 [0.984], 30 [1.181], 35 [1.378], 40 [1.575], 45 [1.772], 50 [1.969], 75 [2.953], 100 [3.9]	5 [0.197], 10 [0.394], 15 [0.591], 20 [0.787], 25 [0.984], 30 [1.181], 35 [1.378], 40 [1.575], 45 [1.772], 50 [1.969], 75 [2.953], 100 [3.9]	

Reference 1: Stroke tolerance $^{+1}_{0}$ [0.039]

2: ϕ 6 [0.236], ϕ 8 [0.315], and ϕ 10 [0.394] cylinder bore mid-strokes are special handling (collar stoppers).

3: ϕ 12 [0.472] to ϕ 40 [1.575] cylinder bore mid-strokes basically are tube cut.

However, strokes up to 5 mm [0.197 in] with cylinder bores of ϕ 12 [0.472] to ϕ 40 [1.575] are not tube cut.

In this case, a collar stopper is used.

Order Codes for Low Friction Cylinders

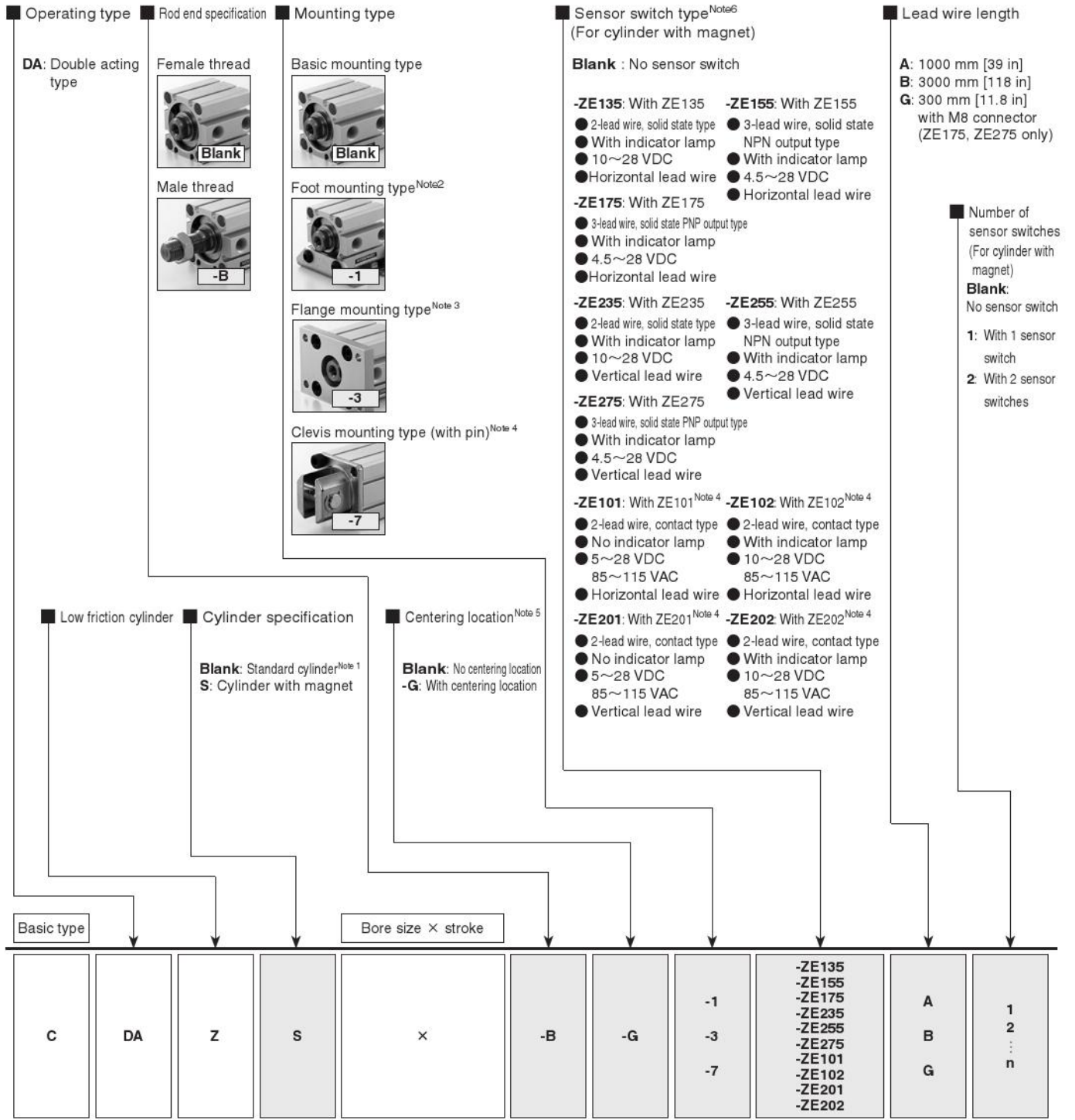

● See table for bore size and stroke.

● For details about cylinder joints for male thread and cylinder rod ends, refer to the general personal catalog.

● For the order number of a sensor switch only, see page 49.

Note 1: Low friction standard cylinders do not have a sensor switch magnet built in.

2: Cannot be mounted on a cylinder with spigot joint, which has a $\phi 40$ [1.575] cylinder bore (-G). Not available for cylinder bores $\phi 6$ [0.236], $\phi 8$ [0.315], or $\phi 10$ [0.394].

3: Cannot be mounted on the rod side of a cylinder with spigot joint, which has a $\phi 40$ [1.575] cylinder bore (-G). Not available for cylinder bores $\phi 6$ [0.236], $\phi 8$ [0.315], or $\phi 10$ [0.394].

4: Not available for cylinder bores $\phi 6$ [0.236], $\phi 8$ [0.315], or $\phi 10$ [0.394].

5: Not available for cylinder bores $\phi 6$ [0.236] to $\phi 12$ [0.472].

6: For details about sensor switches, see the general personal catalog.

● Mounting brackets are attached when shipped.

● When the stroke of a $\phi 12$ [0.472] or $\phi 16$ [0.630] foot bracket is less than 10 mm [0.394 in], it may be impossible to mount two sensor switches due to interference between the foot bracket and sensor switch. For details, contact your nearest Koganei sales office.

Additional Parts (To be ordered separately)



Foot mounting bracket (page 47)



Flange mounting bracket (page 48)



Clevis mounting bracket (page 48)

Inner Construction and Major Parts

● Double acting type (CDAZ)

● $\phi 6$ [0.236] ~ $\phi 10$ [0.394]

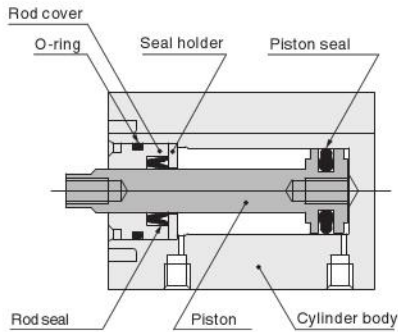

● $\phi 12$ [0.472] ~ $\phi 40$ [1.575]

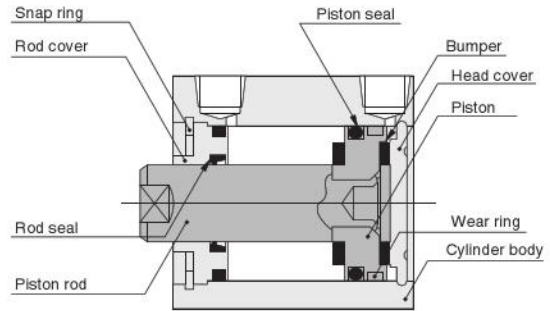

● Cylinder with magnet

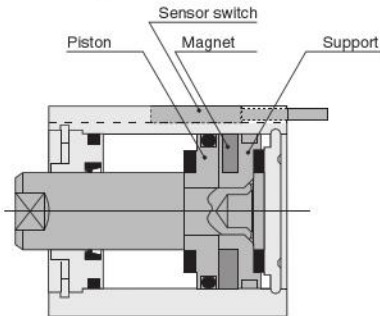

Major Parts and Materials

Article	Cylinder bore mm [in]	6 [0.236]	8 [0.315]	10 [0.394]	12 [0.472]	16 [0.630]	20 [0.787]	25 [0.984]	32 [1.260]	40 [1.575]	
Cylinder body		Aluminum alloy (anodized)									
Piston		Stainless steel		Aluminum alloy (special anti-rust treated)							
Piston rod		—			Stainless steel (with chrome plating)				Hard steel (with chrome plating)		
Gasket		Synthetic rubber (NBR)									
Rod cover		Aluminum alloy (special anti-abrasion treated)									
Bumper		—			Synthetic rubber (NBR)						
Magnet		Neodymium magnet				Plastic magnet					
Support		Copper alloy				Aluminum alloy (special anti-rust treated)					
Snap ring		—			Hard steel (phosphoric acid salt coating)						
Wear ring		—			Synthetic resin						

Seal Repair Kit

Bore mm [in]	Model	Set contents
12 [0.472]	SRK-CDAZ12	Piston seal: 1 Rod seal: 1 O-ring: 1
16 [0.630]	SRK-CDAZ16	
20 [0.787]	SRK-CDAZ20	
25 [0.984]	SRK-CDAZ25	
32 [1.260]	SRK-CDAZ32	
40 [1.575]	SRK-CDAZ40	

Note 1: There is no seal repair kit available for cylinder bores $\phi 6$ [0.236], $\phi 8$ [0.315], or $\phi 10$ [0.394].

2: Use special grease. For information about grease, contact Koganei.

Mass

Bore size mm [in]	Zero stroke Mass	Additional mass for each 1 mm stroke	Additional mass of cylinder with magnet	Mass of mounting brackets			Additional mass of sensor switch ^{Note}	
				Foot bracket	Flange bracket	Clevis bracket	ZE □□□ A ZE □□□ G	ZE □□□ B
6 [0.236]	10.3 [0.363]	0.74 [0.026]	3.9 [0.138]	—	—	—	15 [0.529]	35 [1.235]
8 [0.315]	13.9 [0.490]	0.95 [0.034]	5.4 [0.190]	—	—	—		
10 [0.394]	18.9 [0.667]	1.12 [0.040]	6.8 [0.240]	—	—	—		
12 [0.472]	28.3 [0.998]	1.28 [0.045]	8 [0.282]	50 [1.764]	55 [1.940]	30 [1.058]		
16 [0.630]	39.9 [1.407]	1.62 [0.057]	11 [0.388]	62 [2.187]	71 [2.504]	40 [1.411]		
20 [0.787]	66.1 [2.332]	2.26 [0.080]	27 [0.952]	84 [2.963]	101 [3.6]	75 [2.646]		
25 [0.984]	91.5 [3.228]	3.11 [0.110]	39 [1.376]	104 [3.7]	160 [5.6]	100 [3.5]		
32 [1.260]	140.1 [4.9]	4.11 [0.145]	28 [0.988]	126 [4.4]	186 [6.6]	165 [5.8]		
40 [1.575]	236.1 [8.3]	4.47 [0.158]	37 [1.305]	160 [5.6]	335 [11.8]	200 [7.1]		

Note: Sensor switch types A, B, and G are lead wire lengths. A: 1000 mm [39 in], B: 3000 mm [118 in], G: 300 mm [11.8 in], with M8 connector

Dimensions of Low Friction Double Acting Type (mm [in])

● $\phi 6 [0.236] \sim \phi 25 [0.984]$

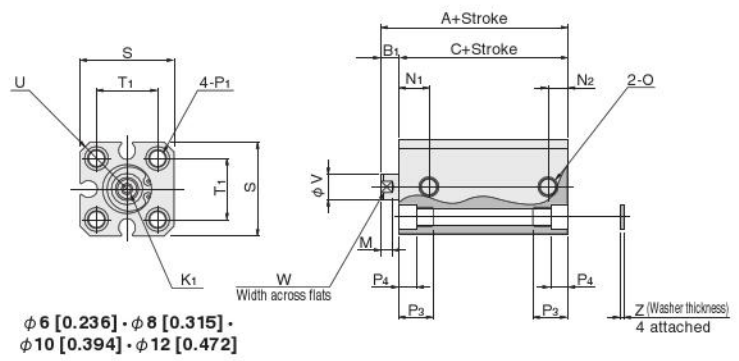
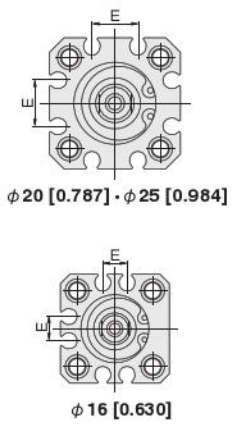
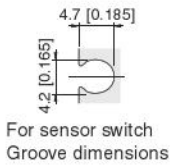

● Diagram shows $\phi 12 [0.472]$.

● $\phi 32 [1.260] \cdot \phi 40 [1.575]$

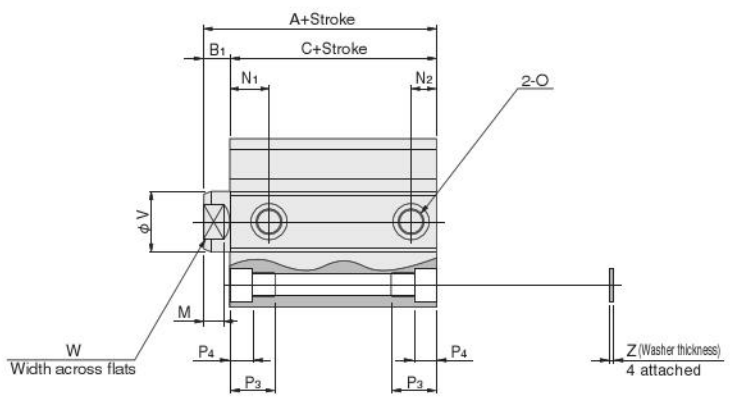
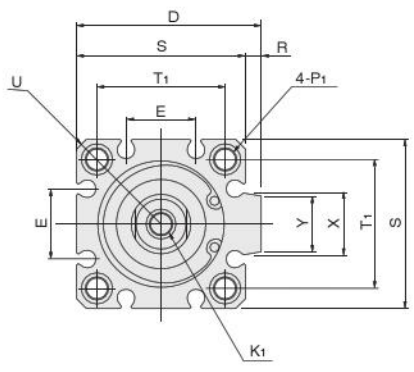
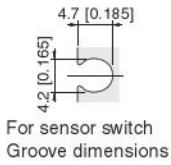

Model Bore Code	Standard cylinder (CDAZ)			Cylinder with magnet (CDAZS)			D	E	K ₁	M	N ₁	N ₂	O
	A	B ₁	C	A	B ₁	C							
6 [0.236]	19 [0.748]	5 [0.197]	14 [0.551]	24 [0.945]	5 [0.197]	19 [0.748]	—	—	M2.5 × 0.45, depth 5 [0.197]	3 [0.118]	6.5 [0.256]	3.5 [0.138]	M3 × 0.5
8 [0.315]	20 [0.787]	5 [0.197]	15 [0.591]	25 [0.984]	5 [0.197]	20 [0.787]	—	—	M3 × 0.5, depth 5 [0.197]	3 [0.118]	7.5 [0.295]	3.5 [0.138]	M3 × 0.5
10 [0.394]	21 [0.827]	5 [0.197]	16 [0.630]	26 [1.024]	5 [0.197]	21 [0.827]	—	—	M3 × 0.5, depth 5 [0.197]	3 [0.118]	8 [0.315]	4 [0.157]	M3 × 0.5
12 [0.472]	27 [1.063]	5 [0.197]	22 [0.866]	32 [1.260]	5 [0.197]	27 [1.063]	—	—	M3 × 0.5, depth 6 [0.236]	3.5 [0.138]	8 [0.315]	5 [0.197]	M5 × 0.8
16 [0.630]	27.5 [1.083]	5.5 [0.217]	22 [0.866]	32.5 [1.280]	5.5 [0.217]	27 [1.063]	—	6.2 [0.244]	M4 × 0.7, depth 8 [0.315]	3.5 [0.138]	8 [0.315]	5 [0.197]	M5 × 0.8
20 [0.787]	30 [1.181]	5.5 [0.217]	24.5 [0.965]	40 [1.575]	5.5 [0.217]	34.5 [1.358]	—	12.2 [0.480]	M5 × 0.8, depth 10 [0.394]	4.5 [0.177]	9.5 [0.374]	5 [0.197]	M5 × 0.8
25 [0.984]	32 [1.260]	6 [0.236]	26 [1.024]	42 [1.654]	6 [0.236]	36 [1.417]	—	12.2 [0.480]	M6 × 1, depth 10 [0.394]	5 [0.197]	10.5 [0.413]	5 [0.197]	M5 × 0.8
32 [1.260]	35 [1.378]	7 [0.276]	28 [1.102]	40 [1.575]	7 [0.276]	33 [1.299]	48.5 [1.909]	18.2 [0.717]	M8 × 1.25, depth 12 [0.472]	6 [0.236]	9.5 [0.374]	7.5 [0.295]	Rc1/8
40 [1.575]	38 [1.496]	7 [0.276]	31 [1.220]	43 [1.693]	7 [0.276]	36 [1.417]	56.5 [2.224]	18.2 [0.717]	M8 × 1.25, depth 12 [0.472]	6 [0.236]	10.5 [0.413]	7.5 [0.295]	Rc1/8

Bore Code	P ₁	P ₃	P ₄	R	S	T ₁	U	V	W	X	Y	Z	Applicable through bore
6 [0.236]	$\phi 3.3 [0.13]$ (through hole) counter bore $\phi 6 [0.236]$ (both sides) and M4 × 0.7 (both sides)	9.5 [0.374]	3.5 [0.138]	—	19 [0.748]	11 [0.433]	R12	4 [0.157]	3.5 [0.138]	—	—	—	M3
8 [0.315]	$\phi 3.3 [0.13]$ (through hole) counter bore $\phi 6.2 [0.244]$ (both sides) and M4 × 0.7 (both sides)	9.5 [0.374]	3.5 [0.138]	—	21 [0.827]	13 [0.512]	R13.5	5 [0.197]	4 [0.157]	—	—	—	M3
10 [0.394]	$\phi 3.3 [0.13]$ (through hole) counter bore $\phi 6.2 [0.244]$ (both sides) and M4 × 0.7 (both sides)	9.5 [0.374]	3.5 [0.138]	—	23 [0.906]	15 [0.591]	R15	5 [0.197]	4 [0.157]	—	—	—	M3
12 [0.472]	$\phi 4.3 [0.169]$ (through hole) counter bore $\phi 6.5 [0.256]$ (both sides) and M5 × 0.8 (both sides)	9.5 [0.374]	4.5 [0.177]	—	25 [0.984]	16.3 [0.642]	R16	6 [0.236]	5 [0.197]	—	—	1 [0.039]	M3
16 [0.630]	$\phi 4.3 [0.169]$ (through hole) counter bore $\phi 6.5 [0.256]$ (both sides) and M5 × 0.8 (both sides)	9.5 [0.374]	4.5 [0.177]	—	29 [1.142]	19.8 [0.780]	R19	8 [0.315]	6 [0.236]	—	—	1 [0.039]	M3
20 [0.787]	$\phi 4.3 [0.169]$ (through hole) counter bore $\phi 6.5 [0.256]$ (both sides) and M5 × 0.8 (both sides)	9.5 [0.374]	4.5 [0.177]	—	34 [1.339]	24 [0.945]	R22	10 [0.394]	8 [0.315]	—	—	1 [0.039]	M3
25 [0.984]	$\phi 5.1 [0.201]$ (through hole) counter bore $\phi 8 [0.315]$ (both sides) and M6 × 1 (both sides)	11.5 [0.453]	5.5 [0.217]	—	40 [1.575]	28 [1.102]	R25	12 [0.472]	10 [0.394]	—	—	1 [0.039]	M4
32 [1.260]	$\phi 5.1 [0.201]$ (through hole) counter bore $\phi 8 [0.315]$ (both sides) and M6 × 1 (both sides)	11.5 [0.453]	5.5 [0.217]	4.5 [0.177]	44 [1.732]	34 [1.339]	R29.5	16 [0.630]	14 [0.551]	15 [0.591]	13.6 [0.535]	1 [0.039]	M4
40 [1.575]	$\phi 6.9 [0.272]$ (through hole) counter bore $\phi 9.5 [0.374]$ (both sides) and M8 × 1.25 (both sides)	15.5 [0.610]	7.5 [0.295]	4.5 [0.177]	52 [2.047]	40 [1.575]	R35	16 [0.630]	14 [0.551]	15 [0.591]	13.6 [0.535]	1.6 [0.063]	M5

Dimensions of Male Thread Rod End Thread Specification (mm [in])

● $\phi 6$ [0.236] ~ $\phi 25$ [0.984]

● $\phi 32$ [1.260] · $\phi 40$ [1.575]

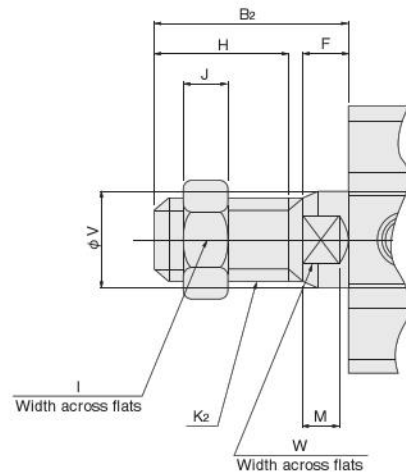
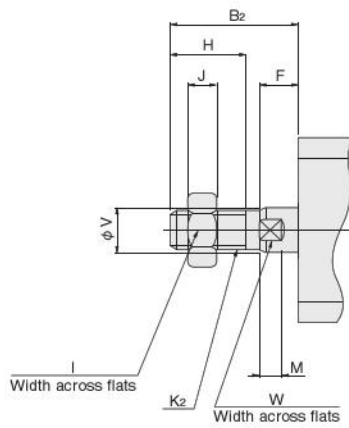

Bore	Code	B ₂	F	H	I	J	K ₂	M	V	W
6	[0.236]	15 [0.591]	5 [0.197]	8 [0.315]	5.5 [0.217]	1.8 [0.071]	M3 × 0.5	3 [0.118]	4 [0.157]	3.5 [0.138]
8	[0.315]	15 [0.591]	5 [0.197]	8 [0.315]	7 [0.276]	2.4 [0.094]	M4 × 0.7	3 [0.118]	5 [0.197]	4 [0.157]
10	[0.394]	15 [0.591]	5 [0.197]	8 [0.315]	7 [0.276]	2.4 [0.094]	M4 × 0.7	3 [0.118]	5 [0.197]	4 [0.157]
12	[0.472]	17 [0.669]	5 [0.197]	10 [0.394]	8 [0.315]	4 [0.157]	M5 × 0.8	3.5 [0.138]	6 [0.236]	5 [0.197]
16	[0.630]	20.5 [0.807]	5.5 [0.217]	13 [0.512]	10 [0.394]	5 [0.197]	M6 × 1	3.5 [0.138]	8 [0.315]	6 [0.236]
20	[0.787]	22.5 [0.886]	5.5 [0.217]	15 [0.591]	12 [0.472]	5 [0.197]	M8 × 1	4.5 [0.177]	10 [0.394]	8 [0.315]
25	[0.984]	24 [0.945]	6 [0.236]	15 [0.591]	14 [0.551]	6 [0.236]	M10 × 1.25	5 [0.197]	12 [0.472]	10 [0.394]
32	[1.260]	35 [1.378]	7 [0.276]	25 [0.984]	19 [0.748]	8 [0.315]	M14 × 1.5	6 [0.236]	16 [0.630]	14 [0.551]
40	[1.575]	35 [1.378]	7 [0.276]	25 [0.984]	19 [0.748]	8 [0.315]	M14 × 1.5	6 [0.236]	16 [0.630]	14 [0.551]

Remark: Cylinder joints and cylinder rod ends for mounting on a male thread rod end specification are also available. For details, see the general personal catalog.

Dimensions of Centering Location (mm [in])

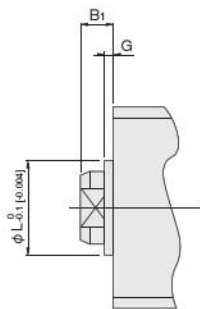

Bore	Code	B ₁	G	L
16	[0.630]	5.5 [0.217]	1.5 [0.059]	9.4 [0.370]
20	[0.787]	5.5 [0.217]	1.5 [0.059]	12 [0.472]
25	[0.984]	6 [0.236]	2 [0.079]	15 [0.591]
32	[1.260]	7 [0.276]	2 [0.079]	21 [0.827]
40	[1.575]	7 [0.276]	2 [0.079]	29 [1.142]

● Not available for $\phi 6$ [0.236], $\phi 8$ [0.315], $\phi 10$ [0.394], and $\phi 12$ [0.472]

JIG CYLINDERS C SERIES

CLEAN SPECIFICATION LOW FRICTION CYLINDERS

Double Acting Type

Symbol



Specifications

Item	Cylinder bore mm [in]	6 [0.236]	8 [0.315]	10 [0.394]	12 [0.472]	16 [0.630]	20 [0.787]	25 [0.984]	32 [1.260]	40 [1.575]
Operating type		Double acting type								
Media		Air								
Maximum operating pressure MPa [psi]		0.7 [102]								
Proof pressure MPa [psi]		1.05 [152]								
Operating temperature range °C [°F]		0 ~ 60 [32 ~ 140]								
Cushion		None			Rubber bumper type					
Lubrication		No								
Port size		M3×0.5			M5×0.8				Rc1/8	
Dust collection port		M3×0.5			M5×0.8					
Cleanliness		Class 4 equivalent (FED-STD Class 10 equivalent) (Vacuum suction from dust collection port. Based on Koganei standards. For details, refer to page 44.)								

Minimum Operation Pressure

Item	Cylinder bore mm [in]	6 [0.236]	8 [0.315]	10 [0.394]	12 [0.472]	16 [0.630]	20 [0.787]	25 [0.984]	32 [1.260]	40 [1.575]
Minimum operating pressure MPa [psi]		0.1 [15]	0.06 [9]	0.03 [4]		0.02 [3]			0.01 [1]	

Operating Speed Range

Item	Cylinder bore mm [in]	6 [0.236]	8 [0.315]	10 [0.394]	12 [0.472]	16 [0.630]	20 [0.787]	25 [0.984]	32 [1.260]	40 [1.575]
Operating speed range mm/s [in/sec]		1 ^{Note} ~ 500 [0.039 ~ 19.7]								

Note: When using $\phi 6$ [0.236] at 1 mm/s [0.039 in/sec], apply air pressure of at least 0.3 MPa [44 psi].

When using $\phi 8$ [0.315] to $\phi 40$ [1.575] at 1 mm/s [0.039 in/sec], apply air pressure of at least 0.15 MPa [22 psi].

When using reed switch type sensor switches, operates at cylinder speed of 30 mm/s [1.181 in/sec] or higher.

Bore Size and Stroke

For information about mid-stroke, refer to page 34.

Operating type	Bore	Standard stroke	
		Standard cylinders	Cylinder with magnet
Double acting type	6 [0.236]	5 [0.197], 10 [0.394], 15 [0.591], 20 [0.787]	5 [0.197], 10 [0.394], 15 [0.591], 20 [0.787]
	8 [0.315]		
	10 [0.394]		
	12 [0.472]	5 [0.197], 10 [0.394], 15 [0.591], 20 [0.787], 25 [0.984],	5 [0.197], 10 [0.394], 15 [0.591], 20 [0.787], 25 [0.984],
	16 [0.630]	30 [1.181]	30 [1.181]
	20 [0.787]	5 [0.197], 10 [0.394], 15 [0.591], 20 [0.787], 25 [0.984],	5 [0.197], 10 [0.394], 15 [0.591], 20 [0.787], 25 [0.984],
	25 [0.984]	30 [1.181], 35 [1.378], 40 [1.575], 45 [1.772], 50 [1.969]	30 [1.181], 35 [1.378], 40 [1.575], 45 [1.772], 50 [1.969]
	32 [1.260]	5 [0.197], 10 [0.394], 15 [0.591], 20 [0.787], 25 [0.984], 30 [1.181],	5 [0.197], 10 [0.394], 15 [0.591], 20 [0.787], 25 [0.984], 30 [1.181],
40 [1.575]	35 [1.378], 40 [1.575], 45 [1.772], 50 [1.969], 75 [2.953], 100 [3.9]	35 [1.378], 40 [1.575], 45 [1.772], 50 [1.969], 75 [2.953], 100 [3.9]	

Reference 1: Stroke tolerance $^{+1}_{0}$ [0.039]

2: $\phi 6$ [0.236], $\phi 8$ [0.315], and $\phi 10$ [0.394] cylinder bore mid-strokes are special handling (collar stoppers).

3: $\phi 12$ [0.472] to $\phi 40$ [1.575] cylinder bore mid-strokes basically are tube cut.

However, strokes up to 5 mm [0.197 in] with cylinder bores of $\phi 12$ [0.472] to $\phi 40$ [1.575] are not tube cut.

In this case, a collar stopper is used.

Order Codes for Clean Specification Low Friction Cylinders

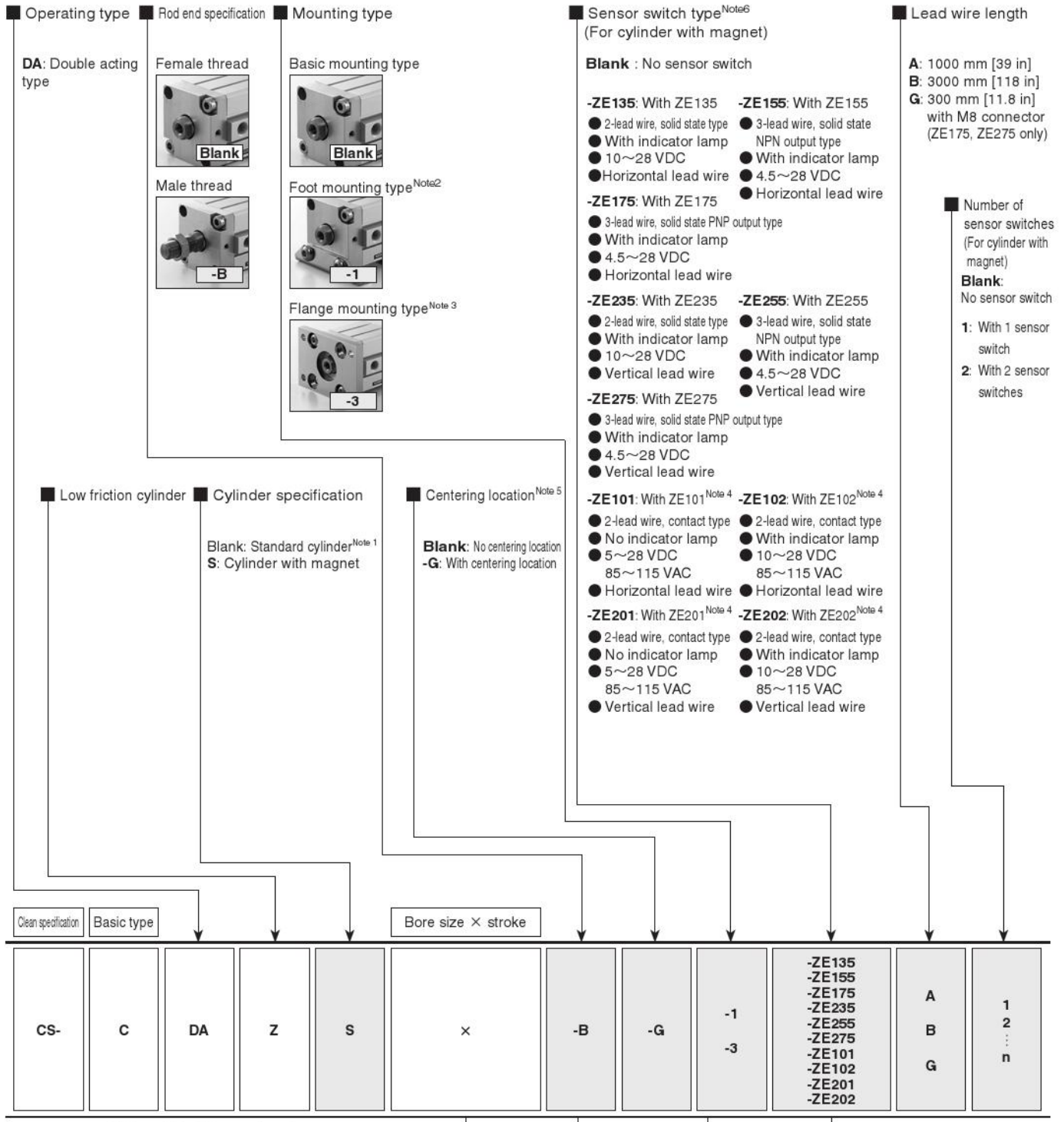

● See table of bore and stroke.

● For details about cylinder joints for male thread and cylinder rod ends, refer to the general personal catalog.

● For the order number of a sensor switch only, see page 49.

- Note 1: Clean specification low friction standard cylinders do not have a sensor switch magnet built in.
 2: Cannot be mounted on a cylinder with spigot joint (-G). Not available for cylinder bores $\phi 6$ [0.236], $\phi 8$ [0.315], or $\phi 10$ [0.394].
 3: Cannot be mounted on the rod side a cylinder with spigot joint (-G). Not available for cylinder bores $\phi 6$ [0.236], $\phi 8$ [0.315], or $\phi 10$ [0.394].
 4: Not available for cylinder bores $\phi 6$ [0.236], $\phi 8$ [0.315], or $\phi 10$ [0.394].
 5: Not available for cylinder bores $\phi 6$ [0.236] to $\phi 12$ [0.472].
 6: For details about sensor switches, see the general personal catalog.

- Mounting brackets are attached when shipped.
- When the stroke of a $\phi 12$ [0.472] or $\phi 16$ [0.630] foot bracket is less than 10 mm [0.394 in], it may be impossible to mount two sensor switches due to interference between the foot bracket and sensor switch. For details, contact your nearest Koganei sales office.

Additional Parts (To be ordered separately)

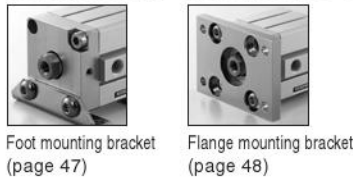

Inner Construction and Major Parts

● Double acting type (CS-CDAZ)

● $\phi 6$ [0.236] ~ $\phi 10$ [0.394]

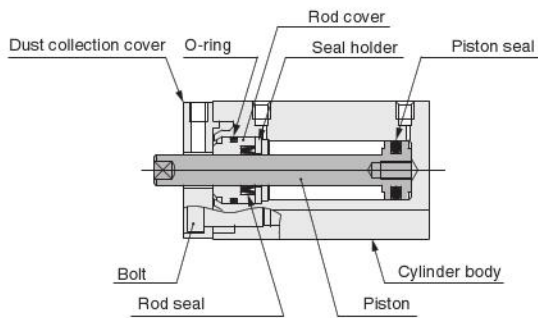

● $\phi 12$ [0.472] ~ $\phi 40$ [1.575]

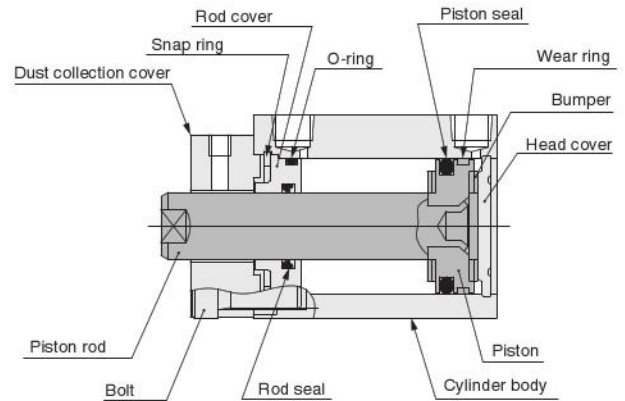

● Cylinder with magnet

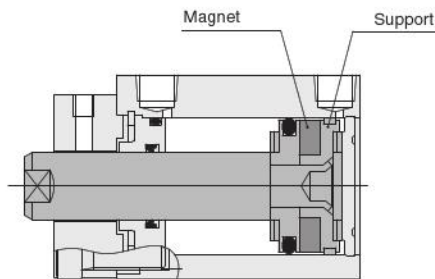

Major Parts and Materials

Article	Cylinder bore mm [in]	6 [0.236]	8 [0.315]	10 [0.394]	12 [0.472]	16 [0.630]	20 [0.787]	25 [0.984]	32 [1.260]	40 [1.575]	
Cylinder body		Aluminum alloy (anodized)									
Piston		Stainless steel		Aluminum alloy (special anti-rust treated)							
Piston rod		—		Stainless steel (with chrome plating)				Hard steel (with chrome plating)			
Gasket		Synthetic rubber (NBR)									
Rod cover		Aluminum alloy (special anti-abrasion treated)									
Bumper		—		Synthetic rubber (NBR)							
Magnet		Neodymium magnet				Plastic magnet					
Support		Copper alloy				Aluminum alloy (special anti-rust treated)					
Snap ring		—		Steel (nickel plated)							
Wear ring		—		Synthetic resin							
Dust collection cover		Aluminum alloy (anodized)									
Bolt		Stainless steel				Steel (nickel plated)				Stainless steel	

Seal Repair Kit

Bore mm [in]	Model	Set contents
12 [0.472]	SRK-CDAZ12	Piston seal: 1 Rod seal: 1 O-ring: 1
16 [0.630]	SRK-CDAZ16	
20 [0.787]	SRK-CDAZ20	
25 [0.984]	SRK-CDAZ25	
32 [1.260]	SRK-CDAZ32	
40 [1.575]	SRK-CDAZ40	

Note 1: There is no seal repair kit available for cylinder bores $\phi 6$ [0.236], $\phi 8$ [0.315], or $\phi 10$ [0.394].

2: Use special grease. For information about grease, contact Koganei.

Mass

Bore size mm [in]	Zero stroke Mass	Additional mass for each 1 mm stroke	Additional mass of cylinder with magnet	Mass of mounting brackets		Additional mass of sensor switch ^{Note}	
				Foot bracket	Flange bracket	ZE □□□ A	ZE □□□ B
						ZE □□□ G	
6 [0.236]	17.2 [0.607]	0.74 [0.026]	3.9 [0.138]	—	—	15 [0.529]	35 [1.235]
8 [0.315]	22.7 [0.801]	0.95 [0.034]	5.4 [0.190]	—	—		
10 [0.394]	29.3 [1.034]	1.12 [0.040]	6.8 [0.240]	—	—		
12 [0.472]	49.3 [1.739]	1.28 [0.045]	8 [0.282]	50 [1.764]	55 [1.940]		
16 [0.630]	67.9 [2.395]	1.62 [0.057]	11 [0.388]	62 [2.187]	71 [2.504]		
20 [0.787]	100.2 [3.5]	2.26 [0.080]	27 [0.952]	84 [2.963]	101 [3.6]		
25 [0.984]	146.1 [5.2]	3.11 [0.110]	39 [1.376]	104 [3.7]	160 [5.6]		
32 [1.260]	235.7 [8.3]	4.11 [0.145]	28 [0.988]	126 [4.4]	186 [6.6]		
40 [1.575]	347.0 [12.2]	4.47 [0.158]	37 [1.305]	160 [5.6]	335 [11.8]		

Note: Sensor switch types A, B, and G are lead wire lengths. A: 1000 mm [39 in], B: 3000 mm [118 in], G: 300 mm [11.8 in], with M8 connector

Cleanliness Evaluation (Clean Specification Low Friction Cylinders)

Cleanliness evaluation methods for current clean specification pneumatic equipment are not defined by JIS or other standards. Because of this, Koganei devises its own independent measurement methods for cleanliness and carries out evaluation accordingly.

Jig cylinder C series clean specification low friction cylinder dust volume is measured using the method described below.

1. Samples being measured

CS-CDAZ40 × 100 (Load: 288 g [10.2 oz])

2. Measurement conditions

2-1 Test circuit: With suction from dust collection port

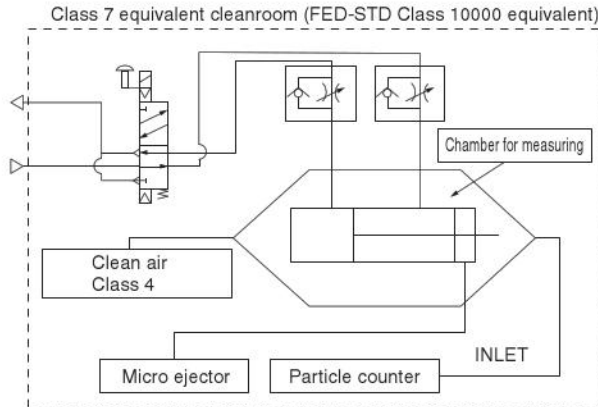

2-2 Sample operation conditions

- Operating frequency: 0.5 Hz
- Average operating speed: 300 mm/s [11.8 in/sec]
- Applied pressure: 0.5 MPa [73 psi]
- Suction conditions: Micro ejector: ME05; Primary: 0.5 MPa [73 psi] application; Tubing used: $\phi 6$ [0.236]
- Mounting direction: Horizontal
- Chamber volume used: 8.3 ℓ

3. Particle counter used

- Manufacturer/Model: RION Co., Ltd./KM20
- Suction flow: 28.3 ℓ /min (ANR) [1.000 ft³/min (SCFM)]
- Passable particle sizes: 0.1 μm , 0.2 μm , 0.3 μm , 0.5 μm , 0.7 μm , 1.0 μm

4. Measurement methodology

- 4-1 Measurement system dust emission volume check
Measurement for nine minutes with the particle counter without operation of the test sample in accordance with conditions 1 and 2 to confirm a count value no greater than 1.
- 4-2 Actual measurement
Operation of the test sample in accordance with conditions 1 and 2 for 36 minutes, total value measurement for the latter 18 minutes.
- 4-3 Re-confirmation
Performance of check 4-1 again to re-check measurement system dust emission.
- 4-4 Measurement value conversion
Conversion of the total value obtained during the latter 18 minutes of 4-2 to a value per 10 operations of the cylinder.

5. Measurement result precautions^{Note}

- Suction from dust collection port

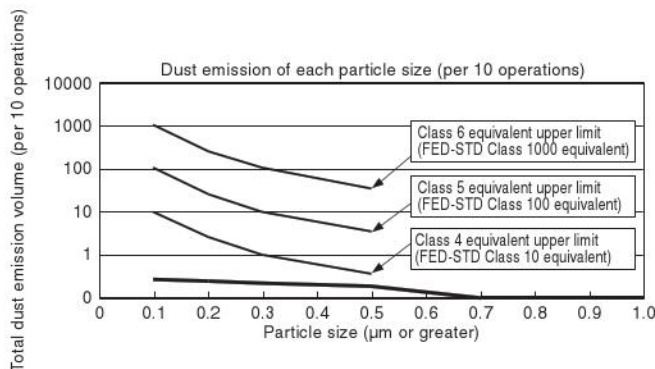

Note: The individual particle size graphs are for measurements following one million product operations.

Dimensions of Clean Specification Double Acting Low Friction Cylinders (mm [in])

● $\phi 6$ [0.236] ~ $\phi 25$ [0.984]

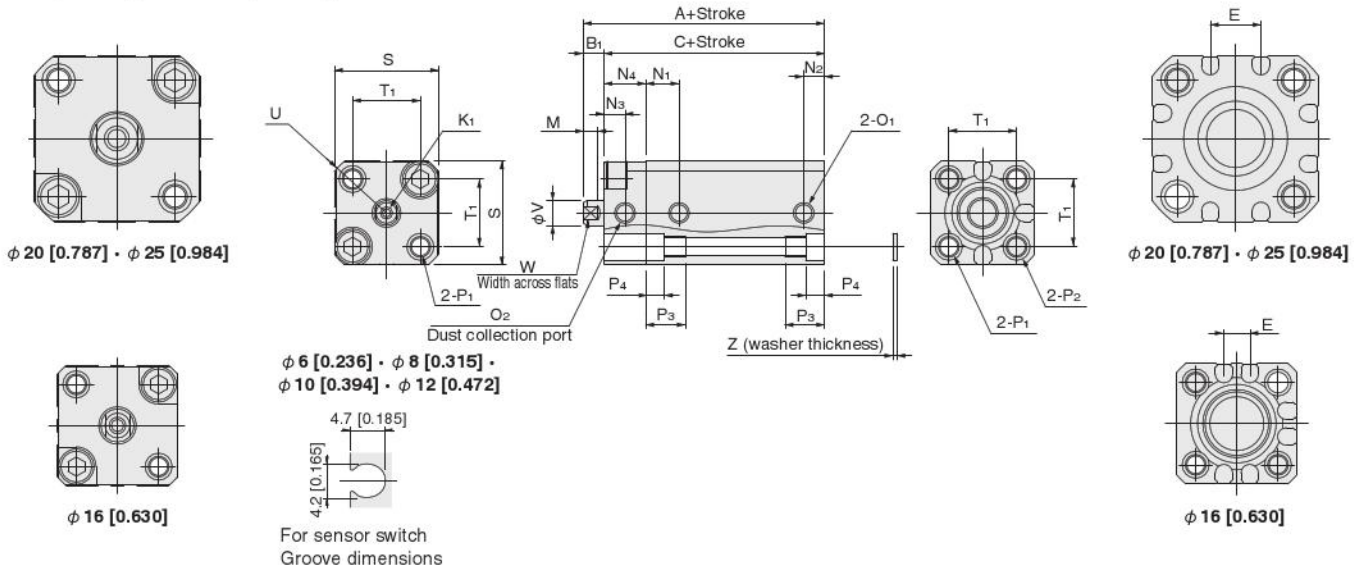

● $\phi 32$ [1.260] · $\phi 40$ [1.575]

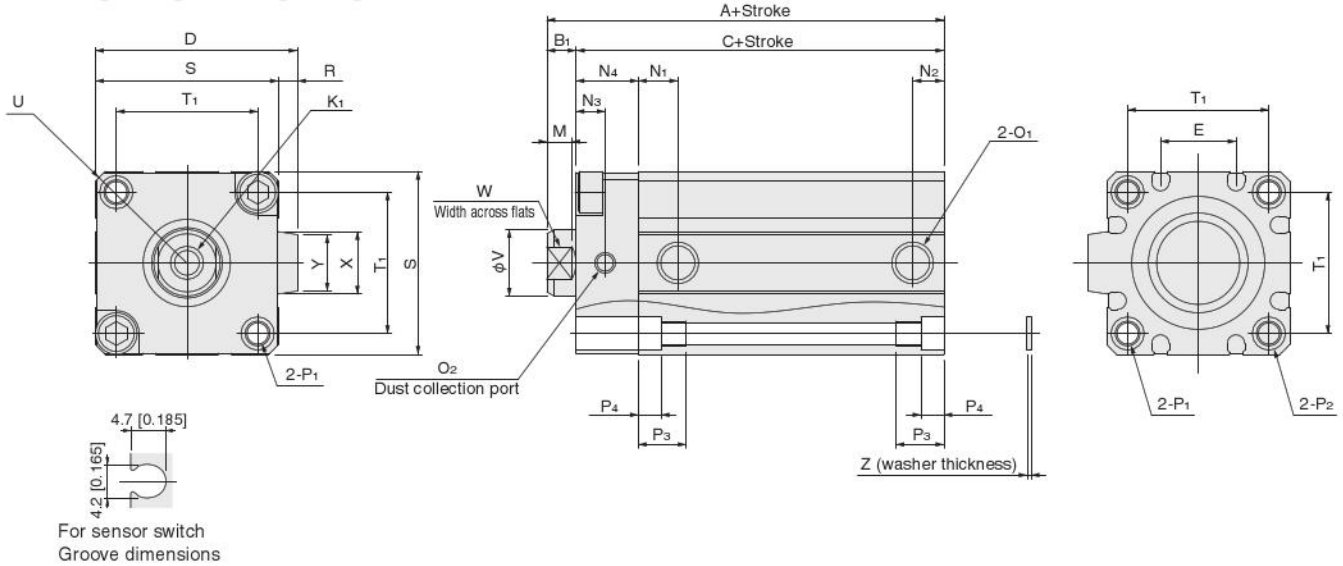

Model Bore Code	Standard cylinder (CS-CDAZ)			Cylinder with magnet (CS-CDAZS)			D	E	K ₁	M	N ₁	N ₂	N ₃	N ₄	O ₁	O ₂
	A	B ₁	C	A	B ₁	C										
6 [0.236]	24 [0.945]	5 [0.197]	19 [0.748]	29 [1.142]	5 [0.197]	24 [0.945]	—	—	M2.5×0.45, depth 5 [0.197]	3 [0.118]	6.5 [0.256]	3.5 [0.138]	2.5 [0.098]	5 [0.197]	M3×0.5	M3×0.5
8 [0.315]	25 [0.984]	5 [0.197]	20 [0.787]	30 [1.181]	5 [0.197]	25 [0.984]	—	—	M3×0.5, depth 5 [0.197]	3 [0.118]	7.5 [0.295]	3.5 [0.138]	2.5 [0.098]	5 [0.197]	M3×0.5	M3×0.5
10 [0.394]	26 [1.024]	5 [0.197]	21 [0.827]	31 [1.220]	5 [0.197]	26 [1.024]	—	—	M3×0.5, depth 5 [0.197]	3 [0.118]	8 [0.315]	4 [0.157]	2.5 [0.098]	5 [0.197]	M3×0.5	M3×0.5
12 [0.472]	37 [1.457]	5 [0.197]	32 [1.260]	42 [1.654]	5 [0.197]	37 [1.457]	—	—	M3×0.5, depth 6 [0.236]	3.5 [0.138]	8 [0.315]	5 [0.197]	5 [0.197]	10 [0.394]	M5×0.8	M5×0.8
16 [0.630]	37.5 [1.476]	5.5 [0.217]	32 [1.260]	42.5 [1.673]	5.5 [0.217]	37 [1.457]	—	6.2 [0.244]	M4×0.7, depth 8 [0.315]	3.5 [0.138]	8 [0.315]	5 [0.197]	5 [0.197]	10 [0.394]	M5×0.8	M5×0.8
20 [0.787]	40 [1.575]	5.5 [0.217]	34.5 [1.358]	50 [1.969]	5.5 [0.217]	44.5 [1.752]	—	12.2 [0.480]	M5×0.8, depth 10 [0.394]	4.5 [0.177]	9.5 [0.374]	5 [0.197]	5 [0.197]	10 [0.394]	M5×0.8	M5×0.8
25 [0.984]	42 [1.654]	6 [0.236]	36 [1.417]	52 [2.047]	6 [0.236]	46 [1.811]	—	12.2 [0.480]	M6×1, depth 10 [0.394]	5 [0.197]	10.5 [0.413]	5 [0.197]	5 [0.197]	10 [0.394]	M5×0.8	M5×0.8
32 [1.260]	50 [1.969]	7 [0.276]	43 [1.693]	55 [2.165]	7 [0.276]	48 [1.890]	48.5 [1.909]	18.2 [0.717]	M8×1.25, depth 12 [0.472]	6 [0.236]	9.5 [0.374]	7.5 [0.295]	7 [0.276]	15 [0.591]	Rc1/8	M5×0.8
40 [1.575]	53 [2.087]	7 [0.276]	46 [1.811]	58 [2.283]	7 [0.276]	51 [2.008]	56.5 [2.224]	18.2 [0.717]	M8×1.25, depth 12 [0.472]	6 [0.236]	10.5 [0.413]	7.5 [0.295]	7 [0.276]	15 [0.591]	Rc1/8	M5×0.8

Bore Code	P ₁	P ₂	P ₃	P ₄	R	S	T ₁	U	V	W	X	Y	Z	Applicable through bot
6 [0.236]	$\phi 3.3$ [0.13] (through hole) counter bore $\phi 6$ [0.236] (both sides) and M4×0.7 (both sides)	Counter bore $\phi 6$ [0.236] and M4×0.7	9.5 [0.374]	3.5 [0.138]	—	19 [0.748]	11 [0.433]	R12	4 [0.157]	3.5 [0.138]	—	—	—	M3
8 [0.315]	$\phi 3.3$ [0.13] (through hole) counter bore $\phi 6.2$ [0.244] (both sides) and M4×0.7 (both sides)	Counter bore $\phi 6.2$ [0.244] and M4×0.7	9.5 [0.374]	3.5 [0.138]	—	21 [0.827]	13 [0.512]	R13.5	5 [0.197]	4 [0.157]	—	—	—	M3
10 [0.394]	$\phi 3.3$ [0.13] (through hole) counter bore $\phi 6.2$ [0.244] (both sides) and M4×0.7 (both sides)	Counter bore $\phi 6.2$ [0.244] and M4×0.7	9.5 [0.374]	3.5 [0.138]	—	23 [0.906]	15 [0.591]	R15	5 [0.197]	4 [0.157]	—	—	—	M3
12 [0.472]	$\phi 4.3$ [0.169] (through hole) counter bore $\phi 6.5$ [0.256] (both sides) and M5×0.8 (both sides)	Counter bore $\phi 6.5$ [0.256] and M5×0.8	9.5 [0.374]	4.5 [0.177]	—	25 [0.984]	16.3 [0.642]	R16	6 [0.236]	5 [0.197]	—	—	1 [0.039]	M3
16 [0.630]	$\phi 4.3$ [0.169] (through hole) counter bore $\phi 6.5$ [0.256] (both sides) and M5×0.8 (both sides)	Counter bore $\phi 6.5$ [0.256] and M5×0.8	9.5 [0.374]	4.5 [0.177]	—	29 [1.142]	19.8 [0.780]	R19	8 [0.315]	6 [0.236]	—	—	1 [0.039]	M3
20 [0.787]	$\phi 4.3$ [0.169] (through hole) counter bore $\phi 6.5$ [0.256] (both sides) and M5×0.8 (both sides)	Counter bore $\phi 6.5$ [0.256] and M5×0.8	9.5 [0.374]	4.5 [0.177]	—	34 [1.339]	24 [0.945]	R22	10 [0.394]	8 [0.315]	—	—	1 [0.039]	M3
25 [0.984]	$\phi 5.1$ [0.201] (through hole) counter bore $\phi 8$ [0.315] (both sides) and M6×1 (both sides)	Counter bore $\phi 8$ [0.315] and M6×1	11.5 [0.453]	5.5 [0.217]	—	40 [1.575]	28 [1.102]	R25	12 [0.472]	10 [0.394]	—	—	1 [0.039]	M4
32 [1.260]	$\phi 5.1$ [0.201] (through hole) counter bore $\phi 8$ [0.315] (both sides) and M6×1 (both sides)	Counter bore $\phi 8$ [0.315] and M6×1	11.5 [0.453]	5.5 [0.217]	4.5 [0.177]	44 [1.732]	34 [1.339]	R29.5	16 [0.630]	14 [0.551]	15 [0.591]	13.6 [0.535]	1 [0.039]	M4
40 [1.575]	$\phi 6.9$ [0.272] (through hole) counter bore $\phi 9.5$ [0.374] (both sides) and M8×1.25 (both sides)	Counter bore $\phi 9.5$ [0.374] and M8×1.25	15.5 [0.610]	7.5 [0.295]	4.5 [0.177]	52 [2.047]	40 [1.575]	R35	16 [0.630]	14 [0.551]	15 [0.591]	13.6 [0.535]	1.6 [0.063]	M5

Dimensions of Male Thread Rod End Thread Specification (mm [in])

● $\phi 6$ [0.236] ~ $\phi 25$ [0.984]

● $\phi 32$ [1.260] · $\phi 40$ [1.575]

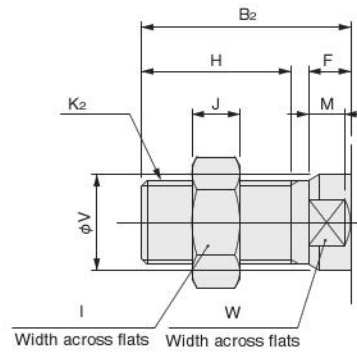
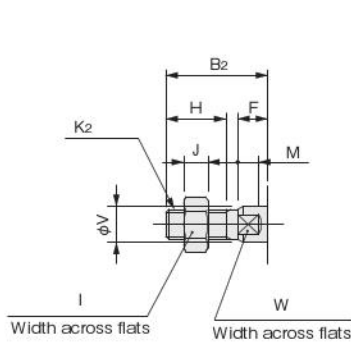

Bore	Code	B ₂	F	H	I	J	K ₂	M	V	W
6	[0.236]	15 [0.591]	5 [0.197]	8 [0.315]	5.5 [0.217]	1.8 [0.071]	M3×0.5	3 [0.118]	4 [0.157]	3.5 [0.138]
8	[0.315]	15 [0.591]	5 [0.197]	8 [0.315]	7 [0.276]	2.4 [0.094]	M4×0.7	3 [0.118]	5 [0.197]	4 [0.157]
10	[0.394]	15 [0.591]	5 [0.197]	8 [0.315]	7 [0.276]	2.4 [0.094]	M4×0.7	3 [0.118]	5 [0.197]	4 [0.157]
12	[0.472]	17 [0.669]	5 [0.197]	10 [0.394]	8 [0.315]	4 [0.157]	M5×0.8	3.5 [0.138]	6 [0.236]	5 [0.197]
16	[0.630]	20.5 [0.807]	5.5 [0.217]	13 [0.512]	10 [0.394]	5 [0.197]	M6×1	3.5 [0.138]	8 [0.315]	6 [0.236]
20	[0.787]	22.5 [0.886]	5.5 [0.217]	15 [0.591]	12 [0.472]	5 [0.197]	M8×1	4.5 [0.177]	10 [0.394]	8 [0.315]
25	[0.984]	24 [0.945]	6 [0.236]	15 [0.591]	14 [0.551]	6 [0.236]	M10×1.25	5 [0.197]	12 [0.472]	10 [0.394]
32	[1.260]	35 [1.378]	7 [0.276]	25 [0.984]	19 [0.748]	8 [0.315]	M14×1.5	6 [0.236]	16 [0.630]	14 [0.551]
40	[1.575]	35 [1.378]	7 [0.276]	25 [0.984]	19 [0.748]	8 [0.315]	M14×1.5	6 [0.236]	16 [0.630]	14 [0.551]

Remark: Cylinder joints and cylinder rod ends for mounting on a male thread rod end specification are also available. For details, see the general personal catalog.

Dimensions of Centering Location (mm [in])

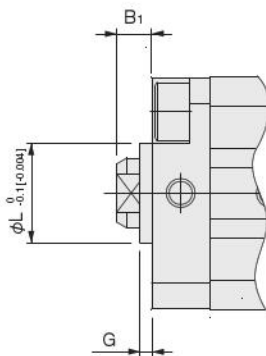

Bore	Code	B ₁	G	L
16	[0.630]	5.5 [0.217]	1.5 [0.059]	12 [0.472]
20	[0.787]	5.5 [0.217]	1.5 [0.059]	15 [0.591]
25	[0.984]	6 [0.236]	2 [0.079]	17 [0.669]
32	[1.260]	7 [0.276]	2 [0.079]	21 [0.827]
40	[1.575]	7 [0.276]	2 [0.079]	29 [1.142]

● Not available for $\phi 6$ [0.236], $\phi 8$ [0.315], $\phi 10$ [0.394], and $\phi 12$ [0.472]

JIG CYLINDERS C SERIES MOUNTING BRACKETS

Foot Mounting Bracket, Flange Mounting Bracket, Clevis Mounting Bracket

Order Codes of Mounting Bracket Only

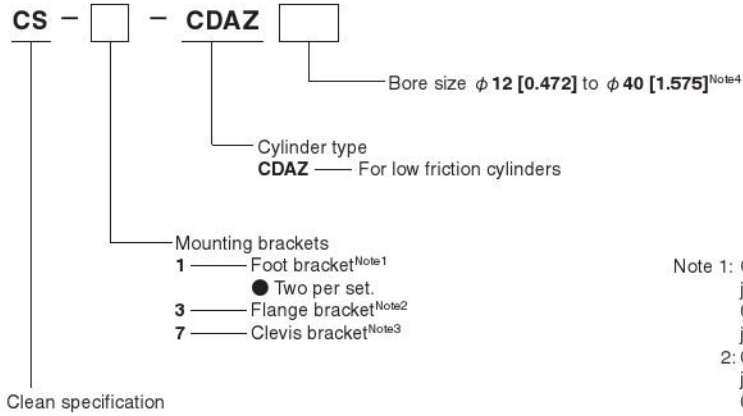

- Note 1: Cannot be mounted on a low friction cylinder with a cylinder with spigot joint, which has a ϕ 40 [1.575] cylinder bore (-G). Cannot be mounted on a clean specification low friction cylinder with spigot joint, of any cylinder bore (-G).
- Note 2: Cannot be mounted on the rod side of a low friction cylinder with spigot joint, which has a ϕ 40 [1.575] cylinder bore (-G). Cannot be mounted on the rod side of a clean specification low friction cylinder with spigot joint, of any cylinder bore.
- Note 3: Cannot be mounted on a clean specification low friction cylinder.
- Note 4: Not available for cylinder bores ϕ 6 [0.236], ϕ 8 [0.315], or ϕ 10 [0.394].

Dimensions of Foot Mounting Bracket (mm [in])

● ϕ 12 [0.472] · ϕ 16 [0.630]

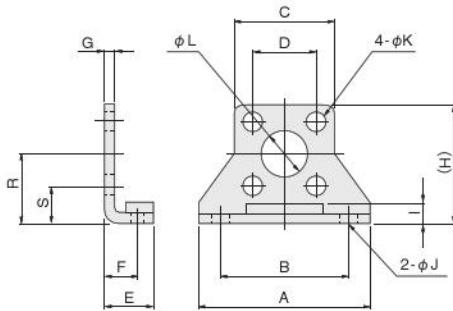

● ϕ 20 [0.787] ~ ϕ 40 [1.575]

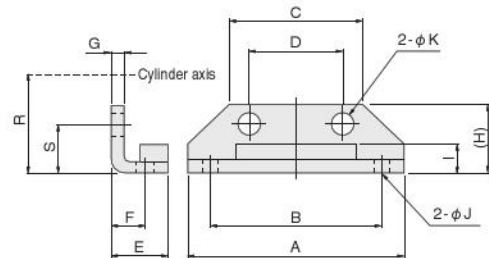

● Mounting screw (4 attached)

● For ϕ 12 [0.472] ~ ϕ 40 [1.575]

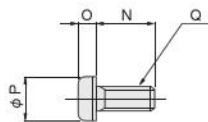

Material: Steel																					
Bore	Code	A	B	C	D	E	F	G	H	I	J	K	L	N [lbf]	O	P	Q	R	S	Weight	g
12	[0.472]	44 [1.732]	34 [1.339]	25 [0.984]	16.3 [0.642]	12.5 [0.492]	8 [0.315]	2 [0.079]	29.5 [1.161]	4.5 [0.177]	4.5 [0.177]	5.5 [0.217]	11 [0.433]	12 [12.22] [0.472 0.486]	2.7 [0.106]	9.5 [0.374]	M5	17 [0.669]	8.9 [0.350]	50 [54] [1.764 1.905]	
16	[0.630]	48 [1.890]	38 [1.496]	29 [1.142]	19.8 [0.780]	13 [0.512]	8 [0.315]	2 [0.079]	33.5 [1.319]	4.5 [0.177]	4.5 [0.177]	5.5 [0.217]	11 [0.433]	12 [12.22] [0.472 0.486]	2.7 [0.106]	9.5 [0.374]	M5	19 [0.748]	9.1 [0.358]	62 [66] [2.187 2.328]	
20	[0.787]	54 [2.126]	44 [1.732]	34 [1.339]	24 [0.945]	15 [0.591]	9.2 [0.362]	3.2 [0.126]	16.5 [0.650]	7 [0.276]	4.5 [0.177]	5.5 [0.217]	-	12 [12.22] [0.472 0.486]	2.7 [0.106]	9.5 [0.374]	M5	24 [0.945]	12 [0.472]	84 [88] [2.963 3.104]	
25	[0.984]	64 [2.520]	52 [2.047]	40 [1.575]	28 [1.102]	16.5 [0.650]	10.7 [0.421]	3.2 [0.126]	17.5 [0.689]	6 [0.236]	5.5 [0.217]	6.6 [0.260]	-	14 [14.30] [0.551 0.564]	3.3 [0.130]	10.5 [0.413]	M6	26 [1.024]	12 [0.472]	104 [109] [3.7 3.8]	
32	[1.260]	68 [2.677]	56 [2.205]	44 [1.732]	34 [1.339]	17 [0.669]	11.2 [0.441]	3.2 [0.126]	19 [0.748]	8 [0.315]	5.5 [0.217]	6.6 [0.260]	-	14 [14.30] [0.551 0.564]	3.3 [0.130]	10.5 [0.413]	M6	30 [1.181]	13 [0.512]	126 [134] [4.4 4.7]	
40	[1.575]	78 [3.071]	64 [2.520]	52 [2.047]	40 [1.575]	18.2 [0.717]	11.2 [0.441]	3.2 [0.126]	19 [0.748]	7 [0.276]	6.6 [0.260]	9 [0.354]	-	20 [20.15] [0.787 0.791]	4.4 [0.173]	14 [0.551]	M8	33 [1.299]	13 [0.512]	160 [172] [5.6 6.1]	

Remarks: Values in parentheses are clean specification.

When there are two values in parentheses, the left value is for the head side while the right value is for the rod side.

Note: When mounting for clean specification, remove the dust collection cover fixing bolt (1), and secure with the mounting screw that comes with the bracket.

Dimensions of Flange Mounting Bracket (mm [in])

● $\phi 12$ [0.472] · $\phi 16$ [0.630]

● Mounting screw^{Note}
For $\phi 12$ [0.472] ~
 $\phi 40$ [1.575]

● $\phi 20$ [0.787] ~ $\phi 40$ [1.575]

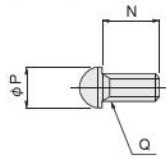
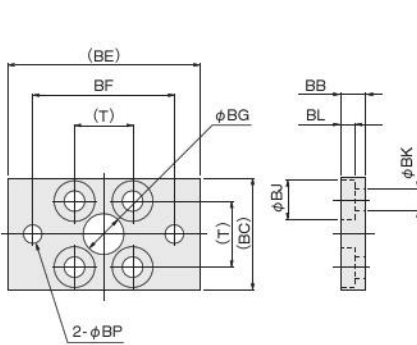

Note: Low friction cylinders are those below.
 $\phi 12$ [0.472], $\phi 16$ [0.630]: Two screws attached
 $\phi 20$ [0.787] to $\phi 40$ [1.575]: Four screws attached
For clean specification low friction cylinders, two screws for the rod side (all sizes) are attached, and two screws for the head side.

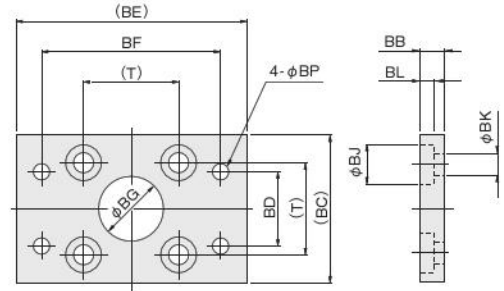

Bore	Code	N	P	Q	T	BB	BC	BD	BE	BF	BG	BJ	BK	BL	BP	Weight g
12	[0.472]	12 [12.22] [0.472, 0.866]	9.5 [0.374]	M5	16.3 [0.642]	6 [0.236]	28 [1.102]	—	50 [1.969]	38 [1.496]	11 [0.433]	10 [0.394]	5.5 [0.217]	3.6 [0.142]	4.5 [0.177]	55 (60) [1.840 (2.116)]
16	[0.630]	12 [12.22] [0.472, 0.866]	9.5 [0.374]	M5	19.8 [0.780]	6 [0.236]	32 [1.260]	—	54 [2.126]	42 [1.654]	11 [0.433]	10 [0.394]	5.5 [0.217]	3.6 [0.142]	4.5 [0.177]	71 (76) [2.504 (2.681)]
20	[0.787]	12 [12.22] [0.472, 0.866]	9.5 [0.374]	M5	24 [0.945]	6 [0.236]	36 [1.417]	24 [0.945]	58 [2.283]	46 [1.811]	15 [0.591]	10 [0.394]	5.5 [0.217]	3.6 [0.142]	4.5 [0.177]	101 (106) [3.6 (3.7)]
25	[0.984]	14 [14.25] [0.551, 0.984]	10.5 [0.413]	M6	28 [1.102]	8 [0.315]	42 [1.654]	28 [1.102]	68 [2.677]	54 [2.126]	17 [0.669]	11 [0.433]	6.6 [0.260]	4.3 [0.169]	5.5 [0.217]	160 (170) [5.6 (6.0)]
32	[1.260]	14 [14.30] [0.551, 1.181]	10.5 [0.413]	M6	34 [1.339]	8 [0.315]	48 [1.890]	34 [1.339]	72 [2.835]	58 [2.283]	22 [0.866]	11 [0.433]	6.6 [0.260]	4.3 [0.169]	5.5 [0.217]	186 (200) [6.6 (7.1)]
40	[1.575]	20 [20.35] [0.787, 1.378]	14 [0.551]	M8	40 [1.575]	8 [0.315]	58 [2.283]	40 [1.575]	84 [3.307]	68 [2.677]	28 [1.102]	15 [0.591]	9 [0.354]	5.3 [0.209]	6.6 [0.260]	335 (359) [11.8 (12.7)]

Material: Steel

Remarks: Values in parentheses are clean specification.

When there are two values in parentheses, the left value is for the head side while the right value is for the rod side.

Dimensions of Clevis Mounting Bracket (mm [in])

● $\phi 12$ [0.472] ~ $\phi 40$ [1.575]

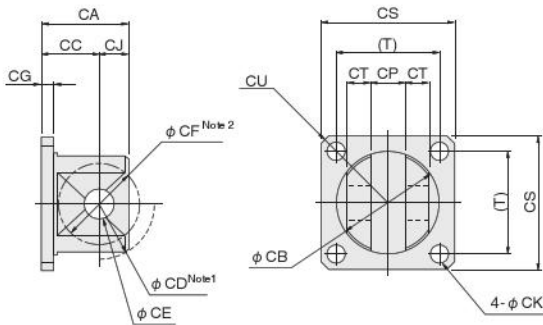

● Mounting screw (2 attached)
For $\phi 12$ [0.472] ~
 $\phi 40$ [1.575]

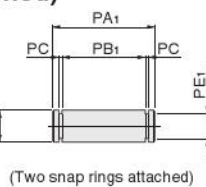
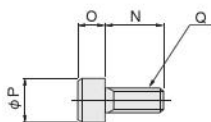

(Two snap rings attached)

Bore	Code	N	O	P	Q	T	CA	CB	CC	CD	CE	CF	CG	CJ	CK	CP	CS	CT	CU	PA ₁	PB ₁	PC	PD	PE ₁	Weight g
12	[0.472]	12 [0.472]	5 [0.197]	8.5 [0.335]	M5	16.3 [0.642]	15 [0.591]	12 [0.472]	11 [0.433]	R7.5	4 [0.157]	R 5	4 [0.157]	4 [0.157]	5.5 [0.217]	4 [0.157]	25 [0.984]	3 [0.118]	R16	15 [0.591]	10.6 [0.417]	0.7 [0.028]	4 [0.157]	2.5 [0.098]	30 [1.058]
16	[0.630]	12 [0.472]	5 [0.197]	8.5 [0.335]	M5	19.8 [0.780]	17 [0.669]	16 [0.630]	12 [0.472]	R10	5 [0.197]	R 6	4 [0.157]	5 [0.197]	5.5 [0.217]	5 [0.197]	29 [1.142]	3.5 [0.138]	R19	17 [0.669]	12.6 [0.498]	0.7 [0.028]	5 [0.197]	3 [0.118]	40 [1.411]
20	[0.787]	12 [0.472]	5 [0.197]	8.5 [0.335]	M5	24 [0.945]	25 [0.984]	22 [0.866]	17 [0.669]	R14	8 [0.315]	R11	4 [0.157]	8 [0.315]	5.5 [0.217]	8 [0.315]	34 [1.339]	5.2 [0.205]	R25	24.4 [0.961]	18.6 [0.722]	0.9 [0.035]	8 [0.315]	6 [0.236]	75 [2.646]
25	[0.984]	16 [0.630]	6 [0.236]	10 [0.394]	M6	28 [1.102]	25 [0.984]	26 [1.024]	17 [0.669]	R16	8 [0.315]	R11	4 [0.157]	8 [0.315]	6 [0.236]	8 [0.315]	40 [1.575]	5.2 [0.205]	R25	24.4 [0.961]	18.6 [0.722]	0.9 [0.035]	8 [0.315]	6 [0.236]	100 [3.5]
32	[1.260]	16 [0.630]	6 [0.236]	10 [0.394]	M6	34 [1.339]	29 [1.142]	34 [1.339]	19 [0.748]	R20	10 [0.394]	R12.5	4 [0.157]	10 [0.394]	6 [0.236]	12 [0.472]	44 [1.732]	5.2 [0.205]	R29.5	34 [1.339]	29.2 [1.150]	0.9 [0.035]	10 [0.394]	8 [0.315]	165 [5.8]
40	[1.575]	20 [0.787]	8 [0.315]	13 [0.512]	M8	40 [1.575]	29 [1.142]	34 [1.339]	19 [0.748]	R20	10 [0.394]	R12.5	4 [0.157]	10 [0.394]	8 [0.315]	12 [0.472]	52 [2.047]	5.2 [0.205]	R35	34 [1.339]	29.2 [1.150]	0.9 [0.035]	10 [0.394]	8 [0.315]	200 [7.1]

Material: Steel

Note 1: CD = Swing range of the clevis itself.

2: CF = Maximum allowable swing radius of the opposing bracket.

Remark: Installation is by two bolts.

JIG CYLINDERS C SERIES SENSOR SWITCHES

Solid State Type, Reed Switch Type

Order Codes

  - CDAS

Lead wire length

A: 1000 mm [39 in]

B: 3000 mm [118 in]

G: 300 mm [11.8 in] with M8 connector (ZE175, ZE275 only)

Sensor switch model

ZE135: Solid state type	2 lead wires	With indicator	10 ~ 28 VDC	Horizontal lead wire	ZE101: Contact type	Without indicator	5 ~ 28 VDC	Horizontal lead wire
ZE155: Solid state type	3 lead wires NPN output type	With indicator	4.5 ~ 28 VDC	Horizontal lead wire			85 ~ 115 VAC	
ZE175: Solid state type	3 lead wires PNP output type	With indicator	4.5 ~ 28 VDC	Horizontal lead wire	ZE102: Contact type	With indicator	10 ~ 28 VDC	Horizontal lead wire
ZE235: Solid state type	2 lead wires	With indicator	10 ~ 28 VDC	Vertical lead wire			85 ~ 115 VAC	
ZE255: Solid state type	3 lead wires NPN output type	With indicator	4.5 ~ 28 VDC	Vertical lead wire	ZE201: Contact type	Without indicator	5 ~ 28 VDC	Vertical lead wire
ZE275: Solid state type	3 lead wires PNP output type	With indicator	4.5 ~ 28 VDC	Vertical lead wire			85 ~ 115 VAC	
					ZE202: Contact type	With indicator	10 ~ 28 VDC	Vertical lead wire
							85 ~ 115 VAC	

Minimum Allowable Cylinder Stroke for Sensor Switch Use

● Solid State Type

mm [in]

Cylinder bore	Two mounted ^{Note}		One mounted
	One surface mounting	Two surface mounting	
6-12 [0.236-0.472]	30 [1.181]	10 [0.394]	5 [0.197]
16-40 [0.63-1.575]	10 [0.394]		

Note: Two can be mounted with a 5 mm [0.197 in] stroke.
However, care should be taken because overlap may occur.

● Reed Switch Type

mm [in]

Cylinder bore	Two mounted		One mounted
	One surface mounting	Two surface mounting	
12 [0.472]	30 [1.181]	10 [0.394]	10 [0.394]
16-40 [0.63-1.575]	10 [0.394]		

Moving Sensor Switch

- Loosening the screw allows the sensor switch to be moved along the switch mounting groove of the cylinder tube.
- The tightening torque for the screws is 0.1 to 0.2 N·m [0.885 to 1.770 in·lbf].

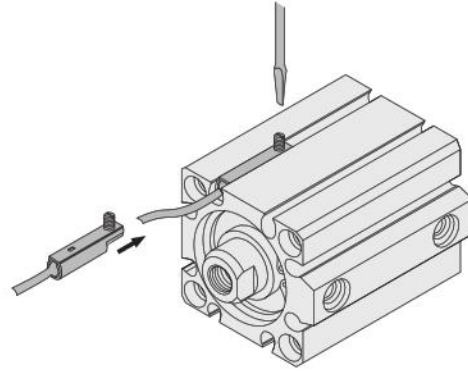

Sensor Switch Operating Range, Response Differential, and Maximum Sensing Location

● Operating range: ℓ

The range from where the piston turns the switch on and the point where the switch is turned off as the piston travels in the same direction.

● Response differential: C

The distance between the point where the piston turns the switch on and the point where the switch is turned off as the piston travels in the opposite direction.

● Solid State Type

mm [in]

Item \ Bore	6 [0.236]	8 [0.315]	10 [0.394]	12 [0.472]	16 [0.630]	20 [0.787]	25 [0.984]	32 [1.260]	40 [1.575]
Operating range: ℓ	1.8-3.0 [0.071-0.118]	1.8-3.0 [0.071-0.118]	2.0-3.2 [0.079-0.126]	2-4 [0.079-0.157]	2-5 [0.079-0.197]	3.5-7.5 [0.138-0.295]	4-8 [0.157-0.315]	3-7 [0.118-0.276]	3.5-7.5 [0.138-0.295]
Response differential: C	0.2 [0.008] or less			0.5 [0.020] or less					
Maximum sensing location	6 [0.236]								

Remark: The values in the table above are reference values.

● Reed Switch Type

mm [in]

Item \ Bore	12 [0.472]	16 [0.630]	20 [0.787]	25 [0.984]	32 [1.260]	40 [1.575]
Operating range: ℓ	4.5-8.5 [0.177-0.335]	5.5-9.5 [0.217-0.374]	9-13.5 [0.354-0.531]	10-15.5 [0.394-0.61]	8-12 [0.315-0.472]	8.5-14 [0.335-0.551]
Response differential: C	1.0 [0.039] or less		2.0 [0.079] or less			
Maximum sensing location	10 [0.394]					

Remark: The values in the table above are reference values.

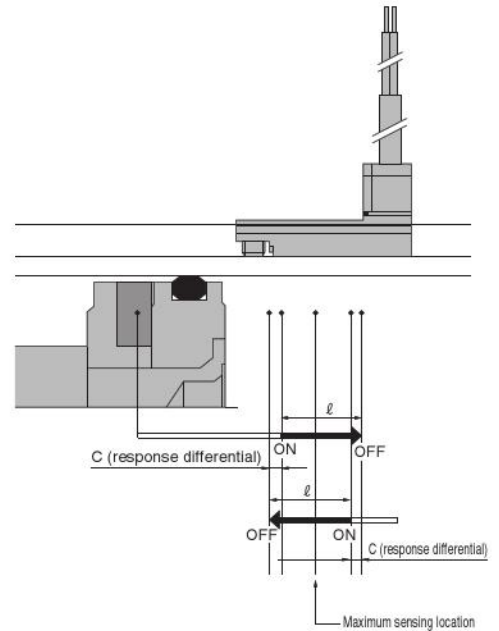

Mounting Position of the End of Stroke Detection Sensor Switch

Mounting the sensor switch in the locations shown (values in diagram are reference values), the sensor magnet comes to the maximum sensing location of the sensor switch at the end of the stroke.

● Low friction cylinders

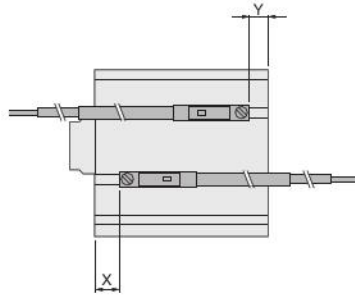

■ Solid State Type

● Double acting type

		mm [in]								
Code	Bore	6 [0.236]	8 [0.315]	10 [0.394]	12 [0.472]	16 [0.630]	20 [0.787]	25 [0.984]	32 [1.260]	40 [1.575]
X		6.5 [0.256]	7.5 [0.295]	8 [0.315]	10 [0.394]	10 [0.394]	15 [0.591]	15 [0.591]	15 [0.591]	16 [0.630]
Y		0.4 [0.016]	0.5 [0.020]	1 [0.039]	6 [0.236]	5 [0.197]	8 [0.315]	9 [0.354]	6 [0.236]	8 [0.315]

■ Reed Switch Type

● Double acting type

		mm [in]								
Code	Bore	6 [0.236]	8 [0.315]	10 [0.394]	12 [0.472]	16 [0.630]	20 [0.787]	25 [0.984]	32 [1.260]	40 [1.575]
X		—	—	—	5.5 [0.217]	6 [0.236]	10.5 [0.413]	11 [0.433]	11 [0.433]	12 [0.472]
Y		—	—	—	1.5 [0.059]	1 [0.039]	4 [0.157]	5 [0.197]	2 [0.079]	4 [0.157]

● Clean specification low friction cylinders

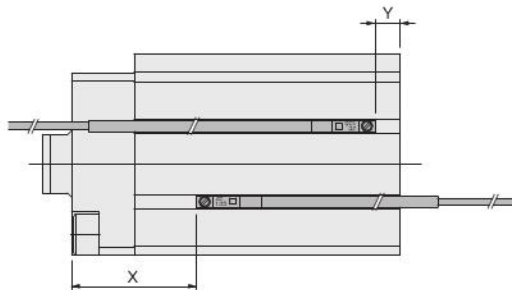

■ Solid State Type

● Double acting type

		mm [in]								
Code	Bore	6 [0.236]	8 [0.315]	10 [0.394]	12 [0.472]	16 [0.630]	20 [0.787]	25 [0.984]	32 [1.260]	40 [1.575]
X		11.5 [0.453]	12.5 [0.492]	13 [0.512]	20 [0.787]	20 [0.787]	25 [0.984]	25 [0.984]	30 [1.181]	31 [1.220]
Y		0.4 [0.016]	0.5 [0.020]	1 [0.039]	6 [0.236]	5 [0.197]	8 [0.315]	9 [0.354]	6 [0.236]	8 [0.315]

■ Reed Switch Type

● Double acting type

		mm [in]								
Code	Bore	6 [0.236]	8 [0.315]	10 [0.394]	12 [0.472]	16 [0.630]	20 [0.787]	25 [0.984]	32 [1.260]	40 [1.575]
X		—	—	—	15.5 [0.610]	16 [0.630]	20.5 [0.807]	21 [0.827]	26 [1.024]	27 [1.063]
Y		—	—	—	1.5 [0.059]	1 [0.039]	4 [0.157]	5 [0.197]	2 [0.079]	4 [0.157]

