

Koganei Clean System products provide complete support for the maintenance of a clean environment inside the cleanroom.

Koganei Clean System products meet the needs of the ultra-clean production environment. In everything from actuators and valves to air preparation and auxiliary equipment, anti-corrosion materials processing and other Koganei-developed design concepts serve to prevent particle contamination within the cleanroom. These perfectly designed mechanisms, which resolve even the slightest leaks to the outside during operations, have already won a high level of reliability.

Koganei Cleanliness

There is currently no standard in JIS or elsewhere for methods of evaluating cleanliness for pneumatic equipment in the cleanroom specifications. Therefore, to measure the effects of cleanroom contamination by pneumatic equipment, Koganei has decided to use "number of particles generated per 10 operations," rather than particle density. Koganei has also developed classifications for application classes in cleanroom, based on JIS and other upper limit density tables, and on the company's own experience.



- Remarks:
1. In the above table, product performance in terms of the number of particles generated per 10 operations is expressed as the upper limit of particles corresponding to the equivalent JIS or ISO class.
 2. In the above table, values in the JIS, ISO, and FED-STD upper limit density tables are calculated as upper density per liter.
 3. The classes shown are clean levels as classified in JIS and ISO.

From the above definitions, the Koganei clean level classes can be viewed as the level of average contamination per liter of surrounding air over a period of 10 operations in cleanroom. Air ventilation in cleanrooms is usually faster than 1 cycle per minute, and clean volumetric capacity is usually larger than 1 liter, which should provide a sufficient safety margin in practice.

Caution: The above conclusions are based on an ideal situation in which air ventilation is being implemented. For specific cases where air ventilation is not ensured, caution is needed since the clean classes cannot be maintained.

The clean system diagrams shown here are for Class 5 equivalent products. For Class 4 or Class 3 equivalent products, consult us.

Evaluations of Cleanliness

Koganei has therefore specified its in-house measurement methods, to conduct evaluations on the cleanroom rating.

The number of particles of the Air Cylinder Cleanroom Specification is measured as shown in the method below.

1. Measurement conditions

1-1 Test circuit: Figure 1 (no suction), Figure 2 (with suction)

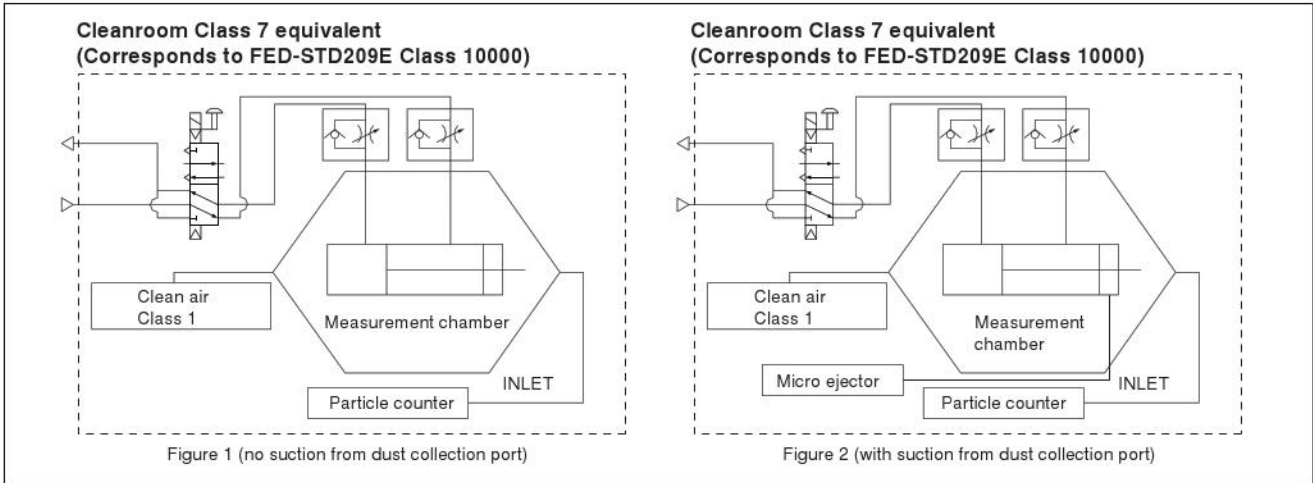

1-2 Operating conditions of tested cylinder

- Operating frequency: 1Hz
- Average speed: 500mm/s [20in./sec.]
- Applied pressure: 0.5MPa [73psi.]
- Suction condition: Microejector ME05, Primary side: 0.5MPa [73psi.] applied, Tube: $\phi 6$ [0.236in.]
- Mounting direction: Vertical
- Chamber volume: 8.3 ℓ [0.293ft³]

2. Particle counter

- Manufacturer/model: RION/KM20
- Suction flow rate: 28.3 ℓ /min [1ft³/min.]
- Particle diameter: 0.1 μm , 0.2 μm , 0.3 μm , 0.5 μm , 0.7 μm , 1.0 μm

3. Measurement method

- 3-1 Confirmation of number of particles in the measurement system
Under the conditions in the above 1 and 2, using a particle counter to measure the sample for 9 minutes without operating the measurement sample, and confirmed the measured number of particle is 1 piece or less.
- 3-2 Measurement under operation
Under the conditions in the above 1 and 2, operating the measurement sample for 36 minutes, and measured the total values in the latter half of 18 minutes test.
- 3-3 Reconfirmation
Performed the measurement in 3-1 again, to reconfirm the number of particles in the measurement system.

4. Measurement results

● Cleanroom specification

Jig Cylinder (no suction from dust collection port)

Particle generation over 1 million operations (CS-CDA16 \times 30)

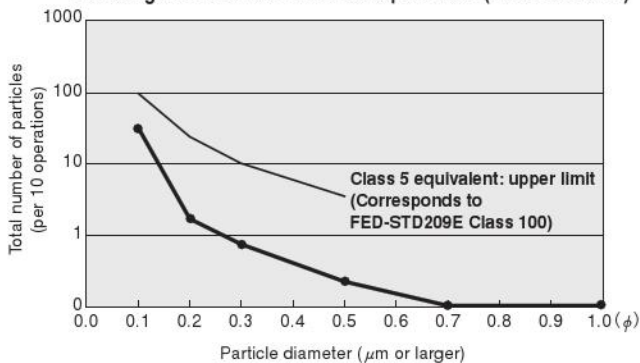

● Cleanroom specification

Slim Cylinder (with suction from dust collection port)

Particle generation over 1 million operations (CS-DA20 \times 100)

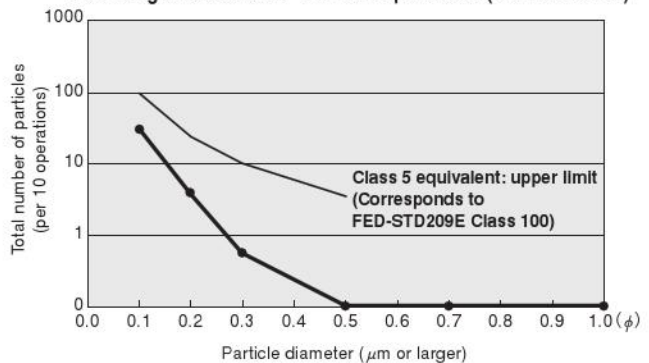

For "safety precautions" listed in the Clean System Product Drawings, see the materials below.

- For actuators, see "Safety Precautions" on p. 45 of the Actuators General Catalog .
- For valves, see "Safety Precautions" on p. 31 of the Valves General Catalog.
- For air treatment and auxiliary equipment, see "Safety Precautions" on p.31 of the General Catalog of Air Treatment, Auxiliary, Vacuum.

KOGANEI CLEAN SYSTEM SOLENOID VALVES 050 SERIES



Symbols

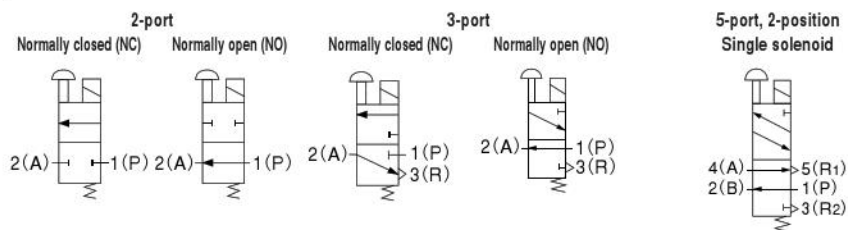

Specifications

Basic model	Standard type		Low current type		
	For direct piping SM type manifold	CS-050E1	CS-050-4E1	CS-050LE1	CS-050-4LE1
Item	For sub-base mounted unit	CS-A050E1	CS-A050-4E1	CS-A050LE1	CS-A050-4LE1
Number of positions	2 positions				
Number of ports	2, 3 ports	5 ports		2, 3 ports	5 ports
Valve function	Normally closed (NC, standard) or Normally open (NO, optional)	Single solenoid		Normally closed (NC, standard) or Normally open (NO, optional)	Single solenoid
Media	Air				
Operation type	Direct acting type				
Effective area [Cv]	mm ²	1.5 [0.08]	1.2 [0.07]	1.5 [0.08]	1.2 [0.07]
Port size	M5 × 0.8				
Lubrication	Not required				
Operating pressure range	MPa [psi.]	0 ~ 0.7 [0 ~ 102]			
Proof pressure	MPa [psi.]	1.05 [152]			
Response time ^{Note}	ms	20/20 or below		30/30 or below	
ON/OFF	DC24V	20/20 or below		30/30 or below	
	AC100V, AC200V	25/25 or below		—	
Maximum operating frequency	Hz	5			
Operating temperature range (atmosphere and media)	°C [°F]	0 ~ 50 [32 ~ 122]			
Shock resistance	Lateral direction	1373.0 [140]			
	Axial direction	294.2 [30]			
Mounting direction	Any				

Note: Values when air pressure is 0.5MPa [73 psi.].

Solenoid Specifications

Item	Rated voltage	Standard type				Low current type		
		DC24V	AC100V		AC200V		DC24V	
Type		DC type	Flywheel type				DC type	
Operating voltage range	V	21.6 ~ 26.4 (24 + 10%)	90 ~ 110 (100 + 10%)		180 ~ 220 (200 + 10%)		21.6 ~ 26.4 (24 + 10%)	
Current ^{Note 1} (when rated voltage is applied)	Frequency	—	50	60	50	60	—	
	Energizing ^{Note 2}	240 (5.8W) [252 (6.0W)]	74 [83]	71 [79]	48 [50]	46 [48]	100 (2.4W) [112 (2.7W)]	
Maximum allowable leakage current	mA	20	10		5		10	
Insulation resistance	MΩ	10					10	
Wiring type and lead wire length	Standard	Grommet type: 300mm [11.8in.]					Grommet type: 300mm [11.8in.]	
	Optional	With DIN connector					With DIN connector	
Color of lead wire		Red (Red(+), Blue(-)) ^{Note 1} Red(+), Black(-) ^{Note 3}	Yellow, Black		White, Black		Red (Red(+), Blue(-)) ^{Note 1} Red(+), Black(-) ^{Note 3}	
Color of LED indicator (optional)		Red	Yellow		Green		Red	
Surge suppression	Standard	—					—	
	Optional	Flywheel diode	—		Flywheel diode		Flywheel diode	

Notes: 1. Figures in brackets [] are for solenoids with LED indicators.

2. Since the AC types have built-in flywheel diodes, the starting current value is virtually the same as the energizing current value.

3. For solenoids with surge suppression, and solenoids with surge suppression and LED indicators.

Inner Construction and Major Parts

CS-A050E1-25

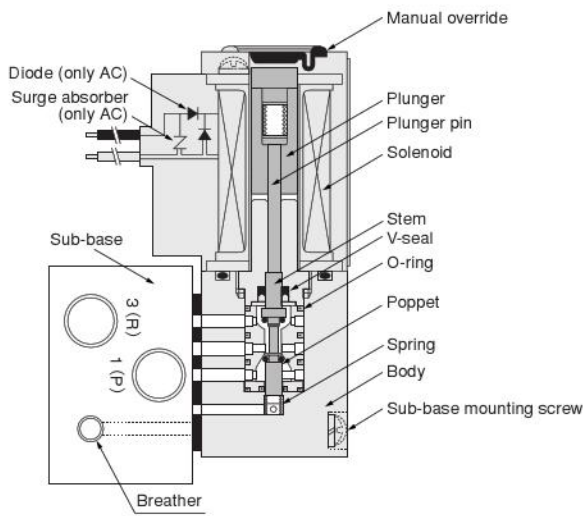

CS-A050E1-11-25

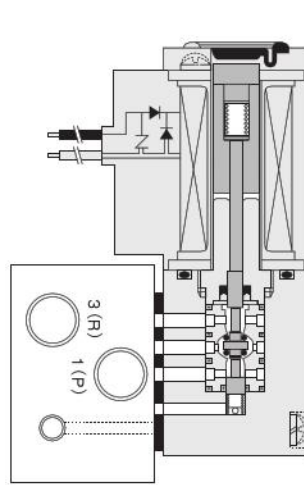

CS-A050LE1-25

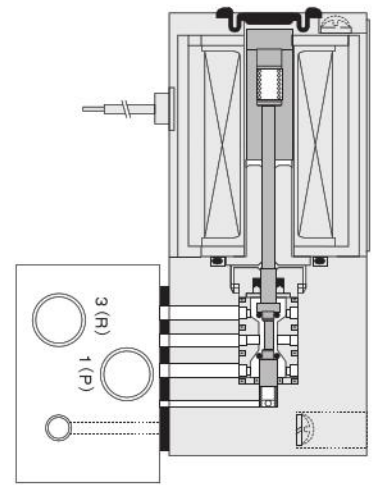

CS-A050-4E1-25

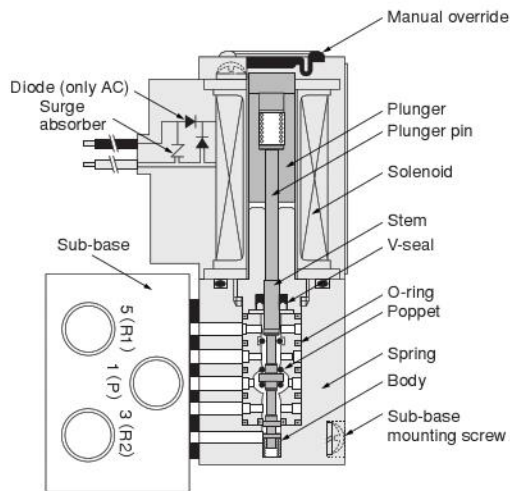

CS-A050-4LE1-25

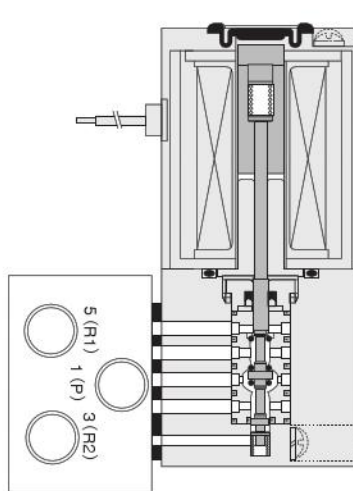

Major Parts Materials

Parts	Materials
Body	Aluminum alloy (anodized)
Sub-base	
Stem	Brass
Stem spring	Piano wire
Seal	Synthetic rubber (NBR)
Plunger	Stainless steel
Mounting screw	Mild steel (nickel plated)

Manifold Materials

Parts	Materials
Body	Aluminum alloy (anodized)
Block-off plate	Mild steel (nickel plated)
Seal	Synthetic rubber (NBR)
Mounting screw	Mild steel (nickel plated)

Order Codes

CS - A 050E1									
Clean system 050 series valve basic model									
		Port size		Number of ports		Valve function		Sub-base	
		M5×0.8	• P, A, B Rc1/8 • R M5×0.8	3-port	2-port	Normally closed (NC)	Normally open (NO)	Without sub-base	With sub-base
● For sub-base-mounted units (cannot be used for units without sub-base)	CS - A050E1	2-, 3-port		Blank	- 2	Blank	- 11	Blank	- 25 Sub-base piping type
	CS - A050-4E1	5-port		—		—			
	CS - A050LE1	2-, 3-port		Blank	- 2	Blank	- 11		
	CS - A050-4LE1	5-port		—		—			
● For manifold mounted units	CS - 050E1	2-, 3-port		Blank	- 01	Blank	- 2	Blank	Dedicated for manifold mounting
	CS - 050-4E1	5-port		—		—			
	CS - 050LE1	2-, 3-port		Blank	- 01	Blank	- 2		
	CS - 050-4LE1	5-port		—		—			

Manifold Order Codes

CS - SM			
Clean system 050 series manifold basic model			
CS-SM	Number of units	Station	Clean system mounting valve model
	<input type="text" value="2"/> : 2 units <input type="text" value="3"/> : 3 units ⋮ <input type="text" value="10"/> : 10 units	● Valve mounting position from left, as viewed from the front <input type="text" value="Stn.1"/> : First <input type="text" value="Stn.2"/> : Second ⋮ <input type="text" value="Stn.10"/> : 10th	● For details of valve models, see the order codes listed above. ● Enter CS-BP when closing a station with a block-off plate without mounting a valve.

Wiring type		LED indicator		Flywheel diode		Voltage
Grommet type	DIN connector	Without LED indicator	With LED indicator Not available with DIN connector	Without flywheel diode	With flywheel diode	
Blank	- 39	Blank	- LF	Blank	- SR	DC24V AC100V AC200V For DC24V only. Equipped for AC100V and AC200V as standard. For L type, only DC24V is available.
			- L			
Blank	- 39	Blank	- LF	Blank	- SR	
			- L			

Dimensions of Solenoid Valve mm [in.]

● CS-A050E1-25

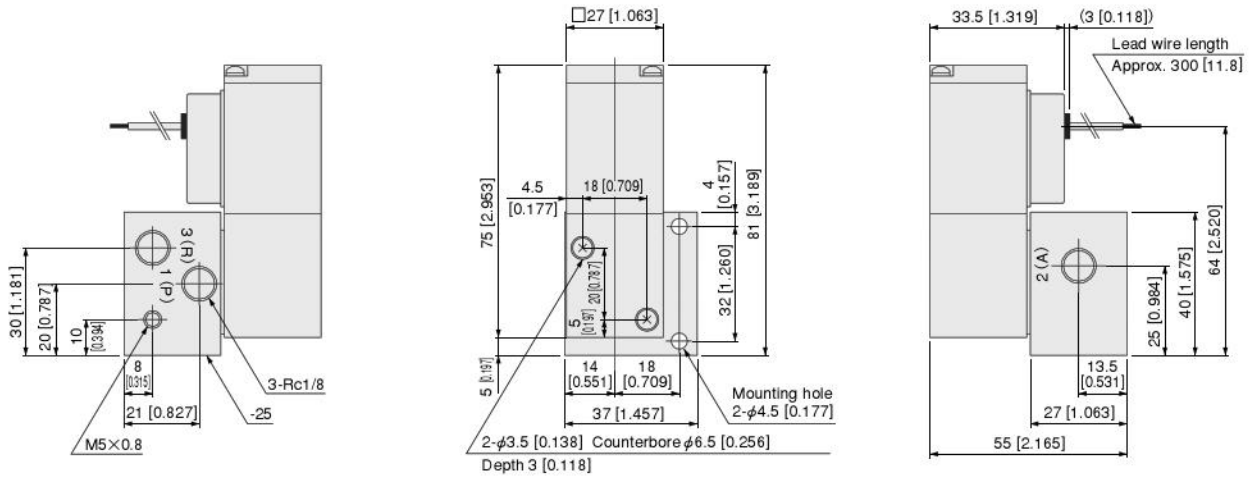

● CS-A050-4E1-25

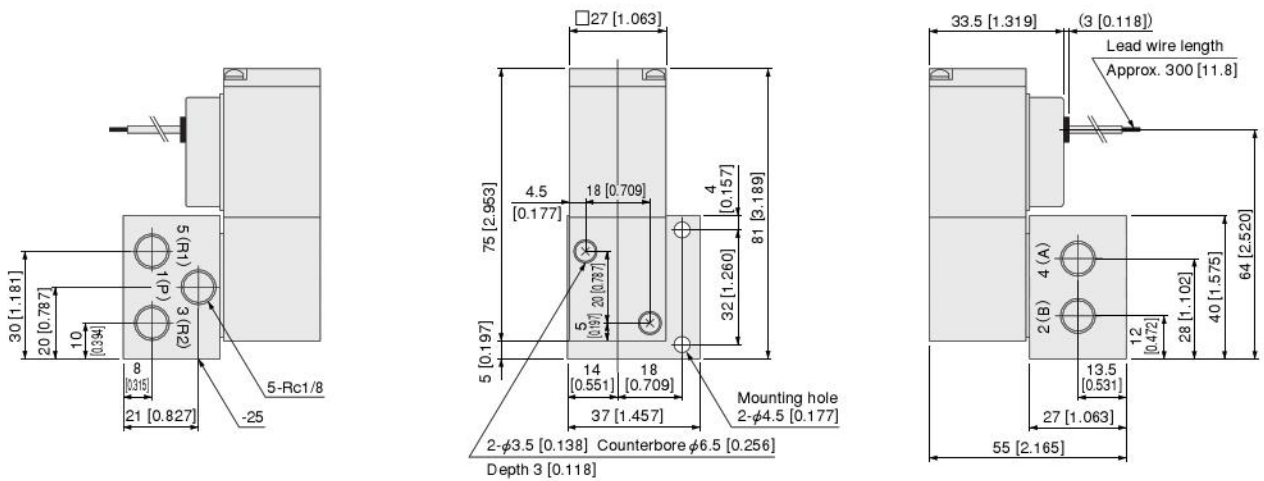

● Options

● Solenoid with DIN connector: **-39**
(Standard type)

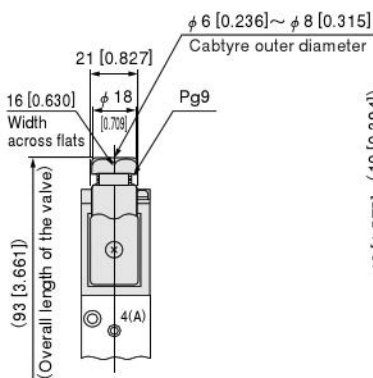

● Solenoid with LED indicator: **-LF**
(Standard type)

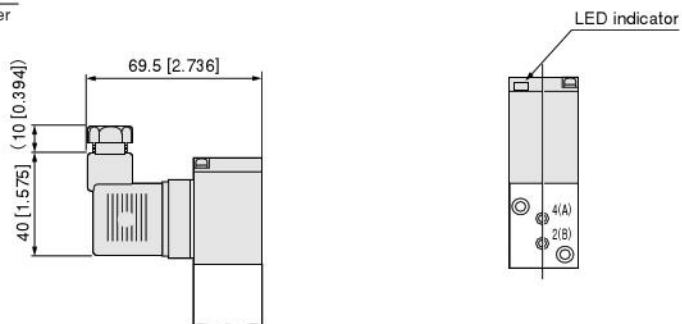

Dimensions of Solenoid Valve mm [in.]

● CS-A050LE1-25

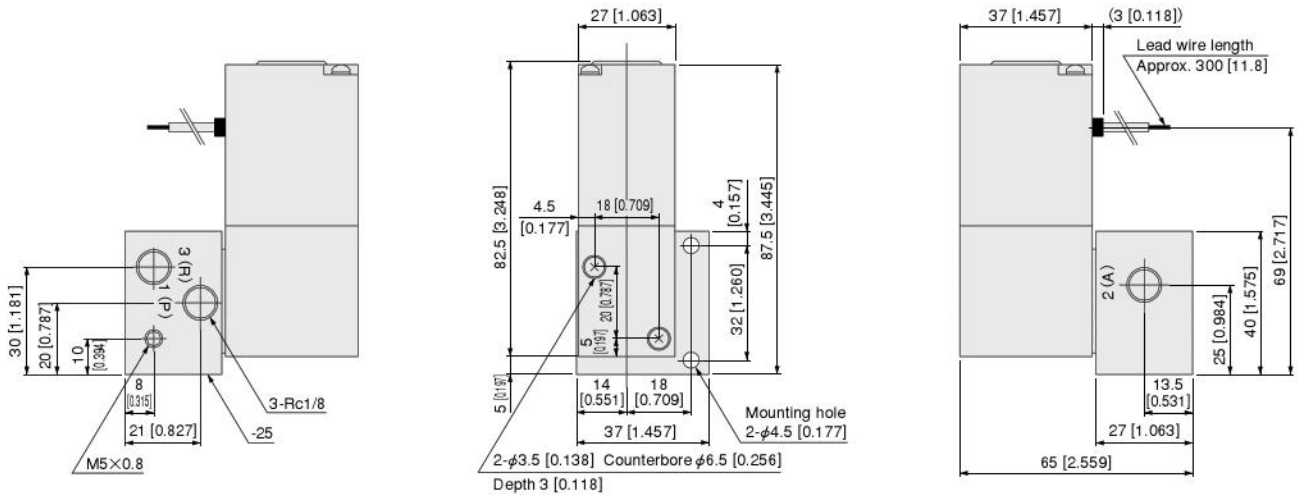

● CS-A050-4LE1-25

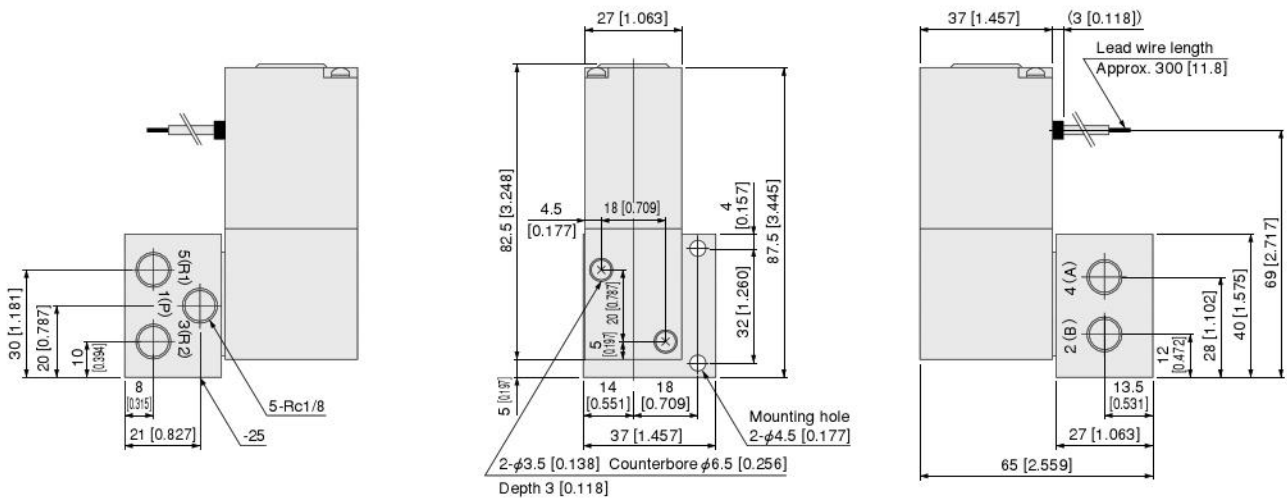

● Options

● Solenoid with DIN connector: **-39**
(Low current type)

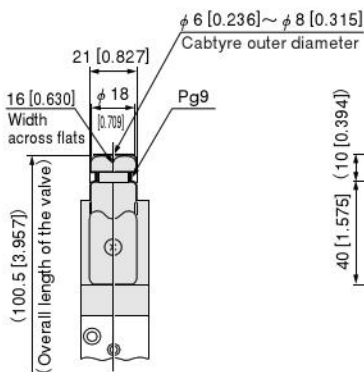

● Solenoid with LED indicator: **-L**
(Low current type)

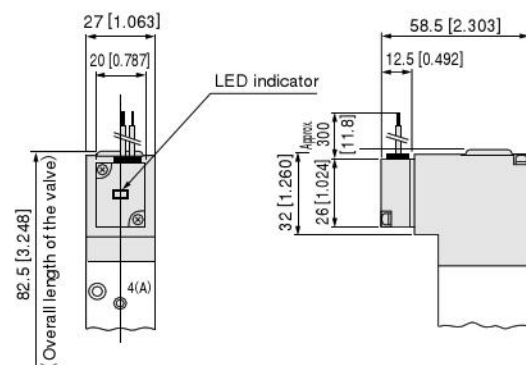

Dimensions of Manifold mm [in.]

Standard type

CS-SM (Mounting solenoid valve CS-050 series)

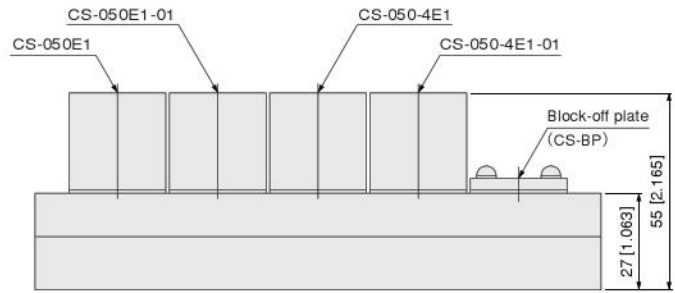
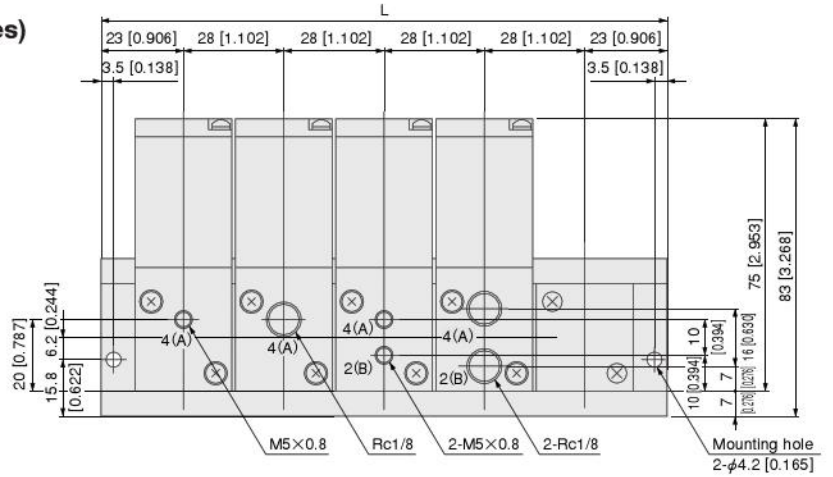
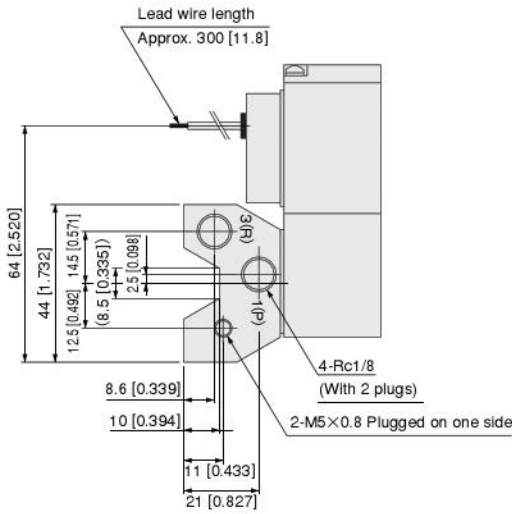

Unit dimensions

Model	L
CS-SM2	74 [2.913]
CS-SM3	102 [4.016]
CS-SM4	130 [5.118]
CS-SM5	158 [6.220]
CS-SM6	186 [7.323]
CS-SM7	214 [8.425]
CS-SM8	242 [9.528]
CS-SM9	270 [10.630]
CS-SM10	298 [11.732]

Low current type

CS-SM (Mounting solenoid valve CS-050L series)

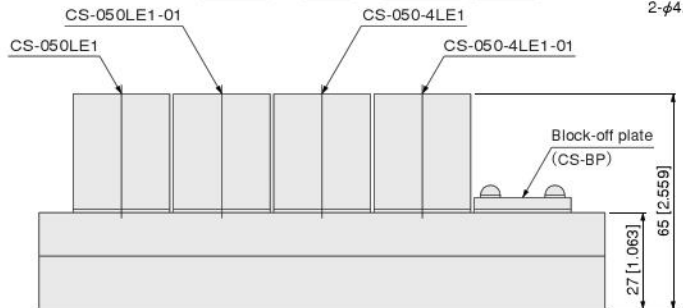
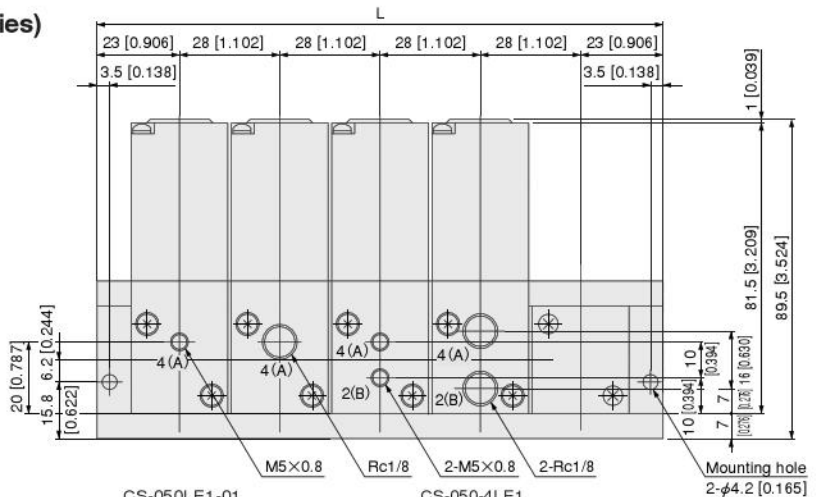
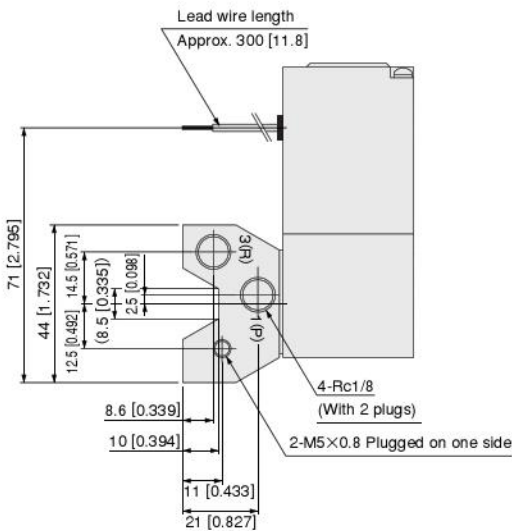

Unit dimensions

Model	L
CS-SM2	74 [2.913]
CS-SM3	102 [4.016]
CS-SM4	130 [5.118]
CS-SM5	158 [6.220]
CS-SM6	186 [7.323]
CS-SM7	214 [8.425]
CS-SM8	242 [9.528]
CS-SM9	270 [10.630]
CS-SM10	298 [11.732]