

CYLINDER ROD ENDS

Thread size M3 × 0.5 ~ M26 × 1.5

A flexible motion ensures cylinder functions!

- Eleven types are available by thread size.
Suitable for ϕ 6 [0.236in.] ~ ϕ 100 [3.940in.] bore cylinders.
- Because it uses a fluoro plastic liner, no lubrication is required and it is maintenance free.



Specifications

Model	Item	Thread size	Applicable cylinder and bore size					The max. cylinder thrust of applicable cylinder at 0.97Mpa N [lbf.]	Limit load ^{Note1}		Allowable radial static load N [lbf.]	Mass g [oz.]
			Pen	Multi mount	Jig C (male thread specification -B)	Slim	Twinport		DYNA	Radial load N [lbf.]		
CRE-3×0.5		M3×0.5	6	6	6	-	-	27.5 [6.2]	1380[310.2]	660[148.4]	1700[382.2]	10 [0.35]
CRE-4×0.7		M4×0.7	10	10	8, 10	-	-	76.5 [17.2]	2450[550.8]	1080[242.8]	2500[562]	12 [0.42]
CRE-5×0.8		M5×0.8	16	16	12	-	-	195.2 [43.9]	5860[1317.4]	2250[505.8]	8600[1933.4]	18 [0.63]
CRE-6×1		M6×1	-	-	16	16	16	305.0 [68.6]	6370[1432]	2450[550.8]	9800[2203.1]	26 [0.92]
CRE-8×1		M8×1	-	-	20	20, 25 ^{Note2}	20	475.6 [106.9]	7840[1762.5]	2940[660.9]	11800[2652.7]	45 [1.59]
CRE-10×1.25		M10×1.25	-	-	25	25, 32	25, 32	780.6 [175.5]	10290[2313.3]	3820[858.8]	15200[3417.1]	76 [2.68]
CRE-12×1.25		M12×1.25	-	-	-	-	-	780.6 [175.5]	12740[2864.1]	4900[1101.5]	19100[4293.9]	114 [4.02]
CRE-14×1.5		M14×1.5	-	-	32, 40	40, 50, 63	40	3026.3 [680.3]	16660[3745.3]	6370[1432]	25000[5620.2]	158 [5.57]
CRE-18×1.5		M18×1.5	-	-	50, 63	-	50, 63	3026.3 [680.3]	24990[5618]	9310[2093]	37200[8362.9]	288 [10.16]
CRE-22×1.5		M22×1.5	-	-	80	-	80	4879.8 [1097]	34790[7821.1]	13230[2974.2]	51900[11667.6]	475 [16.76]
CRE-26×1.5		M26×1.5	-	-	100	-	100	7623.7 [1714]	44100[9914.1]	27730[6234]	69600[15646.7]	673 [23.74]

Notes: 1. For the square rod cylinders.
2. Only for the block cylinders.

Order Codes

CRE —

Cylinder rod end	Thread size	
3 × 0.5	M3 × 0.5	(Hole diameter for pin ϕ 3 [0.118in.])
4 × 0.7	M4 × 0.7	(Hole diameter for pin ϕ 4 [0.157in.])
5 × 0.8	M5 × 0.8	(Hole diameter for pin ϕ 5 [0.197in.])
6 × 1	M6 × 1	(Hole diameter for pin ϕ 6 [0.236in.])
8 × 1	M8 × 1	(Hole diameter for pin ϕ 8 [0.315in.])
10 × 1.25	M10 × 1.25	(Hole diameter for pin ϕ 10 [0.394in.])
12 × 1.25	M12 × 1.25	(Hole diameter for pin ϕ 12 [0.472in.])
14 × 1.5	M14 × 1.5	(Hole diameter for pin ϕ 14 [0.551in.])
18 × 1.5	M18 × 1.5	(Hole diameter for pin ϕ 18 [0.709in.])
22 × 1.5	M22 × 1.5	(Hole diameter for pin ϕ 22 [0.866in.])
26 × 1.5	M26 × 1.5	(Hole diameter for pin ϕ 25 [0.984in.])

Inner Construction, Major Parts and Materials

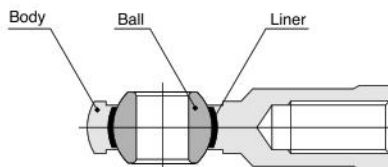

Parts	Materials
Body	Carbon steel (zinc plated)
Ball	Bearing steel (chrome plated)
Liner	Fluoro plastic

Mounting Examples

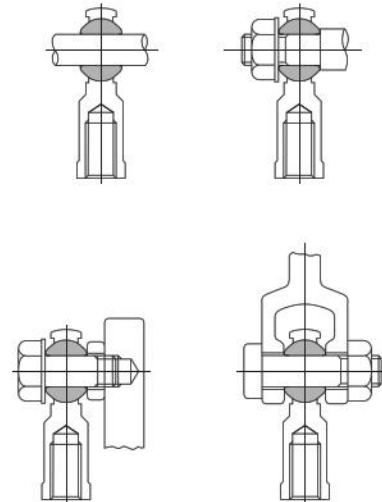

Dimensions (mm)

● CRE-3 × 0.5 ~ 26 × 1.5

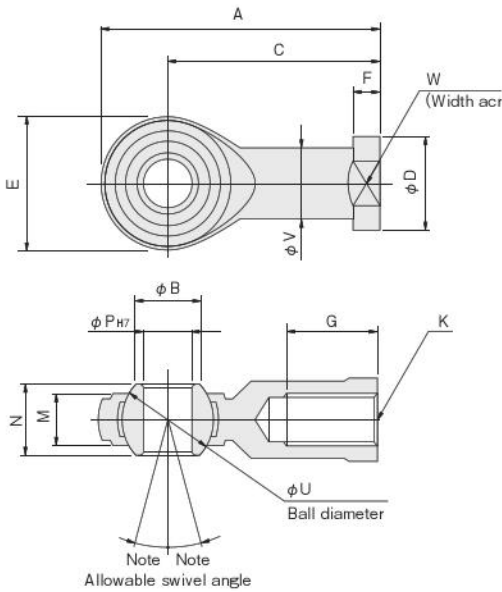

Note: The allowable swivel angle varies depending on the mating shaft.
For details, see the table in Handling Instructions and Precautions.

Model	Code	A	B	C	D	E	F	G	K	M	N	P	U	V	W
CRE-3 × 0.5		27	5.2	21	8	12	3	10	M3 × 0.5	4.5	6 ^{-0.13} ₀	3	7.938	6.5	7
CRE-4 × 0.7		31	6.5	24	9.5	14	4	12	M4 × 0.7	5.2	7 ^{-0.13} ₀	4	9.525	8	8
CRE-5 × 0.8		35	7.7	27	11	16	4	12	M5 × 0.8	6	8 ^{-0.13} ₀	5	11.11	9	9
CRE-6 × 1		39	9	30	13	18	5	14	M6 × 1	6.7	9 ^{-0.1} ₀	6	12.7	10	11
CRE-8 × 1		47	10.4	36	16	22	5	19	M8 × 1	9	12 ^{-0.1} ₀	8	15.88	12.5	14
CRE-10 × 1.25		56	12.9	43	19	26	6.5	21	M10 × 1.25	11	14 ^{-0.1} ₀	10	19.05	15	17
CRE-12 × 1.25		65	15.4	50	22	30	6.5	24	M12 × 1.25	12	16 ^{-0.1} ₀	12	22.225	17.5	19
CRE-14 × 1.5		74	16.8	57	25	34	8	27	M14 × 1.5	14	19 ^{-0.1} ₀	14	25.4	20	22
CRE-18 × 1.5		92	21.8	71	31	42	10	36	M18 × 1.5	17	23 ^{-0.1} ₀	18	31.75	25	27
CRE-22 × 1.5		109	25.8	84	37	50	12	43	M22 × 1.5	20	28 ^{-0.1} ₀	22	38.1	30	32
CRE-26 × 1.5		122	29.6	94	42	56	12	48	M26 × 1.5	22	31 ^{-0.1} ₀	25	42.86	33.5	36

Handling Instructions and Precautions

- The cylinder rod end is for the air cylinder only. Consult us for any use other than for the air cylinder.
- It cannot be disassembled.
- Because it uses a fluoro plastic liner, no lubrication is required and it is maintenance free.
- The ball rotates in any direction, but do not use the cylinder rod end exceeding allowable swivel angle. Moreover, the allowable swivel angle varies depending on the mating shaft. See the table below.

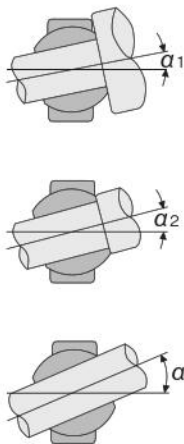

Allowable swivel angle

Model	α1	α2	α3
CRE-3 × 0.5	8°	15°	33°
CRE-4 × 0.7	8°	14°	32°
CRE-5 × 0.8	9°	13°	30°
CRE-6 × 1	9°	13°	29°
CRE-8 × 1	9°	15°	25°
CRE-10 × 1.25	8°	12°	23°
CRE-12 × 1.25	9°	13°	24°
CRE-14 × 1.5	10°	15°	23°
CRE-18 × 1.5	9°	14°	23°
CRE-22 × 1.5	10°	16°	23°
CRE-26 × 1.5	11°	15°	23°