

***Square body demonstrates powerful downsizing capacity.***

# JIG CYLINDERS C SERIES

***Richly abundant series of 9 different types and 69 models***

A rich series configuration spanning from  $\phi 6$  [0.236in.] to  $\phi 100$  [3.940in.] responds to diverse needs far better than previous thin type cylinders. Moreover, Non-ion specification is also available as standard.  
(Excludes  $\phi 6$  [0.236in.],  $\phi 8$  [0.315in.], and  $\phi 10$  [0.394in.]

***Provides powerful back-up for device miniaturization***

Exhibits no protrusions in its external shape even after a sensor switch has been mounted, for easy mounting in tight spaces. This cylinder is one step up on cylinders of the same class in terms of size, mass, and performance.



$\phi 6$   
[0.236in.]

$\phi 100$   
[3.940in.]



## **New Line-Up Includes $\phi 6$ [0.236in.], $\phi 8$ [0.315in.], and $\phi 10$ [0.394in.]**

For a greater selection in response to needs for miniaturization, 3 new bore sizes at  $\phi 6$ ,  $\phi 8$ , and  $\phi 10$  have been added, increasing the range of sizes to choose from.



Standard Cylinders

$\phi 6$  [0.236in.]~ $\phi 100$  [3.940in.]



Non-rotating Cylinders

$\phi 6$  [0.236in.]~ $\phi 10$  [0.394in.]

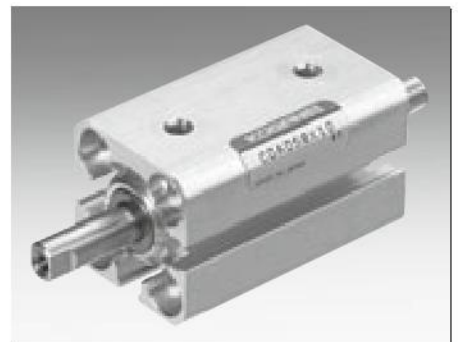

Double Rod Cylinders

$\phi 6$  [0.236in.]~ $\phi 100$  [3.940in.]

## The Jig Cylinders C Series Includes the 9 Types Shown Below.

■ Standard Cylinders

p.137



■ Non-rotating Cylinders

p.145



■ Square Rod Cylinders

p.149



■ Double Rod Cylinders

p.154



■ Tandem Cylinders

p.161



■ Dual Stroke Cylinders

p.170



■ Lateral Load Resistant Cylinders

p.180



■ Long Stroke Cylinders

p.185



■ End Keep Cylinders

p.190



■ Mounting Brackets

p.197



■ Sensor Switches

p.199



	Operation type			Cylinder specifications		Rod end specifications		Bumpers	Centering location	Non-BN specification	Mounting brackets		
	Double acting type	Single acting push type	Single acting pull type	Cylinder with magnet	Heat resistant type	Female thread	Male thread	Not available for heat resistant type		Not available for heat resistant type	Foot mounting bracket	Flange mounting bracket	Clevis mounting bracket
Standard Cylinders	<input checked="" type="checkbox"/>	<input checked="" type="checkbox"/>	<input checked="" type="checkbox"/>	<input checked="" type="checkbox"/>	<input checked="" type="checkbox"/>	<input checked="" type="checkbox"/>	<input checked="" type="checkbox"/>	<input checked="" type="checkbox"/>	<input checked="" type="checkbox"/>	<input checked="" type="checkbox"/>	<input checked="" type="checkbox"/>	<input checked="" type="checkbox"/>	<input checked="" type="checkbox"/>
Non-rotating Cylinders	Note			Note		Note	Note						
Square Rod Cylinders	<input checked="" type="checkbox"/>			<input checked="" type="checkbox"/>		<input checked="" type="checkbox"/>	<input checked="" type="checkbox"/>	<input checked="" type="checkbox"/>	<input checked="" type="checkbox"/>	<input checked="" type="checkbox"/>	<input checked="" type="checkbox"/>	<input checked="" type="checkbox"/>	<input checked="" type="checkbox"/>
Double Rod Cylinders	<input checked="" type="checkbox"/>	<input checked="" type="checkbox"/>		<input checked="" type="checkbox"/>	<input checked="" type="checkbox"/>	<input checked="" type="checkbox"/>	<input checked="" type="checkbox"/>	<input checked="" type="checkbox"/>	<input checked="" type="checkbox"/>	<input checked="" type="checkbox"/>	<input checked="" type="checkbox"/>	<input checked="" type="checkbox"/>	<input checked="" type="checkbox"/>
Tandem Cylinders	<input checked="" type="checkbox"/>	<input checked="" type="checkbox"/>		<input checked="" type="checkbox"/>	<input checked="" type="checkbox"/>	<input checked="" type="checkbox"/>	<input checked="" type="checkbox"/>	<input checked="" type="checkbox"/>	<input checked="" type="checkbox"/>	<input checked="" type="checkbox"/>		<input checked="" type="checkbox"/>	
Dual Stroke Cylinders	<input checked="" type="checkbox"/>	<input checked="" type="checkbox"/>	<input checked="" type="checkbox"/>	<input checked="" type="checkbox"/>		<input checked="" type="checkbox"/>	<input checked="" type="checkbox"/>	<input checked="" type="checkbox"/>	<input checked="" type="checkbox"/>	<input checked="" type="checkbox"/>		<input checked="" type="checkbox"/>	
Lateral Load Resistant Cylinders	<input checked="" type="checkbox"/>			<input checked="" type="checkbox"/>		<input checked="" type="checkbox"/>	<input checked="" type="checkbox"/>	<input checked="" type="checkbox"/>	<input checked="" type="checkbox"/>	<input checked="" type="checkbox"/>	<input checked="" type="checkbox"/>	<input checked="" type="checkbox"/>	<input checked="" type="checkbox"/>
Long Stroke Cylinders	<input checked="" type="checkbox"/>			<input checked="" type="checkbox"/>		<input checked="" type="checkbox"/>	<input checked="" type="checkbox"/>	<input checked="" type="checkbox"/>	<input checked="" type="checkbox"/>	<input checked="" type="checkbox"/>	<input checked="" type="checkbox"/>	<input checked="" type="checkbox"/>	<input checked="" type="checkbox"/>
End Keep Cylinders	<input checked="" type="checkbox"/>			<input checked="" type="checkbox"/>		<input checked="" type="checkbox"/>	<input checked="" type="checkbox"/>	<input checked="" type="checkbox"/>	<input checked="" type="checkbox"/>	<input checked="" type="checkbox"/>	<input checked="" type="checkbox"/>	<input checked="" type="checkbox"/>	<input checked="" type="checkbox"/>

■ The colored areas include bore sizes of  $\phi 6$ ,  $\phi 8$ , and  $\phi 10$ .

Note: Non-rotating cylinders are set at bore sizes  $\phi 6$ ,  $\phi 8$ , and  $\phi 10$  only.

# Cylinder Thrust

Select a suitable bore size considering the load and air pressure to obtain the required thrust.

Since the figures in the table are calculated values, select a bore size that results in a load ratio (load ratio =  $\frac{\text{Load}}{\text{Calculated value}}$ ) of 70% or less (50% or less for high speed).

## ● Double acting type

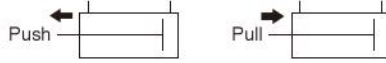

Bore size mm [in.]	Piston rod diameter mm [in.]	Operation	Pressure area mm <sup>2</sup> [in. <sup>2</sup> ]	Air pressure MPa [psi.]									
				0.1 [15]	0.2 [29]	0.3 [44]	0.4 [58]	0.5 [73]	0.6 [87]	0.7 [102]	0.8 [116]	0.9 [131]	1.0 [145]
<b>6 [0.236]</b>	4 [0.157]	Push side	28.3 [0.0439]	2.8 [0.63]	5.7 [1.28]	8.5 [1.91]	11.3 [2.54]	14.1 [3.17]	17.0 [3.82]	19.8 [4.45]	22.6 [5.08]	25.4 [5.71]	—
		Pull side	15.7 [0.0243]	1.6 [0.36]	3.1 [0.7]	4.7 [1.06]	6.3 [1.42]	7.9 [1.78]	9.4 [2.11]	11.0 [2.47]	12.6 [2.83]	14.1 [3.17]	—
<b>8 [0.315]</b>	5 [0.197]	Push side	50.3 [0.0780]	5.0 [1.12]	10.1 [2.27]	15.1 [3.39]	20.1 [4.52]	25.1 [5.64]	30.2 [6.79]	35.2 [7.91]	40.2 [9.04]	45.2 [10.2]	—
		Pull side	30.6 [0.0474]	3.1 [0.70]	6.1 [1.37]	9.2 [2.07]	12.3 [2.77]	15.3 [3.44]	18.4 [4.14]	21.4 [4.81]	24.5 [5.51]	27.6 [6.20]	—
<b>10 [0.394]</b>	5 [0.197]	Push side	78.5 [0.1217]	7.9 [1.78]	15.7 [3.53]	23.6 [5.31]	31.4 [7.06]	39.3 [8.83]	47.1 [10.6]	55.0 [12.4]	62.8 [14.1]	70.7 [15.9]	—
		Pull side	58.9 [0.0913]	5.9 [1.33]	11.8 [2.65]	17.7 [3.98]	23.6 [5.31]	29.5 [6.63]	35.3 [7.94]	41.2 [9.26]	47.1 [10.6]	53.0 [11.9]	—
<b>12 [0.472]</b>	6 [0.236]	Push side	113.0 [0.175]	11.3 [2.54]	22.6 [5.08]	33.9 [7.62]	45.2 [10.2]	56.5 [12.7]	67.8 [15.2]	79.1 [17.8]	90.4 [20.3]	101.7 [22.86]	113.0 [25.40]
		Pull side	84.8 [0.131]	8.5 [1.91]	17.0 [3.82]	25.4 [5.71]	33.9 [7.62]	42.4 [9.53]	50.9 [11.4]	59.3 [13.3]	67.8 [15.2]	76.3 [17.2]	84.8 [19.1]
<b>16 [0.630]</b>	8 [0.315]	Push side	201.0 [0.312]	20.1 [4.52]	40.2 [9.04]	60.3 [13.6]	80.4 [18.1]	100.5 [22.59]	120.6 [27.11]	140.7 [31.63]	160.8 [36.15]	180.9 [40.67]	201.0 [45.18]
		Pull side	150.0 [0.233]	15.1 [3.39]	30.1 [6.77]	45.2 [10.2]	60.3 [13.6]	75.4 [16.9]	90.4 [20.3]	105.5 [23.72]	120.6 [27.11]	135.6 [30.48]	150.7 [33.88]
<b>20 [0.787]</b>	10 [0.394]	Push side	314.0 [0.487]	31.4 [7.06]	62.8 [14.1]	94.2 [21.2]	125.6 [28.23]	157.0 [35.29]	188.4 [42.35]	219.8 [49.41]	251.2 [56.47]	282.6 [63.53]	314.0 [70.59]
		Pull side	235.5 [0.365]	23.6 [5.31]	47.1 [10.6]	70.7 [15.9]	94.2 [21.2]	117.8 [26.48]	141.3 [31.76]	164.9 [37.07]	188.4 [42.35]	212.0 [47.66]	235.5 [52.94]
<b>25 [0.984]</b>	12 [0.472]	Push side	490.6 [0.760]	49.1 [11.0]	98.1 [22.1]	147.2 [33.09]	196.3 [44.13]	245.3 [55.14]	294.4 [66.18]	343.4 [77.20]	392.5 [88.23]	441.6 [99.27]	490.6 [110.3]
		Pull side	377.6 [0.585]	37.8 [8.50]	75.5 [17.0]	113.3 [25.47]	151.0 [33.94]	188.8 [42.44]	226.6 [50.94]	264.3 [59.41]	302.1 [67.91]	339.8 [76.39]	377.6 [84.88]
<b>32 [1.260]</b>	16 [0.630]	Push side	803.8 [1.246]	80.4 [18.1]	160.8 [36.15]	241.2 [54.22]	321.5 [72.27]	401.9 [90.35]	482.3 [108.4]	562.7 [126.5]	643.1 [144.6]	723.5 [162.6]	803.8 [180.7]
		Pull side	602.9 [0.934]	60.3 [13.6]	120.6 [27.11]	180.9 [40.67]	241.2 [54.22]	301.4 [67.75]	361.7 [81.31]	422.0 [94.87]	482.3 [108.4]	542.6 [122.0]	602.9 [135.5]
<b>40 [1.575]</b>	16 [0.630]	Push side	1256.0 [1.947]	125.6 [28.23]	251.2 [56.47]	376.8 [84.70]	502.4 [112.9]	628.0 [141.2]	753.6 [169.4]	879.2 [197.6]	1004.8 [225.9]	1130.4 [254.1]	1256.0 [282.3]
		Pull side	1055.0 [1.635]	105.5 [23.72]	211.0 [47.43]	316.5 [71.15]	422.0 [94.87]	527.5 [118.6]	633.0 [142.3]	738.5 [166.0]	844.0 [189.7]	949.5 [213.4]	1055.0 [237.2]
<b>50 [1.969]</b>	20 [0.787]	Push side	1962.5 [3.042]	196.3 [44.13]	392.5 [88.23]	588.8 [132.4]	785.0 [176.5]	981.3 [220.6]	1177.5 [264.7]	1373.8 [308.8]	1570.0 [352.9]	1766.3 [397.1]	1962.5 [441.2]
		Pull side	1648.5 [2.555]	164.9 [37.07]	329.7 [74.12]	494.6 [111.2]	659.4 [148.2]	824.3 [185.3]	989.1 [222.3]	1154.0 [259.4]	1318.8 [296.5]	1483.7 [333.5]	1648.5 [370.6]
<b>63 [2.480]</b>	20 [0.787]	Push side	3115.7 [4.829]	311.6 [70.05]	623.1 [140.1]	934.7 [210.1]	1246.3 [280.2]	1557.8 [350.2]	1869.4 [420.2]	2181.0 [490.3]	2492.5 [560.3]	2804.1 [630.4]	3115.7 [700.4]
		Pull side	2801.7 [4.343]	280.2 [62.99]	560.3 [126.0]	840.5 [188.9]	1120.7 [251.9]	1400.8 [314.9]	1681.0 [377.9]	1961.2 [440.9]	2241.3 [503.8]	2521.5 [566.8]	2801.7 [629.8]
<b>80 [3.150]</b>	25 [0.984]	Push side	5024.0 [7.787]	502.4 [112.9]	1004.8 [225.9]	1507.2 [338.8]	2009.6 [451.8]	2512.0 [564.7]	3014.4 [677.6]	3516.8 [790.6]	4019.2 [903.5]	4521.6 [1016.5]	5024.0 [1129.4]
		Pull side	4533.4 [7.027]	453.3 [101.9]	906.7 [203.8]	1360.0 [305.7]	1813.4 [407.7]	2266.7 [509.6]	2720.0 [611.5]	3173.4 [713.4]	3626.7 [815.3]	4080.0 [917.2]	4533.4 [1019.1]
<b>100 [3.940]</b>	32 [1.181]	Push side	7850.0 [12.168]	785.0 [176.5]	1570.0 [352.9]	2355.0 [529.4]	3140.0 [705.9]	3925.0 [882.3]	4710.0 [1058.8]	5495.0 [1235.3]	6280.0 [1411.7]	7065.0 [1588.2]	7850.0 [1764.7]
		Pull side	7046.2 [10.922]	704.6 [158.4]	1409.2 [316.8]	2113.8 [475.2]	2818.5 [633.6]	3523.1 [792.0]	4227.7 [950.4]	4932.3 [1108.8]	5636.9 [1267.2]	6341.5 [1425.6]	7046.2 [1584.0]

## ● Single acting type

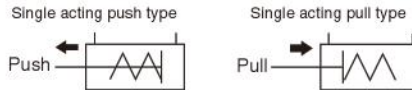

Operation type	Bore size mm [in.]	Piston rod diameter mm [in.]	Pressure area mm <sup>2</sup> [in. <sup>2</sup> ]	Air pressure MPa [psi.]									
				0.1 [15]	0.2 [29]	0.3 [44]	0.4 [58]	0.5 [73]	0.6 [87]	0.7 [102]	0.8 [116]	0.9 [131]	1.0 [145]
Single acting push type	<b>6 [0.236]</b>	4 [0.157]	28.3 [0.0439]	—	—	5.6 [1.26]	8.4 [1.89]	11.2 [2.52]	14.1 [3.17]	16.9 [3.80]	19.7 [4.43]	22.5 [5.06]	—
	<b>8 [0.315]</b>	5 [0.197]	50.3 [0.0780]	—	—	10.4 [2.34]	15.4 [3.46]	20.4 [4.59]	25.5 [5.73]	30.5 [6.86]	35.5 [7.98]	40.5 [9.10]	—
	<b>10 [0.394]</b>	5 [0.197]	78.5 [0.1217]	—	—	18.9 [4.25]	26.7 [6.00]	34.6 [7.78]	42.4 [9.53]	50.3 [11.3]	58.1 [13.1]	66.0 [14.8]	—
	<b>12 [0.472]</b>	6 [0.236]	113.0 [0.175]	—	12.8 [2.88]	24.1 [5.42]	35.4 [7.96]	46.7 [10.5]	58.0 [13.0]	69.3 [15.6]	80.6 [18.1]	91.9 [20.7]	103.2 [23.20]
	<b>16 [0.630]</b>	6 [0.236]	201.0 [0.312]	—	26.1 [5.87]	46.2 [10.4]	66.3 [14.9]	86.4 [19.4]	106.5 [23.94]	126.6 [28.46]	146.7 [32.98]	166.8 [37.50]	186.9 [42.02]
	<b>20 [0.787]</b>	8 [0.315]	314.0 [0.487]	—	49.0 [11.0]	80.4 [18.1]	111.8 [25.13]	143.2 [32.19]	174.6 [39.25]	206.0 [46.31]	237.4 [53.37]	268.8 [60.43]	300.2 [67.48]
	<b>25 [0.984]</b>	10 [0.394]	490.6 [0.760]	—	76.3 [17.2]	125.4 [28.19]	174.5 [39.23]	223.5 [50.24]	272.6 [61.28]	321.6 [72.30]	370.7 [83.33]	419.8 [94.37]	468.8 [105.4]
	<b>32 [1.260]</b>	12 [0.472]	803.8 [1.246]	—	123.4 [27.74]	203.8 [45.81]	284.1 [63.87]	364.5 [81.94]	444.9 [100.0]	525.3 [118.1]	605.7 [136.2]	686.1 [154.2]	766.4 [172.3]
	<b>40 [1.575]</b>	16 [0.630]	1256.0 [1.947]	—	205.9 [46.29]	331.5 [74.52]	457.1 [102.8]	582.7 [131.0]	708.3 [159.2]	833.9 [187.5]	959.5 [215.7]	1085.1 [243.9]	1210.5 [272.1]
	<b>50 [1.969]</b>	20 [0.787]	1962.5 [3.042]	141.0 [31.70]	337.2 [75.60]	533.5 [119.9]	729.7 [164.0]	926.0 [208.2]	1122.2 [252.3]	1318.5 [296.4]	1514.7 [340.5]	1711.0 [384.6]	1907.2 [428.7]
Single acting pull type	<b>6 [0.236]</b>	4 [0.157]	15.7 [0.0243]	—	—	1.8 [0.40]	3.4 [0.76]	5.0 [1.12]	6.5 [1.46]	8.1 [1.82]	9.7 [2.18]	11.2 [2.52]	—
	<b>8 [0.315]</b>	5 [0.197]	30.6 [0.0474]	—	—	4.5 [1.01]	7.6 [1.71]	10.6 [2.38]	13.7 [3.08]	16.7 [3.75]	19.8 [4.45]	22.9 [5.15]	—
	<b>10 [0.394]</b>	5 [0.197]	58.9 [0.0913]	—	—	13.0 [2.92]	18.9 [4.25]	24.8 [5.58]	30.6 [6.88]	36.5 [8.21]	42.4 [9.53]	48.3 [10.9]	—
	<b>12 [0.472]</b>	6 [0.236]	84.8 [0.131]	—	7.2 [1.62]	15.6 [3.51]	24.1 [5.42]	32.6 [7.33]	41.1 [9.24]	49.5 [11.1]	58.0 [13.0]	66.5 [14.9]	75.0 [16.9]
	<b>16 [0.630]</b>	6 [0.236]	150.7 [0.234]	—	16.0 [3.60]	31.1 [6.99]	46.2 [10.4]	61.3 [13.8]	76.3 [17.2]	91.4 [20.5]	106.5 [23.94]	121.5 [27.31]	136.6 [30.71]
	<b>20 [0.787]</b>	8 [0.315]	235.5 [0.365]	—	33.3 [7.49]	56.9 [12.8]	80.4 [18.1]	104.0 [23.38]	127.5 [28.66]	151.1 [33.97]	174.6 [39.25]	198.2 [44.56]	221.7 [49.84]
	<b>25 [0.984]</b>	10 [0.394]	377.6 [0.585]	—	75.5 [17.0]	113.3 [25.47]	151.0 [33.94]	188.8 [42.44]	226.6 [50.94]	264.3 [59.41]	302.1 [67.91]	339.8 [76.39]	377.6 [84.88]
	<b>32 [1.260]</b>	12 [0.472]	602.9 [0.934]	—	61.4 [13.8]	121.7 [27.36]	182.0 [40.91]	242.2 [54.45]	302.5 [68.00]	362.8 [81.56]	423.1 [95.11]	483.4 [108.7]	543.7 [122.2]
	<b>40 [1.575]</b>	16 [0.630]	1055.0 [1.635]	—	165.7 [37.25]	271.2 [60.97]	376.7 [84.68]	482.2 [108.4]	587.7 [132.1]	693.2 [155.8]	798.7 [179.5]	904.2 [203.3]	1009.7 [227.0]
	<b>50 [1.969]</b>	20 [0.787]	1648.5 [2.555]	109.6 [24.64]	274.4 [61.69]	439.3 [98.75]	604.1 [135.8]	769.0 [172.9]	933.8 [209.9]	1098.7 [247.0]	1263.5 [284.0]	1428.4 [321.1]	1593.2 [358.2]

● **Spring return force**

Bore size mm	Stroke mm	N [lbf.]	
		Zero stroke	End of stroke
6	× 5	2.1 [0.47]	2.9 [0.65]
	× 10	1.2 [0.27]	
8	× 5	3.3 [0.74]	4.7 [1.06]
	× 10	1.9 [0.43]	
10	× 5	3.3 [0.74]	4.7 [1.06]
	× 10	1.9 [0.43]	
12	× 5	7.7 [1.73]	9.8 [2.20]
	× 10	5.7 [1.28]	
	× 15	3.7 [0.83]	
	× 20	5.7 [1.28]	
	× 25	4.7 [1.06]	
16	× 5	11.1 [2.50]	14.1 [3.17]
	× 10	8.2 [1.84]	
	× 15	5.3 [1.19]	
	× 20	8.2 [1.84]	
	× 25	6.7 [1.51]	
20	× 5	11.6 [2.61]	13.8 [3.10]
	× 10	9.5 [2.14]	
	× 15	7.3 [1.64]	
	× 20	9.5 [2.14]	
	× 25	8.4 [1.89]	

Bore size mm	Stroke mm	N [lbf.]	
		Zero stroke	End of stroke
25	× 5	18.1 [4.07]	21.8 [4.90]
	× 10	14.5 [3.26]	
	× 15	10.7 [2.41]	
	× 20	14.5 [3.26]	
	× 25	12.7 [2.85]	
32	× 5	32.0 [7.19]	37.4 [8.41]
	× 10	26.7 [6.00]	
	× 15	21.3 [4.79]	
	× 20	26.7 [6.00]	
	× 25	24.0 [5.40]	
40	× 5	37.7 [8.47]	45.3 [10.18]
	× 10	30.2 [6.79]	
	× 15	22.6 [5.08]	
	× 20	30.2 [6.79]	
	× 25	26.4 [5.93]	
50	× 5	45.4 [10.21]	55.3 [12.43]
	× 10	40.5 [9.10]	
	× 15	35.5 [7.98]	
	× 20	43.0 [9.67]	
	× 25	38.0 [8.54]	

● **How to read the thrust table**

- For the thrust of the double rod cylinder double acting type, see the pull side of the double acting type thrust table. For the thrust of the single acting type, see the single acting pull type thrust table.
  - The thrust of the tandem cylinder is double that of the standard type when air is supplied simultaneously to Port A and Port B, for any operation type before the stroke in Cylinder 1 is complete. When air is supplied to any of Ports A, B, or C alone, then the thrust is the same as for the standard type.
  - The thrust for dual stroke cylinders is the same as for the standard type, for any operation type.
  - When directly carrying a load, care must be exercised of a lateral load.
- For details, see p.206 "Lateral Load."

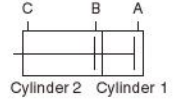

● **Square rod cylinders**

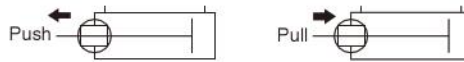

Bore size mm [in.]	Piston rod size mm [in.]	Operation	Pressure area mm <sup>2</sup> [in. <sup>2</sup> ]	Air pressure MPa									
				0.1 [15]	0.2 [29]	0.3 [44]	0.4 [58]	0.5 [73]	0.6 [87]	0.7 [102]	0.8 [116]	0.9 [131]	1.0 [145]
20 [0.787]	□ 7.4 [□ 0.291]	Push side	314.0 [0.487]	31.4 [7.06]	62.8 [14.1]	94.2 [21.2]	125.6 [28.23]	157.0 [35.29]	188.4 [42.35]	219.8 [49.41]	251.2 [56.47]	282.6 [63.53]	314.0 [70.59]
		Pull side	259.2 [0.402]	25.9 [5.82]	51.8 [11.6]	77.8 [17.5]	103.7 [23.3]	129.6 [29.13]	155.5 [34.96]	181.5 [40.80]	207.4 [46.62]	233.3 [52.45]	259.2 [58.27]
25 [0.984]	□ 7.4 [□ 0.291]	Push side	490.6 [0.760]	49.1 [11.0]	98.1 [22.1]	147.2 [33.09]	196.3 [44.13]	245.3 [55.14]	294.4 [66.18]	343.4 [77.20]	392.5 [88.23]	441.6 [99.27]	490.6 [110.3]
		Pull side	435.9 [0.676]	43.6 [9.80]	87.2 [19.6]	130.8 [29.40]	174.3 [39.18]	217.9 [48.98]	261.5 [58.79]	305.1 [68.59]	348.7 [78.39]	392.3 [88.19]	435.9 [97.99]
32 [1.260]	□ 13 [□ 0.512]	Push side	803.8 [1.246]	80.4 [18.1]	160.8 [36.15]	241.2 [54.22]	321.5 [72.27]	401.9 [90.35]	482.3 [108.4]	562.7 [126.5]	643.1 [144.6]	723.5 [162.6]	803.8 [180.7]
		Pull side	634.8 [0.984]	63.5 [14.3]	127.0 [28.55]	190.5 [42.82]	253.9 [57.08]	317.4 [71.35]	380.9 [85.63]	444.4 [99.90]	507.9 [114.2]	571.4 [128.5]	634.8 [142.7]
40 [1.575]	□ 13 [□ 0.512]	Push side	1256.0 [1.947]	125.6 [28.23]	251.2 [56.47]	376.8 [84.70]	502.4 [112.9]	628.0 [141.2]	753.6 [169.4]	879.2 [197.6]	1004.8 [225.9]	1130.4 [254.1]	1256.0 [282.3]
		Pull side	1087.0 [1.685]	108.7 [24.44]	217.4 [48.87]	326.1 [73.31]	434.8 [97.74]	543.5 [122.2]	652.2 [146.6]	760.9 [171.1]	869.6 [195.5]	978.3 [219.9]	1087.0 [244.4]
50 [1.969]	□ 18 [□ 0.709]	Push side	1962.5 [3.042]	196.3 [44.13]	392.5 [88.23]	588.8 [132.4]	785.0 [176.5]	981.3 [220.6]	1177.5 [264.7]	1373.8 [308.8]	1570.0 [352.9]	1766.3 [397.1]	1962.5 [441.2]
		Pull side	1638.5 [2.540]	163.9 [36.84]	327.7 [73.67]	491.6 [110.5]	655.4 [147.3]	819.3 [184.2]	983.1 [221.0]	1147.0 [257.8]	1310.8 [294.7]	1474.7 [331.5]	1638.5 [368.3]
63 [2.480]	□ 18 [□ 0.709]	Push side	3115.7 [4.829]	311.6 [70.05]	623.1 [140.1]	934.7 [210.1]	1246.3 [280.2]	1557.8 [350.2]	1869.4 [420.2]	2181.0 [490.3]	2492.5 [560.3]	2804.1 [630.4]	3115.7 [700.4]
		Pull side	2791.7 [4.327]	279.2 [62.76]	558.3 [125.5]	837.5 [188.3]	1116.7 [251.0]	1395.8 [313.8]	1675.0 [376.5]	1954.2 [439.3]	2233.3 [502.0]	2512.5 [564.8]	2791.7 [627.6]

# JIG CYLINDERS C SERIES SQUARE ROD CYLINDERS

## Double Acting Type

### Symbol

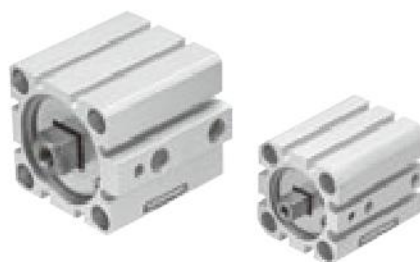
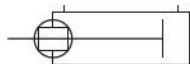

### Specifications

Item	Bore size mm [in.]	20 [0.787]	25 [0.984]	32 [1.260]	40 [1.575]	50 [1.969]	63 [2.480]
Operation type		Double acting type					
Media		Air					
Operating pressure range	MPa [psi.]	0.1~1.0 [15~145]					
Proof pressure	MPa [psi.]	1.5 [218]					
Operating temperature range	°C [°F]	0~60 [32~140]					
Operating speed range	mm/s [in./sec.]	30~500 [1.2~19.7]				30~300 [1.2~11.8]	
Cushion		Rubber bumper (Optional)					
Lubrication		Not required (If lubrication is required, use Turbine Oil Class 1 [ISO VG32] or equivalent.)					
Non-rotating accuracy		±1.5°		±0.8°		±0.6°	
Allowable torque <sup>Note</sup>	N·cm [in·lbf]	2 [0.18]	2.4 [0.21]		4.4 [0.39]		
Port size		M5×0.8		Rc1/8		Rc1/4	

Remark: For Handling Instructions and Precautions, see p.205.

Note: Maximum torque allowed on piston rod.

### Bore Size and Stroke

For non-standard strokes, see p.206.

Bore size	Standard strokes	
	Standard cylinder	Cylinder with magnet
20	5, 10, 15, 20, 25, 30, 35, 40, 45, 50	5, 10, 15, 20, 25, 30, 35, 40, 45, 50
25		
32	5, 10, 15, 20, 25, 30, 35, 40, 45, 50, 75, 100	5, 10, 15, 20, 25, 30, 35, 40, 45, 50, 75, 100
40		
50	10, 15, 20, 25, 30, 35, 40, 45, 50, 75, 100	10, 15, 20, 25, 30, 35, 40, 45, 50, 75, 100
63		

Remarks: 1. Stroke tolerance  ${}^+1_0 [{}^{+0.039}in.]$

2. In most cases, body cutting is used for the non-standard strokes.

However, body cutting is not used for strokes of less than 5mm for  $\phi 12 \sim \phi 40$ , and strokes of less than 10mm for  $\phi 50$  and  $\phi 63$ . The collar packed is used for these cases.

# Order Codes for Square Rod Cylinders

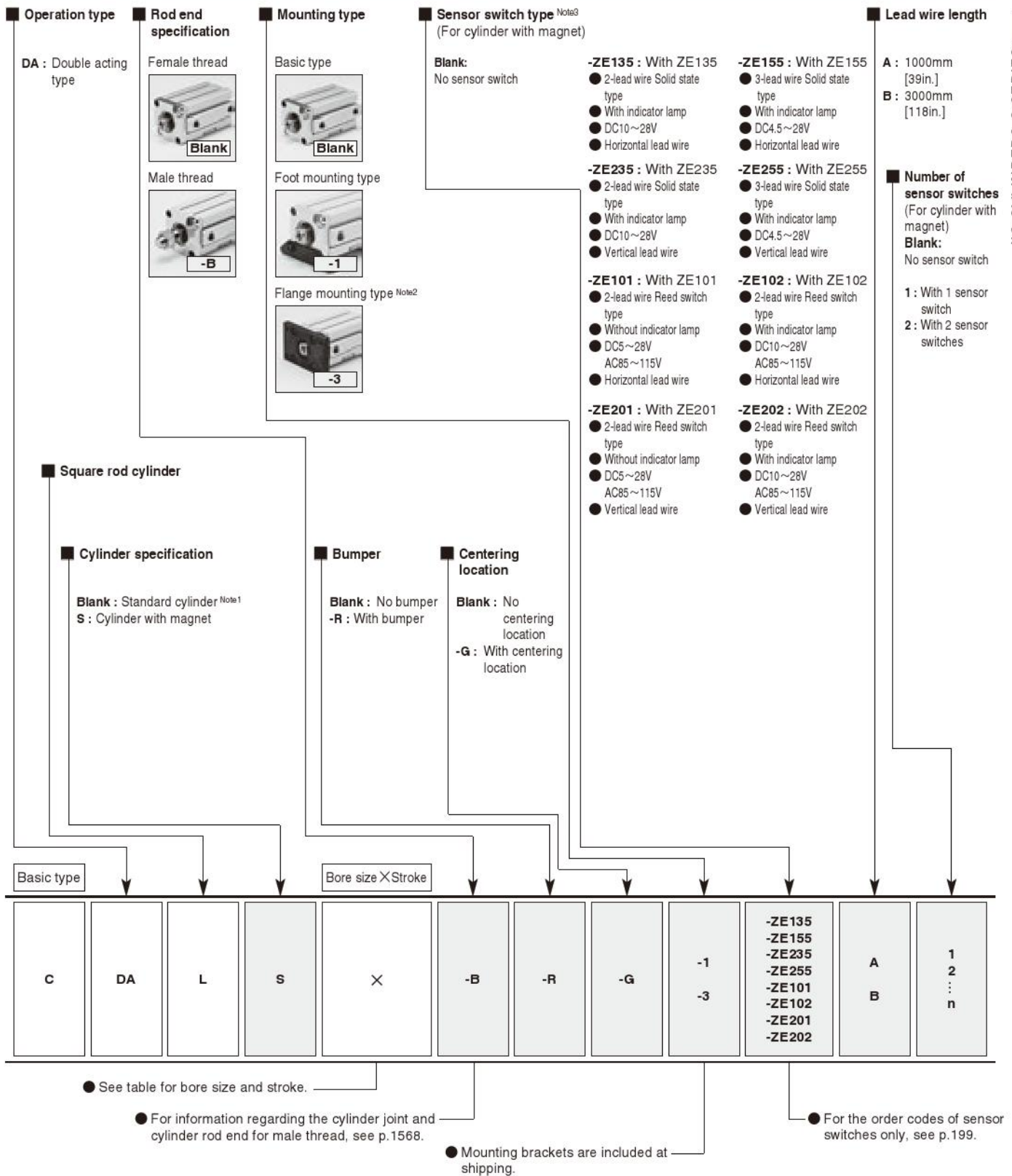

Notes: 1. In the standard cylinder, a magnet for the sensor switch is not built-in.  
 2. When using with a centering location (-G), the flange mounting bracket can be mounted on the head side only.  
 3. For details of sensor switches, see p.1544.

## Additional Parts (To be ordered separately)

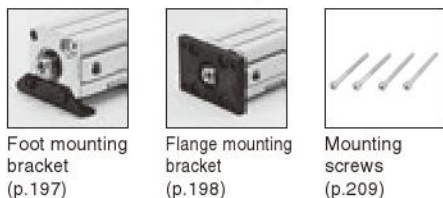

# Inner Construction and Major Parts

## ● Double acting type

●  $\phi 20 \sim \phi 40$

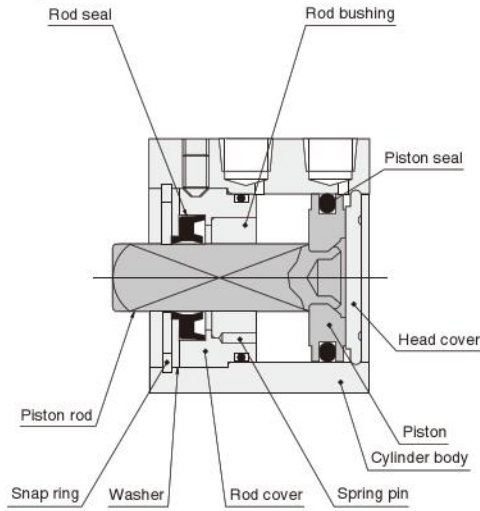

●  $\phi 50, \phi 63$

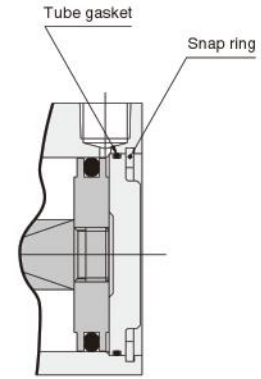

## ● Cylinder with magnet

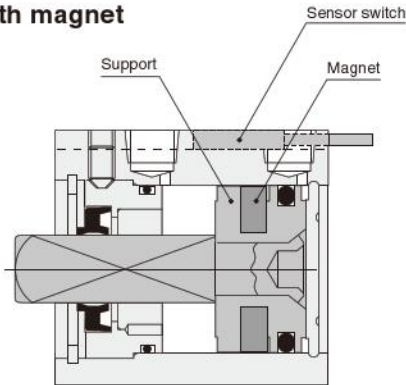

## ● With bumper

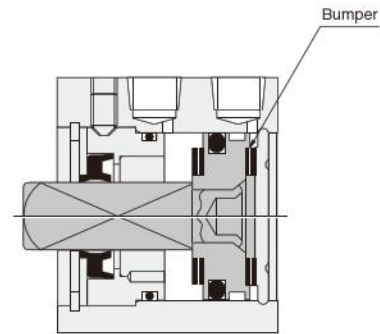

## Major Parts and Materials

Parts	Bore mm	$\phi 20 \sim \phi 63$
Cylinder body		Aluminum alloy (anodized)
Piston		Aluminum alloy (special rust prevention treatment)
Piston rod		Steel (chrome plated)
Seal		Synthetic rubber (NBR; urethane for the rod seal)
Rod bushing		Oil impregnated bronze
Rod cover		Aluminum alloy (anodized)
Head cover		Aluminum alloy (anodized)
Spring pin		Steel
Washer		Steel (nickel plated)
Snap ring		Steel (phosphate coating)
Bumper		Synthetic rubber (NBR)
Magnet		Plastic magnet
Support		Aluminum alloy (special rust prevention treatment)

## Seals

Parts Bore mm	Rod seal	Piston seal	Tube gasket	
			Rod side	Head side
$\phi 20$	KC-7.4	COP-20	Y090216	None
$\phi 25$	KC-7.4	COP-25	Y090210	None
$\phi 32$	KC-13	COP-32	L090084	None
$\phi 40$	KC-13	COP-40	L090151	None
$\phi 50$	KC-18	COP-50	L090174	L090106
$\phi 63$	KC-18	COP-63	L090180	L090107

## Mass

Bore size mm [in.]	Zero stroke mass <sup>Note1</sup>	Additional mass for each 1mm [0.0394in.] stroke	Additional mass of cylinder with bumper	Additional mass of cylinder with magnet	Mass of mounting bracket		Additional mass of sensor switch <sup>Note2</sup>	
					Foot bracket	Flange bracket	ZE□□□A	ZE□□□B
<b>20 [0.787]</b>	63.89 [2.254]	2.07 [0.0730]	10.36 [0.365]	25.71 [0.907]	87 [3.07]	105 [3.70]	15 [0.53]	35 [1.23]
<b>25 [0.984]</b>	96.54 [3.405]	2.65 [0.0935]	13.24 [0.467]	37.47 [1.322]	108 [3.81]	165 [5.82]		
<b>32 [1.260]</b>	160.05 [5.646]	3.86 [0.136]	19.31 [0.681]	52.43 [1.849]	131 [4.62]	196 [6.91]		
<b>40 [1.575]</b>	241.47 [8.517]	4.52 [0.159]	0	69.15 [2.439]	168 [5.93]	351 [12.38]		
<b>50 [1.969]</b>	477.70 [16.850]	7.11 [0.251]	0	108 [3.81]	232 [8.18]	471 [16.61]		
<b>63 [2.480]</b>	706.58 [24.923]	8.77 [0.309]	0	159 [5.61]	312 [11.01]	615 [21.69]		

Notes: 1. The above table is for the standard strokes.

2. Sensor switch codes A and B show the lead wire lengths.

A : 1000mm [39in.] B : 3000mm [118in.]

Calculation example: For the mass of a double acting type cylinder with magnet, bore size of 32mm, stroke of 30mm, and with 2 sensor switches (ZE135A)  
 $167.38 + (3.86 \times 30) + 52.43 + (15 \times 2) = 365.61\text{g}$  [12.896oz.]

# Dimensions of Square Rod Cylinder Double Acting Type (mm)

●  $\phi 20 \sim \phi 25$

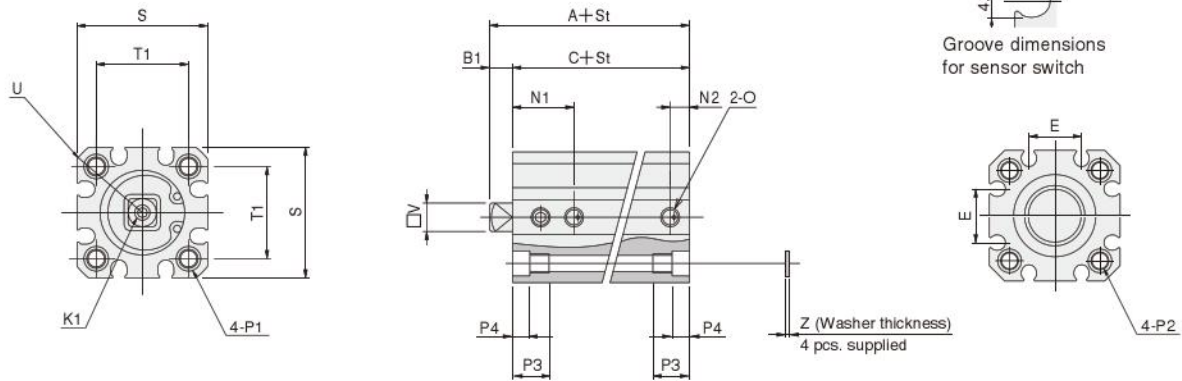

●  $\phi 32 \sim \phi 63$

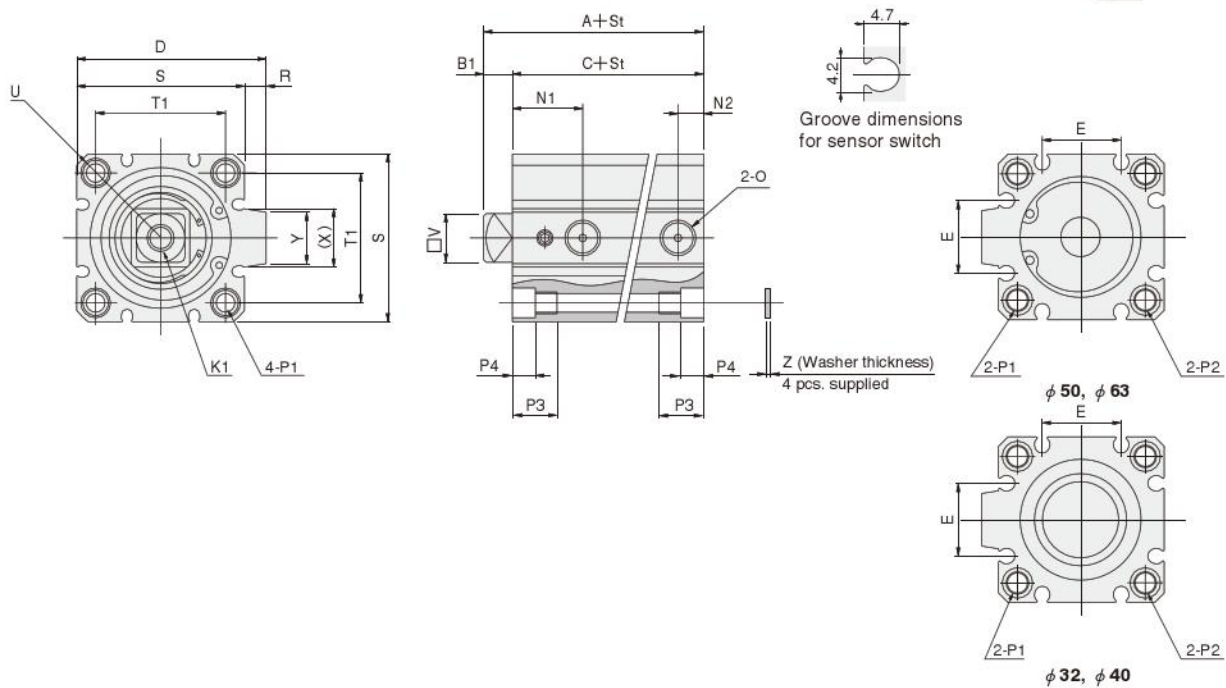

Type Code	Standard cylinder (CDAL)			Cylinder with magnet (CDALS)			Standard cylinder with bumper (CDAL-R)			Cylinder with magnet and bumper (CDALS-R)			D	E	K <sub>1</sub>	N <sub>1</sub>	N <sub>2</sub>	O
	A	B <sub>1</sub>	C	A	B <sub>1</sub>	C	A	B <sub>1</sub>	C	A	B <sub>1</sub>	C						
20 [0.787]	32	6	26	42	6	36	37	6	31	47	6	41	—	12.2	M4X0.7 Depth6	16	5	M5X0.8
25 [0.984]	33.5	6	27.5	43.5	6	37.5	38.5	6	32.5	48.5	6	42.5	—	12.2	M4X0.7 Depth6	17	5	M5X0.8
32 [1.260]	39	7	32	49	7	42	44	7	37	49	7	42	48.5	18.2	M8X1.25 Depth12	18.5	7.5(6)	Rc1/8
40 [1.575]	43	7	36	53	7	46	43	7	36	53	7	46	56.5	18.2	M8X1.25 Depth12	20.5	7.5	Rc1/8
50 [1.969]	53.7	10.7	43	63.7	10.7	53	53.7	10.7	43	63.7	10.7	53	70	24.8	M10X1.5 Depth15	26	9.5	Rc1/4
63 [2.480]	56.2	9.2	47	66.2	9.2	57	56.2	9.2	47	66.2	9.2	57	83	26.8	M10X1.5 Depth15	27.5	11	Rc1/4

Code	P <sub>1</sub>			P <sub>2</sub>			P <sub>3</sub>	P <sub>4</sub>	R	S	T <sub>1</sub>	U	V	X	Y	Z	Appropriate through bolt※
20 [0.787]	$\phi 4.3$ (Thru hole)	C'bore $\phi 6.5$ (Both sides)	and M5X0.8 (Both sides)	Counterbore $\phi 6.5$	and M5X0.8		9.5	4.5	—	34	24	R22	7.4	—	—	1	M3
25 [0.984]	$\phi 5.1$ (Thru hole)	C'bore $\phi 8$ (Both sides)	and M6X1 (Both sides)	Counterbore $\phi 8$	and M6X1		11.5	5.5	—	40	28	R25	7.4	—	—	1	M4
32 [1.260]	$\phi 5.1$ (Thru hole)	C'bore $\phi 8$ (Both sides)	and M6X1 (Both sides)	Counterbore $\phi 8$	and M6X1		11.5	5.5	4.5	44	34	R29.5	13	15	13.6	1	M4
40 [1.575]	$\phi 6.9$ (Thru hole)	C'bore $\phi 9.5$ (Both sides)	and M8X1.25 (Both sides)	Counterbore $\phi 9.5$	and M8X1.25		15.5	7.5	4.5	52	40	R35	13	15	13.6	1.6	M5
50 [1.969]	$\phi 6.9$ (Thru hole)	C'bore $\phi 11$ (Both sides)	and M8X1.25 (Both sides)	Counterbore $\phi 11$	and M8X1.25		16.5	8.5	8	62	48	R41	18	21.6	19	1.6	M6
63 [2.480]	$\phi 6.9$ (Thru hole)	C'bore $\phi 11$ (Both sides)	and M8X1.25 (Both sides)	Counterbore $\phi 11$	and M8X1.25		16.5	8.5	8	75	60	R50	18	21.6	19	1.6	M6

Note: Figure in parentheses [ ] is for the standard cylinder (CDAL) with 5mm stroke.  
 ※ Some types of mounting screws are available (to be ordered separately). See p.209.

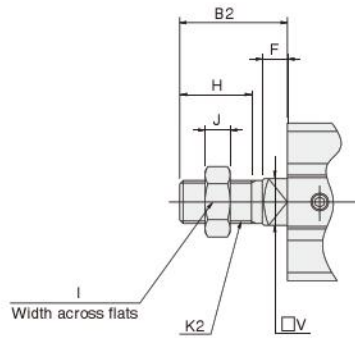

Bore mm (in.)	Code	B <sub>2</sub>	F	H	I	J	K <sub>2</sub>	V
20	[0.787]	21	6	13	10	5	M6×1	7.4
25	[0.984]	23	6	15	12	5	M8×1	7.4
32	[1.260]	30	7	20	17	7	M12×1.25	13
40	[1.575]	35	7	25	19	8	M14×1.5	13
50	[1.969]	38.7	10.7	25	27	11	M18×1.5	18
63	[2.480]	37.2	9.2	25	27	11	M18×1.5	18

Remark: Cylinder joints and cylinder rod ends are available for mounting with the rod end male thread specification. For details, see p.1568.

Dimensions of Centering Location (mm)

● Female thread specification, with centering location

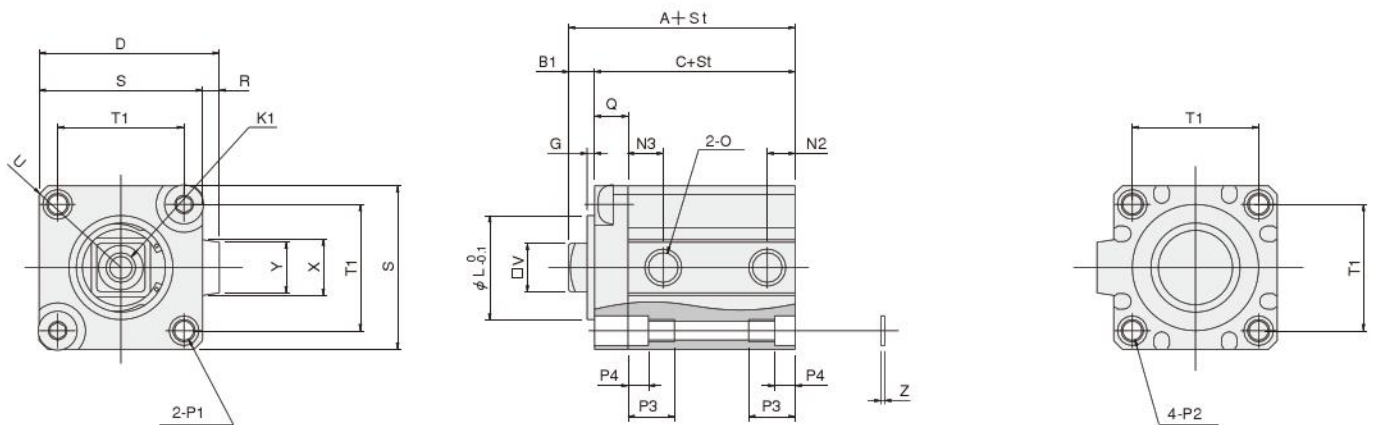

● Male thread specification, with centering location

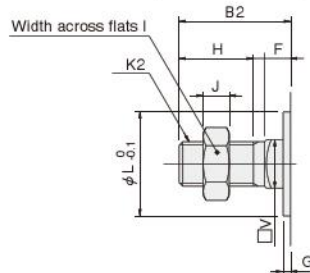

Bore mm (in.)	Code	B <sub>1</sub>	G	L	N <sub>3</sub>	Q
20	[0.787]	6	1.5	18	9.5	6.5
25	[0.984]	6	2	18	10.5	6.5
32	[1.260]	7	2	28	9.5	9
40	[1.575]	7	2	28	10.5	10
50	[1.969]	10.7	2	38	11	15
63	[2.480]	9.2	2	40	12.5	15

● The outward view of the square rod cylinder with centering location differs from the view in the case of no centering location, in that a rod cover is mounted on the piston rod side, as shown in the dimension above. For the dimension tables for female thread specification with centering location, also use the table on p.152, while for male thread specification with centering location, see the above this page.

# JIG CYLINDERS C SERIES MOUNTING BRACKETS

Foot Mounting Bracket, Flange Mounting Bracket, Clevis Mounting Bracket



## Order Codes of Mounting Bracket Only

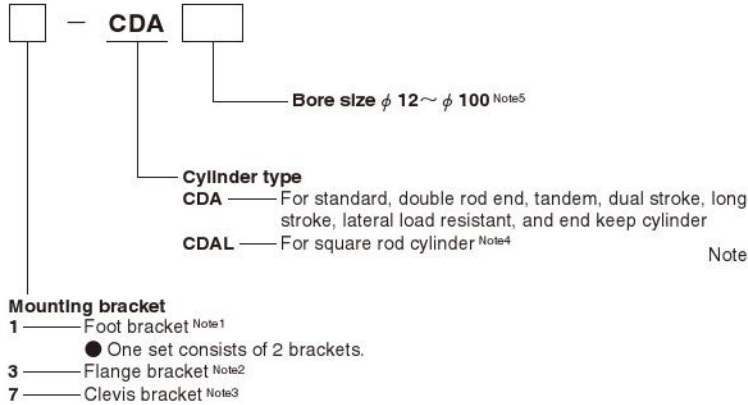

- Notes: 1. Cannot be mounted on tandem or dual stroke cylinders. And cannot be mounted on the 5mm strokes of  $\phi 16$  and  $\phi 25$ , and 10mm strokes of  $\phi 50$ ,  $\phi 63$ , and  $\phi 80$  of the standard cylinders.  
 2. Cannot be mounted on the head side of the tandem cylinder, cylinder 1 side of the dual stroke cylinder, the rod side of the square rod cylinder with centering location, or the bore size  $\phi 40$  with centering location (-G).  
 3. Cannot be used with anything other than the long stroke cylinder, the lateral load resistant cylinder, or the end keep cylinder.  
 4. Applicable to the foot mounting bracket only.  
 5. Not available for  $\phi 6$  [0.236in.],  $\phi 8$  [0.315in.], and  $\phi 10$  [0.394in.].

## Dimensions of Foot Mounting Bracket (mm)



$\phi 12 \sim \phi 40$  : CDA-OP1,  $\phi 50 \sim \phi 100$  : CDA-OP2

### ● $\phi 12 \sim \phi 16$

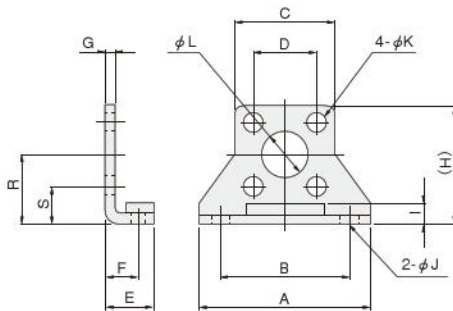

### ● $\phi 20 \sim \phi 100$

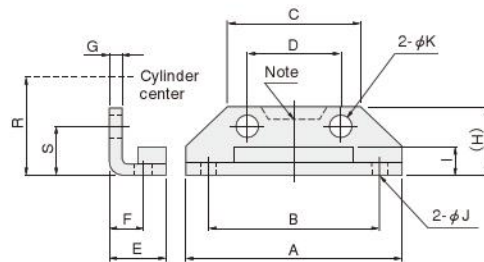

Note: Only for  $\phi 50$

### ● Mounting screw For $\phi 12 \sim \phi 80$

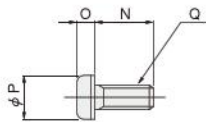

### For $\phi 100$

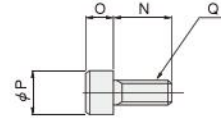

Bore mm [in.]	Code	Material: Steel																	Mass g [oz.]	
		A	B	C	D	E	F	G	H	I	J	K	L	N	O	P	Q	R		S
12 [0.472]		44	34	25	16.3	12.5	8	2	29.5	4.5	4.5	5.5	11	12	2.7	9.5	M5	17	8.9	50 [1.76]
16 [0.630]		48	38	29	19.8	13	8	2	33.5	4.5	4.5	5.5	11	12	2.7	9.5	M5	19	9.1	62 [2.19]
20 [0.787]		54	44	34	24	15	9.2	3.2	16.5	7	4.5	5.5	—	12 (12, 20)	2.7	9.5	M5	24	12	84 [2.96] (87 [3.07])
25 [0.984]		64	52	40	28	16.5	10.7	3.2	17.5	6	5.5	6.6	—	14 (14, 22)	3.3	10.5	M6	26	12	104 [3.67] (108 [3.81])
32 [1.260]		68	56	44	34	17	11.2	3.2	19	8	5.5	6.6	—	14 (14, 25)	3.3	10.5	M6	30	13	126 [4.44] (131 [4.62])
40 [1.575]		78	64	52	40	18.2	11.2	3.2	19	7	6.6	9	—	20 (20, 30)	4.4	14	M8	33	13	180 [5.64] (188 [5.93])
50 [1.969]		96	78	62	48	22.7	14.7	3.2	22	8	9	9	—	20 (20, 35)	4.4	14	M8	39	15	220 [7.76] (232 [8.18])
63 [2.480]		108	90	75	60	25.2	16.2	3.2	24	8.5	9	9	—	20 (20, 35)	4.4	14	M8	46	16	300 [10.58] (312 [11.01])
80 [3.150]		134	112	94	74	30.5	19.5	4.5	33	12	11	14	—	25	6.6	21	M12	59	22	644 [22.72]
100 [3.940]		160	134	114	90	35.5	23	6	40	14	14	16	—	30	14	21	M14	71	26	1172 [41.34]

Remark: Figures in parentheses ( ) are for square rod cylinders.  
 Two figures in parentheses ( ), Left side: for head side; Right side: for rod side

## Dimensions of Flange Mounting Bracket (mm)



φ 12~φ 40 : CDA-OP3, φ 50~φ 100 : CDA-OP4

### ● φ 12~φ 16

### ● Mounting screw For φ 12~φ 80

### ● φ 20~φ 100

### ● Mounting screw For φ 100

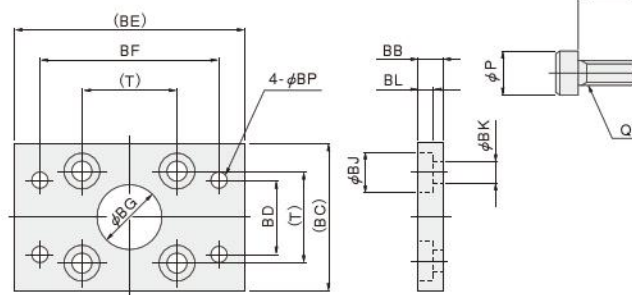
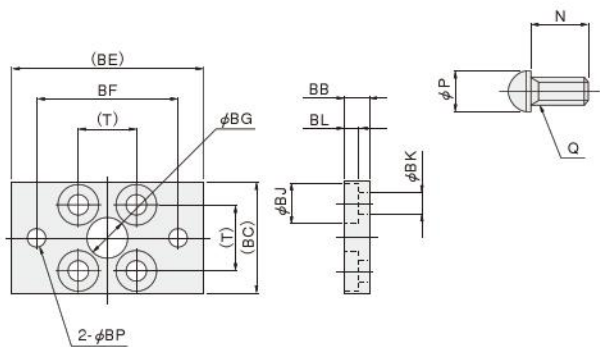

Material: Steel

Bore mm [in.]	Code	N	P	Q	T	BB	BC	BD	BE	BF	BG	BJ	BK	BL	BP	Mass g [oz.]
12 [0.472]	12	9.5	M5	16.3	6	28	—	—	50	38	11	10	5.5	3.6	4.5	55 [1.94]
16 [0.630]	12	9.5	M5	19.8	6	32	—	—	54	42	11	10	5.5	3.6	4.5	71 [2.50]
20 [0.787]	12(18)	9.5	M5	24	6	36	24	—	58	46	15	10	5.5	3.6	4.5	101 [3.56] (105 [3.70])
25 [0.984]	14(22)	10.5	M6	28	8	42	28	—	68	54	17	11	6.6	4.3	5.5	160 [5.64] (165 [5.82])
32 [1.260]	14(25)	10.5	M6	34	8	48	34	—	72	58	22	11	6.6	4.3	5.5	186 [6.56] (196 [6.91])
40 [1.575]	20(30)	14	M8	40	8	58	40	—	84	68	28	15	9	5.3	6.6	335 [11.82] (351 [12.38])
50 [1.969]	20(35)	14	M8	48	8	66	40	—	102	82	38	15	9	5.3	9	447 [15.77] (471 [16.61])
63 [2.480]	20(35)	14	M8	60	8	78	50	—	116	96	40	15	9	5.3	9	591 [20.85] (615 [21.69])
80 [3.150]	25	21	M12	74	12	100	70	—	142	118	45	22	14	7.3	11	1414 [49.88]
100 [3.940]	30	21	M14	90	20	116	80	—	170	142	55	23	16	15.2	14	2606 [91.92]

Remark: Figures in parentheses ( ) are for square rod cylinders.

## Dimensions of Clevis Mounting Bracket (mm)



φ 12~φ 40 : CDA-OP5, φ 50~φ 100 : CDA-OP6

### ● φ 12~φ 40

### ● φ 50~φ 100

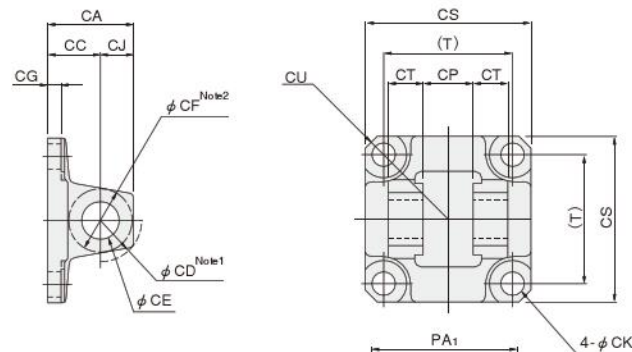
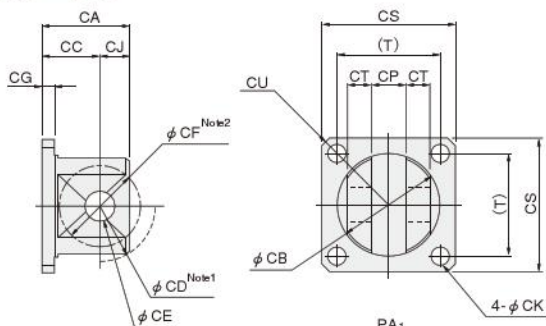

### ● Mounting screw For φ 12~φ 100

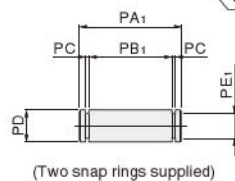
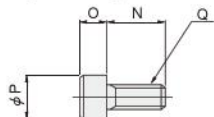

(Two snap rings supplied)

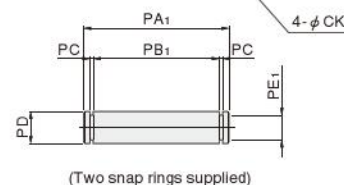

(Two snap rings supplied)

Material: Steel

Bore mm [in.]	Code	N	O	P	Q	T	CA	CB	CC	CD	CE	CF	CG	CJ	CK	CP	CS	CT	CU	PA <sub>1</sub>	PB <sub>1</sub>	PC	PD	PE <sub>1</sub>	Mass g [oz.]
12 [0.472]	12	5	8.5	M5	16.3	15	12	11	R 7.5	4 <sup>+0.03</sup> <sub>0</sub>	R5	4	4	5.5	4 <sup>+0.2</sup> <sub>+0.1</sub>	25	3	R16	15	10.6	0.7	4 <sub>8</sub>	2.5	30 [1.06]	
16 [0.630]	12	5	8.5	M5	19.8	17	16	12	R10	5 <sup>+0.03</sup> <sub>0</sub>	R6	4	5	5.5	5 <sup>+0.2</sup> <sub>+0.1</sub>	29	3.5	R19	17	12.6	0.7	5 <sub>8</sub>	3	40 [1.41]	
20 [0.787]	12	5	8.5	M5	24	25	22	17	R14	8 <sup>+0.04</sup> <sub>0</sub>	R11	4	8	5.5	8 <sup>+0.4</sup> <sub>+0.2</sub>	34	5.2	R22	24.4	19.6	0.9	8 <sub>8</sub>	6	75 [2.65]	
25 [0.984]	16	6	10	M6	28	25	26	17	R16	8 <sup>+0.04</sup> <sub>0</sub>	R11	4	8	6.6	8 <sup>+0.4</sup> <sub>+0.2</sub>	40	5.2	R25	24.4	19.6	0.9	8 <sub>8</sub>	6	100 [3.53]	
32 [1.260]	16	6	10	M6	34	29	34	19	R20	10 <sup>+0.04</sup> <sub>0</sub>	R12.5	4	10	6.6	12 <sup>+0.4</sup> <sub>+0.2</sub>	44	8	R29.5	34	29.2	0.9	10 <sub>8</sub>	8	165 [5.82]	
40 [1.575]	20	8	13	M8	40	29	34	19	R20	10 <sup>+0.04</sup> <sub>0</sub>	R12.5	4	10	9	12 <sup>+0.4</sup> <sub>+0.2</sub>	52	8	R35	34	29.2	0.9	10 <sub>8</sub>	8	200 [7.05]	
50 [1.969]	22	8	13	M8	48	32	—	19	R17	14 <sup>+0.08</sup> <sub>0</sub>	R14	5	13	9 Counterbore φ 17	20 <sup>+0.6</sup> <sub>+0.3</sub>	63	12.5	R41.5	55	47	1.15	14 <sup>-0.030</sup> <sub>-0.070</sub>	13.4	315 [11.11]	
63 [2.480]	20	8	13	M8	60	32	—	19	R17	14 <sup>+0.08</sup> <sub>0</sub>	R14	6	13	9 Counterbore φ 20	20 <sup>+0.6</sup> <sub>+0.3</sub>	76	15	R50.5	60	52	1.15	14 <sup>-0.030</sup> <sub>-0.070</sub>	13.4	485 [17.46]	
80 [3.150]	30	12	18	M12	74	52	—	32	R24	20 <sup>+0.1</sup> <sub>0</sub>	R20	7	20	14 Counterbore φ 22	32 <sup>+0.6</sup> <sub>+0.3</sub>	95	16	R62.5	74	66	1.35	20 <sup>-0.040</sup> <sub>-0.084</sub>	19	1110 [39.15]	
100 [3.940]	30	14	21	M14	90	52	—	32	R24	20 <sup>+0.1</sup> <sub>0</sub>	R21	7	20	16 Counterbore φ 26	32 <sup>+0.6</sup> <sub>+0.3</sub>	115	16	R75.5	74	66	1.35	20 <sup>-0.040</sup> <sub>-0.084</sub>	19	1490 [52.56]	

Notes: 1. CD = Swing range of clevis mounting bracket itself.

2. CF = Maximum radius of swing for mating bracket.

Remark: φ 12~φ 50 are mounted with 2 bolts.

# JIG CYLINDERS C SERIES SENSOR SWITCHES

Solid State Type, Reed Switch Type



## Order Codes

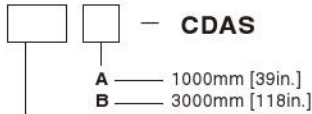

<b>ZE135</b>	Solid state type	with indicator lamp	DC10V~28V	Horizontal lead wire
<b>ZE235</b>	Solid state type	with indicator lamp	DC10V~28V	Vertical lead wire
<b>ZE101</b>	Reed switch type	without indicator lamp	DC5V~28V	Horizontal lead wire
			AC85~115V	
<b>ZE201</b>	Reed switch type	without indicator lamp	DC5V~28V	Vertical lead wire
			AC85~115V	
<b>ZE155</b>	Solid state type	with indicator lamp	DC4.5V~28V	Horizontal lead wire
<b>ZE255</b>	Solid state type	with indicator lamp	DC4.5V~28V	Vertical lead wire
<b>ZE102</b>	Reed switch type	with indicator lamp	DC10V~28V	Horizontal lead wire
			AC85~115V	
<b>ZE202</b>	Reed switch type	with indicator lamp	DC10V~28V	Vertical lead wire
			AC85~115V	

● For details of sensor switches, see p.1544.

## Moving Sensor Switch

- Loosening mounting screw allows the sensor switch to be moved along the switch mounting groove on the cylinder body.
- Tighten the mounting screw with a tightening torque of 0.1~0.2N·m [0.9~1.8in·lbf].

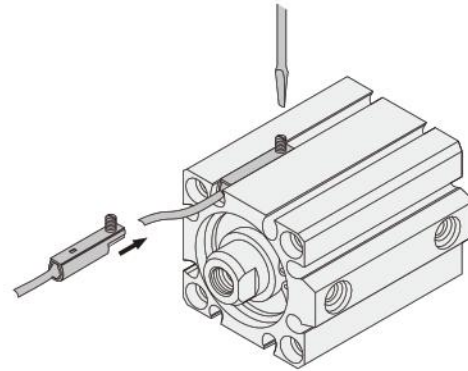

## Minimum Cylinder Strokes When Using Sensor Switches

### ● Solid state type

Bore size	2 pcs. mounting <sup>Note</sup>		1 pc. mounting
	1-surface mounting	2-surface mounting	
6~12 [0.236~0.472in.]	30	10	5
16~100 [0.630~3.940in.]	10		

Note: Two pieces can be mounted with 5mm stroke.  
Take note that overlapping may occur, however.

### ● Reed switch type

Bore size	2 pcs. mounting		1 pc. mounting
	1-surface mounting	2-surface mounting	
12 [0.472in.]	30	10	10
16~100 [0.630~3.940in.]	10		

## Sensor Switch Operating Range, Response Differential, and Maximum Sensing Location

### ● Operating range : $\ell$

The distance the piston travels in one direction, while the switch is in the ON position.

### ● Response differential : C

The distance between the point where the piston turns the switch ON and the point where the switch is turned OFF as the piston travels in the opposite direction.

### ● Solid state type

Item	Bore	6 [0.236]	8 [0.315]	10 [0.394]	12 [0.472]	16 [0.630]	20 [0.787]	25 [0.984]	32 [1.260]	40 [1.575]	50 [1.969]	63 [2.480]	80 [3.150]	100 [3.940]
Operating range : $\ell$		1.8~3.0 [0.071~0.118]	1.8~3.0 [0.071~0.118]	2.0~3.2 [0.079~0.126]	2~4 [0.079~0.157]	2~5 [0.079~0.197]	3.5~7.5 [0.138~0.295]	4~8 [0.157~0.315]	3~7 [0.118~0.276]	3.5~7.5 [0.138~0.295]	3.5~7.5 [0.138~0.295]	4~8.5 [0.157~0.335]	4.5~9.5 [0.177~0.374]	4.5~9.0 [0.177~0.354]
Response differential : C		0.2 [0.008] or less				0.5 [0.02] or less								
Maximum sensing location		6 [0.236]												

Remark: The above table shows reference values.

### ● Reed switch type

Item	Bore	12 [0.472]	16 [0.630]	20 [0.787]	25 [0.984]	32 [1.260]	40 [1.575]	50 [1.969]	63 [2.480]	80 [3.150]	100 [3.940]
Operating range : $\ell$		4.5~8.5 [0.177~0.335]	5.5~9.5 [0.217~0.374]	9~13.5 [0.354~0.531]	10~15.5 [0.394~0.610]	8~12 [0.315~0.472]	8.5~14 [0.335~0.551]	9~15 [0.354~0.591]	10~16 [0.394~0.630]	11~16 [0.433~0.630]	11~16.5 [0.433~0.650]
Response differential : C		1.0 [0.039] or less	2.0 [0.079] or less				3.0 [0.118] or less		2.5 [0.098] or less		
Maximum sensing location		10 [0.394]									

Remark: The above table shows reference values.

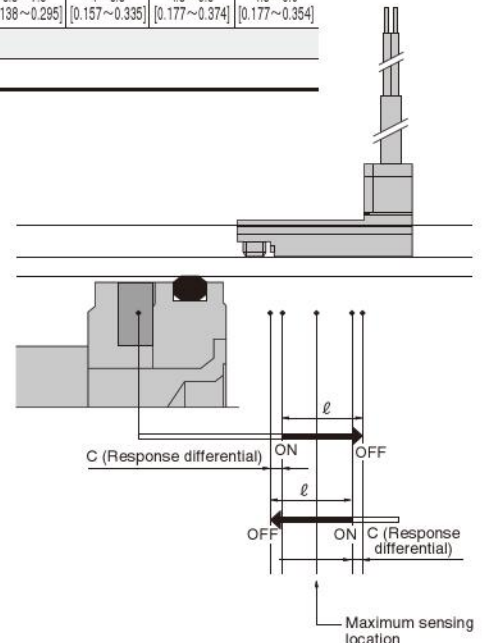

# Mounting Sensor Switch

●  $\phi 6 \sim \phi 12$

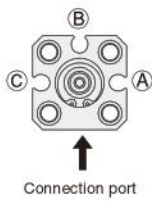

●  $\phi 16$

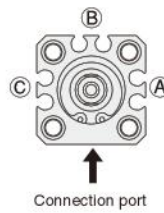

●  $\phi 20 \sim \phi 100$

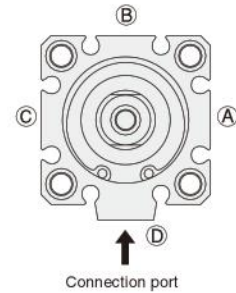

● The drawing is for  $\phi 32$ .

The standard mounting positions at shipping for the end of stroke detection on the rod side is either surface A or surface C, while the end of stroke detection on the head side is surface B. If mounting sensor switches on the same surface for detection of both ends is required, consult us. (The sensor switch may sometimes protrude from the cylinder body.)

Mounting on any of surfaces A, B, or C allows detection of the end of stroke on the rod side and head side. (The sensor switch may sometimes protrude from the cylinder body.)

Mounting on any of surfaces A, B, C, or D allows detection of the end of stroke on the rod side and head side. (The sensor switch may sometimes protrude from the cylinder body.) However, the ZE2□ sensor switches cannot be mounted on the D position in  $\phi 32$ ,  $\phi 40$ , and  $\phi 50$ .

## Mounting Location of End of Stroke Detection Sensor Switch

When the sensor switch is mounted in the position shown in the diagram below (figures in the tables are reference values), the magnet reaches the sensor switch's maximum sensing location at the end of the stroke.

● Standard cylinder,  
Non-rotating cylinder

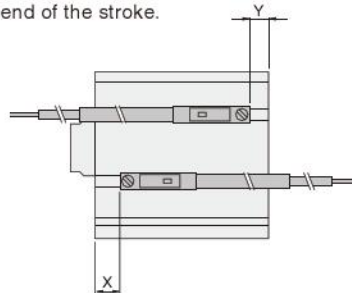

■ Solid state type

● Double acting type

mm [in.]

Code \ Bore		6	8	10	12	16	20	25	32	40	50	63	80	100
X	Standard type	7.2 [0.283]	8 [0.315]	8.3 [0.327]	7 [0.276]	7 [0.276]	11 [0.433]	11 [0.433]	13.5 [0.531]	14.5 [0.571]	12.5 [0.492]	15 [0.591]	20 [0.787]	25 [0.984]
	With bumper (-R)	—	—	—	10 [0.394]	10 [0.394]	15 [0.591]	16 [0.630]	15.5 [0.610]	16.5 [0.650]	15.5 [0.610]	15 [0.591]	20 [0.787]	25 [0.984]
Y	Standard type	1 [0.039]	0.3 [0.012]	1 [0.039]	4 [0.157]	4 [0.157]	7.5 [0.295]	9 [0.354]	8.5 [0.335]	10.5 [0.413]	14.5 [0.571]	16 [0.630]	20 [0.787]	25 [0.984]
	With bumper (-R)	—	—	—	6 [0.236]	6 [0.236]	8.5 [0.335]	9 [0.354]	6.5 [0.256]	8.5 [0.335]	11.5 [0.453]	16 [0.630]	20 [0.787]	25 [0.984]

■ Reed switch type

● Double acting type

mm [in.]

Code \ Bore		12	16	20	25	32	40	50	63	80	100
X	Standard type	2.5 [0.098]	2.5 [0.098]	6.5 [0.256]	6.5 [0.256]	9 [0.354]	10 [0.394]	8 [0.315]	10.5 [0.413]	15.5 [0.610]	20.5 [0.807]
	With bumper (-R)	5.5 [0.217]	5.5 [0.217]	10.5 [0.413]	11.5 [0.453]	11 [0.433]	12 [0.472]	11 [0.433]	10.5 [0.413]	15.5 [0.610]	20.5 [0.807]
Y	Standard type	-0.5 [-0.020]	-0.5 [-0.020]	3 [0.118]	4.5 [0.177]	4 [0.157]	6 [0.236]	10 [0.394]	11.5 [0.453]	15.5 [0.610]	20.5 [0.807]
	With bumper (-R)	1.5 [0.059]	1.5 [0.059]	4 [0.157]	4.5 [0.177]	2 [0.079]	4 [0.157]	7 [0.276]	11.5 [0.453]	15.5 [0.610]	20.5 [0.807]

● Single acting push type

mm [in.]

Code \ Bore		6	8	10	12	16	20	25	32	40	50
X	Standard type	17.2 [0.677]	18 [0.709]	18.3 [0.720]	15 [0.591]	15 [0.591]	14 [0.551]	14.5 [0.571]	15.5 [0.610]	17.5 [0.689]	17 [0.669]
	Y	1 [0.039]	0.3 [0.012]	1 [0.039]	1 [0.039]	1 [0.039]	4.5 [0.177]	5.5 [0.217]	6.5 [0.256]	7.5 [0.295]	10.5 [0.413]

● Single acting push type

mm [in.]

Code \ Bore		12	16	20	25	32	40	50
X	Standard type	10.5 [0.413]	10.5 [0.413]	9.5 [0.374]	10 [0.394]	11 [0.433]	13 [0.512]	12.5 [0.492]
	Y	-3.5 [-0.138]	-3.5 [-0.138]	0 [0]	1 [0.039]	2 [0.079]	3 [0.118]	6 [0.236]

● Single acting pull type

mm [in.]

Code \ Bore		6	8	10	12	16	20	25	32	40	50
X	Standard type	7.2 [0.283]	8 [0.315]	8.3 [0.327]	7 [0.276]	7 [0.276]	11 [0.433]	11 [0.433]	13.5 [0.531]	14.5 [0.571]	12.5 [0.492]
	Y	11 [0.433]	10.3 [0.406]	11 [0.433]	9 [0.354]	9 [0.354]	12.5 [0.492]	14 [0.551]	13.5 [0.531]	15.5 [0.610]	14.5 [0.571]

● Single acting pull type

mm [in.]

Code \ Bore		12	16	20	25	32	40	50
X	Standard type	2.5 [0.098]	2.5 [0.098]	6.5 [0.256]	6.5 [0.256]	9 [0.354]	10 [0.394]	8 [0.315]
	Y	4.5 [0.177]	4.5 [0.177]	8 [0.315]	9.5 [0.374]	9 [0.354]	11 [0.433]	10 [0.394]

● Square rod cylinders with magnet

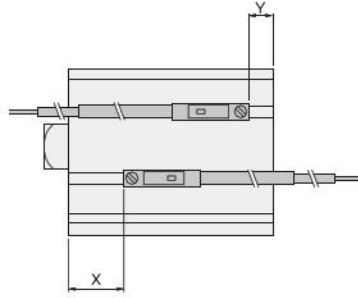

■ Solid state type

● Double acting type

mm [in.]

Code		Bore	20	25	32	40	50	63
X	Standard type	17.5 [0.689]	17.5 [0.689]	22.5 [0.886]	24.5 [0.965]	27.5 [1.083]	30 [1.181]	
	With bumper (-R)	21.5 [0.846]	22.5 [0.886]	24.5 [0.965]	26.5 [1.043]	30.5 [1.201]	30 [1.181]	
Y	Standard type	10 [0.394]	9 [0.354]	14 [0.551]	14.5 [0.571]	14.5 [0.571]	16 [0.630]	
	With bumper (-R)	8.5 [0.335]	9 [0.354]	6.5 [0.256]	8.5 [0.335]	11.5 [0.453]	16 [0.630]	

■ Reed switch type

● Double acting type

mm [in.]

Code		Bore	20	25	32	40	50	63
X	Standard type	13 [0.512]	13 [0.512]	18 [0.709]	20 [0.787]	23 [0.906]	25.5 [1.004]	
	With bumper (-R)	17 [0.669]	18 [0.709]	20 [0.787]	22 [0.866]	26 [1.024]	25.5 [1.004]	
Y	Standard type	5 [0.197]	4.5 [0.177]	4 [0.157]	6 [0.236]	10 [0.394]	11.5 [0.453]	
	With bumper (-R)	4 [0.157]	4.5 [0.177]	2 [0.079]	4 [0.157]	7 [0.276]	11.5 [0.453]	

● Double rod cylinders with magnet

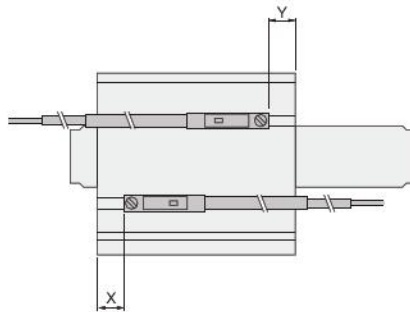

■ Solid state type

● Double acting type

mm [in.]

Code		Bore	6	8	10	12	16	20	25	32	40	50	63	80	100
X	Standard type	7.2 [0.283]	8 [0.315]	8.3 [0.327]	7 [0.276]	7 [0.276]	11 [0.433]	11 [0.433]	13.5 [0.531]	14.5 [0.571]	12.5 [0.492]	15.5 [0.610]	20.5 [0.807]	25 [0.984]	
	With bumper (-R)	—	—	—	10 [0.394]	10 [0.394]	15 [0.591]	16 [0.630]	15.5 [0.610]	16.5 [0.650]	14 [0.551]	15 [0.591]	20.5 [0.807]	25 [0.984]	
Y	Standard type	5.5 [0.217]	5.8 [0.228]	6 [0.236]	10 [0.394]	10 [0.394]	14 [0.551]	14.5 [0.571]	15.5 [0.610]	17.5 [0.689]	16.5 [0.650]	18 [0.709]	26.5 [1.043]	31.5 [1.240]	
	With bumper (-R)	—	—	—	12 [0.472]	12 [0.472]	15 [0.591]	14.5 [0.571]	6.5 [0.256]	15.5 [0.610]	15 [0.591]	18 [0.709]	26.5 [1.043]	31.5 [1.240]	

■ Reed switch type

● Double acting type

mm [in.]

Code		Bore	12	16	20	25	32	40	50	63	80	100
X	Standard type	2.5 [0.098]	2.5 [0.098]	6.5 [0.256]	6.5 [0.256]	9 [0.354]	10 [0.394]	8 [0.315]	10.5 [0.413]	16 [0.630]	20.5 [0.807]	
	With bumper (-R)	5.5 [0.217]	5.5 [0.217]	10.5 [0.413]	11.5 [0.453]	11 [0.433]	12 [0.472]	9.5 [0.374]	10.5 [0.413]	16 [0.630]	20.5 [0.807]	
Y	Standard type	5.5 [0.217]	5.5 [0.217]	9.5 [0.374]	10 [0.394]	11 [0.433]	13 [0.512]	12 [0.472]	13.5 [0.531]	22 [0.866]	27 [1.063]	
	With bumper (-R)	7.5 [0.295]	7.5 [0.295]	10.5 [0.413]	10 [0.394]	2 [0.079]	11 [0.433]	10.5 [0.413]	13.5 [0.531]	22 [0.866]	27 [1.063]	

● Single acting type

mm [in.]

Code		Bore	12	16	20	25	32	40	50
X	Standard type	15 [0.591]	15 [0.591]	14 [0.551]	14.5 [0.571]	15.5 [0.610]	17.5 [0.689]	16.5 [0.650]	
	With bumper (-R)	7 [0.276]	7 [0.276]	11 [0.433]	11 [0.433]	13.5 [0.531]	14.5 [0.571]	12.5 [0.492]	

● Single acting type

mm [in.]

Code		Bore	12	16	20	25	32	40	50
X	Standard type	10.5 [0.413]	10.5 [0.413]	9.5 [0.374]	10 [0.394]	11 [0.433]	13 [0.512]	12 [0.472]	
	With bumper (-R)	2.5 [0.098]	2.5 [0.098]	6.5 [0.256]	6.5 [0.256]	9 [0.354]	10 [0.394]	8 [0.315]	

● Tandem cylinders with magnet

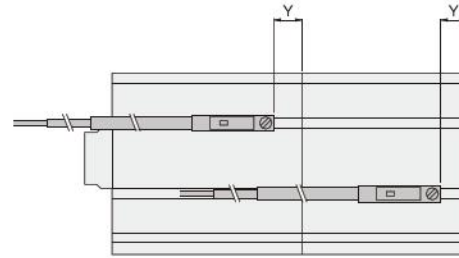
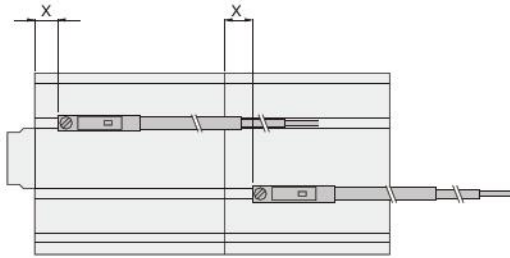

■ Solid state type

● Double acting type

mm [in.]

Code	Bore	12	16	20	25	32	40	50	63	80	100
X	Standard type	7 [0.276]	7 [0.276]	11 [0.433]	11 [0.433]	13.5 [0.531]	14.5 [0.571]	12.5 [0.492]	15 [0.591]	20 [0.787]	25 [0.984]
	With bumper (-R)	10 [0.394]	10 [0.394]	15 [0.591]	16 [0.630]	15.5 [0.610]	16.5 [0.650]	15.5 [0.610]	15 [0.591]	20 [0.787]	25 [0.984]
Y	Standard type	4 [0.157]	4 [0.157]	7.5 [0.295]	9 [0.354]	8.5 [0.335]	10.5 [0.413]	14.5 [0.571]	16 [0.630]	20 [0.787]	25 [0.984]
	With bumper (-R)	6 [0.236]	6 [0.236]	8.5 [0.335]	9 [0.354]	6.5 [0.256]	8.5 [0.335]	11.5 [0.453]	16 [0.630]	20 [0.787]	25 [0.984]

● Single acting push type

mm [in.]

Code	Bore	12	16	20	25	32	40	50
X		15 [0.591]	15 [0.591]	14 [0.551]	14.5 [0.571]	15.5 [0.610]	17.5 [0.689]	16.5 [0.650]
Y		1 [0.039]	1 [0.039]	4.5 [0.177]	5.5 [0.217]	6.5 [0.256]	7.5 [0.295]	10.5 [0.413]

■ Reed switch type

● Double acting type

mm [in.]

Code	Bore	12	16	20	25	32	40	50	63	80	100
X	Standard type	2.5 [0.098]	2.5 [0.098]	6.5 [0.256]	6.5 [0.256]	9 [0.354]	10 [0.394]	8 [0.315]	10.5 [0.413]	15.5 [0.610]	20.5 [0.807]
	With bumper (-R)	5.5 [0.217]	5.5 [0.217]	10.5 [0.413]	11.5 [0.453]	11 [0.433]	12 [0.472]	11 [0.433]	10.5 [0.413]	15.5 [0.610]	20.5 [0.807]
Y	Standard type	-0.5 [-0.020]	-0.5 [-0.020]	3 [0.118]	4.5 [0.177]	4 [0.157]	6 [0.236]	10 [0.394]	11.5 [0.453]	15.5 [0.610]	20.5 [0.807]
	With bumper (-R)	1.5 [0.059]	1.5 [0.059]	4 [0.157]	4.5 [0.177]	2 [0.079]	4 [0.157]	7 [0.276]	11.5 [0.453]	15.5 [0.610]	20.5 [0.807]

● Single acting push type

mm [in.]

Code	Bore	12	16	20	25	32	40	50
X		10.5 [0.413]	10.5 [0.413]	9.5 [0.374]	10 [0.394]	11 [0.433]	13 [0.512]	12 [0.472]
Y		-3.5 [-0.138]	-3.5 [-0.138]	0 [0]	1 [0.039]	2 [0.079]	3 [0.118]	6 [0.236]

## ● Dual stroke cylinders with magnet

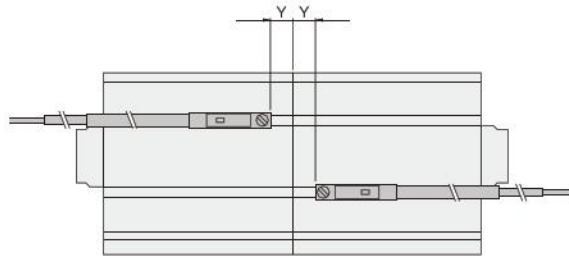
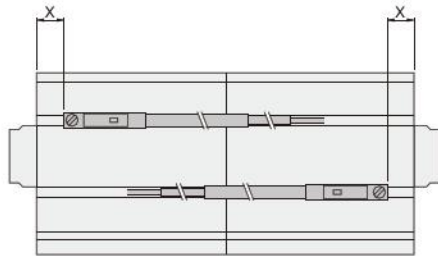

### ■ Solid state type

#### ● Double acting type

mm [in.]

Code	Bore	12	16	20	25	32	40	50	63	80	100
X	Standard type	7 [0.276]	7 [0.276]	11 [0.433]	11 [0.433]	13.5 [0.531]	14.5 [0.571]	12.5 [0.492]	15 [0.591]	20 [0.787]	25 [0.984]
	With bumper (-R)	10 [0.394]	10 [0.394]	15 [0.591]	16 [0.630]	15.5 [0.610]	16.5 [0.650]	14 [0.551]	15 [0.591]	20 [0.787]	25 [0.984]
Y	Standard type	4 [0.157]	4 [0.157]	7.5 [0.295]	9 [0.354]	8.5 [0.335]	10.5 [0.413]	14.5 [0.571]	16 [0.630]	20 [0.787]	25 [0.984]
	With bumper (-R)	6 [0.236]	6 [0.236]	8.5 [0.335]	9 [0.354]	6.5 [0.256]	8.5 [0.335]	13.5 [0.531]	16 [0.630]	20 [0.787]	25 [0.984]

#### ● Single acting push type

mm [in.]

Code	Bore	12	16	20	25	32	40	50
X	15 [0.591]	15 [0.591]	14 [0.551]	14.5 [0.571]	15.5 [0.610]	17.5 [0.689]	16.5 [0.650]	
Y	1 [0.039]	1 [0.039]	7.5 [0.295]	5.5 [0.217]	6.5 [0.256]	7.5 [0.295]	10.5 [0.413]	

#### ● Single acting pull type

mm [in.]

Code	Bore	12	16	20	25	32	40	50
X	7 [0.276]	7 [0.276]	11 [0.433]	11 [0.433]	13.5 [0.531]	14.5 [0.571]	12.5 [0.492]	
Y	9 [0.354]	9 [0.354]	12.5 [0.492]	14 [0.551]	13.5 [0.531]	15.5 [0.610]	14.5 [0.571]	

### ■ Reed switch type

#### ● Double acting type

mm [in.]

Code	Bore	12	16	20	25	32	40	50	63	80	100
X	Standard type	2.5 [0.098]	2.5 [0.098]	6.5 [0.256]	6.5 [0.256]	9 [0.354]	10 [0.394]	8 [0.315]	10.5 [0.413]	15.5 [0.610]	20.5 [0.807]
	With bumper (-R)	5.5 [0.217]	5.5 [0.217]	10.5 [0.413]	11.5 [0.453]	11 [0.433]	12 [0.472]	9.5 [0.374]	10.5 [0.413]	15.5 [0.610]	20.5 [0.807]
Y	Standard type	-0.5 [-0.020]	-0.5 [-0.020]	3 [0.118]	4.5 [0.177]	4 [0.157]	6 [0.236]	10 [0.394]	11.5 [0.453]	15.5 [0.610]	20.5 [0.807]
	With bumper (-R)	1.5 [0.059]	1.5 [0.059]	4 [0.157]	4.5 [0.177]	2 [0.079]	4 [0.157]	9 [0.354]	11.5 [0.453]	15.5 [0.610]	20.5 [0.807]

#### ● Single acting push type

mm [in.]

Code	Bore	12	16	20	25	32	40	50
X	10.5 [0.413]	10.5 [0.413]	9.5 [0.374]	10 [0.394]	11 [0.433]	13 [0.512]	12 [0.472]	
Y	-3.5 [-0.138]	-3.5 [-0.138]	3 [0.118]	1 [0.039]	2 [0.079]	3 [0.118]	6 [0.236]	

#### ● Single acting pull type

mm [in.]

Code	Bore	12	16	20	25	32	40	50
X	2.5 [0.098]	2.5 [0.098]	6.5 [0.256]	6.5 [0.256]	9 [0.354]	10 [0.394]	8 [0.315]	
Y	4.5 [0.177]	4.5 [0.177]	8 [0.315]	9.5 [0.374]	9 [0.354]	11 [0.433]	10 [0.394]	

## ● Lateral load resistant cylinders with magnet

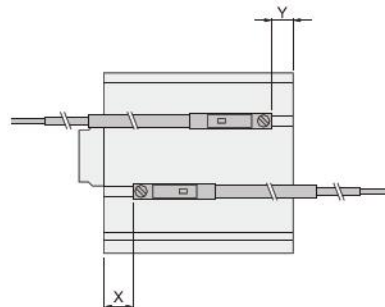

### ■ Solid state type

#### ● Double acting type

mm [in.]

Code	Bore	12	16	20	25	32	40	50	63	80	100
X	10 [0.394]	10 [0.394]	15 [0.591]	16 [0.630]	15.5 [0.610]	16.5 [0.650]	15.5 [0.610]	17.5 [0.689]	26.5 [1.043]	31.5 [1.240]	
Y	6 [0.236]	6 [0.236]	8.5 [0.335]	9 [0.354]	6.5 [0.256]	8.5 [0.335]	11.5 [0.453]	13.5 [0.531]	18.5 [0.728]	23.5 [0.925]	

### ■ Reed switch type

#### ● Double acting type

mm [in.]

Code	Bore	12	16	20	25	32	40	50	63	80	100
X	5.5 [0.217]	5.5 [0.217]	10.5 [0.413]	11.5 [0.453]	11 [0.433]	12 [0.472]	11 [0.433]	13 [0.512]	22 [0.866]	27 [1.063]	
Y	1.5 [0.059]	1.5 [0.059]	4 [0.157]	4.5 [0.177]	2 [0.079]	4 [0.157]	7 [0.276]	9 [0.354]	14 [0.551]	19 [0.748]	

● Long stroke cylinders with magnet

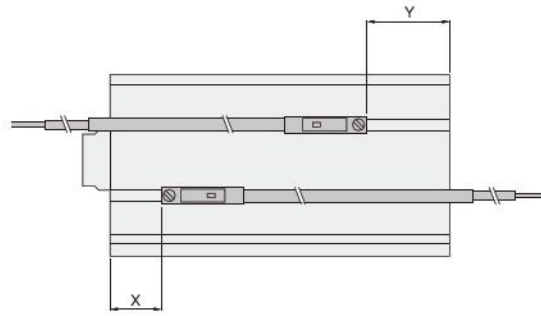

■ Solid state type

● Double acting type

mm [in.]

Code \ Bore	12	16	20	25	32	40	50	63	80	100
<b>X</b>	15 [0.591]	15 [0.591]	20 [0.787]	21 [0.827]	20.5 [0.807]	21.5 [0.846]	20.5 [0.807]	22.5 [0.886]	31.5 [1.240]	36.5 [1.437]
<b>Y</b>	12 [0.472]	12 [0.472]	15 [0.591]	14.5 [0.571]	13.5 [0.531]	15.5 [0.610]	12.5 [0.492]	13.5 [0.531]	18.5 [0.728]	23.5 [0.925]

■ Reed switch type

● Double acting type

mm [in.]

Code \ Bore	12	16	20	25	32	40	50	63	80	100
<b>X</b>	10.5 [0.413]	10.5 [0.413]	15.5 [0.610]	16.5 [0.650]	16 [0.630]	17 [0.669]	16 [0.630]	18 [0.709]	27 [1.063]	32 [1.260]
<b>Y</b>	7.5 [0.295]	7.5 [0.295]	10.5 [0.413]	10 [0.394]	9 [0.354]	11 [0.433]	8 [0.315]	9 [0.354]	14 [0.551]	19 [0.748]

● End keep cylinder with magnet

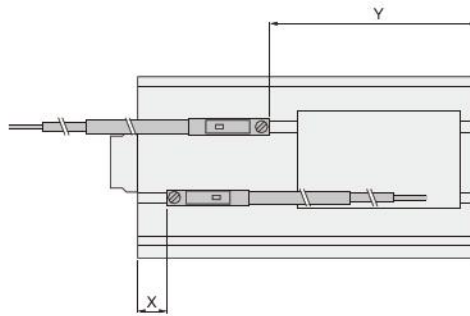

■ Solid state type

● Head side end keep

mm [in.]

Code \ Bore	16	20	25	32	40	50	63
<b>X</b>	15.5 [0.610]	20.5 [0.807]	21.5 [0.846]	20.5 [0.807]	21.5 [0.846]	20.5 [0.807]	22.5 [0.886]
<b>Y</b>	36.5 [1.437]	34.5 [1.358]	34.5 [1.358]	43.5 [1.713]	45.5 [1.791]	51.5 [2.028]	54.5 [2.146]

■ Solid state type

● Rod side end keep

mm [in.]

Code \ Bore	16	20	25	32	40	50	63
<b>X</b>	35.5 [1.398]	35.5 [1.398]	36.5 [1.437]	45.5 [1.791]	46.5 [1.831]	55.5 [2.185]	57.5 [2.264]
<b>Y</b>	11.5 [0.453]	14.5 [0.571]	14.5 [0.571]	13.5 [0.531]	15.5 [0.610]	11.5 [0.453]	13.5 [0.531]

■ Reed switch type

● Head side end keep

mm [in.]

Code \ Bore	16	20	25	32	40	50	63
<b>X</b>	11 [0.433]	16 [0.630]	17 [0.669]	16 [0.630]	17 [0.669]	16 [0.630]	16 [0.630]
<b>Y</b>	32 [1.260]	30 [1.181]	30 [1.181]	39 [1.535]	41 [1.614]	47 [1.850]	50 [1.969]

■ Reed switch type

● Rod side end keep

mm [in.]

Code \ Bore	16	20	25	32	40	50	63
<b>X</b>	31 [1.220]	31 [1.220]	32 [1.260]	41 [1.614]	42 [1.654]	51 [2.008]	53 [2.087]
<b>Y</b>	7 [0.276]	10 [0.394]	10 [0.394]	9 [0.354]	11 [0.433]	7 [0.276]	9 [0.354]

# Handling Instructions and Precautions

## Body mounting

Jig cylinder mounting holes include both through holes with female mounting thread, and dedicated female mounting threads, for a variety of mountings. For details, see the diagrams below.

### Standard cylinders, Double rod cylinders

- Standard cylinders
- Long stroke cylinders

- Double rod cylinders
- End keep cylinders

- Lateral load resistant cylinders

●  $\phi 6 \sim \phi 12$

●  $\phi 16$

●  $\phi 20, \phi 25$

●  $\phi 32 \sim \phi 100$

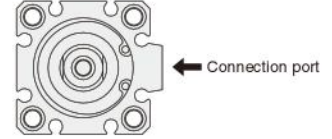
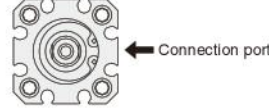
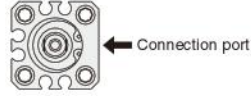
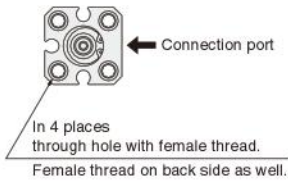

Remark: Mounting methods are the same regardless of bore sizes.

### Non-rotating cylinders

●  $\phi 6, \phi 8, \phi 10$

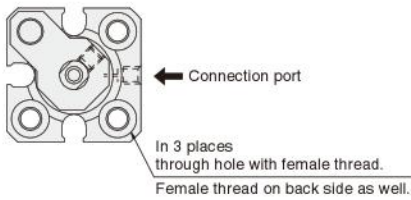

### Square rod cylinders

●  $\phi 20, \phi 25$

●  $\phi 32 \sim \phi 63$

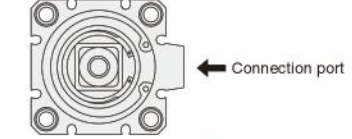
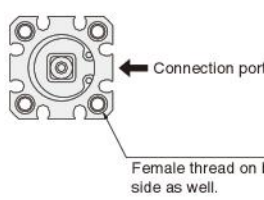

Remark: Mounting methods are the same regardless of bore sizes. However, the mounting method for "with centering location" differs from the figure above. See p.153.

### Tandem cylinders

●  $\phi 12$

●  $\phi 16$

●  $\phi 20, \phi 25$

●  $\phi 32 \sim \phi 100$

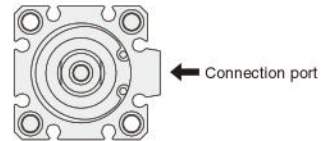
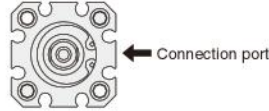
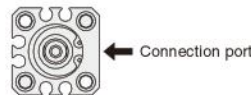
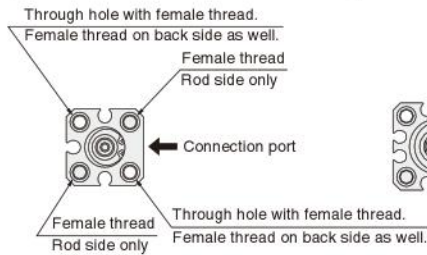

Remark: Mounting methods are the same regardless of bore sizes.

### Dual stroke cylinders

●  $\phi 12$

●  $\phi 16$

●  $\phi 20, \phi 25$

●  $\phi 32 \sim \phi 100$

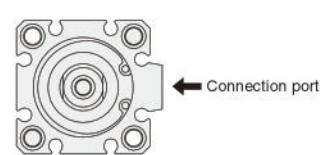
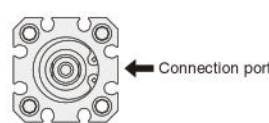
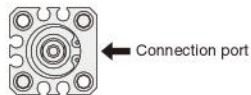
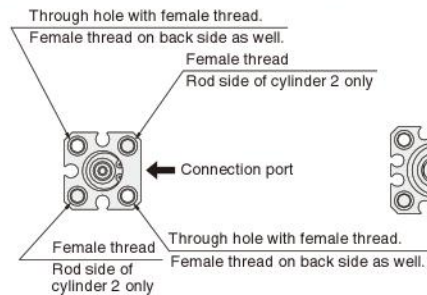

Remark: Mounting methods are the same regardless of bore sizes.

- Notes: 1. Avoid applying lateral loads on the piston rod, with the exception of Lateral load resistant cylinders, Long stroke cylinders, and End keep cylinders.  
 2. When using through holes for mounting, always use the supplied dedicated washers. (except  $\phi 6, \phi 8,$  and  $\phi 10$ )  
 3. Mount an external stopper, etc., to prevent the cylinder from being subjected to direct shocks during operation.

### Tightening thread of the end of piston rod

Since a tool (thin wrench) has been prepared for holding the piston rod when tightening the rod end thread, consult us.

Order code: L115069



- Always use the supplied dedicated washer whenever using a through bolt to directly mount the cylinder body in place.\* Use the bolts shown in the table below to mount in place. And for bolts used for direct mounting, see p.209.

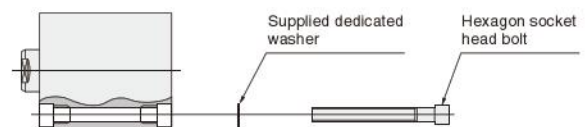

\*Washer not available for bore sizes  $\phi 6, \phi 8,$  and  $\phi 10$ .

Bore size mm [in.]	6	8	10	12	16	20	25	32	40	50	63	80	100
	[0.236]	[0.315]	[0.394]	[0.472]	[0.630]	[0.787]	[0.984]	[1.260]	[1.575]	[1.969]	[2.480]	[3.150]	[3.940]
Hexagon socket head bolt nominal size	M3	M3	M3	M3	M3	M3	M4	M4	M5	M6	M6	M8	M10

**Bracket mounting**

- Foot mounting brackets cannot be installed on tandem cylinders and dual stroke cylinders.
- Flange mounting brackets cannot be installed on the head side of tandem cylinders and the stroke 1 side of dual stroke cylinders.
- Clevis mounting brackets cannot be installed on anything except for lateral load resistant cylinders, long stroke cylinders, and end keep cylinders.

**Non-standard stroke**

- In most cases, body cutting is used for the manufacturing for non-standard strokes. However, body cutting is not used for strokes of less than 5mm for  $\phi 12$  [0.472in.]~ $\phi 40$  [1.575in.], and strokes of less than 10mm for  $\phi 50$  [1.969in.]~ $\phi 100$  [3.940in.]. The collar packed is used for these cases. Moreover, sizes  $\phi 6$  [0.236in.]~ $\phi 10$  [0.394in.] are collar packed only. For delivery, consult us. Rod side end keep cylinders cannot be collar packed.
- Dimensions
  1. Additional strokes obtained by body cutting remain classed as non-standard strokes.
  2. Additional strokes obtained by collar packed are classed as standard strokes in the longer one.

**Lateral Load**

- Keep the lateral load on the rod end of the lateral load resistant cylinder, long stroke cylinder, and end keep cylinder, at or below the values shown in the graphs below.  
Note: Avoid applying lateral load on any cylinder types other than the lateral load resistant cylinder, long stroke cylinder, and end keep cylinder.

**● Lateral load resistant cylinders**

**● Standard type (CBDA)**

●  $\phi 12$  [0.472in.]~ $\phi 20$  [0.787in.]

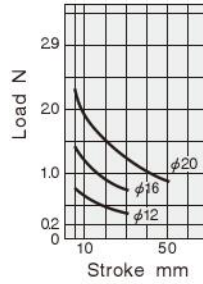

●  $\phi 25$  [0.984in.]~ $\phi 40$  [1.575in.]

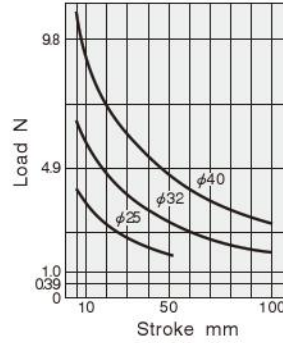

●  $\phi 50$  [1.969in.]~ $\phi 100$  [3.940in.]

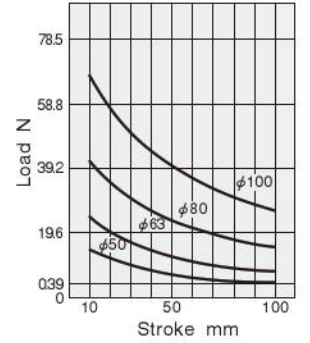

1N = 0.2248lbf.  
1mm = 0.0394in.

**● Cylinder with magnet (CBDAS)**

●  $\phi 12$  [0.472in.]~ $\phi 20$  [0.787in.]

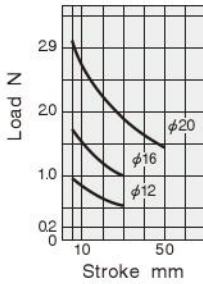

●  $\phi 25$  [0.984in.]~ $\phi 50$  [1.969in.]

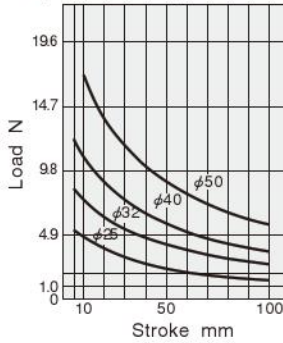

●  $\phi 63$  [2.480in.]~ $\phi 100$  [3.940in.]

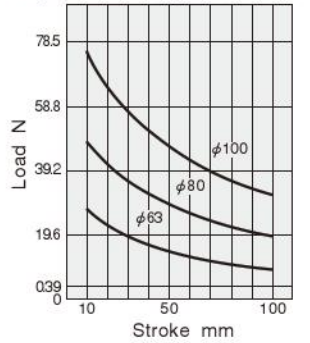

1N = 0.2248lbf.  
1mm = 0.0394in.

**● Long stroke cylinders, End keep cylinders**

● Standard type (CCDA,CCDAK)

●  $\phi 25$  [0.984in.]~ $\phi 50$  [1.969in.]

●  $\phi 63$  [2.480in.]~ $\phi 100$  [3.940in.]

●  $\phi 12$  [0.472in.]~ $\phi 20$  [0.787in.]

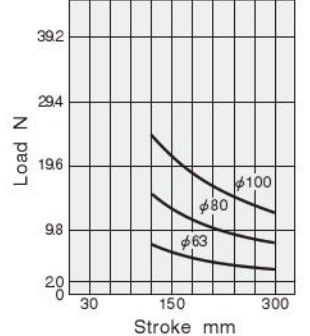
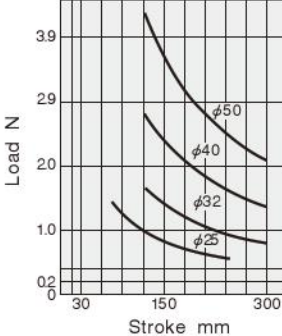
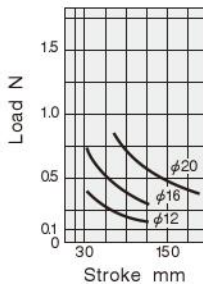

1N = 0.2248lbf.  
1mm = 0.0394in.

**● Cylinder with magnet (CCDAS, CCDAKS)**

●  $\phi 12$  [0.472in.]~ $\phi 20$  [0.787in.]

●  $\phi 25$  [0.984in.]~ $\phi 40$  [1.575in.]

●  $\phi 50$  [1.969in.]~ $\phi 100$  [3.940in.]

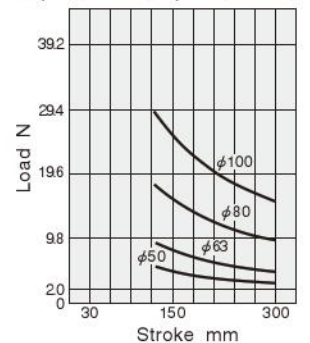
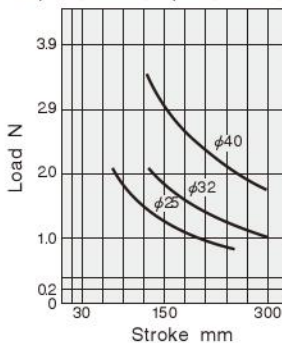
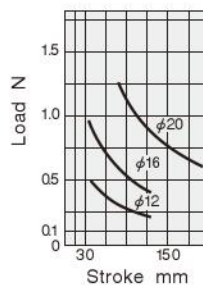

1N = 0.2248lbf.  
1mm = 0.0394in.

## Handling Instructions and Precautions

### Single acting cylinders

Standard cylinders single acting push type  
Standard cylinders single acting pull type  
Double rod cylinders single acting type  
Tandem cylinders single acting push type  
Dual stroke cylinders single acting push type  
Dual stroke cylinders single acting pull type

If in the above types' application, air is being continuously applied from a connection port, and the spring remains in a compressed state for long periods of time, the piston may sometimes fail to return to its original position even after the air is exhausted. If equipment is to be used in this way over long periods of time, consult us.

### End keep cylinder

#### ● Control circuit

1. For control of Jig end keep cylinders, we recommend the use of 2-position, 4-, 5-port valves. Avoid the use of a control circuit of ABR connections (exhaust centers) with 3-position valves that exhaust air from 2 ports.
2. Always use meter-out control for speed control. Meter-in control may result in failure of the locking mechanism to release.

Notes: 1. It is dangerous to supply air to a connection port on a side with a locking mechanism while already exhausted, because the piston rod could suddenly extend (retract). In addition, it could also cause galling of the lock piston and piston rod, resulting in defective operation. Always supply air to the connection port on the opposite side to ensure back pressure is applied.

2. When restarting operations after air has been exhausted from the cylinder due to completion of operations or to an emergency stop, always start by supplying air to the connection port on the opposite side of the locking mechanism.
3. Connect the valve port A (NC) to the connection port on the side with the locking mechanism.

#### ● Manual operation of the locking mechanism

While the locking mechanism is normally released automatically through cylinder operations, it can also be released manually. For manual release, insert an M3 × 0.5 screw that has 30mm [1.18in.] below head length into the manual override opening, thread it in about 3 turns into the internal lock piston, and then pull up the screw. To maintain the manual override for adjustment, etc., thread the locknut onto the screw and, with the locking mechanism in a released state, tighten the locknut against the cylinder.

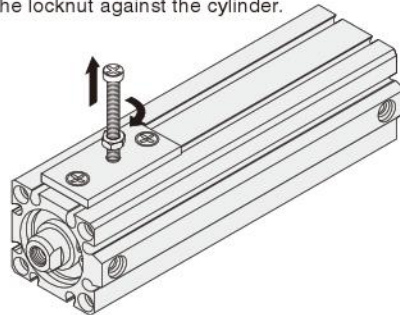

Notes: 1. It is dangerous to release the lock when a load (weight) is present on the piston rod, because it may cause a sudden fall or cause the unintended piston rod's extension (retraction). In this case, always supply air to the connection port opposite the one adjacent to the locking mechanism before releasing the locking mechanism.

2. If the locking mechanism cannot easily be released even with manual override, it could be the result of galling of the lock piston and piston rod. In this case, supply air to the connection port opposite the one adjacent to the locking mechanism before releasing the locking mechanism.
3. Because water, oil, dust, etc., entering via the manual override opening could be a cause of defective locking or other erratic operation, use a cover, etc., for protection when using in locations subject to dripping water, dripping oil, or to large amounts of dust, etc.

### Sensor switch

In the standard cylinder, a magnet for the sensor switch is not built-in.

To install a sensor switch, a cylinder with a built-in magnet for the sensor switch is required.

Notes: 1. For the sensor switch mounting location and moving ranges, see p.199.  
2. Contact protection measures are required for connecting inductive loads to reed sensor switches or for when capacitive surges are generated. For contact protection measures, see p.1566.

### Piping

Always thoroughly blow off (use compressed air) the tubing before connecting it to the cylinder. Entering chips, sealing tape, rust, etc., generated during piping work could result in air leaks or other defective operation.

### Atmosphere

1. If using in locations subject to dripping water, dripping oil, etc., or to large amounts of dust, use a cover to protect the unit.
2. The product cannot be used when the media or ambient atmosphere contains any of the substances listed below.  
Organic solvents, phosphate ester type hydraulic oil, sulphur dioxide, chlorine gas, or acids, etc.

### Lubrication

The product can be used without lubrication, if lubrication is required, use Turbine Oil Class 1 (ISO VG32) or equivalent.

Avoid using spindle oil or machine oil.

# OPTIONAL ROD END SHAPE PATTERNS

Use an order form of rod end pattern and fill the items on the selected one from among 22 types of optional patterned shapes to obtain made-to-order cylinders of non-standard rod end shapes. The optional rod end shapes can be applied to the entire Jig Cylinders C Series. For the order form containing the optional patterned shapes, contact us.  
(Except  $\phi 6$ ,  $\phi 8$ ,  $\phi 10$ )

## Order Codes

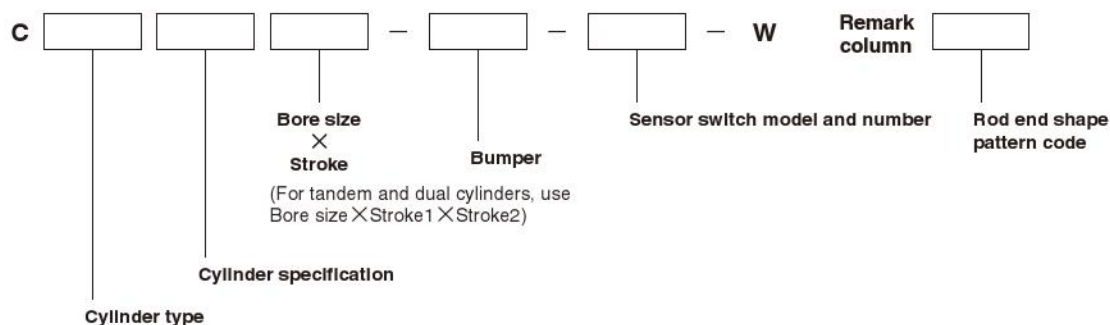

## Piston Rod End Shape Pattern Diagrams (22 Types)

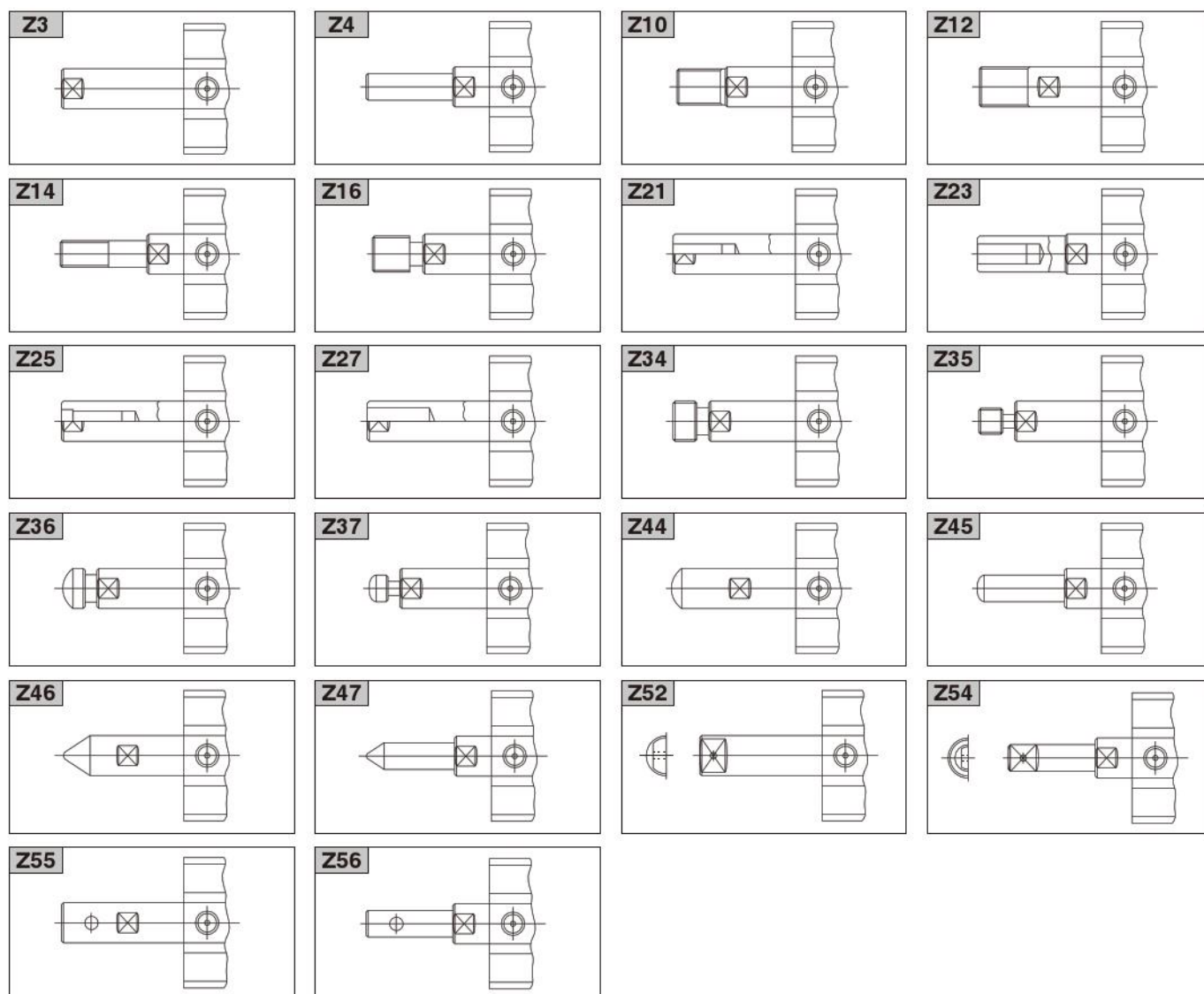

# MOUNTING SCREWS FOR JIG CYLINDERS



● Some types of mounting screws specifically for the Jig Cylinders are available.

Use the order codes below to place orders.

## List of Order Codes

① Mounting screw type: JIS B 1176 Hexagon socket head cap screws

② Surface treatment: Nickel plated

Applicable cylinder bore size mm [in.]	Mounting screw order code	Screw size	Number of supplied screws		
<b>6 [0.236]</b> <b>8 [0.315]</b> <b>10 [0.394]</b> <b>12 [0.472]</b> <b>16 [0.630]</b> <b>20 [0.787]</b>	CRK124	M3×25	2		
	CRK125	M3×30			
	CRK126	M3×35			
	CRK127	M3×40			
	CRK128	M3×45			
	25 [0.984] 32 [1.260]	CRK129	M3×50	4	
		CRK130	M3×30		
		CRK131	M3×35		
		CRK132	M3×40		
		CRK133	M3×45		
CRK134		M3×50			
CRK135		M4×30			
CRK136		M4×35			
40 [1.575]	CRK137	M4×40	4		
	CRK138	M4×45			
	CRK139	M4×50			
	CRK140	M4×55			
	CRK141	M4×60			
	CRK142	M4×65			
	CRK143	M4×70			
	CRK144	M4×75			
	50 [1.969] 63 [2.480]	CRK145		M5×35	4
		CRK146		M5×40	
CRK147		M5×45			
CRK148		M5×50			
CRK149		M5×55			
CRK150		M5×60			
CRK151		M5×65			
CRK152		M5×70			
CRK153		M5×75			
CRK154		M5×80			
50 [1.969] 63 [2.480]	CRK155	M5×85	4		
	CRK156	M5×90			
	CRK157	M5×100			
	CRK158	M5×110			
	CRK159	M6×40			
	CRK160	M6×45			
	CRK161	M6×50			
	CRK162	M6×55			
	CRK163	M6×60			
	CRK164	M6×65			
	CRK165	M6×70			
CRK166	M6×75				
CRK167	M6×80				
CRK168	M6×85				
CRK169	M6×90				
CRK170	M6×100				
CRK171	M6×110				
CRK172	M6×120				
CRK173	M6×130				
CRK174	M6×140				
CRK175	M6×150				

Applicable cylinder bore size mm [in.]	Mounting screw order code	Screw size	Number of supplied screws
<b>80 [3.150]</b>	CRK176	M8×60	4
	CRK177	M8×65	
	CRK178	M8×70	
	CRK179	M8×75	
	CRK180	M8×80	
	CRK181	M8×85	
	CRK182	M8×90	
	CRK183	M8×95	
	CRK184	M8×100	
	CRK185	M8×110	
	CRK186	M8×120	
	CRK187	M8×130	
	CRK188	M8×140	
	CRK189	M8×150	
	CRK190	M8×160	
	<b>100 [3.940]</b>	CRK191	
CRK192		M10×65	
CRK193		M10×70	
CRK194		M10×75	
CRK195		M10×80	
CRK196		M10×85	
CRK197		M10×90	
CRK198		M10×95	
CRK199		M10×100	
CRK200		M10×110	
CRK201		M10×120	
CRK202	M10×130		
CRK203	M10×140		
CRK204	M10×150		
CRK205	M10×160		
CRK206	M10×170		