

# Multi functional support for small movements, MULTI MOUNT CYLINDERS

In addition to the directly installed side mounting type, 3 types of mounting brackets provide appropriate responses for various mounting requirements.







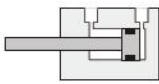

Moreover, this is a design that secures a high degree of parallel and perpendicular accuracy in relation to the piston rod axial center and mounting surface in any mounting type.

This combination of a square and compact body with mounting brackets has further broadened the degree of freedom for equipment design.

- Even while preserving the basic design of previous types, we have made overall improvements through the addition of a built-in rubber bumper and other changes.  
We have not only expanded the series but have also boosted reliability and utility.
- Even the non-rotating type is now available in the double acting type, the single acting push/pull types, and the double acting double rod type, to respond to diversified needs with high non-rotating precision by the guide pin.
- Although the 3 types of sensor switches are all compact with cross section dimensions of  $\square 4\text{mm}$  [0.157in.], mounting to the cylinder and adjusting the position are easy.  
Comes with a movement indicator lamp that makes it possible to monitor movement from 4 directions, providing multi functional support for small movements.

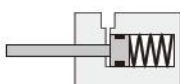
## Basic Type and Configuration

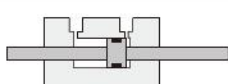





Page where specifications are shown — 97



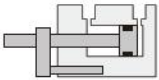



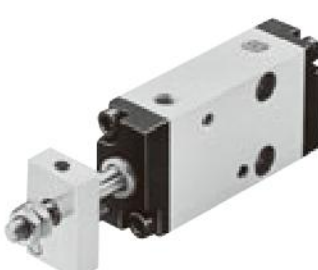

<b>Double acting type BDA</b>	
	
<b>Single acting push type BSA</b>	
	
<b>Single acting pull type BTA</b>	
	
<b>Double acting double rod type BDAD</b>	
	

# Mounting Bracket Configuration and Application:

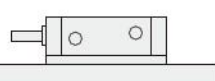
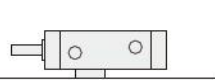
For the order codes of mounting brackets only, see p.125.

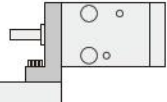
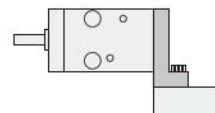
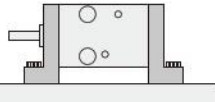
Page where specifications are shown — 113

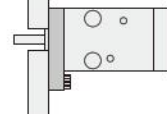
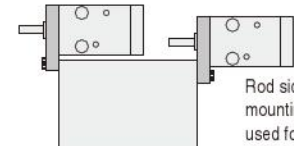
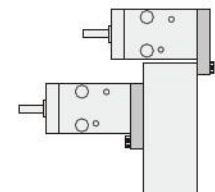
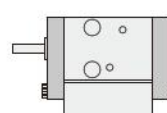
<p>Non-rotating double acting type <b>BDAL</b></p>	
	
<p>Non-rotating single acting push type <b>BSAL</b></p>	
	
<p>Non-rotating single acting pull type <b>BTAL</b></p>	
	
<p>Non-rotating double acting double rod type <b>BDADL</b></p>	
	

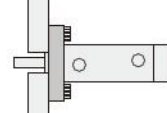
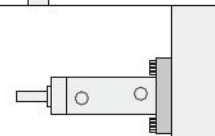
<p><b>Side mount (Standard)</b></p> 	 <p>Side mounting thru hole used for direct installation.</p>  <p>Plate-like spacer used for easy piston rod center adjustment.</p>  <p>Collar and counter-bore of the cylinder body used for easy piston rod center adjustment.</p>
<p><b>Foot A mount</b></p> <p>Foot mounting brackets are not available for the rod sides of the non-rotating and non-rotating double rod type.</p> 	 <p>Rod side foot mounting bracket used for one-side support.</p>  <p>Head side foot mounting bracket used for one-side support.</p>  <p>Foot mounting bracket on both sides used for rigid mounting.</p>
<p><b>Flange A mount</b></p> 	 <p>Rod side flange mounting brackets used for panel mount.</p>  <p>Rod side flange mounting brackets used for wall mount.</p>  <p>Head side flange mounting brackets used for wall mount.</p>  <p>Flange mounting brackets at both sides used for sandwich mount. (Should be adjusted at a field.)</p>
<p><b>Flange B mount</b></p> 	 <p>Rod side flange mounting bracket used for panel mount.</p>  <p>Head side flange mounting bracket used for panel mount.</p>

# MULTI MOUNT CYLINDERS

## Standard Cylinders

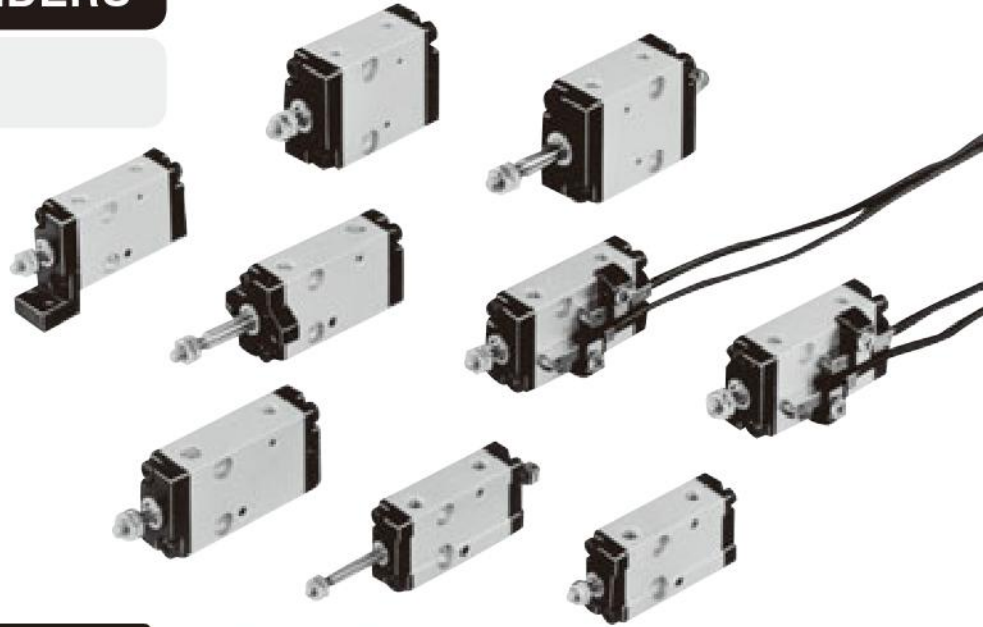

### Symbols

- Double acting type (BDA)
- Single acting push type (BSA)



- Single acting pull type (BTA)
- Double acting double rod type (BDAD)



### Cylinder Thrust

Bore size mm [in.]	Piston rod diameter mm [in.]	Operation type	Pressure area mm <sup>2</sup> [in <sup>2</sup> ]	Air pressure MPa [psi.]							
				0.1 [15]	0.2 [29]	0.3 [44]	0.4 [58]	0.5 [73]	0.6 [87]	0.7 [102]	
6 [0.236]	3 [0.118]	Double acting type	Push side	28.2 [0.0437]	—	5.6 [1.26]	8.5 [1.91]	11.3 [2.54]	14.1 [3.17]	16.9 [3.80]	19.7 [4.43]
			Pull side	21.2 [0.0329]	—	4.2 [0.94]	6.4 [1.44]	8.5 [1.91]	10.6 [2.38]	12.7 [2.85]	14.8 [3.33]
		Single acting push type	Push side	28.2 [0.0437]	—	1.7 [0.38]	4.6 [1.03]	7.4 [1.66]	10.2 [2.29]	13 [2.92]	15.8 [3.55]
			Pull side	21.2 [0.0329]	—	—	2.5 [0.56]	4.6 [1.03]	6.7 [1.51]	8.8 [1.98]	10.9 [2.45]
10 [0.394]	5 [0.197]	Double acting type	Push side	78.5 [0.1217]	7.9 [1.78]	15.7 [3.53]	23.6 [5.31]	31.4 [7.06]	39.3 [8.83]	47.1 [10.59]	55 [12.36]
			Pull side	58.9 [0.0913]	5.9 [1.33]	11.8 [2.65]	17.7 [3.98]	23.6 [5.31]	29.5 [6.63]	35.3 [7.94]	41.2 [9.26]
		Single acting push type	Push side	78.5 [0.1217]	—	7.9 [1.78]	15.8 [3.55]	23.6 [5.31]	31.5 [7.08]	39.3 [8.83]	47.2 [10.61]
			Pull side	58.9 [0.0913]	—	4 [0.90]	9.9 [2.23]	15.8 [3.55]	21.7 [4.88]	27.5 [6.18]	33.4 [7.51]
16 [0.630]	6 [0.236]	Double acting type	Push side	201 [0.312]	20.1 [4.52]	40.2 [9.04]	60.3 [13.56]	80.4 [18.07]	100.5 [22.59]	120.6 [27.11]	140.7 [31.63]
			Pull side	172 [0.267]	17.2 [3.87]	34.4 [7.73]	51.6 [11.60]	68.8 [15.47]	86 [19.33]	103.2 [23.20]	120.4 [27.07]
		Single acting push type	Push side	201 [0.312]	—	18.6 [4.18]	38.7 [8.70]	58.8 [13.22]	78.9 [17.74]	99 [22.26]	119.1 [26.77]
			Pull side	172 [0.267]	—	12.8 [2.88]	30 [6.74]	47.2 [10.61]	64.4 [14.48]	81.6 [18.34]	98.8 [22.21]

Note: For the double acting double rod type, see the double acting type pull side.

### Spring Return Force (Only for Single Acting Type)





Bore size mm [in.]	Item	Zero stroke			End of stroke
		5	10	15	5, 10, 15
6 [0.236]	Stroke mm	2.9 [0.65]	2.5 [0.56]	2.0 [0.45]	3.9 [0.88]
10 [0.394]	Stroke mm	6.9 [1.55]	4.9 [1.10]	2.9 [0.65]	7.8 [1.75]
16 [0.630]	Stroke mm	17.7 [3.98]	13.7 [3.08]	9.8 [2.20]	21.6 [4.86]

### Specifications

Item		Bore size mm [in.]		
		6 [0.236]	10 [0.394]	16 [0.630]
Media		Air		
Operating pressure range MPa [psi.]	Double acting type	0.15~0.7 [22~102]	0.1~0.7 [15~102]	0.08~0.7 [12~102]
	Single acting push type	0.2~0.7 [29~102]	0.15~0.7 [22~102]	0.15~0.7 [22~102]
	Single acting pull type	0.3~0.7 [44~102]	0.2~0.7 [29~102]	0.2~0.7 [29~102]
	Double acting double rod type	0.2~0.7 [29~102]	0.15~0.7 [22~102]	0.1~0.7 [15~102]
Proof pressure	MPa [psi.]	1.03 [149]		
Operating temperature range	°C [°F]	0~60 [32~140]		
Operating speed range	mm/s [in./sec.]	50~500 [2.0~19.7]		
Cushion		Rubber bumper		
Lubrication		Not required (If lubrication is required, use Turbine Oil Class 1 [ISO VG32] or equivalent.)		
Port size		M5×0.8		
Stroke tolerance	mm [in.]	+1 0 [ +0.039 0 ]		

### Operation Type, Bore Size, and Stroke

Operation type	Bore size	Standard strokes	
		mm	
Double acting type	6	5, 10, 15, 20, 25, 30	
	10	5, 10, 15, 20, 25, 30	
	16	5, 10, 15, 20, 25, 30	
Single acting push type Single acting pull type	6	5, 10, 15	
	10	5, 10, 15	
	16	5, 10, 15	
Double acting double rod type	6	5, 10, 15, 20, 25, 30	
	10	5, 10, 15, 20, 25, 30	
	16	5, 10, 15, 20, 25, 30	

Double acting type	Single acting push type	Single acting pull type	Double acting double rod type
Page where dimensions are shown _____ 101	Page where dimensions are shown _____ 104	Page where dimensions are shown _____ 107	Page where dimensions are shown _____ 110
			
<b>BDA</b>	<b>BSA</b>	<b>BTA</b>	<b>BDAD</b>

### Mass

Operation type	Bore size mm [in.]	Stroke mm	Mass of side mount		Additional mass																
			Standard cylinder	Cylinder with magnet	Double rod	With 1 sensor switch (Only for cylinder with magnet type)				Rod side mounting bracket			Head side mounting bracket								
						ZC130□	ZC153□	CS5T□	CS11T□	Foot A mount	Flange A mount	Flange B mount	Foot A mount	Flange A mount	Flange B mount						
Double acting type	<b>6</b> [0.236]	5	21 [0.74]	24 [0.85]	4 [0.14]	20 [0.71]	10 [0.35]	1 [0.04]	1 [0.04]	15 [0.53]	5 [0.18]	5 [0.18]	5	10	15	20	25	30	36 [1.27]	39 [1.38]	
		10	24 [0.85]	27 [0.95]																	
		15	27 [0.95]	30 [1.06]																	
		20	30 [1.06]	33 [1.16]																	
		25	33 [1.16]	36 [1.27]																	
		30	36 [1.27]	39 [1.38]																	
	<b>10</b> [0.394]	5	37 [1.31]	43 [1.52]	8 [0.28]	20 [0.71]	16 [0.56]	2 [0.07]	2 [0.07]	24 [0.85]	8 [0.28]	8 [0.28]	5	10	15	20	25	30	37 [1.31]	43 [1.52]	
		10	41 [1.45]	47 [1.66]																	
		15	45 [1.59]	51 [1.80]																	
		20	49 [1.73]	55 [1.94]																	
		25	53 [1.87]	59 [2.08]																	
		30	57 [2.01]	63 [2.22]																	
	<b>16</b> [0.630]	5	79 [2.79]	92 [3.25]	16 [0.56]	20 [0.71]	33 [1.16]	4 [0.14]	4 [0.14]	53 [1.87]	17 [0.60]	17 [0.60]	5	10	15	20	25	30	79 [2.79]	92 [3.25]	
		10	86 [3.03]	99 [3.49]																	
		15	93 [3.28]	106 [3.74]																	
		20	100 [3.53]	113 [3.99]																	
		25	107 [3.77]	120 [4.23]																	
		30	114 [4.02]	127 [4.48]																	
Single acting push type	<b>6</b> [0.236]	5	25 [0.88]	28 [0.99]	—	20 [0.71]	10 [0.35]	1 [0.04]	1 [0.04]	15 [0.53]	5 [0.18]	5 [0.18]	5	10	15	20	25	30	25 [0.88]	28 [0.99]	
		10	28 [0.99]	31 [1.09]																	
		15	31 [1.09]	34 [1.20]																	
	<b>10</b> [0.394]	5	43 [1.52]	49 [1.73]	—	20 [0.71]	16 [0.56]	2 [0.07]	2 [0.07]	24 [0.85]	8 [0.28]	8 [0.28]	5	10	15	20	25	30	43 [1.52]	49 [1.73]	
		10	47 [1.66]	53 [1.87]																	
		15	51 [1.80]	57 [2.01]																	
	<b>16</b> [0.630]	5	90 [3.17]	103 [3.63]	—	20 [0.71]	33 [1.16]	4 [0.14]	4 [0.14]	53 [1.87]	17 [0.60]	17 [0.60]	5	10	15	20	25	30	90 [3.17]	103 [3.63]	
		10	97 [3.42]	110 [3.88]																	
		15	104 [3.67]	117 [4.13]																	
	Single acting pull type	<b>6</b> [0.236]	5	27 [0.95]	30 [1.06]	—	20 [0.71]	10 [0.35]	1 [0.04]	1 [0.04]	15 [0.53]	5 [0.18]	5 [0.18]	5	10	15	20	25	30	27 [0.95]	30 [1.06]
			10	30 [1.06]	33 [1.16]																
			15	33 [1.16]	36 [1.27]																
<b>10</b> [0.394]		5	46 [1.62]	52 [1.83]	—	20 [0.71]	16 [0.56]	2 [0.07]	2 [0.07]	24 [0.85]	8 [0.28]	8 [0.28]	5	10	15	20	25	30	46 [1.62]	52 [1.83]	
		10	50 [1.76]	56 [1.98]																	
		15	54 [1.90]	60 [2.12]																	
<b>16</b> [0.630]		5	100 [3.53]	113 [3.99]	—	20 [0.71]	33 [1.16]	4 [0.14]	4 [0.14]	53 [1.87]	17 [0.60]	17 [0.60]	5	10	15	20	25	30	100 [3.53]	113 [3.99]	
		10	107 [3.77]	120 [4.23]																	
		15	114 [4.02]	127 [4.48]																	

Calculation example: To add 2 sensor switches to the cylinder with magnet, double acting type BDAS10 X20,  
 $55 + (20 \times 2) = 95g [3.35oz.]$

Remark: There are 2 types of sensor switch lead wire lengths.

A: 1000mm [39in.], B: 3000mm [118in.]

# Order Codes for Standard Cylinders

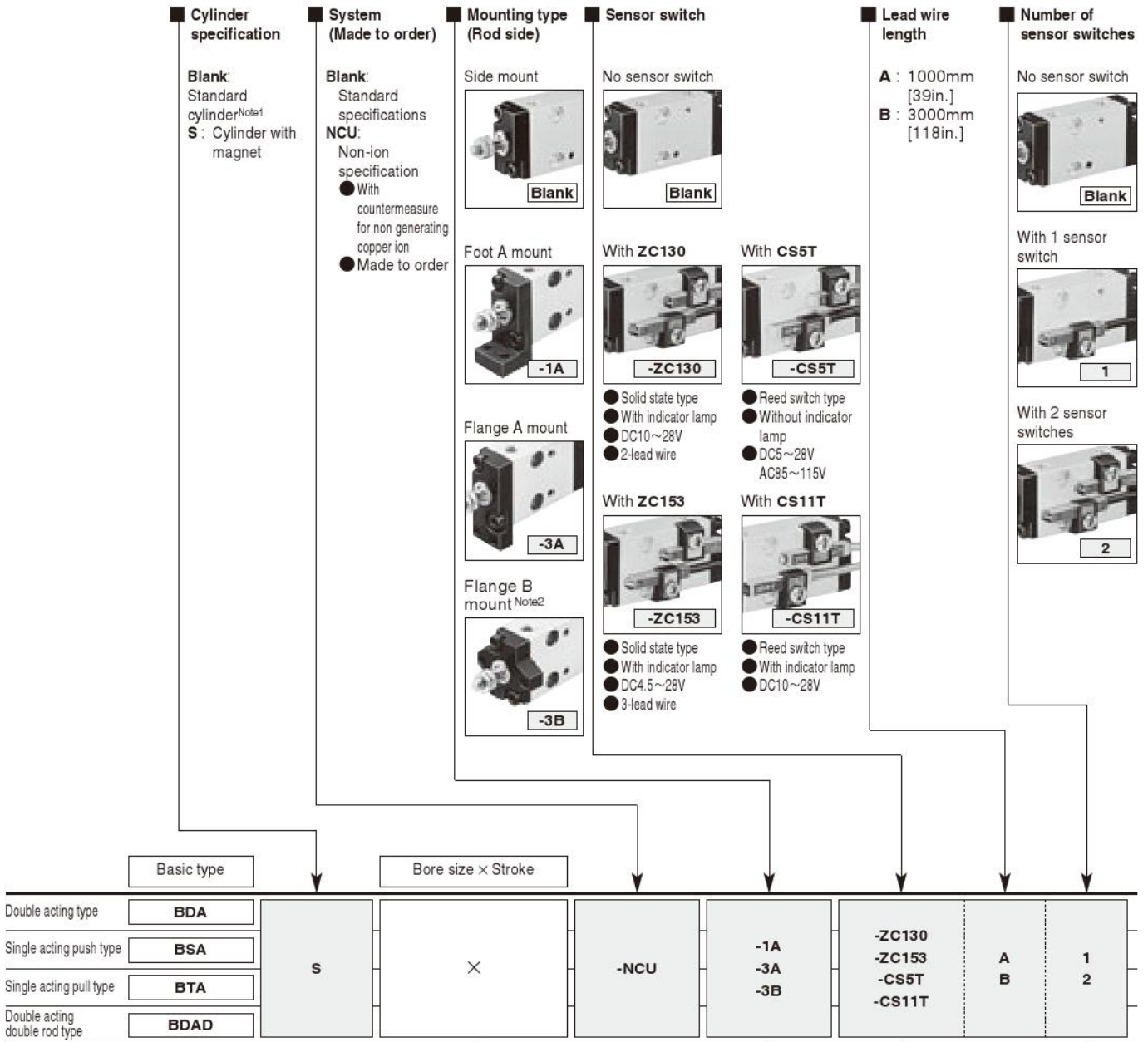

Notes: 1. The magnet for the sensor switch is not built-in. Always use the cylinder with magnet when using the sensor switch.  
 2. Two sensor switches cannot be installed on a cylinder with flange B mount. Mount 1 sensor switch on the head side when the flange B mount is used on the rod side, and mount 1 sensor switch on the rod side when the flange B mount is used on the head side.

Remark: For the cylinder joint and cylinder rod end mounted on the piston rod end, see p.1568.

- See table for operation type, bore size and stroke.
- Order the head side mounting bracket separately. Cannot be ordered as already assembled the mount on the cylinder.
- For the order codes of mounting brackets only, see p.125.

- For the order codes of sensor switches only, see p.126.
- In the 5mm [0.197in.] cylinder strokes, 1 sensor switch installation is standard for CS5T and CS11T. When mounting 2 units, use the solid state type.
- For details, see p.1544.

● In the 5mm [0.197in.] cylinder strokes, 1 sensor switch installation is standard for the reed switch type (CS5T, CS11T).

## Additional Parts (To be ordered separately)

### Mounting brackets



- Side mount (Head cover)
- Foot A mount
- Flange A mount
- Flange B mount
- The photographs above show head side mounting brackets.
- For the order codes, see p.125.
- Comes with 2 mounting screws.

### Shield plate

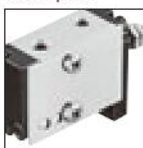

- For cylinder with magnet.
- For the order code, see p.128.
- Comes with 2 mounting screws.

## Operation Type, Bore Size, and Stroke

Operation type	Bore size	Standard strokes	
		mm	
Double acting type	6	5, 10, 15, 20, 25, 30	
	10		
	16		
Single acting push type Single acting pull type	6	5, 10, 15	
	10		
	16		
Double acting double rod type	6	5, 10, 15, 20, 25, 30	
	10		
	16		

## Inner Construction and Major Parts

### ● Double acting type BDA

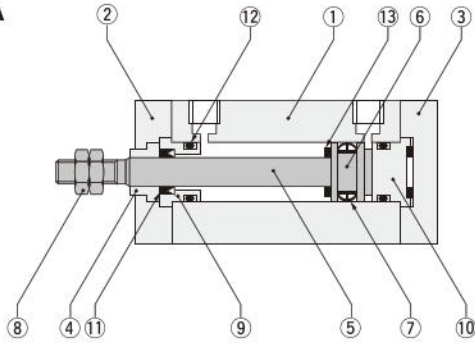

### ● Cylinder with magnet double acting type BDAS

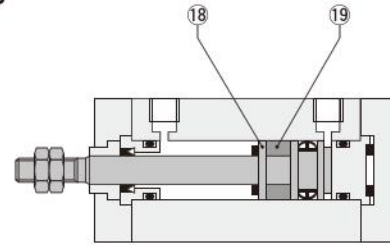

### ● Single acting push type BSA

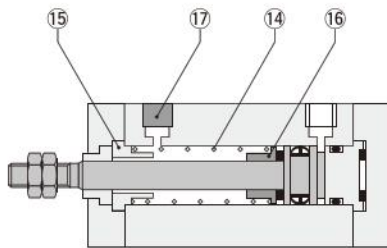

### ● Single acting pull type BTA

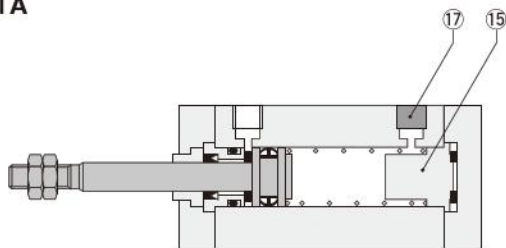

### ● Double acting double rod type BDAD

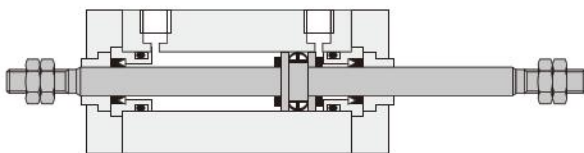

## Major Parts and Materials

No.	Parts	Materials	
		Standard specification	Non-ion specification
①	Body	Aluminum alloy (anodized)	←
②	Rod cover <small>Note</small>	PBT	Aluminum alloy (black anodized)
③	Head cover <small>Note</small>	PBT	Aluminum alloy (black anodized)
④	Rod bushing	Oil impregnated bronze	Special steel
⑤	Piston rod	Stainless steel	←
⑥	Piston	Brass	Aluminum
⑦	Piston seal	Synthetic rubber (NBR)	←
⑧	Rod end nut	Steel (electric nickel plated)	←
⑨	Seal case	Brass	Special steel
⑩	Cap	Polyacetal	←
⑪	Rod seal	Synthetic rubber (NBR)	←
⑫	O-ring	Synthetic rubber (NBR)	←
⑬	Bumper	Synthetic rubber (NBR)	←
⑭	Spring	Steel (zinc plated)	←
⑮	Spring holder	Brass	Aluminum
⑯	Collar	Brass	Aluminum
⑰	Filter	Foamed metal	←
⑱	Support	Brass	Aluminum
⑲	Magnet	φ 6: Sintered alloy magnet φ 10 - φ 16: Plastic magnet	←

Note: Only the foot A mount is steel (black zinc plated).  
Flange A and flange B mounts are aluminum alloy (black anodized).

## Seals

Parts	Rod seal	Piston seal	O-ring
Bore size mm [in.]			
6 [0.236]	NY-6×3×2	COP-6L	8.4×6×1.2
10 [0.394]	NY-8×5×2	COP-10L	10×7.6×1.2
16 [0.630]	NY-9×6×2	COP-16L	16×13×1.5

# Dimensions of Double Acting Type (mm)

● Side mount BDA  Bore size  Stroke

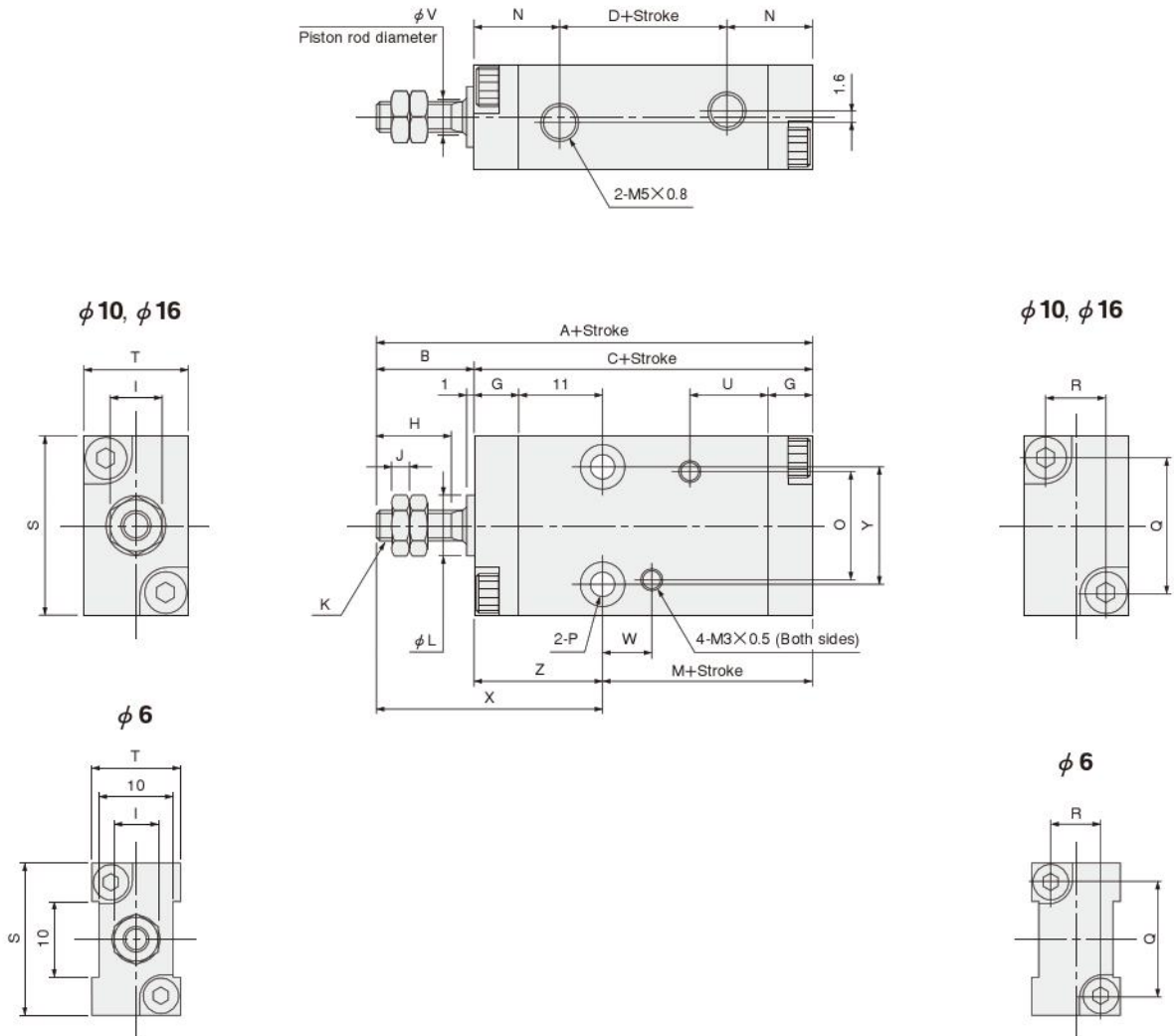

Type Code Bore mm [in.]	Standard cylinder				Cylinder with magnet				B	G	H	I	J	K	L	N	O	P	Q	R	S	T	U	V	W	X	Y	Z
	A	C	D	M	A	C	D	M																				
<b>6 [0.236]</b>	38	28	8	12	43	33	13	17	10	5	7	5.5	1.8	M3×0.5	6 <sup>0</sup> <sub>-0.05</sub>	10	14	$\phi 3.5$ Counterbore $\phi 6$ Depth 4.2 (Both sides)	15	7	20	12		3		26	12	16
<b>10 [0.394]</b>	43	30	7	13	48	35	12	18	13	6	10	7	2.4	M4×0.7	8 <sup>0</sup> <sub>-0.05</sub>	11.5	15	$\phi 3.5$ Counterbore $\phi 6$ Depth 2 (Both sides)	18	8	24	14	10.5	5	6.5	30	16	17
<b>16 [0.630]</b>	48	33	8	15	53	38	13	20	15	7	12	8	3.2	M5×0.8	10 <sup>0</sup> <sub>-0.05</sub>	12.5	19	$\phi 4.5$ Counterbore $\phi 7.6$ Depth 4.2 (Both sides)	25	12	33	20		6	7.5	33	24	18

Note: The 4-M3 × 0.5 female thread (for sensor switch mounting) in the drawing should not be used for mounting the cylinder. Moreover, it is not available in the cylinder body of a standard 5mm [0.197in.] stroke cylinder.

# Dimensions of Double Acting Type (mm)

● Foot A mount BDA  Bore size  ×  Stroke -1A



MULTI MOUNT CYLINDERS

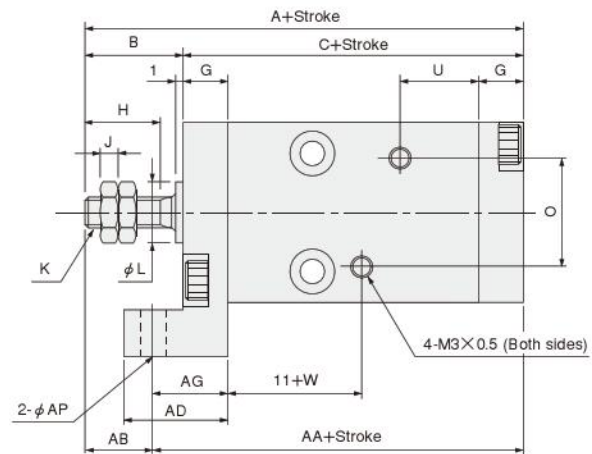
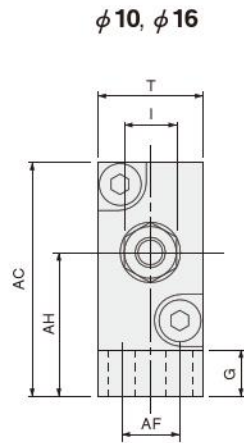
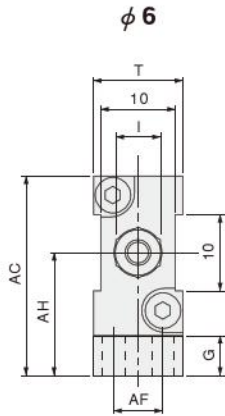
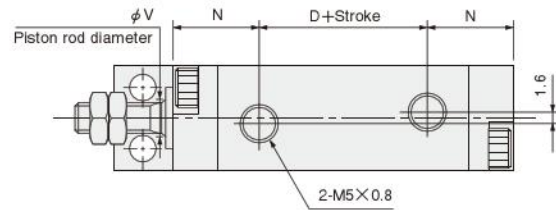

Type Code Bore mm [in.]	Standard cylinder				Cylinder with magnet				B	G	H	I	J	K	L	N	O	T	U	V	W	AB	AC	AD	AF	AG	AH	AP
	A	C	D	AA	A	C	D	AA																				
<b>6 [0.236]</b>	38	28	8	32	43	33	13	37	10	5	7	5.5	1.8	M3×0.5	6 <sup>0</sup> <sub>-0.05</sub>	10	14	12		3		6	26	13	6	9	16	
<b>10 [0.394]</b>	43	30	7	34	48	35	12	39	13	6	10	7	2.4	M4×0.7	8 <sup>0</sup> <sub>-0.05</sub>	11.5	15	14	10.5	5	6.5	9	31	14	8	10	19	3.5
<b>16 [0.630]</b>	48	33	8	38	53	38	13	43	15	7	12	8	3.2	M5×0.8	10 <sup>0</sup> <sub>-0.05</sub>	12.5	19	20		6	7.5	10	41.5	17	12	12	25	4.5

Note: The 4-M3 × 0.5 female thread (for sensor switch mounting) in the drawing should not be used for mounting the cylinder. Moreover, it is not available in the cylinder body of a standard 5mm [0.197in.] stroke cylinder.

# Dimensions of Double Acting Type (mm)

● Flange A mount BDA  Bore size ×  Stroke -3A

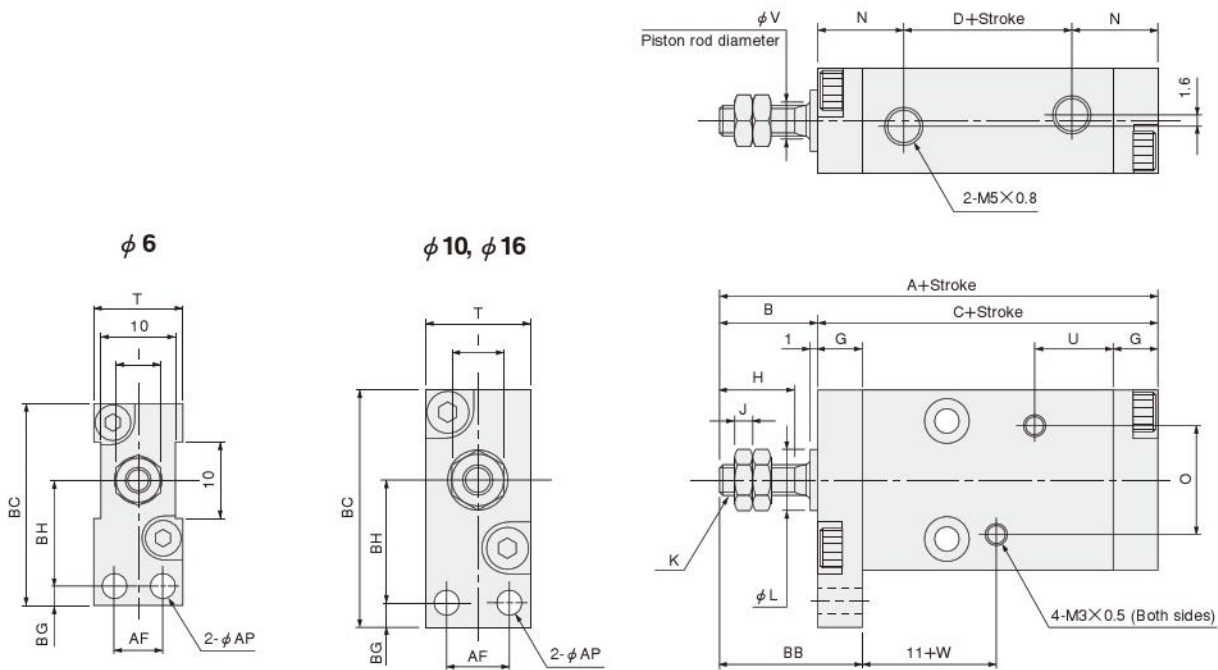

● Flange B mount BDA  Bore size ×  Stroke -3B

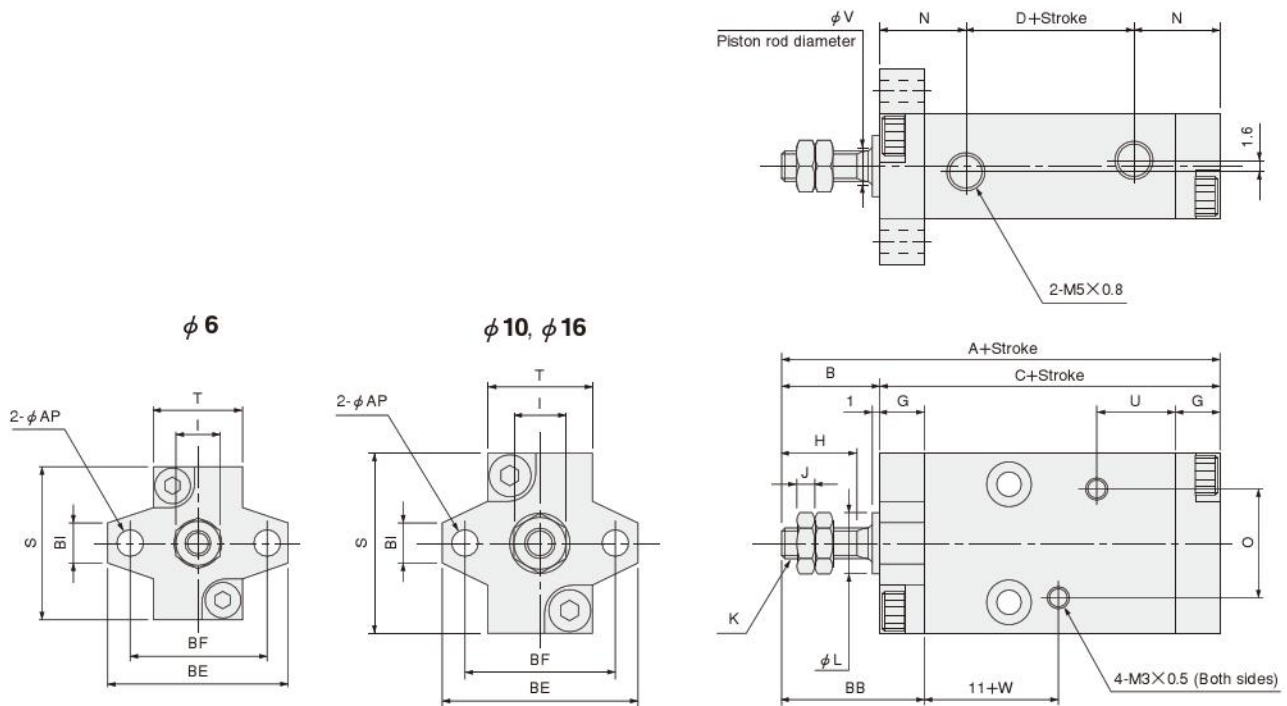

Type Code Bore mm [in.]	Standard cylinder			Cylinder with magnet			B	G	H	I	J	K	L	N	O	S	T	U	V	W	AF	AP	BB	BC	BE	BF	BG	BH	BI
	A	C	D	A	C	D																							
6 [0.236]	38	28	8	43	33	13	10	5	7	5.5	1.8	M3×0.5	6 <sup>0</sup> <sub>-0.05</sub>	10	14	20	12		3	6.5	6	3.5	15	27.5	24	18	3.5	14	
10 [0.394]	43	30	7	48	35	12	13	6	10	7	2.4	M4×0.7	8 <sup>0</sup> <sub>-0.05</sub>	11.5	15	24	14	10.5	5		8		19	31.5	26	20		16	5
16 [0.630]	48	33	8	53	38	13	15	7	12	8	3.2	M5×0.8	10 <sup>0</sup> <sub>-0.05</sub>	12.5	19	33	20		6	7.5	12	4.5	22	42	36	28	4.5	21	6

Note: The 4-M3 × 0.5 female thread (for sensor switch mounting) in the drawing should not be used for mounting the cylinder. Moreover, it is not available in the cylinder body of a standard 5mm [0.197in.] stroke cylinder.

# Dimensions of Single Acting Push Type (mm)

● Side mount BSA  Bore size  × Stroke

 BSA-  Bore size

MULTI MOUNT CYLINDERS

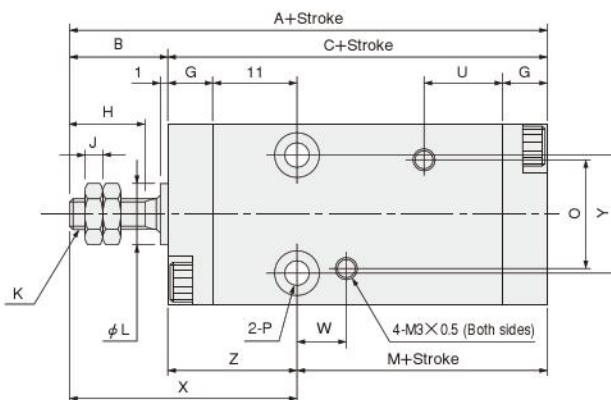
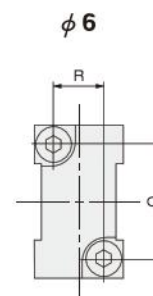
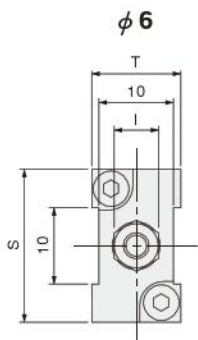
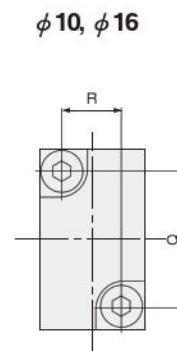
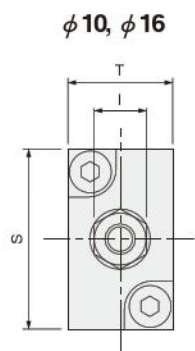
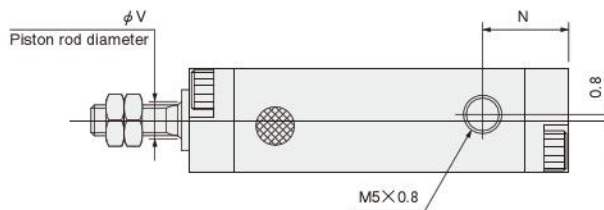

Type Code Bore mm [in.]	Standard cylinder			Cylinder with magnet			B	G	H	I	J	K	L	N	O	P	Q	R	S	T	U	V	W	X	Y	Z
	A	C	M	A	C	M																				
<b>6 [0.236]</b>	43	33	17	48	38	22	10	5	7	5.5	1.8	M3×0.5	6 <sup>0</sup> <sub>-0.05</sub>	10	14	phi 3.5 Counterbore phi 6 Depth4.2 (Both sides)	15	7	20	12		3		26	12	16
<b>10 [0.394]</b>	48	35	18	53	40	23	13	6	10	7	2.4	M4×0.7	8 <sup>0</sup> <sub>-0.05</sub>	11.5	15	phi 3.5 Counterbore phi 6 Depth3.2 (Both sides)	18	8	24	14	10.5	5	6.5	30	16	17
<b>16 [0.630]</b>	53	38	20	58	43	25	15	7	12	8	3.2	M5×0.8	10 <sup>0</sup> <sub>-0.05</sub>	12.5	19	phi 4.5 Counterbore phi 7.6 Depth4.2 (Both sides)	25	12	33	20		6	7.5	33	24	18

Note: The 4-M3 × 0.5 female thread (for sensor switch mounting) in the drawing should not be used for mounting the cylinder. Moreover, it is not available in the cylinder body of a standard 5mm [0.197in.] stroke cylinder.

# Dimensions of Single Acting Push Type (mm)

● Foot A mount BSA □ Bore size × Stroke -1A

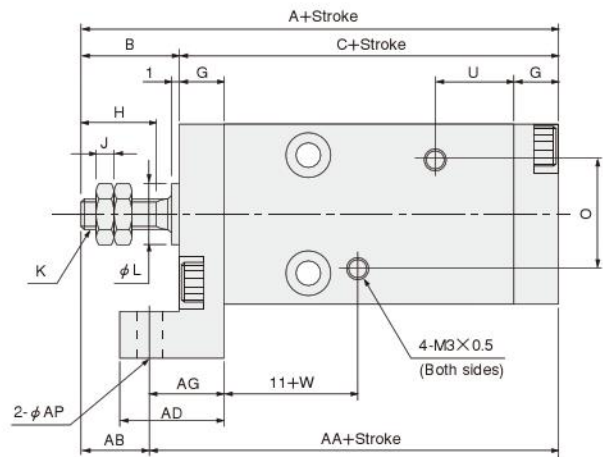
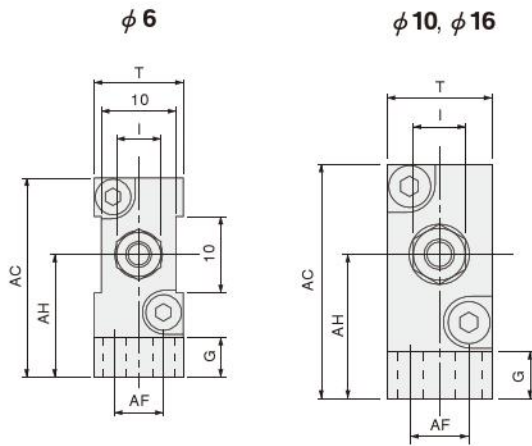
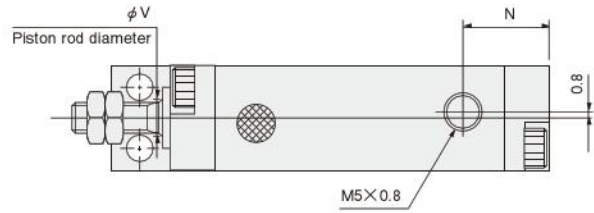

Type Code Bore mm [in.]	Standard cylinder			Cylinder with magnet			B	G	H	I	J	K	L	N	O	T	U	V	W	AB	AC	AD	AF	AG	AH	AP
	A	C	AA	A	C	AA																				
<b>6 [0.236]</b>	43	33	37	48	38	42	10	5	7	5.5	1.8	M3×0.5	6 <sup>0</sup> <sub>-0.05</sub>	10	14	12		3		6	26	13	6	9	16	
<b>10 [0.394]</b>	48	35	39	53	40	44	13	6	10	7	2.4	M4×0.7	8 <sup>0</sup> <sub>-0.05</sub>	11.5	15	14	10.5	5	6.5	9	31	14	8	10	19	3.5
<b>16 [0.630]</b>	53	38	43	58	43	48	15	7	12	8	3.2	M5×0.8	10 <sup>0</sup> <sub>-0.05</sub>	12.5	19	20		6	7.5	10	41.5	17	12	12	25	4.5

Note: The 4-M3 × 0.5 female thread (for sensor switch mounting) in the drawing should not be used for mounting the cylinder. Moreover, it is not available in the cylinder body of a standard 5mm [0.197in.] stroke cylinder.

# Dimensions of Single Acting Push Type (mm)

● Flange A mount BSA  Bore size  ×  Stroke -3A

CAD BSA-  Bore size   
MULTI-3A

MULTI MOUNT CYLINDERS

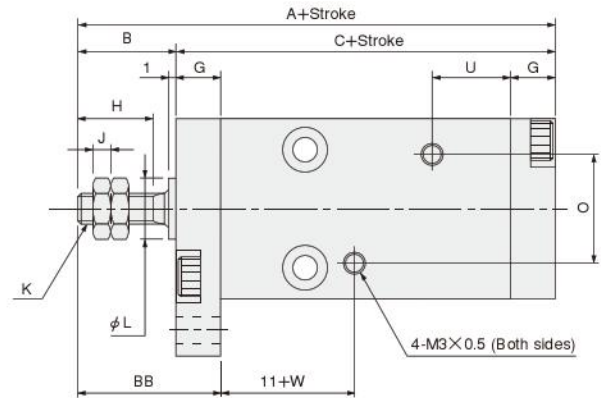
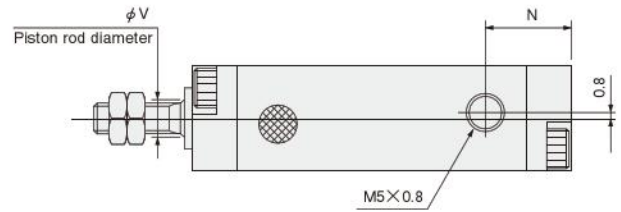
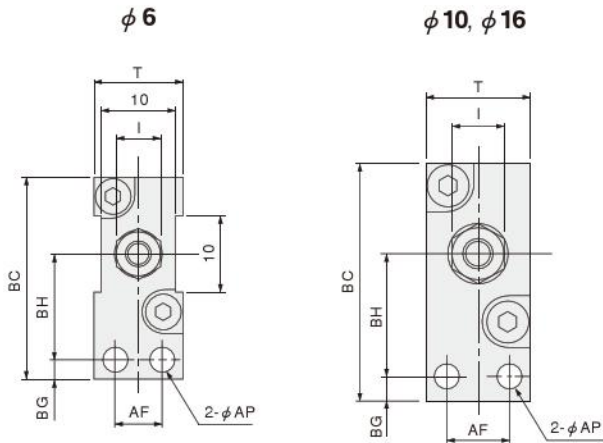

● Flange B mount BSA  Bore size  ×  Stroke -3B

CAD BSA-  Bore size   
MULTI-3B

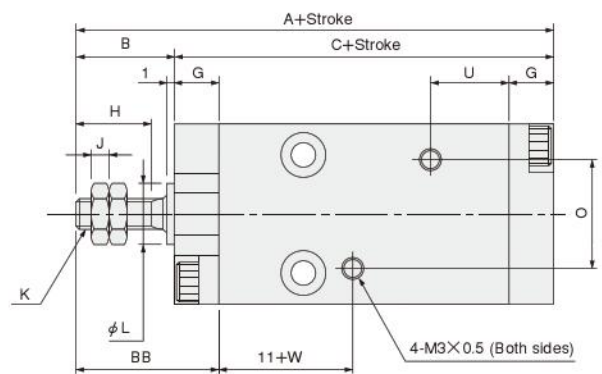
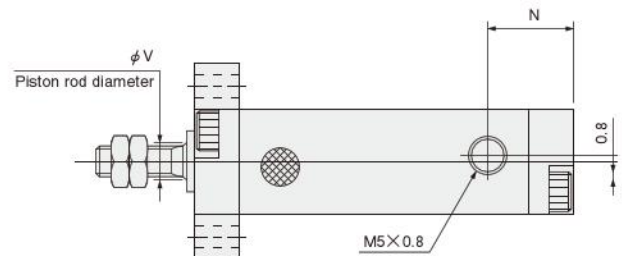
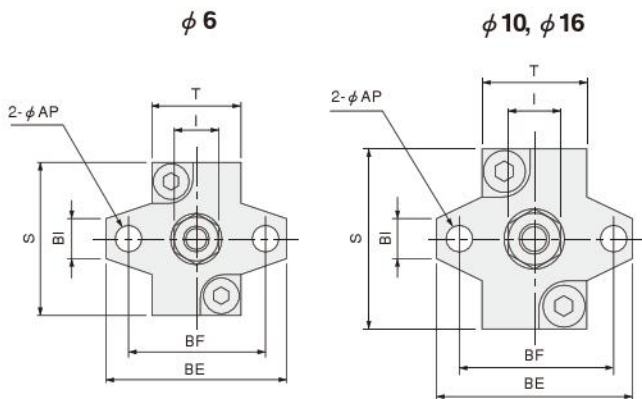

Type	Standard cylinder		Cylinder with magnet		B	G	H	I	J	K	L	N	O	S	T	U	V	W	AF	AP	BB	BC	BE	BF	BG	BH	BI
	Code	A	C	A																							
6 [0.236]	43	33	48	38	10	5	7	5.5	1.8	M3×0.5	6 <sup>0</sup> <sub>-0.05</sub>	10	14	20	12	3	6.5	6	3.5	15	27.5	24	18	3.5	14	5	
10 [0.394]	48	35	53	40	13	6	10	7	2.4	M4×0.7	8 <sup>0</sup> <sub>-0.05</sub>	11.5	15	24	14	10.5	5	8	19	31.5	26	20	20	16	5		
16 [0.630]	53	38	58	43	15	7	12	8	3.2	M5×0.8	10 <sup>0</sup> <sub>-0.05</sub>	12.5	19	33	20	6	7.5	12	4.5	22	42	36	28	4.5	21	6	

Note: The 4-M3 × 0.5 female thread (for sensor switch mounting) in the drawing should not be used for mounting the cylinder. Moreover, it is not available in the cylinder body of a standard 5mm [0.197in.] stroke cylinder.

# Dimensions of Single Acting Pull Type (mm)

● Side mount BTA  Bore size  Stroke

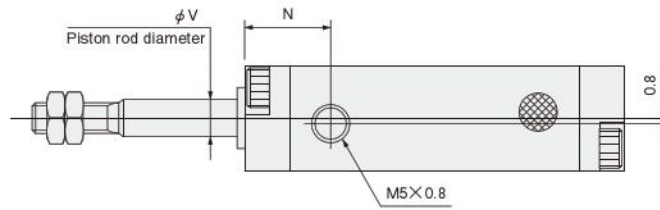

φ 10, φ 16

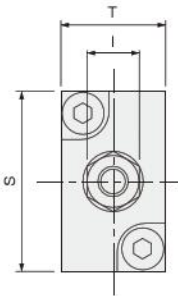

φ 6

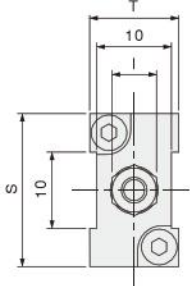

φ 10, φ 16

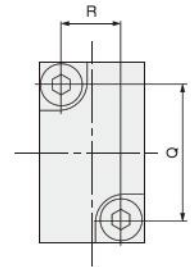

φ 6

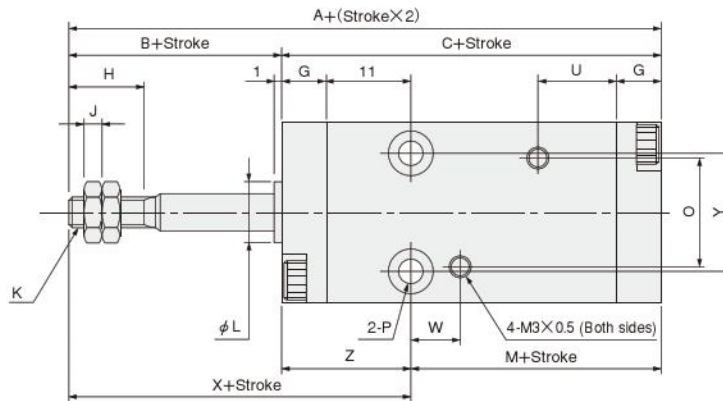
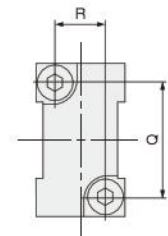

Type	Standard cylinder			Cylinder with magnet			B	G	H	I	J	K	L	N	O	P				Q	R	S	T	U	V	W	X	Y	Z
Code	A	C	M	A	C	M																							
<b>6 [0.236]</b>	43	33	17	48	38	22	10	5	7	5.5	1.8	M3×0.5	6 <sup>0</sup> <sub>-0.05</sub>	10	14	φ 3.5 Counterbore φ 6 Depth4.2 (Both sides)				15	7	20	12		3		26	12	16
<b>10 [0.394]</b>	48	35	18	53	40	23	13	6	10	7	2.4	M4×0.7	8 <sup>0</sup> <sub>-0.05</sub>	11.5	15	φ 3.5 Counterbore φ 6 Depth3.2 (Both sides)				18	8	24	14	10.5	5		30	16	17
<b>16 [0.630]</b>	53	38	20	58	43	25	15	7	12	8	3.2	M5×0.8	10 <sup>0</sup> <sub>-0.05</sub>	12.5	19	φ 4.5 Counterbore φ 7.6 Depth4.2 (Both sides)				25	12	33	20		6	7.5	33	24	18

Note: The 4-M3 × 0.5 female thread (for sensor switch mounting) in the drawing should not be used for mounting the cylinder. Moreover, it is not available in the cylinder body of a standard 5mm [0.197in.] stroke cylinder.

# Dimensions of Single Acting Pull Type (mm)

● Foot A mount BTA  Bore size  ×  Stroke -1A



MULTI MOUNT CYLINDERS

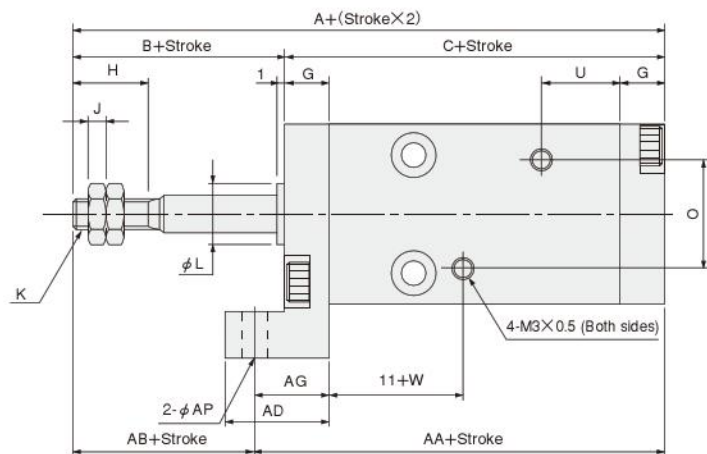
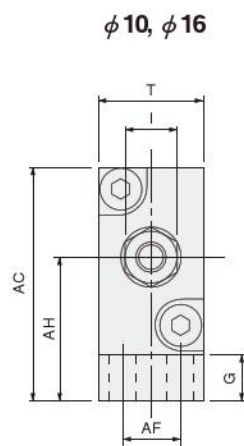
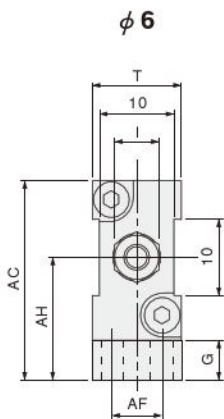
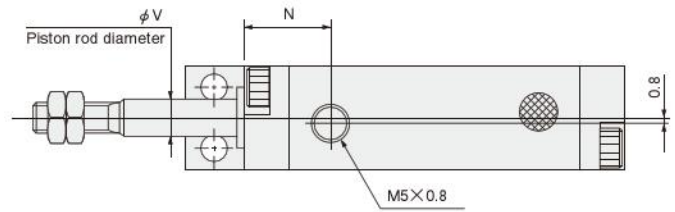

Type Code Bore mm [in.]	Standard cylinder			Cylinder with magnet			B	G	H	I	J	K	L	N	O	T	U	V	W	AB	AC	AD	AF	AG	AH	AP
	A	C	AA	A	C	AA																				
<b>6 [0.236]</b>	43	33	37	48	38	42	10	5	7	5.5	1.8	M3×0.5	6 <sup>0</sup> <sub>-0.05</sub>	10	14	12	10.5	3	6.5	6	26	13	6	9	16	3.5
<b>10 [0.394]</b>	48	35	39	53	40	44	13	6	10	7	2.4	M4×0.7	8 <sup>0</sup> <sub>-0.05</sub>	11.5	15	14		5		9	31	14	8	10	19	
<b>16 [0.630]</b>	53	38	43	58	43	48	15	7	12	8	3.2	M5×0.8	10 <sup>0</sup> <sub>-0.05</sub>	12.5	19	20	6	7.5	10	41.5	17	12	12	25	4.5	

Note: The 4-M3 × 0.5 female thread (for sensor switch mounting) in the drawing should not be used for mounting the cylinder. Moreover, it is not available in the cylinder body of a standard 5mm [0.197in.] stroke cylinder.

# Dimensions of Single Acting Pull Type (mm)

● Flange A mount BTA  Bore size  ×  Stroke -3A

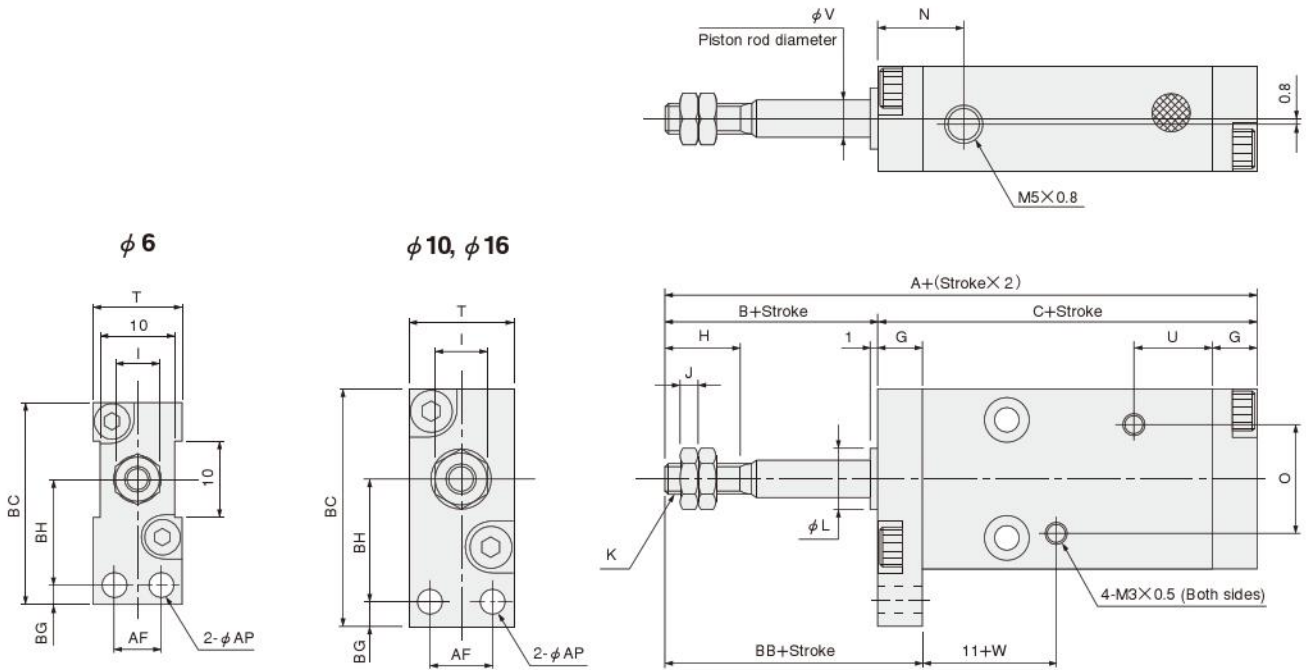

● Flange B mount BTA  Bore size  ×  Stroke -3B

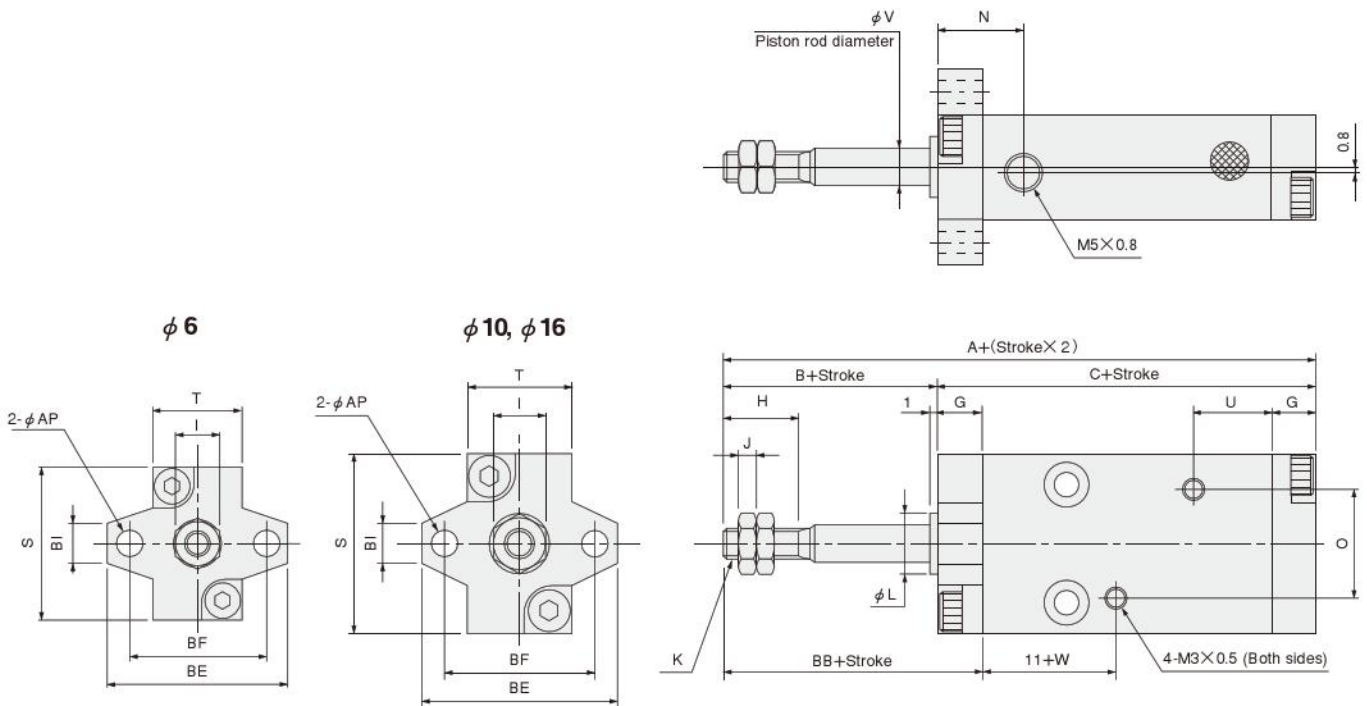

Type	Standard cylinder		Cylinder with magnet		B	G	H	I	J	K	L	N	O	S	T	U	V	W	AF	AP	BB	BC	BE	BF	BG	BH	BI
	Code	A	C	A																							
6 [0.236]	43	33	48	38	10	5	7	5.5	1.8	M3×0.5	6 <sup>0</sup> <sub>-0.05</sub>	10	14	20	12	10.5	3	6.5	6	3.5	15	27.5	24	18	3.5	14	5
10 [0.394]	48	35	53	40	13	6	10	7	2.4	M4×0.7	8 <sup>0</sup> <sub>-0.05</sub>	11.5	15	24	14		5		8		19	31.5	26	20		16	
16 [0.630]	53	38	58	43	15	7	12	8	3.2	M5×0.8	10 <sup>0</sup> <sub>-0.05</sub>	12.5	19	33	20	6	7.5	12	4.5	22	42	36	28	4.5	21	6	

Note: The 4-M3 × 0.5 female thread (for sensor switch mounting) in the drawing should not be used for mounting the cylinder. Moreover, it is not available in the cylinder body of a standard 5mm [0.197in.] stroke cylinder.

# Dimensions of Double Acting Double Rod Type (mm)

● Side mount BDAD  Bore size  Stroke

CAD BDAD- Bore size

MULTI MOUNT CYLINDERS

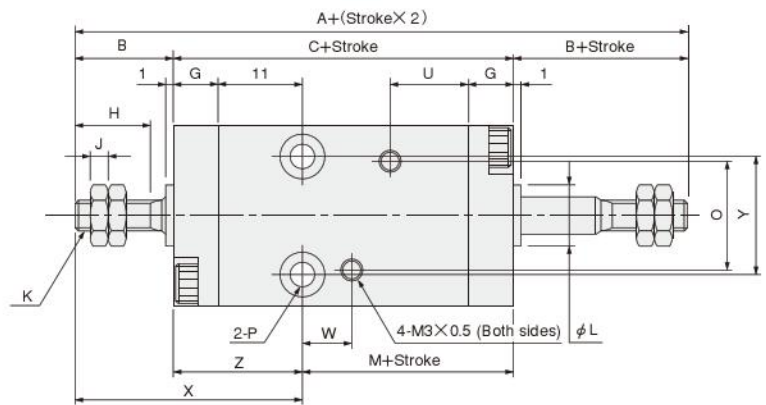
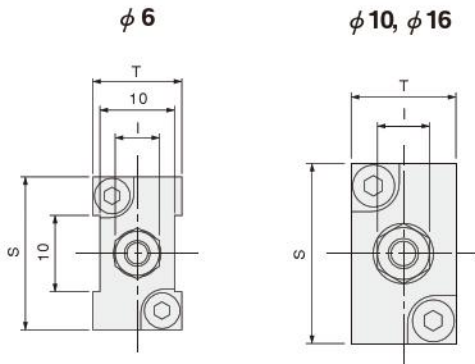
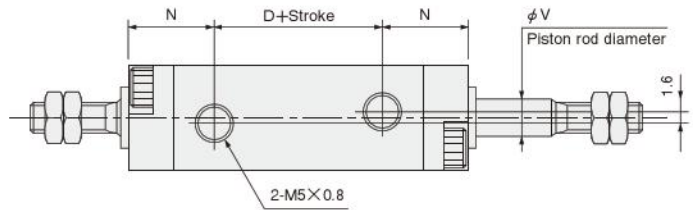

Type	Standard cylinder				Cylinder with magnet																								
Code	A	C	D	M	A	C	D	M	B	G	H	I	J	K	L	N	O	P				S	T	U	V	W	X	Y	Z
Bore mm [in.]																													
<b>6 [0.236]</b>	48	28	8	12	53	33	13	17	10	5	7	5.5	1.8	M3 x 0.5	6 <sup>0</sup> <sub>-0.05</sub>	10	14	phi 3.5 Counterbore phi 6 Depth 4.2 (Both sides)				20	12		3		26	12	16
<b>10 [0.394]</b>	56	30	7	13	61	35	12	18	13	6	10	7	2.4	M4 x 0.7	8 <sup>0</sup> <sub>-0.05</sub>	11.5	15	phi 3.5 Counterbore phi 6 Depth 3.2 (Both sides)				24	14	10.5	5	6.5	30	16	17
<b>16 [0.630]</b>	63	33	8	15	68	38	13	20	15	7	12	8	3.2	M5 x 0.8	10 <sup>0</sup> <sub>-0.05</sub>	12.5	19	phi 4.5 Counterbore phi 7.6 Depth 4.2 (Both sides)				33	20		6	7.5	33	24	18

Note: The 4-M3 x 0.5 female thread (for sensor switch mounting) in the drawing should not be used for mounting the cylinder. Moreover, it is not available in the cylinder body of a standard 5mm [0.197in.] stroke cylinder.

# Dimensions of Double Acting Double Rod Type (mm)

● Foot A mount BDAD  Bore size  × Stroke -1A

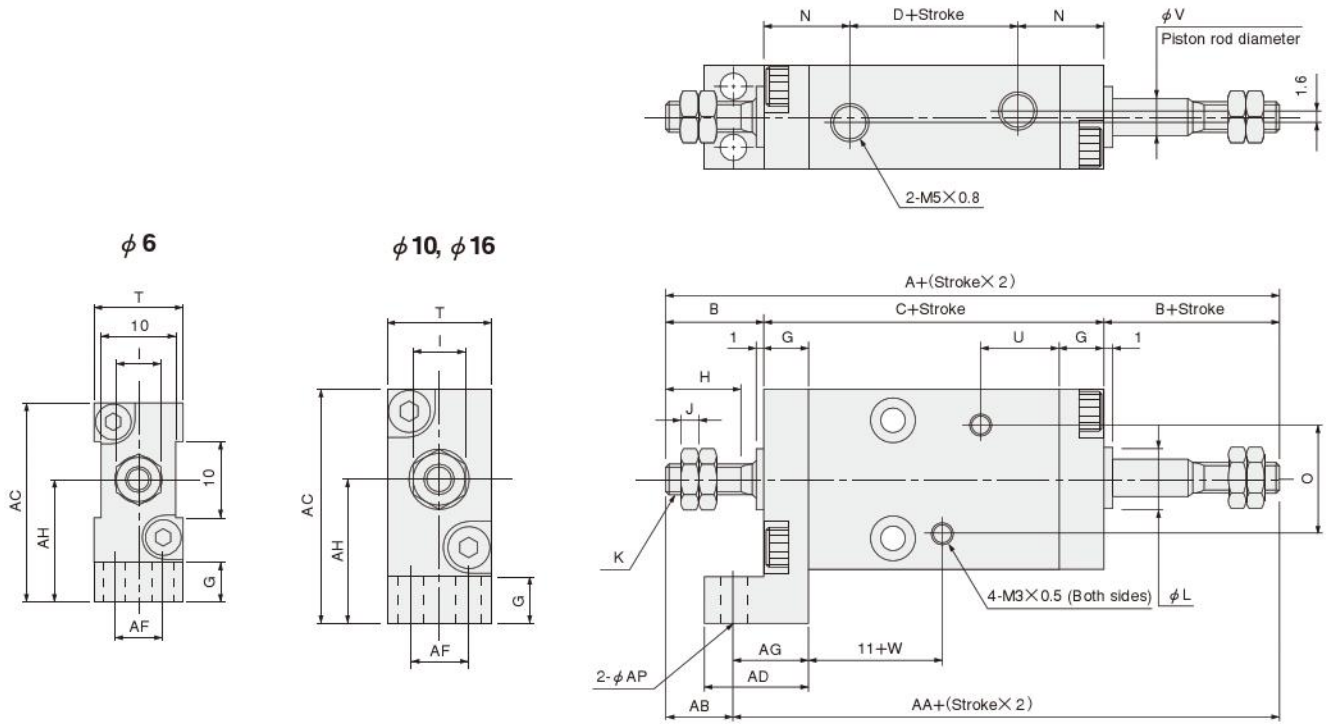

Type Code Bore mm [in.]	Standard cylinder				Cylinder with magnet				B	G	H	I	J	K	L	N	O	T	U	V	W	AB	AC	AD	AF	AG	AH	AP
	A	C	D	AA	A	C	D	AA																				
<b>6 [0.236]</b>	48	28	8	42	53	33	13	47	10	5	7	5.5	1.8	M3×0.5	6 <sup>0</sup> <sub>-0.05</sub>	10	14	12		3		6	26	13	6	9	16	
<b>10 [0.394]</b>	56	30	7	47	61	35	12	52	13	6	10	7	2.4	M4×0.7	8 <sup>0</sup> <sub>-0.05</sub>	11.5	15	14	10.5	5	6.5	9	31	14	8	10	19	3.5
<b>16 [0.630]</b>	63	33	8	53	68	38	13	58	15	7	12	8	3.2	M5×0.8	10 <sup>0</sup> <sub>-0.05</sub>	12.5	19	20		6	7.5	10	41.5	17	12	12	25	4.5

Note: The 4-M3 × 0.5 female thread (for sensor switch mounting) in the drawing should not be used for mounting the cylinder. Moreover, it is not available in the cylinder body of a standard 5mm [0.197in.] stroke cylinder.

# Dimensions of Double Acting Double Rod Type (mm)

● Flange A mount BDAD  Bore size  × Stroke  -3A



MULTI MOUNT CYLINDERS

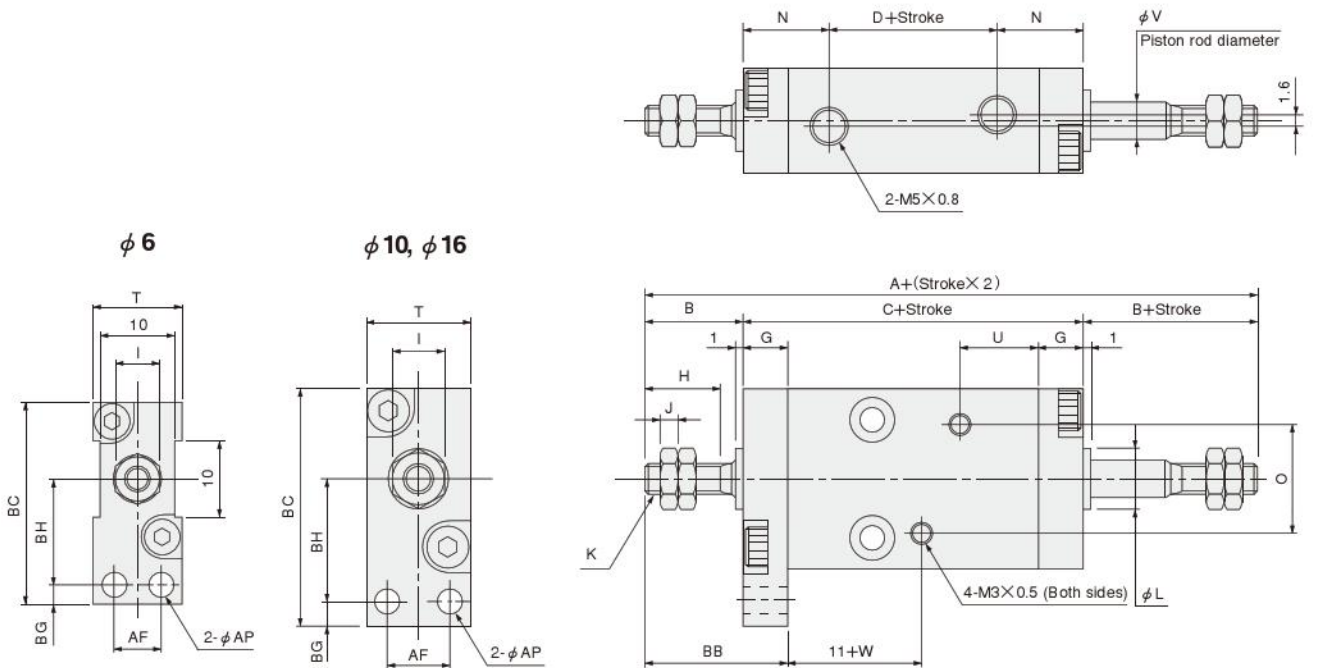

● Flange B mount BDAD  Bore size  × Stroke  -3B

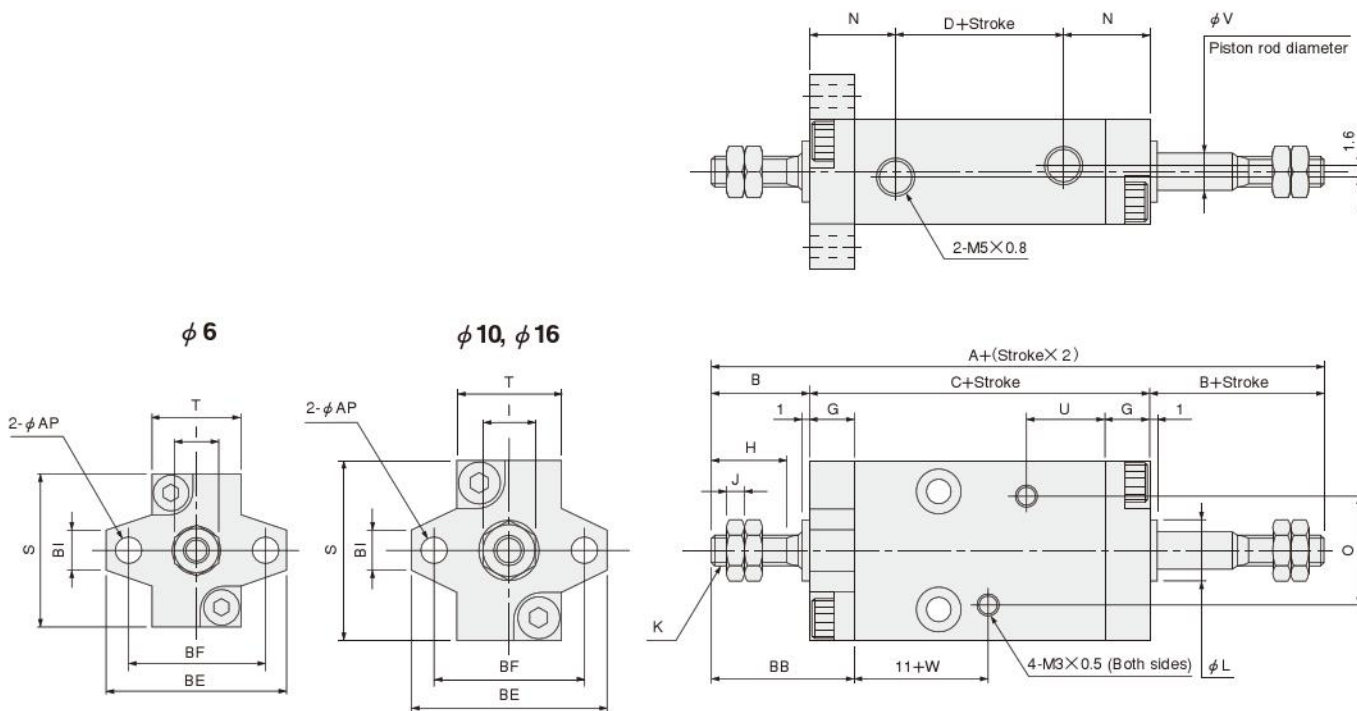

Type	Standard cylinder		Cylinder with magnet			B	G	H	I	J	K	L	N	O	S	T	U	V	W	AF	AP	BB	BC	BE	BF	BG	BH	BI
	Code	A	C	D	A																							
6 [0.236]	48	28	8	53	33	13	10	5	7	5.5	1.8	M3×0.5	6 <sup>0</sup> <sub>-0.05</sub>	10	14	20	12	3	6.5	6	3.5	15	27.5	24	18	3.5	14	
10 [0.394]	56	30	7	61	35	12	13	6	10	7	2.4	M4×0.7	8 <sup>0</sup> <sub>-0.05</sub>	11.5	15	24	14	10.5	5	8	8	19	31.5	26	20	20	16	5
16 [0.630]	63	33	8	68	38	13	15	7	12	8	3.2	M5×0.8	10 <sup>0</sup> <sub>-0.05</sub>	12.5	19	33	20	6	7.5	12	4.5	22	42	36	28	4.5	21	6

Note: The 4-M3 × 0.5 female thread (for sensor switch mounting) in the drawing should not be used for mounting the cylinder. Moreover, it is not available in the cylinder body of a standard 5mm [0.197in.] stroke cylinder.

# MOUNTING BRACKETS

Rod Side Mounting Bracket,  
Head Side Mounting Bracket

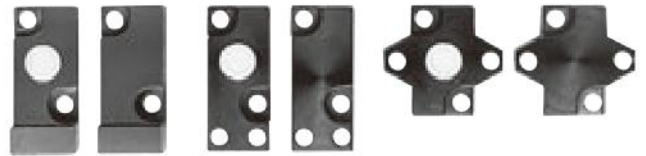

## Mounting Bracket Model (Order Codes)

Mounting location	Cylinder model	Bore size mm [in.]	Mounting brackets			
			Side mount	Foot A mount	Flange A mount	Flange B mount
Rod side	BDA □	6 [0.236]	DB60A	DB61A	DB63A	DB63B
	BSA □	10 [0.394]	D100A	D101A	D103A	D103B
	BTA □	16 [0.630]	D160A	D161A	D163A	D163B
	BDAD □	16 [0.630]	D160A	D161A	D163A	D163B
Head side	BDAL □	6 [0.236]	LB60A	—	LB63A	LB63B
	BSAL □	10 [0.394]	L100A	—	L103A	L103B
	BTAL □	16 [0.630]	L160A	—	L163A	L163B
	BDADL □	16 [0.630]	L160A	—	L163A	L163B
All types except double rod type	6 [0.236]	BB60A	BB61A	BB63A	BB63B	
	10 [0.394]	B100A	B101A	B103A	B103B	
	16 [0.630]	B160A	B161A	B163A	B163B	

- Remarks: 1. All mounting brackets come with 2 mounting screws.  
 2. Order separately for all head side mounting brackets.  
 3. For the order codes of rod side mounting brackets assembled with cylinders, see p.99 and 115.  
 4. No rod side foot A mount for the non-rotating cylinder is available. For non-rotating double rod cylinders, however, a separately ordered foot A mount can be installed on the rod side opposite the non-rotation plate.  
 5. A rod bushing is assembled into the rod side mounting bracket.

### How to read the codes

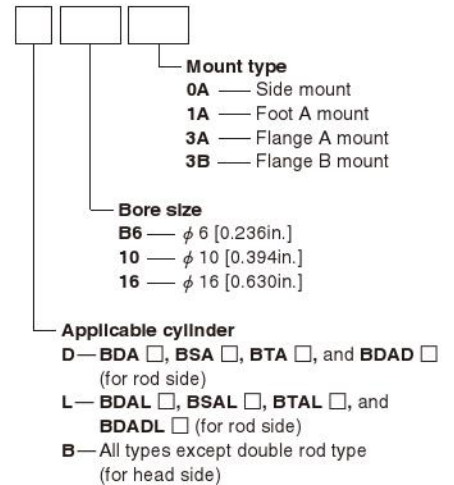

## Dimensions of Head Side Mounting Bracket (mm)

### Foot A mount: -1A

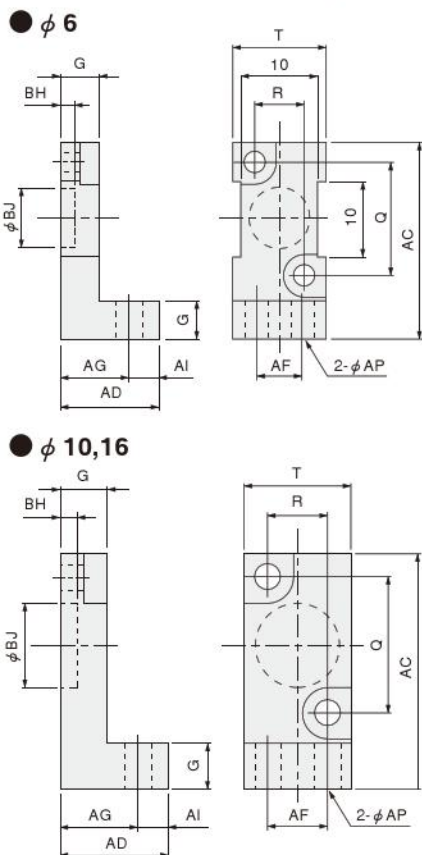

### Flange A mount: -3A

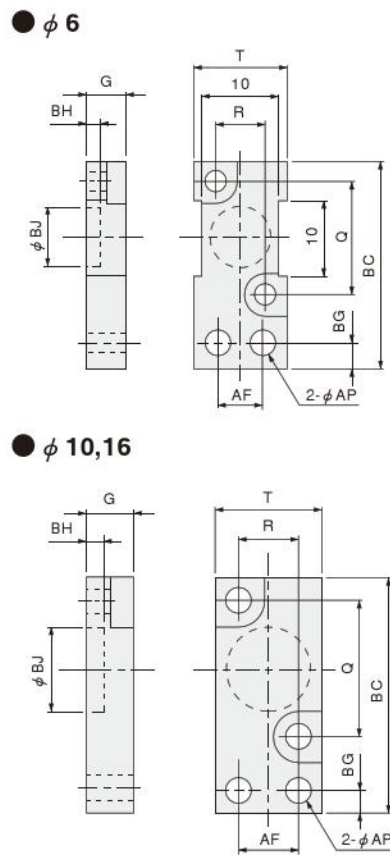

### Flange B mount: -3B

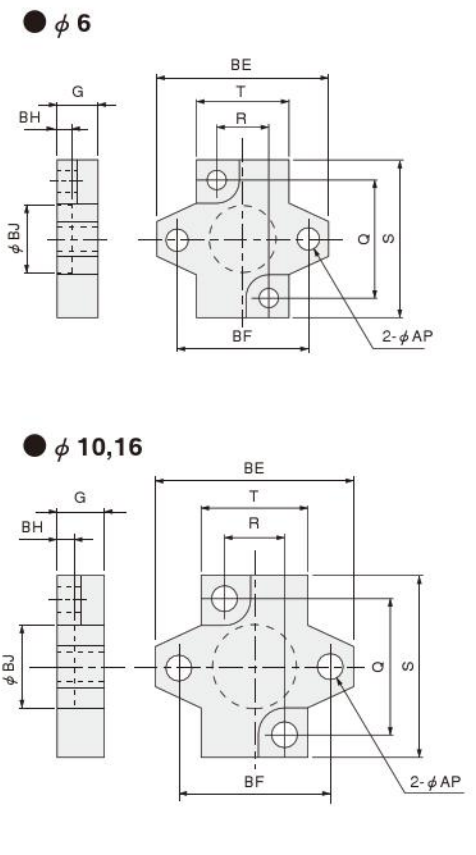

Bore size mm [in.]	Code	G	Q	R	S	T	AC	AD	AF	AG	AI	AP	BC	BE	BF	BG	BH	BJ
6 [0.236]		5	15	7	20	12	26	13	6	9	4	3.5	27.5	24	18	3.5	2 <sup>+0.05</sup> <sub>0</sub>	8 <sup>+0.1</sup> <sub>0</sub>
10 [0.394]		6	18	8	24	14	31	14	8	10	4	3.5	31.5	26	20	3.5	2 <sup>+0.05</sup> <sub>0</sub>	12 <sup>+0.1</sup> <sub>0</sub>
16 [0.630]		7	25	12	33	20	41.5	17	12	12	5	4.5	42	36	28	4.5	2 <sup>+0.05</sup> <sub>0</sub>	18 <sup>+0.1</sup> <sub>0</sub>

Remark: For the side mount (head cover), see the cylinder dimensions.

# SENSOR SWITCHES

Solid State Type, Reed Switch Type

MULTI MOUNT CYLINDERS



## Order Codes (for Sensor Switches Only)

		Sensor switches	Option	Lead wire length	With sensor holder
Solid state type with indicator lamp	DC10~28V	ZC130	A B		-BDAS6 -BDAS10 -BDAS16
Solid state type with indicator lamp	DC4.5~28V	ZC153			
Reed switch type without indicator lamp	DC5~28V	CS5T			
Reed switch type with indicator lamp	AC85~115V	CS11T			

- A : 1000mm [39in.]
- B : 3000mm [118in.]

★ Order codes of sensor holders only

- For  $\phi$  6 cylinder — C1-BDAS6      ● -BDAS6 : For  $\phi$  6 cylinder
- For  $\phi$  10 cylinder — C1-BDAS10      ● -BDAS10 : For  $\phi$  10 cylinder
- For  $\phi$  16 cylinder — C1-BDAS16      ● -BDAS16 : For  $\phi$  16 cylinder

● For sensor switch details, see p.1544.

## Moving Sensor Switch

- Loosening mounting screw allows the sensor switch to be moved freely in the cylinder's axial direction.
- Tighten the mounting screw with a tightening torque of 19.6N·cm [1.73in·lbf] or less.

●  $\phi$  6

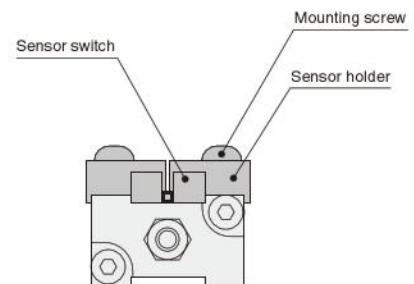

●  $\phi$  10,16

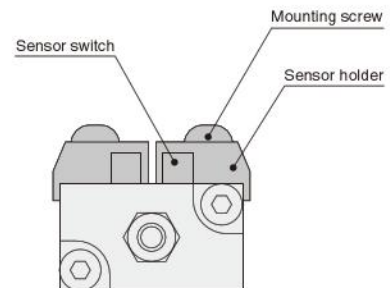

## Minimum Cylinder Strokes When Using Sensor Switches

Bore size	mm [in.]			
	Solid state type sensor switch		Reed switch type sensor switch	
	Mounting 2 pcs.	Mounting 1 pc.	Mounting 2 pcs.	Mounting 1 pc.
6 [0.236]				
10 [0.394]	5	5	10	5
16 [0.630]				

Remark: Two sensor switches cannot be mounted on a cylinder with flange B mount.

Mount 1 sensor switch on the head side when the flange B mount is used on the rod side, and mount 1 sensor switch on the rod side when the flange B mount is used on the head side.

# Sensor Switch Operating Range, Response Differential, and Maximum Sensing Location

- **Operating range:  $\ell$**   
The distance the piston travels in one direction, while the switch is in the ON position.
- **Response differential: C**  
The distance between the point where the piston turns the switch ON, and the point where the switch is turned OFF as the piston travels in the opposite direction.

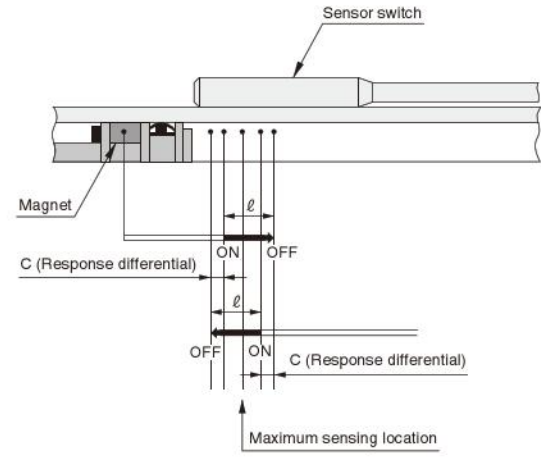

Bore size	ZC130□, ZC153□		CS5T□, CS11T□	
	Operating range	Response differential	Operating range	Response differential
6 [0.236]	2.0~3.0 [0.079~0.118]	0.3 [0.012] or less	4.8~7.2 [0.189~0.283]	1.3 [0.051] or less
10 [0.394]	2.0~3.0 [0.079~0.118]	0.3 [0.012] or less	5.8~8.3 [0.228~0.327]	2.0 [0.079] or less
16 [0.630]	2.5~4.0 [0.098~0.157]	0.3 [0.012] or less	7.5~9.4 [0.295~0.370]	2.5 [0.098] or less

Remark: The above table shows reference values.

## Mounting Location of End of Stroke Detection Sensor Switch

- **Cylinder with magnet**
- **Double rod cylinder with magnet**

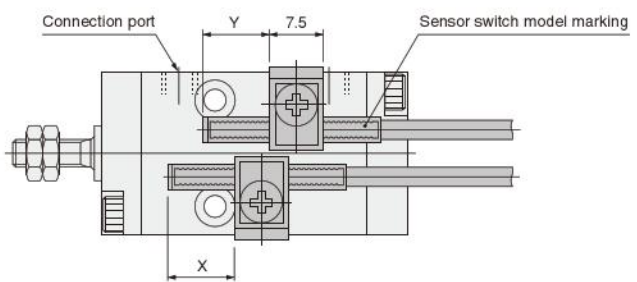

- **Non-rotating cylinder with magnet**
- **Non-rotating double rod cylinder**

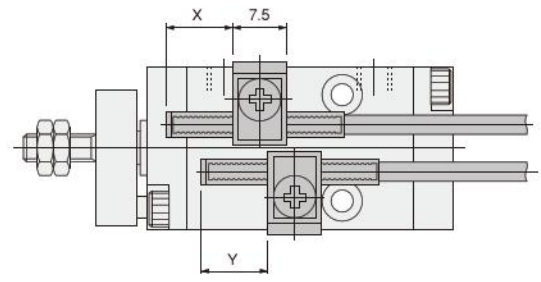

### Double acting type (Including double rod cylinders)

Bore size	Mounting location	Sensor switch model		
		ZC130□, ZC153□	CS5T□	CS11T□
6 [0.236]	X	13.0 [0.512]	11.5 [0.453]	15 [0.591]
10 [0.394]	Y	8.0 [0.315]	6.5 [0.256]	10 [0.394]
16 [0.630]	X	14.0 [0.551]	12.5 [0.492]	16 [0.630]
	Y	9.0 [0.354]	7.5 [0.295]	11 [0.433]

### Double acting type (Including double rod cylinders)

Bore size	Mounting location	Sensor switch model		
		ZC130□, ZC153□	CS5T□	CS11T□
6 [0.236]	X	6.0 [0.236]	4.5 [0.177]	8 [0.315]
10 [0.394]	Y	1.0 [0.039]	-0.5 [-0.020]	3 [0.118]
16 [0.630]	X	7.0 [0.276]	5.5 [0.217]	9 [0.354]
	Y	2.0 [0.079]	0.5 [0.020]	4 [0.157]

### Single acting push type

Bore size	Mounting location	Sensor switch model		
		ZC130□, ZC153□	CS5T□	CS11T□
6 [0.236]	X	8.0 [0.315]	6.5 [0.256]	10 [0.394]
10 [0.394]	Y	8.0 [0.315]	6.5 [0.256]	10 [0.394]
16 [0.630]	X	9.0 [0.354]	7.5 [0.295]	11 [0.433]
	Y	9.0 [0.354]	7.5 [0.295]	11 [0.433]

### Single acting push type

Bore size	Mounting location	Sensor switch model		
		ZC130□, ZC153□	CS5T□	CS11T□
6 [0.236]	X	1.0 [0.039]	-0.5 [-0.020]	3 [0.118]
10 [0.394]	Y	1.0 [0.039]	-0.5 [-0.020]	3 [0.118]
16 [0.630]	X	2.0 [0.079]	0.5 [0.020]	4 [0.157]
	Y	2.0 [0.079]	0.5 [0.020]	4 [0.157]

### Single acting pull type

Bore size	Mounting location	Sensor switch model		
		ZC130□, ZC153□	CS5T□	CS11T□
6 [0.236]	X	13.0 [0.512]	11.5 [0.453]	15 [0.591]
10 [0.394]	Y	13.0 [0.512]	11.5 [0.453]	15 [0.591]
16 [0.630]	X	14.0 [0.551]	12.5 [0.492]	16 [0.630]
	Y	14.0 [0.551]	12.5 [0.492]	16 [0.630]

### Single acting pull type

Bore size	Mounting location	Sensor switch model		
		ZC130□, ZC153□	CS5T□	CS11T□
6 [0.236]	X	6.0 [0.236]	11.5 [0.453]	8 [0.315]
10 [0.394]	Y	6.0 [0.236]	11.5 [0.453]	8 [0.315]
16 [0.630]	X	7.0 [0.276]	12.5 [0.492]	9 [0.354]
	Y	7.0 [0.276]	12.5 [0.492]	9 [0.354]

- Remarks:
- The above tables give reference values for the standard strokes. For the procedure to find-out the best position, see p. 129.
  - The above figures show the piping connection port when it has been turned to face upward.
  - Use the distance between the cylinder mounting hole and the rod cover to confirm the mounting location of the double rod cylinder's end of stroke detection sensor switch.
  - Mount the sensor switch so that the surface showing the sensor switch model faces up.

●  $\phi 6$

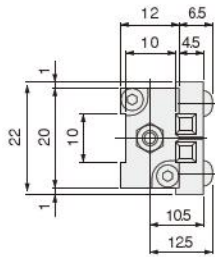

●  $\phi 10$

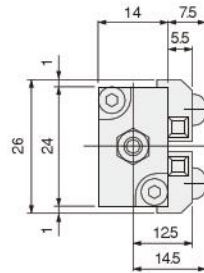

●  $\phi 16$

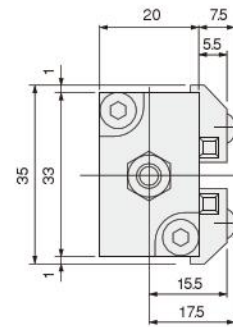

### Precautions for Mounting Cylinders with Magnet

When mounting 2 or more Multi Mount Cylinders with sensor switches in close proximity, use the conditions shown to the right.

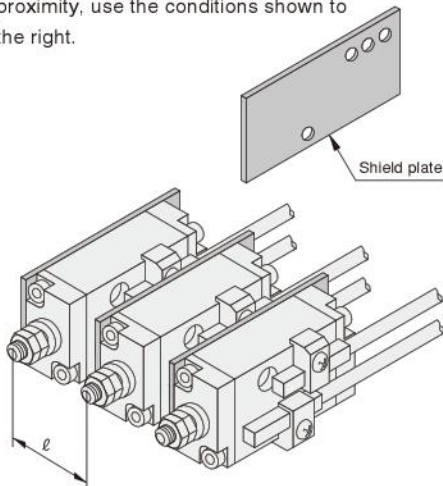

Bore size mm [in.]	Without shield plate		With shield plate
	$l$	$l$	$l$
<b>6 [0.236]</b>	25mm [0.984] or longer	23mm [0.906] or longer	22mm [0.866] or longer
<b>10 [0.394]</b>	29mm [1.142] or longer	31mm [1.220] or longer	25mm [0.984] or longer
<b>16 [0.630]</b>	35mm [1.378] or longer	39mm [1.535] or longer	31mm [1.220] or longer

Remark: Aside from the above, there are no particular restrictions on mounting.

### Shield Plate Type (Order Codes)

Operation type Stroke mm Bore size mm [in.]	Applicable shield plate type			
	Double acting type, Double acting double rod type		Single acting push/pull type	
	5, 10, 15	20, 25, 30	5, 10	15
<b>6 [0.236]</b>	<b>BS061</b>	<b>BS062</b>	<b>BS061</b>	<b>BS062</b>
<b>10 [0.394]</b>	<b>BS101</b>	<b>BS102</b>	<b>BS101</b>	<b>BS102</b>
<b>16 [0.630]</b>	<b>BS161</b>	<b>BS162</b>	<b>BS161</b>	<b>BS162</b>

Remarks: 1. All shield plates come with 2 mounting screws.  
2. Order all shield plates separately.





## Replacement of mounting brackets

### ● Rod side mounting bracket

Remove the rod end nut, loosen the rod cover (mounting bracket) mounting screws, and remove the rod cover (mounting bracket). Assemble the replacement mounting bracket by reversing the order of procedures for removal.

For non-rotating cylinders, loosen the setscrew for plate and remove the plate assembly, and remove the rod cover (mounting bracket). For assembly, align and assemble the guide pin holes of the mounting bracket and the cylinder body, insert the plate assembly, and tighten and secure the setscrew for plate against the piston rod. In this case, retract the piston rod in the fully retracted position at the head side stroke end, maintain a clearance of about 0.5mm [0.020in.] between the plate and rod bushing, and secure the plate assembly in place.

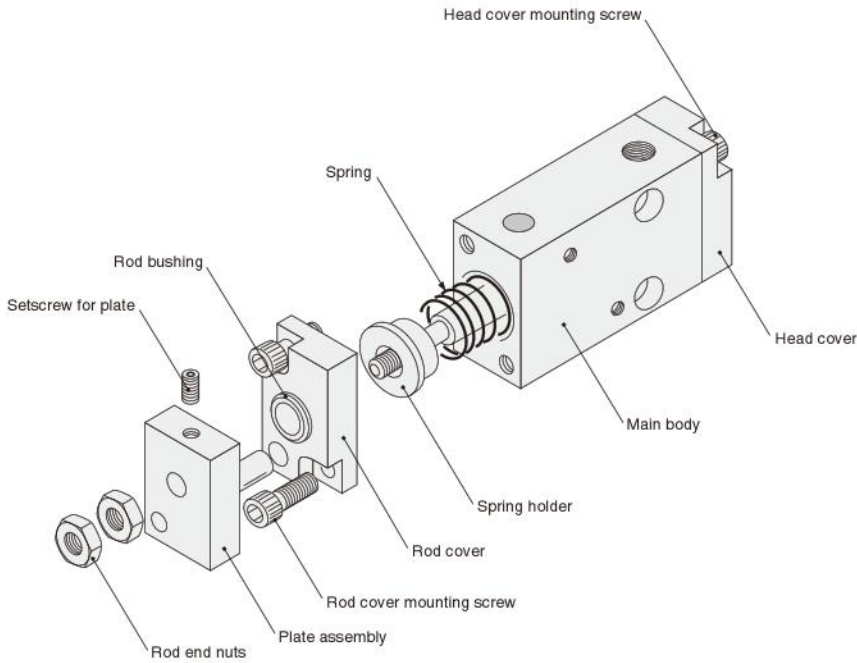

The diagram shows a non-rotating single acting push type cylinder.

### ● Head side mounting bracket

Loosen the head cover (mounting bracket) mounting screws and remove the head cover (mounting bracket). Assemble the replacement mounting bracket by reversing the order of procedures for removal.

- Cautions:**
1. To increase the mounting accuracy of the side mounting, assemble so that the rod cover and head cover do not protrude from the cylinder body, and mount so that the cylinder body contacts tightly to the device.
  2. Use the supplied mounting screws, or when using commercial screws, use the sizes shown in the table below to secure mounting brackets in place.

Bore size mm [in.]	Screw size	Length of below head mm [in.]
6 [0.236]	M2.6×0.45	6 [0.236]
10 [0.394]	M3×0.5	8 [0.315]
16 [0.630]	M4×0.7	8 [0.315]

3. Refer to the figures in the table below for the tightening torque of the non-rotating cylinder's setscrew for plate, and for the size of the Allen wrench used.

Bore size mm [in.]	Tightening torque N·cm [in·lbf]	Hexagonal bar spanner nominal size mm [in.]
6 [0.236]	49 [4.37]	1.27 [0.050]
10 [0.394]	98.1 [8.68]	1.5 [0.059]
16 [0.630]	137.3 [12.2]	2 [0.079]



## Sensor switches

### Procedure for finding the best sensing position

#### ● Setting the head side stroke end

1. Push piston rod to the fully retracted position.
2. Install a sensor switch in a holder without tightening a mounting screw all the way, move the switch from head side to rod side until it turns ON (for ZC130□, ZC153□ and CS11T□, when the LED lights up), then move the switch 1 notch (= 1mm [0.039in.]) for ZC130□ and ZC153□, or 2 notches (= 2mm [0.079in.]) for CS5T□ and CS11T□ toward the rod side, and tighten the mounting screw.

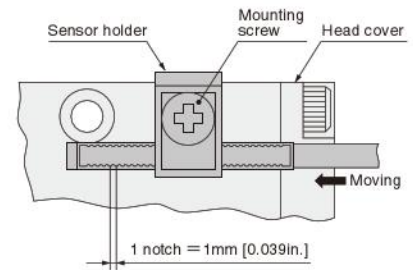

#### ● Setting the rod side stroke end

Conduct the same procedure as the head side, but on the reversed way.

1. Pull piston rod to the fully extended position.
2. Install a sensor switch in a holder without tightening a mounting screw all the way, move the switch from rod side to head side until it turns ON, then move the switch 1 notch (=1mm [0.039in.]) for ZC130□ and ZC153□, or 2 notches (=2mm [0.079in.]) for CS5T□ and CS11T□ toward head side, and tighten the mounting screw.

#### ● Caution when installing cylinder with sensor switch

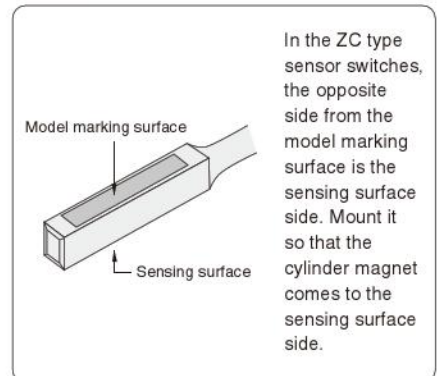



## General precautions

### Piping

1. In applications with high load ratio or high speed, use an externally mounted stopper to prevent direct shock to the cylinder.
2. Use the cylinder body's 4-M3 × 0.5 female thread only for mounting a sensor switch or shield plate.

### Piping

Always thoroughly blow off (use compressed air) the tubing before connecting it to the cylinder. Entering chips, sealing tape, rust, etc., generated during piping work could result in air leaks or other defective operation.

### Atmosphere

1. If using in locations subject to dripping water, dripping oil, etc., or to large amounts of dust, use a cover to protect the unit.
2. The product cannot be used when the media or ambient atmosphere contains any of the substances listed below.  
Organic solvents, phosphate ester type hydraulic oil, sulphur dioxide, chlorine gas, or acids, etc.

### Lubrication

The product can be used without lubrication, if lubrication is required, use Turbine Oil Class 1 (ISO VG32) or equivalent.

Avoid using spindle oil or machine oil.

### Media

1. Use air for the media. For the use of any other media, consult us.
2. Air used for the cylinder should be clean air that contains no deteriorated compressor oil, etc. Install an air filter (filtration of a minimum 40 µm) near the cylinder or valve to remove collected liquid or dust. In addition, drain the air filter periodically.