



φ2 Tube Fittings

- Mini type quick fittings
- Speed controllers with quick fittings
- TAC fittings
- Urethane tubes

Mini type quick fittings



Speed controllers with quick fittings



TAC fittings



Urethane tubes



INDEX

Mini type quick fittings



- Mini type quick fittings for $\phi 2$ tubes.
- One-touch connections are speedy.
- Select from 17 types of shapes.

Page 2

Speed controllers with quick fittings (low-speed control type)



- Speed controllers with quick fittings for $\phi 2$ tubes.
- All low speed control types for $\phi 2$ tubes.
- Superior flow rate characteristics and fine tuning adjustments in the low-speed range is easy.

Page 10

TAC fittings



- TAC fittings for $\phi 2$ tubes.
- Compact fittings for all kinds of compact equipment.

Page 16

Urethane tubes

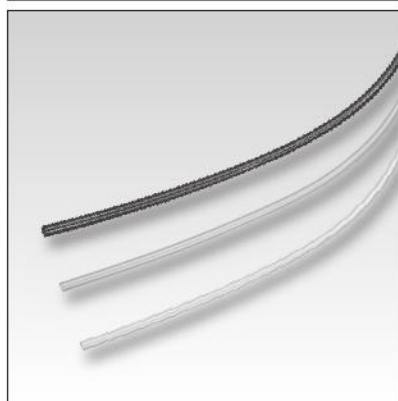

- $\phi 2$ size urethane tubes.
- Black, clear, and clear blue tube colors are available.

Page 20

KOGANEI

Auxiliary components

QUICK FITTINGS MINI TYPE
Quick fittings mini type
for $\phi 2$ tubes
INDEX



RoHS Directive Compliant Product

Specifications & Order Codes	3
Dimensions	4

⚠ CAUTION

Read the "Safety Precautions" and "Handling Instructions and Precautions" on our website or in the general catalogs before using these products.

Quick fittings mini type

Specifications

Item \ Applicable tube size	$\phi 2$
Media	Air
Maximum operating pressure	0.9MPa
Operating vacuum pressure	-100 kPa
Operating temperature range	0 to 60°C
Recommended tube ^{Note}	Urethane tubes
Sales unit	1 pack (10 pcs.)

Remarks: Gasket or seal is already attached.

Note: Use Koganei tubes. Use tubes that have an outer diameter precision that is within a nominal diameter of ± 0.1 mm. Also, note that you cannot use the $\phi 1.8$ outer diameter tubes produced by Koganei.

Internal Configuration and Materials of Major Parts

<For $\phi 2$ tubes>

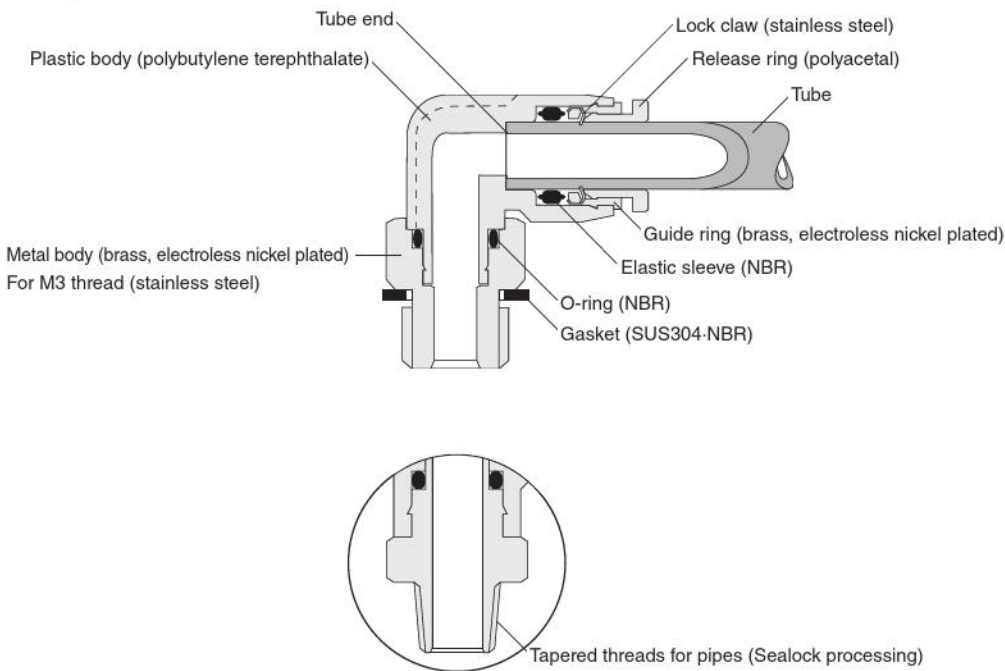

Order Codes

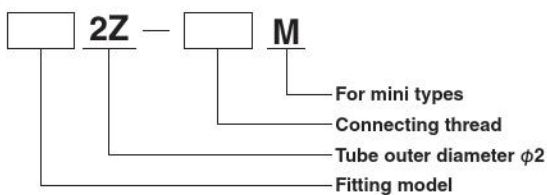

* See pages ④ to ⑨ for details on models of fittings.

Note: Use Koganei tubes. Use tubes that have an outer diameter precision that is within a nominal diameter of ± 0.1 mm. Also, note that you cannot use the $\phi 1.8$ outer diameter tubes produced by Koganei.

Straight
TS

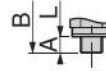
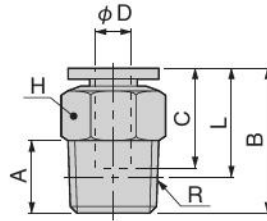

Metric thread type

Release ring



Model	Tube outer diameter ϕD	R	A	B	L	C	Width across flats H	X	Y	Effective area (mm ²)	Mass g
TS2Z-M3M	2	M3x0.5	2.5	12.1	9.6	8.4	5	4.8	—	0.7	0.9
TS2Z-M5M		M5x0.8	3	11.8	8.8		7			2.2	
TS2Z-01M		R1/8	8	15.4	11.4		10			7.4	

Straight with hexagon socket
TSH

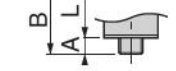
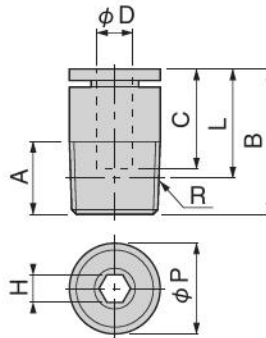

Metric thread type

Release ring



Model	Tube outer diameter ϕD	R	A	B	L	C	Width across flats H	ϕP	X	Y	Effective area (mm ²)	Mass g
TSH2Z-M3M	2	M3x0.5	2.5	12.1	9.6	8.4	1.3	5	4.8	—	1	0.8

Female straight
TSM

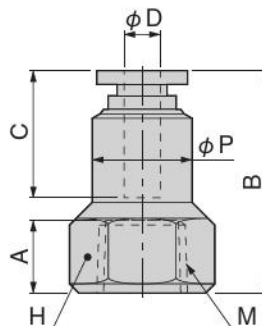

Release ring

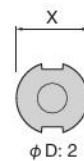

Model	Tube outer diameter ϕD	M	A	B	ϕP	C	Width across flats H	X	Y	Effective area (mm ²)	Mass g
TSM2Z-M3M	2	M3x0.5	4	13.9	5	8.4	5	4.8	—	0.9	1.4

Dimensions (mm)

Note: The photos and dimension diagrams are examples of different models of fittings.

Union straight
US

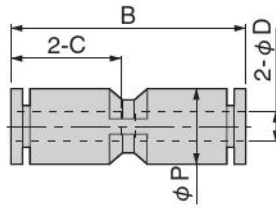

Release ring

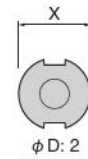

Model	Tube outer diameter φD	B	φP	C	X	Y	Effective area (mm ²)	Mass g
US2ZM	2	18.5	6	8.4	4.8	—	0.9	1

Different diameter union
USD

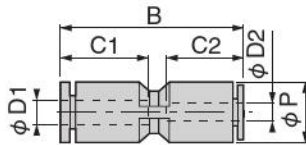

Release ring

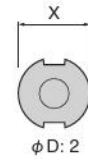

Model	Tube outer diameter φD1	Tube outer diameter φD2	B	φP	C1	C2	φD1 side release ring		φD2 side release ring		Effective cross section area (mm ²)	Mass g
							X	Y	X	Y		
USD3-2ZM	3	2	19.1	6	9.3	8.4	7	6	4.8	—	0.9	1
USD4-2ZM	4	2	22.4	8	11		9.8	7.8	4.8	—	0.7	1.8

Reducer
UR

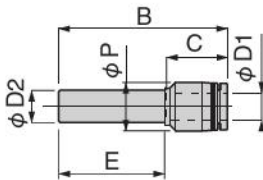

Release ring

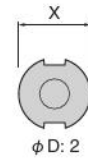

Model	Tube outer diameter φD1	Applicable fitting diameter φD2	B	E	φP	C	X	Y	Effective cross section area (mm ²)	Mass g
UR3-2ZM	2	3	26.3	17	6	8.4	4.8	—	0.9	0.6
UR4-2ZM	2	4	26.3	17	6	8.4	4.8	—	0.8	0.7

Elbow
TL

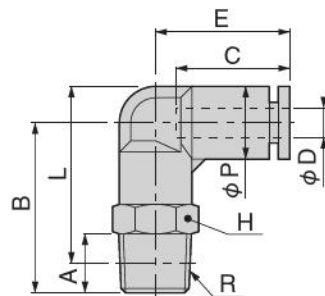

Release ring



Metric thread type

Model	Tube outer diameter φD	R	A	B	L	φP	C	E	Width across flats H	X	Y	Effective cross section area (mm ²)	Mass g
TL2Z-M3M	2	M3×0.5	2.5	12	12.5	6	8.4	10.3	5.5	4.8	—	0.5	1.4
TL2Z-M5M		M5×0.8	3	13.5	13.5				8			0.7	2.7
TL2Z-01M	2	R1/8	8	16	15	6	8.4	10.3	10	4.8	—	0.7	5.5

Dimensions (mm)

Note: The photos and dimension diagrams are examples of different models of fittings.

Long elbow
TLL

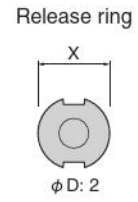
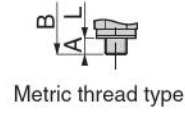
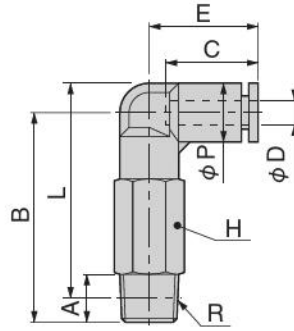

Model	Tube outer diameter ϕD	R	A	B	L	ϕP	C	E	Width across flats H	X	Y	Effective cross section area (mm ²)	Mass g
TLL2Z-M3M	2	M3×0.5	2.5	19	19.5	6	8.4	10.3	5.5	4.8	—	0.5	2.7
TLL2Z-M5M	2	M5×0.8	3	25	25	6	8.4	10.3	8	4.8	—	0.6	7.6

Union elbow
UL

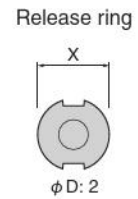
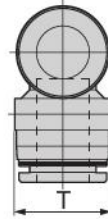
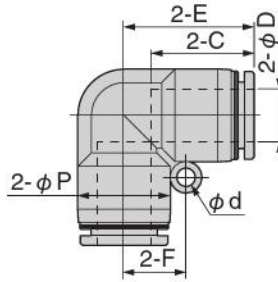

Model	Tube outer diameter ϕD	ϕP	C	E	ϕd	F	T	X	Y	Effective cross section area (mm ²)	Mass g
UL2ZM	2	6	8.4	10.3	3.2	4.5	6	4.8	—	0.7	1.1

Different diameter socket elbow
ULAD

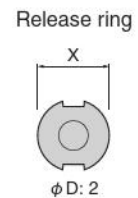
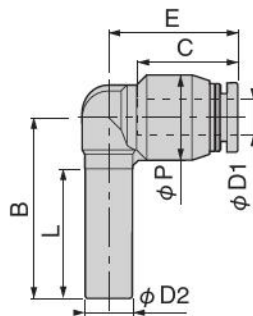

Model	Tube outer diameter $\phi D1$	Applicable fitting diameter $\phi D2$	B	ϕP	C	E	L	X	Y	Effective cross section area (mm ²)	Mass g
ULAD3-2ZM	2	3	21	6	8.4	10.3	17	4.8	—	0.7	0.7

Dimensions (mm)

Note: The photos and dimension diagrams are examples of different models of fittings.

Tee
TT

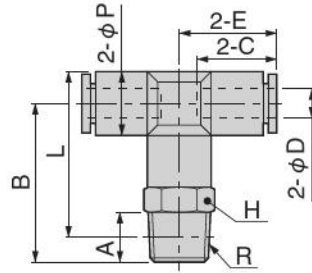

Metric thread type

Release ring

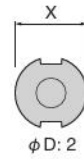

Model	Tube outer diameter φD	R	A	B	L	φP	C	E	Width across flats H	X	Y	Effective cross section area (mm ²)	Mass g
TT2Z-M3M	2	M3×0.5	2.5	12	12.5	6	8.4	10.25	5.5	4.8	—	0.5	1.9
TT2Z-M5M		M5×0.8	3	13.5	13.5				8			0.6	3.2

Branch tee
TB

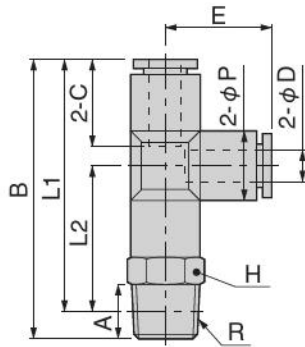

Metric thread type

Release ring

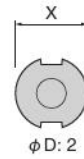

Model	Tube outer diameter φD	R	A	B	L1	L2	φP	C	E	Width across flats H	X	Y	Effective cross section area (mm ²)	Mass g
TB2Z-M3M	2	M3×0.5	2.5	22.3	19.8	9.5	6	8.4	10.3	5.5	4.8	—	0.5	1.9
TB2Z-M5M		M5×0.8	3	23.8	20.8	10.5				8			0.8	3.2

Union tee
UT

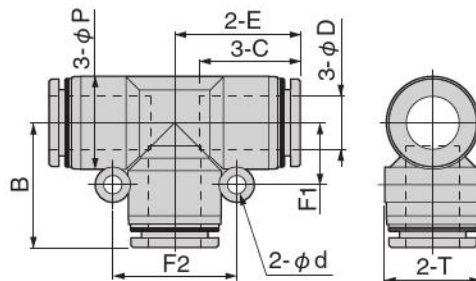

Release ring

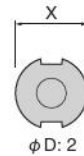

Model	Tube outer diameter φD	φP	C	E	φd	F1	F2	T	B	X	Y	Effective cross section area (mm ²)	Mass g
UT2ZM	2	6	8.4	10.25	3.2	4.5	9	6	10.3	4.8	—	0.6	1.6

Different diameter union tee
UTD

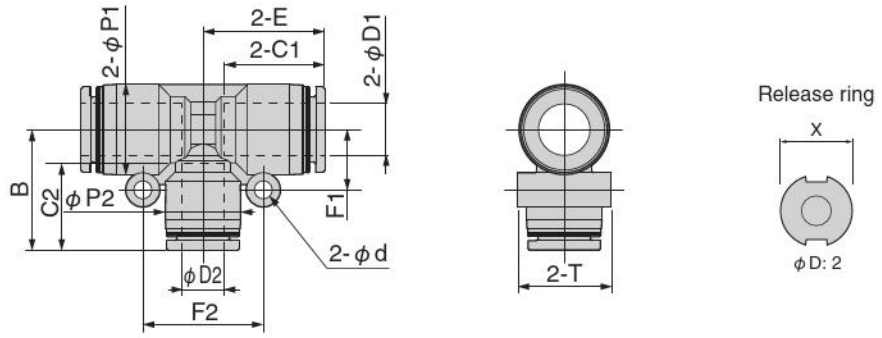

Model	Tube outer diameter φD1	Tube outer diameter φD2	φP1	φP2	C1	C2	E	φd	F1	F2	B	T
UTD3-2ZM	3	2	6	6	9.3	8.4	10.8	3.2	4.5	9	10.3	6

Model	D1 side release ring		D2 side release ring		Effective cross section area (mm ²)	Mass g
	X	Y	X	Y		
UTD3-2ZM	7	6	4.8	—	0.8	1.7

Union Y
UY

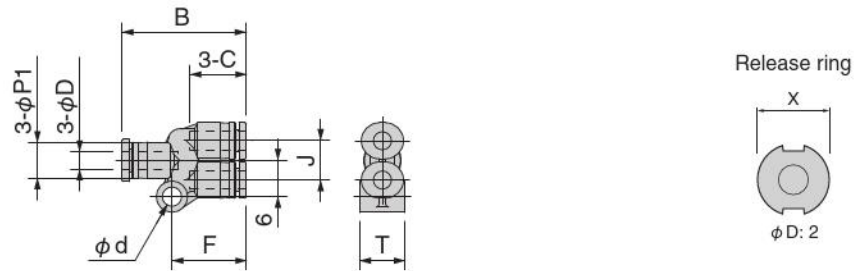

Model	Tube outer diameter φD	B	φP1	φP2	C	J	φd	F	T	X	Y	Effective cross section area (mm ²)	Mass g
UY2ZM	2	19.5	6	—	8.4	6.5	3.2	11.8	7.4	4.8	—	0.6	1.7

Dimensions (mm)

Note: The photos and dimension diagrams are examples of different models of fittings.

Plug UP

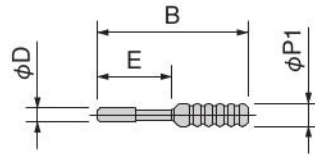

Model	Applicable fitting diameter ϕD	B	E	$\phi P1$	$\phi P2$	Mass g
UP2ZM	2	20	9.8	3	—	0.1

Cap UC

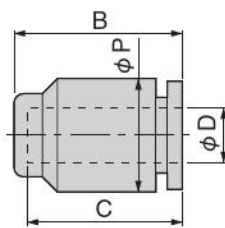

Release ring

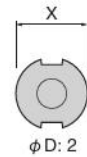

Model	Tube outer diameter ϕD	B	ϕP	C	X	Mass g
UC2ZM	2	9.8	6	8.4	4.8	0.5

KOGANEI

Auxiliary components

SPEED CONTROLLERS WITH QUICK FITTINGS

Speed controllers with quick fittings for $\phi 2$ tubes INDEX



RoHS Directive Compliant Product

Low-Speed Control Type

Specifications & Order Codes 11

Dimensions 13

Flow Rate Characteristics 15

CAUTION

Read the "Safety Precautions" and "Handling Instructions and Precautions" on our website or in the general catalogs before using these products.

Speed controllers with quick fittings

Low-Speed Control Type

Specifications

Item	Applicable tube size	$\phi 2$
Media	Air (cannot be used for vacuum)	
Operating pressure range	0.1 to 0.9 MPa	
Cracking pressure	0.05MPa	
Operating temperature range	0 to 60°C	
Recommended tube ^{Note}	Urethane tubes	
Sales unit	1 pc.	

Remarks: Gasket or seal is already attached. (Except for **SSUC□**.)

Note: Use Koganei tubes. Use tubes that have an outer diameter precision that is within a nominal diameter of ± 0.1 mm. Also, note that you cannot use the $\phi 1.8$ outer diameter tubes produced by Koganei.

Internal Configuration Diagram and Materials of Major Parts

● Elbow model SCC

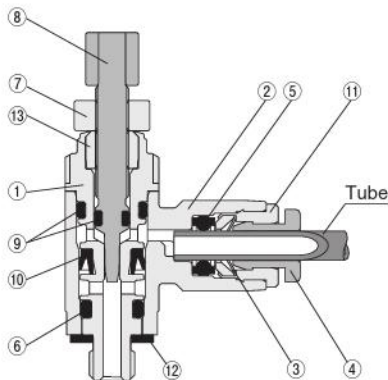

No.	Name	Materials
①	Metal body	Stainless steel ^{Note}
②	Plastic body	Polybutylene terephthalate
③	Lock claw	Stainless steel
④	Release ring	Polyacetal
⑤	Elastic sleeve	Synthetic rubber (NBR)
⑥	O-ring	Synthetic rubber (NBR)
⑦	Lock nut	Stainless steel
⑧	Needle	Stainless steel
⑨	O-ring	Synthetic rubber (NBR)
⑩	Diaphragm	Synthetic rubber (H-NBR)
⑪	Guide ring	Brass (Electroless nickel plated)
⑫	Gasket	Stainless steel + synthetic rubber (NBR)
⑬	Upper plug	Stainless steel

Note: Connecting thread **M5** and union type are brass (electroless nickel plated)

Body Configuration and Control Direction

● Elbow model SCC

A: Meter-out control B: Meter-in control

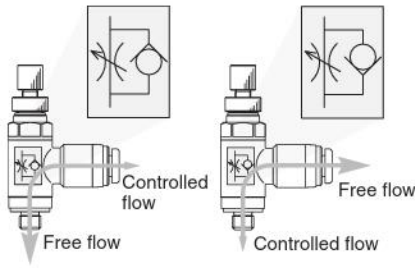

● Union model SSUC

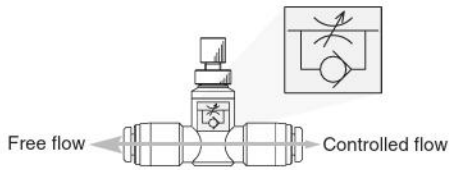

Remark: Be sure to check the control direction by the symbol on the product.

● Straight model SSC

A: Meter-out control

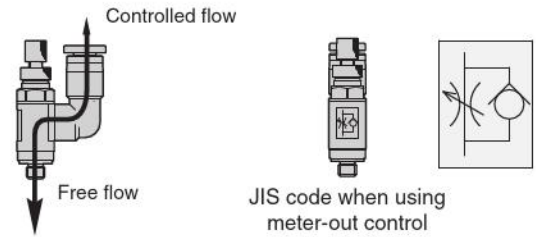

B: Meter-in control

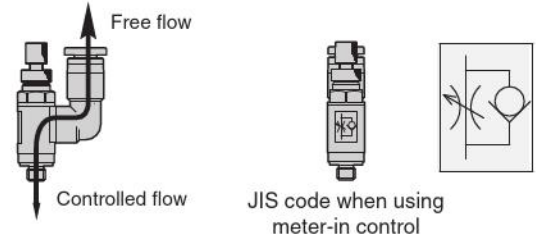

Order Codes

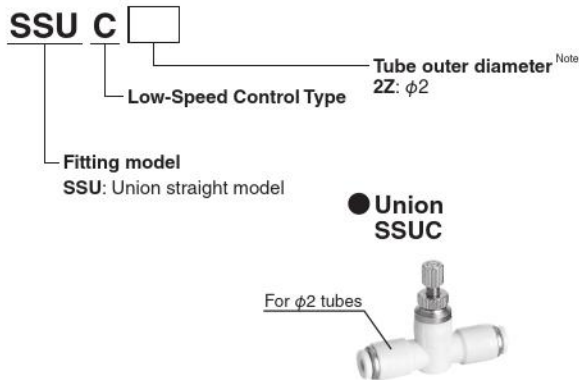
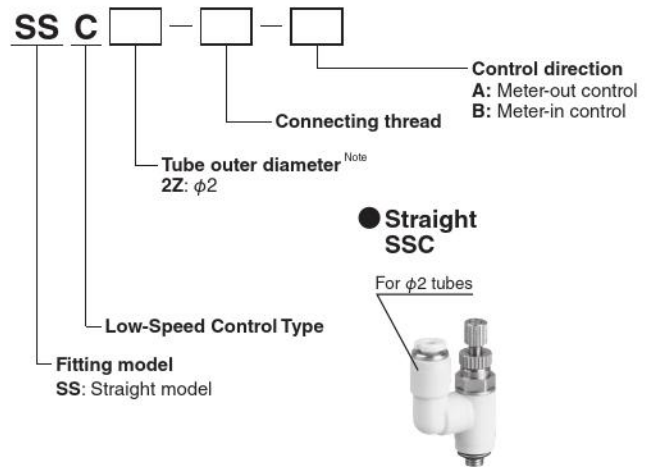
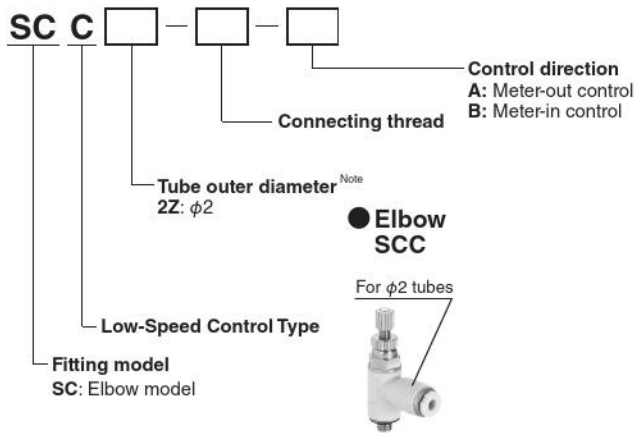

Note: Use Koganei tubes. Use tubes that have an outer diameter precision that is within a nominal diameter of ± 0.1 mm. Also, note that you cannot use the $\phi 1.8$ outer diameter tubes produced by Koganei.

* See pages 13 to 14 for details on models.

Elbow
SCC

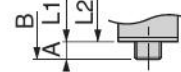
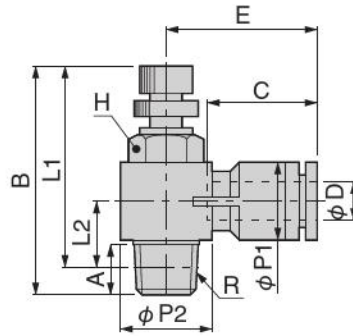

Metric thread type

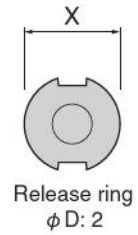

Release ring
φD: 2

Model ^{Note}	Tube outer diameter φD	R	A	B		L1		L2	φP1	φP2	C	E	Width across flats H	X	Y	Mass g
				MAX	MIN	MAX	MIN									
SCC2Z-M3-□	2	M3×0.5	2.5	25.7	23	23.2	20.5	6.4	6	6.2	8.4	12.5	5.5	4.8	—	2.7
SCC2Z-M5-□		M5×0.8	3	27.2	24.5	24.2	21.5	7.2				8.8	13.5			8

Note: Enter an A in the empty square □ in the model number if you want meter out control, and enter a B if you want meter in control.

Straight
SSC

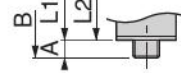
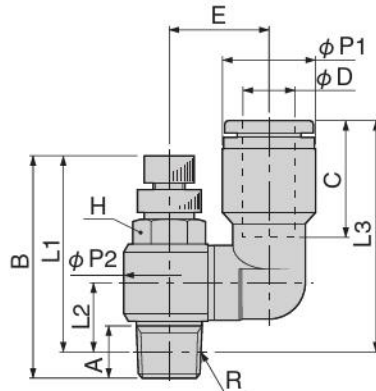

Metric thread type

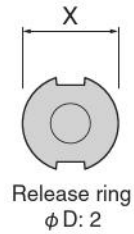

Release ring
φD: 2

Model ^{Note}	Tube outer diameter φD	R	A	B		L1		L2	L3	φP1	φP2	C	E	Width across flats H	X	Y	Mass g
				MAX	MIN	MAX	MIN										
SSC2Z-M3-□	2	M3×0.5	2.5	25.7	23	23.2	20.5	6.9	19.2	6.1	6.2	8.4	8.2	5.5	4.8	—	2.8
SSC2Z-M5-□		M5×0.8	3	27.2	24.5	24.2	21.5	7.8	20.1				8.8	9.4			8

Note: Enter an A in the empty square □ in the model number if you want meter out control, and enter a B if you want meter in control.

Dimensions (mm)

Note: The photos and dimension diagrams are examples of different models of fittings.

Union SSUC

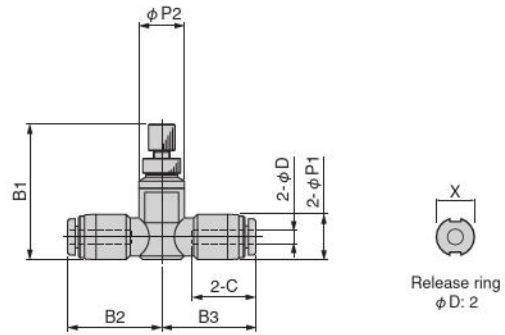

Model	Tube outer diameter ϕD	B1		B2	B3	C	$\phi P1$	$\phi P2$	X	Y	Mass g
		MAX	MIN								
SSUC2Z	2	20.6	17.9	12.5	12.5	8.4	6	6	4.8	—	2.8

Flow Rate Characteristics

SCC2Z-M3-
 SSC2Z-M3-

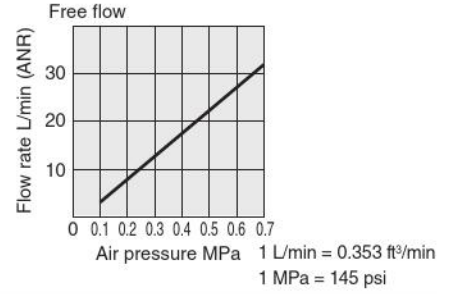
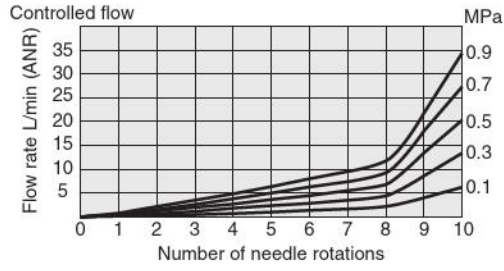

SCC2Z-M5-
 SSC2Z-M5-

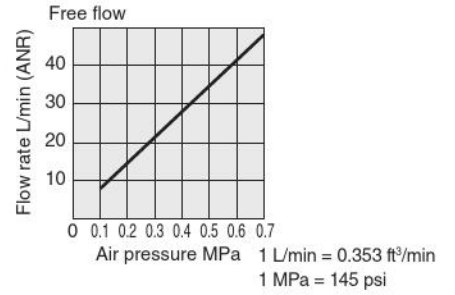
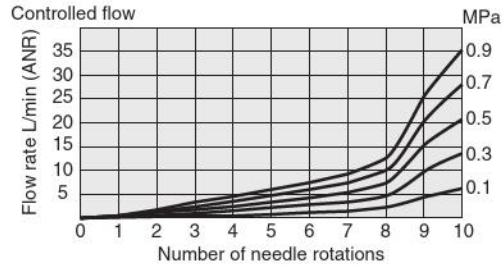

SSUC2Z

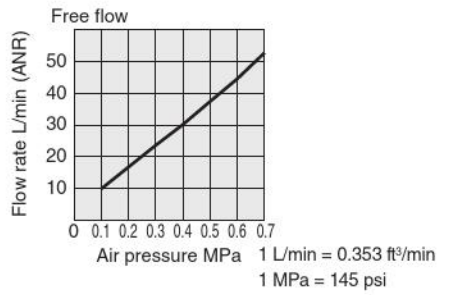
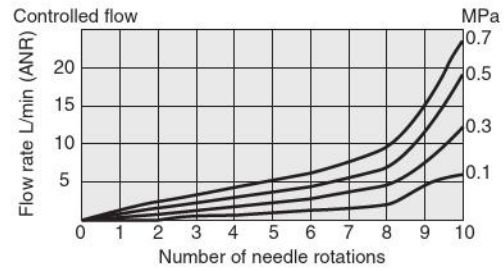

KOGANEI

Auxiliary components

TAC FITTINGS

TAC fittings for $\phi 2$ tubes

INDEX



RoHS Directive Compliant Product

Types and Specifications (Fittings for Urethane Tubes) —————	17
Dimensions —————	18
SUS Specifications · NCU Specifications · Table of Models —————	19

 CAUTION

Read the “Safety Precautions” and “Handling Instructions and Precautions” on our website or in the general catalogs before using these products.

TAC fittings

Types and Specifications

Fittings for urethane tubes

Name and type		Straight	
			
Model	BF2ZBU-M3 (-HN)	BF2ZBU (-HN)	
Port size	M3x0.5 (male thread)	M5x0.8 (male thread)	
Applicable tube ^{Note 2} ODxD mm	2.0x1.2		
Effective area mm ²	0.45	0.45	
Operating temperature range °C	0 to 60		
Material	Stainless steel		
Weight g	0.7 (0.4) ^{Note 1}	1.6 (1.3) ^{Note 1}	
Remark	Attachments/ accessories	With 1 gasket and 1 holder	
	Sales unit	1 pack (10 pcs.)	

Name and type		Elbow	
			
Model	UER2ZBU-M3(-HN)	UER2ZBU(-HN)	
Port size	M3x0.5 (male thread)	M5x0.8 (male thread)	
Applicable tube ^{Note 2} ODxD mm	2.0x1.2		
Effective area mm ²	0.35	0.35	
Operating temperature range °C	0 to 60		
Material	Stainless steel		
Weight g	1.7 (1.4) ^{Note 1}	2.6 (2.3) ^{Note 1}	
Remark	Attachments/ accessories	With 1 gasket and 1 holder	
	Sales unit	1 pack (5 pcs.)	

Name and type		Different diameter nipple	
			
Model	NBF3-2ZBU(-HN)	NBF4-2ZBU(-HN)	
Port size	-		
Applicable tube ^{Note 2} ODxD mm	2.0x1.2-3x1.5	2.0x1.2-4x2.5	
Effective area mm ²	0.45	0.45	
Operating temperature range °C	0 to 60		
Material	Stainless steel		
Weight g	0.5 (0.2) ^{Note 1}	0.6 (0.3) ^{Note 1}	
Remark	Attachments/ accessories	With 1 holder	
	Sales unit	1 pack (10 pcs.)	

Note 1: Figures within parentheses () show the mass without the holder (-HN)

Note 2: Note that you cannot use the φ1.8 outer diameter tubes on the φ2 TAC fittings

Additional parts

Holder Mass: 0.3 g

Order code

H-2ZBU (One pack 10 pcs.)



Dimensions (mm)

Straight

Remarks: -HN does not have a holder.

●BF2ZBU-M3 (-HN)

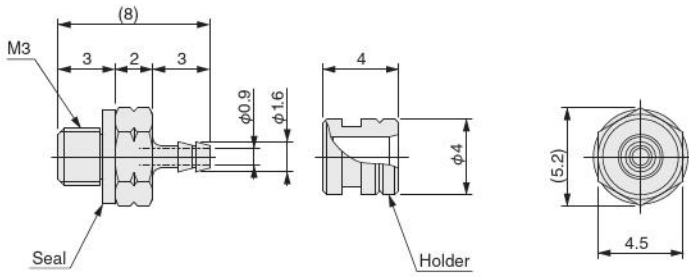

●BF2ZBU (-HN)

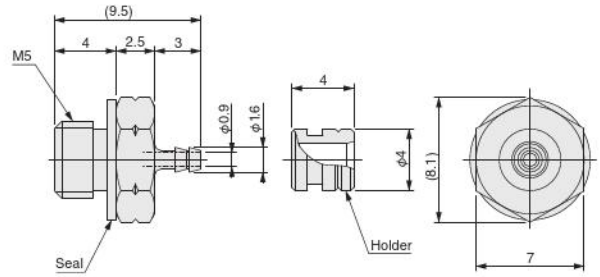

Elbow

●UER2ZBU-M3 (-HN)

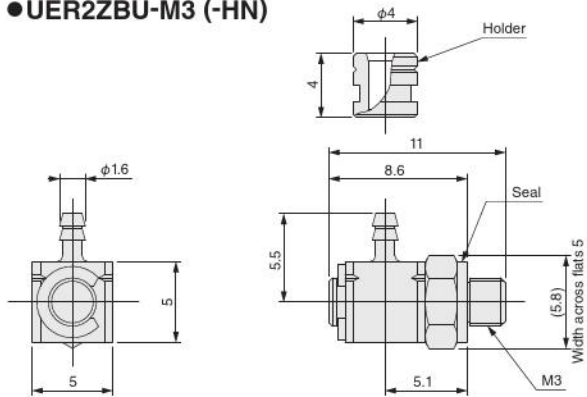

●UER2ZBU (-HN)

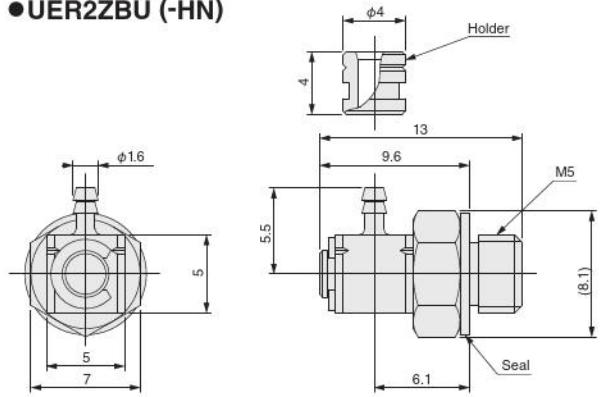

Different diameter nipple

●NBF3-2ZBU (-HN)

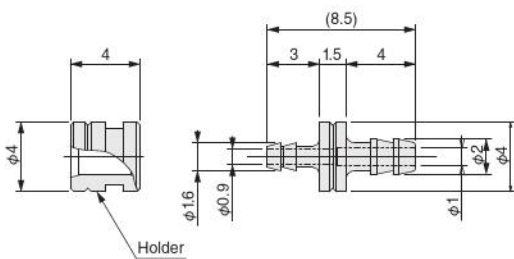

●NBF4-2ZBU (-HN)

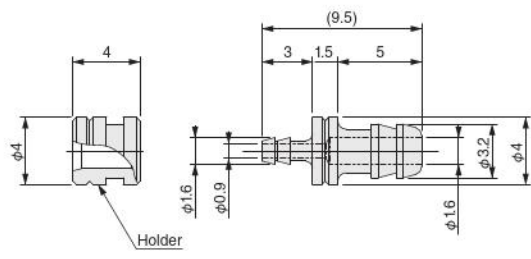

* The standard models support NCU specifications and SUS specifications, so order the standard model.

● **Table of models (SUS Specifications·NCU Specifications)**

Name	Standard model (Reference)	SUS Specification Models	NCU Specification Models
Straight	BF2ZBU-M3(-HN)		Order the standard model
	BF2ZBU(-HN)		
Elbow	UER2ZBU-M3(-HN)		Order the standard model
	UER2ZBU(-HN)		
Different diameter nipple	NBF3-2ZBU(-HN)		Order the standard model
	NBF4-2ZBU(-HN)		

KOGANEI

Auxiliary components

URETHANE TUBES

**φ2 size urethane
tubes
INDEX**

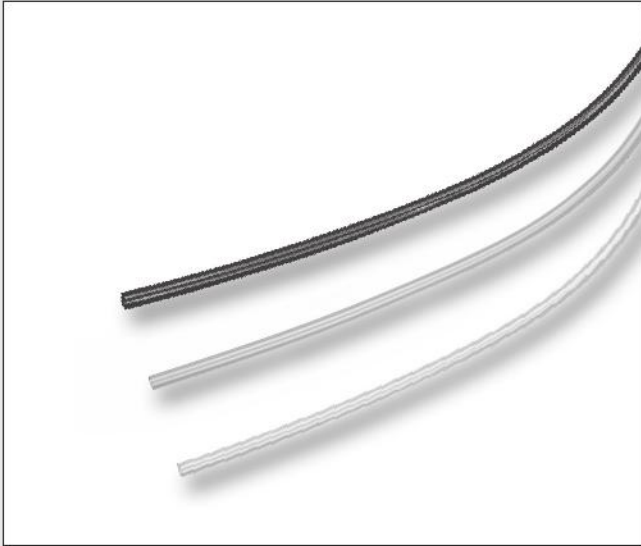

RoHS Directive Compliant Product

Urethane tubes

Specifications & Order Codes _____ 21

⚠ CAUTION

Read the "Safety Precautions" and "Handling Instructions and Precautions" on our website or in the general catalogs before using these products.

Urethane tubes

Specifications

● Urethane tubes

Name		Urethane tubes
Item	Model	U2Z
OD×ID ^{Note 1}	mm	2.0×1.2
Media		Air
Operating pressure range	Positive pressure	0 to 0.8 MPa (at 20°C)
	Negative pressure	-99.9 to 0 kPa
Operating temperature range ^{Note 2} °C		-15 to 60
Material		Polyurethane
Minimum bending radius	mm	5
Color		Black, clear, and clear blue
Unit of mass	g/m	2.4
Sales unit		1 roll (20 or 100 m)

Note 1: Note that you cannot use the ϕ 1.8 TAC quick fittings, speed controller with ϕ 1.8 quick fittings, or ϕ 1.8 TAC fittings.

Note 2: The operating temperature range shows values for when the tube is in a stationary state. For the operating temperature range in applications where the tube is forced to swing, contact your nearest Koganei sales office.

Order Codes

● Urethane tubes

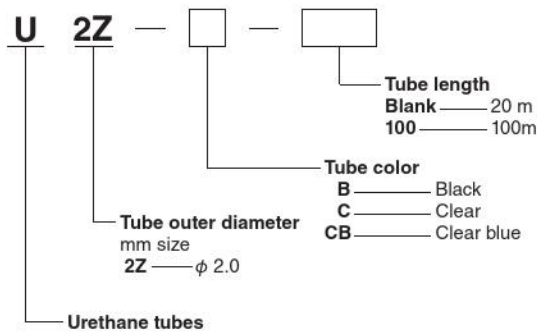

Operating Temperature and Pressure, and Bursting Pressure

● Urethane tubes

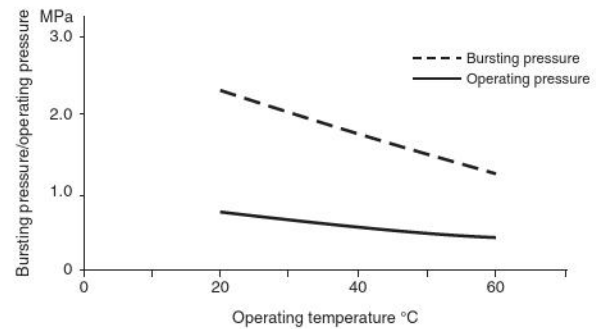

Note: Note that you cannot use the ϕ 1.8 TAC quick fittings, speed controller with ϕ 1.8 quick fittings, or ϕ 1.8 TAC fittings.

Limited Warranty

KOGANEI CORP. warrants its products to be free from defects in material and workmanship subject to the following provisions.

Warranty Period The warranty period is 180 days from the date of delivery.

Koganei Responsibility If a defect in material or workmanship is found during the warranty period, KOGANEI CORP. will replace any part proved defective under normal use free of charge and will provide the service necessary to replace such a part.

Limitations

- This warranty is in lieu of all other warranties, expressed or implied, and is limited to the original cost of the product and shall not include any transportation fee, the cost of installation or any liability for direct, indirect or consequential damage or delay resulting from the defects.

- KOGANEI CORP. shall in no way be liable or responsible for injuries or damage to persons or property arising out of the use or operation of the manufacturer's product.

- This warranty shall be void if the engineered safety devices are removed, made inoperative or not periodically checked for proper functioning.

- Any operation beyond the rated capacity, any improper use or application, or any improper installation of the product, or any substitution upon it with parts not furnished or approved by KOGANEI CORP., shall void this warranty.

- This warranty covers only such items supplied by KOGANEI CORP. The products of other manufacturers are covered only by such warranties made by those original manufacturers, even though such items may have been included as the components.

The specifications are subject to change without notice.

URL <http://www.koganei.co.jp>

E-mail: overseas@koganei.co.jp



KOGANEI CORPORATION

OVERSEAS DEPARTMENT

3-11-28, Midori-cho, Koganei City, Tokyo 184-8533, Japan
Tel: 81-42-383-7271 Fax: 81-42-383-7276

KOGANEI INTERNATIONAL AMERICA, INC.

48860 Milmont Drive, suite 108C, Fremont, California 94538
Tel: 1-510-744-1626 Fax: 1-510-744-1676

SHANGHAI KOGANEI INTERNATIONAL TRADING CORPORATION

Room 2606-2607, Tongda Venture Building No.1, Lane 600, Tianshan Road,
Shanghai, 200051, China
Tel: 86-21-6145-7313 Fax: 86-21-6145-7323

TAIWAN KOGANEI TRADING CO., LTD.

Rm. 2, 13F., No88, Sec. 2, Zhongxiao E. Rd., Zhongzheng Dist., Taipei City 100,
Taiwan (ROC)
Tel: 886-2-2393-2717 Fax: 886-2-2393-2719

KOGANEI KOREA CO., LTD.

6F-601, Tower Bldg., 1005, Yeongdeong-dong, Giheung-gu, Yongin-si, Gyeonggi-do,
446-908, Korea
Tel: 82-31-246-0414 Fax: 82-31-246-0415

KOGANEI (THAILAND) CO., LTD.

555 Rasa Tower 1, 12th Floor, Unit 1202 and 1207, Phaholyothin Road, Chatuchak, Chatuchak,
Bangkok 10900 Thailand
Tel: 66-2-937-4250 Fax: 66-2-937-4254

KOGANEI AUTOMATION (MALAYSIA) SDN.BHD.

Suite 29-2, Level 29, Menara 1MK, No.1, Jalan Kiara, Mont Kiara
50480, Kuala Lumpur, Malaysia
Tel: 60-12-537-7086

KOGANEI ASIA PTE. LTD.

69 Ubi Road 1, #05-18 Oxley Bizhub, Singapore 408731
Tel: 65-6293-4512 Fax: 65-6293-4513