

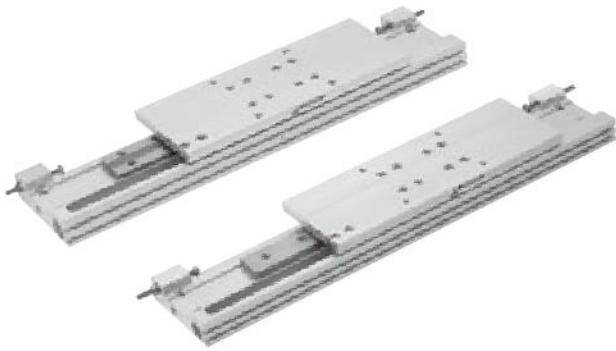

CAD drawing data catalog  
is available.



# KOGANEI

## ACTUATORS GENERAL CATALOG



# WT SLIDE TABLES

## CONTENTS

Features	1017
Handling Instructions and Precautions	1019
Specifications	1023
Order Codes	1024
Inner Construction, Major Parts and Materials	1025
Dimensions of AWT16	1026
Dimensions of AWT20	1027
Sensor Switches	1028

WT SLIDE TABLES

# Discontinued



**Caution**

Before use, be sure to read the "Safety Precautions" on p. 57.



alpha series

# WT SLIDE TABLES

The Alpha Series WT slide table uses a wide type linear guide which offers for more stable movement and rigidity. It is an easy-to-use high-performance actuator with wider stroke adjusting range.

## Wider linear guide★ with improved rigidity

★ **Width of the rail: 30mm [1.181in.] (φ 16), 42mm [1.654in.] (φ 20) with 2 sliders**

- **Cylinder bore size: φ 16 [0.630in.], φ 20 [0.787in.]**
- **Standard strokes: 50, 100, 150, 200mm**  
(Stroke adjusting range: 0 ~ -64mm [0 ~ -2.520in.] (φ 16),  
0 ~ -58mm [0 ~ -2.283in.] (φ 20))

● **Allowable yawing moment (My)**

- φ 16 : **24N·m** [17.7ft·lbf]
- φ 20 : **30N·m** [22.1ft·lbf]

**Allowable static load**

**7000N** [1574lbf.]  
(For φ 20)

**6000N** [1349lbf.]  
(For φ 16)

● **Allowable rolling moment (Mr)**

- φ 16 : **27N·m** [19.9ft·lbf]
- φ 20 : **44N·m** [32.5ft·lbf]

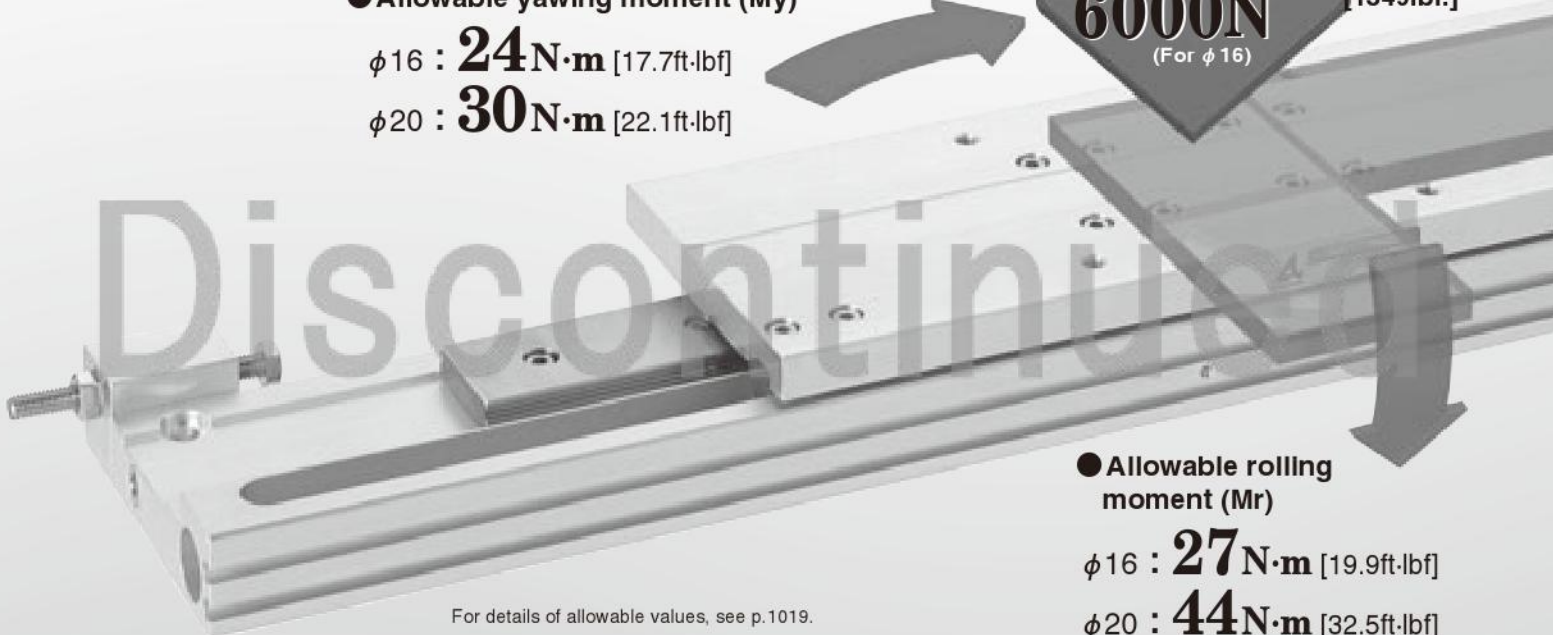

For details of allowable values, see p.1019.

### High rigidity and wider linear guide

Rigidity valuing design with wider linear guide and 2 sliders allows larger moments.

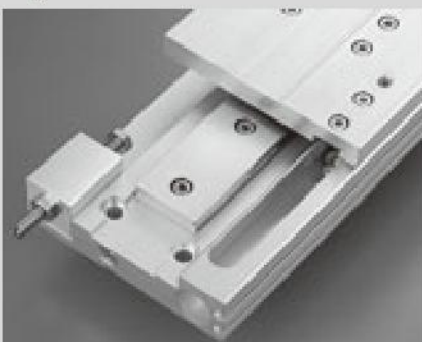

1017

### Stroke adjustment of $-32^{(\phi 16)}$ mm [-1.260in.] and $-29^{(\phi 20)}$ mm [-1.142in.] (one side)

Enables fine adjustments of the stroke up to -64mm [-2.520in.] (φ16 [0.630in.]), -58mm [-2.283in.] (φ20 [0.787in.]) on both sides by adjusting the position of the stopper bolt and the block.



For details, see p.1022.

### Shock absorbers as standard equipment

Fixed absorption capacity type shock absorbers that improve repeatability at the end of the stroke, and reduce shocks and noise, are standard equipment.



For details, see p.1020.

# Plus precision

We have added advanced positioning precision and high rigidity to the pneumatic actuator. The Koganel Alpha Series further enhances the drive module concept, supporting superior applications and labor savings in FA line design and manufacturing with higher performance.

## and larger static load capacity!

*It is the best for transfer of the base in press fitting or crimping process, and pick & place or pick & load operations, etc.*

*Press fitting and crimping application example*

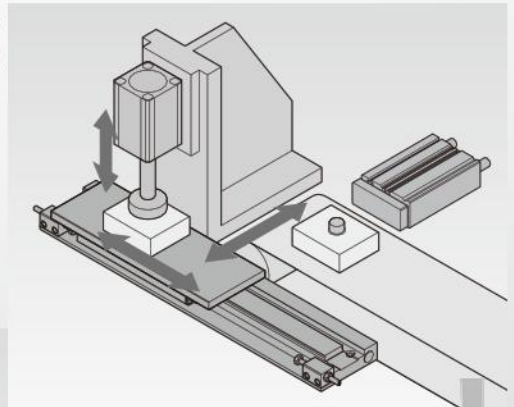

● Allowable pitching moment (Mp)

φ16 : **28N·m**  
[20.7ft·lbf]

φ20 : **33N·m**  
[24.3ft·lbf]

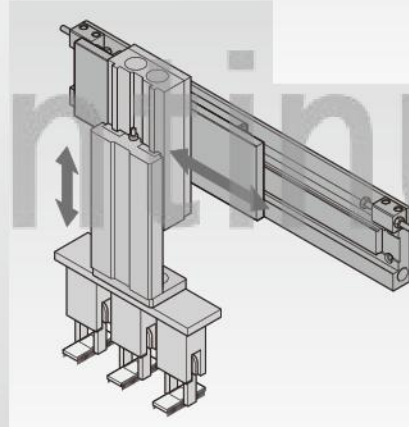

*Pick & place application example*

WT SLIDE TABLES

### ■ Embedded type sensor switch

An embedded type sensor switch which does not protrude from the body can be installed.



For details, see p.1028.

### ■ Thin shaped body & compact design

It realizes a slim appearance by a thin body design with low table height.

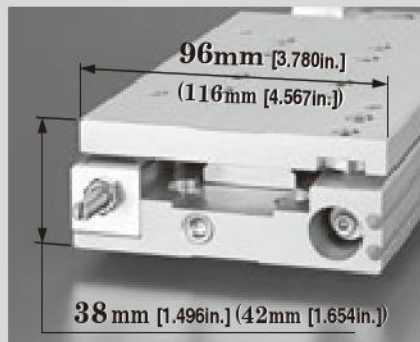

The values in parentheses ( ) are for φ20 [0.787in.].

## Handling Instructions and Precautions



### General precautions

#### Piping

Always thoroughly blow off (use compressed air) the tubing before connecting it to the WT slide table. Entering chips, sealing tape, rust, etc., generated during piping work could result in air leaks or other defective operation.

#### Atmosphere

If using in locations subject to dripping water, dripping oil, etc., or to large amounts of dust, use a cover to protect the unit.

#### Lubrication

1. The product can be used without lubrication. If lubrication is required, use Turbine Oil Class 1 (ISO VG32) or lithium soap-based No.2 equivalent.
2. Apply lithium soap-based grease on the raceway surfaces of the track rail in the guide portion every 6 months or every 300km [186mi.] of traveling distance.

#### Media

1. Use air for the media. For the use of any other media, consult us.
2. Air used for the WT slide table should be clean air that contains no deteriorated compressor oil, etc. Install an air filter (filtration of a minimum 40 μm) near the WT slide table or valve to remove collected liquid or dust. In addition, drain the air filter periodically.



### Selection and Installation

#### Allowable load and moment

Although the WT slide table can be used by directly applying the load, make sure that the load and moments do not exceed the values in the table below.

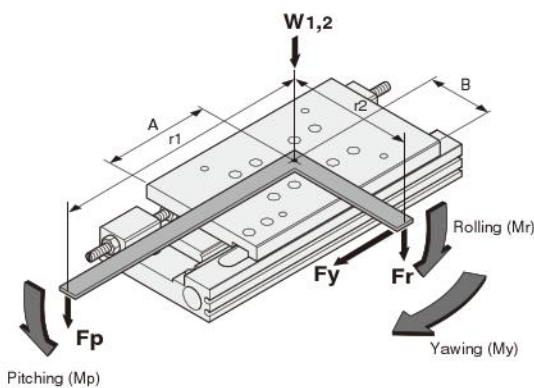

$$\text{Pitching moment : } M_p = F_p \times r_1 \text{ (N}\cdot\text{m)}$$

$$\text{Rolling moment : } M_r = F_r \times r_2 \text{ (N}\cdot\text{m)}$$

$$\text{Yawing moment : } M_y = F_y \times r_2 \text{ (N}\cdot\text{m)}$$

$$\text{Allowable static load : } W_1 \text{ (N)}$$

$$\text{Maximum load capacity : } W_2 \text{ (N)}$$

		mm [in.]				
Model	Stroke	50	100	150	200	
AWT16	A	80 [3.15]	80 [3.15]	105 [4.13]	130 [5.12]	
	B	48 [1.89]				
AWT20	A	85 [3.35]	85 [3.35]	110 [4.33]	135 [5.31]	
	B	58 [2.28]				
Model	Allowable moment	M <sub>p</sub> (Pitching) N·m [ft·lbf]	M <sub>r</sub> (Rolling) N·m [ft·lbf]	M <sub>y</sub> (Yawing) N·m [ft·lbf]	W <sub>1</sub> N [lbf.]	W <sub>2</sub> N [lbf.]
AWT16		28 [20.7]	27 [19.9]	24 [17.7]	6000 [1349]	150 [33.7]
AWT20		33 [24.3]	44 [32.5]	30 [22.1]	7000 [1574]	200 [45.0]

**Caution:** The moment including the inertia force generated when the load is moved or stopped must not exceed the values in the above table.  
Keep the load and the speed within a range of the shock absorber capacity graph.



## Selection and Installation

### Displacement of table end caused by allowable bending moment (reference value)

#### ● AWT16

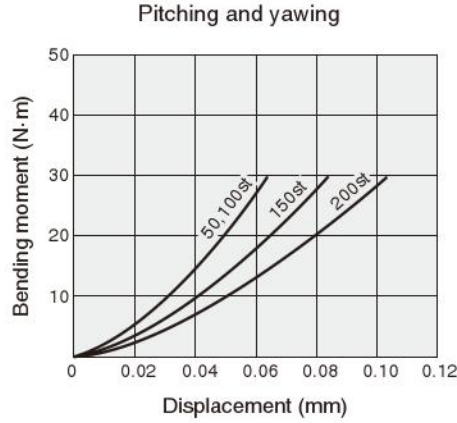
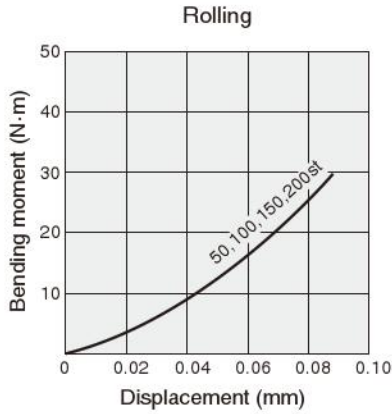

#### ● AWT20

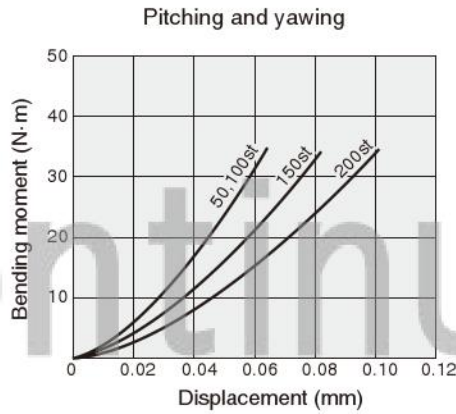
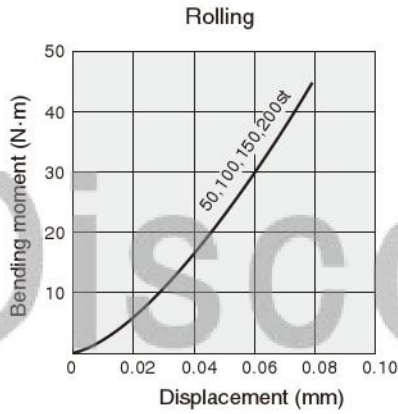

1 N·m = 0.7376 ft·lbf  
1 mm = 0.0394 in.

### Shock absorber absorption capacity

The WT slide table is equipped with shock absorbers as standard equipment, but the mass and the impact speed which can be absorbed should be within the ranges of the "Shock absorber capacity graph" below. It cannot be used with speeds in excess of the maximum operating speed of 1000 mm/s [39.4 in./sec.].

#### Shock absorber capacity graph

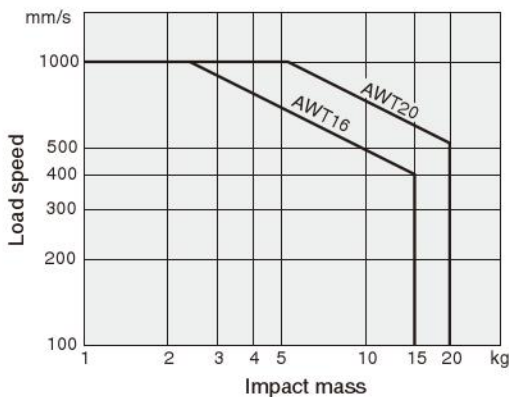

Remark: On horizontal mounting at air pressure  
0.5 Mpa [73 psi.]

1 mm/s = 0.0394 in./sec.  
1 kg = 2.205 lb.

## Replacing the shock absorber

The WT slide table is equipped with shock absorbers as standard equipment. A ring wrench is needed for replacing the shock absorber, and prepare it in advance.

### ● Removing

- ① Using a ring wrench, turn the hex-head portion on the shock absorber body and loosen the shock absorber.
- ② Turn the body thread of the shock absorber until it comes off, and pull it out of the tapped hole.

### ● Mounting

- ① Thread the shock absorber until the hex-head portion of the body contacts the tapped hole of the table. (Remove any hexagon nuts which have been already attached to the shock absorber)
- ② Tighten the hex-head portion on the shock absorber body with the ring wrench, and secure it.

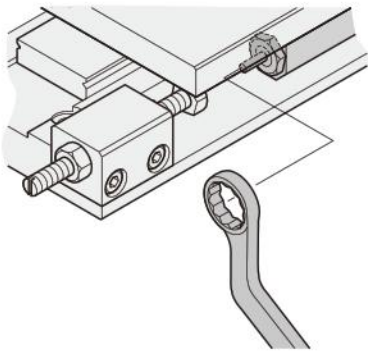

## Tightening torque of the shock absorber

Model	Tightening torque N·cm [in·lbf]	Width across flats of the hex-head mm [in.]
AWT16 (KSHA6×8-E-X)	637 [56]	12 [0.472]
AWT20 (KSHA7×8-G-X)	1177 [104]	14 [0.551]

Remark: For securing the shock absorber, tighten the hex-head portion using the above values as references.

- Cautions:**
1. Adjust it so that the stopper bolt on the main body and the shock absorber make full contact.
  2. Use the shock absorber within the range of the absorption capacity of the shock absorber (refers to shock absorber capacity graph). Note that the absorption energy of the shock absorber is different in a low-speed range than that in a high-speed range.
  3. The impact maximum speed of the shock absorber is 1000mm/s [39.4in./sec.]. The speed when it just collides must not exceed 1000mm/s [39.4in./sec.] since it differs from the average speed. Moreover, consult us when it exceeds 1000mm/s [39.4in./sec.].
  4. Do not use the shock absorber in a place where water or oil drips. If using it in these places, install a cover, etc., so the drops do not hit it directly. This could lead to improper operation and may decrease the absorption capacity.
  5. Do not loosen the small screw on the rear end of the shock absorber. The oil inside will leak out which will fail the function of the shock absorber.
  6. Do not install other shock absorbers in this product without permission. When other shock absorbers are used, damage to the cylinder, etc., may occur.

## Calculation of impact energy

Horizontal impact	
$E = E_1 + E_2$ $= \frac{m \cdot v^2}{2} + F \cdot L$	$E' = E_1 + E_2$ $= \frac{W' \cdot v'^2}{2g'} + F' \cdot L'$

Vertical impact <sup>Note1</sup>	
When descending <sup>Note2</sup>	
$E = E_1 + E_2 + E_3$ $= \frac{m \cdot v^2}{2} + F \cdot L + m \cdot g \cdot L$	$E' = E_1 + E_2 + E_3$ $= \frac{W' \cdot v'^2}{2g'} + F' \cdot L' + W' \cdot L'$
When ascending	
$E = E_1 + E_2 - E_3$ $= \frac{m \cdot v^2}{2} + F \cdot L - m \cdot g \cdot L$	$E' = E_1 + E_2 - E_3$ $= \frac{W' \cdot v'^2}{2g'} + F' \cdot L' - W' \cdot L'$

Note 1: For impact on incline,  $E_3$  becomes  $E_3' = m \cdot g \cdot L \cdot \sin \theta$ .

Note 1: For impact on incline,  $E_3$  becomes  $E_3' = W' \cdot L' \cdot \sin \theta$ .

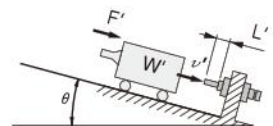
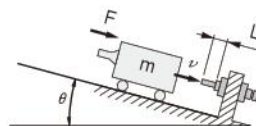

Note 2: When descending, the operating air pressure: P, should be lower than when ascending, because heavier loads can be carried.

$E$  : Total impact energy...[J]  
 $E_1$  : Kinetic energy...  $\frac{m \cdot v^2}{2}$  [J]  
 $E_2$  : Additional energy by cylinder thrust...  $F \cdot L$  [J]  
 $E_3$  : Additional energy by load...  $m \cdot g \cdot L$  [J]  
 $m$  : Load mass [kg]  
 $v$  : Impact speed [m/s]  
 $g$  : Gravity acceleration 9.8 [m/s<sup>2</sup>]  
 $F$  : Cylinder thrust...  $= \frac{\pi}{4} \cdot D^2 \cdot P$  [N]  
 [D: cylinder bore (mm); P: operating air pressure (Mpa)]  
 $L$  : Absorbing stroke of shock absorber [m]

$E'$  : Total impact energy...[ft·lbf]  
 $E_1$  : Kinetic energy...  $\frac{W' \cdot v'^2}{2g'}$  [ft·lbf]  
 $E_2$  : Additional energy by cylinder thrust...  $F' \cdot L'$  [ft·lbf]  
 $E_3$  : Additional energy by load weight...  $W' \cdot L'$  [ft·lbf]  
 $W'$  : Load weight [lbf.]  
 $v'$  : Impact speed [ft./sec.]  
 $g'$  : Gravity acceleration 32.2 [ft./sec.<sup>2</sup>]  
 $F'$  : Cylinder thrust...  $= \frac{\pi}{4} \cdot D'^2 \cdot P'$  [lbf.]  
 [D': cylinder bore [in.]; P': operating air pressure [psi.]]  
 $L'$  : Absorbing stroke of shock absorber [ft.]

## Dimensions of Shock Absorber (mm)

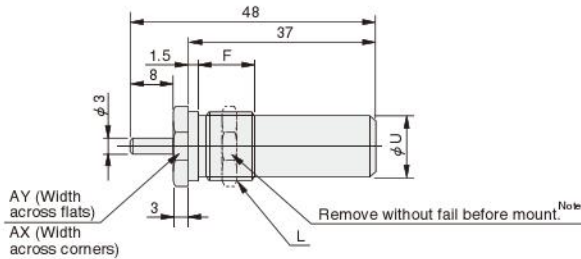

Note: Additional shock absorbers have this nut, but the nut must be removed before use.

Model	Code	F	L	U	AX	AY
KSHA6	×8-E-X	10.5	M10×1	8.5	13.9	12
KSHA7	×8-G-X	12.5	M12×1	10.5	16.2	14

### Mounting

1. While any mounting direction of the WT slide table is allowed, the mounting surface should always be flat. Twisting or bending during mounting may disturb the accuracy and may also result in air leaks or improper operation.
2. Caution should be exercised that scratches or dents on the WT slide table's mounting surface may damage its flatness.
3. Take locking device or anti-looseness measures when shocks or vibrations might loosen the bolts.

#### ● Installation by using female threads on the body bottom

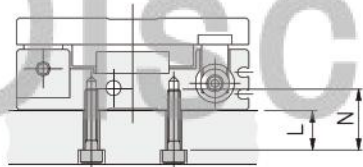

#### ● Installation by using through holes on the body

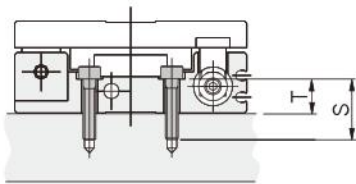

#### Mounting bolt screw length (as a guide)

Model	N mm [in.]	T mm [in.]	S mm [in.]	Mounting bolt
AWT16	L+9 [0.35]	14 [0.55]	25 [0.98]	M6×1
AWT20	L+12 [0.47]	16 [0.63]	30 [1.18]	M8×1.25

#### Mounting bolt tightening torque (as a guide)

Model	Tightening torque N·cm [in·lbf]	Mounting bolt
AWT16	800 [71]	M6×1
AWT20	2000 [177]	M8×1.25

Remark: Refer to the above values when tightening the bolts.

### Stroke adjustment

The stroke of the WT slide table can be adjusted by changing the mounting position of the stopper bolt; up to -32mm [-1.26in.] on one side, -64mm [-2.52in.] for both sides with the **AWT16**, and up to -29mm [-1.14in.] on one side, -58mm [-2.28in.] for both sides with the **AWT20**.

#### ● Stroke adjustment

up to -13mm [-0.51in.] on one side with the **AWT16**

up to -10mm [-0.39in.] on one side with the **AWT20**

- ① Loosen the hexagon nut which is securing the stopper bolt.
- ② Adjust the position of the stopper bolt by turning the minus groove of the stopper bolt with a flat-blade screw driver.
- ③ Tighten and secure the hexagon nut when the position is determined.

#### ● Stroke adjustment

-13~-32mm [-0.51~-1.26in.] range on one side with the **AWT16**

-10~-29mm [-0.39~-1.14in.] range on one side with the **AWT20**

- ① Remove the mounting bolt which is securing the block.
- ② Move the block from 'A' to 'B' and secure it by tightening the mounting bolt.
- ③ Then, finely adjust the stopper bolt by using the method described above: "stroke adjustment up to -13mm [-0.51in.] on one side with the **AWT16** and up to -10mm [-0.39in.] on one side with the **AWT20**."

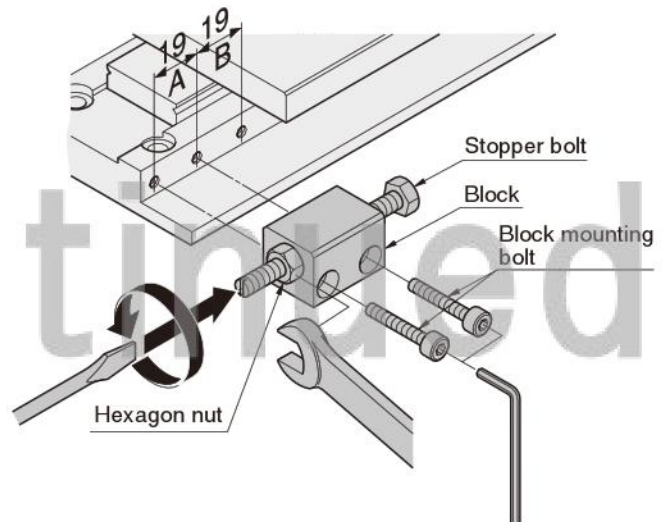

#### Tightening torque of the bolt and nut

Parts	Tightening torque N·cm [in·lbf]	Width across flats mm [in.]
Block mounting bolt ( <b>AWT16</b> )	500[44]	4 [0.157]
Block mounting bolt ( <b>AWT20</b> )	800 [71]	5 [0.197]
Hexagon nut	800 [71]	10 [0.394]

Remark: Refer to the above values when tightening the bolts.

**Caution:** Use the WT slide table with the specified stroke or below. Moreover, do not remove the stopper bolt. Using more than the specified stroke or with the stopper bolt removed causes damage.

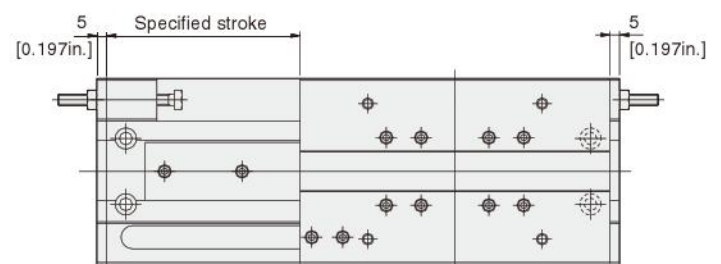

# WT SLIDE TABLES



## Specifications

Item	Model	AWT16	AWT20
Bore size	mm [in.]	16 [0.630]	20 [0.787]
Operation type		Double acting type	
Media		Air	
Operating pressure range	MPa [psi.]	0.15~0.7 [22~102]	
Proof pressure	MPa [psi.]	1.03 [149]	
Operating temperature range	°C [°F]	0~60 [32~140]	
Operating speed range	mm/s [in./sec.]	100~500 [3.9~19.7]	
Cushion		Shock absorber (Standard equipment)	
Lubrication	Cylinder portion	Not required (If lubrication is required, use Turbine Oil Class 1 [ISO VG32] or equivalent.)	
	Guide portion	Required (Lithium soap-based grease) <sup>Note</sup>	
Stroke adjusting range	mm [in.]	-64~0 [-2.52~0] (To the specified stroke, one side MAX. -32 [-1.26], both sides MAX. -64 [-2.52])	-58~0 [-2.28~0] (To the specified stroke, one side MAX. -29 [-1.14], both sides MAX. -58 [-2.28])
Repeatability	mm [in.]	±0.05 [±0.002]	
Maximum load capacity	N [lbf.]	150 [33.7]	200 [45.0]
Allowable static load	N [lbf.]	6000 [1349]	7000 [1574]
Port size	Rc	1/8	

Note: Apply lithium soap-based grease on the raceway surface of the track rail every 6 months or every 300km [186mi.] of traveling distance.

## Shock Absorber Specifications

Item	Model	KSHA6×8-E-X	KSHA7×8-G-X
Applicable type		AWT16	AWT20
Maximum absorption	J [ft·lbf]	2.0 [1.5]	3.9 [2.9]
Absorbing stroke	mm [in.]	8 [0.315]	
Maximum impact speed	mm/s [in./sec.]	1000 [39.4]	
Maximum operating frequency	cycle/min	30	
Spring return force (When retracted)	N [lbf.]	9.8 [2.2]	
Angle variation		3° or less	
Operating temperature range	°C [°F]	0~60 [32~140]	

Note: The life of the shock absorber may vary from the WT slide table, depending on its operating conditions.

## Bore Size and Stroke

Bore size	Standard strokes		Maximum available stroke
	mm		mm
16	50, 100, 150, 200		200
20			

## Mass

Model	Stroke mm				Additional mass of sensor switch <sup>Note</sup>	
	50	100	150	200	ZE□□□A	ZE□□□B
AWT16	1.9 [4.2]	2.2 [4.9]	2.8 [6.2]	3.4 [7.5]	0.015 [0.033]	0.035 [0.077]
AWT20	2.75 [6.06]	3.1 [6.8]	4.0 [8.8]	4.8 [10.6]		

Note: Sensor switch types A and B show the lead wire lengths.  
A:1000mm [39in.] B:3000mm [118in.]

## Order Codes

**AWT** **16 × 200** - [ ] [ ] [ ]

**Alpha series**  
WT slide table

**Bore size**  
×  
**Stroke**

**Number of sensor switches**  
1 : With 1 sensor switch  
2 : With 2 sensor switches  
3 : With 3 sensor switches  
⋮

**Lead wire length**  
**A** : 1000mm [39in.]  
**B** : 3000mm [118in.]

**Sensor switch**  
**Blank**: No sensor switch  
**ZE101**: Reed switch type without indicator lamp Horizontal lead wire DC5~28V, AC85~115V  
**ZE102**: Reed switch type with indicator lamp Horizontal lead wire DC10~28V, AC85~115V  
**ZE201**: Reed switch type without indicator lamp Vertical lead wire<sup>Note</sup> DC5~28V, AC85~115V  
**ZE202**: Reed switch type with indicator lamp Vertical lead wire<sup>Note</sup> DC10~28V, AC85~115V  
**ZE135**: 2-lead wire Solid state type with indicator lamp Horizontal lead wire DC10~28V  
**ZE155**: 3-lead wire Solid state type with indicator lamp Horizontal lead wire DC4.5~28V  
**ZE235**: 2-lead wire Solid state type with indicator lamp Vertical lead wire<sup>Note</sup> DC10~28V  
**ZE255**: 3-lead wire Solid state type with indicator lamp Vertical lead wire<sup>Note</sup> DC4.5~28V

Note: In the vertical lead wire type, the lead wire protrudes at right angles to the sensor switch.  
● For details of sensor switches, see p.1544.

## Additional parts

### ● Shock absorber

**KSHA6 × 8-E-X** (For AWT16)

**KSHA7 × 8-G-X** (For AWT20)

### ● Sensor switch

For the order code of sensor switches, see p.1028.

## Cylinder Thrust

Select a suitable cylinder bore size considering the load and air pressure to obtain the required thrust.

Since the figures in the table are calculated values, select a bore size that results in a load ratio (load ratio =  $\frac{\text{Load}}{\text{Calculated value}}$ ) of 70% or less (50% or less for high speed application).

Bore size mm [in.]	Rod diameter mm [in.]	Operation	Pressure area mm <sup>2</sup> [in. <sup>2</sup> ]	Air pressure MPa [psi.]						
				0.2 [29]	0.3 [44]	0.4 [58]	0.5 [73]	0.6 [87]	0.7 [102]	
<b>16 [0.630]</b>	8 [0.315]	Double acting type	Push side	201.0 [0.3116]	40.2 [9.04]	60.3 [13.56]	80.4 [18.07]	100.5 [22.59]	120.6 [27.11]	140.7 [31.63]
			Pull side	150.0 [0.2325]	30.1 [6.77]	45.2 [10.16]	60.3 [13.56]	75.4 [16.95]	90.4 [20.32]	105.5 [23.72]
<b>20 [0.787]</b>	10 [0.394]	Double acting type	Push side	314.0 [0.4867]	62.8 [14.12]	94.2 [21.18]	125.6 [28.23]	157.0 [35.29]	188.4 [42.35]	219.8 [49.41]
			Pull side	235.5 [0.3650]	47.1 [10.59]	70.7 [15.89]	94.2 [21.18]	117.8 [26.48]	141.3 [31.76]	164.9 [37.07]

## Connection Port and Moving Direction of the Table

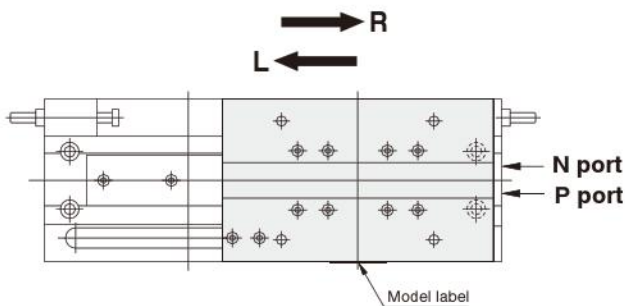

- The table moves in the direction of **R** when air is supplied to **N port**.
- The table moves in the direction of **L** when air is supplied to **P port**.

# Inner Construction

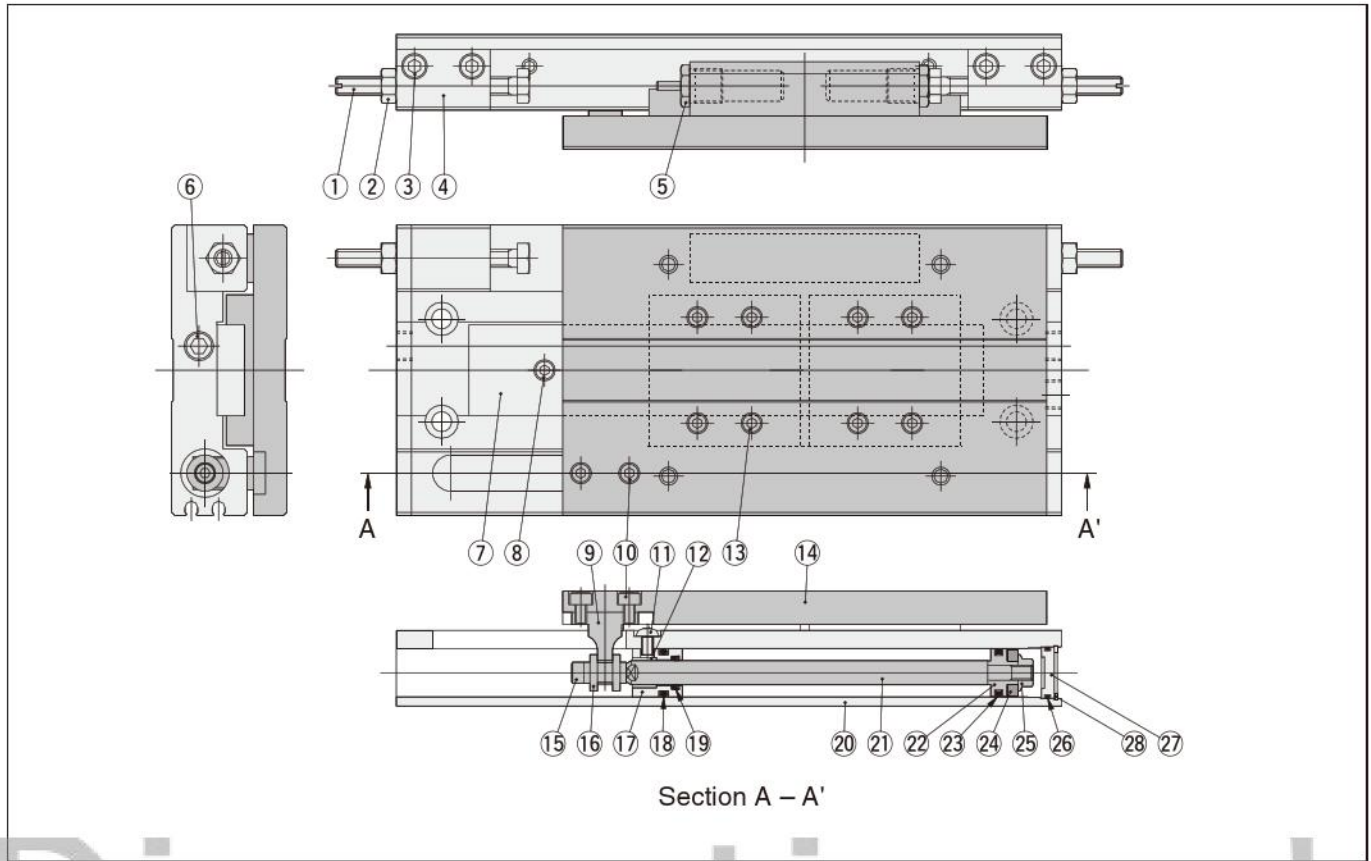

# Discontinued

## Major Parts and Materials

No.	Parts	Materials	Q'ty	Remarks
①	Stopper bolt	Steel	2	Nickel plated
②	Hexagon nut	Stainless steel	2	
③	Hexagon socket head bolt	Stainless steel	4	
④	Block	Aluminum alloy	2	Anodized
⑤	Shock absorber	—	2	
⑥	Plug	Alloy steel	1	Zinc plated
⑦	Linear guide	—	1	
⑧	Hexagon socket head bolt	Stainless steel	—	
⑨	Connected pin	Steel	1	Nickel plated
⑩	Hexagon socket head bolt	Stainless steel	2	
⑪	Hexagon socket button head screw	Alloy steel	1	Nickel plated
⑫	Bushing	Steel and copper alloy	1	
⑬	Hexagon socket head bolt	Stainless steel	8	
⑭	Table	Aluminum alloy	1	Anodized

No.	Parts	Materials	Q'ty	Remarks
⑮	Hexagon socket head bolt	Stainless steel	1	
⑯	Sleeve	Stainless steel	1	
⑰	Housing	Aluminum alloy	1	Special rust prevention treatment
⑱	O-ring	Synthetic rubber (NBR)	1	
⑲	Rod seal	Synthetic rubber (NBR)	1	
⑳	Main body	Aluminum alloy	1	Anodized
㉑	Piston rod	Stainless steel	1	Chrome plated
㉒	Piston	Aluminum alloy	1	Special rust prevention treatment
㉓	Piston seal	Synthetic rubber (NBR)	1	
㉔	Magnet	Plastic magnet	1	
㉕	Hexagon nut with flange	Stainless steel	1	
㉖	O-ring	Synthetic rubber (NBR)	1	
㉗	End plate	Plastic	1	
㉘	Snap ring	Spring steel	1	Nickel plated

Dimensions of WT Slide Table AWT16 (mm)



● AWT16 × Stroke

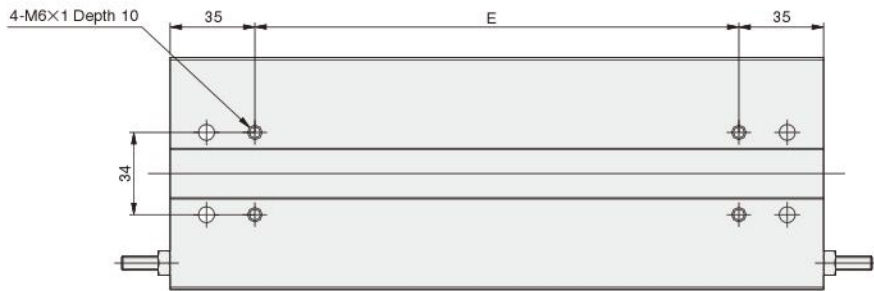
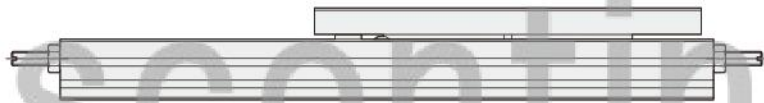
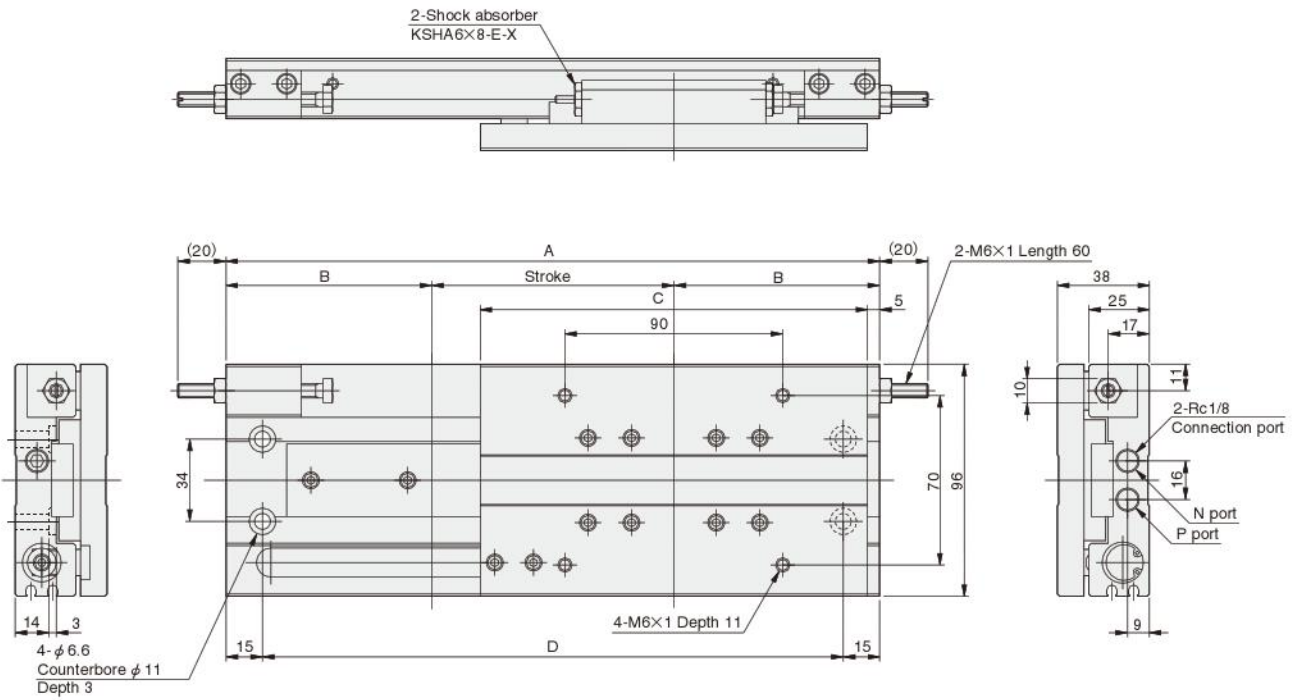

Stroke	A	B	C	D	E
50	220	85	160	190	150
100	270	85	160	240	200
150	370	110	210	340	300
200	470	135	260	440	400

WT SLIDE TABLES

Dimensions of WT Slide Table AWT20 (mm)



● AWT20 × Stroke

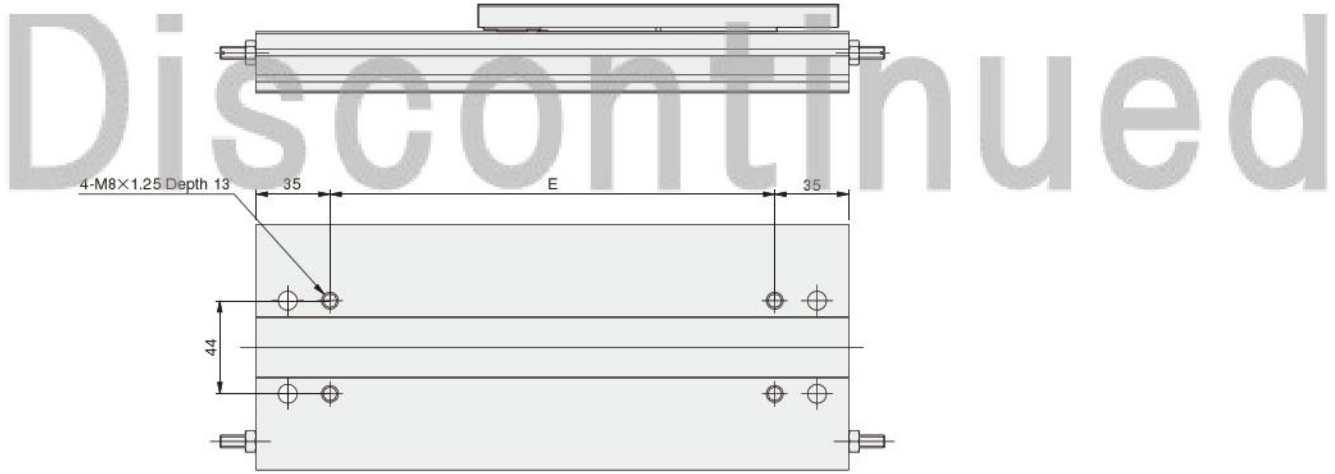
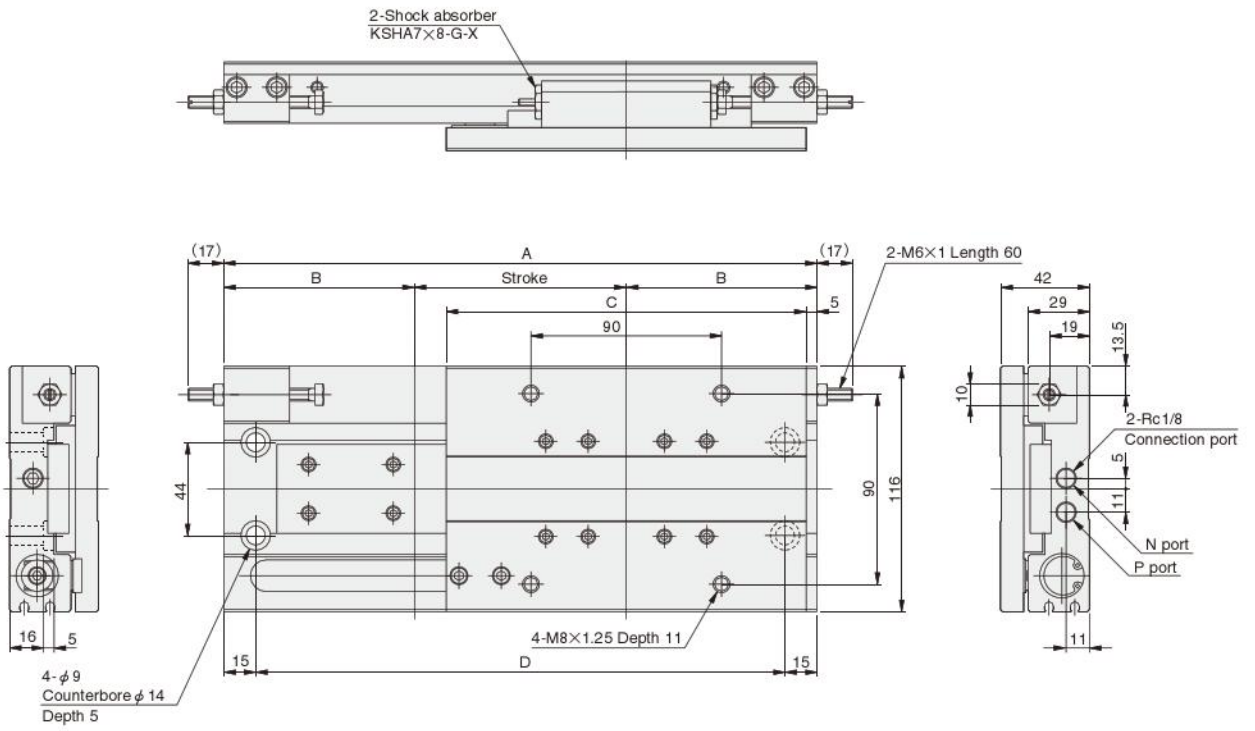

Discontinued

Stroke	A	B	C	D	E
50	230	90	170	200	160
100	280	90	170	250	210
150	380	115	220	350	310
200	480	140	270	450	410

# SENSOR SWITCHES

Solid State Type, Reed Switch Type



## Order Codes



**Lead wire length**  
**A** — 1000mm [39in.]  
**B** — 3000mm [118in.]

### Sensor switch

**ZE135** — Solid state type with indicator lamp DC10V~28V Horizontal lead wire  
**ZE235** — Solid state type with indicator lamp DC10V~28V Vertical lead wire  
**ZE101** — Reed switch type without indicator lamp DC5V~28V AC85~115V Horizontal lead wire  
**ZE201** — Reed switch type without indicator lamp DC5V~28V AC85~115V Vertical lead wire

● For details of sensor switches, see p.1544.

**ZE155** — Solid state type with indicator lamp DC4.5V~28V Horizontal lead wire  
**ZE255** — Solid state type with indicator lamp DC4.5V~28V Vertical lead wire  
**ZE102** — Reed switch type with indicator lamp DC10V~28V AC85~115V Horizontal lead wire  
**ZE202** — Reed switch type with indicator lamp DC10V~28V AC85~115V Vertical lead wire

## Minimum Cylinder Strokes When Using Sensor Switches

Bore size	Solid state type		Reed switch type	
	2 pcs. mounting	1 pc. mounting	2 pcs. mounting	1 pc. mounting
16 [0.630]	10	5	10	10
20 [0.787]				

mm [in.]

## Moving Sensor Switch

- Loosening the mounting screw allows the sensor switch to be moved along the switch mounting groove of the body.
- Tighten the mounting screw with a tightening torque of 0.1~0.2N·m [0.9~1.8in·lbf].

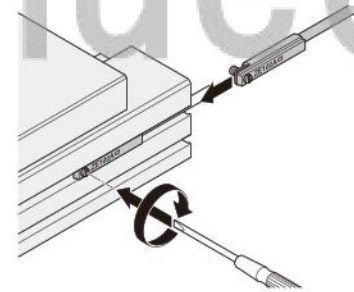

## Sensor Switch Operating Range, Response Differential, and Maximum Sensing Location

### ● Operating range : $\ell$

The distance the piston travels in one direction, while the switch is in the ON position.

### ● Response differential : C

The distance between the point where the piston turns the switch ON and the point where the switch is turned OFF as the piston travels in the opposite direction.

### ● Solid state type

Item	Bore size	16 [0.630]	20 [0.787]
Operating range: $\ell$		2~5 [0.079~0.197]	3.5~7.5 [0.138~0.295]
Response differential: C		1.0 [0.039] or less	
Maximum sensing location <sup>Note</sup>		6 [0.236]	

Remark: The above table shows reference values.

Note: This is the length measured from the switch's opposite end side to the lead wire.

### ● Reed switch type

Item	Bore size	16 [0.630]	20 [0.787]
Operating range: $\ell$		6.5~9 [0.256~0.354]	10~13 [0.394~0.512]
Response differential: C		1.5 [0.059] or less	
Maximum sensing location <sup>Note</sup>		10 [0.394]	

Remark: The above table shows reference values.

Note: This is the length measured from the switch's opposite end side to the lead wire.

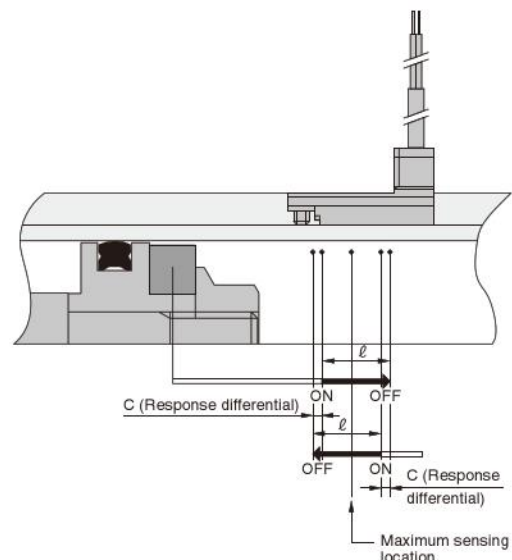

## Mounting Location of End of Stroke Detection Sensor Switch

- When the sensor switch is mounted in the locations shown below (the figures in the tables are reference values), the magnet comes to the maximum sensing location of the sensor switch at the end of the stroke.

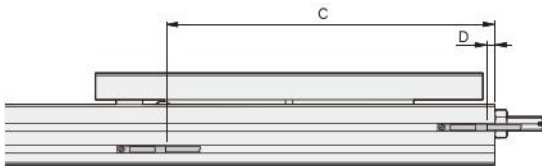

### ● Solid state type

mm [in.]

Model	Code	A	B	C	D
AWT16	×50	60.5 [2.382]	10.5 [0.413]	57 [2.244]	7 [0.276]
	×100	110.5 [4.350]		107 [4.213]	
	×150	160.5 [6.319]		157 [6.181]	
	×200	210.5 [8.287]		207 [8.150]	
AWT20	×50	64 [2.520]	14 [0.551]	60.5 [2.382]	10.5 [0.413]
	×100	114 [4.488]		110.5 [4.350]	
	×150	164 [6.457]		160.5 [6.319]	
	×200	214 [8.425]		210.5 [8.287]	

### ● Reed switch type

mm [in.]

Model	Code	A	B	C	D
AWT16	×50	56.5 [2.224]	6.5 [0.256]	54 [2.126]	4 [0.157]
	×100	106.5 [4.193]		104 [4.094]	
	×150	156.5 [6.161]		154 [6.063]	
	×200	206.5 [8.130]		204 [8.031]	
AWT20	×50	60 [2.362]	10 [0.394]	57.5 [2.264]	7.5 [0.295]
	×100	110 [4.331]		107.5 [4.232]	
	×150	160 [6.299]		157.5 [6.201]	
	×200	210 [8.268]		207.5 [8.169]	

## When Mounting WT Slide Tables with Sensor Switches in Close Proximity

- When mounting WT slide tables with sensor switches in close proximity, install the WT slide tables so that they should not be below the values shown in the following tables.

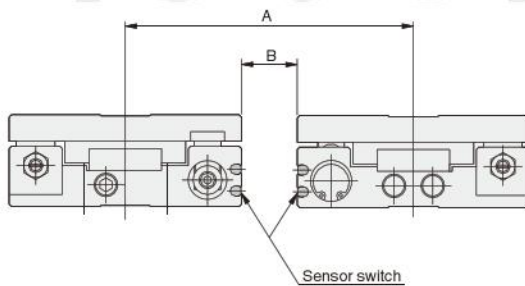

### ● Solid state type

mm [in.]

Model	Code	A	B
AWT16		106 [4.17]	10 [0.39]
AWT20		126 [4.96]	10 [0.39]

### ● Reed switch type

mm [in.]

Model	Code	A	B
AWT16		101 [3.98]	5 [0.20]
AWT20		121 [4.76]	5 [0.20]