

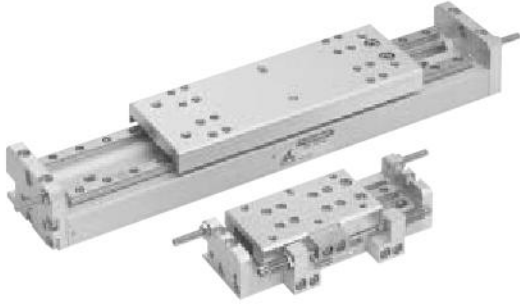

CAD drawing data catalog
is available.



KOGANEI

ACTUATORS GENERAL CATALOG



alpha series

WS SLIDE TABLES INDEX

Features	901
Safety Precautions, Handling Instructions and Precautions	903
Specifications	907
Order Code	908
Inner Construction, Major Parts and Materials	909
Dimensions	910
Sensor Switches	915

WS SLIDE TABLES

Discontinued



Caution

Before use, be sure to read the "Safety Precautions" on p. 45.

The slide table now features a new style, complete series!

■ Cylinder thrust (Operating pressure 0.5MPa, push side) ^{Note 1}

AWS6: 28N [6.3lbf.], AWS10: 78.5N [17.6lbf.],
 AWS16: 201N [45.2lbf.], AWS20: 314N [70.6lbf.],
 AWS25: 490.5N [110.3lbf.]

● Pitching ^{Note 2}

Allowable bending moment
 AWS6 × 50: 4N·m [3.0ft·lbf]
 AWS10 × 100: 16N·m [11.8ft·lbf]
 AWS16 × 100: 17N·m [12.5ft·lbf]
 AWS20 × 100: 30N·m [22.1ft·lbf]
 AWS25 × 100: 42N·m [31.0ft·lbf]

● Yawing ^{Note 2}

Allowable bending moment
 AWS6 × 50: 4N·m [3.0ft·lbf]
 AWS10 × 100: 16N·m [11.8ft·lbf]
 AWS16 × 100: 17N·m [12.5ft·lbf]
 AWS20 × 100: 30N·m [22.1ft·lbf]
 AWS25 × 100: 42N·m [31.0ft·lbf]

Notes: 1. For details of cylinder thrust, see p.907.
 2. For details of allowable bending moment, see p.904.

■ Two guides for high rigidity (One guide for $\phi 6$ [0.236in.])

Rigidity-emphasizing design uses two linear guides to achieve a large allowable moment.

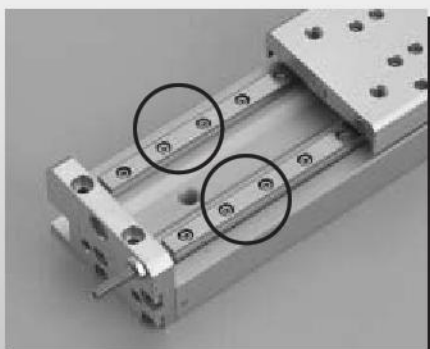

■ Twin rod for high thrust

Use of a twin rod cylinder obtains double the thrust of conventional cylinders, and combines with the two guides to achieve high load transfer in the vertical direction.

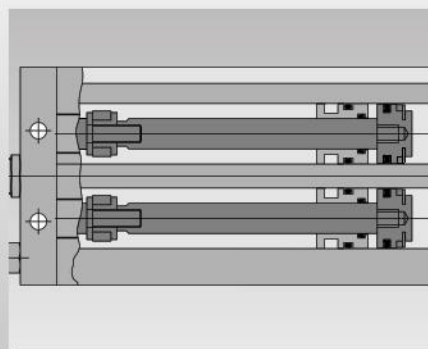

■ Locating dowel pin holes & Heli-sert inserted mounting threads

The locating dowel pin holes have been prepared to improve repeatability of mounting and dismounting. Moreover, the mounting threads with heli-serts for strength available.

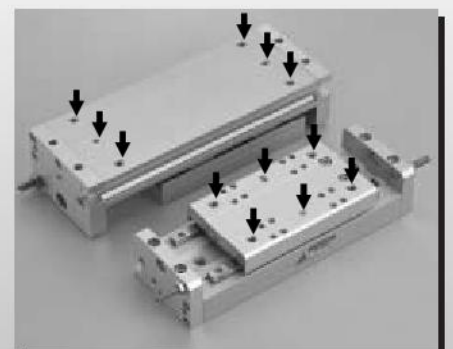

High thrust (Twin rod)+ High rigidity (Two guides) Note: For $\phi 6$ [0.236in.], one guide.

for a more

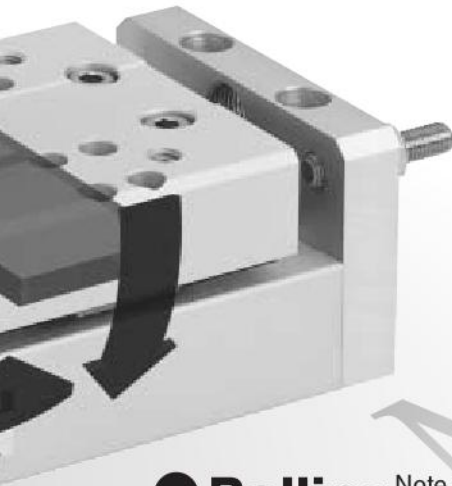

● Rolling Note 2

- Allowable bending moment
- AWS6: 1N·m [0.7ft·lbf]
 - AWS10: 7N·m [5.2ft·lbf]
 - AWS16: 9N·m [6.6ft·lbf]
 - AWS20: 16N·m [11.8ft·lbf]
 - AWS25: 20N·m [14.8ft·lbf]

Application example

- Application example of requiring high thrust in Z axis.

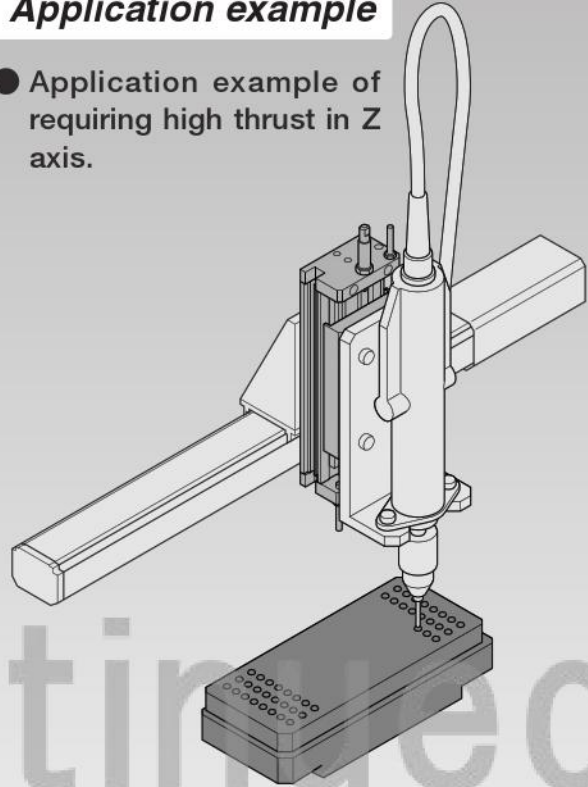

WS SLIDE TABLES

■ With shock absorber (Optional)

A fixed absorption capacity type shock absorber that improves repeatability at the end of the stroke, and reduces shocks and noise, is optional.

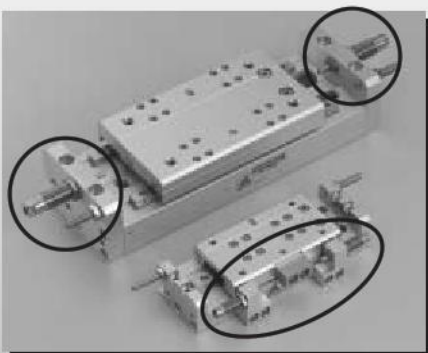

■ Embedded type sensor switch and piping ports at one body end

Embedded type sensor switch does not protrude from the body. In addition, concentration of all piping ports at one body end allows wiring and piping connections in a single direction.

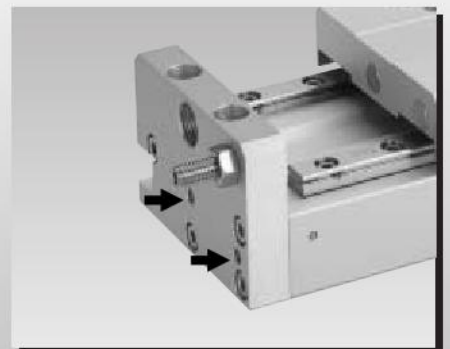
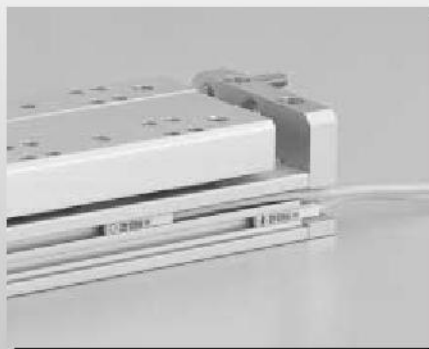

* Sensor switch is optional.

Safety Precautions (WS Slide Table)

Warning

Listed below are safety precautions specifically for the WS Slide Table. For general safety precautions, be sure to read p.45.

- Do not put your fingers into the space between the side plate and the table. Because fingers could be trapped between the side plate and the table during operation, never put your fingers into the gap. Actuator's thrust is large, and serious personal injury could occur.

Handling Instructions and Precautions



General precautions

Piping

1. Always thoroughly blow off (use compressed air) the tubing before connecting it to the WS slide table. Entering chips, sealing tape, rust, etc., generated during piping work could result in air leaks or other defective operation.
2. When screwing piping or fittings into the WS slide table, tighten to the appropriate tightening torque shown below.

Bore size mm [in.]	Connecting thread	Tightening torque N·cm (kgf·cm) [in·lbf]
6 [0.236]	M3×0.5	59 {6} [5.2]
10 [0.394]	M5×0.8	157 {16} [13.9]
16 [0.630]		
20 [0.787]		
25 [0.984]		

Media

1. Use air for the media. For the use of any other media, consult us.
2. Air used for the cylinder should be clean air that contains no deteriorated compressor oil, etc. Install an air filter (filtration of 40 μm or less) near the cylinder or valve to remove collected liquid or dust. In addition, drain the air filter periodically. Collected liquid or dust entering the cylinder may cause improper operation.

Lubrication

1. The product can be used without lubrication, if lubrication is required, use Turbine Oil Class 1 (ISO VG32) or equivalent. Avoid using spindle oil or machine oil.
2. Apply lithium soap-based grease on the raceway surface of the track rail in the guide portion every 6 months or every 300km [186mi.] of traveling distance.

Atmosphere

If using in locations subject to dripping water, dripping oil, etc., or to large amounts of dust, use a cover to protect the unit.

Discontinued

Handling Instructions and Precautions



Mounting and adjustment

Allowable load and moment

Although the WS slide table can be used with directly applying load, make sure that the load and moment do not exceed the values in the table below.

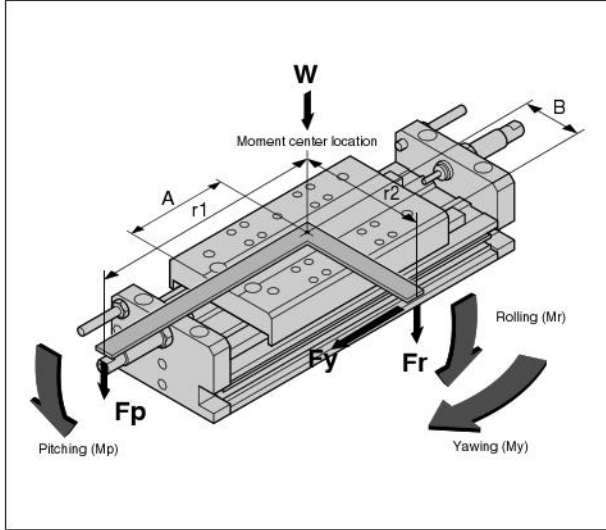

Pitching moment: $M_p = F_p \times r_1$ (N·m)
 Rolling moment: $M_r = F_r \times r_2$ (N·m)
 Yawing moment: $M_y = F_y \times r_2$ (N·m)
 Maximum load capacity: W (N)

Allowable bending moment

Allowable bending moment	Stroke mm	25	50	75	100~150
		M_p (Pitching)	AWS6	2.0 [0.20] [1.5]	4.0 [0.41] [3.0]
M_y (Yawing)	AWS10	—	7.0 [0.71] [5.2]	12.0 [1.22] [8.9]	16.0 [1.63] [11.8]
	AWS16	—	9.0 [0.92] [6.6]	13.0 [1.33] [9.6]	17.0 [1.73] [12.5]
	AWS20	—	15.0 [1.53] [11.1]	23.0 [2.35] [17.0]	30.0 [3.06] [22.1]
	AWS25	—	18.0 [1.84] [13.3]	30.0 [3.06] [22.1]	42.0 [4.28] [31.0]
M_r (Rolling)	AWS6	1.0 [0.10] [0.7]	—	—	—
	AWS10	7.0 [0.71] [5.2]	—	—	—
	AWS16	9.0 [0.92] [6.6]	—	—	—
	AWS20	16.0 [1.63] [11.8]	—	—	—
	AWS25	20.0 [2.04] [14.8]	—	—	—

Note: The allowable bending moment in the rolling direction does not change with the stroke.

Maximum load capacity

Model	W Maximum load capacity	Without shock absorber N [kgf] [lbf.]	With shock absorber N [kgf] [lbf.]
AWS6	—	5 [0.5] [1.1]	15 [1.5] [3.4]
AWS10	—	30 [3.1] [6.7]	50 [5.1] [11.2]
AWS16	—	40 [4.1] [9.0]	80 [8.2] [18.0]
AWS20	—	60 [6.1] [13.5]	120 [12.3] [27.0]
AWS25	—	80 [8.2] [18.0]	200 [20.4] [45.0]

Caution: The moment including the inertial force generated when the load is moved or stopped must not exceed the values in the above table.
 Keep the load and speed within the specification range.

Moment center location

Model	Stroke Code		25		50		75		100		125		150	
	A	B	A	B	A	B	A	B	A	B	A	B	A	B
AWS6	33.5 [1.319]	18 [0.709]	46 [1.811]	18 [0.709]	—	—	—	—	—	—	—	—	—	—
AWS10	—	—	48 [1.890]	25.5 [1.004]	60.5 [2.382]	25.5 [1.004]	73 [2.874]	25.5 [1.004]	—	—	—	—	—	—
AWS16	—	—	53 [2.087]	30.5 [1.201]	65.5 [2.579]	30.5 [1.201]	78 [3.071]	30.5 [1.201]	90.5 [3.563]	30.5 [1.201]	103 [4.055]	30.5 [1.201]	—	—
AWS20	—	—	60.5 [2.382]	36 [1.417]	73 [2.874]	36 [1.417]	85.5 [3.366]	36 [1.417]	98 [3.858]	36 [1.417]	110.5 [4.350]	36 [1.417]	—	—
AWS25	—	—	62 [2.441]	45 [1.772]	74.5 [2.933]	45 [1.772]	87 [3.425]	45 [1.772]	99.5 [3.917]	45 [1.772]	112 [4.409]	45 [1.772]	—	—

Connection Port and Moving Direction of the Table

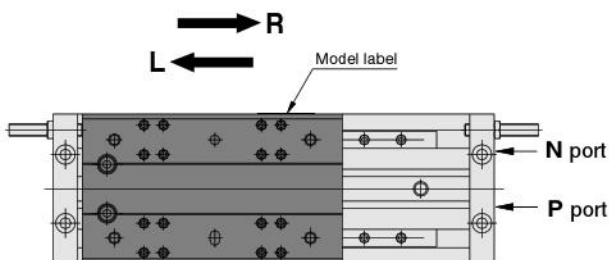

- The table moves in the direction of **R** when air is supplied to **N** port.
- The table moves in the direction of **L** when air is supplied to **P** port.

Plate End Eccentricity (Reference Value)

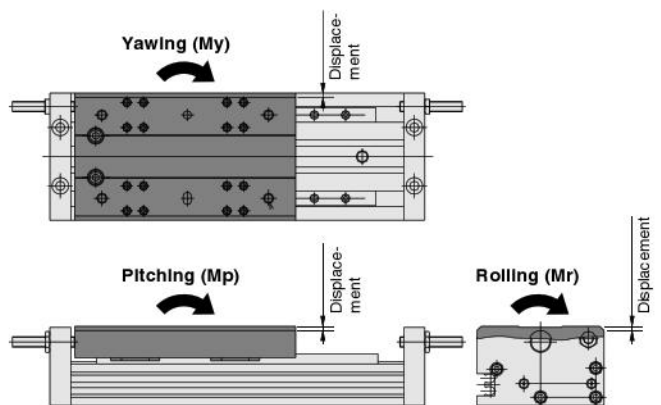

Discontinued

Handling Instructions and Precautions

■ Plate end eccentricity (Reference value)

● AWS6

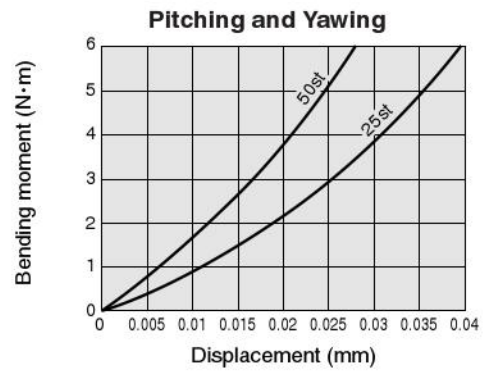
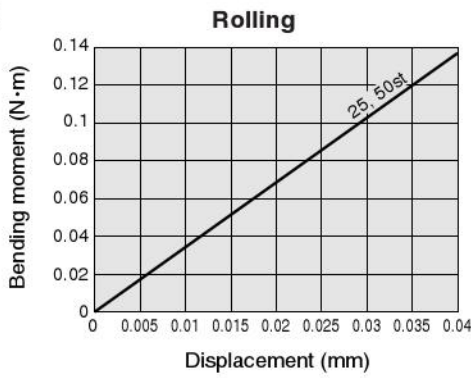

● AWS10

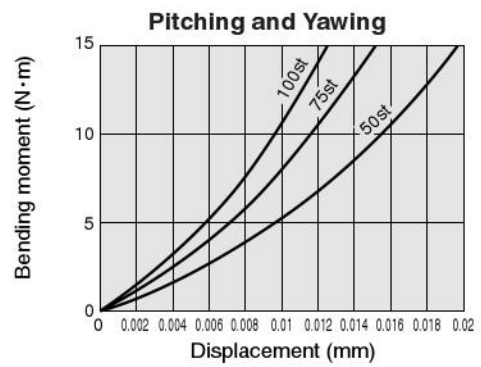
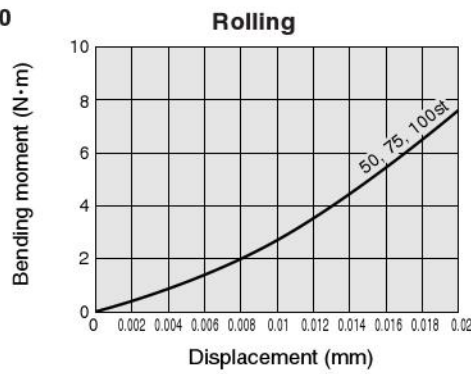

● AWS16

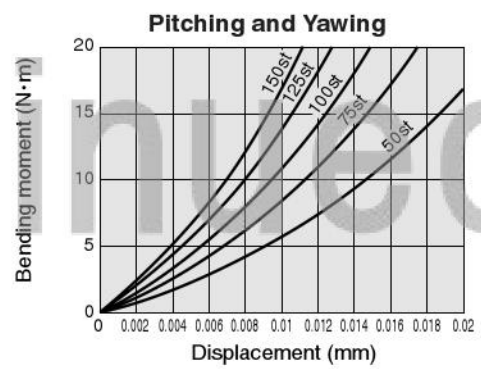
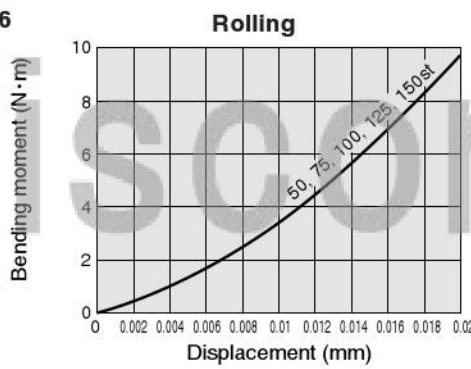

● AWS20

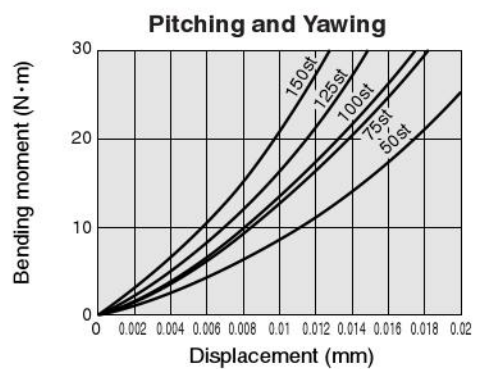
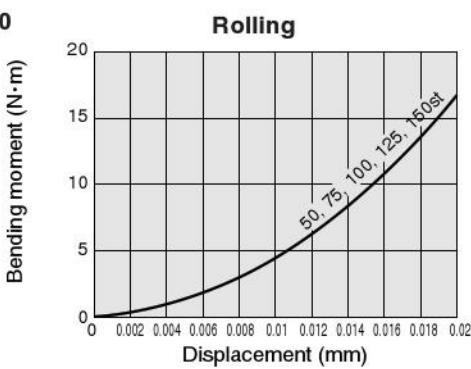

● AWS25

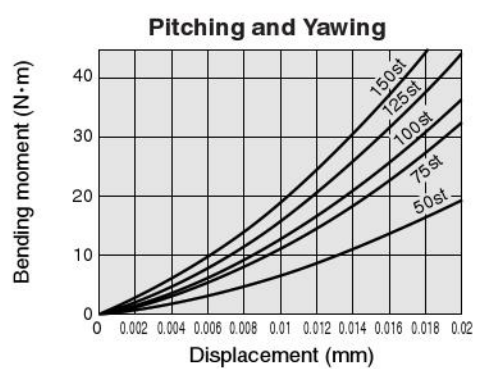
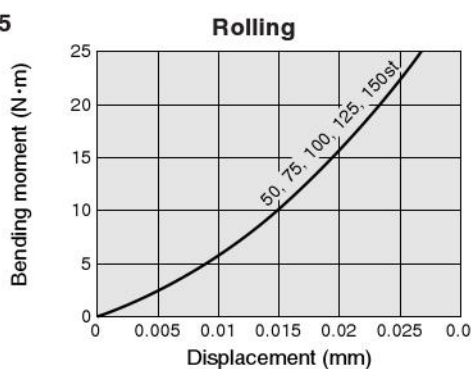

1N·m = 0.7376ft·lbf, 1mm = 0.0394in.



Mounting

Piping

1. If using the WS slide table without the shock absorber, always install an external shock absorbing device.
2. Because the hexagon nut for the stopper bolt is only temporarily tightened at shipping, be sure to tighten and secure it in place at time of use.
3. While any mounting direction of the WS slide table is allowed, mounting surface should always be flat. (Recommended flatness: Within 0.1mm/500mm [0.004in./19.69in.]) Twisting or bending during the mountings may disturb the accuracy and may also result in air leaks or improper operation.
4. Caution should be exercised that scratches or dents on the mounting surface of WS slide table may damage its flatness.
5. Take locking device or anti-looseness measures when shocks or vibrations might loosen the bolts.

Stroke adjustment method

The stroke of the WS slide table can be adjusted by screwed depth of the stopper bolt, as follows:

AWS6, 10 +2~-18mm [+0.08~-0.71in.]
(One side: +1~-9mm [+0.04~-0.35in.]

AWS16 +2~-28mm [+0.08~-1.10in.]
(One side: +1~-14mm [+0.04~-0.55in.]

AWT20, 25 +2~-26mm [+0.08~-1.02in.]
(One side: +1~-13mm [+0.04~-0.51in.]

- ① Loosen the hexagon nut which is securing the stopper bolt.
- ② Adjust the position of the stopper bolt by turning the hexagon socket hole of the stopper bolt with a hexagon bar wrench.
- ③ When the position is determined, secure the hexagon nut in place by tightening it.
- ④ For the slider with shock absorber, adjust the shock absorber position, as well. Keep the clearance between the table and shock absorber within range of 0~0.5mm [0~0.020in.]. Adjustment over 0.5mm [0.020in.] clearance will result in reduction of shock absorbing capacity.

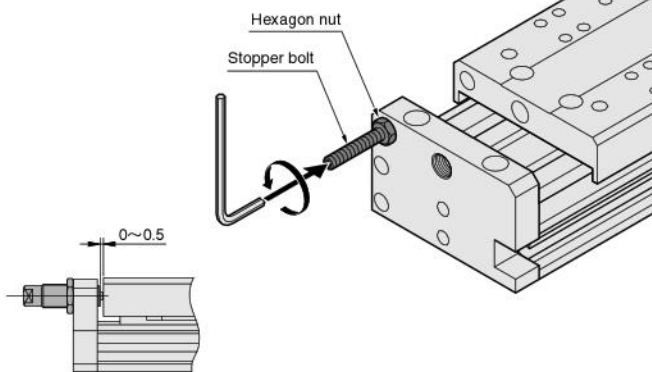

Tighten the hexagon nut for mounting the stopper bolt to the tightening torques shown in the table below. Torques in excess of these values can damage the threads.

Model	Tightening torque N·cm [kgf·cm] [in·lbf]	Mounting nut
AWS6	137 [14] [12.1]	M4×0.7
AWS10	137 [14] [12.1]	M4×0.7
AWS16	284 [29] [25.1]	M5×0.8
AWS20	480 [49] [42.5]	M6×1
AWS25	1196 [122] [105.9]	M8×1.25

Shock absorber absorption capacity

While the shock absorber is a WS slide table's option, do not use the WS slide table in excess of its specifications (maximum operating speed and maximum load capacity) even if they are within the range of shock absorption capacity.

Position adjustment and replacement procedure of shock absorber

1. For shock absorber's installed position adjusting, mounting and removing, use a wrench to fully loosen the mounting nut.
 2. Turn the shock absorber to adjust the position. For replacement, loosen the body thread until it comes off, then screw the new shock absorber.
 3. When the position is determined, tighten the nut and secure the shock absorber.
 4. If mounting a shock absorber after purchasing WS slide table without it, only **AWS6** requires the bracket set **SS-AWS6** (including a bracket, block, and mounting bolts). For **AWS10, 16, 20, and 25**, the shock absorber can be mounted directly onto the unit.
- Tighten the mounting bolt with a tightening torque of 78N·cm [8kgf·cm] [6.9in·lbf].

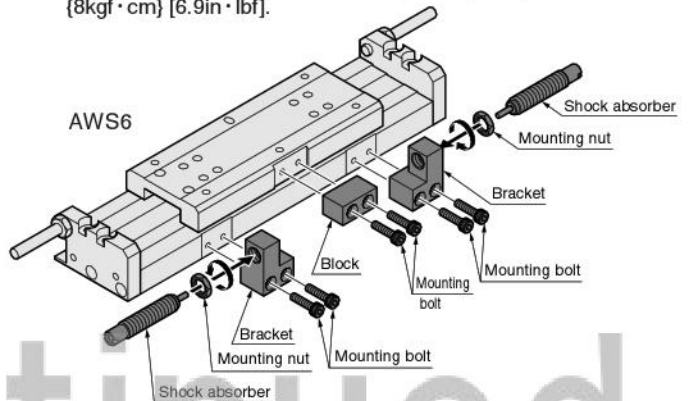

Note: For units with shock absorbers, do not remove the mounting bolt because it is secured in place by an anaerobic adhesive for locking. Removing the bolt could result in damage.

**AWS10, AWS16,
AWS20, AWS25**

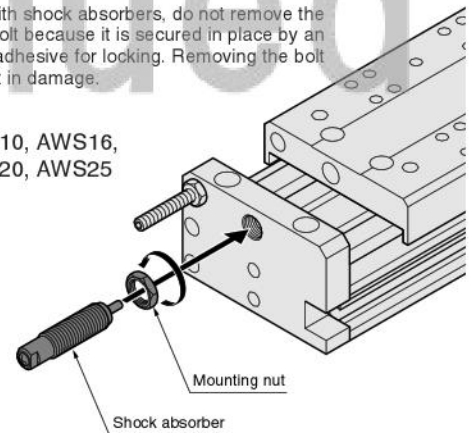

Fasten the hexagon nut for mounting shock absorber in place to the tightening torques shown in the table below. Torques in excess of these values can damage the threads.

Model	Tightening torque N·cm [kgf·cm] [in·lbf]	Width across flats of mounting nut mm [in.]
AWS6	85 [8.7] [7.5]	8 [0.315]
AWS10	245 [25] [21.7]	10 [0.394]
AWS16	637 [65] [56.4]	12 [0.472]
AWS20	1177 [120] [104.2]	14 [0.551]
AWS25	1177 [120] [104.2]	14 [0.551]

- Cautions:**
1. Do not use the shock absorber in a place where water or oil drips. If using it in these places, install a cover, etc. so that water or oil does not splash it directly. This could lead to improper operation and may reduce the absorption capacity.
 2. Do not loosen the small screw on the rear end of the shock absorber. The oil inside will leak out which will fail the function of the shock absorber.
 3. Do not install other shock absorbers in this product without permission. When other shock absorbers are used, damage to the cylinder, etc., may occur.

WS SLIDE TABLES

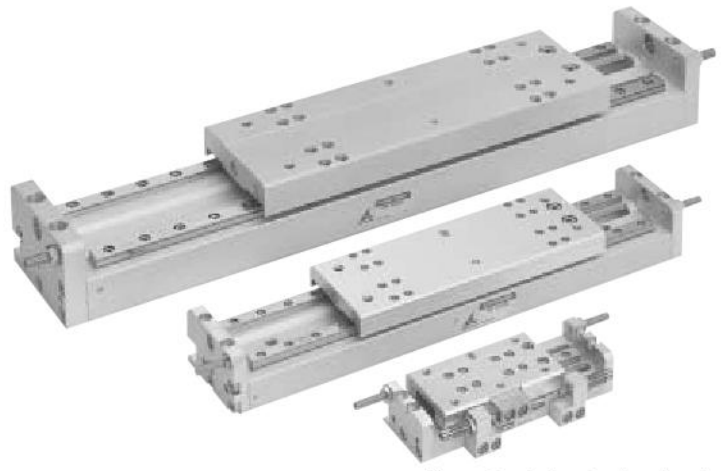

Note: Shock absorber is optional.

Specifications

Item	Model	AWS6	AWS10	AWS16	AWS20	AWS25
Bore size	mm [in.]	6 [0.236]	10 [0.394]	16 [0.630]	20 [0.787]	25 [0.984]
Operating type		Double Acting Type				
Media		Air				
Operating pressure range	MPa {kgf/cm ² } [psi.]	0.2~0.7 [2~7.1] [29~102]				
Proof pressure	MPa {kgf/cm ² } [psi.]	1.05 [10.7] [152]				
Operating temperature range	°C [°F]	0~60 [32~140]				
Operating speed range	mm/s [in./sec.]	150~300 [5.9~11.8] (150~500 [5.9~19.7]) ^{Note 1}		100~300 [3.9~11.8] (100~500 [3.9~19.7]) ^{Note 1}		
Cushion		Shock absorber (Optional)				
Lubrication	Cylinder portion	Not required (If lubrication is required, use Turbine Oil Class 1 [ISO VG32] or equivalent.)				
	Guide portion	Required (Lithium soap-based grease) ^{Note 2}				
Repeatability	mm [in.]	±0.02 [±0.0008]				
Traveling parallelism	mm [in.]	0.1/100 stroke [0.004/3.94 stroke]				
Stroke adjusting range	mm [in.]	+2~-18 [+0.079~-0.709]		+2~-28 [+0.079~-1.102]	+2~-26 [+0.079~-1.024]	
Guide type ^{Note 3}		1 unit of LWL 7		2 units of LWL 7		2 units of LWL 9
Maximum load capacity	Without shock absorber	5 [0.5] [1.1]		30 [3.1] [6.7]		40 [4.1] [9.0]
	With shock absorber	15 [1.5] [3.4]		50 [5.1] [11.2]		80 [8.2] [18.0]
Port size		M3×0.5		M5×0.8		

Notes: 1. Figures in parentheses () are for values when the optional shock absorber is used.

2. Apply lithium soap-based grease on the raceway surface of track rail every 6 months or every 300km [186mi.] of traveling distance.

3. The guide manufacturer is Nippon Thompson Co., Ltd. The guide specifications may be changed without notice.

Shock Absorber Specifications

Item	Model	KSHA4×4-BD	KSHA5×5-E	KSHA6×8-F	KSHA7×8-G	KSHA7×8-K
Applicable model		AWS6	AWS10	AWS16	AWS20	AWS25
Maximum absorption	J {kgf·m} [ft·lbf]	0.5 {0.05} [0.37]	2.0 {0.2} [1.48]	2.9 {0.3} [2.14]	3.9 {0.4} [2.88]	5.9 {0.6} [4.35]
Absorbing stroke	mm [in.]	4 [0.157]	5 [0.197]		8 [0.315]	
Maximum impact speed	m/s [ft./sec.]	1.0 [3.28]				
Maximum operating frequency	cycle/min	60			30	
Spring return force	N {kgf} [lbf.]	3.0 {0.31} [0.67]	6.0 {0.61} [1.35]		8.5 {0.87} [1.91]	
Angle variation		1° or less			3° or less	
Operating temperature range	°C [°F]	0~60 [32~140]				

Note: Do not exceed the WS slide table maximum load capacity and maximum speed, even when they are within the shock absorber's absorption capacity.

Remarks: 1. Do not loosen the small screw on the rear end of the shock absorber. The oil inside will leak out which will fail the function of the shock absorber.

2. Life of shock absorber may vary from the WS slide table, depending on its operating conditions.

3. For details of shock absorber, see Catalog No. BKUA001 "General Catalog of Air Treatment, Auxiliary, Vacuum."

Cylinder Thrust

Select a suitable cylinder bore size considering the load and air pressure to obtain the required thrust.

Since the figures in the table are calculated values, select a bore size that results in a load ratio (load ratio = $\frac{\text{Load}}{\text{Calculated value}}$) of 70% or less (50% or less for high speed application).

Bore size mm [in.]	Piston rod diameter mm [in.]	Operation direction	Pressure area mm ² [in. ²]	Air pressure MPa [psi.]					
				0.2 [29]	0.3 [44]	0.4 [58]	0.5 [73]	0.6 [87]	0.7 [102]
6 [0.236]	4 [0.157]	Push side	56 [0.087]	11.2 [2.52]	16.8 [3.78]	22.4 [5.04]	28.0 [6.29]	33.6 [7.55]	39.2 [8.81]
		Pull side	31 [0.048]	6.2 [1.39]	9.3 [2.09]	12.4 [2.79]	15.5 [3.48]	18.6 [4.18]	21.7 [4.88]
10 [0.394]	5 [0.197]	Push side	157 [0.243]	31.4 [7.06]	47.1 [10.59]	62.8 [14.12]	78.5 [17.65]	94.2 [21.18]	109.9 [24.71]
		Pull side	117 [0.181]	23.4 [5.26]	35.1 [7.89]	46.8 [10.52]	58.5 [13.15]	70.2 [15.78]	81.9 [18.41]
16 [0.630]	8 [0.315]	Push side	402 [0.623]	80.4 [18.07]	120.6 [27.11]	160.8 [36.15]	201.0 [45.18]	241.2 [54.22]	281.4 [63.26]
		Pull side	301 [0.467]	60.2 [13.53]	90.3 [20.30]	120.4 [27.07]	150.5 [33.83]	180.6 [40.60]	210.7 [47.37]
20 [0.787]	10 [0.394]	Push side	628 [0.973]	125.6 [28.23]	188.4 [42.35]	251.2 [56.47]	314.0 [70.59]	376.8 [77.96]	439.6 [98.82]
		Pull side	471 [0.730]	94.2 [21.18]	141.3 [31.76]	188.4 [42.35]	235.5 [52.94]	282.6 [63.53]	329.7 [74.12]
25 [0.984]	10 [0.394]	Push side	981 [1.521]	196.2 [44.11]	294.3 [66.16]	392.4 [88.21]	490.5 [110.26]	588.6 [132.32]	686.7 [154.37]
		Pull side	824 [1.277]	164.8 [37.05]	247.2 [55.57]	329.6 [74.09]	412.0 [92.62]	494.4 [111.14]	576.8 [129.66]

Bore Size and Stroke

			mm
Bore size	Standard strokes	Maximum available stroke	
6	25, 50	50	
10	50, 75, 100	100	
16	50, 75, 100, 125, 150	150	
20			
25			

Order Code

AWS [] - [] - [] [] [] []

Alpha series
WS slide table

Bore size × Stroke

Number of sensor switches
 1 : With one sensor switch
 2 : With two sensor switches
 3 : With three sensor switches
 ⋮

Lead wire length
A : 1000mm [39in.]
B : 3000mm [118in.]

Sensor switch
Blank : Without sensor switch
ZE101 : Reed switch type without indicator lamp
ZE102 : Reed switch type with indicator lamp
ZE201 : Reed switch type without indicator lamp
ZE202 : Reed switch type with indicator lamp
ZE135 : 2-lead wire Solid state type with indicator lamp
ZE155 : 3-lead wire Solid state type with indicator lamp
ZE235 : 2-lead wire Solid state type with indicator lamp
ZE255 : 3-lead wire Solid state type with indicator lamp

Horizontal lead wire DC5~28V, AC85~115V
 Horizontal lead wire DC10~28V, AC85~115V
 Vertical lead wire^{Note} DC5~28V, AC85~115V
 Vertical lead wire^{Note} DC10~28V, AC85~115V
 Horizontal lead wire DC10~28V
 Horizontal lead wire DC4.5~28V
 Vertical lead wire^{Note} DC10~28V
 Vertical lead wire^{Note} DC4.5~28V

Note: In the vertical lead wire type, the lead wire protrudes at right angles to the sensor switch.
 ●For details of sensor switches, see p.1398.

Shock absorber
Blank : Without shock absorber
SS : With shock absorbers

Discontinued

WS SLIDE TABLES

Additional parts

● Shock absorber

- KSHA4×4-BD (For AWS6)^{Note}
- KSHA5×5-E (For AWS10)
- KSHA6×8-F (For AWS16)
- KSHA7×8-G (For AWS20)
- KSHA7×8-K (For AWS25)

Note: If mounting a shock absorber after purchasing the AWS6 without shock absorber, the KSHA4×4-BD shock absorber and the SS-AWS6 bracket set are required. See p.906.

● Sensor switch

For order code of sensor switch, see p.915.

● Bracket set for AWS6^{Note}

SS-AWS6

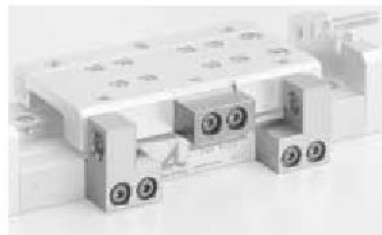

Mass

		g [oz.]					
Bore size mm [in.]	Stroke (mm)	25	50	75	100	125	150
	6 [0.236]		200 [7.05] (238 [8.40])	270 [9.52] (308 [10.86])	—	—	—
10 [0.394]		—	520 [18.34] (534 [18.84])	650 [22.93] (664 [23.42])	780 [27.51] (794 [28.01])	—	—
16 [0.630]		—	820 [28.92] (860 [30.34])	1000 [35.27] (1040 [36.68])	1180 [41.62] (1220 [43.03])	1360 [47.97] (1400 [49.38])	1540 [54.32] (1580 [55.73])
20 [0.787]		—	1350 [47.62] (1406 [49.59])	1610 [56.79] (1666 [58.77])	1870 [65.96] (1926 [67.94])	2130 [75.13] (2186 [77.11])	2390 [84.30] (2446 [86.28])
25 [0.984]		—	2140 [75.49] (2196 [77.46])	2510 [88.54] (2566 [90.51])	2880 [101.59] (2936 [103.56])	3250 [114.64] (3306 [116.61])	3620 [127.69] (3676 [129.66])

Note: Figures in parentheses () show the mass with shock absorber.

Inner Construction

● $\phi 6$

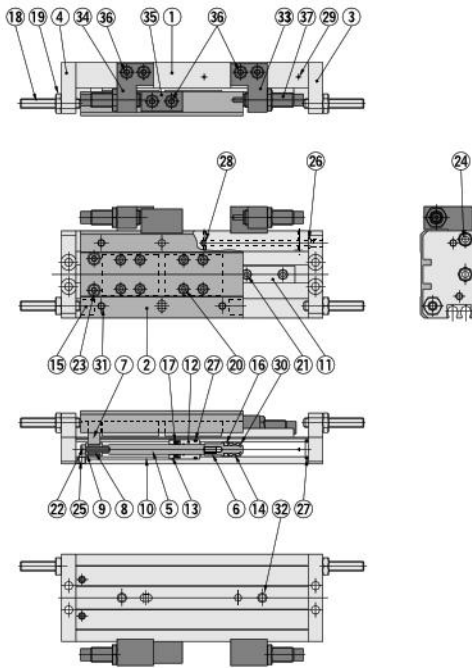

● $\phi 10, \phi 16, \phi 20, \phi 25$

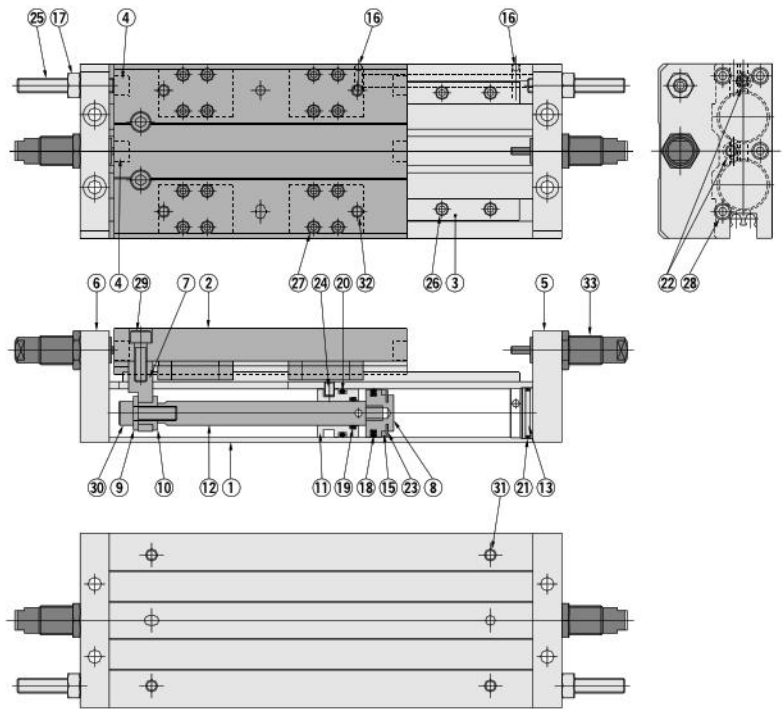

Major Parts and Materials

● $\phi 6$ [0.236in.]

No.	Parts	Materials	Remarks
①	Body	Aluminum alloy (anodized)	
②	Table	Aluminum alloy (anodized)	
③,④	Side plate	Aluminum alloy (anodized)	
⑤	Piston rod	Stainless steel	
⑥	Piston	Brass	
⑦	Connecting plate	Steel (nickel plated)	
⑧	Sleeve	Mild steel (nickel plated)	
⑨	Bolt retainer	Mild steel (nickel plated)	
⑩	Collar	Aluminum alloy (anodized)	
⑪	Linear guide	Stainless steel	
⑫	Housing	Aluminum alloy (anodized)	
⑬	Seal holder	Aluminum alloy (anodized)	
⑭	Magnet	Sintered alloy magnet	
⑮	Pin	Stainless steel (nickel plated)	
⑯	Piston seal	Synthetic rubber (NBR)	
⑰	Rod seal	Synthetic rubber (NBR)	
⑱,⑲	Hexagon socket setscrew	Stainless steel	
⑲	Hexagon nut	Stainless steel	
⑳,㉑,㉒,㉓,㉔,㉕	Hexagon socket head bolt	Stainless steel	
㉖,㉗	O-ring	Synthetic rubber (NBR)	
㉘,㉙	Steel ball	Stainless steel	
㉚	E-ring	Stainless steel	
㉛,㉜	Heli-sert	Stainless steel	
㉝,㉞	Bracket	Aluminum alloy (anodized)	Optional
㉟	Block	Steel (nickel plated)	Optional
㊱	Shock absorber	—	Optional

● $\phi 10$ [0.394in.], $\phi 16$ [0.630in.],
 $\phi 20$ [0.787in.], $\phi 25$ [0.984in.]

No.	Parts	Materials	Remarks
①	Body	Aluminum alloy (anodized)	
②	Table	Aluminum alloy (anodized)	
③	Linear guide	$\phi 10$ [0.394in.], 16 [0.630in.]: Stainless steel, $\phi 20$ [0.787in.], 25 [0.984in.]: Steel	
④	Pin	Stainless steel (nickel plated)	
⑤,⑥	Side plate	Aluminum alloy (anodized)	
⑦	Connecting plate	Steel (nickel plated)	
⑧	Piston	Aluminum alloy (chromic acid anodic oxide coating)	
⑨	Bolt retainer	Mild steel (nickel plated)	
⑩	Sleeve	Mild steel (nickel plated)	
⑪	Housing	Aluminum alloy (anodized)	
⑫	Piston rod	$\phi 10$ [0.394in.]: Stainless steel, $\phi 16, 20, 25$ [0.630in., 0.787in., 0.984in.]: Steel (hard chrome plated)	
⑬	End plate	Plastic	Not available in $\phi 10$, $\phi 16$.
⑮	Magnet	Sintered alloy magnet	
⑯	Steel ball	Stainless steel	
⑰	Hexagon nut	Stainless steel	
⑱	Piston seal	Synthetic rubber (NBR)	
⑲	Rod seal	Synthetic rubber (NBR)	
㉑,㉒,㉓	O-ring	Synthetic rubber (NBR)	
㉔	E-ring	Stainless steel	
㉕,㉖	Hexagon socket setscrew	Stainless steel	
㉗,㉘,㉙,㉚,㉛	Hexagon socket head bolt	Stainless steel	
㉜,㉝	Heli-sert	Stainless steel	
㉞	Shock absorber	—	Optional

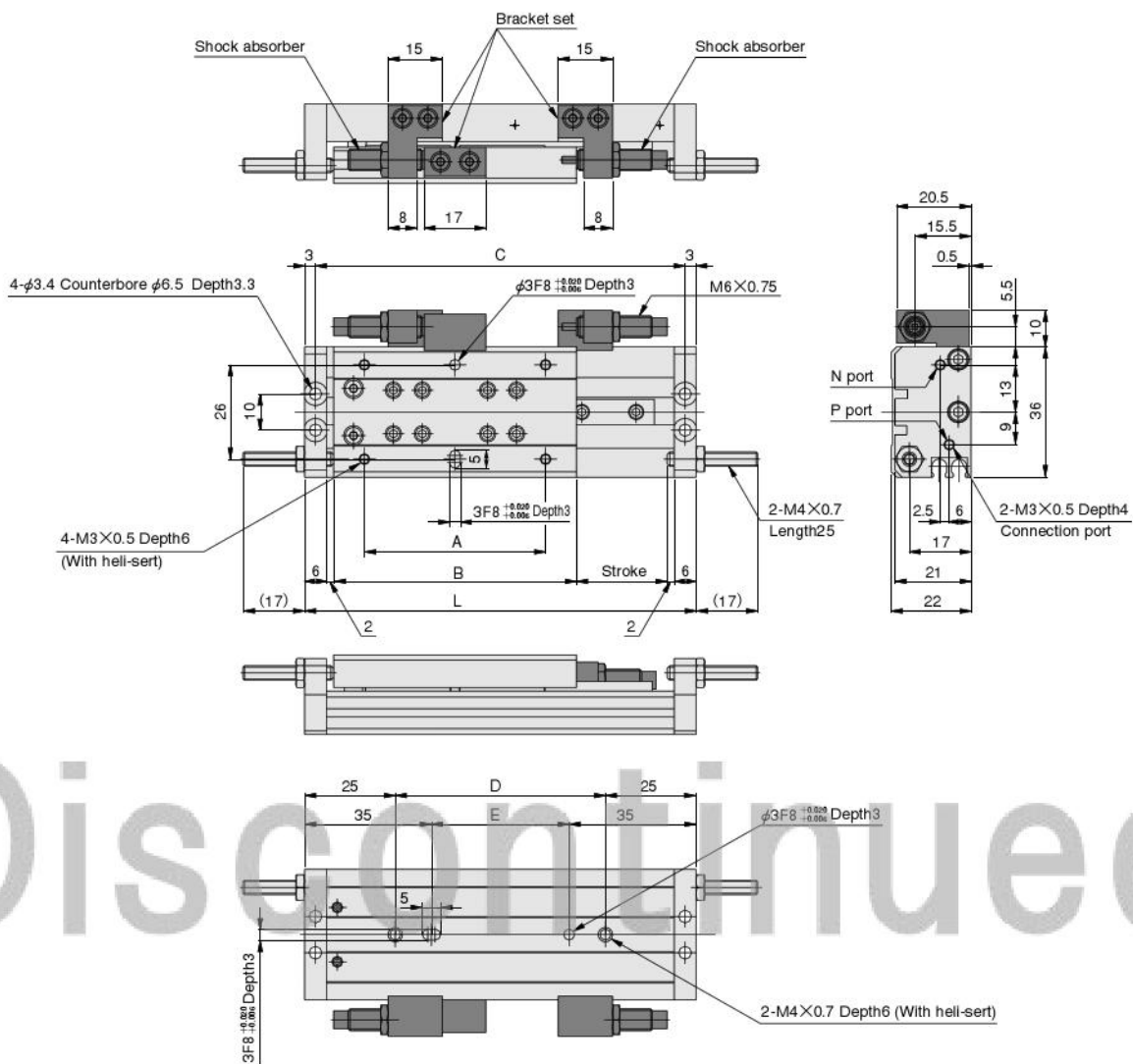

Discontinued

WS SLIDE TABLES

Note: Shock absorbers and bracket set are optional.

Stroke	Code	A	B	C	D	E	L
25		50	67	102	58	38	108
50		75	92	152	108	88	158

Dimensions of Shock Absorber (mm)

●KSHA4 \times 4-BD

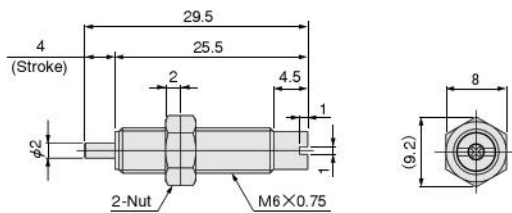

●KSHA \square \times \square

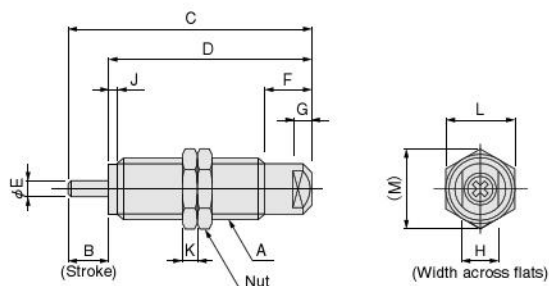

Model	Code	A	B	C	D	E	F	G	H	J	K	L	M
KSHA5 \times 5-E		M8 \times 0.75	5	31	26	2.5	6	3	5	1.2	2	10	11.5
KSHA6 \times 8-F		M10 \times 1	8	48	40	3	10	4	6	2	3	12	13.9
KSHA7 \times 8-G, -K		M12 \times 1	8	48	40	3	10	4	8	2	3	14	16.2

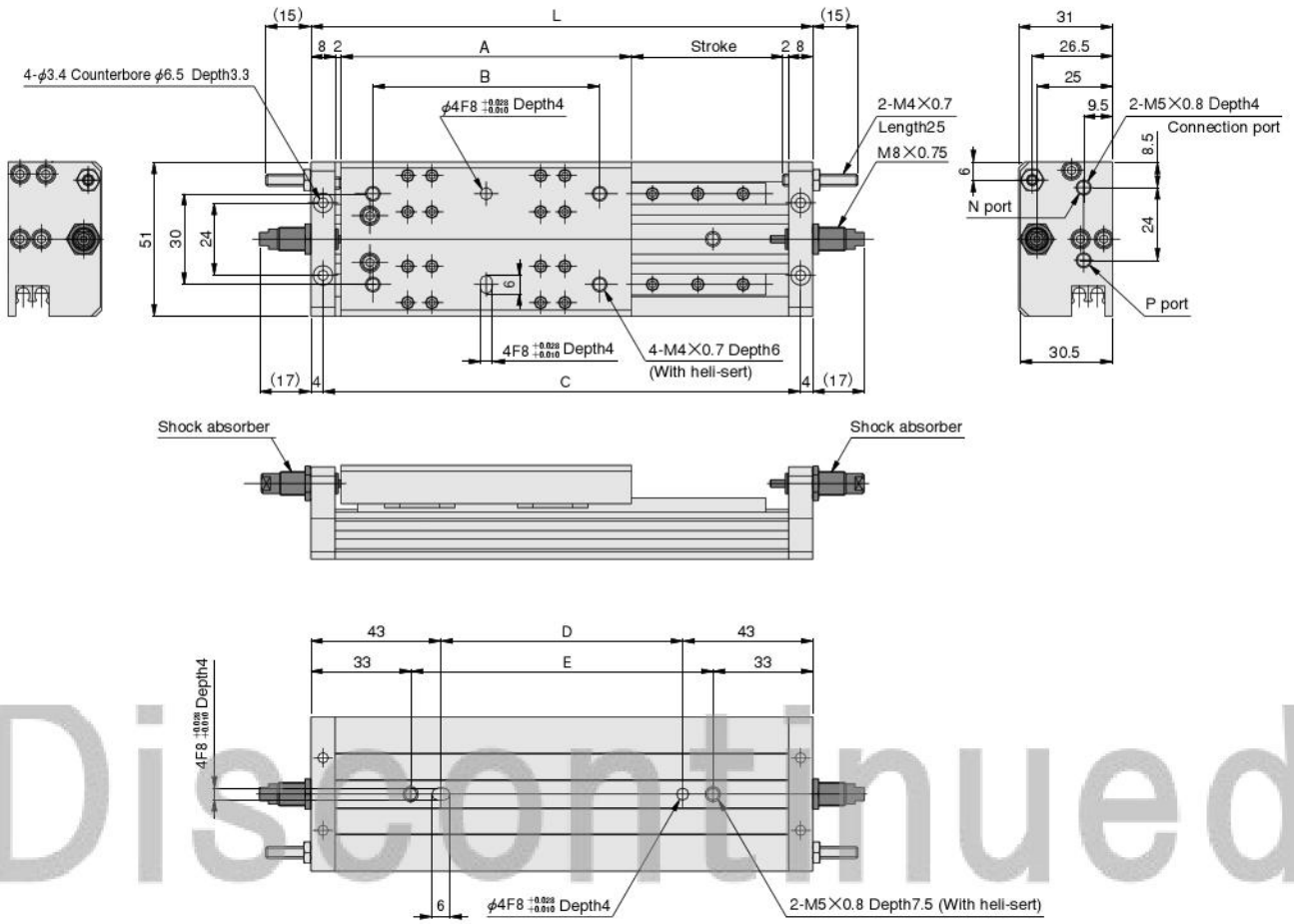

Note: Shock absorbers are optional.

Stroke	Code	A	B	C	D	E	L
50		96	75	158	80	100	166
75		121	100	208	130	150	216
100		146	125	258	180	200	266

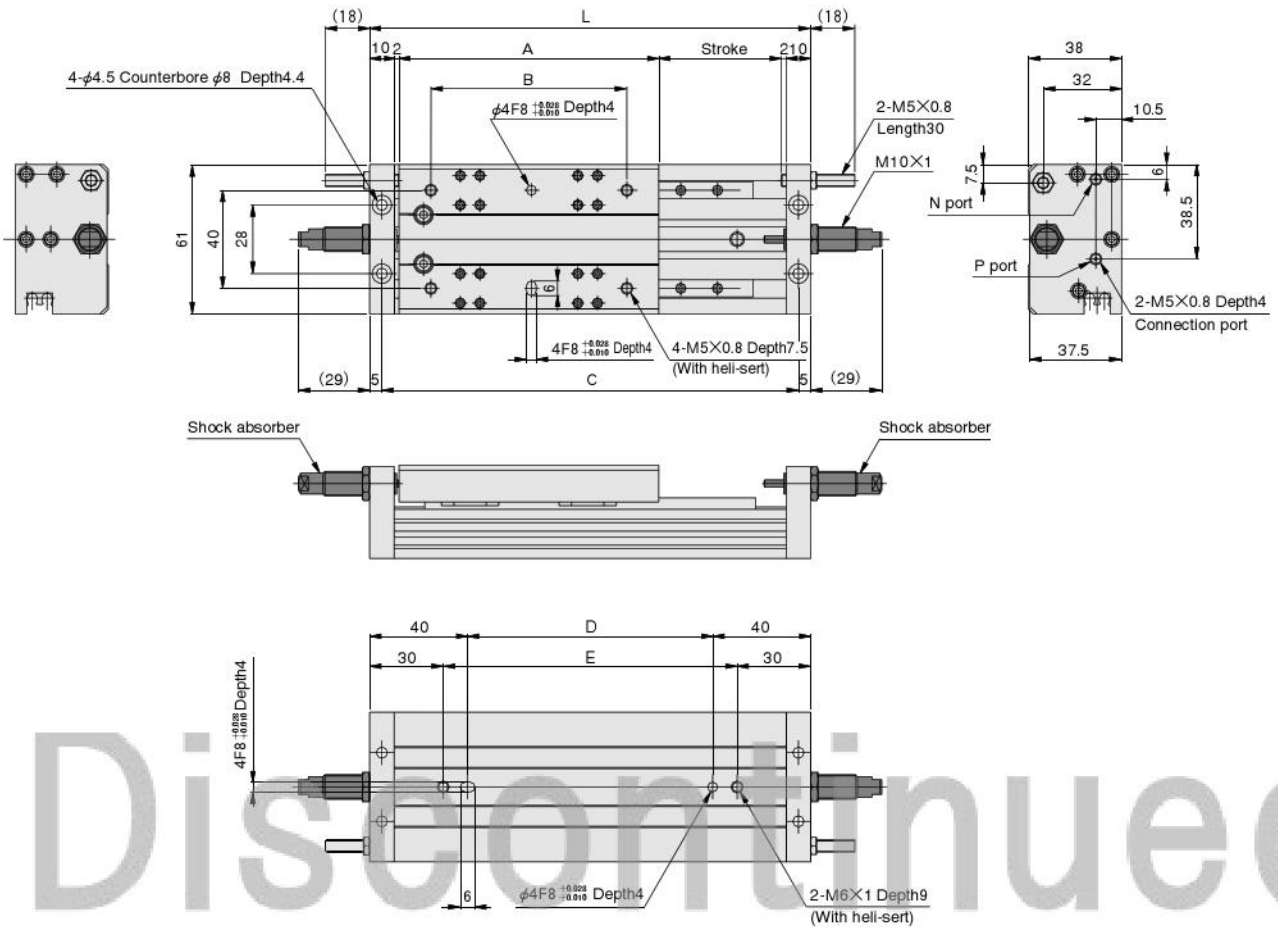

Note: Shock absorbers are optional.

Code	A	B	C	D	E	L
Stroke 50	106	80	170	100	120	180
Stroke 75	131	105	220	150	170	230
Stroke 100	156	130	270	200	220	280
Stroke 125	181	155	320	250	270	330
Stroke 150	206	180	370	300	320	380

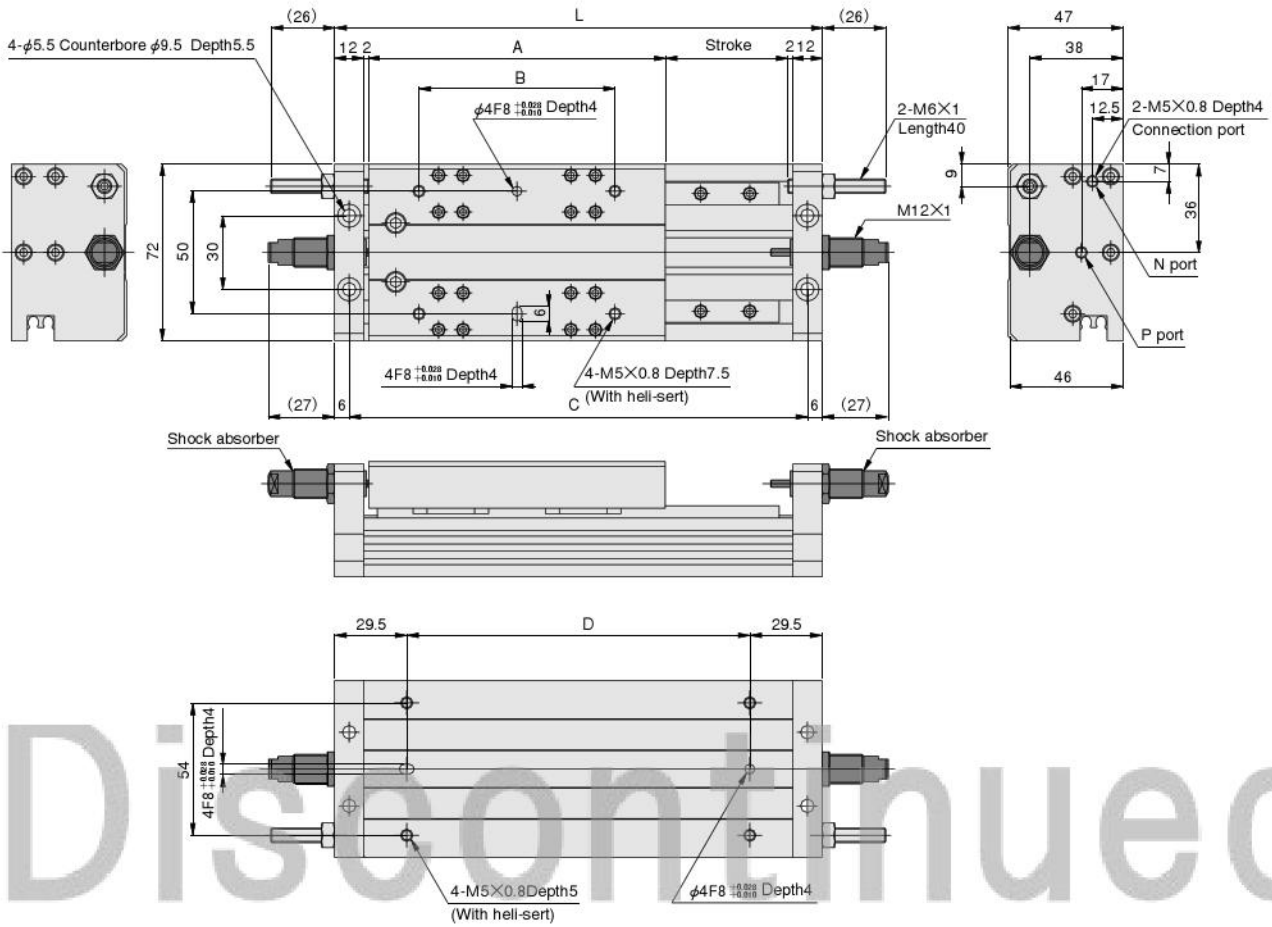

Note: Shock absorbers are optional.

Code	A	B	C	D	L
Stroke 50	121	80	187	140	199
Stroke 75	146	105	237	190	249
Stroke 100	171	130	287	240	299
Stroke 125	196	155	337	290	349
Stroke 150	221	180	387	340	399

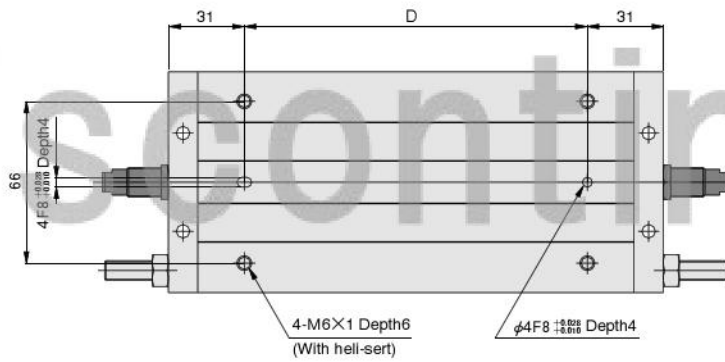
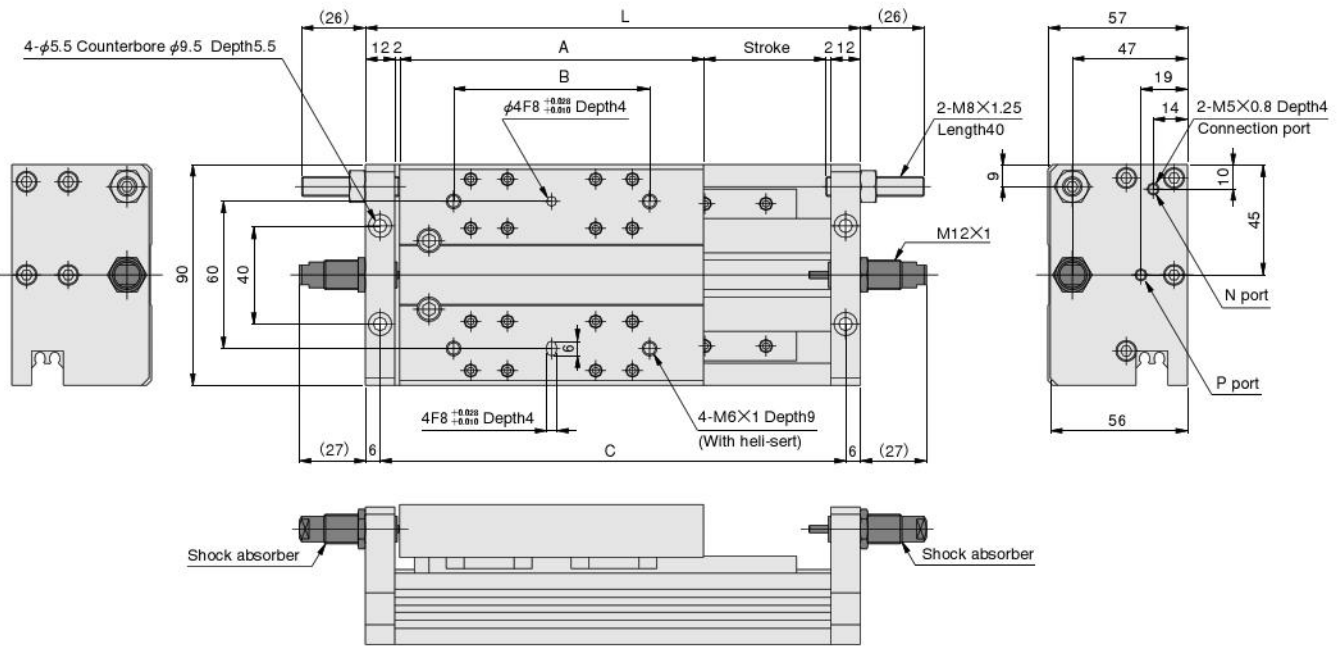

Note: Shock absorbers are optional.

Code	A	B	C	D	L
Stroke 50	124	80	190	140	202
Stroke 75	149	105	240	190	252
Stroke 100	174	130	290	240	302
Stroke 125	199	155	340	290	352
Stroke 150	224	180	390	340	402

SENSOR SWITCHES

Solid State Type, Reed Switch Type

Order Code

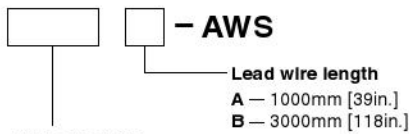

Sensor switch

ZE135 — Solid state type with indicator lamp	DC10~28V	Horizontal lead wire	ZE155 — Solid state type with indicator lamp	DC4.5~28V	Horizontal lead wire
ZE235 — Solid state type with indicator lamp	DC10~28V	Vertical lead wire	ZE255 — Solid state type with indicator lamp	DC4.5~28V	Vertical lead wire
ZE101 — Reed switch type without indicator lamp	DC5~28V AC85~115V	Horizontal lead wire	ZE102 — Reed switch type with indicator lamp	DC10~28V AC85~115V	Horizontal lead wire
ZE201 — Reed switch type without indicator lamp	DC5~28V AC85~115V	Vertical lead wire	ZE202 — Reed switch type with indicator lamp	DC10~28V AC85~115V	Vertical lead wire

● For details of sensor switches, see p.1398.

Moving Sensor Switch

- Loosening the mounting screw allows the sensor switch to be moved along the switch mounting groove on the cylinder body.
- Tighten the mounting screw with a tightening torque of 0.1~0.2N·m {1~2kgf·cm} [0.9~1.8in·lbf].

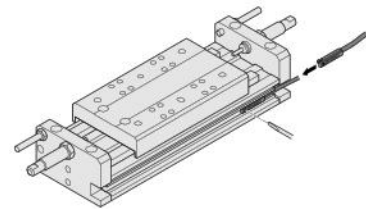

Sensor Switch Operating Range, Response Differential, and Maximum Sensing Location

● Operating range: ℓ

The distance the piston travels in one direction, while the switch is in the ON position.

● Response differential: C

The distance between the point where the piston turns the switch ON and the point where the switch is turned OFF as the piston travels in the opposite direction.

● Solid state type

Item	Bore size	6 [0.236]	10 [0.394]	16 [0.630]	20 [0.787]	25 [0.984]
Operating range: ℓ		2.5~3.5 [0.098~0.138]	2.5~4.0 [0.098~0.157]	2.0~4.5 [0.079~0.177]		2.5~5.5 [0.098~0.217]
Response differential: C		1.0 [0.039] or less		1.2 [0.047] or less		1.5 [0.059] or less
Maximum sensing location ^{Note}		6 [0.236]				

Remark: The above table shows reference values.

Note: It is a value measured from the other end side of the lead wire.

● Reed switch type

Item	Bore size	6 [0.236]	10 [0.394]	16 [0.630]	20 [0.787]	25 [0.984]
Operating range: ℓ		4.5~7.5 [0.177~0.295]	6.5~8.5 [0.256~0.335]	6.0~8.0 [0.236~0.315]		7.0~9.5 [0.276~0.374]
Response differential: C		1.5 [0.059] or less				
Maximum sensing location ^{Note}		10 [0.394]				

Remark: The above table shows reference values.

Note: It is a value measured from the other end side of the lead wire.

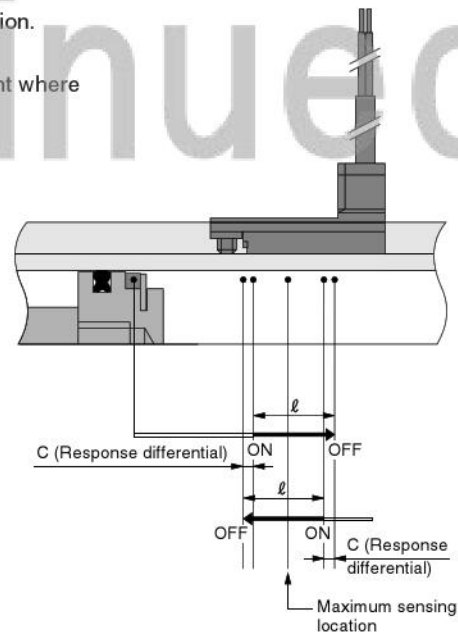

When Mounting the WS Slide Tables with Sensor Switches in Close Proximity

When mounting the WS slide tables with sensor switches in close proximity, install the slide tables so that they should not be below the values shown in the following tables.

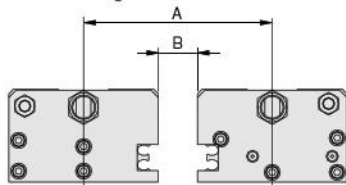

Code	Type	Bore size	6 [0.236]	10 [0.394]	16 [0.630]	20 [0.787]	25 [0.984]
A	Solid state type		44 [1.73]	53 [2.09]	66 [2.60]	73 [2.87]	90 [3.54]
	Reed switch type		44 [1.73]	51 [2.01]	61 [2.40]	72 [2.83]	90 [3.54]
B	Solid state type		8 [0.31]	2 [0.08]	5 [0.20]	1 [0.04]	0
	Reed switch type		8 [0.31]	0	0	0	0

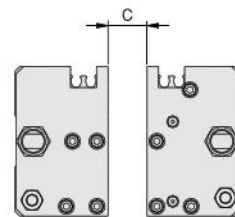

Code	Type	Bore size	6 [0.236]	10 [0.394]	16 [0.630]	20 [0.787]	25 [0.984]
C	Solid state type		8 [0.31]	8 [0.31]	7 [0.28]	4 [0.16]	4 [0.16]
	Reed switch type		8 [0.31]	4 [0.16]	4 [0.16]	4 [0.16]	4 [0.16]

Remark: For mountings other than the above, consult us.

Mounting Location of End of Stroke Detection Sensor Switch

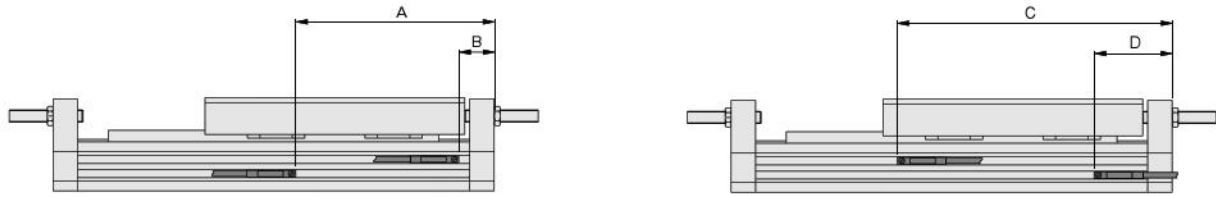

● Solid state type (ZE135, ZE155, ZE235, ZE255)

Model	Stroke	A	B	C	D
AWS6	×25	30.5 [1.201]	— Note	42.5 [1.673]	17.5 [0.689]
	×50	55.5 [2.185]		67.5 [2.657]	
AWS10	×50	57.5 [2.264]	— Note	69.5 [2.736]	19.5 [0.768]
	×75	82.5 [3.248]		94.5 [3.720]	
	×100	107.5 [4.232]		119.5 [4.705]	
AWS16	×50	60.0 [2.362]	— Note	72.0 [2.835]	22.0 [0.866]
	×75	85.0 [3.346]		97.0 [3.819]	
	×100	110.0 [4.331]		122.0 [4.803]	
	×125	135.0 [5.315]		147.0 [5.787]	
AWS20	×50	67.5 [2.657]	17.5 [0.689]	79.5 [3.130]	29.5 [1.161]
	×75	92.5 [3.642]		104.5 [4.114]	
	×100	117.5 [4.626]		129.5 [5.098]	
	×125	142.5 [5.610]		154.5 [6.083]	
	×150	167.5 [6.594]		179.5 [7.067]	
AWS25	×50	68.0 [2.677]	18.0 [0.709]	80.0 [3.150]	30.0 [1.181]
	×75	93.0 [3.661]		105.0 [4.134]	
	×100	118.0 [4.646]		130.0 [5.118]	
	×125	143.0 [5.630]		155.0 [6.102]	
	×150	168.0 [6.614]		180.0 [7.087]	

Note: The sensor switch cannot be secured in place, because its mounting screw position is out of the mounting rail. Do not use in this position.

● Reed switch type (ZE101, ZE102, ZE201, ZE202)

Model	Stroke	A	B	C	D
AWS6	×25	26.5 [1.043]	— Note	46.5 [1.831]	21.5 [0.846]
	×50	51.5 [2.028]		71.5 [2.815]	
AWS10	×50	53.5 [2.106]	— Note	73.5 [2.894]	23.5 [0.925]
	×75	78.5 [3.091]		98.5 [3.878]	
	×100	103.5 [4.075]		123.5 [4.862]	
AWS16	×50	56.0 [2.205]	— Note	76.0 [2.992]	26.0 [1.024]
	×75	81.0 [3.189]		101.0 [3.976]	
	×100	106.0 [4.173]		126.0 [4.961]	
	×125	131.0 [5.157]		151.0 [5.944]	
AWS20	×50	63.5 [2.500]	13.5 [0.531]	83.5 [3.287]	33.5 [1.319]
	×75	88.5 [3.484]		108.5 [4.272]	
	×100	113.5 [4.469]		133.5 [5.256]	
	×125	138.5 [5.453]		158.5 [6.240]	
	×150	163.5 [6.437]		183.5 [7.224]	
AWS25	×50	64.0 [2.520]	14.0 [0.551]	84.0 [3.307]	34.0 [1.339]
	×75	89.0 [3.504]		109.0 [4.291]	
	×100	114.0 [4.488]		134.0 [5.276]	
	×125	139.0 [5.472]		159.0 [6.260]	
	×150	164.0 [6.457]		184.0 [7.244]	

Note: The sensor switch cannot be secured in place, because its mounting screw position is out of the mounting rail. Do not use in this position.

Discontinued