

QUICK FITTINGS SMART TYPE

● Renewal of our quick fittings, which have excellent durability and operability, with a new, smart form.

● One-touch connections are speedy.

Specifications

Item	Applicable tube size	$\phi 4$ [0.157], $\phi 6$ [0.236], $\phi 8$ [0.315], $\phi 10$ [0.394], $\phi 12$ [0.472], $\phi 16$ [0.630]
Media		Air
Maximum operating pressure		1 MPa [145 psi]
Operating vacuum pressure		-100 kPa [-29.5 inHg]
Operating temperature range		0~60°C [32~140°F]
Recommended tube ^{Note}		Urethane tube, nylon tube
Sales unit		1 pack (10 pcs.) [$\phi 16$ [0.630]] 1 pack (5 pcs.)

Remarks : Gasket or seal is already attached.

Note : Use Koganei tubes. Use tubes that have an outer diameter precision that is within a nominal diameter of ± 0.1 mm [0.004 in].

Inner Construction, Major Parts and Materials

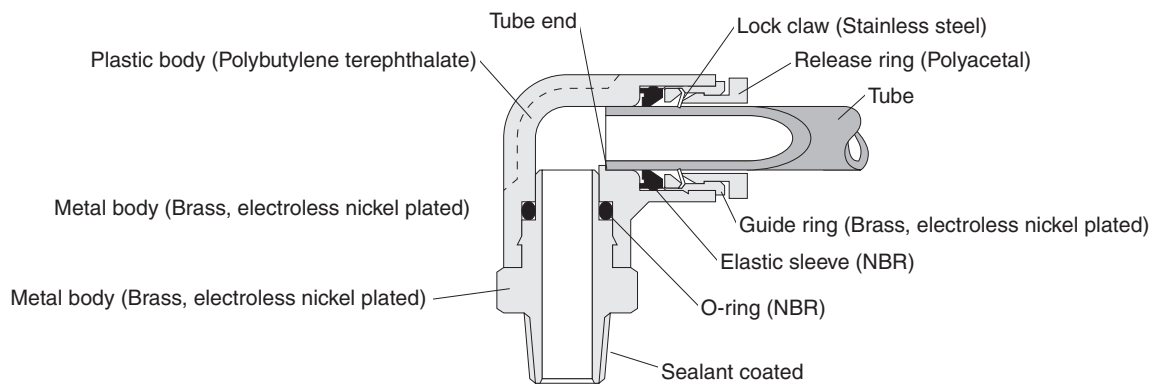

Straight

●ATS



(1 bag, 10 pcs.)

Tube size
0.157
0.236
0.315
0.394
0.472
0.630

Order codes

ATS

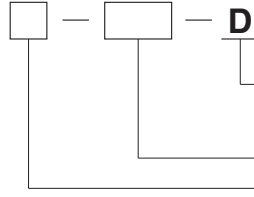

D ⇒ Non-lubricant specification only.
 □ ⇒ Select either blank (standard) or D (non-lubricant specification)
 Connecting thread
 Tube outer diameter

Dimensions in

Straight
ATS

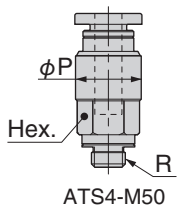
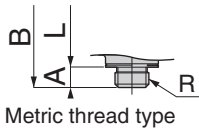
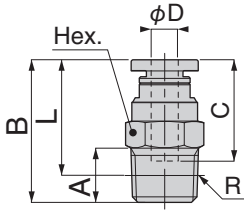

Model	Tube outer diameter ϕD	R	A	B	L	C	Width across flats Hex.	ϕP	Orifice diameter (ϕ in)	Mass oz
ATS4-M5-D	0.157	M5×0.8	0.110	0.780	0.669	0.587	0.394	-	0.094	0.198
ATS4-M50-□	0.157	M5×0.8	0.110	0.894	0.783	0.587	0.315	0.382	0.094	0.215
ATS4-M6-D	0.157	M6×1	0.150	0.819	0.669	0.587	0.394	-	0.118	0.212
ATS4-01-D	0.157	R1/8	0.315	0.827	0.669	0.587	0.394	-	0.118	0.261
ATS4-02-□	0.157	R1/4	0.433	0.886	0.650	0.587	0.551	-	0.118	0.564
ATS6-M5-D	0.236	M5×0.8	0.110	0.862	0.752	0.669	0.472	-	0.094	0.286
ATS6-M6-D	0.236	M6×1	0.150	0.902	0.752	0.669	0.472	-	0.118	0.300
ATS6-01-D	0.236	R1/8	0.315	0.878	0.720	0.669	0.472	-	0.197	0.289
ATS6-02-□	0.236	R1/4	0.433	0.933	0.693	0.669	0.551	-	0.197	0.529
ATS6-03-□	0.236	R3/8	0.472	0.965	0.713	0.669	0.669	-	0.197	0.988
ATS8-01-□	0.315	R1/8	0.315	1.098	0.941	0.717	0.551	-	0.236	0.494
ATS8-02-□	0.315	R1/4	0.433	1.047	0.811	0.717	0.551	-	0.276	0.494
ATS8-03-□	0.315	R3/8	0.472	1.004	0.756	0.717	0.669	-	0.276	0.882
ATS10-01-□	0.394	R1/8	0.315	1.193	1.035	0.815	0.669	-	0.236	0.741
ATS10-02-□	0.394	R1/4	0.433	1.173	0.937	0.815	0.669	-	0.335	0.670
ATS10-03-□	0.394	R3/8	0.472	1.154	0.906	0.815	0.669	-	0.354	0.847
ATS10-04-□	0.394	R1/2	0.591	1.197	0.874	0.815	0.827	-	0.354	1.623
ATS12-02-□	0.472	R1/4	0.433	1.413	1.177	0.917	0.827	-	0.335	1.305
ATS12-03-□	0.472	R3/8	0.472	1.256	1.008	0.917	0.827	-	0.433	1.058
ATS12-04-□	0.472	R1/2	0.591	1.335	1.012	0.917	0.827	-	0.433	1.552
ATS16-03-□	0.630	R3/8	0.472	1.547	1.299	0.976	0.945	-	0.433	1.905
ATS16-04-□	0.630	R1/2	0.591	1.626	1.303	0.976	0.945	-	0.512	2.222

* -D ⇒ Non-lubricant specification only. - □ ⇒ Select either blank (standard) or D (non-lubricant specification)

* The L dimension for the tapered thread types is a reference dimension when mated and tightened.

Straight

●ATS



(1 bag, 10 pcs.)

Tube size
4
6
8
10
12
16

Order codes

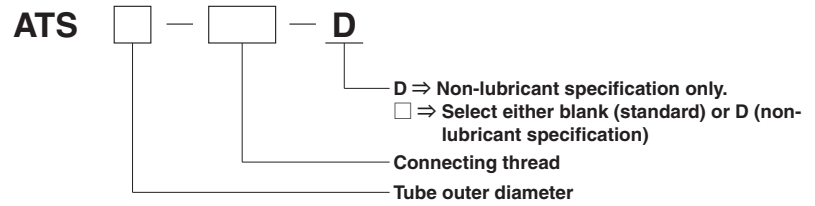

Dimensions mm

Straight
ATS

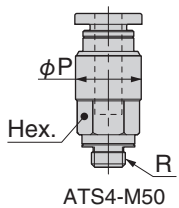
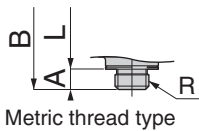
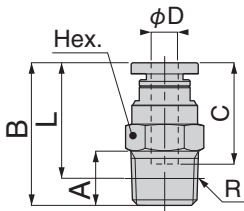

Model	Tube outer diameter φ D	R	A	B	L	C	Width across flats Hex.	φ P	Orifice diameter (φ mm)	Mass g
ATS4-M5-D	4	M5×0.8	2.8	19.8	17	14.9	10	—	2.4	5.6
ATS4-M50-□	4	M5×0.8	2.8	22.7	19.9	14.9	8	9.7	2.4	6.1
ATS4-M6-D	4	M6×1	3.8	20.8	17	14.9	10	—	3	6.0
ATS4-01-D	4	R1/8	8	21	17	14.9	10	—	3	7.4
ATS4-02-□	4	R1/4	11	22.5	16.5	14.9	14	—	3	16
ATS6-M5-D	6	M5×0.8	2.8	21.9	19.1	17	12	—	2.4	8.1
ATS6-M6-D	6	M6×1	3.8	22.9	19.1	17	12	—	3	8.5
ATS6-01-D	6	R1/8	8	22.3	18.3	17	12	—	5	8.2
ATS6-02-□	6	R1/4	11	23.7	17.6	17	14	—	5	15
ATS6-03-□	6	R3/8	12	24.5	18.1	17	17	—	5	28
ATS8-01-□	8	R1/8	8	27.9	23.9	18.2	14	—	6	14
ATS8-02-□	8	R1/4	11	26.6	20.6	18.2	14	—	7	14
ATS8-03-□	8	R3/8	12	25.5	19.2	18.2	17	—	7	25
ATS10-01-□	10	R1/8	8	30.3	26.3	20.7	17	—	6	21
ATS10-02-□	10	R1/4	11	29.8	23.8	20.7	17	—	8.5	19
ATS10-03-□	10	R3/8	12	29.3	23	20.7	17	—	9	24
ATS10-04-□	10	R1/2	15	30.4	22.2	20.7	21	—	9	46
ATS12-02-□	12	R1/4	11	35.9	29.9	23.3	21	—	8.5	37
ATS12-03-□	12	R3/8	12	31.9	25.6	23.3	21	—	11	30
ATS12-04-□	12	R1/2	15	33.9	25.7	23.3	21	—	11	44
ATS16-03-□	16	R3/8	12	39.3	33	24.8	24	—	11	54
ATS16-04-□	16	R1/2	15	41.3	33.1	24.8	24	—	13	63

* -D ⇒ Non-lubricant specification only. - □ ⇒ Select either blank (standard) or D (non-lubricant specification)

* The L dimension for the tapered thread types is a reference dimension when mated and tightened.

Safety precautions (Quick fittings standard type and mini type)

The safety precautions for the quick fittings standard type and mini type are shown on the right. Be sure to read the material in the front of the General Personal Catalog regarding safety precautions other than those on the right.

WARNING

- Use only the rotary type quick fitting when using fittings in situations in which the threaded side or the tube side swings or rotates. Swinging and rotating may result in damage to the fitting itself.

Handling instructions and precautions

● Mounting

Precautions for mounting fitting

- ① When mounting the fitting, use the appropriate tool to tighten the hex sockets or hex nuts on the fitting.
- ② Refer to the following table of recommended tightening torques when tightening the screws. If you use more than the recommended torque when tightening the screws, you may cause leaks by fracturing the threads or deforming the gaskets. If you use less than the recommended torque when tightening the threaded parts, it may result in looseness or leaks.
- ③ For products that cannot change their piping direction, adjust the screws to within the tightening torque of the fitting after tightening them.

Recommended tightening torque, sealant color, and gasket material

Thread type	Thread size	Tightening torque	Sealant color	Gasket material
Metric thread	M3 × 0.5 ^{Note}	0.7 N·m [6.196 in·lbf]	—	SUS304 NBR
	M5 × 0.8	1.0 to 1.5 N·m [8.851 to 13.277 in·lbf]		
	M6 × 1	1.8 to 2.3 N·m [15.932 to 20.357 in·lbf]		
	M6 × 0.75	0.8 to 1 N·m [7.081 to 8.851 in·lbf]		
Tapered threads for pipes	M8 × 0.75	1 to 2 N·m [8.851 to 17.702 in·lbf]	White	POM (Polyacetal)
	R1/8	7 to 9 N·m [61.957 to 79.659 in·lbf]		
	R1/4	12 to 14 N·m [106.212 to 123.914 in·lbf]		
	R3/8	22 to 24 N·m [194.722 to 212.424 in·lbf]		
	R1/2	28 to 30 N·m [247.828 to 265.530 in·lbf]		

Note: The tightening torque for the straight with hexagon socket (TSH2-M3M) is 0.3 N·m [2.655 in·lbf].

Precautions for disconnecting fittings

- ① When disconnecting fittings, use the appropriate tool to remove the hex sockets or hex nuts from the fitting.
- ② Remove the sealant from the threads on the other parts. If the sealant is stuck to the other parts, it may get into peripheral devices and cause a malfunction.

Tightening threaded parts

To tighten the screws, use a wrench or an impact wrench for the hex nuts, or use a hex wrench for the socket nuts (which require less space between fittings).

Be careful during the installation that you do not scratch the lock claw, which is in front of the hex socket on the Straight with hexagon socket (TSH), with the hex wrench. Damaging the edge of the lock claw may cause the tube to become detached.

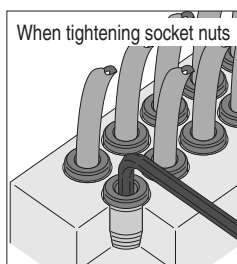
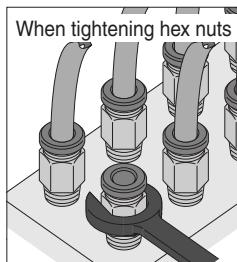

The sealant on the quick fittings can be reused multiple times, as is. However, the sealant may stick to the threaded parts of other devices. Be sure to clean the inside of the female threads on the devices.

● Attaching and detaching tubes

Precautions for attaching tubes

- ① Confirm that the cut surface of the tube is cut straight across, that the outer surface of the tube is not damaged, and that the tube has not become oval shaped.
- ② When connecting tubes, if you do not insert the tube all the way to the tube end, it may result in leaks.

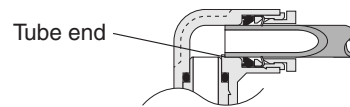

- ③ After installing the tube, pull on it to check that it does not come off.
- ④ Do not meaninglessly press on the release ring before attaching a tube. Doing so may cause the tube to become detached.

Precautions for removing tubes

- ① Before removing tubing, be sure to confirm that the pressure inside the tubing is zero.
- ② Uniformly press the release ring inwards as far as it goes and then pull out the tubing. If you do not fully press in on the release ring, the tube may not come out, or the tubing may become scratched causing debris to be left inside the fitting.

How to attach and detach tubes

① Attaching tubes

The quick fitting standard type is equipped with a lock claw that holds the tube in place when it has been pushed all the way to the end, and with an elastic sleeve for sealing the tube periphery.

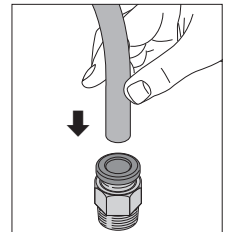

② Removing tubes

When removing a tube, pressing the release ring opens the lock claw and the tube can be pulled out. Be sure to turn off the air before removing tubes.

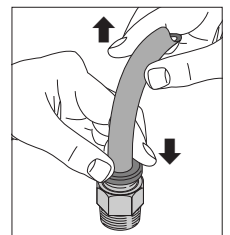

If removing pipes is difficult because the piping space is very constricted, consult your nearest Koganei sales office for specialized tools that are available.

Specialized tools for removing tubes

For $\phi 3$ [0.118], $\phi 4$ [0.157], and $\phi 6$ [0.236] tubes
Order codes: **UJ-1**



For $\phi 6$ [0.236], $\phi 8$ [0.315], $\phi 10$ [0.394], and $\phi 12$ [0.472] tubes
Order codes: **UJ-2**



Handling instructions and precautions

● Usable tubes

Use of both nylon tubing and urethane tubing are supported. Nylon tubing outside diameter precision should be within ± 0.1 mm [0.004 in] (nominal) for nylon tubing and within ± 0.15 mm [0.006 in] (nominal) for urethane tubing. Use tubing with ovality (difference between major axis and minor axis) within 0.2 mm [0.008 in] (use of Koganei tubing is recommended).

Use of tubing that is not a Koganei genuine product or a compatible (recommended) product may result in tube disconnection, air leakage, or other problems. Be sure to check on tubing before building a pneumatic system. Also, note that you cannot use the conductive urethane tube U2A-B produced by Koganei.



1. Use tubing with an exterior that is not damaged. If tubing becomes damaged after repeated use, cut off the damaged portion.
2. Do not allow tubing to become severely bent or twisted near the connection to a fitting. Such a condition creates the risk of air leakage. The table below shows minimum radius guidelines for nylon and urethane tubing.
3. Do not use extremely soft tubing, which causes a severe drop in pull-out strength.
4. Before removing any tubes, always turn off the air supply. Also, be sure to confirm that the air inside the pipes is safely vented before starting.

mm [in]

Tube size	Minimum bending radius	
	Nylon tube	Urethane tube
ϕ 1.8 [0.071]	—	4 [0.157]
ϕ 3 [0.118]	—	7 [0.276]
ϕ 4 [0.157]	20 [0.787]	10 [0.394]
ϕ 6 [0.236]	30 [1.181]	15 [0.591]
ϕ 8 [0.315]	50 [1.969]	20 [0.787]
ϕ 10 [0.394]	80 [3.150]	27 [1.063]
ϕ 12 [0.472]	150 [5.9]	35 [1.378]
ϕ 16 [0.630]	500 [19.7]	—