



ROTARY STAGE RWT Series

Air-operated index table

An air signal and ratchet mechanism ensure that the table rotates at a fixed angle and fixed direction. For operation principles, see p.1331.

Thin, lightweight, compact, and high torque

1.0N·m [0.74ft·lbf] (At operating air pressure 0.5MPa [73psi.]

10 times increase of allowable energy

(Compared to the previous model)



■ Sensor switch for operations check is optional.



■ Locating dowel pin holes placed on the top of the table and bottom of the body

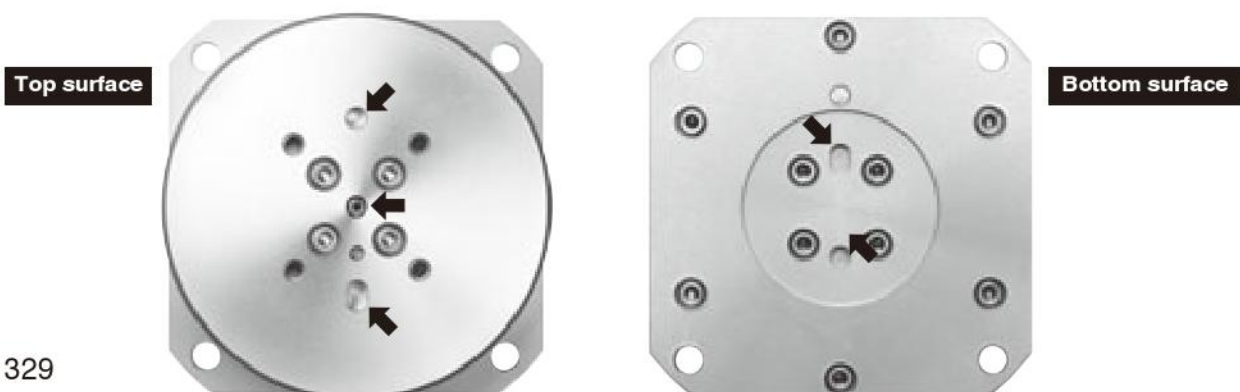

Two rotation directions: Rotation to the right (clockwise), Rotation to the left (counterclockwise)

Note: Will not rotate in reverse direction.

Three rotation angles: 45°, 60° and 90°

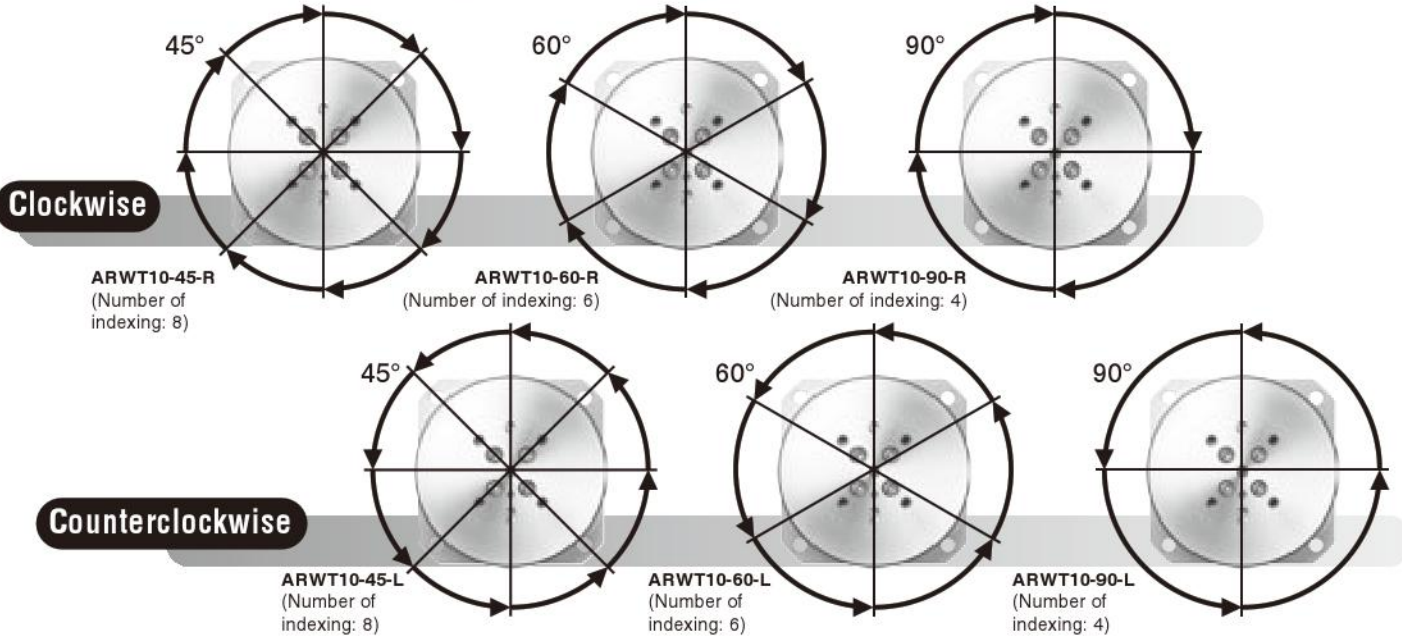

Application example

- Change the orientation of the circuit board and perform soldering.

(In combination with Creseed soldering unit)

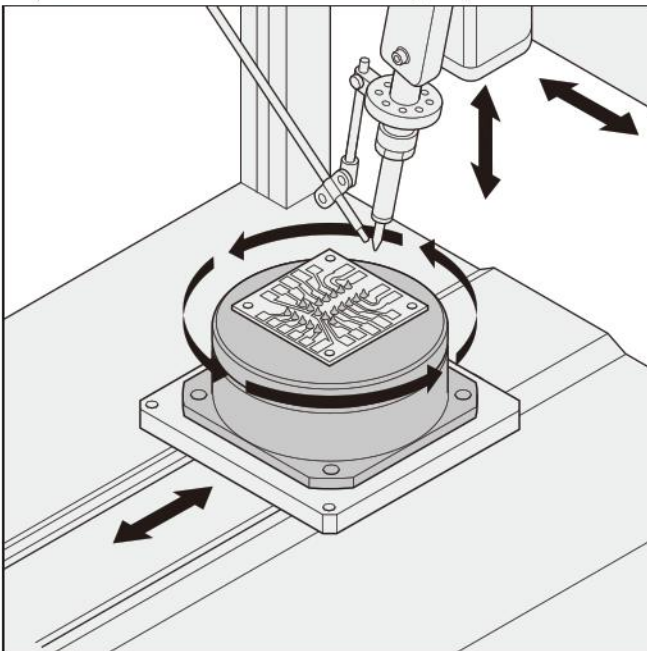

- Indexing table for automatic assembly

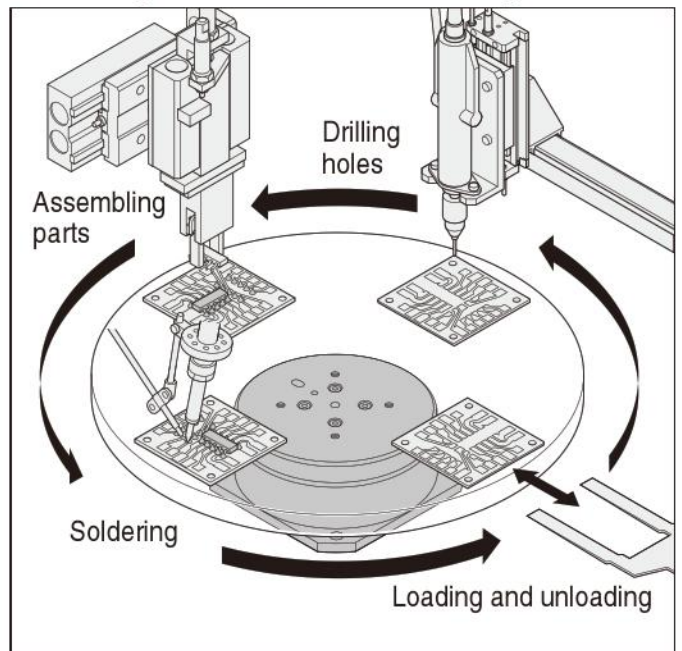

Operation Principles

Rotary Stage uses air signal and ratchet mechanism to ensure that the table rotates at a fixed angle and fixed direction.

Note: The diagrams show **ARWT10-90-R** (clockwise rotation). The **-L** type (counterclockwise rotation) is left-right symmetry.

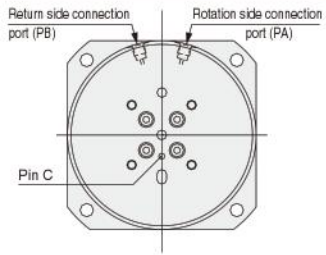
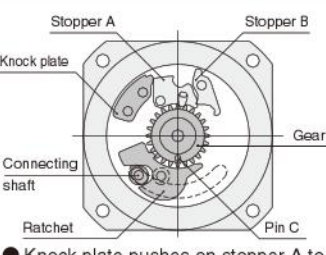
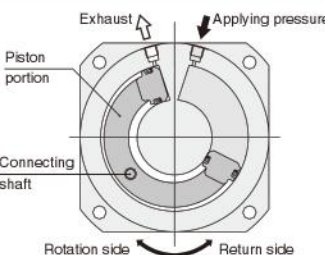
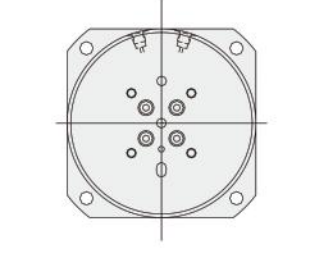
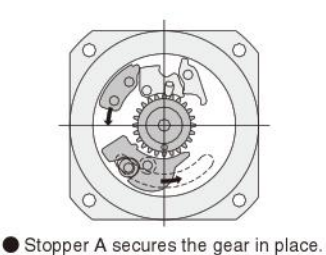
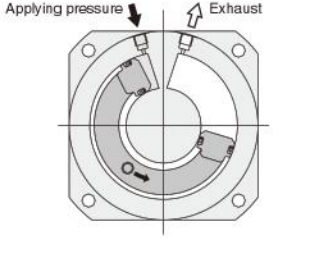
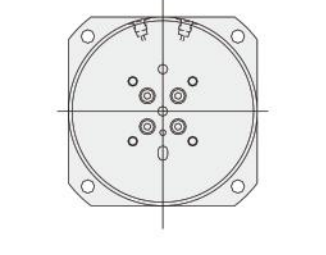
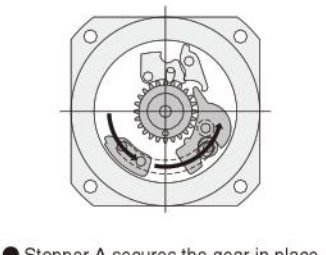
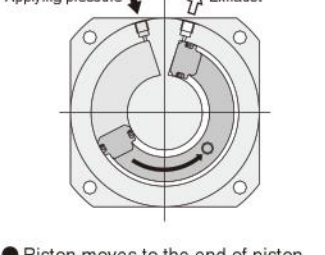
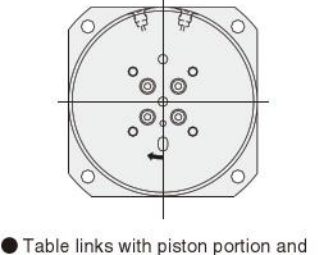
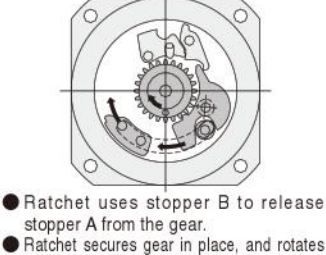
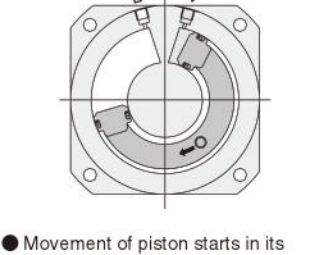
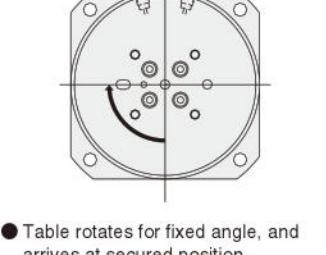
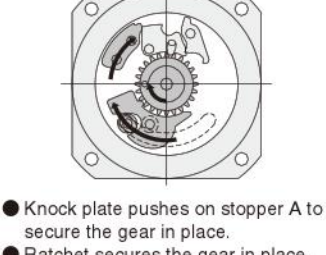
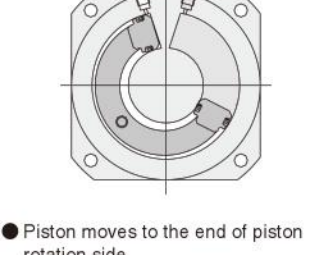
Process	Table operation	Ratchet mechanism operation	Piston portion operation
① Completion of table rotation	 <ul style="list-style-type: none"> ● Table in secured condition. 	 <ul style="list-style-type: none"> ● Knock plate pushes on stopper A to secure the gear in place. ● Ratchet secures the gear in place. 	 <ul style="list-style-type: none"> ● Piston moves to the end of piston rotation side.
② Start of piston return	 <ul style="list-style-type: none"> ● Table in secured condition. 	 <ul style="list-style-type: none"> ● Stopper A secures the gear in place. ● Ratchet releases the gear, and rotates along with the knock plate. 	 <ul style="list-style-type: none"> ● Movement of the piston starts in piston return side.
③ Completion of piston return	 <ul style="list-style-type: none"> ● Table in secured condition. 	 <ul style="list-style-type: none"> ● Stopper A secures the gear in place. ● Ratchet releases the gear. 	 <ul style="list-style-type: none"> ● Piston moves to the end of piston return side.
④ Start of table rotation	 <ul style="list-style-type: none"> ● Table links with piston portion and rotates. 	 <ul style="list-style-type: none"> ● Ratchet uses stopper B to release stopper A from the gear. ● Ratchet secures gear in place, and rotates along with the knock plate and gear. 	 <ul style="list-style-type: none"> ● Movement of piston starts in its rotation side.
⑤ Completion of table rotation	 <ul style="list-style-type: none"> ● Table rotates for fixed angle, and arrives at secured position. 	 <ul style="list-style-type: none"> ● Knock plate pushes on stopper A to secure the gear in place. ● Ratchet secures the gear in place. 	 <ul style="list-style-type: none"> ● Piston moves to the end of piston rotation side.

- The table is linked to the gear by pin C.
- The ratchet and knock plate are located on the same plate, and move in tandem.
- The ratchet is linked by a connecting shaft to the piston.
- The rotary stage RWT series goes through steps ①→②→③→④→⑤ above to complete 1 cycle.

Notes: 1. When operating the Rotary Stage RWT series, always start from the step "① Completion of table rotation."
 2. If the Rotary Stage RWT series stops while partway through rotation due to a drop in pressure, etc., always start from "③ Completion of piston return."
 3. When connecting the Rotary Stage RWT series to a valve, connect the normally open side to the rotation-side connection port.

Handling Instructions and Precautions



General precautions

Media

1. Use air for the media. For the use of any other media, consult us.
2. Air used for the actuator should be clean air that contains no deteriorated compressor oil, etc. Install an air filter (filtration of a minimum 40 μm) near the actuator or valve to remove collected liquid or dust. In addition, drain the air filter periodically.

Piping

1. Always thoroughly blow off (use compressed air) the tubing before connecting it to the actuator. Entering metal chips, sealing tape, rust, etc., generated during piping work could result in air leaks or other defective operation.
2. When screwing piping or fittings into the actuator, tighten to the appropriate tightening torque shown below.

Connecting thread	Tightening torque N·cm [in·lbf]
M5×0.8	157 [13.9]

Lubrication

The product can be used without lubrication, if lubrication is required, use Turbine Oil Class 1 (ISO VG32) or equivalent. Avoid using spindle oil or machine oil.

Atmosphere

If using in locations subject to dripping water, dripping oil, etc., use a cover to protect the unit. Also, avoid dew condensation.

Operation

When starting up operations of a device and the actuator by supplying compressed air rapidly, it could not control the speed due to the construction of the actuator, resulting in damage to the device and actuator. When shutting off compressed air, shut off with the table in a completely rotated state, and check that the stopper has activated. If for some reason the compressed air is shut off while the Rotary Stage is partway through a rotation, apply air pressure through the return side connection port (PB port) and continue applying back pressure in the operation to use. (See the operating principles on p.1331.)



Mounting

Mounting

1. Horizontal mounting (face up on the table surface) is the only acceptable mounting direction. Any other mounting directions will cause the inner parts to disengage, resulting in damage or defective operation.

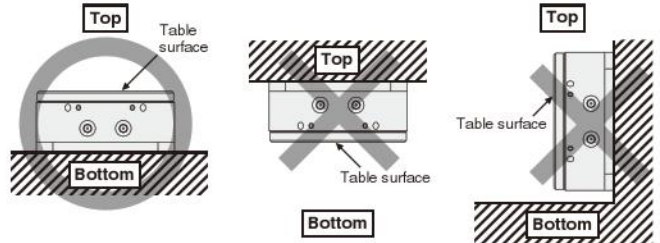

2. The mounting surface should always be flat. Twisting or bending during mounting may result in air leaks or improper operation.
3. Care should be taken that scratches or dents on the actuator's mounting surface may damage its flatness.
4. Take some locking measures when shocks or vibrations might loosen the bolts.

5. For workpiece mounting, female threads are available for installing the workpiece in place on the table. Always use bolts so that the screw length is less than the depth of the female thread. Use of longer bolts than the female thread will interfere with the inner parts, and prevent them from working properly.

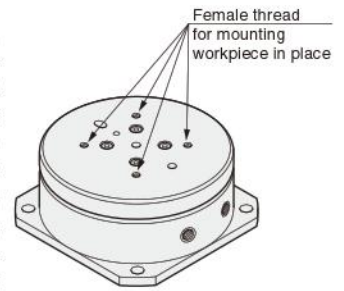

When mounting the workpiece, tighten the bolts within the range of the tightening torque.

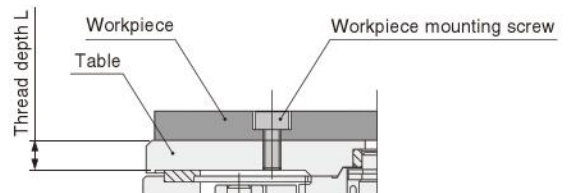

Model	Screw size	Thread depth L (mm [in.])	Maximum tightening torque (N·m) [ft·lbf]
ARWT10	M4×0.7	5 [0.197]	1.50 [1.11]

Caution: When using a bolt to mount the workpiece in place on the table, hold either the table or the workpiece during operation. Holding the body for tightening will apply excessive moment to the stopper or gear, etc., damaging them.

6. When mounting the Rotary Stage RWT series, tighten screws applying torque within the allowable range.

Mounting using through holes on the body

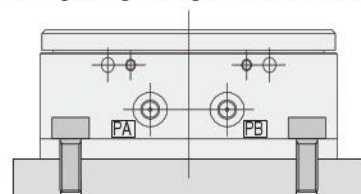

Model	Mounting	Screw size	Maximum tightening torque (N·m) [ft·lbf]
ARWT10	Through hole	M5×0.8	3.0 [2.2]

Handling Instructions and Precautions

● Allowable load

Item	Model	ARWT10
Allowable thrust load W_s (N [lbf.]) ^{Note1}		50 [11.2]
Allowable radial load W_R (N [lbf.]) ^{Note2}		0 [0]
Allowable bending moment M (N·m [ft·lbf])		1.5 [1.1]

Notes: 1. The thrust load has directionality. (See the diagram below.)
Do not apply it to the table surface in the up direction.
2. Cannot be used where a radial load is applied.

Thrust load

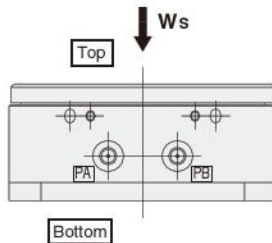

Radial load

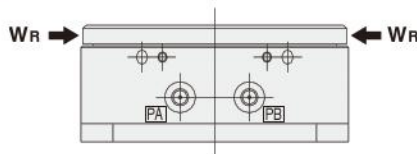

Bending moment

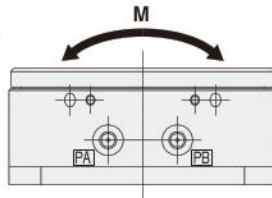

● Effective torque

N·m [ft·lbf]

Model	Air pressure MPa [psi.]									
	0.2 [29]	0.25 [36]	0.3 [44]	0.35 [51]	0.4 [58]	0.45 [65]	0.5 [73]	0.55 [80]	0.6 [87]	
ARWT10	0.4 [0.30]	0.5 [0.37]	0.6 [0.44]	0.7 [0.52]	0.8 [0.59]	0.9 [0.66]	1.0 [0.74]	1.1 [0.81]	1.2 [0.89]	

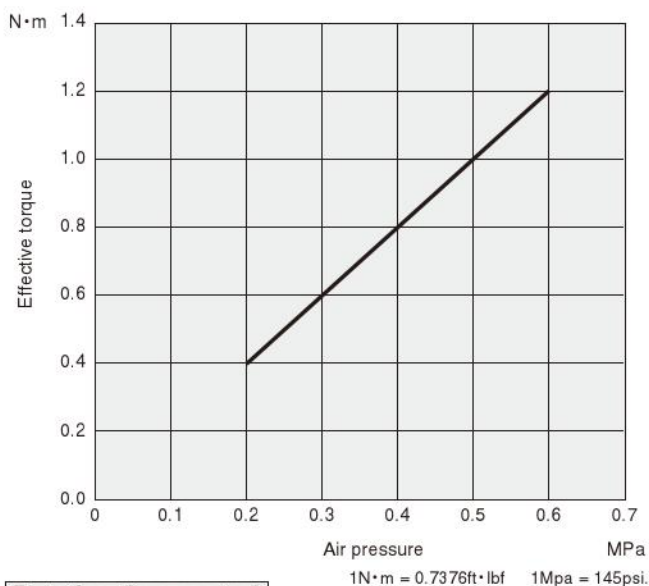

Rotation time control

For control of rotation time, a sequence control using sensor switches at both stroke ends for detection is recommended. If using timer control, caution should be exercised for the following points.

- For the rotation side, check that the rotation is completed all the way to the end point, and that the stopper positively activates.
- Because no visual check is possible for the return side, set the time to 0.2 second or more, without using a speed controller for adjustment.

Air Flow Rate and Air Consumption

● Finding the air flow rate (for selecting F.R.L., valves, etc.)

$$Q_1 = \left(6.4 \times \frac{60}{t} \times \frac{P+0.1013}{0.1013} + 200^* \right) \times 10^{-3}$$

$$Q_1' = \left(0.391 \times \frac{60}{t} \times \frac{P'+14.696}{14.696} + 12.20^* \right) \times \frac{1}{1728}$$

● Finding the air consumption

$$Q_2 = \left(V \times n \times \frac{P+0.1013}{0.1013} + 200^* \right) \times 10^{-3}$$

Q_1 : Required air flow rate for rotary stage ℓ /min (ANR)

Q_2 : Air consumption of rotary stage ℓ /min (ANR)

V : Cylinder capacity of rotary stage per cycle cm^3

t : Time required for 1 cycle of the rotary stage s

n : Number of operations per minute cycle/min

P : Pressure MPa

$$Q_2' = \left(V' \times n \times \frac{P'+14.696}{14.696} + 12.20^* \right) \times \frac{1}{1728}$$

Q_1' : Required air flow rate for rotary stage ft^3/min . (ANR)*

Q_2' : Air consumption of rotary stage ft^3/min . (ANR)*

V' : Cylinder capacity of rotary stage per cycle in^3

t : Time required for 1 cycle of the rotary stage sec.

n : Number of operations per minute cycle/min.

P' : Pressure psi.

*Refer to p.54 for an explanation of ANR.

※: The Rotary Stage RWT series may leak air when operated at less than 200 cm^3/min [12.20 in^3/min .] (ANR), because of the cylinder structure.

Cylinder capacity of rotary stage per cycle cm^3 [in^3]

Model	ARWT10-45	ARWT10-60	ARWT10-90
Cylinder capacity V [V']	9.6 [0.586]	10.6 [0.647]	12.8 [0.781]

Note: One cycle of the Rotary stage consists of movement that returns the device to the return position in preparation for traveling the internal piston by an air signal, and sending the table as far as a fixed angle. For table rotation and piston movement, see p.1331.

Selection

Caution: For the load and rotation time, follow the below "Model selection procedure" to select within the range of specified values. Moreover, about 80% of the allowable values is recommended to use in the application. By using these values, adverse effects on cylinders and guides can be a minimum.

● Model selection procedure

1. Check the application conditions

Check the following items ①~④

- ① Rotation angle (45°, 60° and 90°) and rotation direction (clockwise or counterclockwise rotation).
- ② Rotation time (s)
- ③ Applied pressure (MPa)
- ④ Workpiece shape and materials
- ⑤ Mounting direction (stance)

2. Check the rotation time

Check the rotation time in 1—② is within the rotation time adjustment range in the specification.

Angle	Rotation time (s)
45°	0.1~0.5
60°	0.13~0.67
90°	0.2~1.0

Note: The rotation time is the value for 1 complete rotation operating smoothly with applying no load.

3. Check torque

Find the torque T_A required for rotating the work.

$$T_A = I \dot{\omega} K$$

T_A : Torque (N·m)
 I : Mass moment of inertia (kg·m²)
 Use the formulas on p.1338~1341 to find.
 $\dot{\omega}$: Uniform angular acceleration (rad/s²)
 K : Marginal coefficient 5
 θ : Rotation angle (rad)
 45°→0.79rad
 60°→1.05rad
 90°→1.57rad
 t : Rotation time (s)

$$\dot{\omega} = \frac{2\theta}{t^2}$$

For the applied pressure checked in 1—③ above, use the effective torque table or graph on p.1333 to check that the required torque T_A is obtained.

4. Check kinetic energy

If kinetic energy exceeds the allowable energy, the actuator could be damaged. Always ensure that the energy lies within the allowed level. For the allowable kinetic energy, see Table 1.

Finding the kinetic energy.

$$E = \frac{1}{2} \times I \times \omega^2$$

E : Kinetic energy (J)
 I : Mass moment of inertia (kg·m²)
 Use the formulas on p.1338~1341 to find.
 ω : Angular velocity (rad/s)
 θ : Rotation angle (rad)
 45°→0.79rad
 60°→1.05rad
 90°→1.57rad
 t : Rotation time (s)
 E_a : Allowable energy
 ... See Table 1.

$$\omega = \frac{2\theta}{t}$$

$$E < E_a$$

Table 1. Allowable energy E_a

Model	Allowable energy (J)
ARWT10	0.050

● Model selection procedure

1. Check the application conditions

Check the following items ①~④

- ① Rotation angle (45°, 60° and 90°) and rotation direction (clockwise rotation or counterclockwise rotation).
- ② Rotation time [sec.]
- ③ Applied pressure [psi.]
- ④ Workpiece shape and materials
- ⑤ Mounting direction (stance)

2. Check the rotation time

Check the rotation time in 1—② is within the rotation time adjustment range in the specification.

Angle	Rotation time [sec.]
45°	0.1~0.5
60°	0.13~0.67
90°	0.2~1.0

Note: The rotation time is the value for 1 complete rotation operating smoothly with applying no load.

3. Check torque

Find the torque T'_A required for rotating the work.

$$T'_A = I' \dot{\omega} K$$

T'_A : Torque [ft·lbf]
 I' : Mass moment of inertia [lbf·ft·sec.²]
 Use the formulas on p.1338~1341 to find.
 $\dot{\omega}$: Uniform angular acceleration [rad/sec.²]
 K : Marginal coefficient 5
 θ : Rotation angle [rad]
 45°→0.79rad
 60°→1.05rad
 90°→1.57rad
 t : Rotation time [sec.]

$$\dot{\omega} = \frac{2\theta}{t^2}$$

For the applied pressure checked in 1—③ above, use the effective torque table or graph on p.1333 to check that the required torque T'_A is obtained.

4. Check kinetic energy

If kinetic energy exceeds the allowable energy, the actuator could be damaged. Always ensure that the energy lies within the allowed level. For the allowable kinetic energy, see Table 1.

Finding the kinetic energy.

$$E' = \frac{1}{2} \times I' \times \omega^2$$

E' : Kinetic energy [ft·lbf]
 I' : Mass moment of inertia [lbf·ft·sec.²]
 Use the formulas on p.1338~1341 to find.
 ω : Angular velocity [rad/sec.]
 θ : Rotation angle [rad]
 45°→0.79rad
 60°→1.05rad
 90°→1.57rad
 t : Rotation time [sec.]
 E'_a : Allowable energy
 ... See Table 1.

$$\omega = \frac{2\theta}{t}$$

$$E' < E'_a$$

Table 1. Allowable energy E'_a

Model	Allowable energy [ft·lbf]
ARWT10	0.037

Selection

5. Check load ratio

Check that the total sum of the load ratio does not exceed 1.
For the allowable load, see Table 2. (For the load direction, see the allowable load on p.1333.)

$$\frac{W_s}{W_{S\text{ MAX}}} + \frac{M}{M_{\text{ MAX}}} \leq 1$$

Table 2. Allowable load

Model	Thrust load $W_{S\text{ MAX}}$ (N)	Moment $M_{\text{ MAX}}$ (N·m)
ARWT10	50	1.5

6. Judgement whether the unit is usable or not

The unit is usable if it satisfies both 4. Kinetic energy and 5. Load ratio.

$$E < E_a$$

$$\text{Total sum of load ratio} \leq 1$$

5. Check load ratio

Check that the total sum of the load ratio does not exceed 1.
For the allowable load, see Table 2. (For the load direction, see the allowable load on p.1333.)

$$\frac{W'_s}{W'_{S\text{ MAX}}} + \frac{M'}{M'_{\text{ MAX}}} \leq 1$$

Table 2. Allowable load

Model	Thrust load $W'_{S\text{ MAX}}$ [lbf.]	Moment $M'_{\text{ MAX}}$ [ft·lbf]
ARWT10	11.2	1.1

6. Judgement whether the unit is usable or not

The unit is usable if it satisfies both 4. Kinetic energy and 5. Load ratio.

$$E' < E'_a$$

$$\text{Total sum of load ratio} \leq 1$$

● Calculation example

If solid circular cylinder workpiece is on the base.

(Unit: mm)

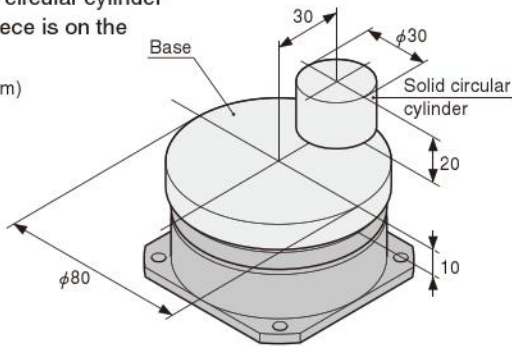

1. Check the application conditions

- ① Rotation angle: 90°
- ② Rotation time: 0.5 (s)
- ③ Applied pressure: 0.5 (MPa)
- ④ Workpiece shape...as shown in the above

Workpiece materials

...Base: Aluminum alloy A5056

(Specific gravity^{Note}= $2.64 \times 10^3 \text{ kg/m}^3$)

...Solid circular cylinder: Aluminum alloy A5056

(Specific gravity^{Note}= $2.64 \times 10^3 \text{ kg/m}^3$)

- ⑤ Mounting direction (stance): Horizontal

Note: Since the specific gravity can vary depending on the alloy, check the specific gravity of the metal being used, and then perform the calculation.

2. Check the rotation time

The rotation time is 0.5s/90°, which is within the range of 0.2~1.0s/90°, and satisfactory.

3. Check torque

Firstly calculate the mass moment of inertia.

Base

$$m_1 = \frac{\pi}{4} \times 0.08^2 \times 0.01 \times 2.64 \times 10^3 = 0.133 \text{ (kg)}$$

$$I_1 = \frac{0.133 \times 0.08^2}{8}$$

$$= 1.06 \times 10^{-4} \text{ (kg} \cdot \text{m}^2) \cdots \text{①}$$

Solid circular cylinder

$$m_2 = \frac{\pi}{4} \times 0.03^2 \times 0.02 \times 2.64 \times 10^3 = 0.037 \text{ (kg)}$$

$$I_2 = \frac{0.037 \times 0.03^2}{8} + 0.037 \times 0.03^2$$

$$= 0.37 \times 10^{-4} \text{ (kg} \cdot \text{m}^2) \cdots \text{②}$$

From ① and ②, the total mass moment of inertia I is

$$I = I_1 + I_2$$

$$= 1.06 \times 10^{-4} + 0.37 \times 10^{-4}$$

$$= 1.43 \times 10^{-4} \text{ (kg} \cdot \text{m}^2) \cdots \text{③}$$

From the given conditions, $\theta = 90^\circ$, $t = 0.5$ (s)

Therefore, uniform angular acceleration $\dot{\omega}$ is

$$\dot{\omega} = \frac{2 \times 1.57}{0.5^2} = 12.56 \text{ (rad/s}^2) \cdots \text{④}$$

From ③ and ④, the required torque T_A is

$$T_A = 1.43 \times 10^{-4} \times 12.56 \times 5$$

$$= 0.009 \text{ (N} \cdot \text{m)} \cdots \text{⑤}$$

The effective torque at 0.5MPa is 1.0 (N·m), and the torque is satisfactory.

● Calculation example

If solid circular cylinder workpiece is on the base.

(Unit: in.)

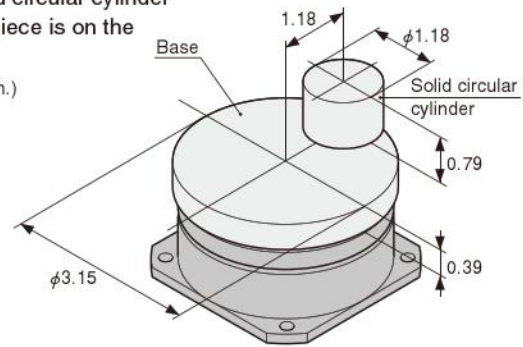

1. Check the application conditions

- ① Rotation angle: 90°
- ② Rotation time: 0.5 [sec.]
- ③ Applied pressure: 73 [psi.]
- ④ Workpiece shape...as shown in the above

Workpiece materials

...Base: Aluminum alloy A5056

[Specific gravity^{Note}=165lb/ft³]

...Solid circular cylinder: Aluminum alloy A5056

[Specific gravity^{Note}=165lb/ft³]

- ⑤ Mounting direction (stance): Horizontal

Note: Since the specific gravity can vary depending on the alloy, check the specific gravity of the metal being used, and then perform the calculation.

2. Check the rotation time

The rotation time is 0.5sec./90°, which is within the range of 0.2~1.0sec./90°, and satisfactory.

3. Check torque

Firstly calculate the mass moment of inertia.

Base

$$W_1 = \frac{\pi}{4} \times \left(\frac{3.15}{12}\right)^2 \times \left(\frac{0.39}{12}\right) \times 165 = 0.290 \text{ [lb.]}$$

$$I_1 = \frac{0.290 \times (3.15/12)^2}{8 \times 32.2}$$

$$= 7.76 \times 10^{-5} \text{ [lb} \cdot \text{ft} \cdot \text{sec}^2] \cdots \text{①}$$

Solid circular cylinder

$$W_2 = \frac{\pi}{4} \times \left(\frac{1.18}{12}\right)^2 \times \left(\frac{0.79}{12}\right) \times 165 = 0.082 \text{ [lb.]}$$

$$I_2 = \frac{0.082 \times (1.18/12)^2}{8 \times 32.2} + \frac{0.082 \times (1.18/12)^2}{32.2}$$

$$= 2.77 \times 10^{-5} \text{ [lb} \cdot \text{ft} \cdot \text{sec}^2] \cdots \text{②}$$

From ① and ②, the total mass moment of inertia I' is

$$I' = I_1 + I_2$$

$$= 7.76 \times 10^{-5} + 2.77 \times 10^{-5}$$

$$= 1.05 \times 10^{-4} \text{ [lb} \cdot \text{ft} \cdot \text{sec}^2] \cdots \text{③}$$

From the given conditions, $\theta = 90^\circ$, $t = 0.5$ [sec.]

Therefore, uniform angular acceleration $\dot{\omega}$ is

$$\dot{\omega} = \frac{2 \times 1.57}{0.5^2} = 12.56 \text{ [rad/sec}^2] \cdots \text{④}$$

From ③ and ④, the required torque T'_A is

$$T'_A = 1.05 \times 10^{-4} \times 12.56 \times 5$$

$$= 0.0066 \text{ [ft} \cdot \text{lb]} \cdots \text{⑤}$$

The effective torque at 73psi. is 0.74 [ft·lb], and the torque is satisfactory.

Selection

4. Check kinetic energy

From the given conditions, $\theta = 90^\circ$, $t = 0.5$ (s)
Therefore,

$$\omega = \frac{2 \times 1.57}{0.5} = 6.28 \text{ (rad/s)} \cdots \textcircled{1}$$

From $\textcircled{1}$, kinetic energy E is

$$E = \frac{1}{2} \times 1.43 \times 10^{-4} \times 6.28^2 = 0.003 \text{ (J)} \cdots \textcircled{2}$$

The allowable energy is 0.050 (J), and the kinetic energy is satisfactory.

5. Check load ratio

[Thrust load]

Total mass is

$$0.133 + 0.037 = 0.170 \text{ (kg)}$$

Therefore,

$$W_s = 0.170 \times 9.8 = 1.666 \text{ (N)} \cdots \textcircled{1}$$

[Moment]

Moment M_1 of the base is

$$M_1 = 0.133 \times 9.8 \times 0 = 0 \text{ (N}\cdot\text{m)} \cdots \textcircled{2}$$

Moment M_2 of the solid circular cylinder is

$$M_2 = 0.037 \times 9.8 \times 0.03 = 0.011 \text{ (N}\cdot\text{m)} \cdots \textcircled{3}$$

From $\textcircled{2}$ and $\textcircled{3}$, the total moment is

$$M = 0 + 0.011 = 0.011 \text{ (N}\cdot\text{m)} \cdots \textcircled{4}$$

From $\textcircled{1}$ and $\textcircled{4}$, find the load ratio.

$$\frac{W_s}{W_{s \text{ MAX}}} + \frac{M}{M_{\text{MAX}}} = \frac{1.666}{50} + \frac{0.011}{1.5} = 0.04 < 1.0$$

The load ratio is less than 1.0, and satisfactory.

6. Judgement whether the unit is usable or not

Since kinetic energy and load ratio are both satisfied, the application is allowable.

4. Check kinetic energy

From the given conditions, $\theta = 90^\circ$, $t = 0.5$ [sec.]
Therefore,

$$\omega = \frac{2 \times 1.57}{0.5} = 6.28 \text{ [rad/sec.]} \cdots \textcircled{1}$$

From $\textcircled{1}$, kinetic energy E' is

$$E' = \frac{1}{2} \times 1.02 \times 10^{-4} \times 6.28^2 = 0.002 \text{ [ft}\cdot\text{lbf]} \cdots \textcircled{2}$$

The allowable energy is 0.037 [ft·lbf], and the kinetic energy is satisfactory.

5. Check load ratio

[Thrust load]

Total weight is

$$0.290 + 0.082 = 0.372 \text{ [lbf.]}$$

Therefore,

$$W'_s = 0.372 \text{ [lbf.]} \cdots \textcircled{1}$$

[Moment]

Moment M'_1 of the base is

$$M'_1 = 0.290 \times 0 = 0 \text{ [ft}\cdot\text{lbf]} \cdots \textcircled{2}$$

Moment M'_2 of the solid circular cylinder is

$$M'_2 = 0.082 \times \left(\frac{1.18}{12} \right) = 0.008 \text{ [ft}\cdot\text{lbf]} \cdots \textcircled{3}$$

From $\textcircled{2}$ and $\textcircled{3}$, the total moment is

$$M' = 0 + 0.008 = 0.008 \text{ [ft}\cdot\text{lbf]} \cdots \textcircled{4}$$

From $\textcircled{1}$ and $\textcircled{4}$, find the load ratio.

$$\frac{W'_s}{W'_{s \text{ MAX}}} + \frac{M'}{M'_{\text{MAX}}} = \frac{0.373}{11.2} + \frac{0.008}{1.1} = 0.04 < 1.0$$

The load ratio is less than 1.0, and satisfactory.

6. Judgement whether the unit is usable or not

Since kinetic energy and load ratio are both satisfied, the application is allowable.

■ Diagram for calculating mass moment of inertia

[When the rotation axis passes through the workpiece]

● Disk

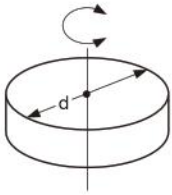

● Diameter	d (m)	■ Mass moment of inertia I (kg·m ²)	■ Rotating radius
● Mass	m (kg)	$I = \frac{md^2}{8}$	$\frac{d^2}{8}$
● Diameter	d [ft.]	■ Mass moment of inertia I' [lbf·ft·sec ²]	■ Rotating radius
● Weight	w [lbf.]	$I' = \frac{wd^2}{8 \times 32.2}$	$\frac{d^2}{8}$

Remark: For sliding use, see separate materials.

● Stepped disk

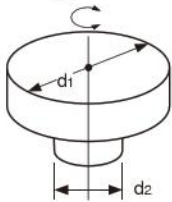

● Diameter	d ₁ (m)	■ Mass moment of inertia I (kg·m ²)	■ Rotating radius
● Mass	d ₂ (m)	$I = \frac{1}{8}(m_1d_1^2 + m_2d_2^2)$	$\frac{d_1^2 + d_2^2}{8}$
● Mass	m ₁ (kg)		
● Mass	m ₂ (kg)		
● Diameter	d ₁ [ft.]	■ Mass moment of inertia I' [lbf·ft·sec ²]	■ Rotating radius
● Weight	d ₂ [ft.]	$I' = \frac{1}{8 \times 32.2} \times (w_1d_1^2 + w_2d_2^2)$	$\frac{d_1^2 + d_2^2}{8}$
● Weight	w ₁ [lbf.]		
● Weight	w ₂ [lbf.]		

Remark: The d₂ portion can be negligible when it is much smaller than the d₁ portion.

● Bar (rotation center is at the edge)

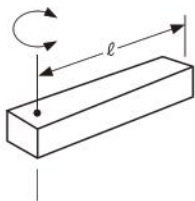

● Bar length	l (m)	■ Mass moment of inertia I (kg·m ²)	■ Rotating radius
● Mass	m (kg)	$I = \frac{m l^2}{3}$	$\frac{l^2}{3}$
● Bar length	l [ft.]	■ Mass moment of inertia I' [lbf·ft·sec ²]	■ Rotating radius
● Weight	w [lbf.]	$I' = \frac{w l^2}{3 \times 32.2}$	$\frac{l^2}{3}$

● Slender rod

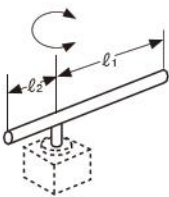

● Rod length	l ₁ (m)	■ Mass moment of inertia I (kg·m ²)	■ Rotating radius
● Mass	l ₂ (m)	$I = \frac{m_1l_1^2}{3} + \frac{m_2l_2^2}{3}$	$\frac{l_1^2 + l_2^2}{3}$
● Mass	m ₁ (kg)		
● Mass	m ₂ (kg)		
● Rod length	l ₁ [ft.]	■ Mass moment of inertia I' [lbf·ft·sec ²]	■ Rotating radius
● Weight	l ₂ [ft.]	$I' = \frac{w_1l_1^2}{3 \times 32.2} + \frac{w_2l_2^2}{3 \times 32.2}$	$\frac{l_1^2 + l_2^2}{3}$
● Weight	w ₁ [lbf.]		
● Weight	w ₂ [lbf.]		

● Bar (rotation center is through the center of gravity)

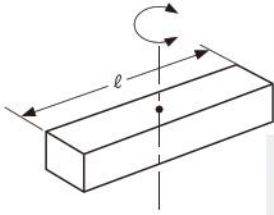

● Bar length	l (m)	■ Mass moment of inertia I ($\text{kg}\cdot\text{m}^2$)	■ Rotating radius
● Mass	m (kg)	$I = \frac{m l^2}{12}$	$\frac{l^2}{12}$
● Bar length	l [ft.]	■ Mass moment of inertia I' [$\text{lb}\cdot\text{ft}\cdot\text{sec}^2$]	■ Rotating radius
● Weight	w [lbf.]	$I' = \frac{w l^2}{12 \times 32.2}$	$\frac{l^2}{12}$

● Thin rectangular plate (rectangular solid)

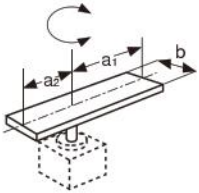

● Plate length	a_1 (m) a_2 (m)	■ Mass moment of inertia I ($\text{kg}\cdot\text{m}^2$)	■ Rotating radius
● Length of side	b (m)	$I = \frac{m_1}{12} (4a_1^2 + b^2) + \frac{m_2}{12} (4a_2^2 + b^2)$	$\frac{(4a_1^2 + b^2) + (4a_2^2 + b^2)}{12}$
● Mass	m_1 (kg) m_2 (kg)		
● Plate length	a_1 [ft.] a_2 [ft.]	■ Mass moment of inertia I' [$\text{lb}\cdot\text{ft}\cdot\text{sec}^2$]	■ Rotating radius
● Length of side	b [ft.]	$I' = \frac{w_1}{12 \times 32.2} (4a_1^2 + b^2) + \frac{w_2}{12 \times 32.2} (4a_2^2 + b^2)$	$\frac{(4a_1^2 + b^2) + (4a_2^2 + b^2)}{12}$
● Weight	w_1 [lbf.] w_2 [lbf.]		

● Rectangular parallelepiped

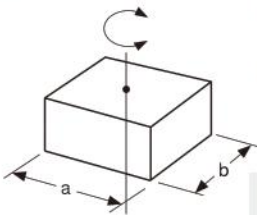

● Length of sides	a (m) b (m)	■ Mass moment of inertia I ($\text{kg}\cdot\text{m}^2$)	■ Rotating radius
● Mass	m (kg)	$I = \frac{m}{12} (a^2 + b^2)$	$\frac{a^2 + b^2}{12}$
● Length of sides	a [ft.] b [ft.]	■ Mass moment inertia I' [$\text{lb}\cdot\text{ft}\cdot\text{sec}^2$]	■ Rotating radius
● Weight	w [lbf.]	$I' = \frac{w}{12 \times 32.2} (a^2 + b^2)$	$\frac{a^2 + b^2}{12}$

Remark: For sliding use, see separate materials.

● Concentrated load

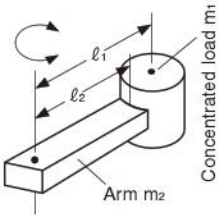

- Shape of concentrated load
- Distance to center of gravity of concentrated load l_1 (m)
- Length of arm l_2 (m)
- Mass of concentrated load m_1 (kg)
- Mass of arm m_2 (kg)

■ Mass moment of inertia I ($\text{kg}\cdot\text{m}^2$)

$$I = m_1 k^2 + m_1 l_1^2 + \frac{m_2 l_2^2}{3}$$

Rotating radius: k^2 is calculated according to shape of the concentrated load.

Remark: When m_2 is much smaller than m_1 , calculate as $m_2 = 0$.

- Shape of concentrated load
- Distance to center of gravity of concentrated load l_1 [ft.]
- Length of arm l_2 [ft.]
- Weight of concentrated load w_1 [lbf.]
- Weight of arm w_2 [lbf.]

■ Mass moment of inertia I' [$\text{lbf}\cdot\text{ft}\cdot\text{sec}^2$]

$$I' = \frac{w_1 k^2}{32.2} + \frac{w_1 l_1^2}{32.2} + \frac{w_2}{32.2} \times \frac{l_2^2}{3}$$

Rotating radius: k^2 is calculated according to shape of the concentrated load.

Remark: When w_2 is much smaller than w_1 , calculate as $w_2 = 0$.

● Gear Equation for calculating the load J_L with respect to Rotary Stage axis when transmitted by gears

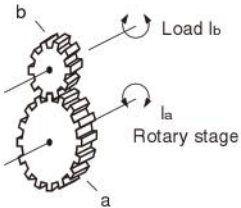

- Gear Rotary Stage side a
- Load side b
- Inertia moment of load I_a $\text{N}\cdot\text{m}$

■ Mass moment of inertia I ($\text{kg}\cdot\text{m}^2$)

Mass moment of inertia of load with respect to Rotary Stage axis

$$I_a = \left(\frac{a}{b}\right)^2 I_b$$

- Gear Rotary Stage side a
- Load side b
- Inertia moment of load I_a $\text{ft}\cdot\text{lbf}$

■ Mass moment of inertia I' [$\text{lbf}\cdot\text{ft}\cdot\text{sec}^2$]

Mass moment of inertia of load with respect to Rotary Stage axis

$$I_a = \left(\frac{a}{b}\right)^2 I_b$$

Remark: If the shapes of the gears are too large, the mass moment of inertia of the gears must be also taken into consideration.

[When the rotation axis is offset from the workpiece]

● Rectangular parallelepiped

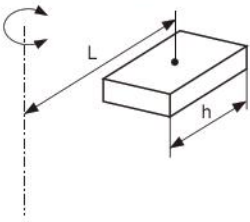

- Length of side h (m)
- Distance from rotation axis to the center of load L (m)
- Mass m (kg)

■ Mass moment of inertia I (kg·m²)

$$I = \frac{mh^2}{12} + mL^2$$

- Length of side h [ft.]
- Distance from rotation axis to the center of load L [ft.]
- Weight w [lbf.]

■ Mass moment of inertia I' [lbf·ft·sec²]

$$I' = \frac{wh^2}{32.2 \times 12} + \frac{wL^2}{32.2}$$

Remark: Same for cube.

● Hollow rectangular parallelepiped

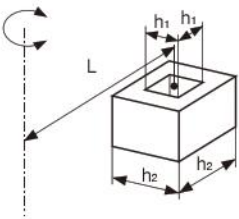

- Length of side h₁ (m)
- h₂ (m)
- Distance from rotation axis to the center of load L (m)
- Mass m (kg)

■ Mass moment of inertia I (kg·m²)

$$I = \frac{m}{12} (h_2^2 + h_1^2) + mL^2$$

- Length of side h₁ [ft.]
- h₂ [ft.]
- Distance from rotation axis to the center of load L [ft.]
- Weight w [lbf.]

■ Mass moment of inertia I' [lbf·ft·sec²]

$$I' = \frac{w(h_2^2 + h_1^2)}{32.2 \times 12} + \frac{wL^2}{32.2}$$

Remark: Cross-section is square only.

● Circular cylinder

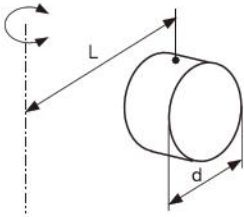

- Diameter d (m)
- Distance from rotation axis to the center of load L (m)
- Mass m (kg)

■ Mass moment of inertia I (kg·m²)

$$I = \frac{md^2}{16} + mL^2$$

- Diameter d [ft.]
- Distance from rotation axis to the center of load L [ft.]
- Weight w [lbf.]

■ Mass moment of inertia I' [lbf·ft·sec²]

$$I' = \frac{wd^2}{32.2 \times 16} + \frac{wL^2}{32.2}$$

● Hollow circular cylinder

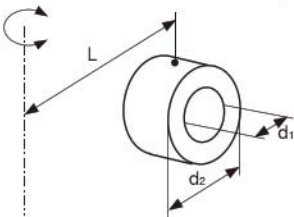

- Diameter d₁ (m)
- d₂ (m)
- Distance from rotation axis to the center of load L (m)
- Mass m (kg)

■ Mass moment of inertia I (kg·m²)

$$I = \frac{m}{16} (d_2^2 + d_1^2) + mL^2$$

- Diameter d₁ [ft.]
- d₂ [ft.]
- Distance from rotation axis to the center of load L [ft.]
- Weight w [lbf.]

■ Mass moment of inertia I' [lbf·ft·sec²]

$$I' = \frac{w(d_2^2 + d_1^2)}{32.2 \times 16} + \frac{wL^2}{32.2}$$

ROTARY STAGE

RWT Series



Symbol

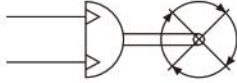

Specifications

Item	Model	ARWT10-45-R	ARWT10-45-L	ARWT10-60-R	ARWT10-60-L	ARWT10-90-R	ARWT10-90-L
Operation type		Double acting piston type (Gear and ratchet mechanism)					
Effective torque ^{Note 1}	N · m [ft · lbf]	1.0 [0.74]					
Media		Air					
Operating pressure range	MPa [psi.]	0.2~0.6 [29~87]					
Proof pressure	MPa [psi.]	0.9 [131]					
Operating temperature range	°C [°F]	0~60 [32~140] (Dew condensation prohibited)					
Rotation direction		Clockwise	Counterclockwise	Clockwise	Counterclockwise	Clockwise	Counterclockwise
Rotation angle		45°±0.2°		60°±0.2°		90°±0.2°	
Rotation time adjustment range ^{Note 2}	s/90°	0.2~1.0					
Allowable energy	J [ft · lbf]	0.050 [0.037]					
Allowable thrust load	N [lbf.]	50 [11.2]					
Allowable moment	N · m [ft · lbf]	1.5 [1.1]					
Lubrication		Not required (If lubrication is required, use Turbine Oil Class 1 [ISO VG32] or equivalent.)					
Port size		M5×0.8					

Notes: 1. Effective torque is the value obtained when the pressure is 0.5MPa [73psi.].

2. The rotation time adjustment range is the value for one complete rotation operating smoothly with applying no load.

Mass

Model	ARWT10-45-R	ARWT10-45-L	ARWT10-60-R	ARWT10-60-L	ARWT10-90-R	ARWT10-90-L
Body	473 [16.68]		472 [16.65]		470 [16.58]	
Sensor switch Assy ^{Note}	30 [1.06]					

Note: Mass for 1 sensor switch Assy set (including 3m [118in.] cable)

Order Codes

ARWT 10 - [] - [] - []

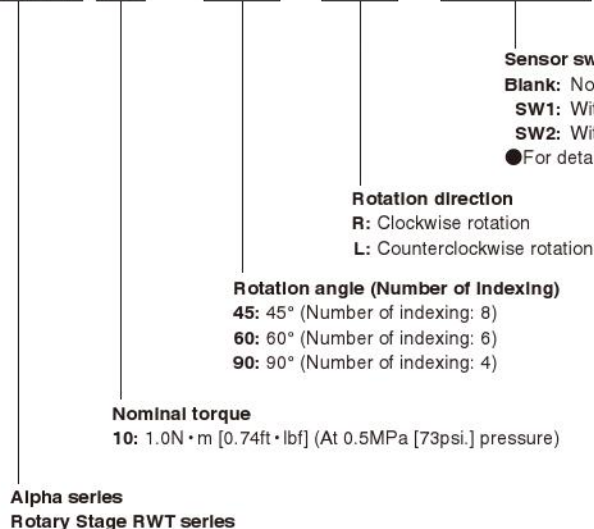

Inner Construction

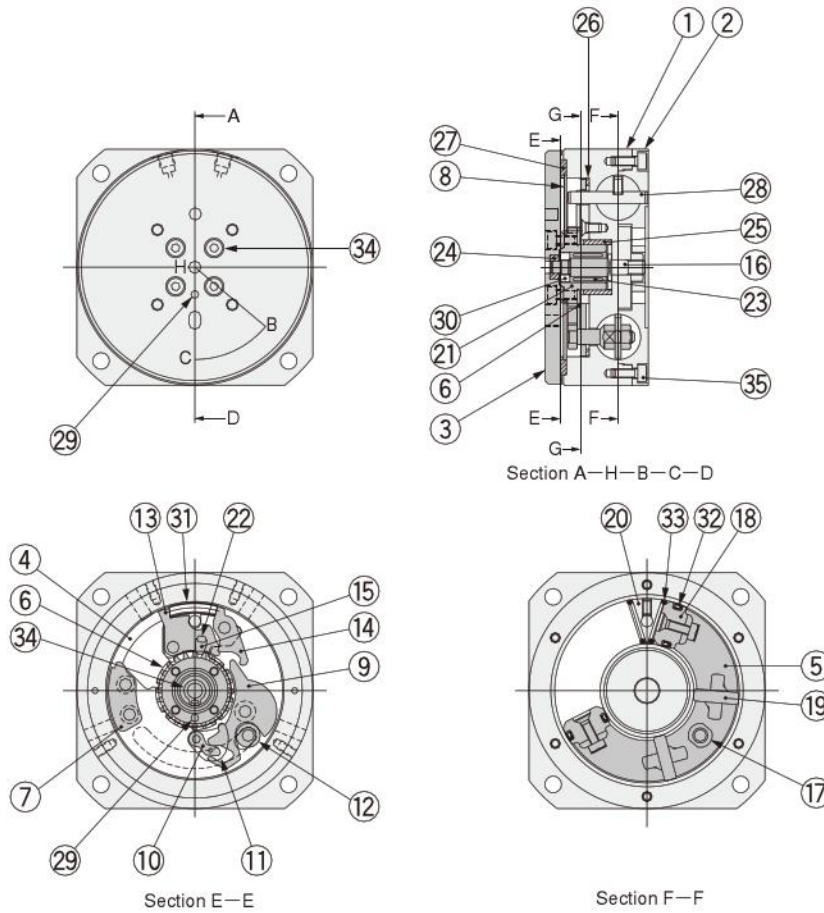

Note: The diagrams show the -R type (clockwise rotation). The -L type (counterclockwise rotation) is left-right symmetry.

Major Parts and Materials

No.	Parts	Materials
①	Body A	Aluminum alloy (anodized)
②	Body B	Aluminum alloy (anodized)
③	Table	Aluminum alloy (anodized)
④	Base A	Stainless steel
⑤	Swing plate	Stainless steel
⑥	Index plate	Steel
⑦	Knock plate	Steel
⑧	Cover	Stainless steel
⑨	Ratchet	Steel
⑩	Cam	Steel
⑪	Pawl	Steel
⑫	Roller	Steel
⑬	Stopper A	Steel
⑭	Stopper B	Steel
⑮	Stopper C	Steel
⑯	Main shaft	Steel
⑰	Connecting shaft	Steel
⑱	Piston	Plastic

No.	Parts	Materials
⑲	Retainer	Plastic
⑳	Separator	Plastic
㉑	Gear	Steel
㉒	Bumper	Synthetic rubber (Urethane)
㉓	Clutch	—
㉔	Bushing A	Brass
㉕	Bushing B	Brass
㉖	Bushing D	Brass
㉗	Bushing E	Brass
㉘	Connecting pin	Stainless steel
㉙	Pin C	Stainless steel
㉚	Nut	Stainless steel
㉛	Spring	Stainless steel
㉜	Piston seal	Synthetic rubber (NBR)
㉝	O-ring	Synthetic rubber (NBR)
㉞	Hexagon socket head bolt	Stainless steel
㉟	Hexagon socket head bolt	Stainless steel

Dimensions (mm)

ARWT10-□-R-Sensor switch Assy

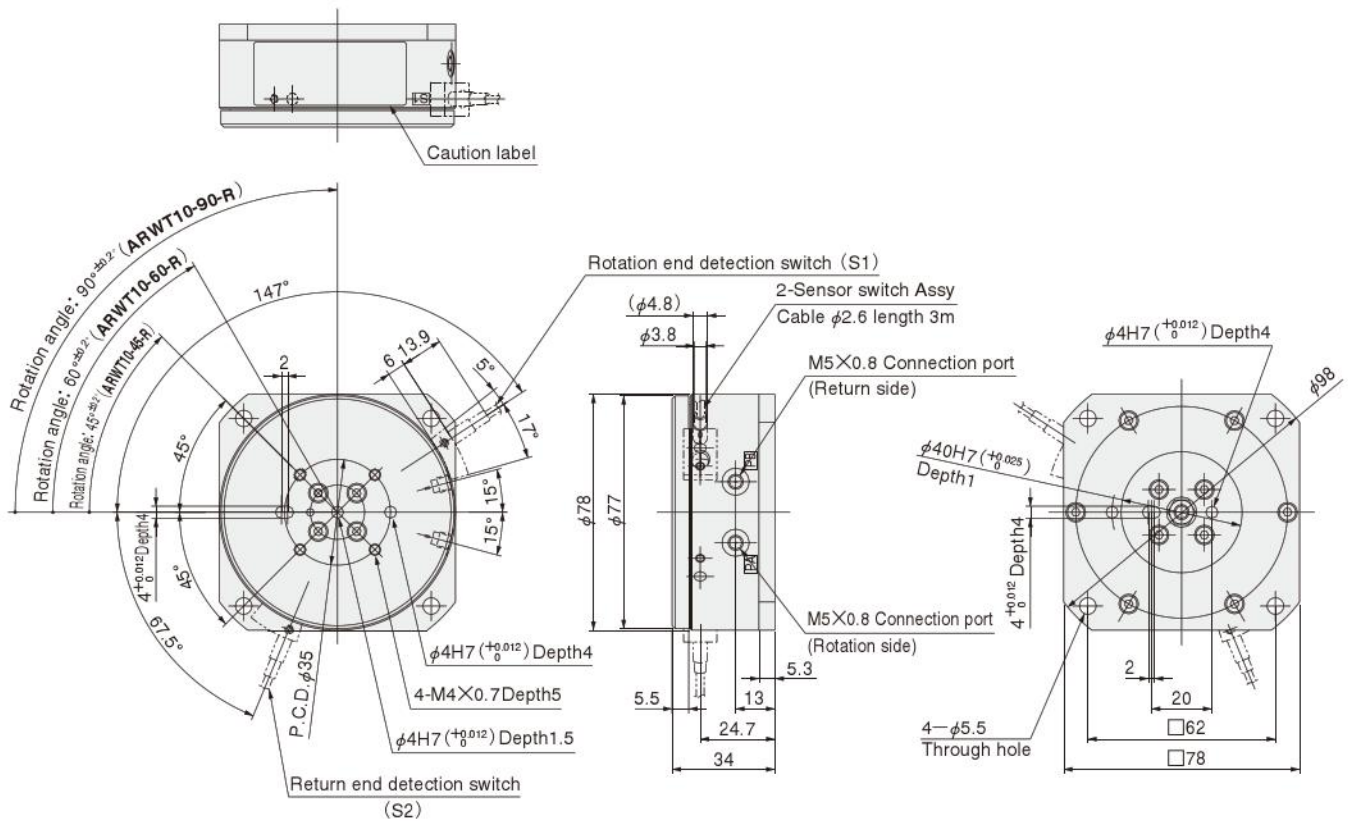

ARWT10-□-L-Sensor switch Assy

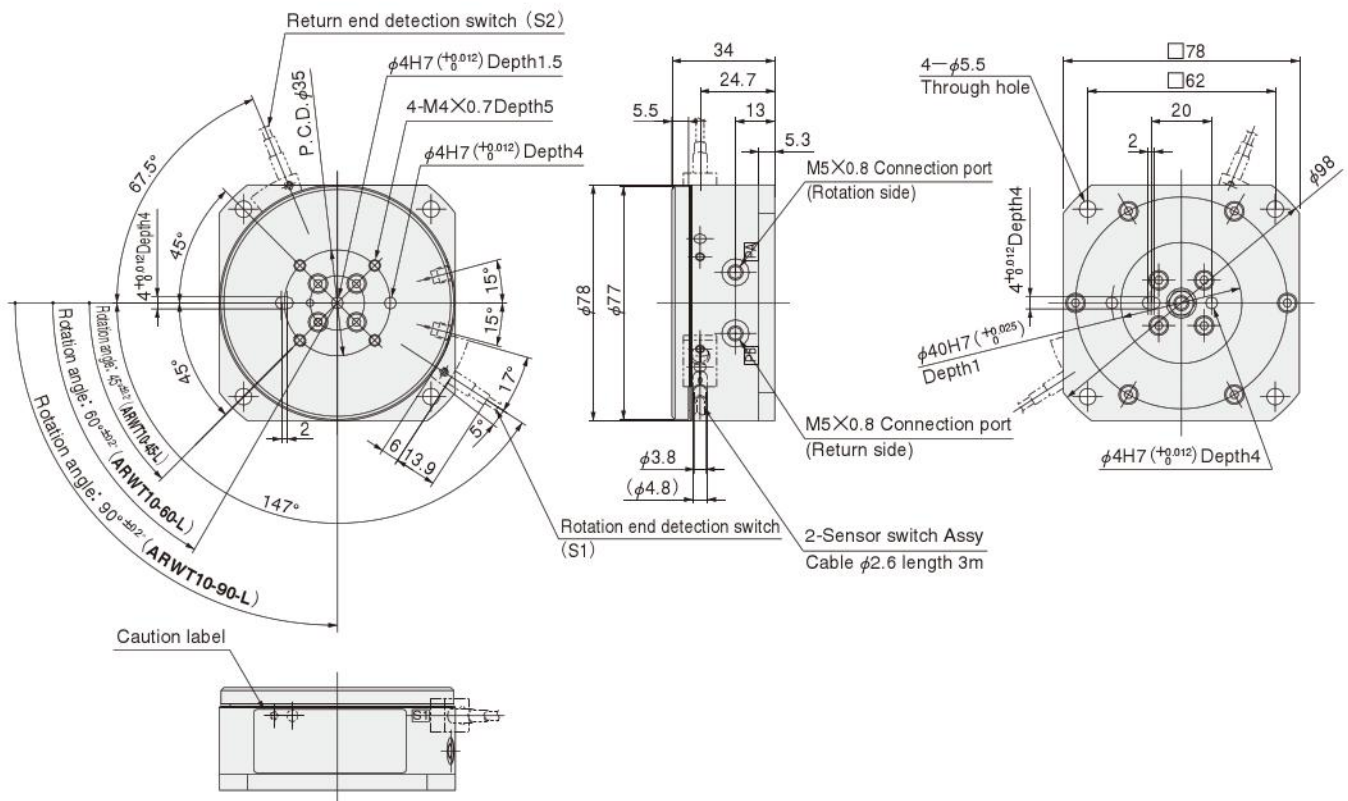

SENSOR SWITCH

Specifications

Item	Model	SW-ARWT
Maximum detection distance ^{Note 1}		0.8mm [0.031in.]±15%
Stable detection range ^{Note 2}		0~0.6mm [0~0.024in.]
Standard detected object		Steel 5×5×t1mm [0.20×0.20×0.04 (thickness) in.]
Response differential (Hysteresis)		15% or less of operating distance
Repeatability		20 μm or less
Voltage		12~24V DC±10% Ripple P-P 10% or less
Consumption current		15mA or less
Output		NPN transistor open collector ●Maximum inrush current: 50mA ●Applied voltage: 30V DC or less ●Residual voltage: 0.4V or less (at 50mA inrush current)
Output (operation)		Switches ON upon approach
Maximum response frequency		1kHz
Indicator lamp		Red LED (Lights up when output is ON)
Environmental resistance	Protective structure	IP67 (IEC), Watertight type (JIS) ^{Note 3}
	Ambient temperature	-25~70°C [-13~158°F], in storage: -25~80°C [-13~176°F]
	Ambient humidity	35~95%RH, in storage: 35~95%RH
	Dielectric strength	AC500V 1 minute (Between every charging portion and case)
	Insulation resistance	5MΩ or more at DC250V megger (Between every charging portion and case)
	Vibration resistance	10~55Hz Total amplitude 1.5mm [0.059in.] 2 hours for each X, Y, and Z direction (De-energized)
	Shock resistance	200m/s ² (approx. 20G) 10 times for each X, Y, and Z direction (De-energized)
Variation of detection distance	Temperature characteristics	Within ±20% of detection distance at 20°C [68°F], in ambient temperature -25~70°C [-13~158°F].
	Voltage characteristics	Within ±2% when operating voltage variation is ±10%.
Materials		Case: stainless steel (SUS304), Plastic portion: TPX
Cable		0.08mm ² [1.24×10 ⁻⁴ in ²] 3-lead Oil-resistant, heat-resistant, cold-resistant, with cabtyre cable 3m [118in.]
Mass		Approximately 30g [1.06oz.]

Notes: 1. Maximum detection distance refers to the maximum detection distance for standard detected object.

2. Stable detection range refers to the distance range at which stable detection of a standard detected object is obtained, with consideration for ambient temperature and variations in supply voltage.

3. While protective structure is prescribed the sensor switch including the cable, the end of the cable is not treated to be waterproof, and therefore cannot be a target for protective structure.

For this reason, avoid applications where there is a possibility that water could intrude through the end of the cable.

⚠ Caution

Use in combinations with devices of the Rotary Stage RWT series only.

The sensor switch Assy (SW-ARWT) is designed to be used in combination with the Rotary Stage RWT series. Use in combination with other actuators could cause abnormal operation.

Do not allow water to intrude here.

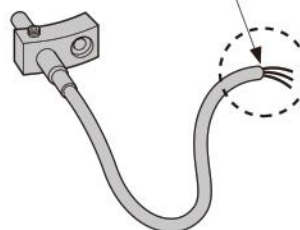

Order Code

SW - ARWT

Series

ARWT: Alpha series Rotary Stage RWT series

Sensor switch Assy (with a holder and a mounting screw)

Dimensions of Sensor Switch (mm)

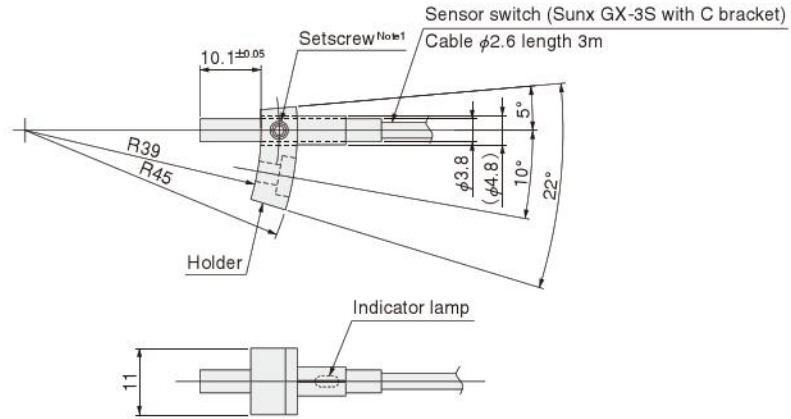

- Notes: 1. Do not loosen the setscrew. Changing the protruding length from the sensor switch holder could result in damage or defective operations.
 2. When re-tightening the setscrew, check the protruding length from the holder, and fasten at a tightening torque of $0.29\text{N} \cdot \text{m}$ [$2.6\text{in} \cdot \text{lbf}$] $\pm 10\%$ at a direction perpendicular to the indicator lamp.
 3. One mounting pan screw (M3 \times 0.5 length 8) is included in the sensor switch.

Internal Circuit Diagrams

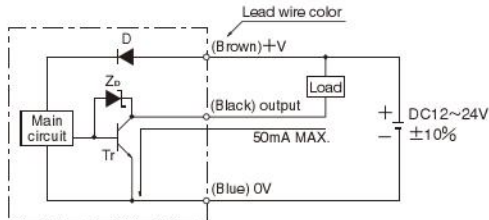

Code...D: Reverse current protection diode
 ZD: Zener diode for surge voltage protection
 Tr: NPN output transistor

Mounting Sensor Switch

- Tighten the mounting pan screw with a tightening torque of $0.63\text{N} \cdot \text{m}$ [$5.6\text{in} \cdot \text{lbf}$].

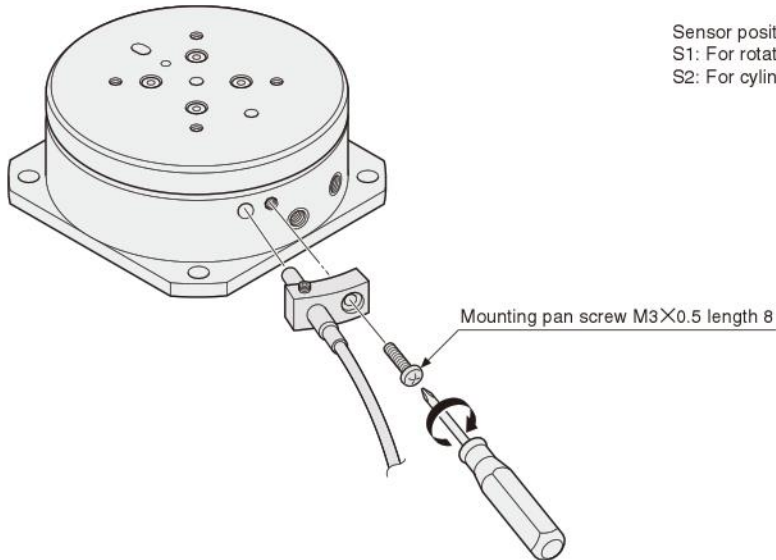

Sensor position identification label
 S1: For rotation end check
 S2: For cylinder return check