

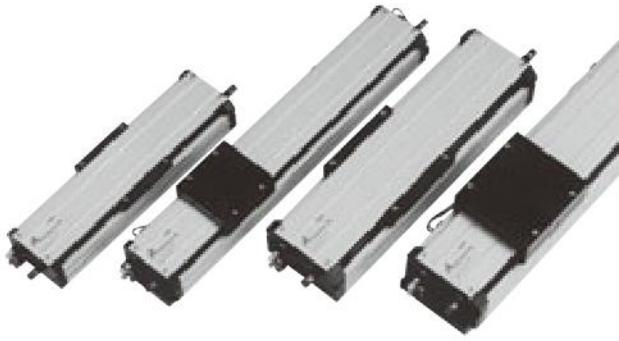

CAD drawing data catalog
is available.



KOGANEI

ACTUATORS GENERAL CATALOG



RT SLIDE TABLES B TYPE CONTENTS

Features	1007
Specifications	1009
Order Codes	1010
Allowable Bending Moment and Displacement	1011
Dimensions	1012
Handling Instructions and Precautions	1014

RT SLIDE TABLES (B TYPE)

Discontinued



Caution

Before use, be sure to read the "Safety Precautions" on p. 57.

More precision



We have added advanced positioning precision and high rigidity to the pneumatic actuator.

The Koganel Alpha Series further enhances the drive module concept, supporting superior applications and labor savings in FA line design and manufacturing with higher performance.

RT SLIDE TABLES (B TYPE)

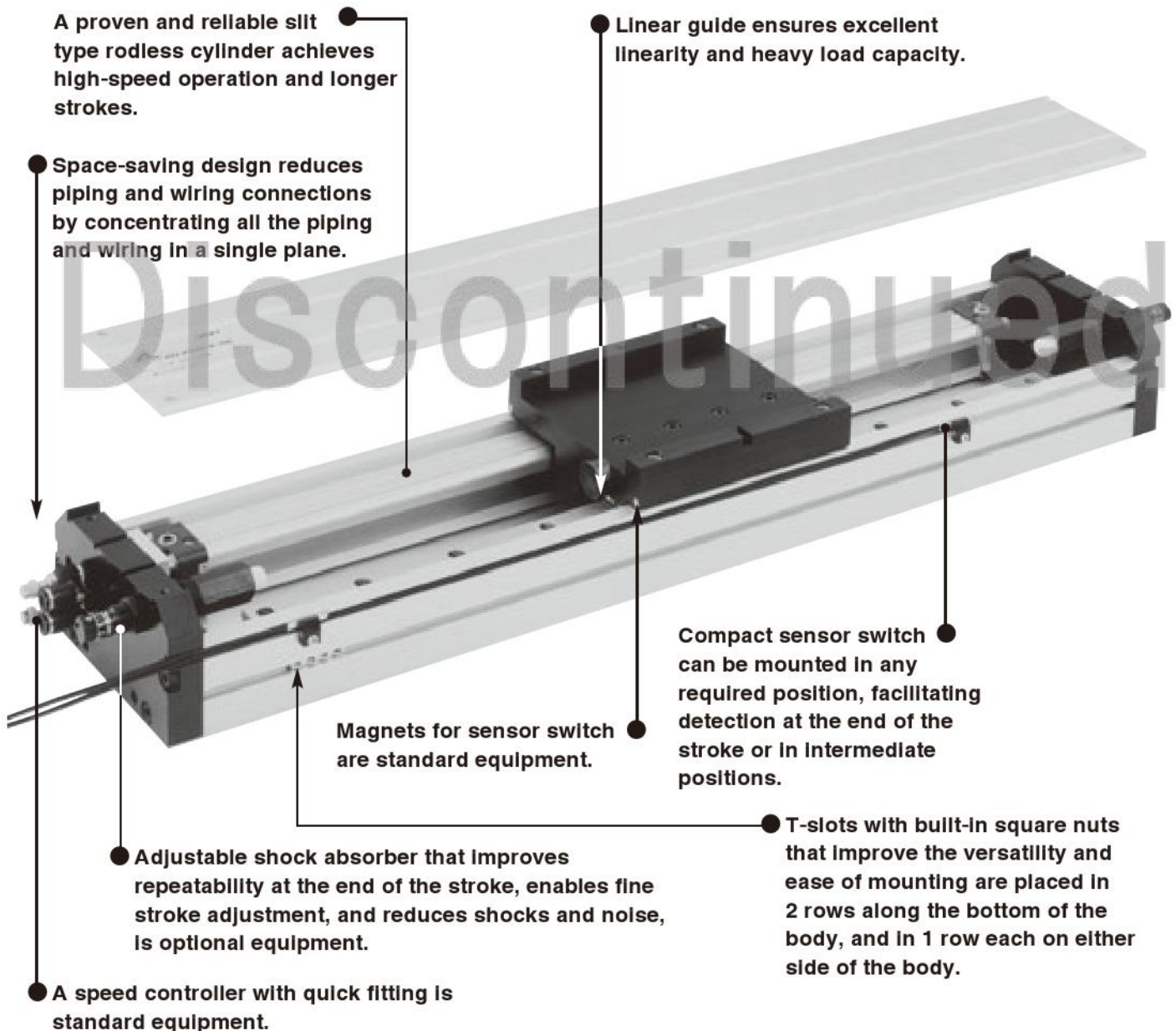

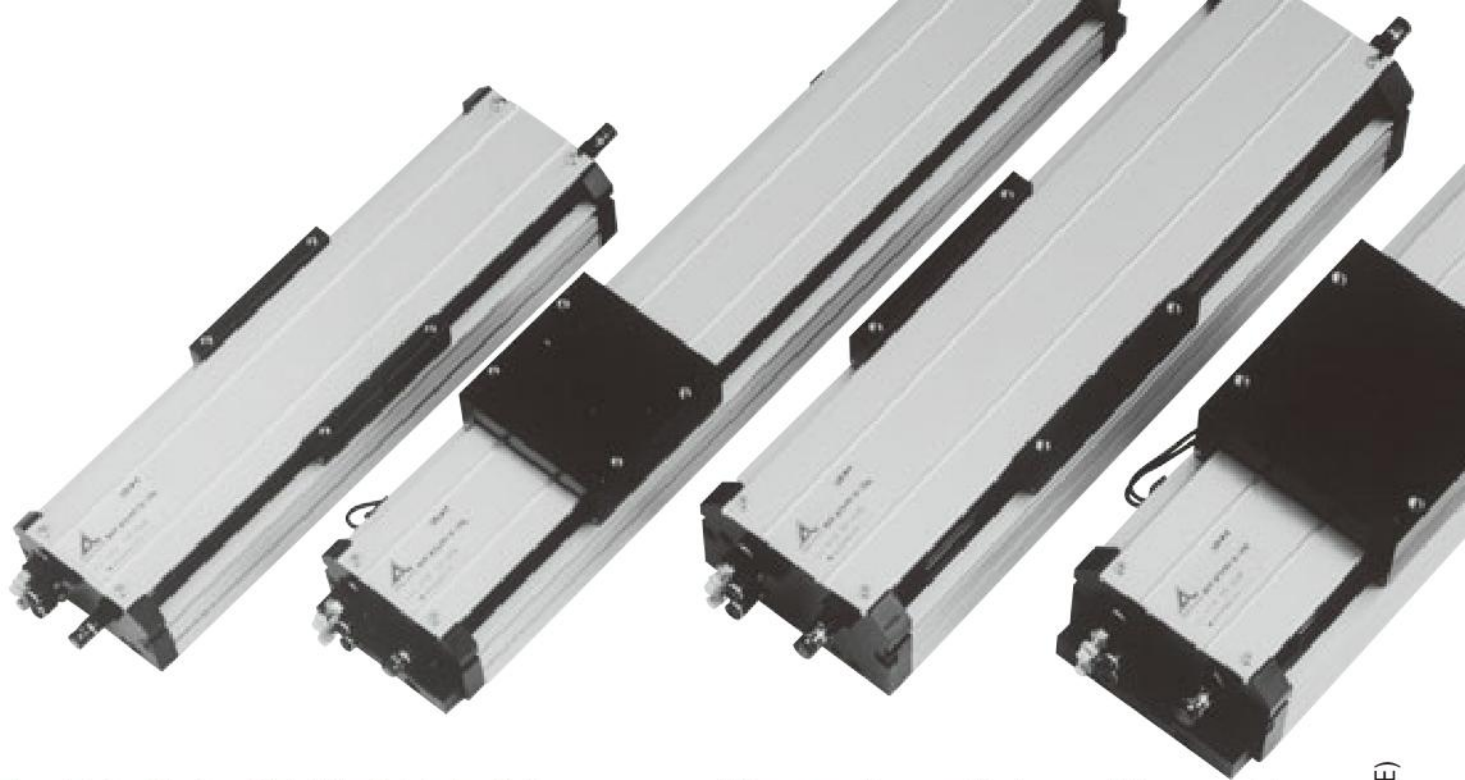

The Alpha Series RT slide table installs a proven slit type rodless cylinder and linear guide within a slim, thin-type body. This high-performance actuator offers superior positioning accuracy, linearity, and heavy load capacity.

RT SLIDE TABLES (B TYPE)

Cylinder offers reliability, high-speed operation, and longer strokes.

The actuator uses a highly reliable slit type rodless cylinder. Standard type offers long strokes of up to 1200mm (with bore size of $\phi 25$ [0.984in.]). Moreover, a fast operating speed range of 200~1000mm/s [7.9~39.4in./sec.] brings about a highly effective system with faster cycle time.



Adjustable shock absorber which enables high-speed operation is optional equipment.

The repeatability at the end of the stroke has been further improved, and an adjustable shock absorber that greatly reduces shock and noise is optional equipment.

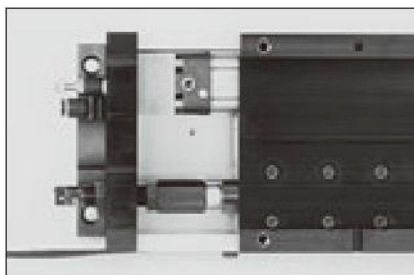

Concentrated placement of piping and wiring offers space-saving design.

The air piping connection port and the wiring outlet for the sensor switch are concentrated on a single plane, while a speed controller with quick fitting is standard equipment, for compact piping and wiring that allows rational space-saving equipment design.



Instantly and easily responds to more flexible and accurate drive controls.

Because built-in magnets for sensor switch are standard, mounting a sensor switch in a required position is all that is needed to enable detection at the end of the stroke or intermediate position.

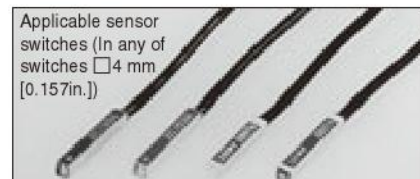

Model	Type	Indicator lamp	Voltage
ZC130□	Solid state type	Available	DC10~28V
ZC153□	Solid state type	Available	DC4.5~28V
CS5T□	Reed switch type	Not available	DC5~28V AC85~115V
CS11T□	Reed switch type	Available	DC10~28V

High precision linear guide offers heavy load capacity and high linearity.

High precision linear guide is installed within a flat and compact body. Responds to large loads and bending moment to ensure high linearity.

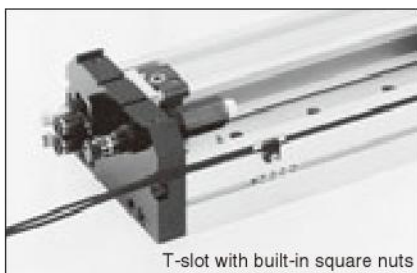
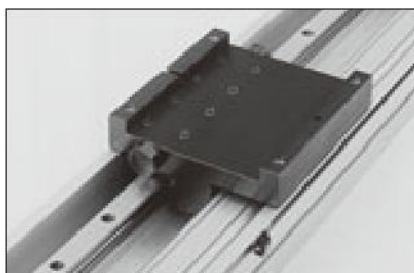

T-slot with built-in square nuts

RT SLIDE TABLES

Specifications

Item		Model	ARTB16	ARTB25
Bore size	mm [in.]		16 [0.630]	25 [0.984]
Operation type			Double acting type	
Media			Air	
Operating pressure range	MPa [psi.]		0.15~0.8 [22~116]	
Proof pressure	MPa [psi.]		1.2 [174]	
Operating temperature range	°C [°F]		0~60 [32~140]	
Operating speed range	mm/s [in./sec.]		200~1000 [7.9~39.4]	
Cushion	Standard		Variable cushion (Stroke ϕ 16 : 6mm [0.236in.], ϕ 25 : 17mm [0.669in.])	
	Option		Shock absorber	
Lubrication	Cylinder portion		Not required	
	Guide portion		Required (Lithium soap-based grease) ^{Note1}	
Repeatability	mm [in.]		± 0.05 [± 0.002]	
Parallelism ^{Note2}	mm [in.]		0.2 [0.008]	
Stroke adjusting range	mm [in.]		$-22\sim 0$ [$-0.866\sim 0$] (To the specified stroke, 11 [0.433] on each side)	$-26\sim 0$ [$-1.024\sim 0$] (To the specified stroke, 13 [0.512] on each side)
Maximum load capacity ^{Note3}	N [lbf.]		196.1 [44.1]	294.2 [66.1]
Applicable tube size for speed controller			ϕ 4	ϕ 6

Notes: 1. Apply lithium soap-based grease on the raceway surface of the track rail every 6 months or every 300km [186mi.] of traveling distance.

2. This is the parallelism between the table's upper surface and the bottom surface of the body. It is not the same as the traveling parallelism.

3. This shows the maximum load capacity values with the installation of shock absorbers. For details, see the shock absorber capacity graph on p.1011.

Shock Absorber Specifications

Item		Model	KSH6×10-S	KSH8×10C-S
Applicable cylinder			ARTB16	ARTB25
Maximum absorption	J [ft.lbf]		2.9 [2.14]	5.9 [4.35]
Absorbing stroke	mm [in.]		10 [0.394]	
Maximum impact speed	mm/s [in./sec.]		1000 [39.4]	
Maximum operating frequency	cycle/min		30	
Spring return force (At the retracted position)	N [lbf.]		9.2 [2.07]	15.7 [3.53]
Angle variation			3° or less	
Operating temperature range	°C [°F]		0~60 [32~140]	

Order Codes

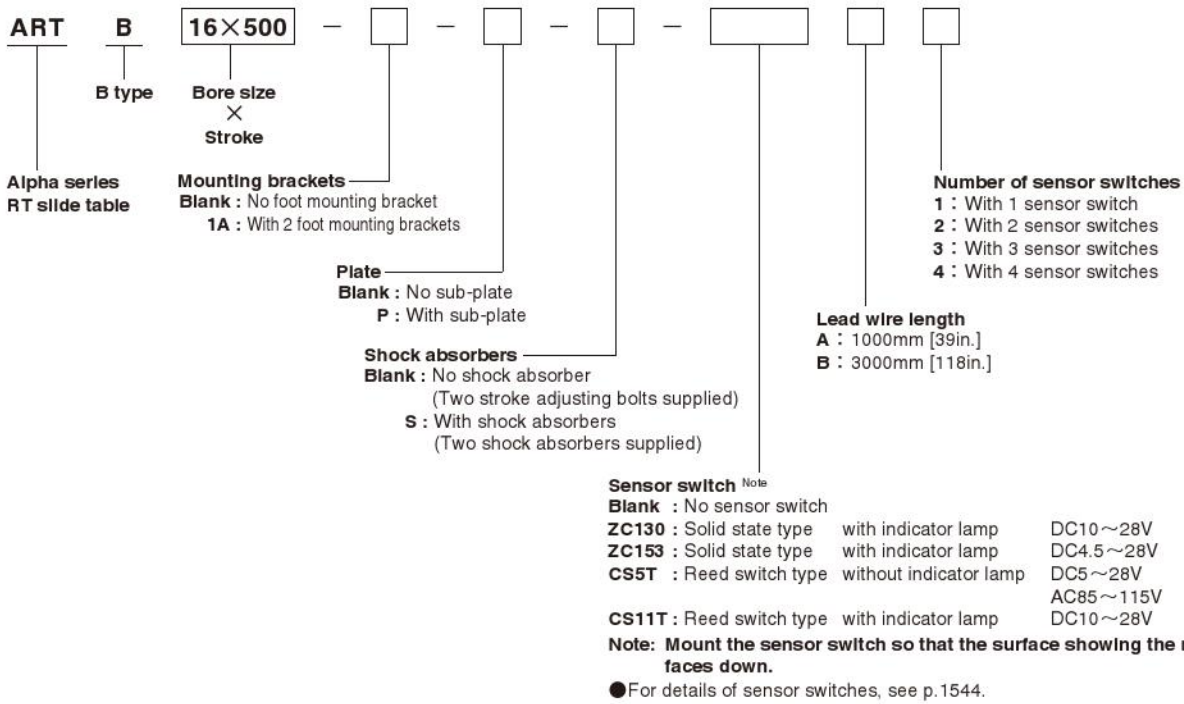

Order codes for options only

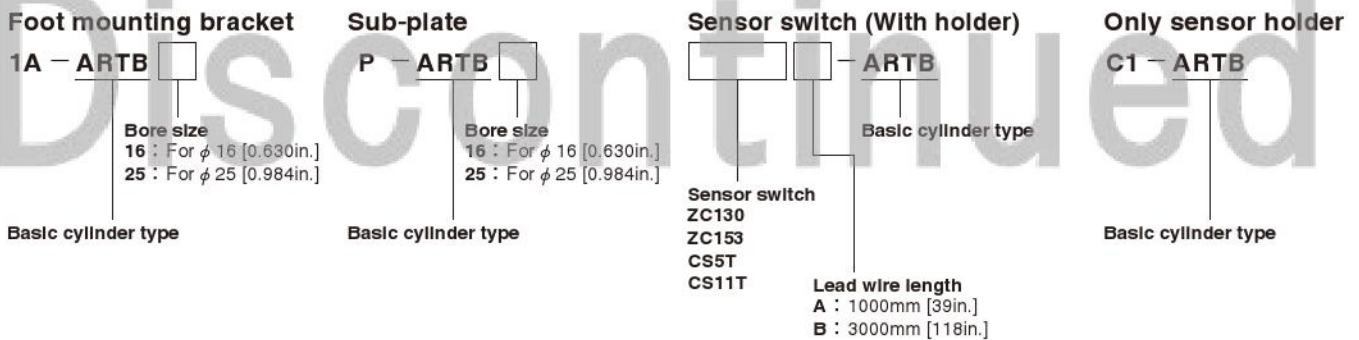

Shock absorber (With stopper nut)

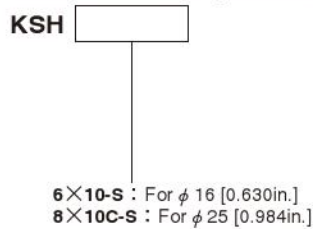

Bore Size and Stroke

mm	
Bore size	Standard strokes
16	200, 250, 300, 350, 400, 450, 500, 550, 600, 800, 1000
25	200, 250, 300, 350, 400, 450, 500, 550, 600, 800, 1000, 1200

Mass

● Mass of slide table

		g [oz.]					
Bore size mm	Stroke mm	200	250	300	350	400	450
	16		4230 [149.2]	4610 [162.6]	4980 [175.7]	5360 [189.1]	5730 [202.1]
25		8960 [316.0]	9600 [338.6]	10240 [361.2]	10880 [384.1]	11530 [406.7]	12180 [429.6]

		g [oz.]					
Bore size mm	Stroke mm	500	550	600	800	1000	1200
	16		6480 [228.8]	6860 [242.0]	7230 [255.0]	8730 [307.9]	10230 [360.8]
25		12810 [451.9]	13460 [474.8]	14090 [497.0]	16660 [587.7]	19230 [678.3]	21800 [769.0]

● Additional mass of options

Shock absorbers (for 2 pcs.)

Bore size mm [in.]	Mass
16 [0.630]	25 [0.88]
25 [0.984]	55 [1.94]

The above table shows the additional mass to the standard products with stroke adjusting bolts.

Foot mounting brackets (for 2 pcs.)

Bore size mm [in.]	Mass
16 [0.630]	115 [4.06]
25 [0.984]	260 [9.17]

Plate

Bore size mm [in.]	Mass
16 [0.630]	390 [13.76]
25 [0.984]	1040 [36.68]

Sensor switch (for 1 pc.)

Model	Mass
ZC130□	20 [0.71]
ZC153□	20 [0.71]
CS5T□	20 [0.71]
CS11T□	20 [0.71]

Shock Absorber Capacity Graph

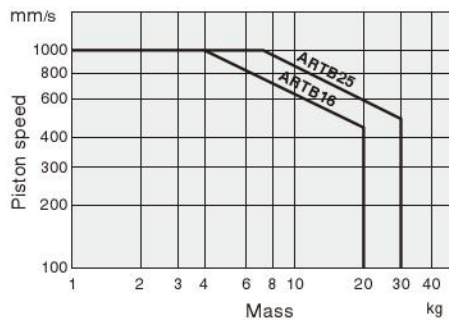

1mm/s = 0.0394in./sec.
1kg = 2.205lb.

Allowable Bending Moment and Displacement

● Allowable bending moment

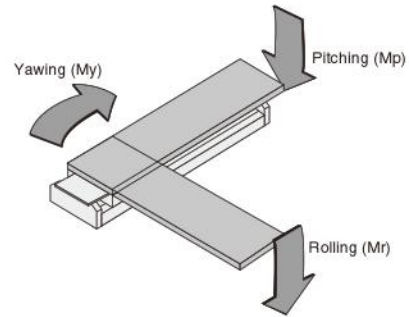

		N·m [ft·lbf]		
Bore size mm [in.]	Direction of moment	Pitching (Mp)	Yawing (My)	Rolling (Mr)
	16 [0.630]		14.7 [10.8]	14.7 [10.8]
25 [0.984]		29.4 [21.7]	29.4 [21.7]	29.4 [21.7]

● Table end displacement at allowable bending moment

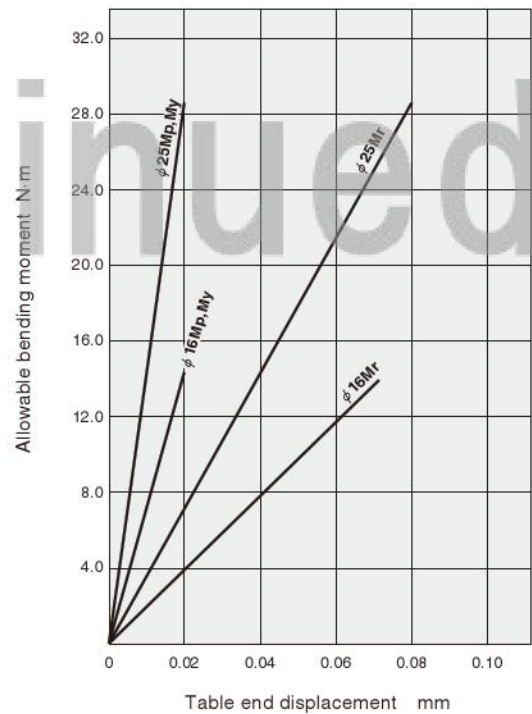

1N·m = 0.7376ft·lbf
1mm = 0.0394in.

Dimensions of ARTB16 (mm)

● $\phi 16$ [0.630in.] ● Maximum load capacity 196.1N [44.1lbf.] (With shock absorbers)



● Drawings show specification strokes.

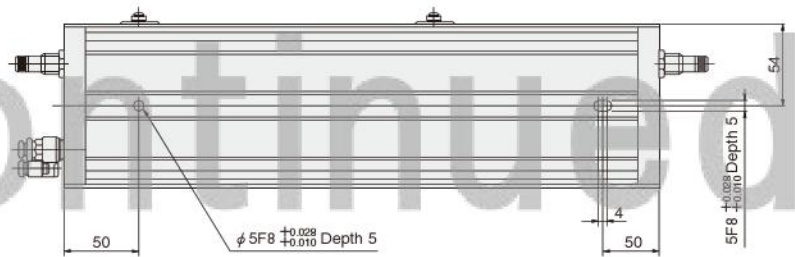
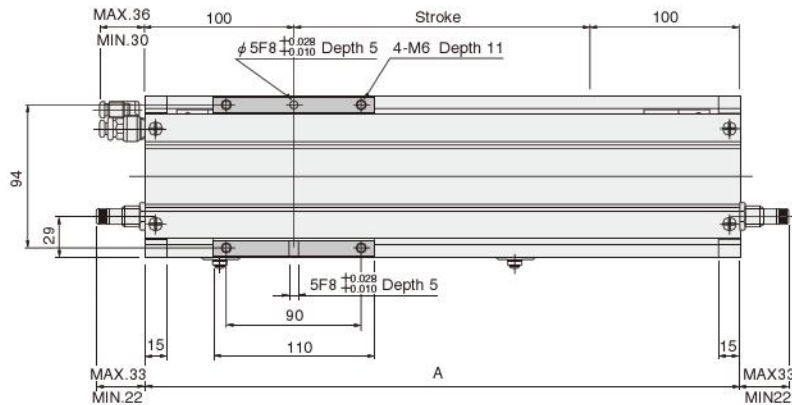
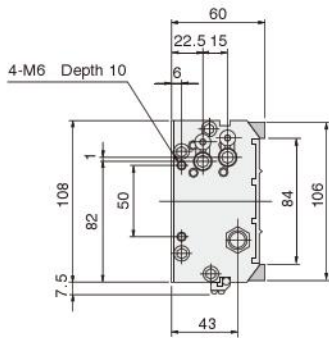

Stroke	Code	A	N
200		400	4
250		450	4
300		500	6
350		550	6
400		600	6
450		650	6
500		700	6
550		750	6
600		800	8
800		1000	8
1000		1200	10

Stroke adjusting bolt (standard)

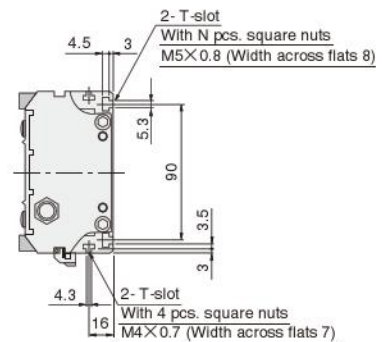
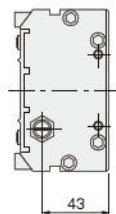
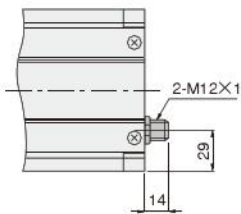

Sub-plate: -P



Foot mounting bracket: -1A

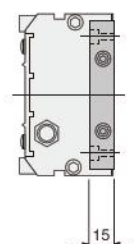
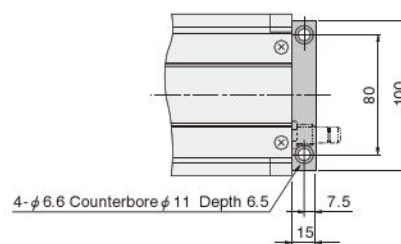
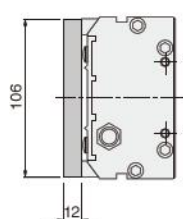
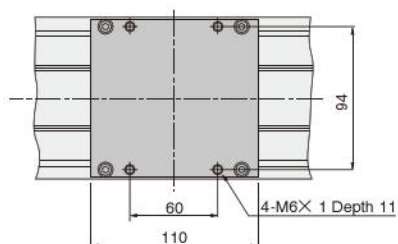

RT SLIDE TABLES (B TYPE)

Dimensions of ARTB25 (mm)

● $\phi 25$ [0.984In.] ● Maximum load capacity 294.2N [66.11bf.] (With shock absorbers)



● Drawings show specification strokes.

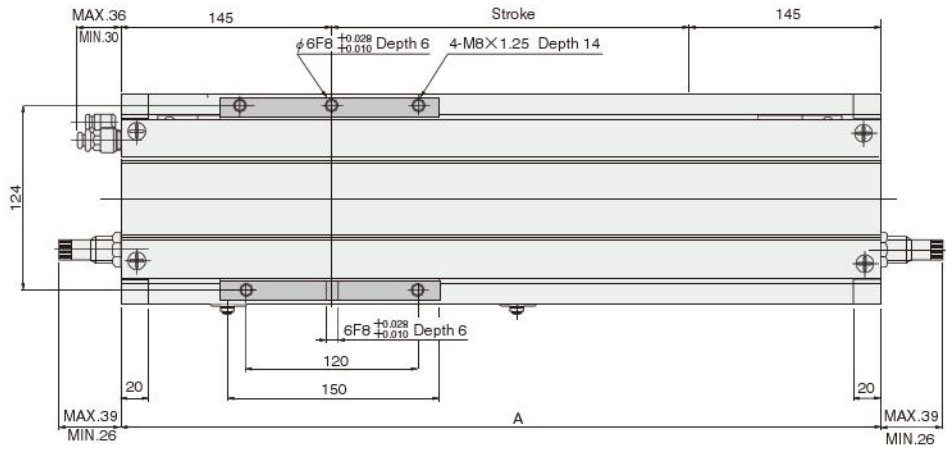
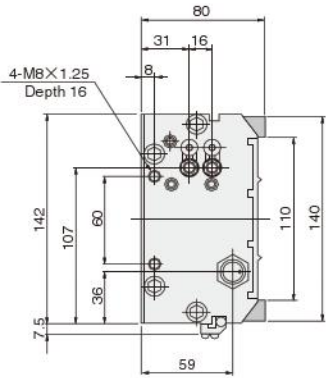

Stroke	Code	A	N
200		490	4
250		540	4
300		590	4
350		640	6
400		690	6
450		740	6
500		790	6
550		840	6
600		890	6
800		1090	8
1000		1290	8
1200		1490	10

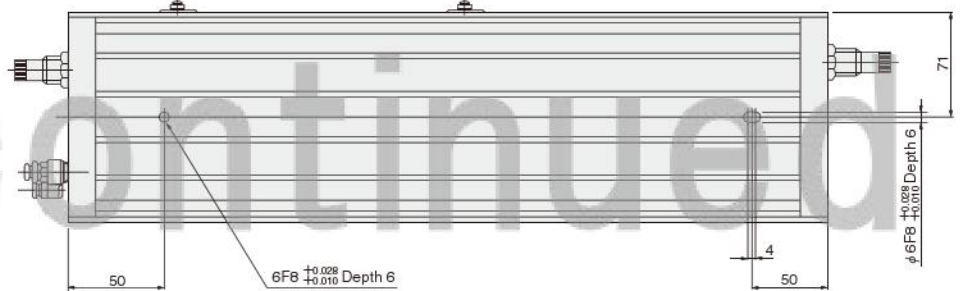
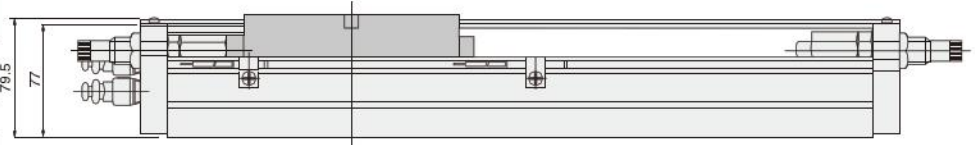

Stroke adjusting bolt (standard)

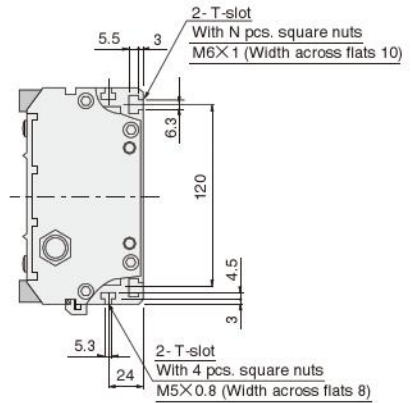
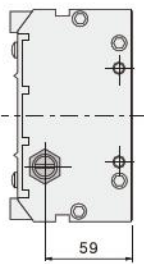
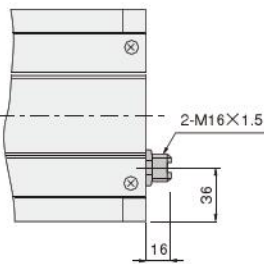

Sub-plate: -P

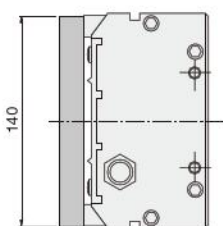
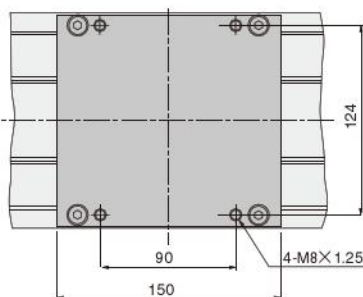

Foot mounting bracket: -1A

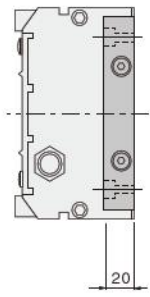
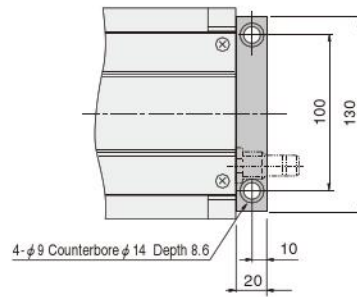

Handling Instructions and Precautions



Sensor switch

Mounting location of end of stroke detection sensor switch

When the sensor switch is mounted in the locations shown below (the figures in the table are reference values), the magnet comes to the maximum sensing location of the sensor switch at the end of the stroke.

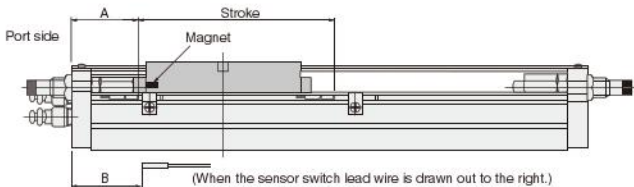

mm [in.]

Sensor switch	ARTB16		ARTB25	
	A	B	A	B
ZC130, ZC153	31.5 [1.240]	39.5 [1.555]	56.5 [2.224]	64.5 [2.539]
CS5T	33 [1.299]	41 [1.614]	58 [2.283]	66 [2.598]
CS11T	32.5 [1.280]	37.5 [1.476]	57.5 [2.264]	62.5 [2.461]

Caution: Mount the sensor switch so that the surface showing the model marking faces down.



General precautions

Piping

Always thoroughly blow off (use compressed air) the tubing before connecting it to the RT slide table. Entering chips, sealing tape, rust, etc., generated during piping work could result in air leaks or other defective operation.

Atmosphere

Do not engage in electric welding close to the RT slide table. The welding spatters could damage the outer seal band. The product cannot be used when the media or ambient atmosphere contains any of the substances listed below. Organic solvents, phosphate ester type hydraulic oil, sulphur dioxide, chlorine gas, or acids, etc.

Lubrication

The product can be used without lubrication, if lubrication is required, use Turbine Oil Class 1 (ISO VG32) or equivalent.

Media

1. Use air for the media. For the use of any other media, consult us.
2. Air used for the RT slide table should be clean air that contains no deteriorated compressor oil, etc. Install an air filter (filtration of a minimum 40 µm) near the RT slide table or valve to remove collected liquid or dust. In addition, drain the air filter periodically.

Maintenance

The RT slide table is structurally incapable of completely preventing air leakage to the outside. Nevertheless, particles adhering to the inner seal band are the most common cause of initial-stage air leakages, and this type of failure is easily remedied. First, loosen the outer seal band setscrews, remove the outer seal band, and apply approx. 0.1MPa [15psi.] of air pressure to the RT slide table. Next, insert a cleaning tool inside the cylinder barrel slit and then, while pressing down on the inner seal band and moving it along the slit, use air to blow off the particles.

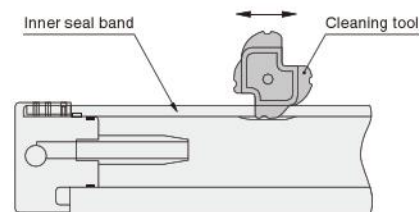

- Cautions:**
1. Always wear protective glasses during operations.
 2. When performing maintenance, use the special cleaning tool provided. Use of a screwdriver or other tool could damage the inner seal band or cylinder barrel.
 3. If the above maintenance fails to stop the air leakage, follow instructions in the user's manual to perform a overhaul.

RT SLIDE TABLES (B TYPE)

Discontinued