



# ROD SLIDERS

The Alpha Series rod slider combines a twin rod cylinder and guides into the compact slide table, and is a state-of-the-art actuator that achieves high accuracy, high rigidity, and high thrust.

*See the wonders of our rod slider before your very eyes!*

## ● Two guides for reliable design!!

(One guide for  $\phi 6$  [0.236in.])

Two LM guides are used to achieve high accuracy and high rigidity.

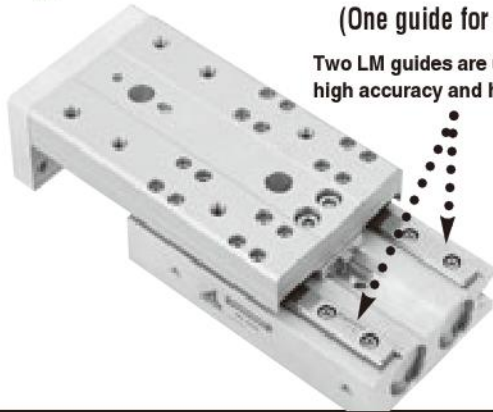

## ● Stopper at center line configuration!!

(Side stopper for  $\phi 6$  [0.236in.])

Stopper located in the center line greatly reduces table eccentricity to achieve stable accuracy.

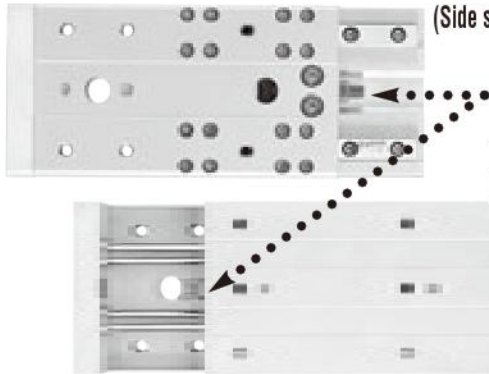

## ● Heli-sert added to mounting thread!!

(Except for  $\phi 6$  [0.236in.])

Heli-sert reinforces the mounting thread strength.

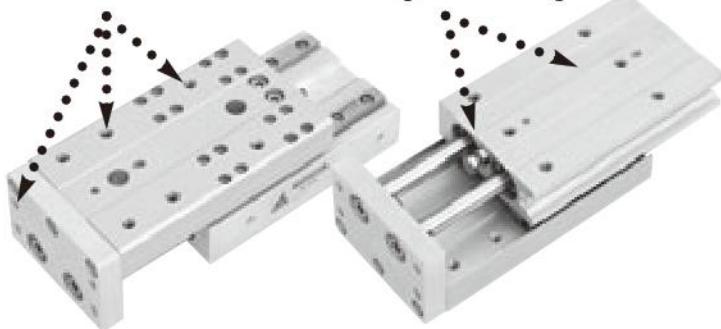

# Alpha Rod slider

### ◆ Application example 1

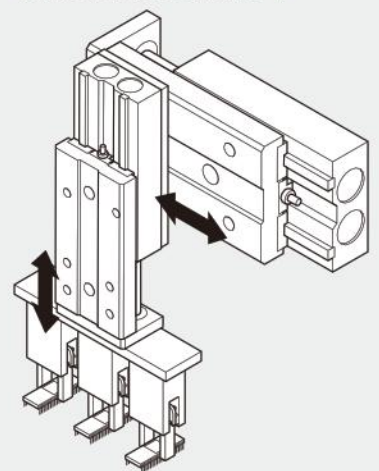

## Optimum for Z axis

### ■ Cylinder with shock absorbers

( $\phi$  10, 16, 20, 25 [0.394, 0.630, 0.787, 0.984in.])



### ■ End keep cylinder

( $\phi$  16, 20, 25 [0.630, 0.787, 0.984in.])



### ● Twin rod ensures high thrust!!

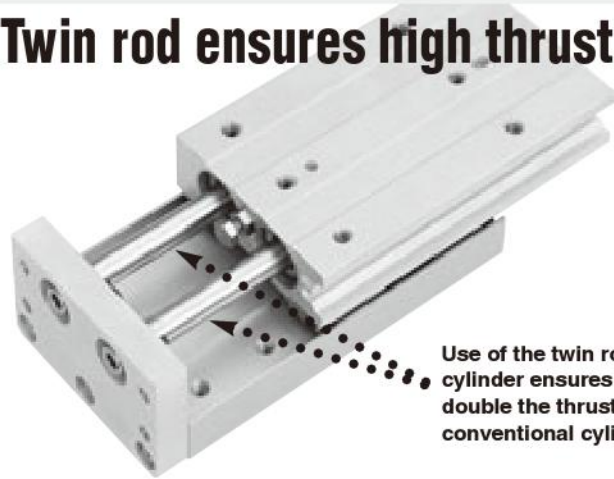

Use of the twin rod cylinder ensures double the thrust of conventional cylinders.

### ● Locating dowel pin holes already prepared!!

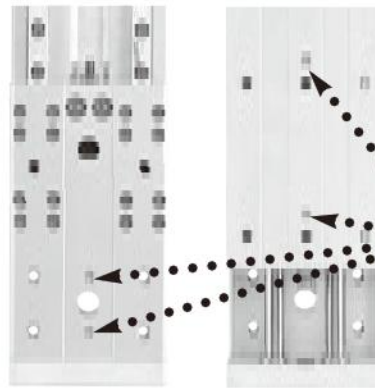

Locating dowel pin holes are prepared to ensure the repeatability of mounting and removing.

### ◆ Application example 2

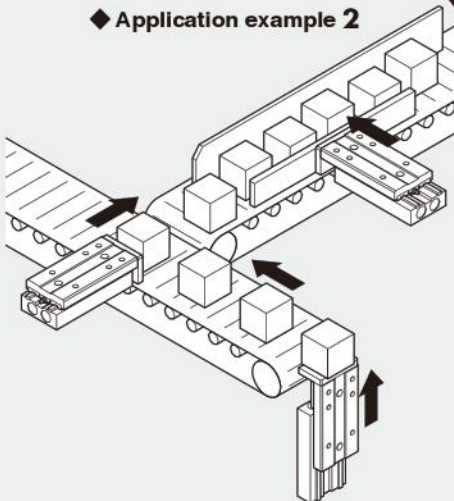

### ● Embedded type sensor switch!!



Embedded type sensor switches can be installed.

※ Sensor switch is optional.

# Alpha Rod slider

# VARIATIONS

*Three variations are offered, depending on the application.*

## LINE UP

	Bore size mm [in.]	6	10	16	20	25
Specification		[0.236]	[0.394]	[0.630]	[0.787]	[0.984]
Standard cylinders		●	●	●	●	●
Cylinders with shock absorbers		—	●	●	●	●
End keep cylinders		—	—	●	●	●

### ● Standard Cylinders

The standard type rod slider achieves high accuracy, high rigidity, and high thrust.

Specifications P. 899

Order codes P. 900

Dimensions P. 901



### ● Cylinders with Shock Absorbers

A shock absorber for reducing shocks at the end of the stroke is standard equipment.

(Note: Not available for  $\phi 6$  [0.236in.])

Specifications P. 906

Order codes P. 907

Dimensions P. 909



### ● End Keep Cylinders

Comes with an end keep mechanism to prevent unintended falling the table attaching parts due to a cut-off of the air supply, or a reduction in air pressures.

(Note: Not available for  $\phi 6$  [0.236in.] and  $\phi 10$  [0.394in.])

Specifications P. 913

Order codes P. 914

Dimensions P. 915



## Handling Instructions and Precautions



### General precautions

#### Media

1. Always thoroughly blow off (use compressed air) the tubing before piping. Entering chips, sealing tape, rust, etc., generated during piping work could result in air leaks or other defective operation.
2. Use air for the media. For the use of any other media, consult us.
3. Air used for the cylinder should be clean air that contains no deteriorated compressor oil, etc. Install an air filter (filtration of a minimum 40  $\mu\text{m}$ ) near the cylinder or valve to remove collected liquid or dust. In addition, drain the air filter periodically. Collected liquid or dust entering the cylinder may cause improper operation.

#### Lubrication

1. The product can be used without lubrication, if lubrication is required, use Turbine Oil Class 1 (ISO VG32) or equivalent. Avoid using spindle oil or machine oil.
2. Apply lithium soap-based grease on the raceway surface of the track rail in the guide portion every 6 months or every 300km [186mi.] of traveling distance.

#### Atmosphere

If using in locations subject to dripping water, dripping oil, etc., or to large amounts of dust, use a cover to protect the unit.



### Mounting and stroke adjustment

#### Mounting

1. While any mounting direction is allowed, the mounting surface should always be flat. Twisting or bending during mounting may disturb the accuracy and may also result in air leaks or improper operation.
2. Caution should be exercised that scratches or dents on the Rod Slider's mounting surface may damage its flatness.
3. In applications subject to large shocks, reinforcing the bolt mounting, by installing a support to the Rod Slider body for example, is recommended.
4. Ensure that the selected Rod Slider body and mounting bolts have sufficient strength.
5. Install stoppers or take other measures when shocks or vibrations might loosen the bolts.
6. Do not leave scratches or dents in the areas where the piston rod contacts. It could result in damage to the seal or in air leaks.



## Mounting and stroke adjustment

### Stroke adjustment

#### 1. Standard cylinder and end keep cylinder

In the standard cylinders, the stroke can be easily adjusted on both the extended and retracted sides within a range of  $-5 \sim 0\text{mm}$  [ $-0.197 \sim 0\text{in.}$ ], while in the end keep cylinders they can be adjusted on the extended sides only within a range of  $-5 \sim 0\text{mm}$  [ $-0.197 \sim 0\text{in.}$ ].

For the retracted side adjustment, turning to the left (counterclockwise) of the stopper bolt for retracted side stroke adjustment shortens the stroke. For the extended side adjustment, turning the stopper bolt to the right (clockwise) shortens the stroke.

After adjustment, tighten the locknut and secure it in place. The stroke at shipping is set to the standard stroke. Do not adjust it to larger than the standard stroke.

#### 2. Cylinder with shock absorber

In cylinders with shock absorbers (ARSZ), the stroke can be adjusted by using the stopper bolt or shock absorber.

If the stopper bolt is used for stroke adjustment, leave a clearance of  $0 \sim 0.5\text{mm}$  [ $0 \sim 0.020\text{in.}$ ] between the stopper block and shock absorber after completing adjustment with the stopper bolt, as shown in the diagram below. An adjustment to more than  $0.5\text{mm}$  [ $0.020\text{in.}$ ] will greatly reduce the shock absorber's absorption capacity. If the shock absorber is used for stroke adjustment, contact the shock absorber directly with the stopper block to make the adjustment. The stroke at shipping is set to the standard stroke. Do not adjust it to larger than the standard stroke.

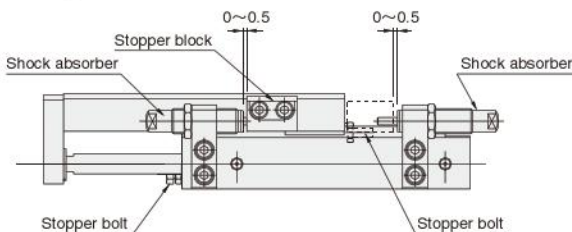

## Control circuit for the end keep cylinder

1. For control of the Rod Slider End Keep Cylinder, we recommend the use of 2-position, 4-, 5-port valves. Avoid the use of control circuit with ABR connection (exhaust center) 3-position valves that exhaust air from 2 delivery ports.
2. Always use meter-out control for speed adjustment. Meter-in control may result in failure of the locking mechanism to release.
3. Always set the air pressure to  $0.2\text{MPa}$  [ $29\text{psi.}$ ] or more.

- Cautions:**
1. It is dangerous to supply air to a connection port on a side with a locking mechanism while the cylinder has already been exhausted, because the piston rod may suddenly extend, etc. In addition, since the lock piston could also cause galling of the lock piston and piston rod, resulting in defective operation. Always supply air to the connection port opposite the one adjacent to the locking mechanism to ensure applying back pressure.
  2. When restarting operations after air has been exhausted from the cylinder due to completion of operations or to an emergency stop, always start by supplying air to the connection port opposite the one adjacent to the locking mechanism.
  3. Connect the valve port A (NC) to the connection port on the side with the locking mechanism.



## Manual operation of locking mechanism

While the locking mechanism is normally released automatically through cylinder operations, it can also be released manually. For manual release, insert an  $\text{M}3 \times 0.5$  screw that has  $30\text{mm}$  [ $1.18\text{in.}$ ] screw length into the opening for manual override, thread it in about 3 turns into the internal lock piston, and then pull up the screw. To maintain the manual override for adjustment, etc., thread the locknut onto the screw and, with the locking mechanism in a released state, tighten the locknut against the cylinder.

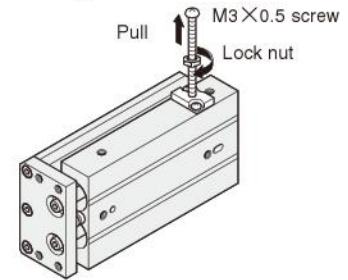

- Cautions:**
1. It is dangerous to release the lock when load (weight) is present on the piston rod, because it may cause the unintended piston rod's extension, etc. In this case, always supply air to the connection port opposite the one adjacent to the locking mechanism before releasing the locking mechanism.
  2. If the locking mechanism cannot easily be released even with manual override, it could be the result of galling of the lock piston and piston rod. In this case, supply air to the connection port opposite the one adjacent to the locking mechanism before releasing the locking mechanism.
  3. Water, oil, dust, etc., intruding through the opening for manual override may cause defective locks or other erratic operation. If using in locations subject to dripping water, dripping oil, etc., or large amounts of dust, use a cover to protect the unit.

### 3. Tightening torque of the locknut

Before use and after stroke adjustment, secure the locknut with the tightening torque shown below.

Do not tighten to more than the torque shown below, as such action could damage the unit.

Bore size mm [in.]	Locknut for retracted side stopper bolt		Locknut for extended side stopper bolt		Locknut for shock absorber	
	Tightening torque N·m [in·lbf]	Nut	Tightening torque N·m [in·lbf]	Nut	Tightening torque N·m [in·lbf]	Nut
6 [0.236]	0.98 [8.7]	M3×0.5	0.98 [8.7]	M3×0.5	—	—
10 [0.394]	0.98 [8.7]	M3×0.5	1.37 [12.1]	M4×0.7	2.45 [21.7]	M8×0.75
16 [0.630]	1.37 [12.1]	M4×0.7	1.37 [12.1]	M4×0.7	6.37 [56.4]	M10×1
20 [0.787]	2.84 [25.1]	M5×0.8	2.84 [25.1]	M5×0.8	11.77 [104.2]	M12×1
25 [0.984]	2.84 [25.1]	M5×0.8	4.80 [42.5]	M6×1	11.77 [104.2]	M12×1

# Cylinder Thrust

When carrying a load, the load value should be the maximum load capacity or below, and set the load ratio (load ratio =  $\frac{\text{Load}}{\text{Calculated value}}$ ), where the calculated values are shown in the table, to 50% or less when the mounting direction is vertical, and to 70% or less when the mounting direction is horizontal.

Bore size mm [in.]	Rod diameter mm [in.]	Operation	Pressure area mm <sup>2</sup> [in. <sup>2</sup> ]	Air pressure MPa						
				0.2 [29]	0.3 [44]	0.4 [58]	0.5 [73]	0.6 [87]	0.7 [102]	
<b>6 [0.236]</b>	4 [0.157]	Double acting type	Push side	56 [0.087]	11.2 [2.52]	16.8 [3.78]	22.4 [5.04]	28.0 [6.29]	33.6 [7.55]	39.2 [8.81]
			Pull side	31 [0.048]	6.2 [1.39]	9.3 [2.09]	12.4 [2.79]	15.5 [3.48]	18.6 [4.18]	21.7 [4.88]
<b>10 [0.394]</b>	6 [0.236]	Double acting type	Push side	157 [0.243]	31.4 [7.06]	47.1 [10.59]	62.8 [14.12]	78.5 [17.65]	94.2 [21.18]	109.9 [24.71]
			Pull side	100 [0.155]	20.0 [4.50]	30.0 [6.74]	40.0 [8.99]	50.0 [11.24]	60.0 [13.49]	70.0 [15.74]
<b>16 [0.630]</b>	8 [0.315]	Double acting type	Push side	402 [0.623]	80.4 [18.07]	120.6 [27.11]	160.8 [36.15]	201.0 [45.18]	241.2 [54.22]	281.4 [63.26]
			Pull side	301 [0.467]	60.2 [13.53]	90.3 [20.30]	120.4 [27.07]	150.5 [33.83]	180.6 [40.60]	210.7 [47.37]
<b>20 [0.787]</b>	10 [0.394]	Double acting type	Push side	628 [0.973]	125.6 [28.23]	188.4 [42.35]	251.2 [56.47]	314.0 [70.59]	376.8 [84.70]	439.6 [98.82]
			Pull side	471 [0.730]	94.2 [21.18]	141.3 [31.76]	188.4 [42.35]	235.5 [52.94]	282.6 [63.53]	329.7 [74.12]
<b>25 [0.984]</b>	12 [0.472]	Double acting type	Push side	981 [1.521]	196.2 [44.11]	294.3 [66.16]	392.4 [88.21]	490.5 [110.26]	588.6 [132.32]	686.7 [154.37]
			Pull side	755 [1.170]	151.0 [33.94]	226.5 [50.92]	302.0 [67.89]	377.5 [84.86]	453.0 [101.83]	528.5 [118.81]

N [lbf.]

ROD SLIDERS

## Allowable Bending Moment

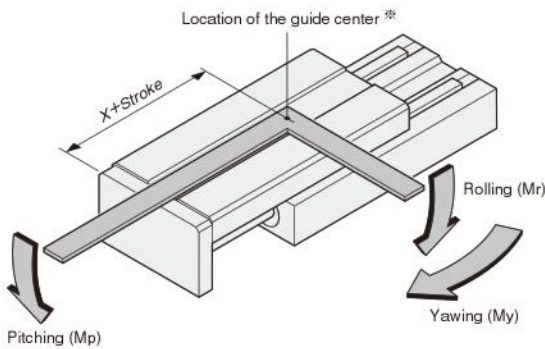

※ Use the location of the guide center in the diagram as the reference position for determining the moment center.

Bore size mm [in.]	Allowable moment		
	Mp (Pitching)	Mr (Rolling)	My (Yawing)
<b>6 [0.236]</b>	2.0 [1.48]	1.0 [0.74]	2.0 [1.48]
<b>10 [0.394]</b>	7.0 [5.16]	7.0 [5.16]	7.0 [5.16]
<b>16 [0.630]</b>	9.0 [6.64]	9.0 [6.64]	9.0 [6.64]
<b>20 [0.787]</b>	14.0 [10.33]	16.0 [11.80]	14.0 [10.33]
<b>25 [0.984]</b>	18.0 [13.28]	20.0 [14.75]	18.0 [13.28]

Bore size	mm [in.]	
	Code	X
<b>6 [0.236]</b>		43 [1.69]
<b>10 [0.394]</b>		43 [1.69]
<b>16 [0.630]</b>		48 [1.89]
<b>20 [0.787]</b>		60 [2.36]
<b>25 [0.984]</b>		60 [2.36]

## Square Plate End Eccentricity (Reference Value)

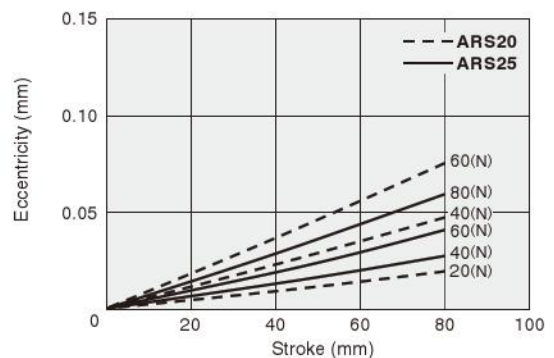
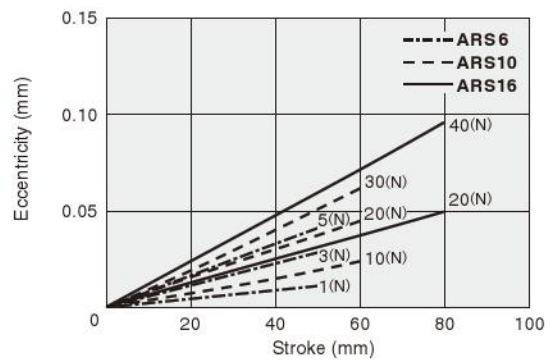
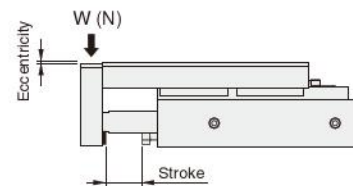

1mm = 0.0394in.

# ROD SLIDERS

## Standard Cylinders



### Symbol

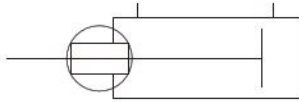

### Bore Size and Stroke

mm		
Bore size	Standard strokes	Maximum available stroke <sup>Note</sup>
6	10, 20, 30, 40, 50	70
10	10, 20, 30, 40, 50, 60	100
16	10, 20, 30, 40, 50, 60, 80	120
20	10, 20, 30, 40, 50, 60, 80	150
25	10, 20, 30, 40, 50, 60, 80	150

Note: For non-standard strokes, see p.920.

### Specifications

Model		ARS6	ARS10	ARS16	ARS20	ARS25
Item	mm [in.]	6 [0.236]	10 [0.394]	16 [0.630]	20 [0.787]	25 [0.984]
Operation type		Double acting type				
Media		Air				
Operating pressure range	MPa [psi.]	0.2~0.7 [29~102]				
Proof pressure	MPa [psi.]	1.03 [149]				
Operating temperature range	°C [°F]	0~60 [32~140]				
Operating speed range	mm/s [in./sec.]	150~500 [5.9~19.7]		100~500 [3.9~19.7]		
Cushion		Rubber bumper				
Lubrication	Cylinder portion	Not required (If lubrication is required, use Turbine Oil Class 1 [ISO VG32] or equivalent.)				
	Guide portion	Required (Lithium soap-based grease) <sup>Note1</sup>				
Repeatability	mm [in.]	±0.05 [±0.002]				
Traveling parallelism	mm [in.]	0.1 [0.004]				
Square plate perpendicularity	mm [in.]	0.1 [0.004]				
Stroke adjusting range <sup>Note2</sup>	mm [in.]	Extended side: -5~0 [-0.197~0] Retracted side: -5~0 [-0.197~0]				
Maximum load capacity	N [lbf.]	4.9 [1.10]	29.4 [6.61]	39.2 [8.81]	58.8 [13.22]	78.5 [17.65]
Port size		M5×0.8				

Notes: 1. Apply grease on the raceway surface of the track rail every 6 months or every 300km [186mi.] of traveling distance.

2. For stroke adjustment, keep within the adjusting ranges shown above.

Remark: Stainless steel is used for the guides.

### Mass

● Main body mass			g [oz.]
Bore size mm [in.]	Zero stroke mass	Additional mass for each 10mm [0.394in.] stroke	
6 [0.236]	150 [5.29]	20 [0.71]	
10 [0.394]	315 [11.11]	35 [1.23]	
16 [0.630]	450 [15.87]	50 [1.76]	
20 [0.787]	765 [26.98]	85 [3.00]	
25 [0.984]	1295 [45.68]	105 [3.70]	

● Additional mass of option (1 sensor switch)		g [oz.]
Model	Mass	
ZE101, ZE102, ZE201, ZE202,	15 [0.53] (For a lead wire of 1000mm [39in.])	
ZE135, ZE155, ZE235, ZE255	35 [1.23] (For a lead wire of 3000mm [118in.])	

## Order Codes

**ARS**

**16 X 50**

- [ ] [ ] [ ] [ ]

Alpha series  
Rod slider  
standard cylinder

Bore size  
×  
Stroke

**Sensor switch**

- ZE101** : Reed switch type without indicator lamp
- ZE102** : Reed switch type with indicator lamp
- ZE201** : Reed switch type without indicator lamp
- ZE202** : Reed switch type with indicator lamp
- ZE135** : 2-lead wire Solid state type with indicator lamp
- ZE155** : 3-lead wire Solid state type with indicator lamp
- ZE235** : 2-lead wire Solid state type with indicator lamp
- ZE255** : 3-lead wire Solid state type with indicator lamp
- Blank** : No sensor switch

**Lead wire length**

- A** : 1000mm [39in.]
- B** : 3000mm [118in.]

**Number of sensor switches**

- 1** : With 1 sensor switch
- 2** : With 2 sensor switches
- 3** : With 3 sensor switches
- ⋮

- Horizontal lead wire DC5~28V, AC85~115V
- Horizontal lead wire DC10~28V, AC85~115V
- Vertical lead wire <sup>No.1</sup> DC5~28V, AC85~115V
- Vertical lead wire <sup>No.2</sup> DC10~28V, AC85~115V
- Horizontal lead wire DC10~28V
- Horizontal lead wire DC4.5~28V
- Vertical lead wire <sup>No.1</sup> DC10~28V
- Vertical lead wire <sup>No.2</sup> DC4.5~28V

Note: In the vertical lead wire type, the lead wire protrudes at a right angle to the sensor switch.  
● For details of sensor switches, see p.1544.

## Inner Construction

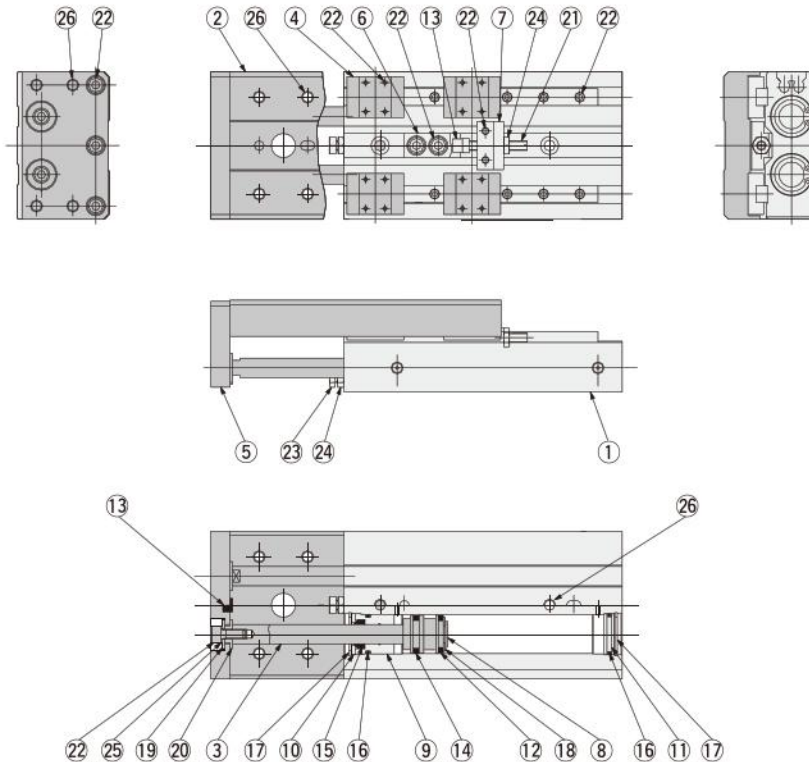

## Major Parts and Materials

No.	Parts	Materials	Remarks
①	Main body	Aluminum alloy (anodized)	
②	Table	Aluminum alloy (anodized)	
③	Piston rod	Steel (hard chrome plated)	Stainless steel for $\phi 6$ [0.236in.] Stainless steel (hard chrome plated) for $\phi 10$ [0.394in.]
④	Linear guide	Stainless steel	
⑤	Square plate	Aluminum alloy (anodized)	
⑥	Block	Aluminum alloy (anodized)	
⑦	Bracket	Aluminum alloy (anodized)	Not available for $\phi 6$ [0.236in.]
⑧	Piston	Aluminum alloy (chromic acid anodic oxide coating)	Brass for $\phi 6$ [0.236in.] only
⑨	Housing	Aluminum alloy (anodized)	
⑩	Seal holder	Mild steel (nickel plated)	Aluminum (anodized) for $\phi 6$ [0.236in.] only
⑪	End plate	Plastic	
⑫	Magnet	Sintered alloy magnet	

No.	Parts	Materials	Remarks
⑬	Bumper	Synthetic rubber (NBR)	
⑭	Piston seal	Synthetic rubber (NBR)	
⑮	Rod seal	Synthetic rubber (NBR)	
⑯	O-ring	Synthetic rubber (NBR)	
⑰	Snap ring	Steel (nickel plated)	
⑱	E-ring	Stainless steel	
⑲	Bolt retainer	Mild steel (nickel plated)	
⑳	Sleeve	Mild steel (nickel plated)	
㉑	Stopper bolt	Stainless steel (nickel plated)	For extended side stroke adjustment
㉒	Hexagon socket head bolt	Stainless steel, Steel (nickel plated)	
㉓	Stopper bolt	Stainless steel	For retracted side stroke adjustment
㉔	Nut	Stainless steel	
㉕	Washer	Steel (nickel plated)	Not available in $\phi 6$ [0.236in.]
㉖	Heli-sert	Stainless steel	Not available in $\phi 6$ [0.236in.]

Note: The shapes at  $\phi 6$  are different. (See dimensions)



# Dimensions of Rod Slider Standard Cylinder (mm)

● ARS10 × Stroke

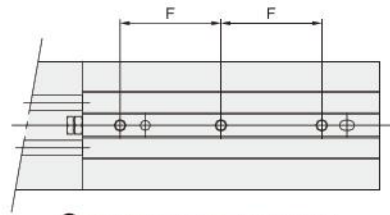
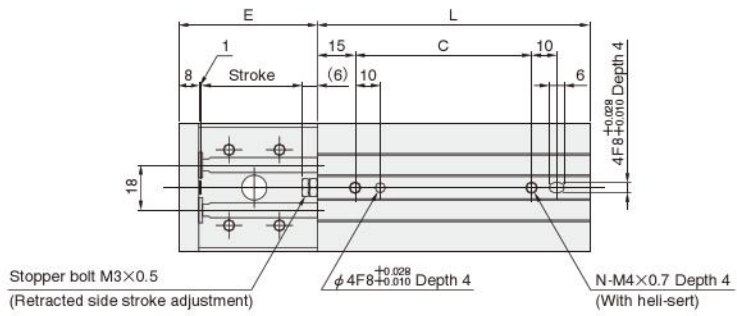
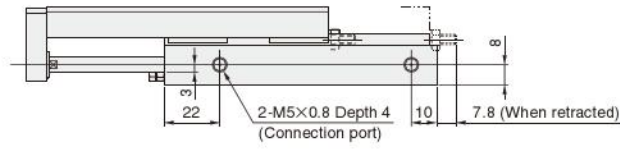
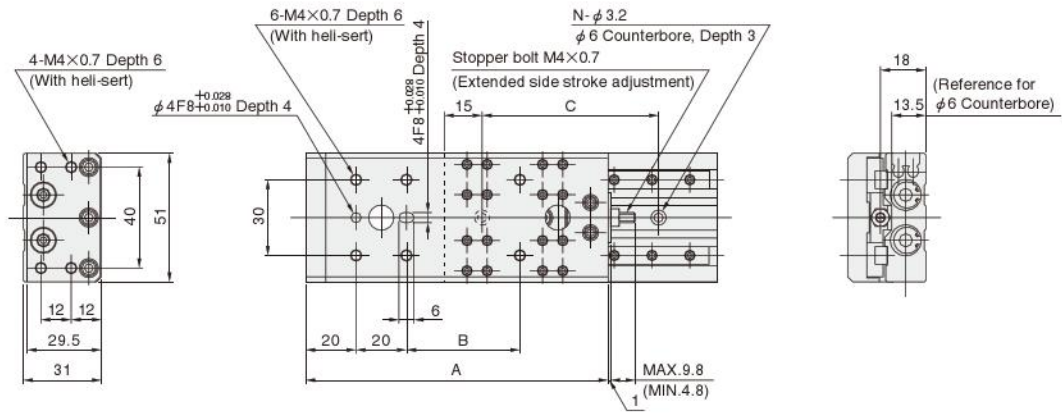

● For 50 and 60mm strokes

Stroke	Code	A	B	C	E	F	L	N
10		90	15	40	25	—	78	2
20		100	25	50	35	—	88	2
30		110	35	60	45	—	98	2
40		120	45	70	55	—	108	2
50		130	55	80	65	40	118	3
60		140	65	90	75	45	128	3

ROD SLIDERS

# Dimensions of Rod Slider Standard Cylinder (mm)

● ARS16 × Stroke

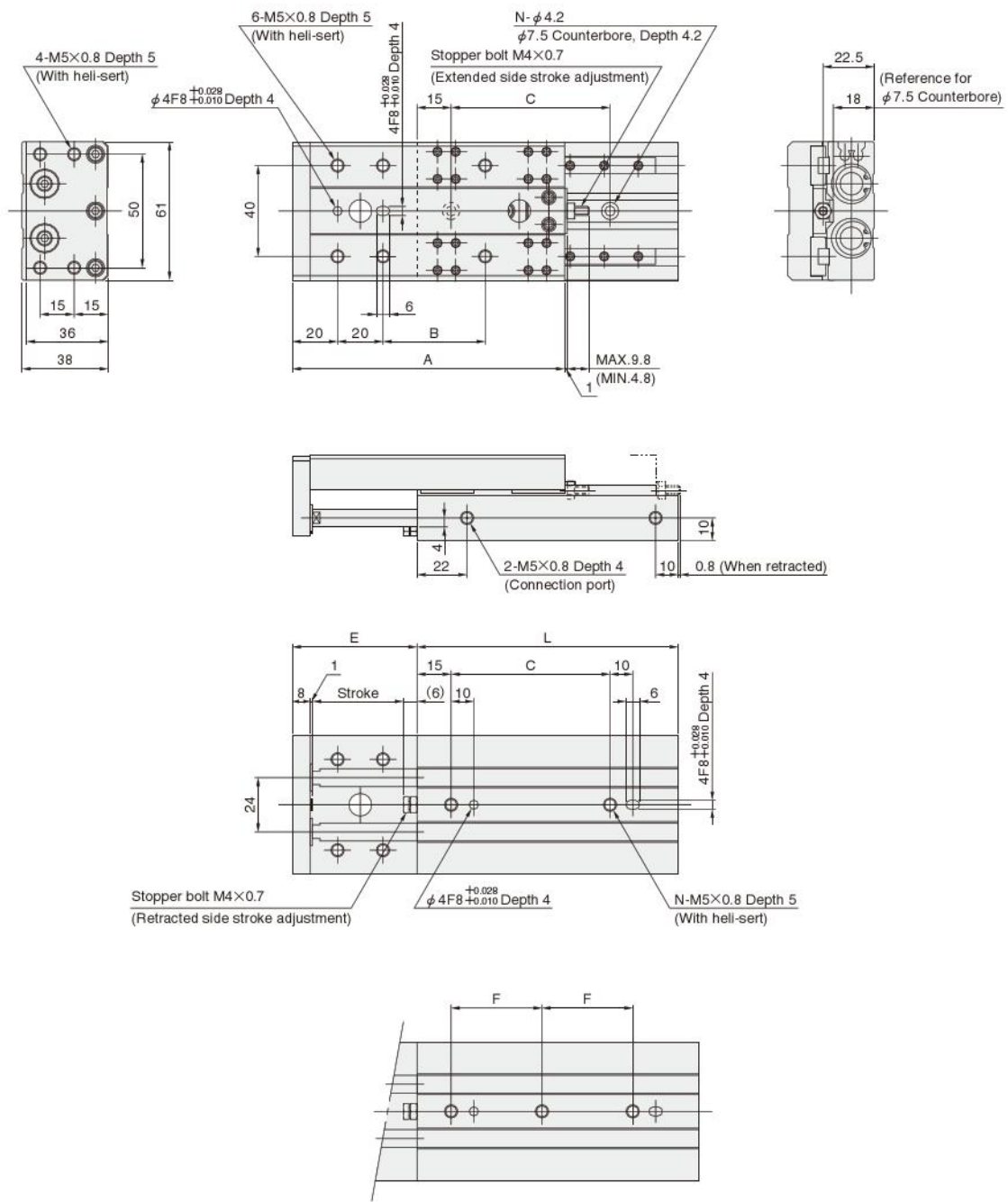

● For 50, 60, and 80mm strokes

Stroke	Code	A	B	C	E	F	L	N
10	90	15	40	25	—	85	2	
20	100	25	50	35	—	95	2	
30	110	35	60	45	—	105	2	
40	120	45	70	55	—	115	2	
50	130	55	80	65	40	125	3	
60	140	65	90	75	45	135	3	
80	160	85	110	95	55	155	3	

# Dimensions of Rod Slider Standard Cylinder (mm)

● ARS20 × Stroke

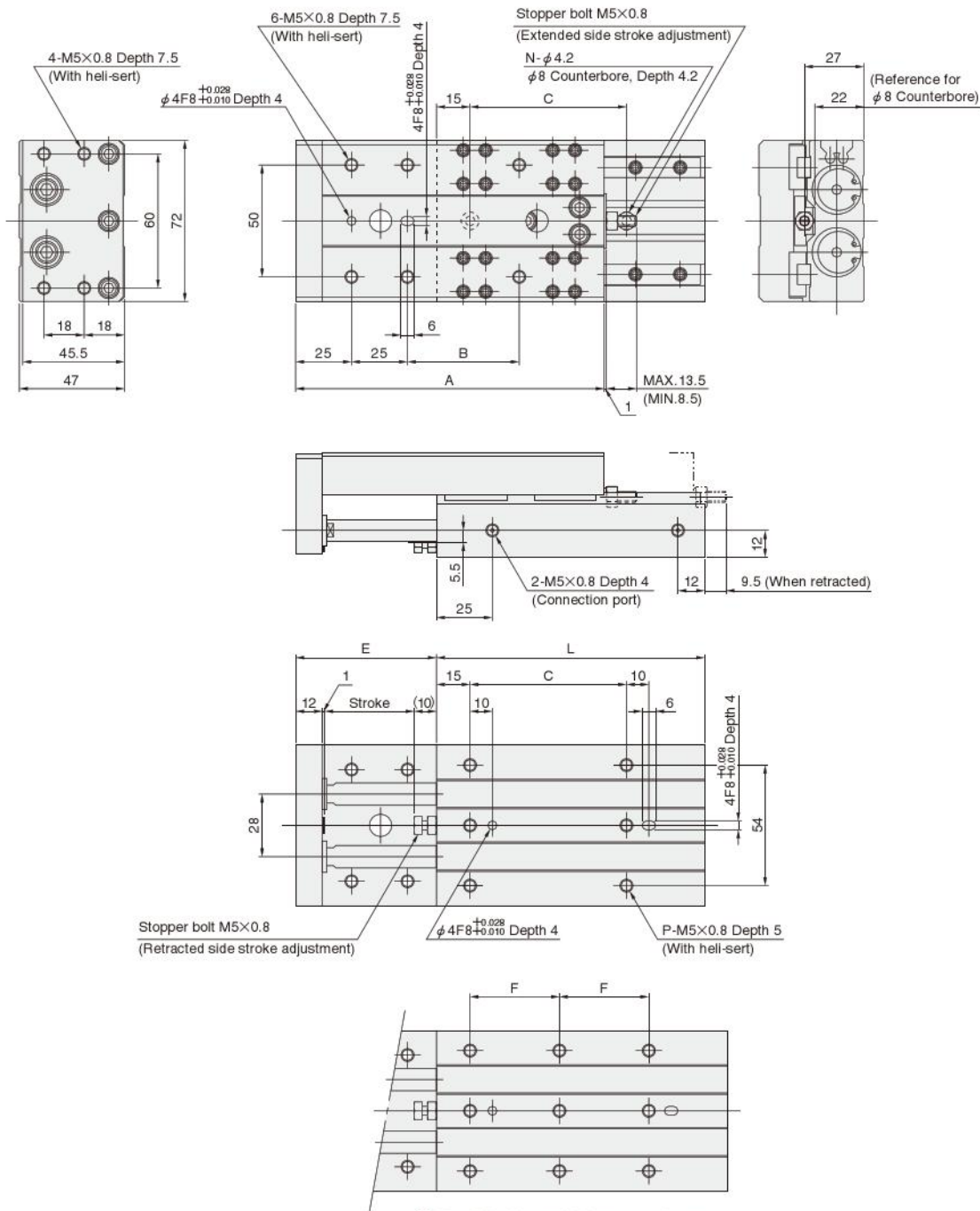

● For 50, 60, and 80mm strokes

Stroke	Code	A	B	C	E	F	L	N	P
10	108	20	40	33	—	90	2	6	
20	118	30	50	43	—	100	2	6	
30	128	40	60	53	—	110	2	6	
40	138	50	70	63	—	120	2	6	
50	148	60	80	73	40	130	3	9	
60	158	70	90	83	45	140	3	9	
80	178	90	110	103	55	160	3	9	

# Dimensions of Rod Slider Standard Cylinder (mm)

● ARS25 × Stroke

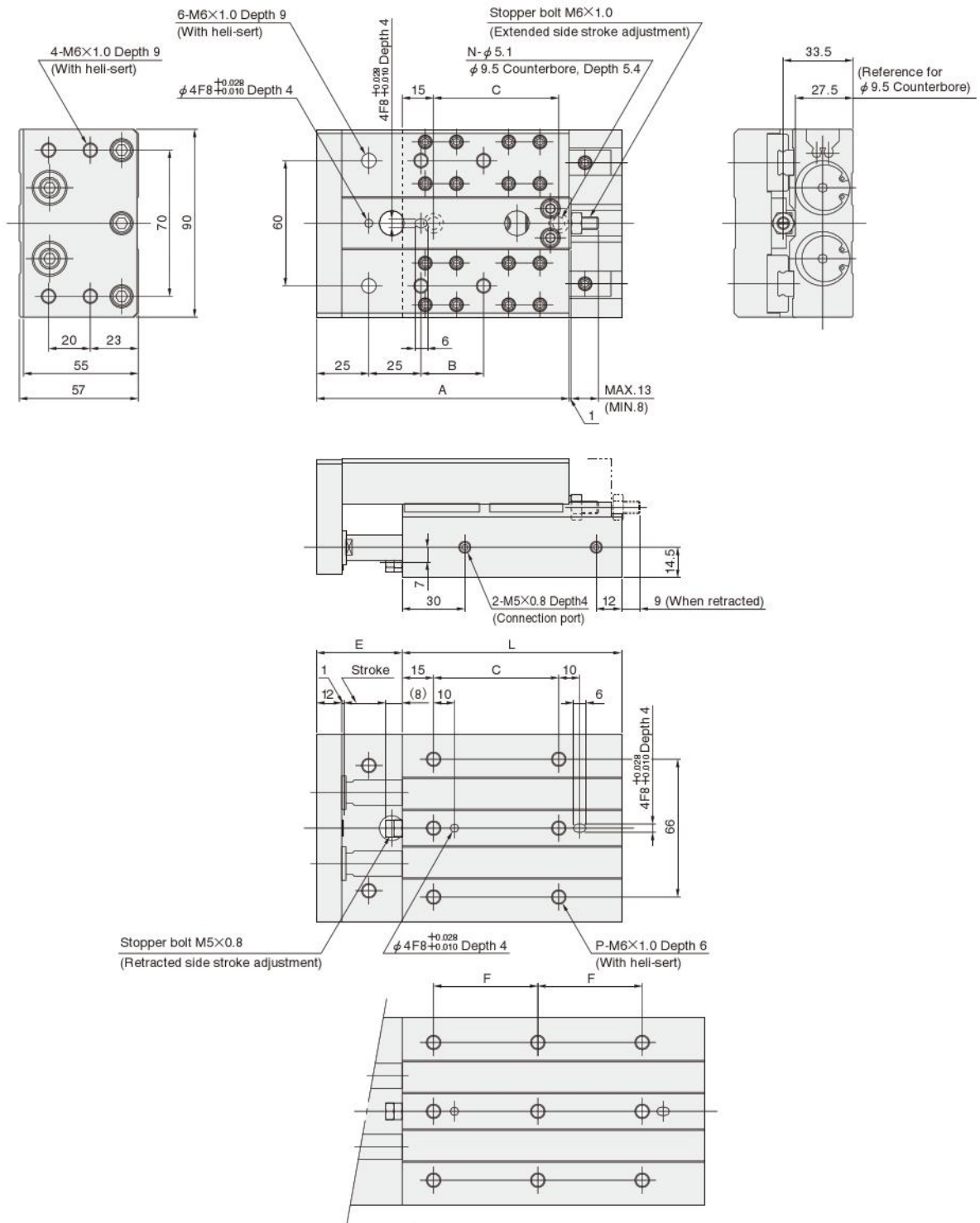

● For 60 and 80mm strokes

Stroke	Code	A	B	C	E	F	L	N	P
10	111	20	50	31	—	95	2	6	
20	121	30	60	41	—	105	2	6	
30	131	40	70	51	—	115	2	6	
40	141	50	80	61	—	125	2	6	
50	151	60	90	71	—	135	2	6	
60	161	70	100	81	50	145	3	9	
80	181	90	120	101	60	165	3	9	

# SENSOR SWITCHES

Solid State Type, Reed Switch Type

## Symbol

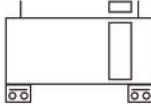

## Order Codes



-ARS

Lead wire length

A : 1000mm [39in.]

B : 3000mm [118in.]

### Sensor switch

**ZE101** : Reed switch type without indicator lamp

**ZE102** : Reed switch type with indicator lamp

**ZE201** : Reed switch type without indicator lamp

**ZE202** : Reed switch type with indicator lamp

**ZE135** : 2-lead wire Solid state type with indicator lamp

**ZE155** : 3-lead wire Solid state type with indicator lamp

**ZE235** : 2-lead wire Solid state type with indicator lamp

**ZE255** : 3-lead wire Solid state type with indicator lamp

Horizontal lead wire

Horizontal lead wire

Vertical lead wire

Vertical lead wire

Horizontal lead wire

Horizontal lead wire

Vertical lead wire

Vertical lead wire

DC5~28V, AC85~115V

DC10~28V, AC85~115V

DC5~28V, AC85~115V

DC10~28V, AC85~115V

DC10~28V

DC4.5~28V

DC10~28V

DC4.5~28V

● For details of sensor switches, see p.1544.

## Mounting Location of End of Stroke Detection Sensor Switch

When the sensor switch is mounted in the locations shown below (the figures in the tables are reference values), the magnet comes to the maximum sensing location of the sensor switch at the end of the stroke.

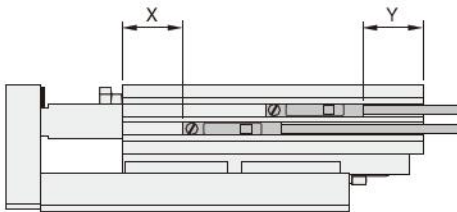

### ● Solid state type

(ZE135, ZE155, ZE235, ZE255)

mm [in.]

Code	Bore	6	10	16	20	25
		[0.236]	[0.394]	[0.630]	[0.787]	[0.984]
<b>X</b>		24 [0.945]	28.5 [1.122]	34 [1.339]	38 [1.496]	45 [1.772]
<b>Y</b>		29 [1.142]	24.5 [0.965]	26 [1.024]	27 [1.063]	25 [0.984]

### ● Reed switch type

(ZE101, ZE102, ZE201, ZE202)

mm [in.]

Code	Bore	6	10	16	20	25
		[0.236]	[0.394]	[0.630]	[0.787]	[0.984]
<b>X</b>		20 [0.787]	24.5 [0.965]	30 [1.181]	34 [1.339]	41 [1.614]
<b>Y</b>		26 [1.024]	21.5 [0.846]	23 [0.906]	24 [0.945]	22 [0.866]

# Sensor Switch Operating Range, Response Differential, and Maximum Sensing Location

## ● Operating range : $\ell$

The distance the piston travels in one direction, while the switch is in the ON position.

## ● Response differential : C

The distance between the point where the piston turns the switch ON and the point where the switch is turned OFF as the piston travels in the opposite direction.

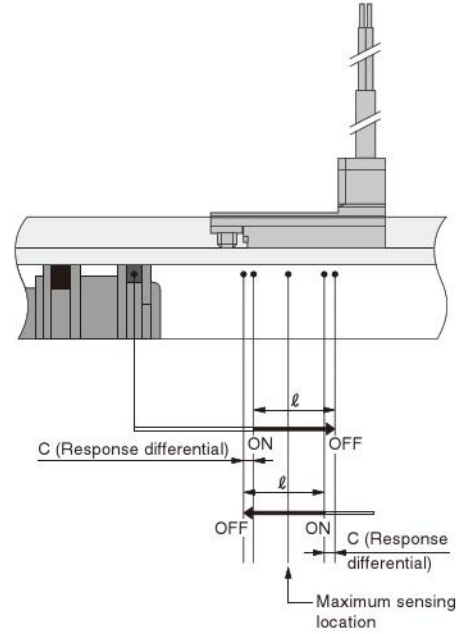

## ● Solid state type

Item \ Bore	6 [0.236]	10 [0.394]	16 [0.630]	20 [0.787]	25 [0.984]
Operating range: $\ell$	2.5~3.5 [0.098~0.138]	2.5~4.0 [0.098~0.157]	2.0~4.5 [0.079~0.177]	2.5~5.5 [0.098~0.217]	
Response differential: C	1.0 [0.039] or less		1.2 [0.047] or less		1.5 [0.059] or less
Maximum sensing location <sup>Note</sup>	6 [0.236]				

Remark: The above table shows reference values.

Note: This is the length measured from the switch's opposite end side to the lead wire.

## ● Reed switch type

Item \ Bore	6 [0.236]	10 [0.394]	16 [0.630]	20 [0.787]	25 [0.984]
Operating range: $\ell$	4.5~7.5 [0.177~0.295]	6.5~8.5 [0.256~0.335]	6.0~8.0 [0.236~0.315]	7.0~9.5 [0.276~0.374]	
Response differential: C	1.5 [0.059] or less				
Maximum sensing location <sup>Note</sup>	10 [0.394]				

Remark: The above table shows reference values.

Note: This is the length measured from the switch's opposite end side to the lead wire.

## When Mounting Rod Sliders with Sensor Switches in Close Proximity

When mounting Rod Sliders with sensor switches in close proximity, install the Rod Sliders so that their mounting dimensions should not be below the values shown in the following tables.

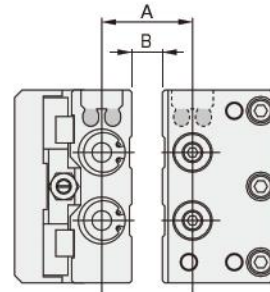
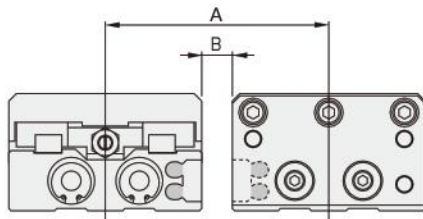

Code	Type	Bore	6 [0.236]	10 [0.394]	16 [0.630]	20 [0.787]	25 [0.984]
A	Solid state type		44 [1.73]	53 [2.09]	66 [2.60]	73 [2.87]	90 [3.54]
	Reed switch type		44 [1.73]	51 [2.01]	61 [2.40]	72 [2.83]	90 [3.54]
B	Solid state type		8 [0.31]	2 [0.08]	5 [0.20]	1 [0.04]	0
	Reed switch type		8 [0.31]	0	0	0	0

Code	Type	Bore	6 [0.236]	10 [0.394]	16 [0.630]	20 [0.787]	25 [0.984]
A	Solid state type		20 [0.79]	24 [0.94]	27 [1.06]	28 [1.10]	33 [1.30]
	Reed switch type		20 [0.79]	20 [0.79]	24 [0.94]	28 [1.10]	33 [1.30]
B	Solid state type		8 [0.31]	8 [0.31]	7 [0.28]	4 [0.16]	4 [0.16]
	Reed switch type		8 [0.31]	4 [0.16]	4 [0.16]	4 [0.16]	4 [0.16]

Remark: For mounting configurations not shown the above, consult us.

## Rod Slider ARS Special Specifications (Excluding ARSZ and ARSK)

For the rod slider **ARS** (standard cylinder), we have prepared the following specifications for certain specials that have proven to be particularly popular.

To order, enter codes in parentheses ( ) at the end of the order code.

As we expand our special product range, we hope you will continue to incorporate new models into your work.

For detailed specifications, dimensions, and delivery schedules, consult us.

### 1. Head side piping specification (-1W)

Available in bore sizes:  $\phi$  6, 10, 16, 20, 25 [0.236, 0.394, 0.630, 0.787, 0.984in.]

The connection port location is changed from the cylinder side to the head side.

※Other specifications are the same as the standard item.

### 2. Reversed piping direction specification (-2W)

Available in bore sizes:  $\phi$  6, 10, 16, 20, 25 [0.236, 0.394, 0.630, 0.787, 0.984in.]

Since **ARS** is restricted in its piping direction, use this specification for placing piping in the reversed direction.

※Other specifications are the same as the standard item.

### 3. Long stroke specification (-5W, -6W)

Available in bore sizes:  $\phi$  6, 10, 16, 20, 25 [0.236, 0.394, 0.630, 0.787, 0.984in.]

Corresponds to the maximum available stroke.

For reference, see the table below.

※Other specifications are the same as the standard item.

Model	Corresponding available strokes
ARS 6 × st - 5W	60, 70
ARS10 × st - 5W	70, 80, 90, 100
ARS16 × st - 5W	70, 90, 100
ARS20 × st - 5W	70, 90, 100
ARS25 × st - 5W	70, 90, 100
ARS16 × st - 6W	110, 120
ARS20 × st - 6W	110, 120, 130, 140, 150
ARS25 × st - 6W	110, 120, 130, 140, 150

mm

### 4. Simplified clean room specification (-8W)

Available in bore sizes:  $\phi$  6, 10, 16, 20, 25 [0.236, 0.394, 0.630, 0.787, 0.984in.]

The grease used on the cylinder and linear guide portion is a low-volatility grease. Moreover, a dust collection port is installed on the rod side of the body. In addition, the linear guide is stainless steel, while the screws are stainless steel or nickel plated, and the items are assembled and double-packaged inside the clean room.

※Other specifications are the same as the standard item.

Order code example: For the head side piping specification

● **ARS10 × 30 - 1W**

Notes: 1. These special specifications may vary from standard items in delivery schedules, prices, dimensions, life cycle, etc. Confirm us the details before ordering.  
2. For the **ARSZ** (cylinder with shock absorber) and **ARSK** (end keep cylinder) special specifications, consult us.