

# AIR-HYDRO CONVERTERS

- No hydraulic unit means no vibration and more precise speed control without pulsation.
- Use compact and lightweight stainless tubes. Optimum for operating Slim Low Hydraulic Cylinders of size  $\phi 20$  to  $\phi 40$ .
- Equipped with oil level marker for easy checking of oil volume.

## Symbol



## Specifications

Item	Model	AHC□×□
Maximum operating pressure	MPa [psi.]	0.9 [131]
Proof pressure	MPa [psi.]	1.3 [189]
Operating temperature range	°C [°F]	5~60 [41~140]

## Order Codes

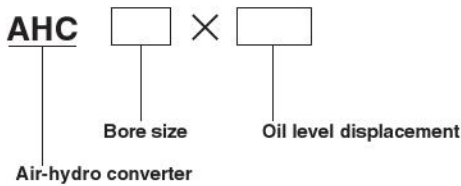

## Bore size and Oil Level Displacement

Bore size	Standard oil level displacement				Maximum oil level displacement	Maximum available oil level displacement
	50	100	200	300		
32	50	100	200		300	750
40	50	100	200		400	
50	50	100	200	300	500	

## Mass

Bore size mm	Oil level displacement mm				Additional mass for each additional 1mm [0.04in.] over the standard oil level displacement
	50	100	200	300	
32	0.280 [0.617]	0.313 [0.690]	0.378 [0.833]	(0.443) ([0.977])	0.00065 [0.023oz.]
40	0.405 [0.893]	0.446 [0.983]	0.527 [1.162]	(0.608) ([1.340])	0.00081 [0.029oz.]
50	0.655 [1.444]	0.719 [1.585]	0.846 [1.865]	0.937 [2.066]	0.00127 [0.045oz.]

## Recommended Hydraulic Oil

For the hydraulic oil, use a petroleum-based hydraulic oil, or turbine oil with antifoaming additive. (ISO VG22~100 equivalent)  
Avoid using incombustible hydraulic oil, spindle oil, or machine oil.

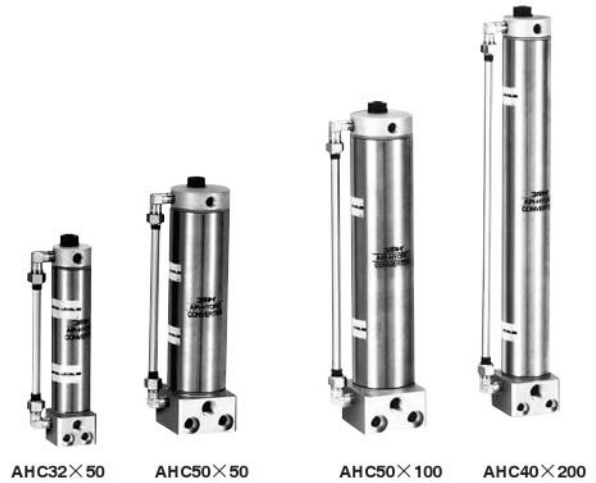

## Inner Construction and Major Parts

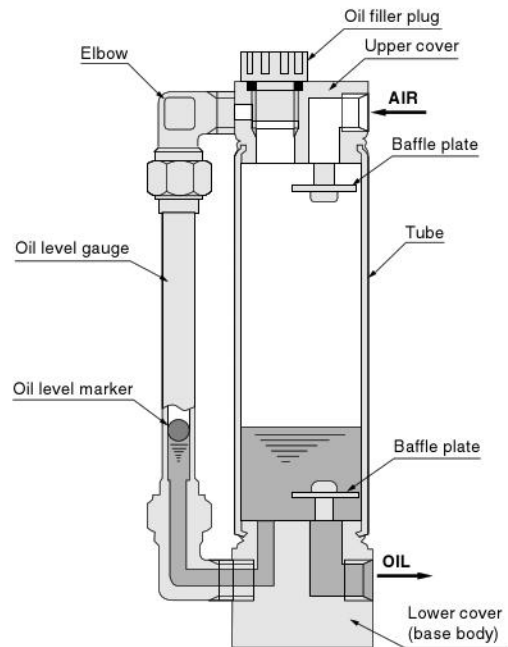

## Major Parts and Materials

Parts	Materials
Tube	Stainless steel
Upper cover	Aluminum alloy
Lower cover	
Baffle plate	Mild steel
Oil level gauge	Hard nylon tube
Oil filler plug	Plastic
Elbow	Brass (nickel plated)

## Selection Guideline

### ● Precautions for selection

- When using the converter, restrict the cylinder load ratio to 50% or less. In addition, use a hydraulic line connected on both cylinder ports to prevent intrusion of air.
- Select a converter bore that is one size larger than the cylinder bore. This will reduce roiling during fluid level movement, as well as reduce the intrusion of air bubbles.
- The converter's oil volume should be 50% greater than the cylinder's volume.
- Select a converter that will keep the rate of oil level rise as slow as possible. The maximum allowed speed of oil level rise is 200mm/s. Exceeding this rate could result in oil spraying out.

### ● Selection procedure

- First, check the cylinder bore and speed to determine the converter bore. The converter's maximum allowed rate of oil level rise is 200mm/s. (Graph 1)
- Next, use the cylinder bore and stroke to determine the converter's oil level displacement. (Graph 2)

**Graph 1: Quick check for oil level increase rate in converter**

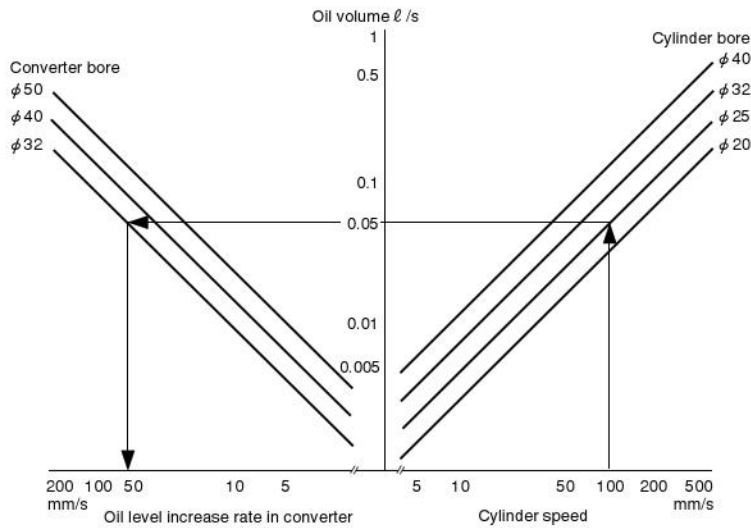

1  $\ell / \text{min} = 0.0353 \text{ft}^3/\text{min}$ .  
 1mm/s = 0.0394in./sec.

Example: With a cylinder bore size of 25 mm and a speed of 100 mm/s, selection of a converter with bore of 32mm will result in an oil level increase rate of about 60mm/s.

**Graph 2: Quick check for converter oil level displacement**

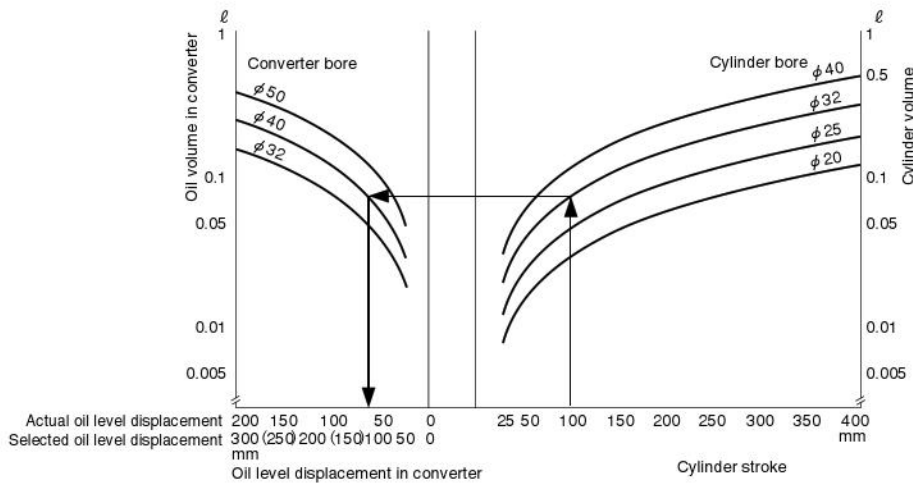

Example: With a cylinder bore size of 32mm and a stroke of 100mm, selection of a converter bore of 40mm will result in actual oil level displacement of about 65mm. In this case, select a converter with oil level displacement of 100mm.

## ● Cylinder volume

ℓ [ft.<sup>3</sup>]

Cylinder bore mm [in.]	Stroke mm [in.]										
	25 [0.98]	50 [1.97]	75 [2.95]	100 [3.94]	125 [4.92]	150 [5.91]	200 [7.87]	250 [9.84]	300 [11.8]	350 [13.8]	400 [15.7]
<b>20 [0.79]</b>	0.0079 [0.00028]	0.0157 [0.00055]	0.0236 [0.00083]	0.0314 [0.00111]	0.0393 [0.00139]	0.0471 [0.00166]	(0.0628) ([0.00222])	(0.0785) ([0.00277])	(0.0942) ([0.00333])	(0.1099) ([0.00388])	(0.1256) ([0.00443])
<b>25 [0.98]</b>	0.0123 [0.00043]	0.0245 [0.00086]	0.0368 [0.00130]	0.049 [0.00173]	0.0613 [0.00216]	0.0735 [0.00259]	0.098 [0.00346]	(0.1225) ([0.00432])	(0.147) ([0.00519])	(0.1715) ([0.00605])	(0.196) ([0.00692])
<b>32 [1.26]</b>	0.0201 [0.00071]	0.0402 [0.00142]	0.0602 [0.00213]	0.0803 [0.00283]	0.1004 [0.00354]	0.1206 [0.00426]	0.1608 [0.00568]	(0.2008) ([0.00709])	(0.2409) ([0.00850])	(0.2811) ([0.00992])	(0.3212) ([0.01134])
<b>40 [1.57]</b>	0.0314 [0.00111]	0.0628 [0.00222]	0.0942 [0.00333]	0.1256 [0.00443]	0.157 [0.00554]	0.1884 [0.00665]	0.2512 [0.00887]	0.314 [0.01108]	0.3768 [0.01330]	(0.4396) ([0.01552])	(0.5024) ([0.01773])

Note: Figures in parentheses ( ) show cylinder volume for non-standard strokes.

## ● Air-hydro converter volume

ℓ [ft.<sup>3</sup>]

Converter bore mm [in.]	Oil level displacement mm [in.]						
	50 [1.97]	100 [3.94]	(150 [5.91])	200 [7.87]	(250 [9.84])	300 [11.8]	400 [15.7]
<b>32 [1.26]</b>	0.0402 [0.00142]	0.0803 [0.00283]	(0.1205) ([0.00425])	0.1606 [0.00567]	(0.2008) ([0.00709])	(0.2409) ([0.00850])	(0.3212) ([0.01134])
<b>40 [1.57]</b>	0.0628 [0.00222]	0.1256 [0.00443]	(0.1884) ([0.00665])	0.2512 [0.00887]	(0.314) ([0.01108])	(0.3768) ([0.01330])	(0.5024) ([0.01773])
<b>50 [1.97]</b>	0.0982 [0.00347]	0.1963 [0.00693]	(0.2945) ([0.01040])	0.3926 [0.01386]	(0.4908) ([0.01733])	0.5889 [0.02079]	(0.7852) ([0.02772])

Note: Figures in parentheses ( ) show made to order products.

## Dimensions (mm)

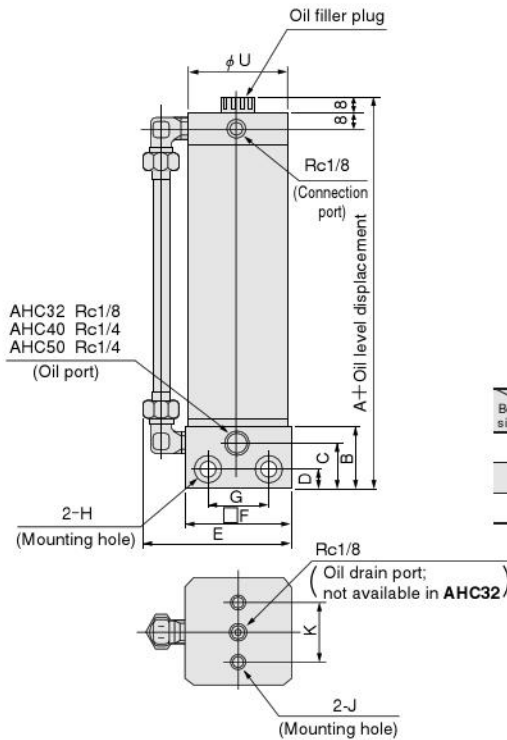

Bore size	Code	A	B	C	D	E	F	G	H	J	K	U
		<b>32</b>	117	26	18	7	59	35	16	φ 6.6 Counterbore φ 11 Depth6	M6 X1 Depth6	14
<b>40</b>	149	29	19.5	7	67	45	26	φ 6.6 Counterbore φ 11 Depth6	M6 X1 Depth6	26	41.6	
<b>50</b>	156	32	22.5	9	71	55	32	φ 9 Counterbore φ 14 Depth8	M8 X1.25 Depth9	30	52	

# Handling Instructions and Precautions

## ● Oil filling procedure

### ● If converter is at a higher position than cylinder

1. Move the cylinder piston to the stroke end in the oil supply side, and supply oil until it reaches the top of the oil level gauge. ( a , b )  
If an air bleeder is installed, supply oil while pressing down the air bleeder button until all air has escaped.
2. Open the speed controller all the way, and operate the cylinder without load for about 100 operation cycles ( c ). If oil appears to be needed, use the procedure in 1 above to supply oil until it reaches the top of the oil level gauge. ( d , e )

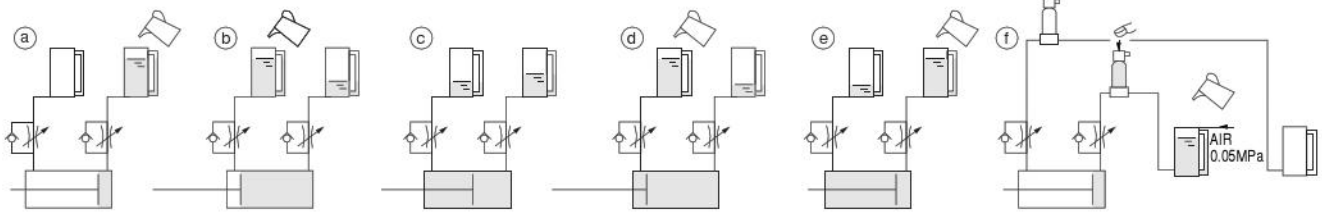

※Mount the air bleeder to the highest position in piping.

## ● Precautions

- Mount the converter in a vertical position. In addition, installing in a position higher than the cylinder will ease air bleed and oil supply operations.
- For piping, use fittings and tubes with reasonably similar bore sizes. This will limit the occurrence of air bubbles.
- For piping operations, always flush out the piping to remove any foreign material. In addition, anaerobic liquid sealant is recommended for sealing

### ● If converter is at a lower position than cylinder

(Because of the difficulty in performing air bleed operations, avoid this mounting position as much as possible.)

1. Move the cylinder piston to the stroke end in the oil supply side, supply oil until it reaches the top of the oil level gauge, and screw and seal the oil filler plug. Then apply 0.05MPa [7psi.] of air pressure via the converter's air port, and repeatedly press down on the air bleeder's button until all air has escaped. ( f )
2. Open the speed controller all the way, and operate the cylinder without load for about 100 operation cycles. If oil appears to be needed, use the procedure in 1 above to supply oil until it reaches the top of the oil level gauge.

- the fittings. Avoid the use of sealing tape if at all possible, since it could cause clogging.
- After piping operations, apply air pressure to the system to check for leaks before supplying oil.
- For the oil supplied to the converter, always use the recommended hydraulic oil.