

More precision



We have added advanced positioning precision and high rigidity to the pneumatic actuator.

The Koganei Alpha Series further enhances the drive module concept, supporting superior applications and labor savings in FA line design and manufacturing with higher performance.

GT SLIDE TABLES (B and C TYPES)

The Alpha Series GT slide table combines a cylinder and miniature guide in a compact body for a unit-type compact actuator developed for advanced precision and high rigidity in the Z-axis component.

Piping space has been greatly reduced.

The design saves on piping and wiring connections by concentrating all piping ports and wiring outlets on a single plane. Allows streamlined, compact mechanical devices.



Stopper bolt is standard equipment to facilitate fine adjustment at the end of the stroke.

The stopper bolt, which enables fine stroke adjustment ($-9\sim 0\text{mm}$ [$-0.354\sim 0\text{in.}$] at one end) in addition to excellent repeatability at the end of the stroke ($\pm 0.025\text{mm}$ [$\pm 0.001\text{in.}$]), is standard equipment. It reduces labor hours for mounting and adjustment.



Use miniature guides to maintain precision.

It is the industry's first compact slide table to use a circulating-type miniature guide. A highly reliable ball bearing mechanism eliminates friction with the guide rail, responds to large bending moment, and maintains precision over long periods.

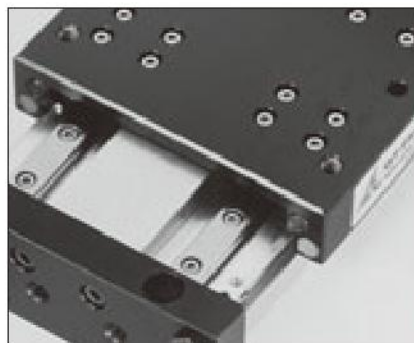

Instantly and easily respond to more accurate actuator controls.

Because a built-in magnet for sensor switch is standard, mounting a sensor switch is all that is needed to ensure detection of the end of the stroke. Advanced $\square 4\text{mm}$ [0.157in.] compact sensor switches (4 types) can be mounted without protruding from the body.



Model	Type	Indicator lamp	Voltage
ZC330□	Solid state type	Available	DC10~28V
ZC353□	Solid state type	Available	DC4.5~28V
ZC301□	Reed switch type	Not available	AC85~115V DC5~28V
ZC305□	Reed switch type	Available	DC10~28V

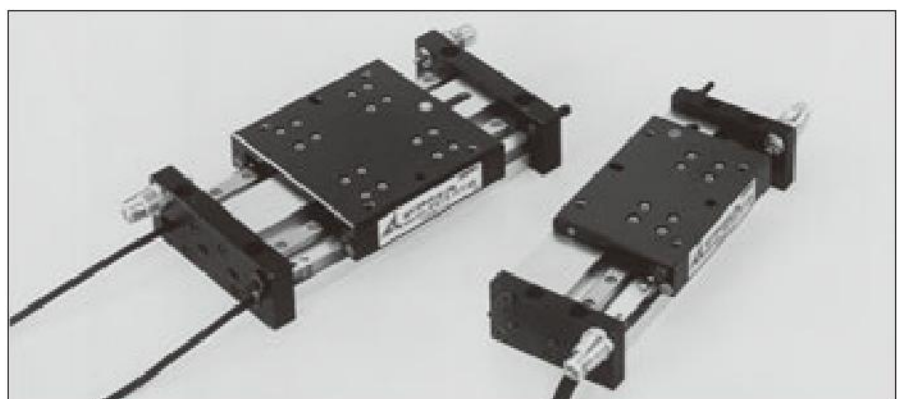

Thinner than ever AGTB

Stopper bolt makes fine adjustment at the end of the stroke easy.

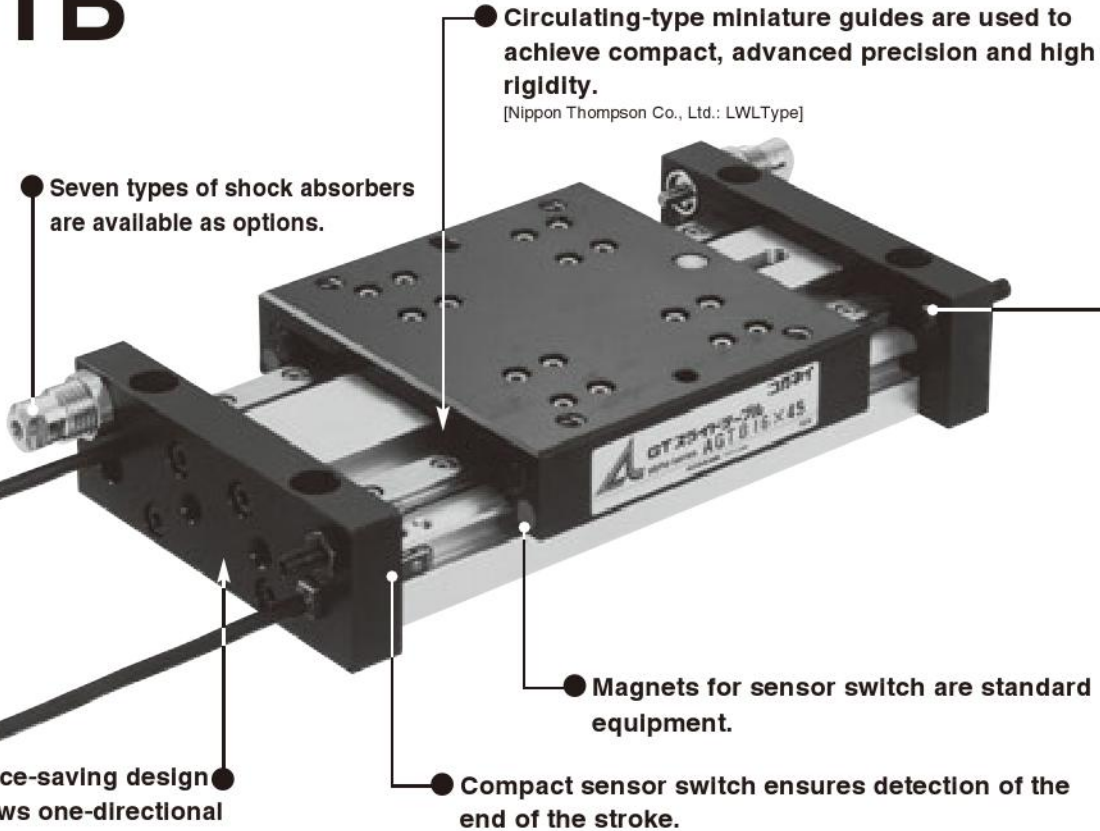

GT SLIDE TABLES (B AND C TYPES)

Lighter than ever AGTC



GT SLIDE TABLES

Specifications

Item		Model	AGTB10	AGTB16	AGTB25	AGTC10	AGTC16	
Bore size		mm [in.]	10 [0.394]	16 [0.630]	25 [0.984]	10 [0.394]	16 [0.630]	
Operation type			Double acting type					
Media			Air					
Operating pressure range		MPa [psi.]	0.16~0.7 [23~102]	0.12~0.7 [17~102]	0.10~0.7 [15~102]	0.16~0.7 [23~102]	0.12~0.7 [17~102]	
Proof pressure		MPa [psi.]	1.03 [149]					
Operating temperature range		°C [°F]	0~60 [32~140]					
Operating speed range		mm/s [in./sec.]	100~300 [3.9~11.8] (With shock absorber: 100~500 [3.9~19.7])					
Cushion			Shock absorber (Optional)					
Lubrication		Cylinder portion	Not required (If lubrication is required, use Turbine Oil Class 1 [ISO VG32] or equivalent.)					
		Guide portion	Required (Lithium soap-based grease) ^{Note}					
Repeatability		mm [in.]	±0.025 [±0.001]					
Traveling parallelism		mm [in.]	0.08 [0.0031]					
Stroke adjusting range		mm [in.]	-16~0 [-0.630~0]	-12~0 [-0.472~0]	-20~0 [-0.787~0]	-16~0 [-0.630~0]		
Maximum load capacity N [lbf.]		With shock absorber	Horizontal mount (W1)	29.4 [6.6]	39.2 [8.8]	49.0 [11.0]	14.7 [3.3]	19.6 [4.4]
			Except horizontal mount (W2, W3, W4)	29.4 [6.6]	39.2 [8.8]	39.2 [8.8]	14.7 [3.3]	19.6 [4.4]
		No shock absorber	Horizontal mount (W1)	14.7 [3.3]	19.6 [4.4]	29.4 [6.6]	4.9 [1.1]	9.8 [2.2]
			Except horizontal mount (W2, W3, W4)	14.7 [3.3]	19.6 [4.4]	29.4 [6.6]	4.9 [1.1]	9.8 [2.2]
Port size			M5×0.8					

Note: Apply grease on the raceway surface of the track rail every 6 months or every 300km [186mi.] of traveling distance.

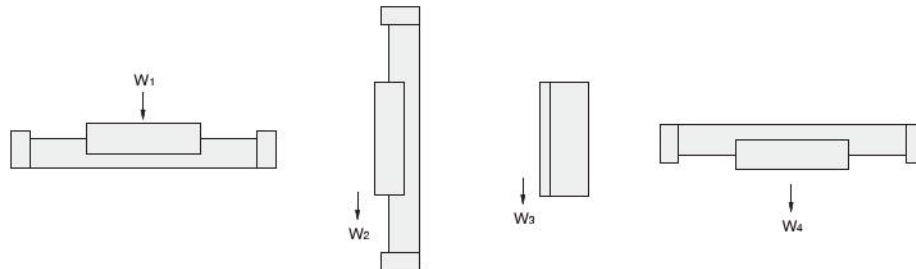

Shock Absorber Specifications

Item	Model	KSHA6×5-A	KSHA6×5-B	KSHA6×5-D	KSHA6×5-DE	KSHA6×8-D	KSHA6×8-E	KSHA6×8-F
Maximum absorption J [ft·lbf]		0.1 [0.07]	0.29 [0.21]	0.98 [0.72]	1.47 [1.08]	0.98 [0.72]	1.96 [1.45]	2.94 [2.17]
Absorbing stroke mm [in.]		5 [0.197]				8 [0.315]		
Maximum impact speed mm/s [in./sec.]		1000 [39.4]						
Maximum operating frequency cycle/min		60				30		
Spring return force ^{Note} N [lbf]		4.02 [0.90]				6.47 [1.45]		
Angle variation		1° or less				3° or less		
Operating temperature range °C [°F]		0~60 [32~140]						

Note: The value obtained at the retracted position.

Remarks: 1. For shock absorbers, see the General Catalog of Air Treatment, Auxiliary, Vacuum or technical documents.

2. Tighten the shock absorber mounting nuts with a tightening torque of 637N·cm [56.4in·lbf].

Bore Size and Stroke

● AGTB mm	
Bore size	Standard strokes
10	15, 30, 45, 60, 75, 90, 105, 120
16	
25	

● AGTC mm	
Bore size	Standard strokes
10	15, 30, 45, 60, 75, 90, 105, 120
16	

Mass

● AGTB g [oz.]								
Bore size mm [in.] \ Stroke mm	15	30	45	60	75	90	105	120
10 [0.394]	320 [11.29]	350 [12.35]	420 [14.81]	490 [17.28]	570 [20.11]	640 [22.57]	720 [25.40]	790 [27.87]
16 [0.630]	440 [15.52]	480 [16.93]	580 [20.46]	680 [23.99]	790 [27.87]	890 [31.39]	1000 [35.27]	1100 [38.80]
25 [0.984]	670 [23.63]	730 [25.75]	880 [31.04]	1030 [36.33]	1190 [41.98]	1340 [47.27]	1500 [52.91]	1650 [58.20]

● AGTC g [oz.]								
Bore size mm [in.] \ Stroke mm	15	30	45	60	75	90	105	120
10 [0.394]	230 [8.11]	250 [8.82]	300 [10.58]	350 [12.35]	410 [14.46]	460 [16.23]	510 [17.99]	560 [19.75]
16 [0.630]	280 [9.88]	310 [10.93]	380 [13.40]	440 [15.52]	520 [18.34]	580 [20.46]	650 [22.93]	720 [25.40]

Additional mass of options

Shock absorber (for 2 pcs.) g [oz.]

Model	Mass
KSHA6×5-□	20 [0.71]
KSHA6×8-□	40 [1.41]

Sensor switch (for 1 pc.) g [oz.]

Model	Mass ^{Note}
ZC330	20 [0.71]
ZC353	20 [0.71]
ZC301	20 [0.71]
ZC305	20 [0.71]

Note: For a lead wire length of 1000mm [39in.]

Remark: Tighten the mounting screw for sensor switch with a tightening torque of 19.6N·cm [1.7in·lbf].

Order Codes

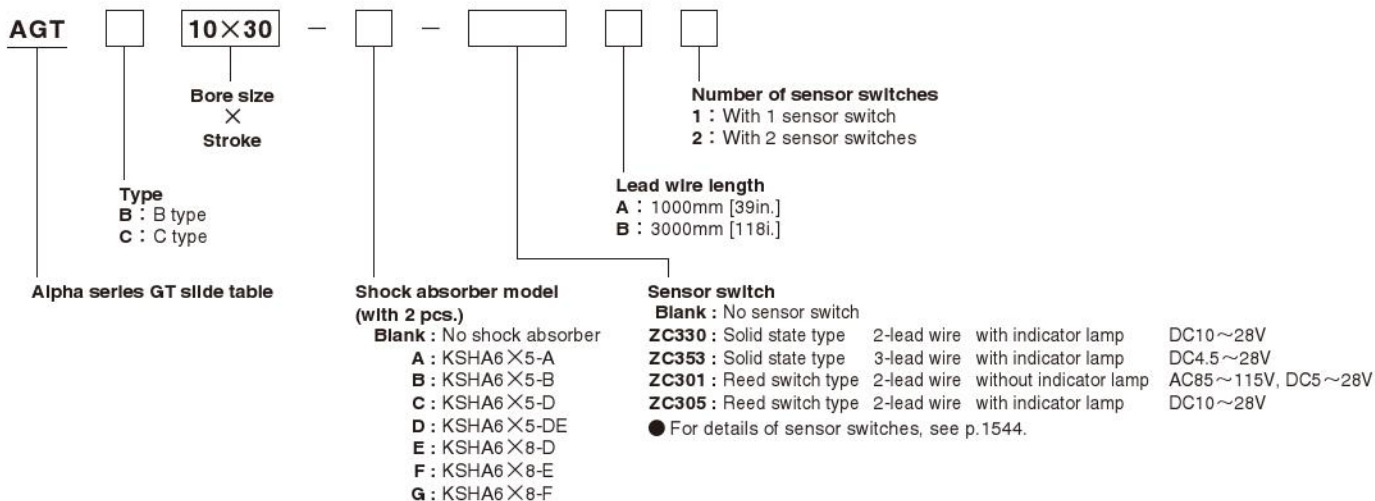

Order code for sensor switches only (with mounting screw, and they can be used for both AGTB and AGTC)

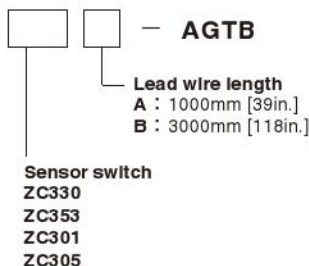

※ When just the mounting screw for sensor switch is required, consult us.
Order code : Y093139

Allowable Moment and Displacement

● Allowable moment

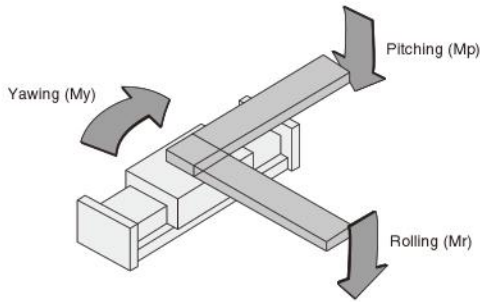

Pitching and yawing

● **AGTB** N · m [ft · lbf]

Bore size mm [in.]	Stroke mm							
	15	30	45	60	75	90	105	120
10 [0.394]								
16 [0.630]	5.0 [3.67]	5.0 [3.67]	7.0 [5.14]	7.0 [5.14]	10.0 [7.35]	10.0 [7.35]	15.0 [11.06]	15.0 [11.06]
25 [0.984]								

● **AGTC** N · m [ft · lbf]

Bore size mm [in.]	Stroke mm							
	15	30	45	60	75	90	105	120
10 [0.394]	2.5 [1.84]	2.5 [1.84]	3.5 [2.57]	3.5 [2.57]	5.0 [3.67]	5.0 [3.67]	8.0 [5.88]	8.0 [5.88]
16 [0.630]								

Rolling

● **AGTB** N · m [ft · lbf]

Bore size mm [in.]	Stroke mm	Allowable Moment
10 [0.394]	15~120	7.0 [5.16]
		8.0 [5.90]
		10.0 [7.38]

● **AGTC** N · m [ft · lbf]

Bore size mm [in.]	Stroke mm	Allowable Moment
10 [0.394]	15~120	1.0 [0.74]

● Table end displacement when applying allowable moment (reference value)

● AGTB

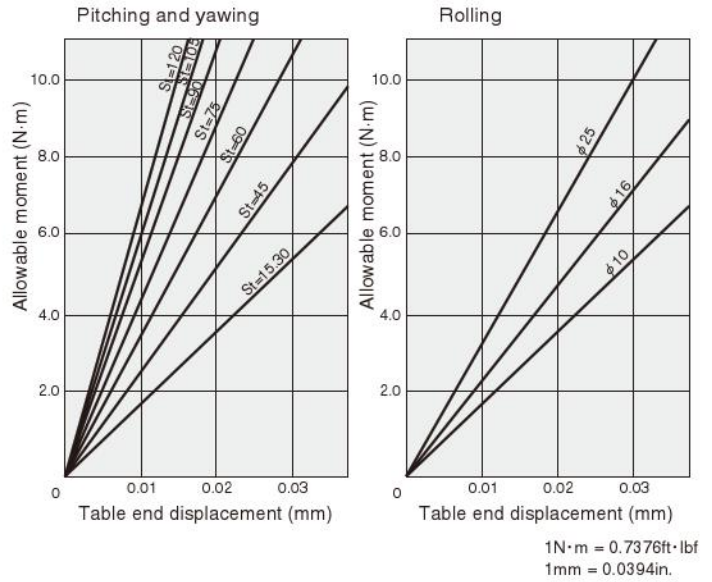

● AGTC

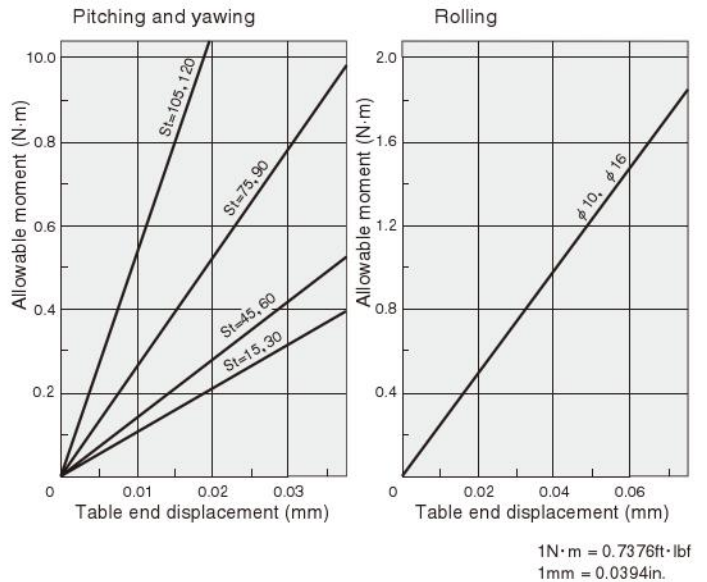

● $\phi 10$ [0.394in.] ● Maximum load capacity 29.4N [6.6lbf.] (With shock absorbers)

● Drawings show specification strokes.

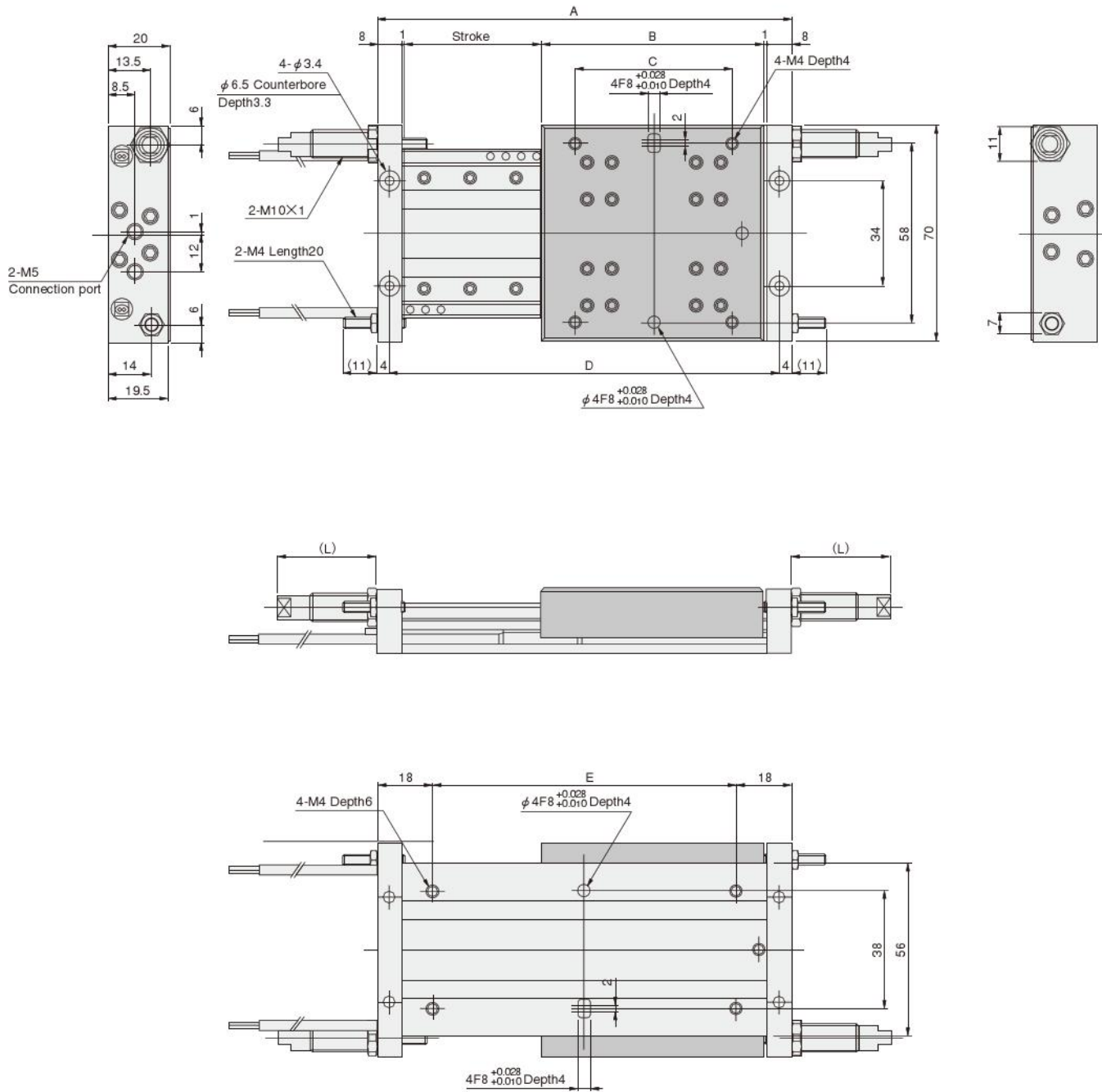

GT SLIDE TABLES (B AND C TYPES)

Stroke	Code	A	B	C	D	E
15		91	58	35	83	55
30		106	58	35	98	70
45		136	73	50	128	100
60		166	88	65	158	130
75		196	103	80	188	160
90		226	118	95	218	190
105		256	133	110	248	220
120		286	148	125	278	250

Shock Absorber L Dimension Table

Model	L dimension	MIN.	MAX.
-A(KSHA6×5-A)		9.5	17.5
-B(KSHA6×5-B)		9.5	17.5
-C(KSHA6×5-D)		9.5	17.5
-D(KSHA6×5-DE)		9.5	17.5
-E(KSHA6×8-D)		24	32
-F(KSHA6×8-E)		24	32
-G(KSHA6×8-F)		24	32

● $\phi 16$ [0.630in.] ● Maximum load capacity 39.2N [8.8lbf.] (With shock absorbers)

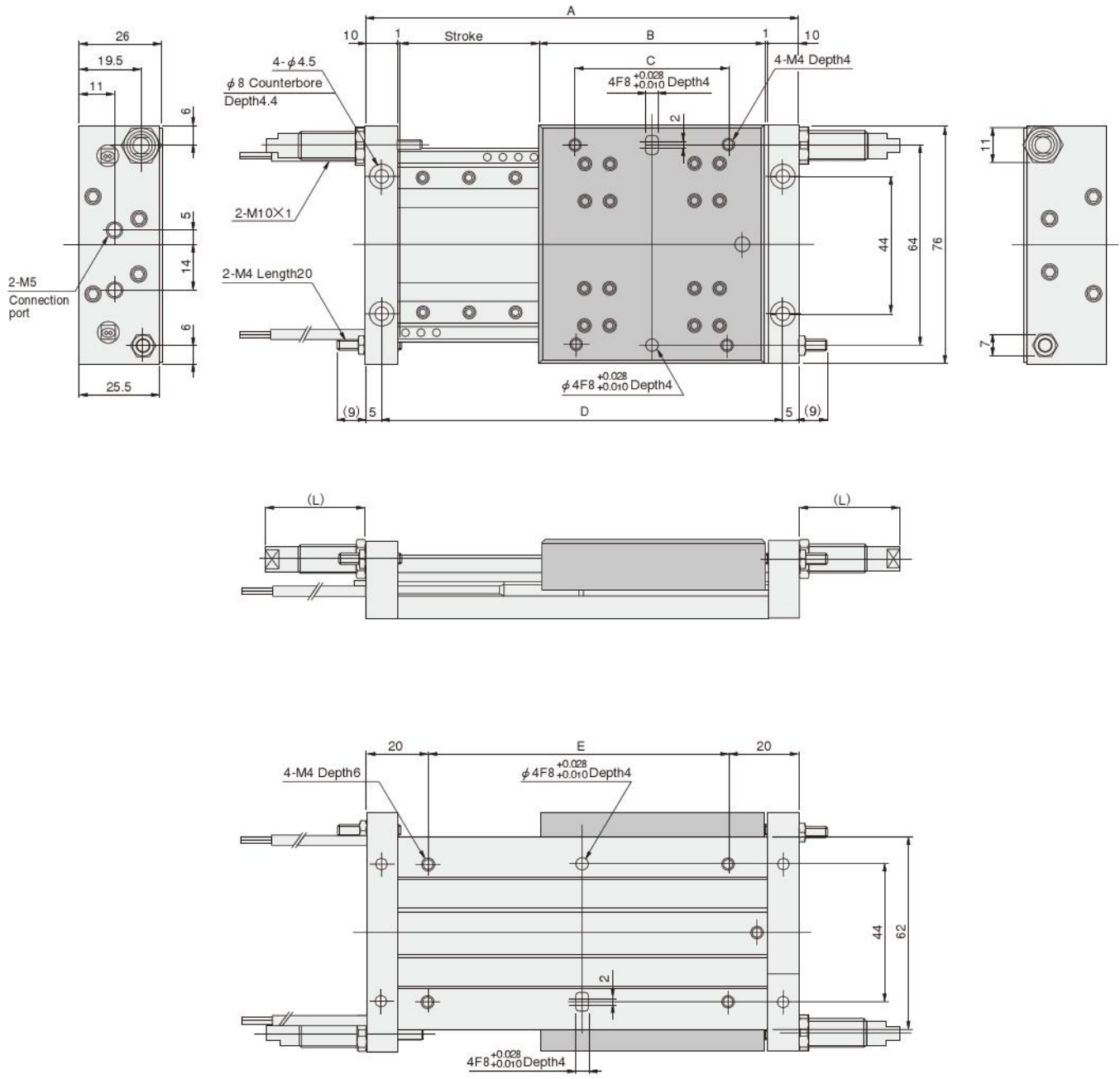

Shock Absorber L Dimension Table

Stroke	Code	A	B	C	D	E
15		95	58	35	85	55
30		110	58	35	100	70
45		140	73	50	130	100
60		170	88	65	160	130
75		200	103	80	190	160
90		230	118	95	220	190
105		260	133	110	250	220
120		290	148	125	280	250

Model	L dimension	MIN.	MAX.
-A(KSHA6 X5-A)		9.5	15.5
-B(KSHA6 X5-B)		9.5	15.5
-C(KSHA6 X5-D)		9.5	15.5
-D(KSHA6 X5-DE)		9.5	15.5
-E(KSHA6 X8-D)		24	30
-F(KSHA6 X8-E)		24	30
-G(KSHA6 X8-F)		24	30

● $\phi 25$ [0.984in.] ● Maximum load capacity 49.0N [11.0lbf.] (With shock absorbers)

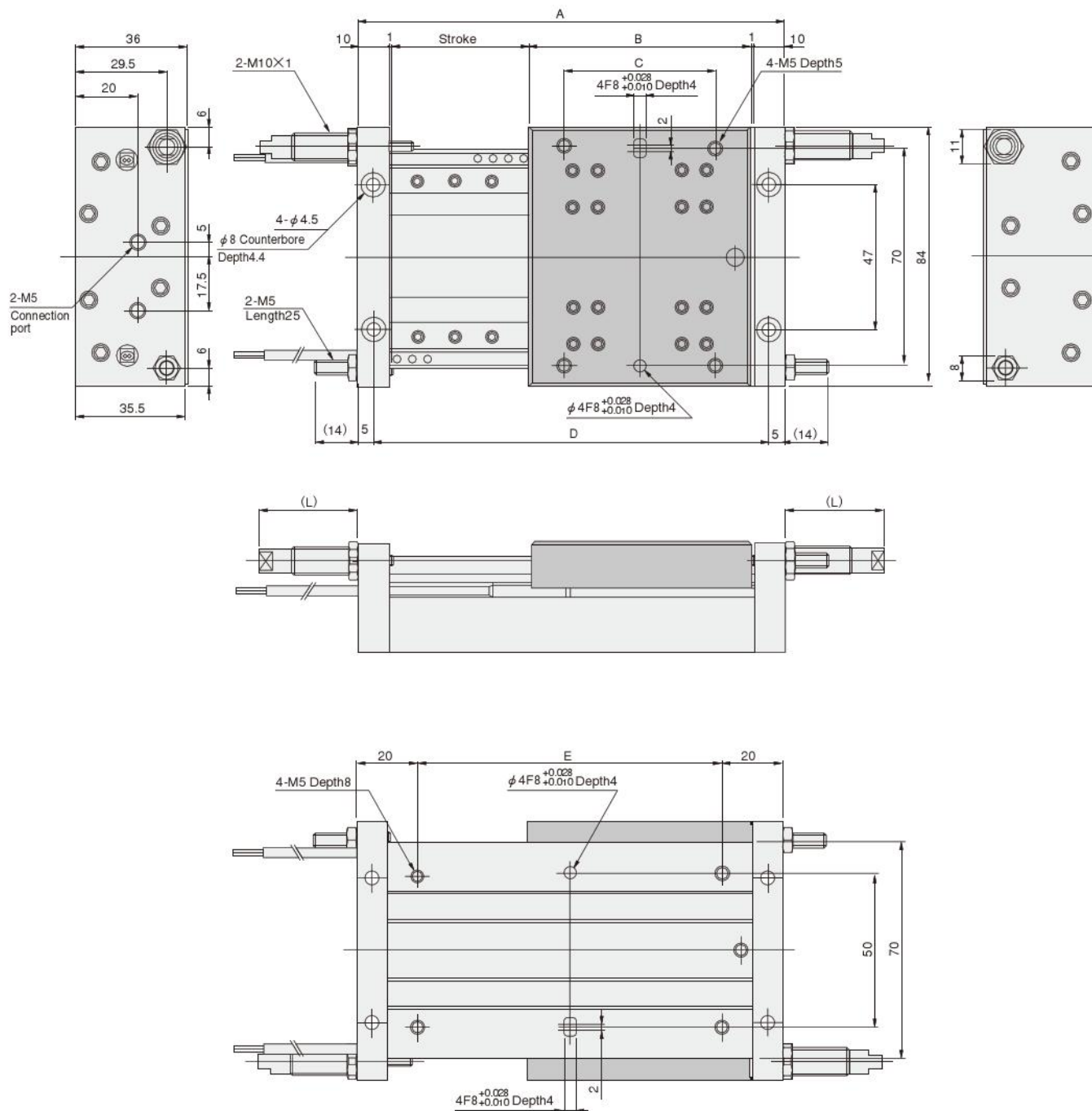

GT SLIDE TABLES (B AND C TYPES)

Stroke	Code	A	B	C	D	E
15		95	58	35	85	55
30		110	58	35	100	70
45		140	73	50	130	100
60		170	88	65	160	130
75		200	103	80	190	160
90		230	118	95	220	190
105		260	133	110	250	220
120		290	148	125	280	250

Shock Absorber L Dimension Table

Model	L dimension	MIN.	MAX.
-A(KSHA6×5-A)		5.5	15.5
-B(KSHA6×5-B)		5.5	15.5
-C(KSHA6×5-D)		5.5	15.5
-D(KSHA6×5-DE)		5.5	15.5
-E(KSHA6×8-D)		20	30
-F(KSHA6×8-E)		20	30
-G(KSHA6×8-F)		20	30

● $\phi 10$ [0.394in.] ● Maximum load capacity 14.7N [3.3lbf.] (With shock absorbers)

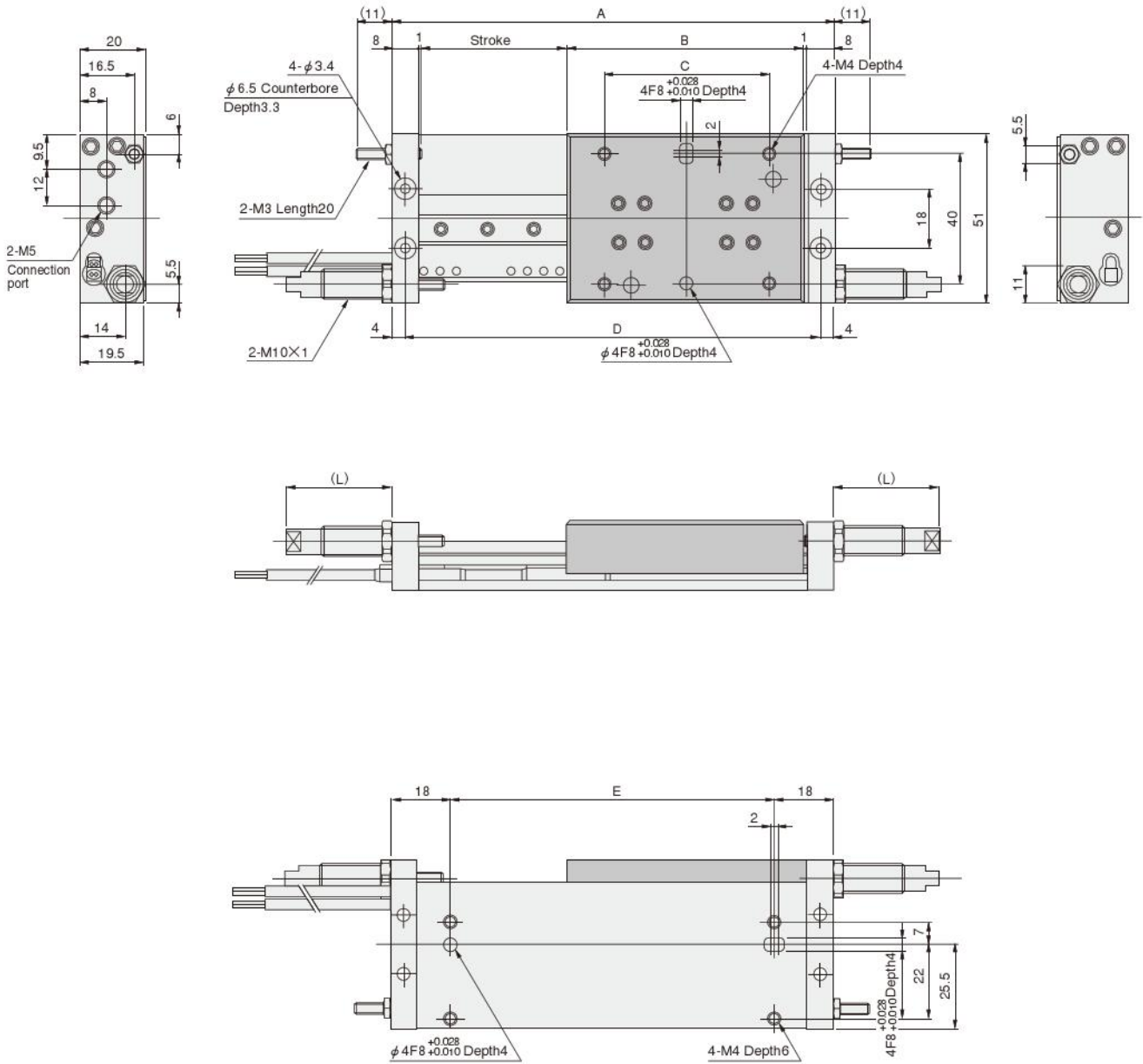

Shock Absorber L Dimension Table

Stroke	Code	A	B	C	D	E
15		91	58	35	83	55
30		106	58	35	98	70
45		136	73	50	128	100
60		166	88	65	158	130
75		196	103	80	188	160
90		226	118	95	218	190
105		256	133	110	248	220
120		286	148	125	278	250

L dimension	MIN.	MAX.
-A(KSHA6 X5-A)	9.5	17.5
-B(KSHA6 X5-B)	9.5	17.5
-C(KSHA6 X5-D)	9.5	17.5
-D(KSHA6 X5-DE)	9.5	17.5
-E(KSHA6 X8-D)	24	32
-F(KSHA6 X8-E)	24	32
-G(KSHA6 X8-F)	24	32

● $\phi 16$ [0.630in.] ● Maximum load capacity 19.6N [4.4lbf.] (With shock absorbers)

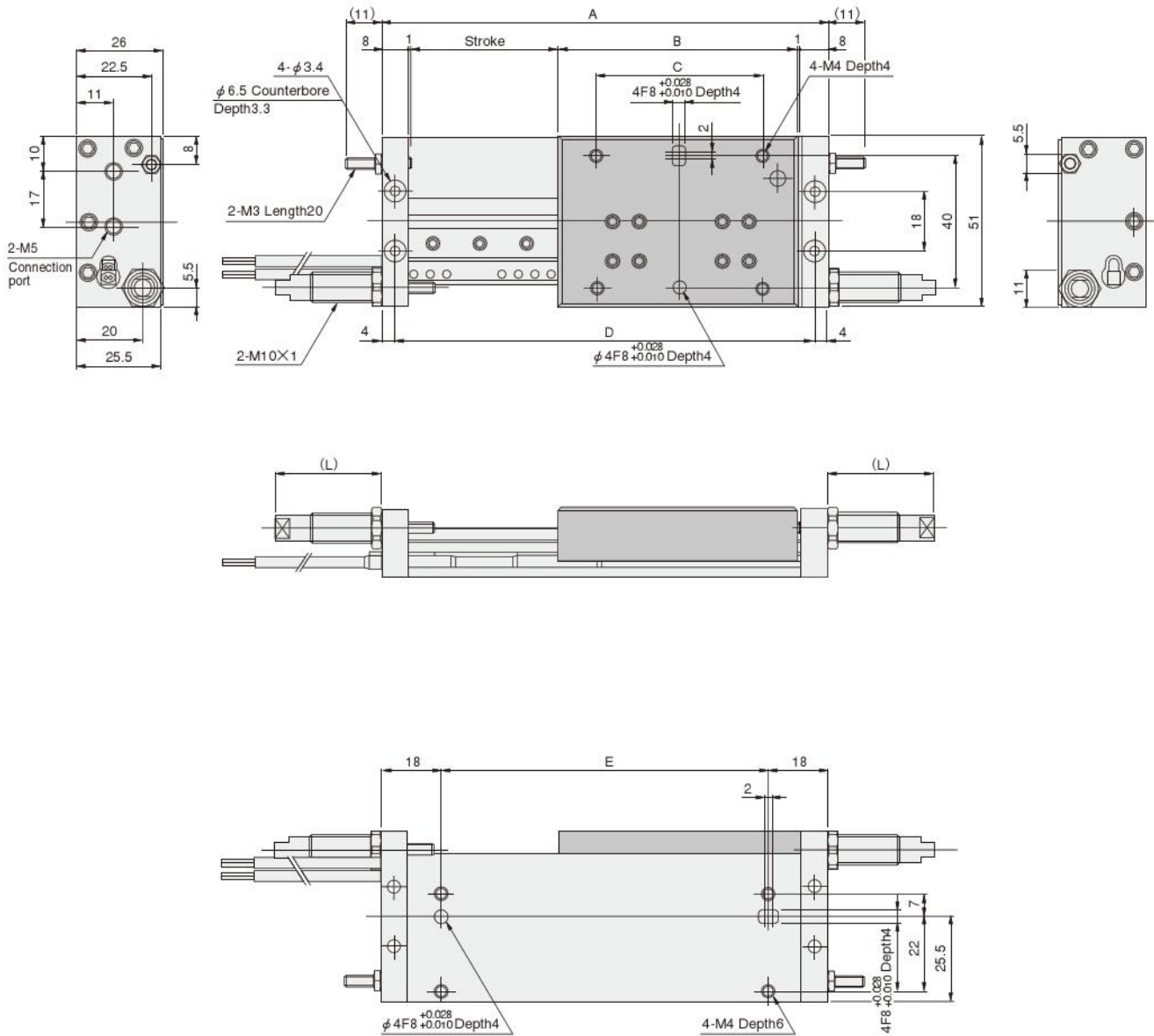

GT SLIDE TABLES (B AND C TYPES)

Stroke	Code	A	B	C	D	E
15		91	58	35	83	55
30		106	58	35	98	70
45		136	73	50	128	100
60		166	88	65	158	130
75		196	103	80	188	160
90		226	118	95	218	190
105		256	133	110	248	220
120		286	148	125	278	250

Shock Absorber L Dimension Table

Model	L dimension	MIN.	MAX.
-A(KSHA6 X5-A)		9.5	17.5
-B(KSHA6 X5-B)		9.5	17.5
-C(KSHA6 X5-D)		9.5	17.5
-D(KSHA6 X5-DE)		9.5	17.5
-E(KSHA6 X8-D)		24	32
-F(KSHA6 X8-E)		24	32
-G(KSHA6 X8-F)		24	32

Handling Instructions and Precautions



Sensor switch

Mounting location of end of stroke detection sensor switch

When the sensor switch is mounted in the locations shown below (the figures in the tables are reference values), the magnet comes to the maximum sensing location of the sensor switch at the end of the stroke.

●AGTC

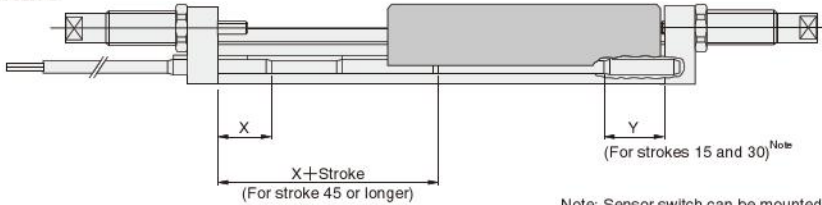

Note: Sensor switch can be mounted on stroke 45 or longer.

●AGTB

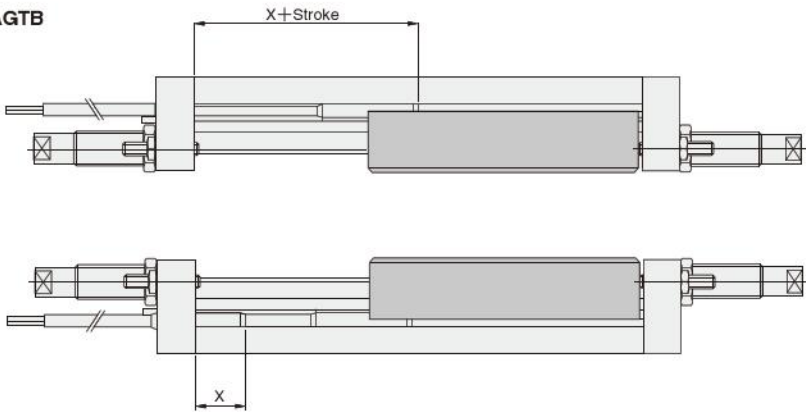

mm [in.]

Sensor switch	X	Y
ZC301	11 [0.433]	19 [0.748]
ZC305	14.5 [0.571]	19.5 [0.768]
ZC330	12.5 [0.492]	20.5 [0.807]
ZC353	12.5 [0.492]	20.5 [0.807]

Mounting

Mount the sensor switch so that the SUS plate surface faces up.

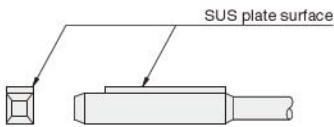

Caution: Mount the sensor switch using the supplied hexagon socket setscrews. Tighten the hexagon socket setscrew with a tightening torque of 19.6 N·cm [1.7in·lbf]. Overtightening could damage the sensor switch.



General precautions

Piping

Always thoroughly blow off (use compressed air) the tubing before connecting it to the cylinder. Entering chips, sealing tape, rust, etc., generated during piping work could result in air leaks or other defective operation.

Atmosphere

1. If using in locations subject to dripping water, dripping oil, etc., or to large amounts of dust, use a cover to protect the unit.
2. The product cannot be used when the media or ambient atmosphere contains any of the substances listed below.
Organic solvents, phosphate ester type hydraulic oil, chlorine gas, or acids, etc.

Lubrication

Inside cylinder of this product can be used without lubrication, if lubrication is required, use Turbine Oil Class 1 (ISO VG32) or equivalent.

Avoid using spindle oil or machine oil.

Periodic greasing is required for the outside surface of the cylinder body.

Apply the recommended grease sufficiently every 300km [186mi.] of traveling distance.

Recommended grease: Lithium soap-based grease

Atmosphere

1. Use air for the media. For the use of any other media, consult us.
2. Air used for the cylinder should be clean air that contains no deteriorated compressor oil, etc. Install an air filter (filtration of a minimum 40 μm) near the cylinder or valve to remove collected liquid or dust. In addition, drain the air filter periodically.