



CAD drawing data catalog  
is available.



# KOGANEI

## ACTUATORS GENERAL CATALOG



# YZ MODULES CONTENTS

Features	1031
Application Examples of the Y Axis Module	1034
Application Examples of the Z Axis Module	1035
ACY Specifications	1037
Order Codes	1038
Dimensions	1040
ACZ Specifications	1042
Order Code	1043
Dimensions	1045
Handling Instructions and Precautions	1047

# Discontinued

YZ MODULES

 **Caution** Before use, be sure to read the "Safety Precautions" on p. 57.

# Plus precision

## alpha series YZ modules

We have added advanced positioning precision and high rigidity to the pneumatic actuator.

The Koganel Alpha Series further enhances the drive module concept, supporting superior applications and labor savings in FA line design and manufacturing with higher performance.



The YZ module easily upgrades the Y, Z axis system, even incorporating handling operations in a single system. With the objectives of high rigidity and advanced performance, 2 linear guide mechanisms on each of the 2 axes respond to heavy loads and high precision. Moreover, new technologies, such as a newly developed intermediate stopper unit mounted on the double acting cylinder, a compact embedded sensor switch, and shortened design hours and manufacturing times for automated systems in the Y, Z axis movement, demonstrate the unit's total cost performance.



### Intermediate stops possible!

- A double acting cylinder and shock absorbers compose an intermediate stopper unit that enables intermediate stops at required positions.
- Improved stopping position accuracy at the end of the stroke, and a single orifice type shock absorber suitable for shocks at low speeds.

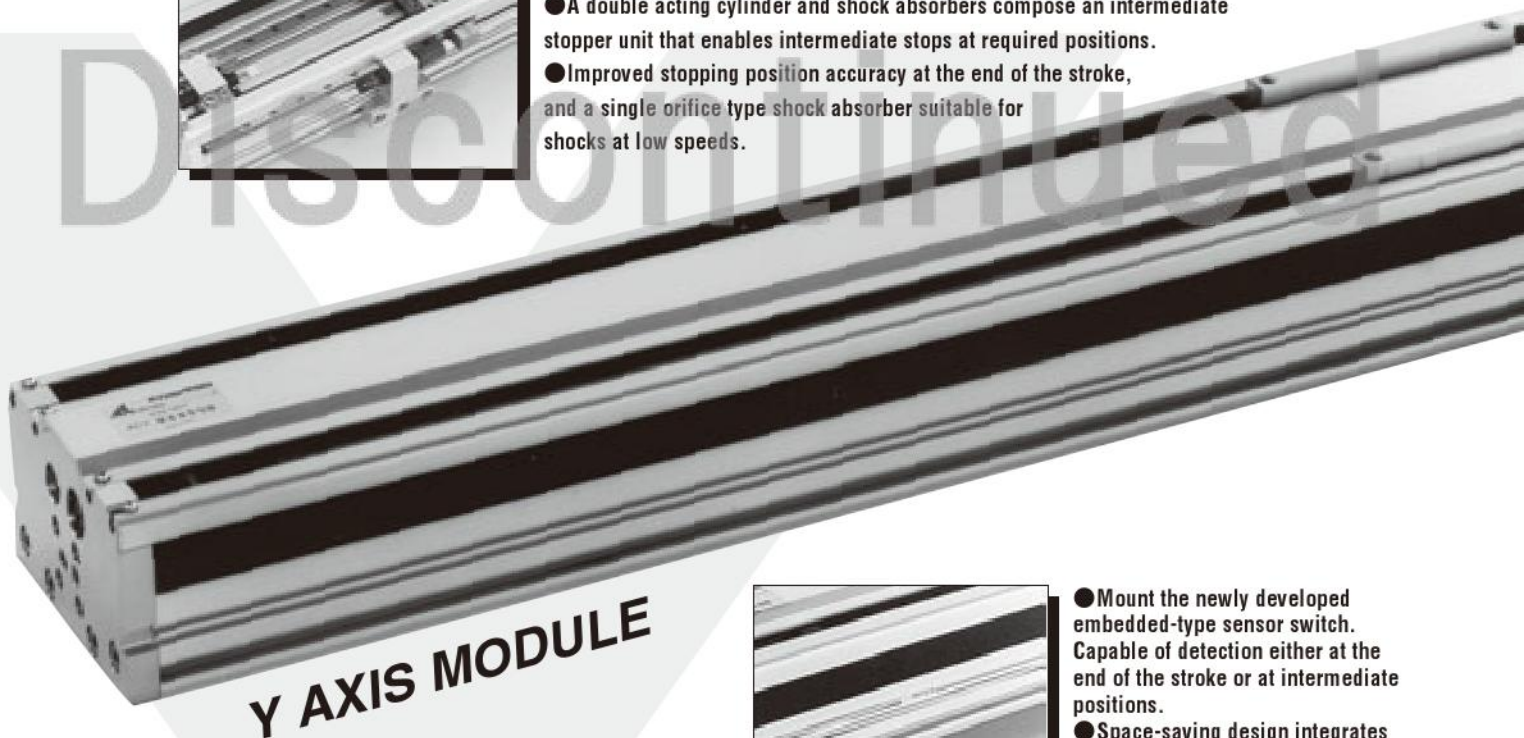

Y AXIS MODULE



- Mount the newly developed embedded-type sensor switch. Capable of detection either at the end of the stroke or at intermediate positions.
- Space-saving design integrates wiring and piping into a single plane.



- T-slots with built-in square nuts are arranged in 2 rows along the bottom of the body, and in 1 row along each side, to increase flexibility and ease of mounting.

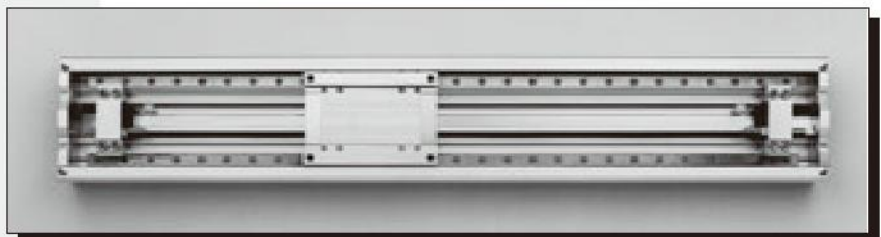

- Use a rodless cylinder with field-proven high reliability and ease of control.
- Two linear guides assure rigidity and linearity and respond to heavy loads.

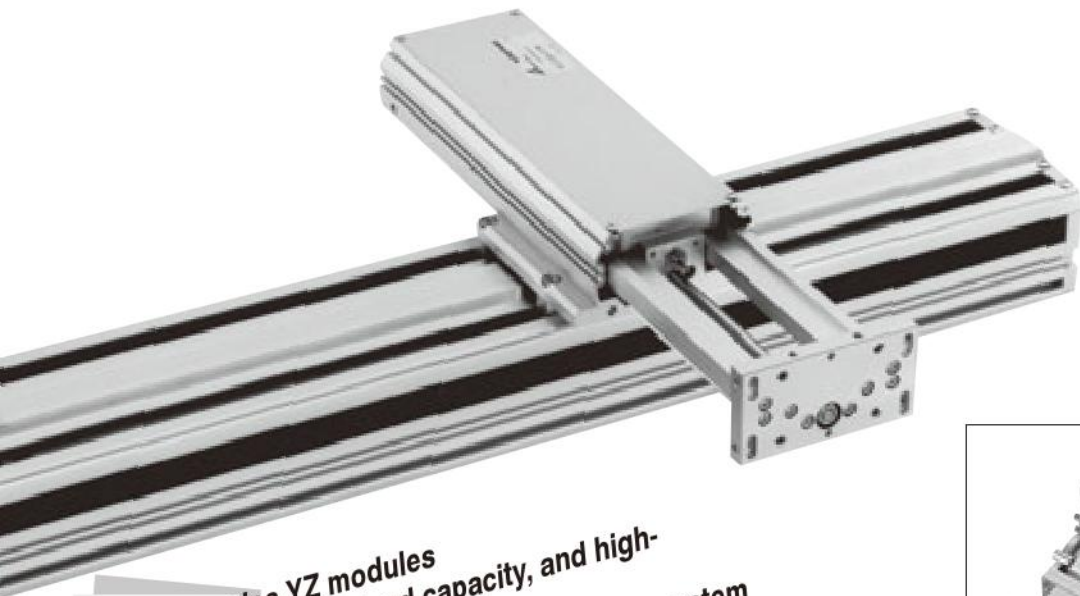

Alpha series YZ modules  
 Achieve a heavier load capacity, and high-precision system,  
 Achieve total upgrade performance as a system

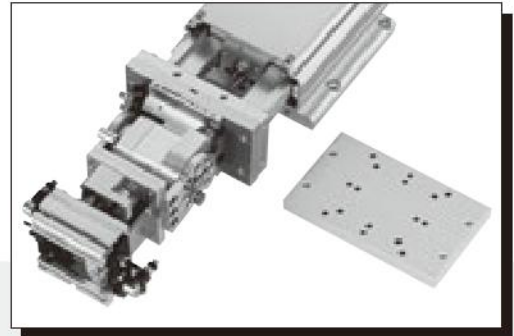

● Handling modules in S, M, L sizes can be attached to the end plate.

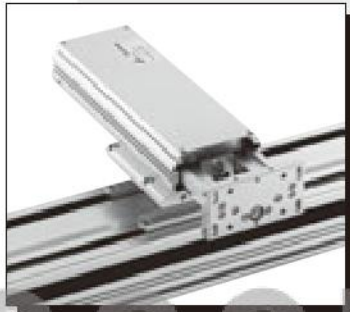

● The mounting method uses bolts only for easy upgrades of the system.

(ACY16 and ACZ20 : M6 × 1)  
 (ACY25 and ACZ25 : M8 × 1.25)



● A cover enclosing the body provides clean exterior and safety.

● A newly developed sensor switch can be mounted in any location along the groove, for detection either at the end of the stroke or at intermediate positions.

● A magnet for sensor switch is standard equipment for the cylinder body.

※ Up to a total of 5 sensor switches can be mounted, 3 for piston position detection and 2 for stopper unit position detection. For details, see p.1049.



Z AXIS MODULE



● The 2 linear guides respond to the heavy load and high accuracy that cannot be achieved by the shaft type guides.



● Intermediate stopper unit ( $\phi 10$  [0.394in.] cylinder is built in) automatically switches between 2 descent positions (extended side).

● Stopper bolt adjusts stroke range of 20mm [0.787in.] or less.

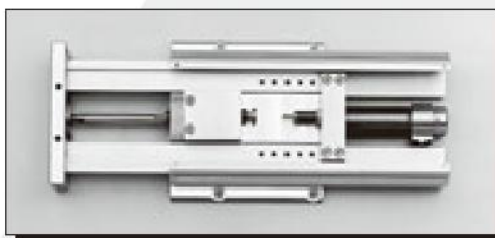

● Two shock absorbers also used as stopper bolts to improve stopping position accuracy at the end of the stroke are standard equipment.

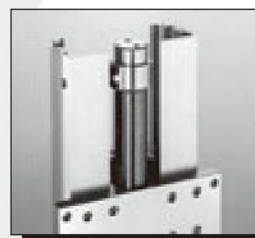

● End keep mechanism for prevention of unintended falls is optional.

# Benefits of the Y axis module (ACY)

**First and foremost,  
high rigidity!!**

**Cylinder thrust and rigidity comparison graph**

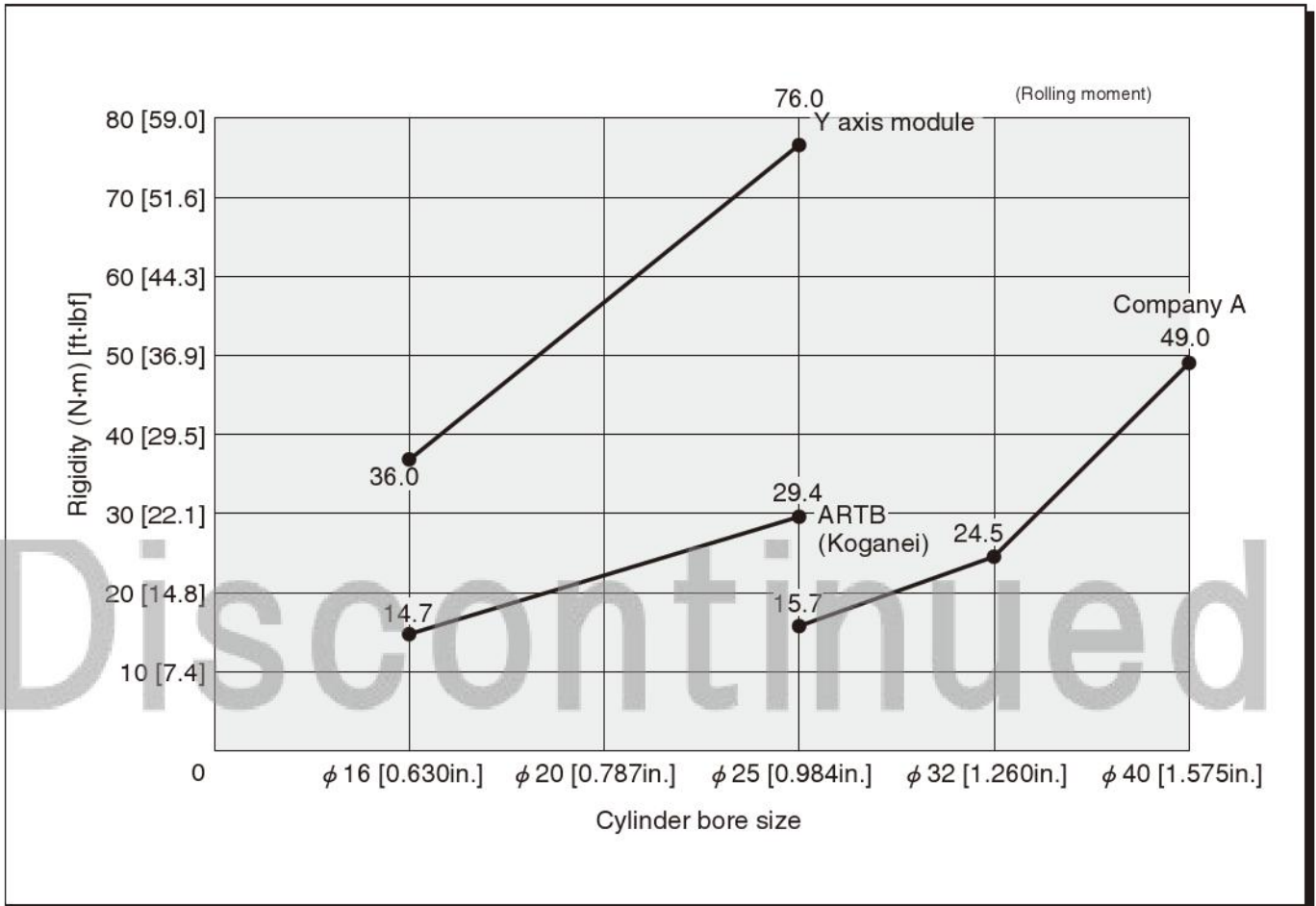

In previous air slide tables, increasing the rigidity meant increasing the bore size, which eventually led to higher costs. With the Y axis module, however, high rigidity is obtainable even without a bigger bore size and can be used as the X or Y axis, and the costs will really be lower than an equivalent!



Rigidity is really more important than thrust for the horizontal application shown in the illustration to the right. The Y axis module can be safely used even with larger overhang.

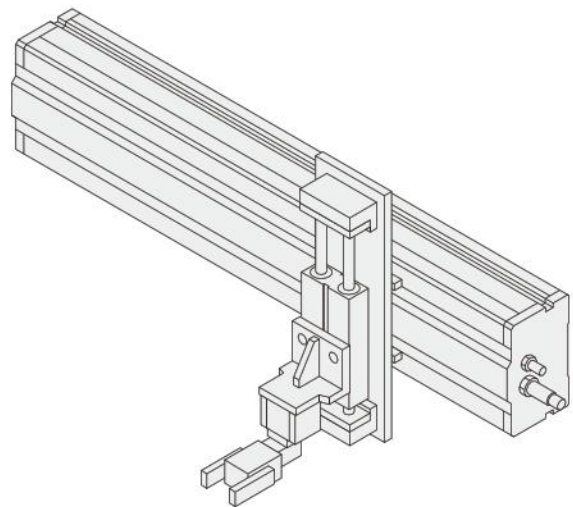

# Application examples of the Y axis module

- Uses 2 linear guides that assure rigidity and linearity, and that respond to heavy load and high accuracy needs.
- An intermediate stopper unit is built in, and moving the shock absorber improves intermediate stopping accuracy.
- The compact, embedded-type sensor switch is capable of detection at the end of the stroke and intermediate positions.

### ◆ Intermediate stopping with air slide tables

**Previously...**

Brake cylinder

- In a brake cylinder, the stopping position is unstable.
- The wiring and piping is also time-consuming.

Device, Line 1, Line 2

### ◆ Intermediate stopping with air slide tables

**With the Y axis module...**

This is the clincher.

Intermediate stopper

- Intermediate mechanical stopper assures stopping position accuracy.
- Air circuits are also easily built!!

Device, Line 1, Line 2

Discontinued

YZ MODULES

### ◆ As a table

**Single axis robot**

Workpiece loading, Operation, Transfer

A stop is needed at just one intermediate position. But since precision is also needed, we'll have to use an expensive robot.

### ◆ As a table

**Y axis module**

Workpiece loading, Operation, Transfer

This is the clincher.

With the Y axis module, accuracy of the intermediate stopper unit becomes obtainable, thus allowing construction of a low-cost system.

# Application examples of the Z axis module

- Uses 2 linear guides that assure rigidity and linearity, and that respond to heavy load and high accuracy needs.
- Capable of responding to 2 handling units. Moreover, its ability to reduce vibrations of workpieces mounting portions can shorten cycle time.
- An intermediate stopper unit is built in, making it possible to automatically switch between 2 descent positions (extended side).
- The handling module can be mounted if an optional plate is attached on the end plate portion. A locating pin is used to slide the plate with high accuracy, for fine positioning adjustment.

## ◆ As a Z-axis for pick-and-place

### Previously...



It's so hard to pick and place for lines on different levels!

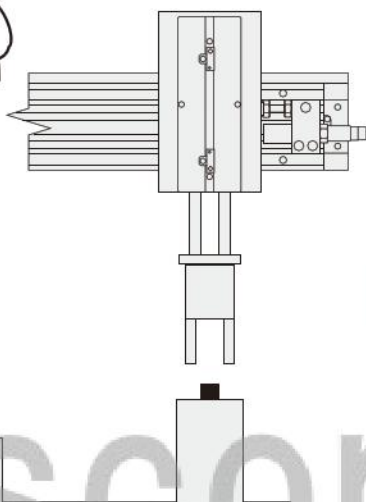

## ◆ As a Z-axis for pick-and-place

### With the Z axis module...

- A single Z-axis module is enough to respond to pick-and-place on different levels by switching the strokes.

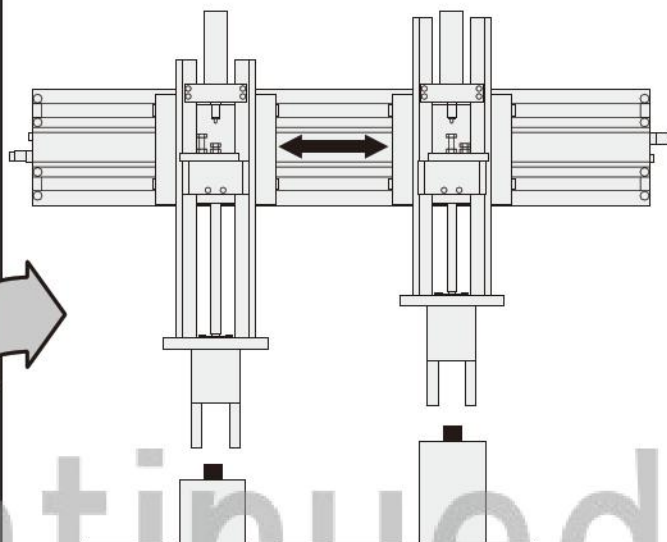

## ◆ As a single Item

### Pick-and-place in combination with other actuators

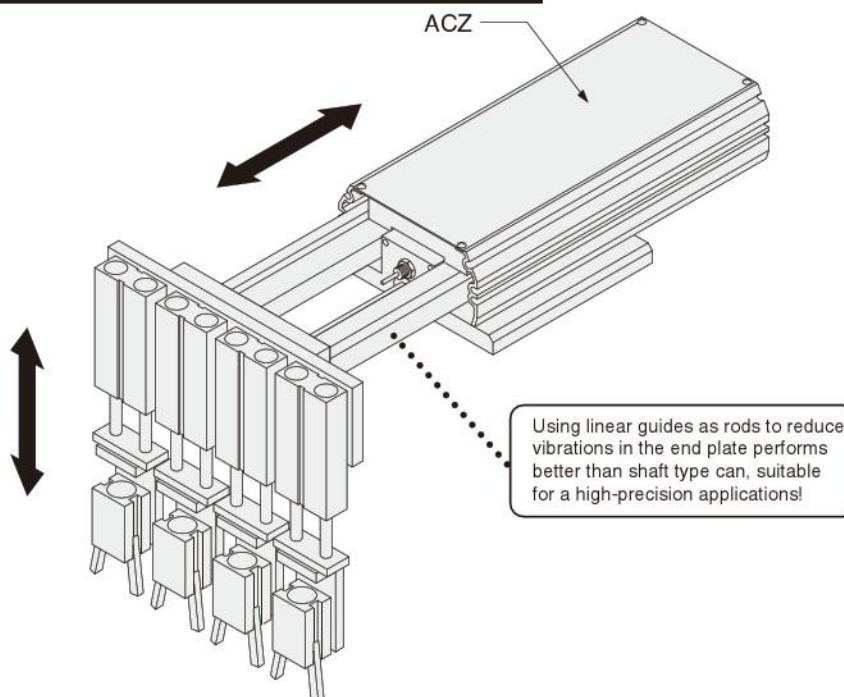

● The system, including everything as a Y-, Z-axis drive module with the handling function, can be constructed in a short time.

**Previously...**

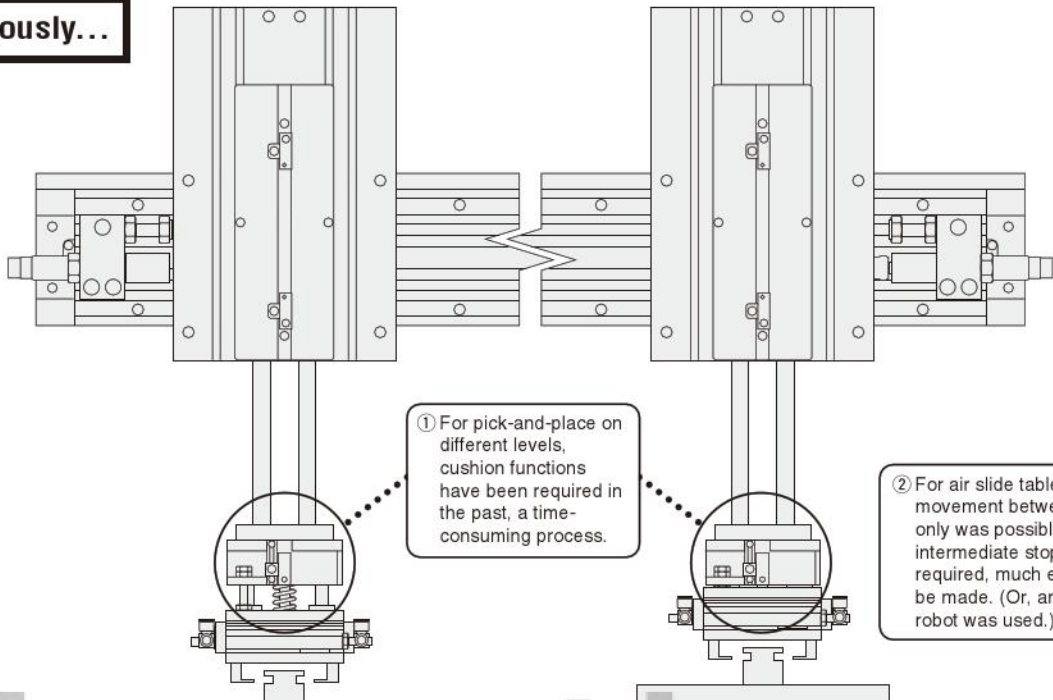

Discontinued

**With the YZ module...**

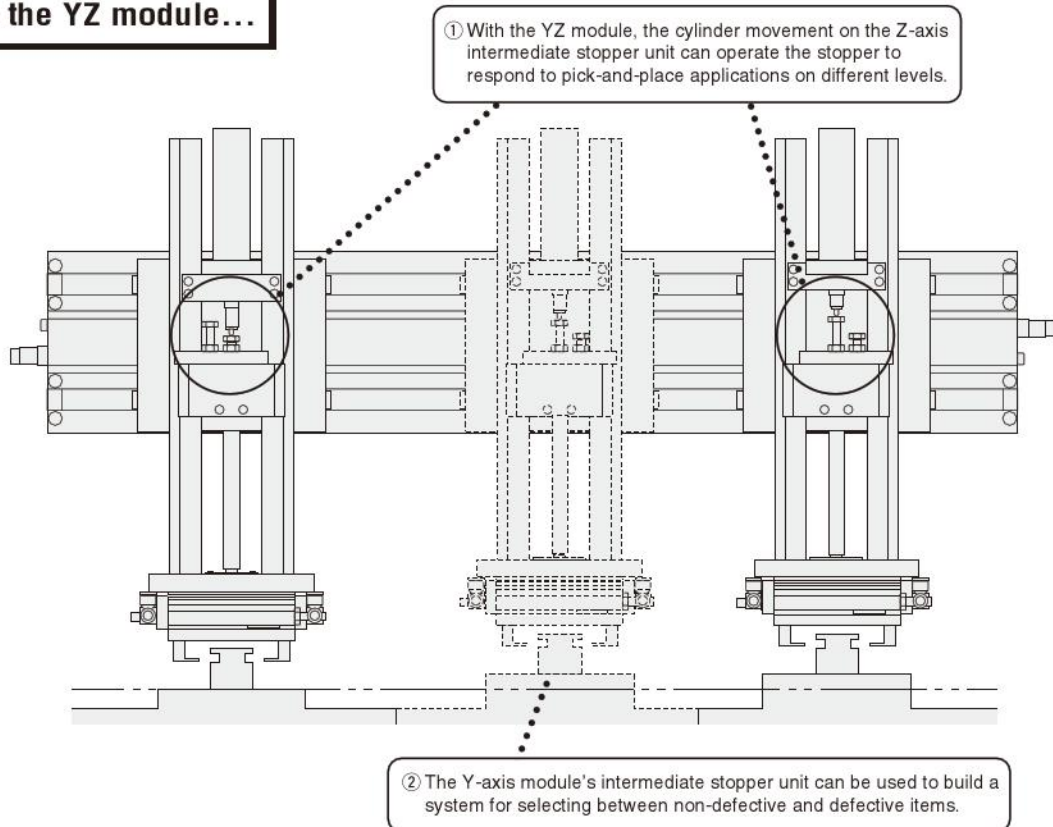

# YZ MODULES

## ACY Specifications



### Specifications

Item	Model	ACY16	ACY25
Bore size	mm [in.]	16 [0.630]	25 [0.984]
Operation type		Double acting type	
Media		Air	
Operating pressure range	MPa [psi.]	0.15~0.8 [22~116]	
Proof pressure	MPa [psi.]	1.2 [174]	
Operating temperature range	°C [°F]	0~60 [32~140]	
Operating speed range	mm/s [in./sec.]	200~1000 [7.9~39.4]	
Cushion		With shock absorber (on both sides)	
Lubrication	Cylinder portion	Not required (If lubrication is required, use Turbine Oil Class 1 [ISO VG32] or equivalent.)	
	Guide portion	Required (Lithium soap-based grease) <sup>Note1</sup>	
Repeatability	mm [in.]	±0.02 [±0.0008] (Repeatability for intermediate stopping ±0.02 [±0.0008])	
Traveling parallelism	mm [in.]	0.1/300 [0.004/11.81]	
Stroke adjusting range	mm [in.]	Possible from 0 to specified strokes.	
Intermediate stopping mechanism		Available as an option (Full stroke adjustment)	
Mountable Z axis module model		ACZ20	ACZ25
Maximum load capacity <sup>Note2</sup>	N [lbf.]	196.1 [44.1]	392.2 [88.2]
Port size		Rc1/8	

Notes: 1. Apply grease on the raceway surface of the track rail every 6 months or every 300km [186mi.] of traveling distance.  
2. For the relationship between the mass and piston speeds, see the shock absorber performance graph on p.1039.

### Intermediate Stopper Unit Cylinder Portion Specifications

Item	Model	ST-ACY16	ST-ACY25
Applicable cylinder model		ACY16	ACY25
Bore size	mm [in.]	10 [0.394]	16 [0.630]
Stroke	mm [in.]	20 [0.787]	25 [0.984]
Operation type		Double acting type	
Media		Air	
Operating pressure range	MPa [psi.]	0.3~0.7 [44~102]	0.2~0.7 [29~102]
Proof pressure	MPa [psi.]	1.05 [152]	
Operating temperature range	°C [°F]	0~60 [32~140]	
Operating speed range	mm/s [in./sec.]	50~500 [2.0~19.7]	
Cushion		Rubber bumper	
Lubrication		Not required (If lubrication is required, use Turbine Oil Class 1 [ISO VG32] or equivalent.)	
Port size		M5×0.8	
Installable sensor switch model		CS5T, CS11T, ZC130, ZC153	

### Shock Absorber Specifications

Item	Model	KSH6×10C	KSH8×10C
Applicable cylinder model		ACY16	ACY25
Maximum absorption	J [ft·lbf]	2.9 [2.14]	5.9 [4.35]
Absorbing stroke	mm [in.]	10 [0.394]	
Maximum impact speed	mm/s [in./sec.]	1000 [39.4]	
Maximum operating frequency	cycle/min	30	
Spring return force (When retracted)	N [lbf.]	9.2 [2.07]	15.7 [3.53]
Angle variation		3° or less	
Operating temperature range	°C [°F]	0~60 [32~140]	

Note: Shock absorbers for the intermediate stopper's shock absorber unit are the shock absorbers shown above with stopper nuts (-S) added.

## Bore Size and Stroke

mm		
Bore size	Standard strokes	Maximum available stroke
16	200, 300, 400, 500, 600	1000
25		

## Mass

		kg [lb.]						
Model	Basic mass					Additional mass of option		
	Stroke mm					Intermediate stopper unit <sup>Note</sup>	Shock absorber unit	Sensor switch for module body ZE101, ZE102, ZE135, ZE155
	200	300	400	500	600			
ACY16	5.9 [13.0]	6.7 [14.8]	7.4 [16.3]	8.3 [18.3]	9.1 [20.1]	0.71 [1.57]	0.18 [0.40]	0.015 [0.033] (For a lead wire of 1000mm [39in.])
ACY25	10.7 [23.6]	11.9 [26.2]	13.0 [28.7]	14.3 [31.5]	15.6 [34.4]	1.47 [3.24]	0.43 [0.95]	0.035 [0.077] (For a lead wire of 3000mm [118in.])

Note: Additional mass of intermediate stopper unit includes the sensor switch mass.

## Order Codes

**ACY 16 × 200** - [ ] - [ ] - [ ] - [ ] - [ ] - [ ] - [ ]

**Bore size × Stroke**  
Alpha series Y axis module

**Intermediate stopper unit**  
Blank : No stopper unit  
ST1 : With stopper unit (with 1 shock absorber unit)  
ST2 : With stopper unit (with 2 shock absorber units)

The intermediate stopper unit at shipping is installed on the right side as viewed from the connection port of the Y axis module.

**Sensor switch for module**  
Blank : No sensor switch  
ZE101 : Reed switch type without indicator lamp horizontal lead wire DC5~28V AC85~115V  
ZE102 : Reed switch type with indicator lamp horizontal lead wire DC5~28V AC85~115V  
ZE135 : Solid state type with indicator lamp horizontal lead wire DC10~28V  
ZE155 : Solid state type with indicator lamp horizontal lead wire DC4.5~28V

● For details of sensor switches, see p.1544.

**Lead wire length**  
A : 1000mm [39in.]  
B : 3000mm [118in.]

**Number of sensor switches**  
1 : With 1 sensor switch  
2 : With 2 sensor switches  
3 : With 3 sensor switches  
4 : With 4 sensor switches  
5 : With 5 sensor switches

**Lead wire length**  
A : 1000mm [39in.]  
B : 3000mm [118in.]

**Number of sensor switches**  
1 : With 1 sensor switch  
2 : With 2 sensor switches

**Sensor switch for intermediate stopper**  
Blank : No sensor switch  
CS5T : Reed switch type without indicator lamp DC5~28V AC85~115V  
CS11T : Reed switch type with indicator lamp DC10~28V  
ZC130 : Solid state type with indicator lamp DC10~28V  
ZC153 : Solid state type with indicator lamp DC4.5~28V

※ When selecting an intermediate stopper unit as an option, the actual stroke is shortened.  
For details, see the dimensions on p.1040~1041.

YZ MODULES

### ● Order codes for options only

#### Intermediate stopper unit

**ST-ACY** [ ]

**Bore size**  
16 : For  $\phi$  16 [0.630in.]  
25 : For  $\phi$  25 [0.984in.]

Cylinder basic type

#### Shock absorber unit for intermediate stopper unit

**K-ACY** [ ]

**Bore size**  
16 : For  $\phi$  16 [0.630in.]  
25 : For  $\phi$  25 [0.984in.]

Cylinder basic type

#### Sensor switch (with holder) for intermediate stopper unit

[ ] **ACY** [ ]

**Cylinder basic type**

**Lead wire length**  
A : 1000mm [39in.]  
B : 3000mm [118in.]

**Sensor switch**  
CS5T  
CS11T  
ZC130  
ZC153

#### Sensor holder for intermediate stopper unit only

**C1-ACY**

**Cylinder basic type**

※ Sensor holders for the intermediate stopper are the same regardless of bore sizes. (The sensor holder for the Knock cylinder is used.)

#### Sensor switch for slide table only

[ ] **-ACY** [ ]

**Cylinder basic type**

**Lead wire length**  
A : 1000mm [39in.]  
B : 3000mm [118in.]

**Sensor switch**  
ZE101  
ZE102  
ZE135  
ZE155

# Shock Absorber Performance Graph

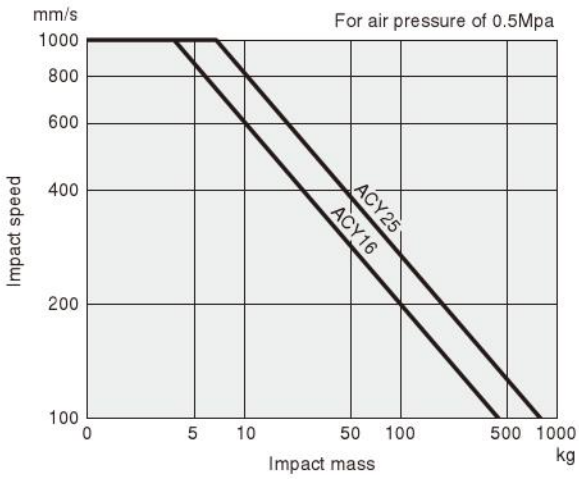

1mm/s = 0.0394in./sec.  
1kg = 2.205lb.

# Allowable Bending Moment and Displacement

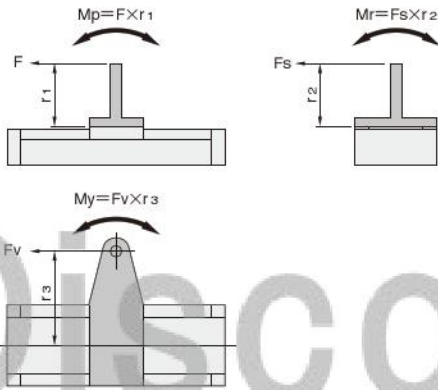

## ● Bending moment and displacement

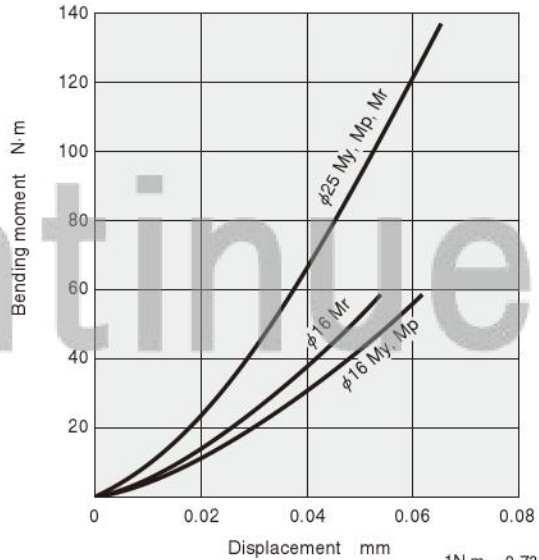

1N·m = 0.7376ft·lbf  
1mm = 0.0394in.

## ● Allowable Bending Moment

Bore mm [in.]	Direction of moment	N·m [ft·lbf]		
		Pitching (Mp)	Yawing (My)	Rolling (Mr)
16 [0.630]		28 [20.7]	32 [23.6]	36 [26.6]
25 [0.984]		70 [51.6]	79 [58.3]	76 [56.1]

## Dimensions of ACY16 (mm)

●  $\phi 16$  [0.630in.] ● Double acting type ● Maximum load capacity 196.1N [44.1lbf.]



ACY16

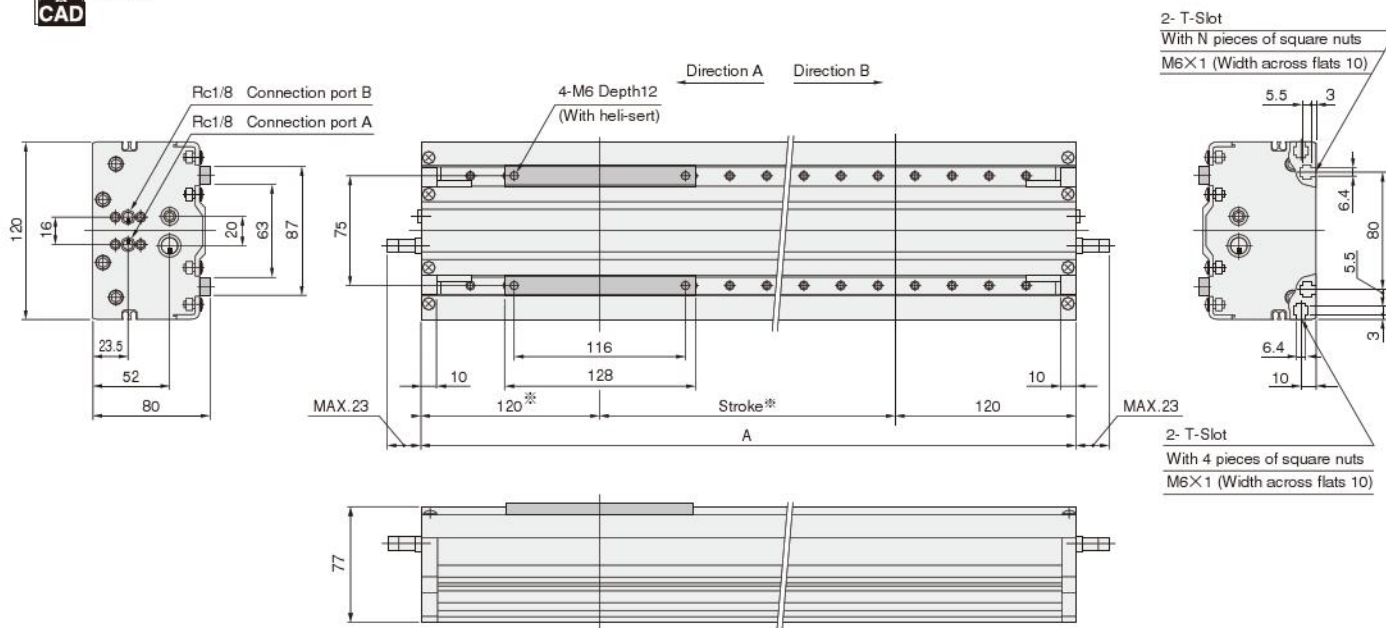

Stroke	Code	A	N
200		440	4
300		540	4
400		640	6
500		740	6
600		840	8

### Intermediate Stopper Unit: -ST

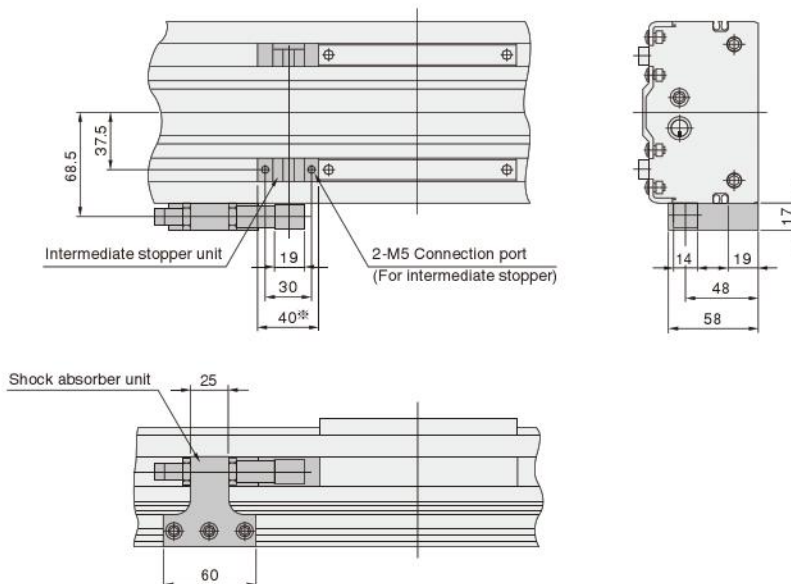

※ Even with the intermediate stopper unit mounted, the total length (dimension A) remains the same as in the above table. Consequently, the stroke is shortened by the length of the intermediate stopper unit.  
 (Example) For a 200mm stroke with an intermediate stopper unit,  
 Stroke = 440 - (120 + 120 + 40)  
 Stroke = 160 is the actual stroke.

# Dimensions of ACY25 (mm)

●  $\phi$  25 [0.984In.] ● Double acting type ● Maximum load capacity 392.2N [88.2lbf.]

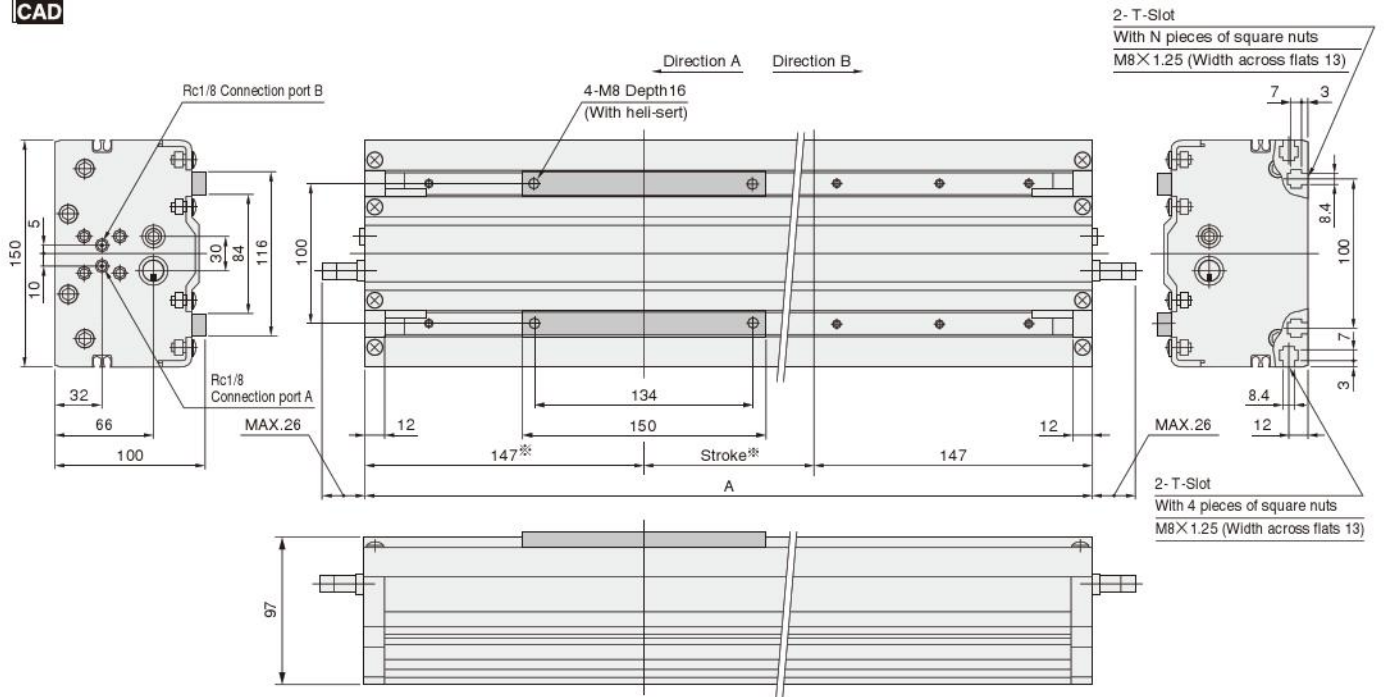

Stroke	Code	A	N
200		494	4
300		594	4
400		694	6
500		794	6
600		894	8

Discontinued

## Intermediate Stopper Unit: -ST □

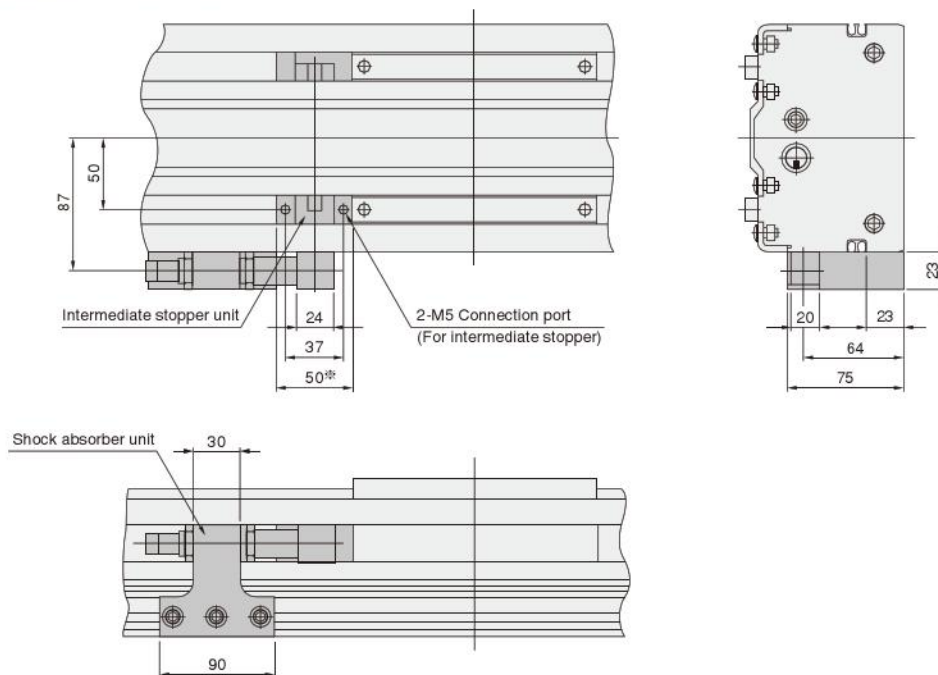

※ Even with the intermediate stopper unit mounted, the total length (dimension A) remains the same as in the above table. Consequently, the stroke is shortened by the length of the intermediate stopper unit.  
 (Example) For a 200mm stroke with an intermediate stopper unit,  
 Stroke = 494 - (147 + 147 + 50)  
 Stroke = 150 is the actual stroke.

# YZ MODULES

## ACZ Specifications



### Specifications

Item	Model	ACZ20	ACZ25	
Bore size	mm [in.]	20 [0.787]	25 [0.984]	
Operation type		Double acting type		
Media		Air		
Operating pressure range	MPa [psi.]	0.2~0.7 [29~102]		
Proof pressure	MPa [psi.]	1.05 [152]		
Operating temperature range	°C [°F]	0~60 [32~140]		
Operating speed range	mm/s [in./sec.]	150~500 [5.9~19.7]		
Cushion		With shock absorber		
Lubrication	Cylinder portion	Not required (If lubrication is required, use Turbine Oil Class 1 [ISO VG32] or equivalent.)		
	Guide portion	Required (Lithium soap-based grease) <sup>Note1</sup>		
Repeatability	mm [in.]	±0.02 [±0.0008]		
Traveling parallelism	mm [in.]	0.1/100 [0.004/3.94]		
End plate perpendicularity	mm [in.]	0.1 [0.004]		
Stroke adjusting range	mm [in.]	-50~+0 [-1.97~+0]		
Fall prevention mechanism		Option (Head side lock only)		
	Maximum holding force	N [lbf.]	194.2 [43.7]	303 [68.1]
	Backlash (at end keep)	mm [in.]	1.4 [0.055] or less	1.4 [0.055] or less
Intermediate stopping mechanism		Option (Two-staged switching on the end of the extended side, with a difference of 20mm or less between the first stage and the second stage) <sup>Note2</sup>		
Mountable handling module size		S, M	S, M, L	
Maximum load capacity <sup>Note3</sup>	N [[lbf.]	58.8 [13.2]	98.1 [22.1]	
Port size		M5×0.8	Rc1/8	

- Notes: 1. Apply grease on the raceway surface of the track rail every 6 months or every 300km [186mi.] of traveling distance.  
 2. Consult us when a stopping position difference of more than 20mm [0.787in.] is required.  
 3. For the relationship between the mass and piston speeds, see the shock absorber performance graph on p.1044.

	Push side stroke adjusting range		mm [in.]
	Adjusting range using stopper bolt	Adjusting range using shock absorber mount	
With stopper unit	Stopper bolt A ℓ=25	+ 0 [+0] -10 [-0.39]	+ 0 [+0] -50 [-1.97] (Settings available with 10mm [0.39in.] pitch)
	Stopper bolt B ℓ=35	-10 [-0.39] -20 [-0.79]	
Without stopper unit	Stopper bolt A ℓ=25	+ 0 [+0] -10 [-0.39]	

	Pull side stroke adjusting range	
	With end keep	Without end keep
With end keep	Prohibited	
Without end keep	+ 0 [+0]	-15 [-0.59]

### Shock Absorber Specifications

Item	Model	KSHA6×8-E	KSHA7×8-G
Applicable cylinder model		ACZ20	ACZ25
Maximum absorption	J [ft·lbf]	2.0 [1.5]	3.9 [2.9]
Absorbing stroke	mm [in.]	8 [0.315]	
Maximum impact speed	mm/s [in./sec.]	1000 [39.4]	
Maximum operating frequency	cycle/min	30	
Spring return force (When retracted)	N [lbf.]	9.8 [2.2]	
Angle variation		3° or less	
Operating temperature range	°C [°F]	0~60 [32~120]	

## Bore Size and Stroke

mm		
Bore size	Standard strokes	Maximum available stroke
20	50, 100, 150, 200	500
25		

## Mass

Model	Basic mass				Additional mass of option				
	Stroke mm				Intermediate stopper unit	Plate for handling module			Sensor switches ZE101, ZE102, ZE135, ZE155
	50	100	150	200		S	M	L	
ACZ20	2.00 [4.41]	2.30 [5.07]	2.60 [5.73]	2.90 [6.39]	0.12 [0.26]	0.2 [0.44]	0.25 [0.55]	—	0.015 [0.033] (For a lead wire of 1000mm [39in.])
ACZK20	2.05 [4.52]	2.35 [5.18]	2.65 [5.84]	2.95 [6.50]					
ACZ25	3.03 [6.68]	3.47 [7.65]	3.91 [8.62]	4.35 [9.59]	0.12 [0.26]	—	0.3 [0.66]	0.4 [0.88]	0.035 [0.077] (For a lead wire of 3000mm [118in.])
ACZK25	3.08 [6.79]	3.52 [7.76]	3.96 [8.73]	4.40 [9.70]					

## Order Codes

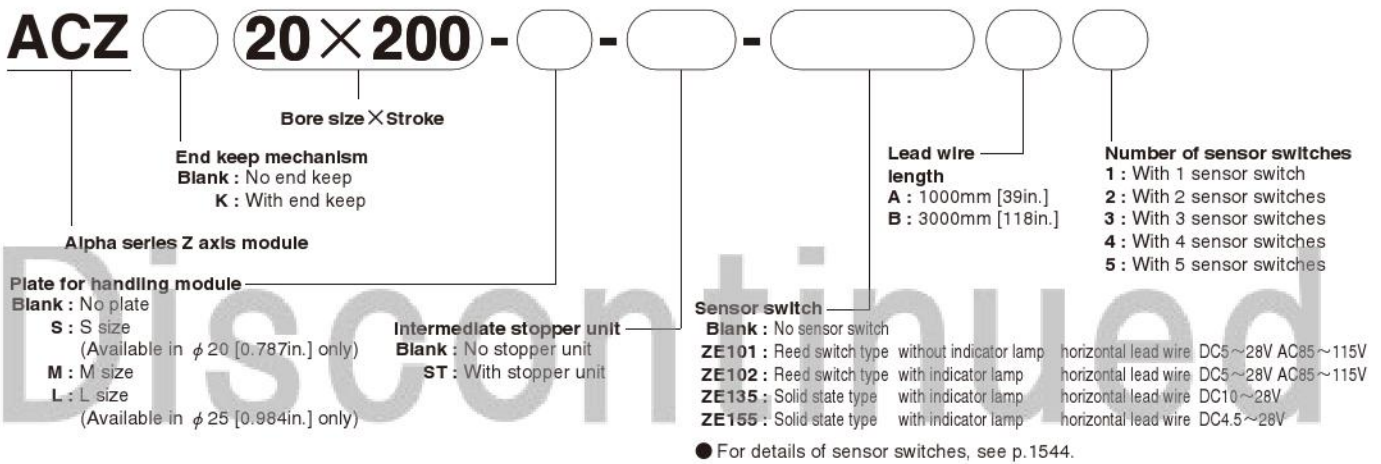

### ● Order codes for options only

#### Plate for handling module

□ -ACZ □

**Bore size**  
 20 : For φ 20 [0.787in.]  
 25 : For φ 25 [0.984in.]

**Cylinder basic type**

#### Intermediate stopper unit

ST-ACZ □

**Bore size**  
 20 : For φ 20 [0.787in.]  
 25 : For φ 25 [0.984in.]

**Cylinder basic type**

#### Shock absorber

KSHA □

6 × 8-E : For φ 20 [0.787in.]  
 7 × 8-G : For φ 25 [0.984in.]

**Shock absorber model**

S : S size (Available in φ 20 [0.787in.] only)

M : M size

L : L size (Available in φ 25 [0.984in.] only)

#### Sensor switch

□ -ACZ

**Lead wire length**  
 A : 1000mm [39in.]  
 B : 3000mm [118in.]

**Sensor switch**

ZE101

ZE102

ZE135

ZE155

## Shock Absorber Performance Graph (For vertical use)

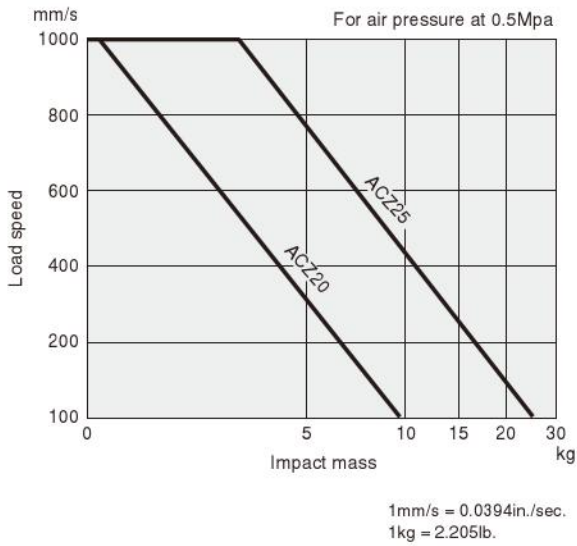

## Maximum Eccentricity at Plate End

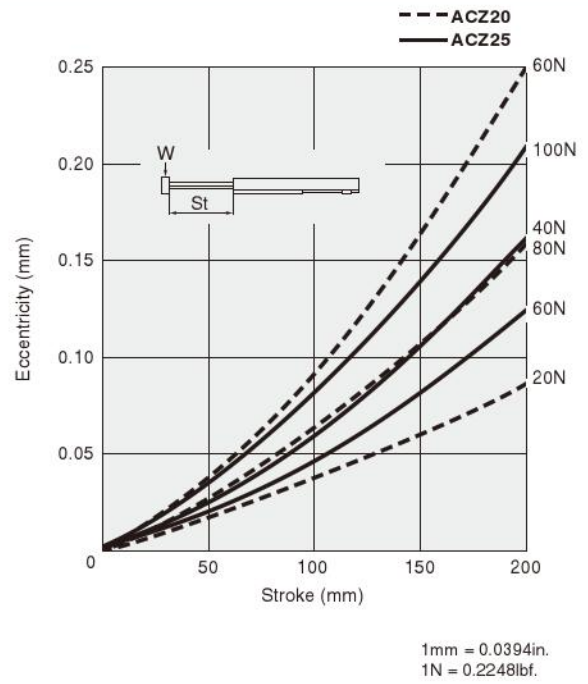

# Discontinued



# Dimensions of ACZ25 (mm)

●  $\phi 25$  [0.984in.] ● Double acting type ● Maximum load capacity 98.1N [22.1lbf.]

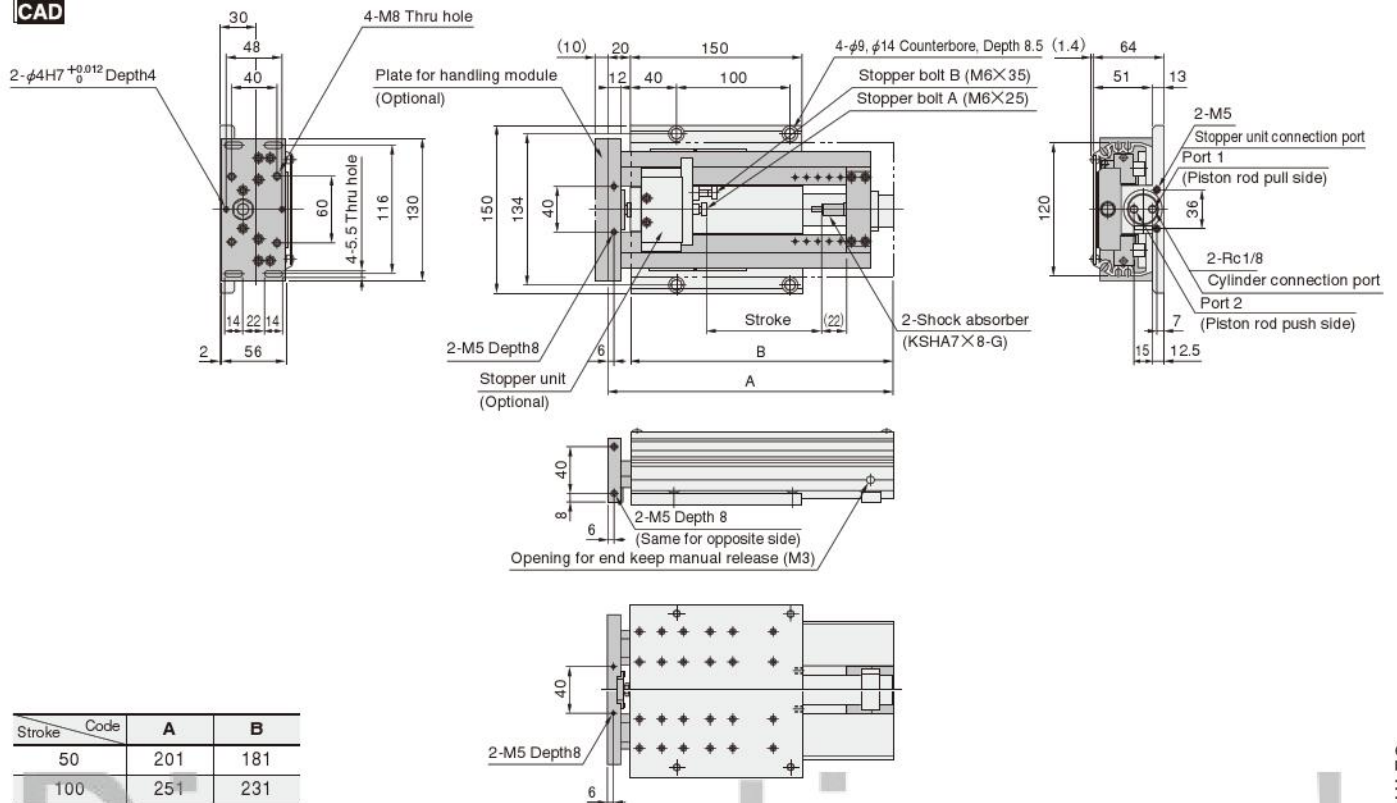

Stroke	Code	A	B
50		201	181
100		251	231
150		301	281
200		351	331

Discontinued

YZ MODULES

■ Plate for Handling Module: -M  
M size (Thickness 10mm [0.394in.])

■ Plate for Handling Module: -L  
L size (Thickness 10mm [0.394in.])

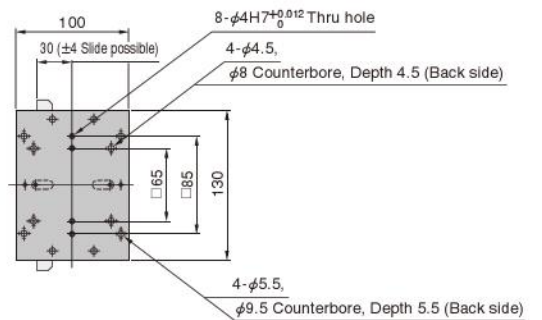
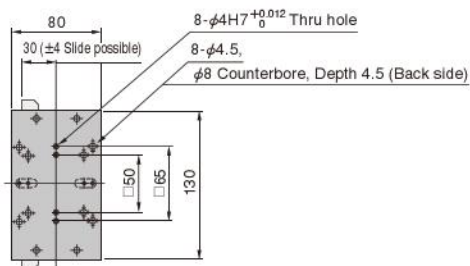

■ Shock Absorber: KSHA7 $\times$ 8-G

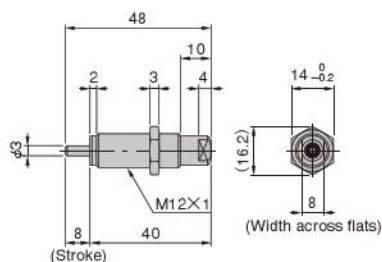



## Mounting

### ACY body mounting

1. For mounting the ACY body, use the square nuts in the 2 rows of T-slots on the bottom. Any mounting direction is allowed.
2. Avoid mounting that uses the square nuts on the body's side.

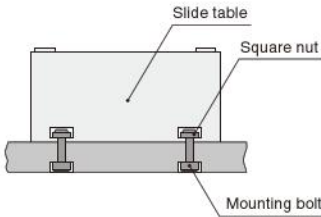

3. For the screw length of the mounting bolts used with the square nuts, we recommend the dimensions shown below.

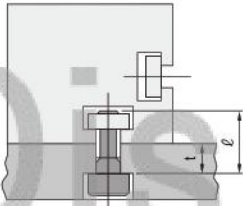

Screw length  $l$  mm [in.]

Model	ACY16	ACY25
Position		
Bottom	M6 t+9 [0.35]	M8 t+10 [0.39]
Side	M6 t+9 [0.35]	M8 t+10 [0.39]

4. Tighten the mounting bolt to the torque shown below.

Tightening torque N·m [ft·lbf]

Model	ACY16	ACY25
Position		
Bottom	9 [6.6] (M6)	22 [16.2] (M8)
Side	9 [6.6] (M6)	22 [16.2] (M8)

### ACZ body mounting

The mounting dimensions are designed for simple mounting that uses the bolts only.

- ACY16 and ACZ20: M6×1
- ACY25 and ACZ25: M8×1.25

### Intermediate stopper unit

1. The intermediate stopper unit can be mounted on the table in the left, right, up, or down directions, as shown in the diagrams below.

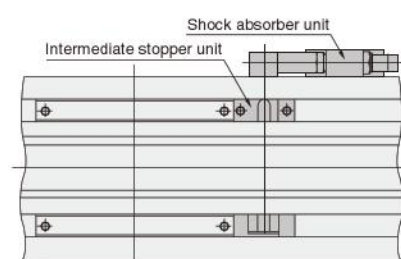
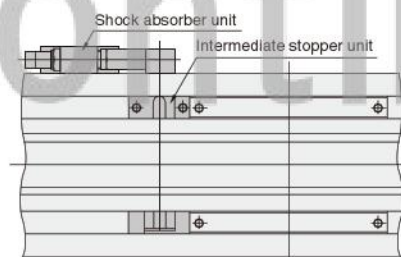
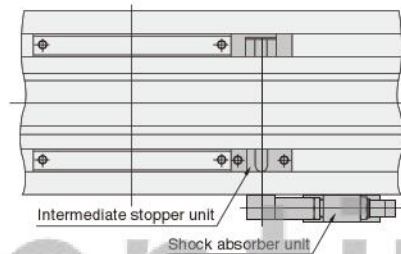
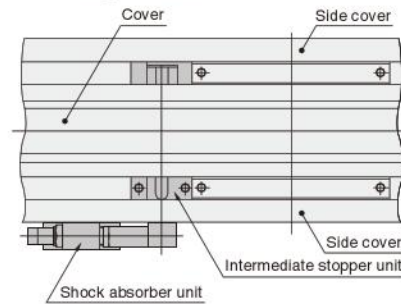

2. To remove the intermediate stopper unit in order to change its direction, remove the cover and side cover, loosen the hexagon socket head bolts at 3 locations on the intermediate stopper unit body, as shown in **Figure 1**, and then remove the unit.

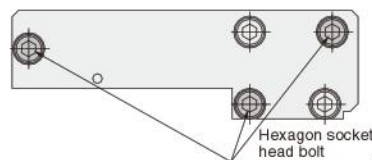

Figure 1

3. To mount the shock absorber in the opposite side on the table, first it is necessary to move the long nut inside the T-slot that is used to install the unit to the T-slot on the other side. In this case, the long nut can be moved by loosening the hexagon socket head bolts in 2 locations on the side plate positioned opposite the connection port (**Figure 2**) and then removing the side plate.

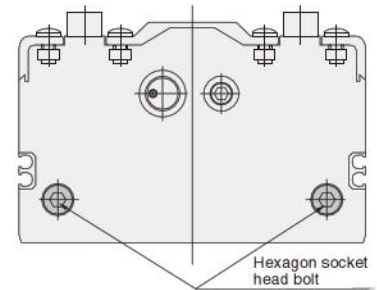

Figure 2

To move the table over the shock absorber unit after stopping at an intermediate position by operating the intermediate stopper unit, first reverse the direction of the supplying air to move the table backward in a moment, then retract the stopper on the intermediate stopper unit and again reverse the direction of the supplying air to move the table forward. (It is important to follow the steps shown in **Figure 3**.)

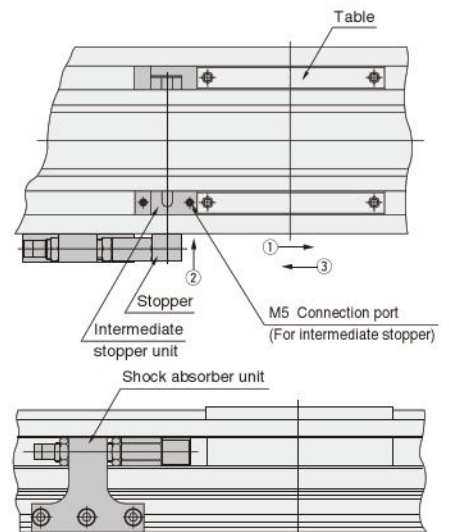

Figure 3



Shock absorber

**Adjustment**

1. Set the white mark of the shock absorption adjusting knob between 2 and 3 on the scale.
2. When the shock is too great at the end of the stroke, turn the adjusting knob toward 6 on the scale. Moreover, when the shock from impact is too great and/or the rod stops before the end of the stroke, turn the adjusting knob toward 0 on the scale.
3. After completing adjustment, always tighten the lock screw to secure the adjusting knob in place.



End keep cylinder

**Control circuit**

1. For control of the end keep cylinder **ACZK**, we recommend the use of 2-position, 4-, 5-port valves. Avoid the use of control circuit with ABR connection (exhaust center) 3-position valves that exhaust air from 2 delivery ports.
2. Always use meter-out control for speed control. Meter-in control may result in failure of the locking mechanism to release.
3. Always set the air pressure to 0.2~0.7MPa [29~102psi.].

- Cautions:**
1. It is dangerous to supply air to a connection port on a side with a locking mechanism while the cylinder has already been exhausted, because the piston rod may suddenly extend (or retract). In addition, since the lock piston could also cause galling of the lock piston and piston rod, resulting in defective operation. Always supply air to the connection port opposite the one adjacent to the locking mechanism to ensure applying back pressure.
  2. When restarting operations after air has been exhausted from the cylinder due to completion of operations or to an emergency stop, always start by supplying air to a connection port opposite the one adjacent to the locking mechanism.
  3. Connect the valve port A (NC) to the push side connection port.

**Manual operation of locking mechanism**

While the locking mechanism is normally released automatically through cylinder operations, it can also be released manually. For manual release, insert an M3×0.5 screw that has 55mm [2.17in.] screw length into the opening for end keep manual release, thread it in about 3 turns into the internal lock piston, and then pull up the screw. To maintain the manual override for adjustment, etc., thread the locknut onto the screw and, with the locking mechanism in a released state, tighten the locknut against the cylinder.

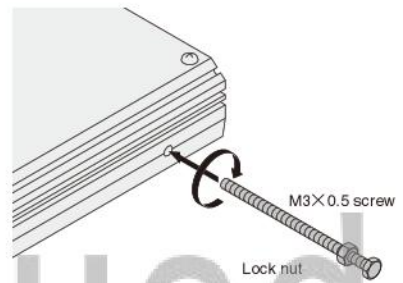

- Cautions:**
1. It is dangerous to release the lock when load (weight) is present on the piston rod, because it may cause the unintended piston rod's extension (or retraction). In this case, always supply air to the connection port opposite the one adjacent to the locking mechanism before releasing the locking mechanism.
  2. If the locking mechanism cannot easily be released even with manual override, it could be the result of galling of the lock piston and piston rod. In this case, supply air to the connection port opposite the one adjacent to the locking mechanism before releasing the locking mechanism.
  3. Water, oil, dust, etc., intruding through the opening for manual override may cause defective locks or other erratic operation. If using in locations subject to dripping water, dripping oil, etc., or large amounts of dust, use a cover to protect the unit.

Discontinued



## Sensor switch

### Mounting location of end of stroke detection sensor switch

When the sensor switch is mounted in the locations shown below (the figures in the tables are reference values), the magnet comes to the maximum sensing location of the sensor switch at the end of the stroke.

#### ● ACY16, 25

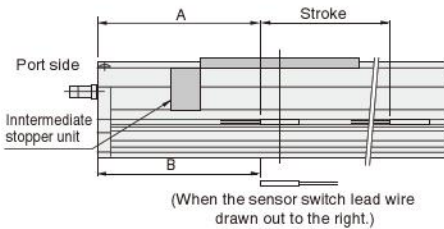

Sensor switch	mm [in.]							
	Without intermediate stopper				With intermediate stopper on the port side			
	ACY16		ACY25		ACY16		ACY25	
ZE135, ZE155	A	B	A	B	A	B	A	B
	111 [4.37]	114 [4.49]	188 [5.43]	141 [5.55]	151 [5.94]	154 [6.06]	188 [7.40]	191 [7.52]
ZE101, ZE102	A	B	A	B	A	B	A	B
	108 [4.25]	110 [4.33]	135 [5.31]	137 [5.39]	148 [5.83]	150 [5.91]	185 [7.28]	187 [7.36]

#### ● ACZ20, 25

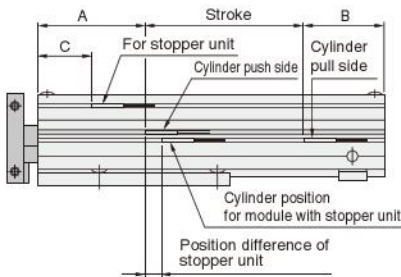

Sensor switch	mm [in.]					
	ACZ20			ACZ25		
	A	B	C	A	B	C
ZE135, ZE155	85 [3.35]	32 [1.26]	46 [1.81]	88 [3.46]	43 [1.69]	46 [1.81]
	81 [3.19]	36 [1.42]	42 [1.65]	84 [3.31]	47 [1.85]	42 [1.65]

### Mounting location

Piston position detection sensor switches A, B, and C can be mounted on either the left or right side. Care should be taken, however, when the staged stroke difference with an intermediate stopper unit is 10mm or less, there is a possibility of 2 piston position detection sensor switches on the push side turned on at the same time.

In that case, confirm the location of the above switches and the intermediate stopper position detection sensor switch.

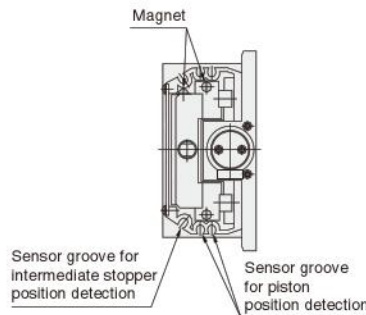
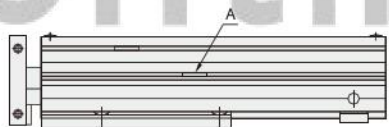
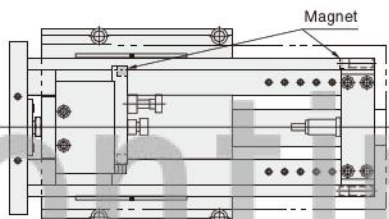
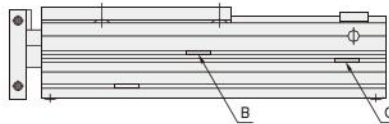

### Lead wire holder

ACY comes with 2 lead wire holders. Use them to protect the sensor switch lead wires, as shown in the illustration below.

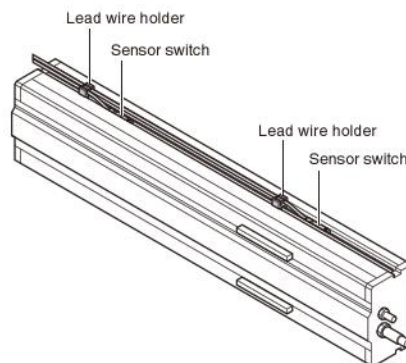

## General precautions

### Piping

Always thoroughly blow off (use compressed air) the tubing before connecting it to the cylinder. Entering chips, sealing tape, rust, etc., generated during piping work could result in air leaks or other defective operation.

### Atmosphere

1. If using in locations subject to dripping water, dripping oil, etc., or to large amounts of dust, use a cover to protect the unit.

2. The product cannot be used when the media or ambient atmosphere contains any of the substances listed below.

Organic solvents, phosphate ester type hydraulic oil, sulphur dioxide, chlorine gas, or acids, etc.

### Lubrication

The guide portion requires lubrication. Apply lithium soap-based grease on the raceway surface of the track rail in the guide portion every 6 months or every 300km [186mi.] of traveling distance. The cylinder portion can be used without lubrication. If lubrication is required, use Turbine Oil Class 1 (ISO VG32) or equivalent. Avoid using spindle oil or machine oil.

### Media

1. Use air for the media. For the use of any other media, consult us.

2. Air used for the cylinder should be clean air that contains no deteriorated compressor oil, etc. Install an air filter (filtration of a minimum 40 μm) near the cylinder or valve to remove collected liquid or dust. In addition, drain the air filter periodically.