

# SOLENOID VALVES 600 SERIES

A high flow-rate valve offering optimum performance with an effective area of 60mm<sup>2</sup> [Cv 3.33] for  $\phi$  100 [3.937in.]~  $\phi$  180 [7.087in.] air cylinder operation has been added to our product range.

The manifold is an user friendly base stacking type, for easy unit changes.

All combinations of combined mountings are possible, for both solenoid valves and air-piloted valves.

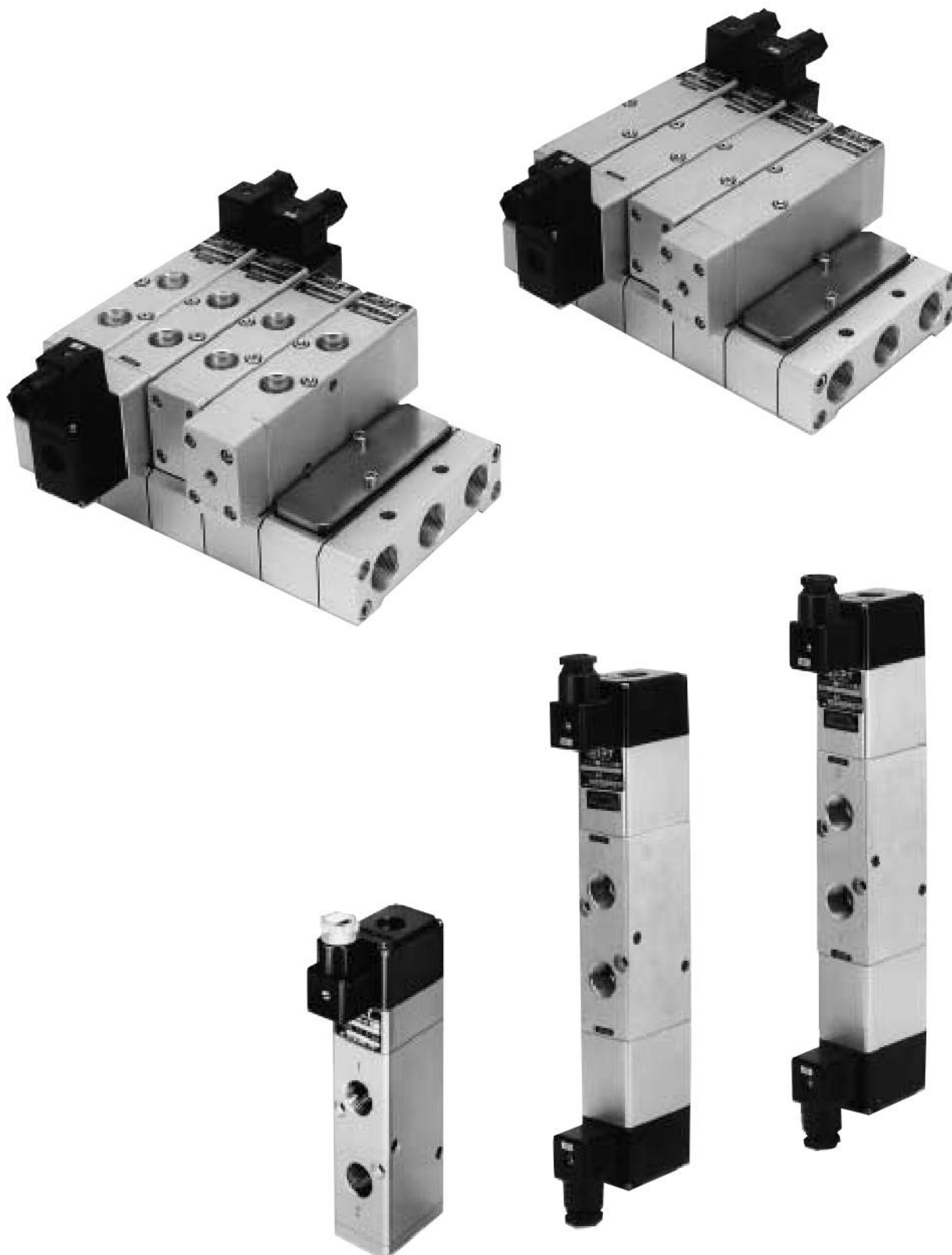

# Solenoid Valve

- Product range includes pilot type 2-position and 3-position valves.
- The 3-position valve selections include closed center or exhaust center.
- The 2-position and 3-position valves as single units can be mounted together on the 600-series manifold.
- The AC solenoid uses a shading coil to protect against solenoid burning or humming.







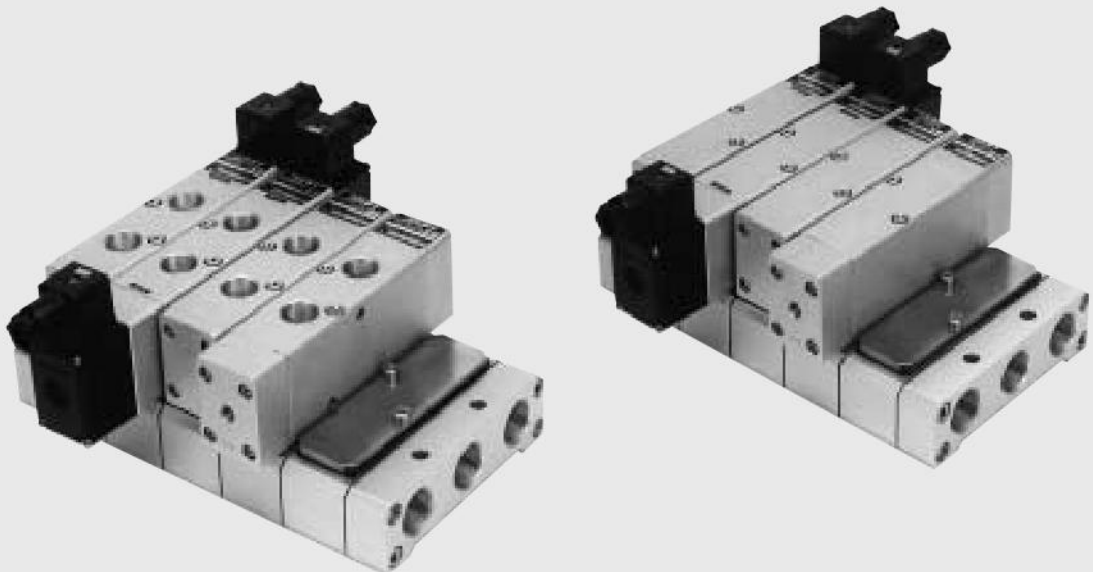

# Manifold

- The direct piping type single valve is a low-cost type that can itself be mounted on a manifold (F type).
- The product range also includes a type that enables piping from the bottom surface of the manifold. (A type).
- The combination mounting of solenoid valves and air-piloted valves is possible.

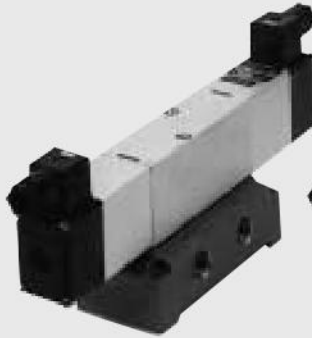
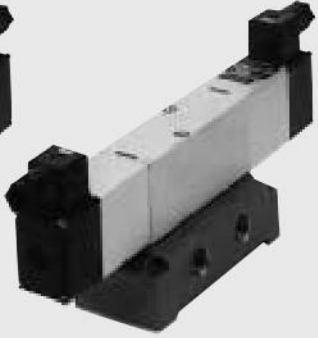

Single unit

		5-port			
		2-position		3-position	
Direct piping	Single solenoid	Double solenoid	Closed center	Exhaust center	
					
	<b>600-4E1</b>	<b>600-4E2</b>	<b>603-4E2</b>	<b>603-4E2-13</b>	
Sub-base piping	Single solenoid	Double solenoid	Closed center	Exhaust center	
					
	<b>A600-4E1-25</b>	<b>A600-4E2-25</b>	<b>A603-4E2-25</b>	<b>A603-4E2-13-25</b>	

## Manifold

Manifold for mounting 5-port valves

LM□F—F type (1(P), 3(R2), 5(R1)) manifold

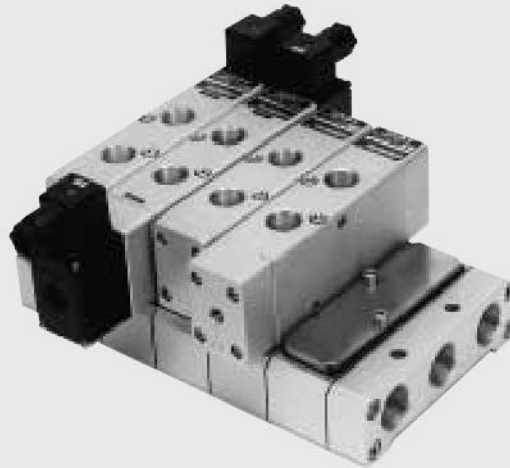

LM□A—A type (bottom piping) manifold

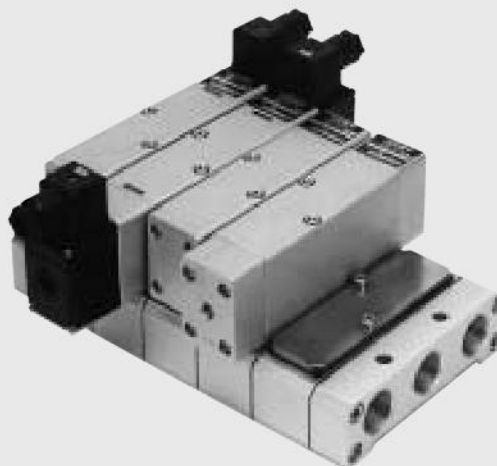

# SOLENOID VALVES

## 600 SERIES

### Basic Models and Valve Functions

Item	Basic model	600-4E1	600-4E2	603-4E2
		A600-4E1	A600-4E2	A603-4E2
Number of positions		2		3
Number of ports		5		
Valve function		Single solenoid	Double solenoid	Double solenoid

Remark: For optional specifications and order codes, see p.775~776.

### Specifications

Item	Basic model	600-4E1	600-4E2	603-4E2
		A600-4E1	A600-4E2	A603-4E2
Media		Air		
Operation type		Internal pilot type		
Effective area [Cv]	mm <sup>2</sup>	60 [3.33]		
Port size <sup>Note</sup>		Rc1/2 or Rc3/8		
Lubrication		Not required		
Operating pressure range	Mpa[kgf/cm <sup>2</sup> ] [psi.]	0.15~0.9 [1.5~9.2] [22~131]		0.2~0.9 [2.0~9.2] [29~131]
Proof pressure	Mpa[kgf/cm <sup>2</sup> ] [psi.]	1.35 [13.8] [196]		
Response time	ms	DC24V	25 or below	35 or below
ON/OFF		AC100V, AC200V	25 or below	35 or below
Maximum operating frequency	Hz	2		1
Minimum time to energize for self holding	ms	—	50	
Operating temperature range (atmosphere and media)	°C [°F]	5~50 [41~122]		
Shock resistance	m/s <sup>2</sup> [G]	980.7[100.0]		
Mounting direction		Any		

Note: For details, see the port size.

### Solenoid Specifications

Item	Rated voltage	DC24V	AC100V		AC200V	
	Type		—	AC solenoid (Shading coil type)		
Operating voltage range	V	21.6~26.4 (24±10%)	90~130 (100 <sup>+30</sup> / <sub>-10</sub> %)		180~260 (200 <sup>+30</sup> / <sub>-10</sub> %)	
Current (when rated voltage is applied)	Frequency Hz	—	50	60	50	60
	Starting mA(r.m.s)	—	106	94	51	46
	Energizing <sup>Note</sup> mA(r.m.s)	240 [252 (6.0W)]	55 [57]	44 [44]	27 [26]	22 [21]
Insulation resistance	MΩ	Over 10				
Wiring type		With terminal				
Lead wire color		Red	Yellow		White	
Color of LED indicator		Red	Yellow		Green	
Surge suppression		—	Solenoids with LED indicators employ a surge absorber			

Note: Figures in brackets [ ] are for solenoids with LED indicator.

### Manifold Connection Port Size

Manifold model	Port	Location of piping connection	Port size
LM□F	1(P), 3(R2), 5(R1)	Manifold	Rc3/4
	4(A), 2(B)	Valve	Rc1/2, Rc3/8
LM□A	1(P), 3(R2), 5(R1)	Manifold	Rc3/4
	4(A), 2(B)	Manifold	Rc1/2, Rc3/8

## Solenoid Valve Mass

g [oz.]

Basic model	Mass
600-4E1	900 [31.75]
600-4E2	1140 [40.21]
603-4E2	1400 [49.38]
A600-4E1	900 [31.75]
A600-4E2	1140 [40.21]
A603-4E2	1400 [49.38]
600-4A	700 [24.69]
600-4A2	780 [27.51]
A600-4A	700 [24.69]
A600-4A2	780 [27.51]

## Manifold Mass

g [oz.]

Manifold model	Mass calculation of each unit (n=number of units)	Block-off plate
LM□F	$(330 \times n) + 640$ [(11.64 × n) + 22.57]	175 [6.17]
LM□A	$(330 \times n) + 640$ [(11.64 × n) + 22.57]	175 [6.17]

## Flow Rate

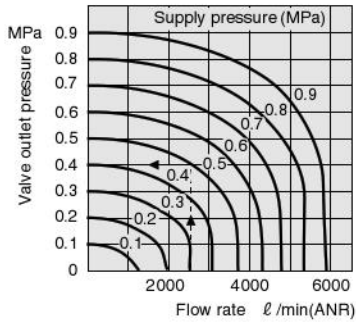

1MPa=145psi. 1 l /min.=0.0353ft.<sup>3</sup>/min.

### How to read the graph

When the supply pressure is 0.5MPa [73psi.] and the flow rate is 2550 l /min [90.0ft.<sup>3</sup>/min.] (ANR), the valve outlet pressure becomes 0.4 MPa [58psi.].

# Solenoid Valve, Air-piloted Valve Order Codes

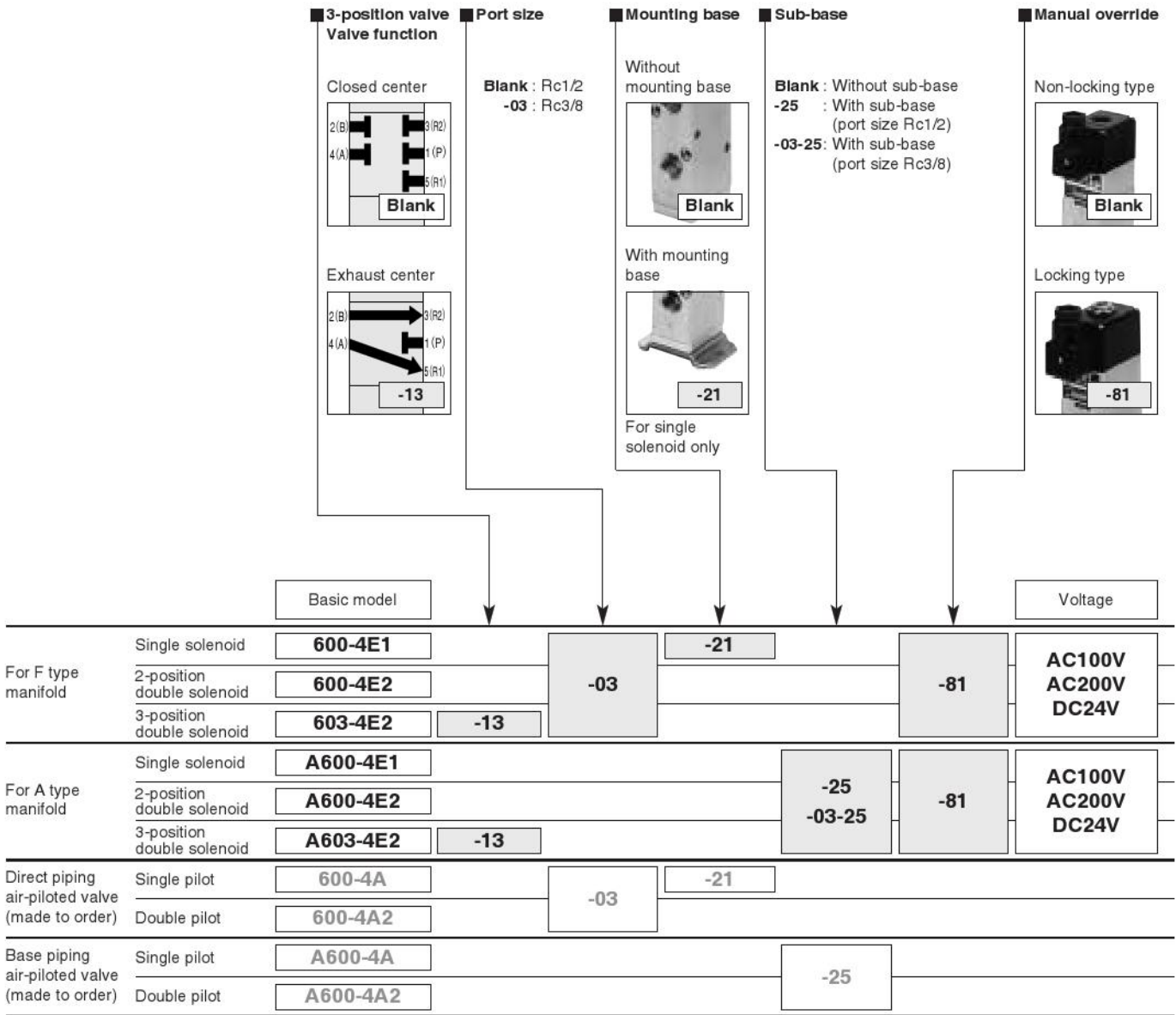

## Options

Mounting base



- For direct piping
- Not available for double solenoid

Sub-base



- -25 (Port size Rc1/2)
- -03-25 (Port size Rc3/8)

Manual override



- Locking type

# Manifold Order Codes

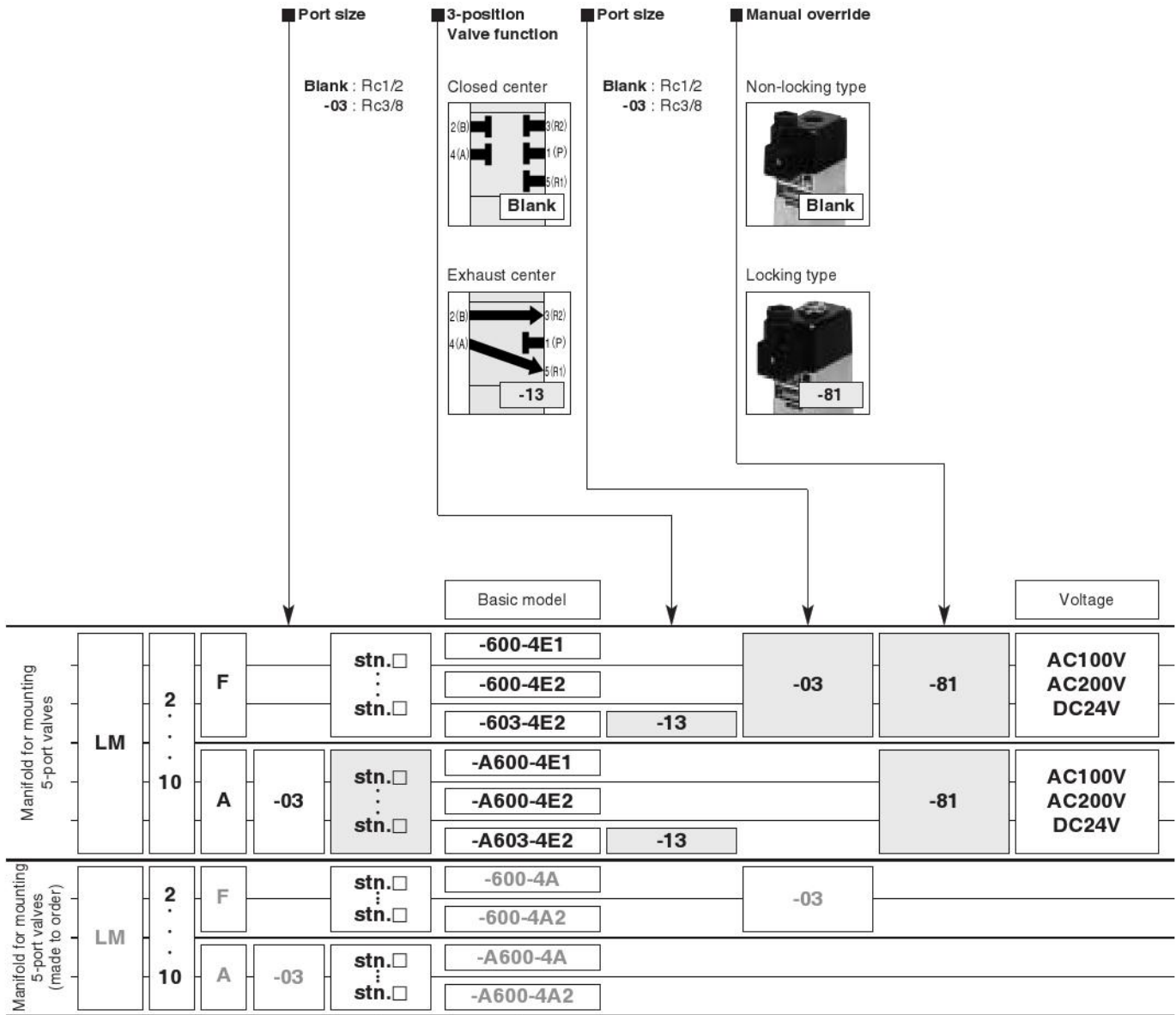

SOLENOID VALVES 600 SERIES

- Valve mounting location from the left-hand side when facing the 4(A), 2(B) ports.
- Specify the valve model for each station.
- Enter **-BP** when closing a station with a block-off plate without mounting a valve.

## Made to Order

Air-piloted valve  
600 series

Grommet type  
with LED indicator

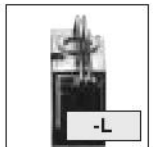

- 5-port, 2-position
- Single pilot
- Double pilot

5-port, 2-position

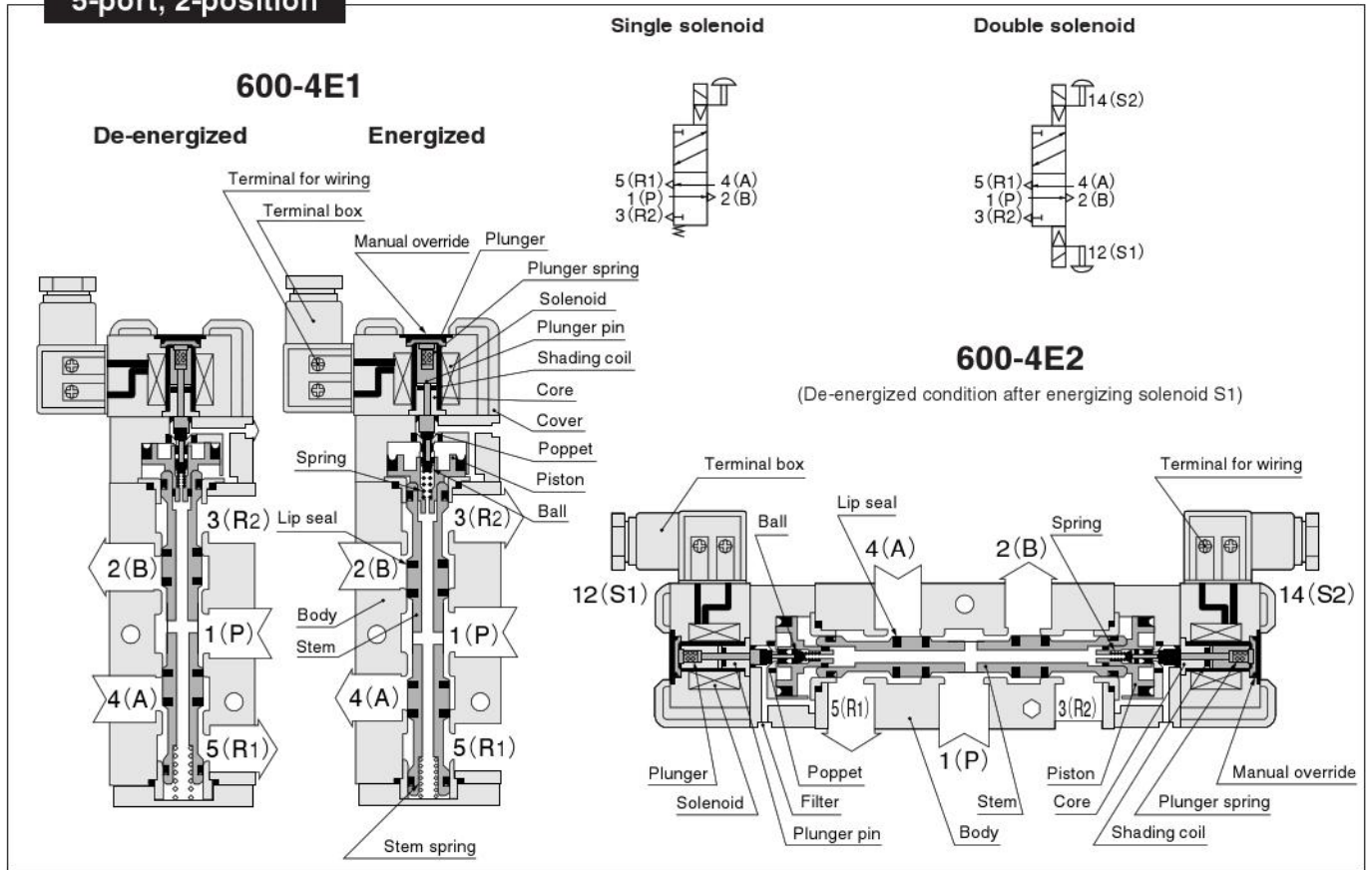

5-port, 3-position

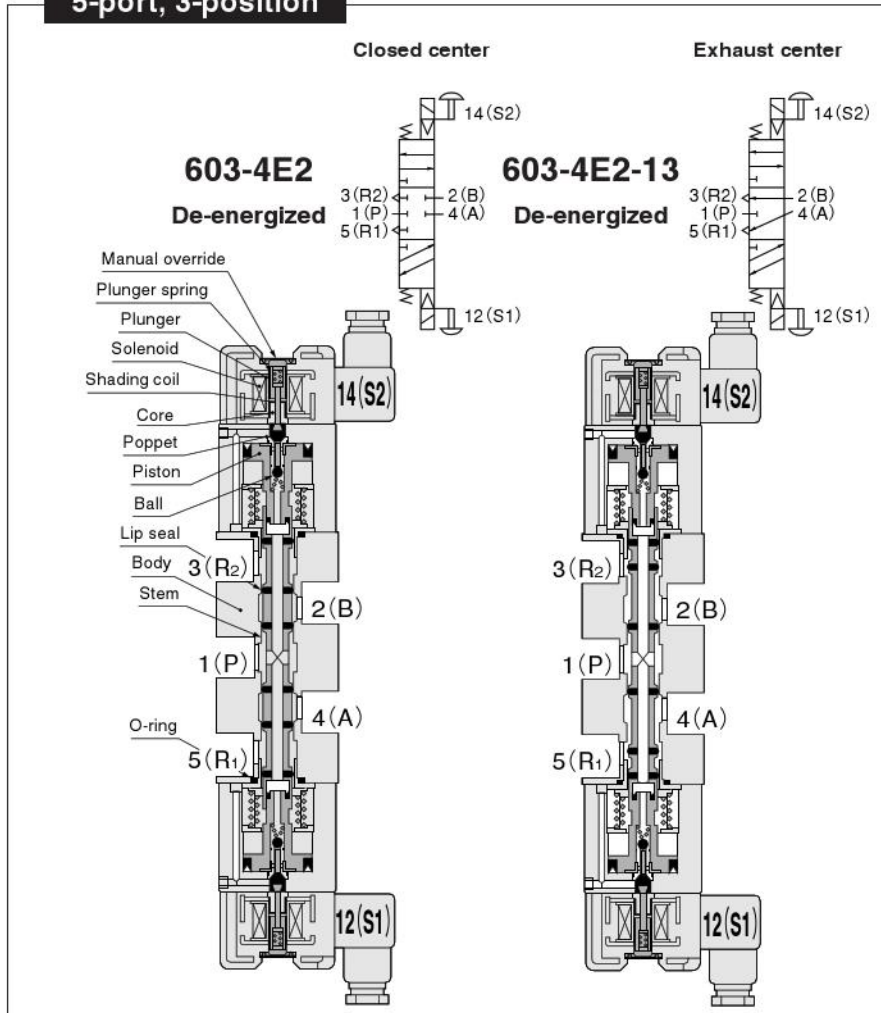

Major Parts and Materials

	Parts	Materials
Valve	Body	Aluminum alloy (anodized)
	Stem	
	Plunger	Stainless steel
	Plunger pin	
	Stem spring	Synthetic rubber
	Lip seal	
	Seal	
	O-ring	Mild steel (zinc plated)
	Base	
Manifold	Body	Aluminum alloy (anodized)
	Block-off plate	Mild steel (zinc plated)
	Seal	Synthetic rubber

# Dimensions of Solenoid Valve (mm)

## 600-4E1

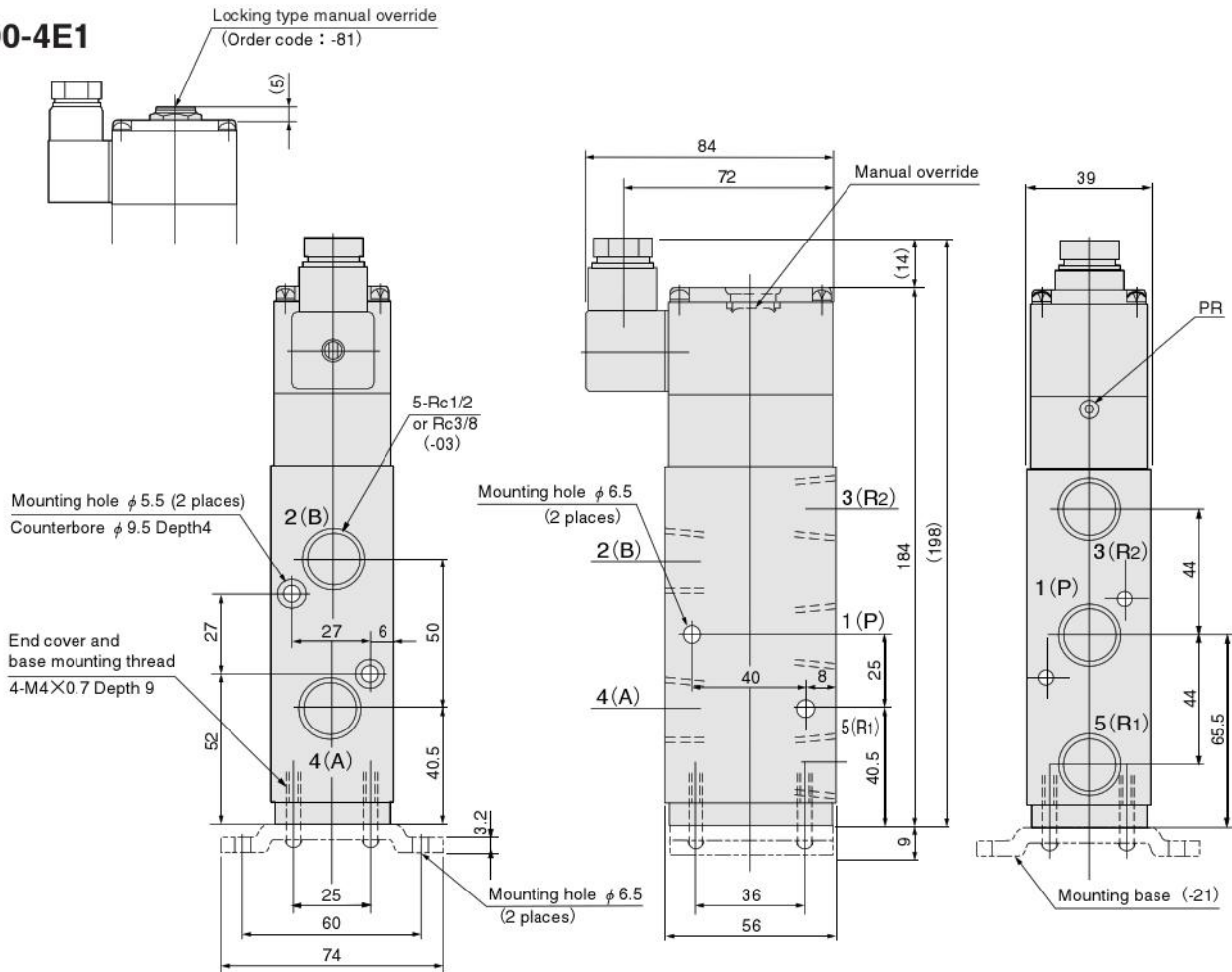

## 600-4E2

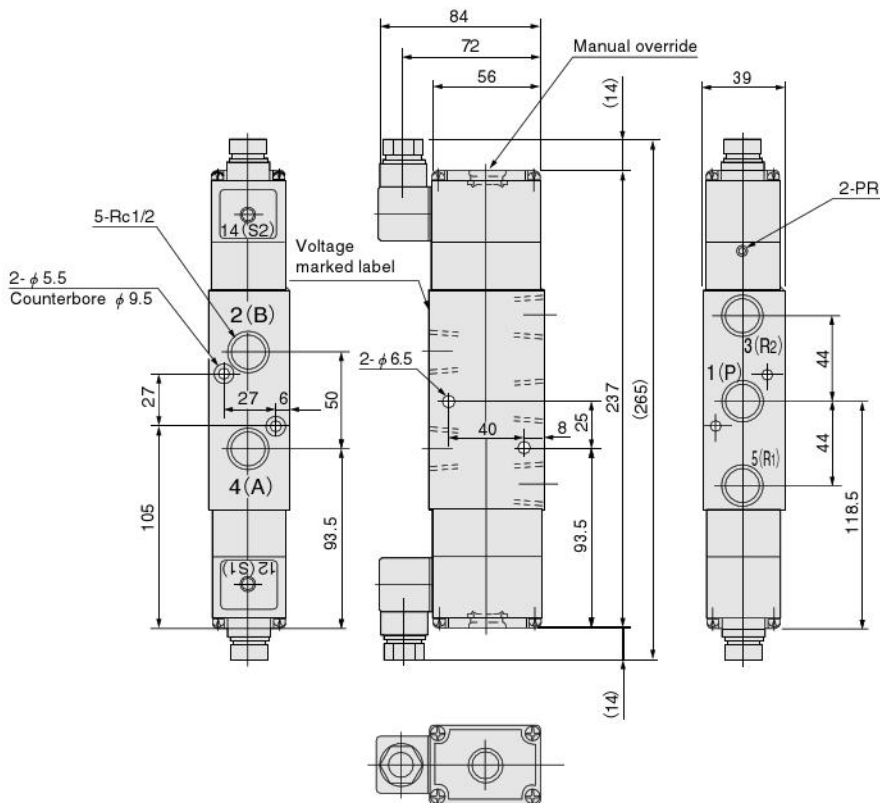

# Dimensions of Solenoid Valve (mm)

603-4E2 Closed center

603-4E2-13 Exhaust center

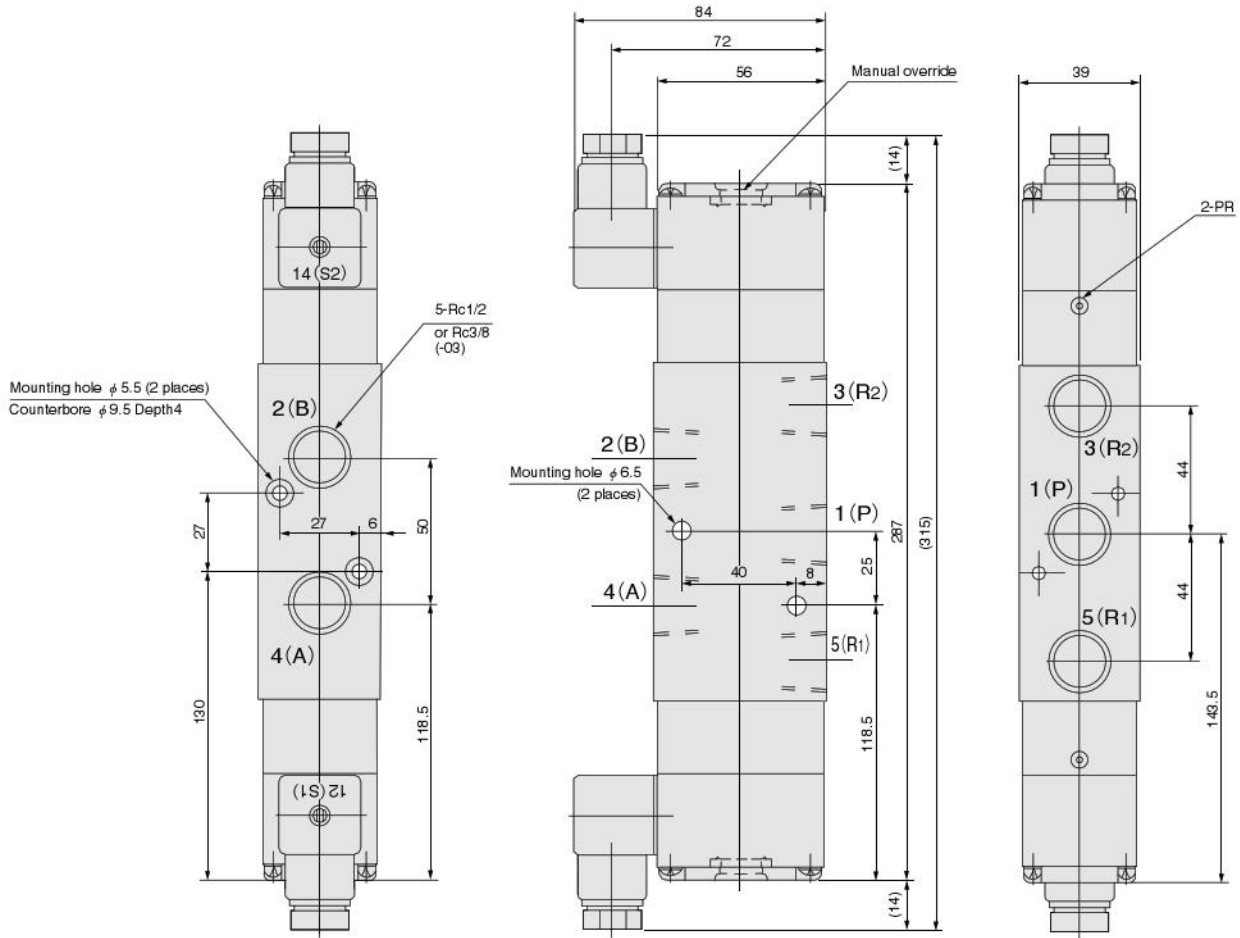

## Dimensions of mounting sub-base for all port piping

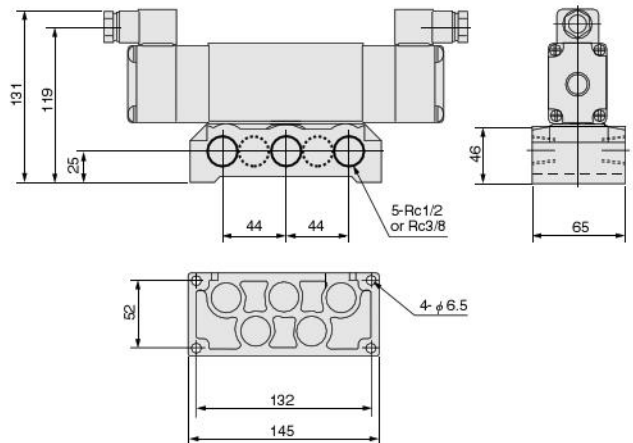

# Dimensions of Manifold (mm)

## F type

### Unit dimensions

Code Number of units	P	L
LM2F	107	131
LM3F	147	171
LM4F	187	211
LM5F	227	251
LM6F	267	291
LM7F	307	331
LM8F	347	371
LM9F	387	411
LM10F	427	451

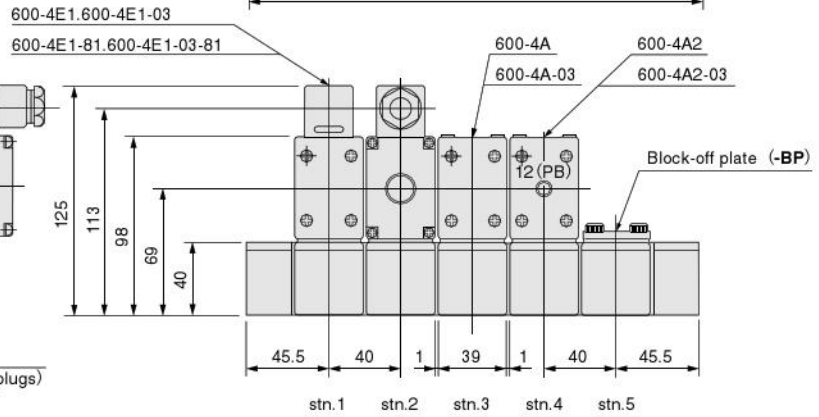
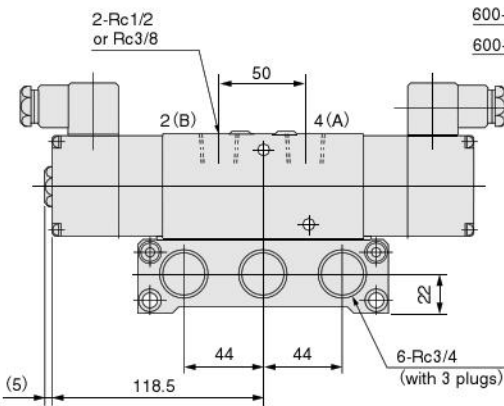
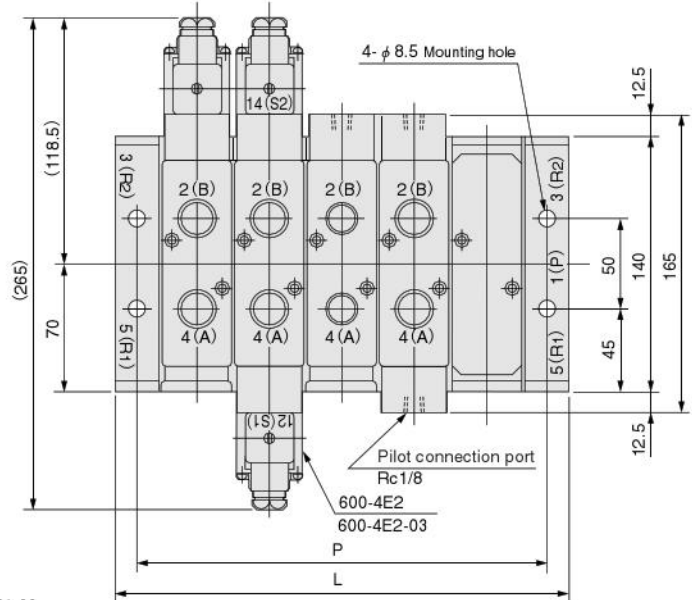

## A type

### Unit dimensions

Code Number of units	P	L
LM2A	107	131
LM3A	147	171
LM4A	187	211
LM5A	227	251
LM6A	267	291
LM7A	307	331
LM8A	347	371
LM9A	387	411
LM10A	427	451

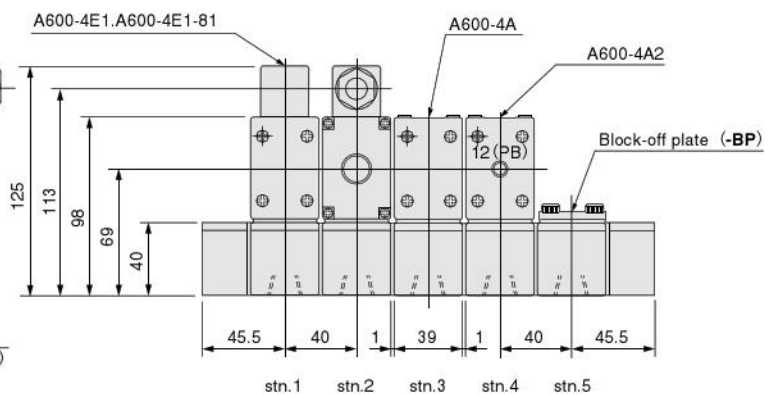
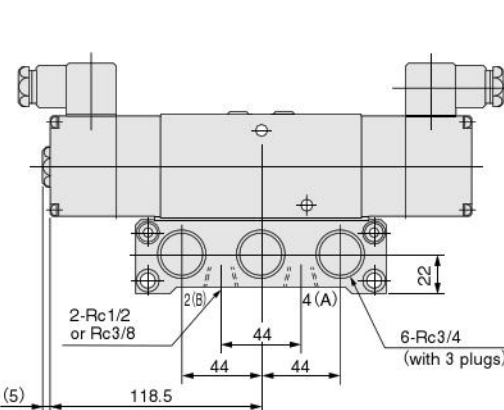
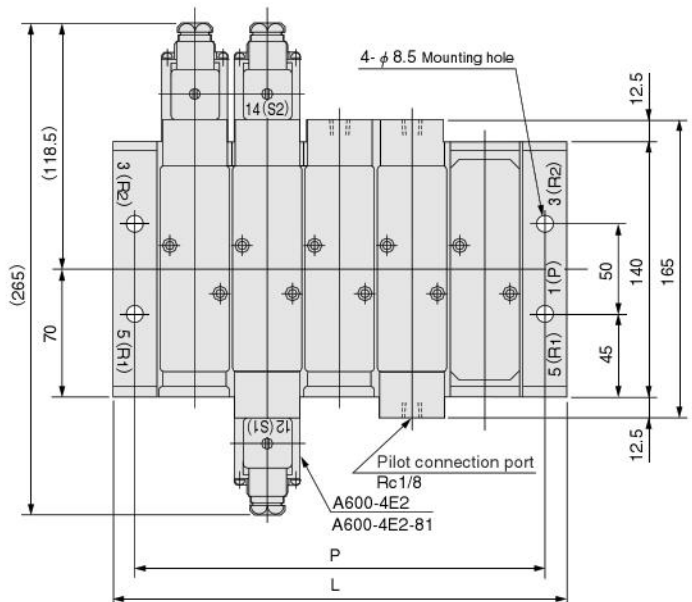

# Made to Order

## Air-piloted valve 600 series

●The optimum air-piloted valves for master valves or pilot valves for all-pneumatic control.



### Basic Models and Valve Functions

Item	Basic model	600-4A	600-4A2
		Direct piping, F type manifold	
	Sub-base piping, A type manifold	A600-4A	A600-4A2
Number of positions		2 positions	
Number of ports		5 ports	
Valve function		Single pilot	Double pilot

Remarks: For optional specifications and order codes, see p.775~776.

### Specifications

Item	Basic model	For direct piping, F type manifold		For sub-base piping, A type manifold	
		Single pilot	Double pilot	Single pilot	Double pilot
Media		Air			
Effective area [Cv] <sup>Note 1</sup> mm <sup>2</sup>		60 [3.33]		60 [3.33]	
Port size <sup>Note 2</sup>	Main	Rc1/2 or Rc3/8			
	Pilot	Rc1/8			
Lubrication		Not required			
Operating pressure range MPa[kgf/cm <sup>2</sup> ] [psi.]	Main	0~0.9 [0~9.2] [0~131]			
	Pilot	See the table "Minimum Pilot Pressure"			
Proof pressure MPa[kgf/cm <sup>2</sup> ]		1.35 [13.8] [196]			
Operating temperature range (atmosphere and media) °C [°F]		5~50 [41~122]			
Shock resistance m/s <sup>2</sup> [G]	Lateral direction	980.7{100.0}	980.7{100.0}	980.7{100.0}	
	Axial direction	980.7{100.0}	294.2{30.0} <sup>Note 3</sup>	980.7{100.0}	294.2{30.0} <sup>Note 3</sup>
Mounting direction		Any			

Notes: 1. For details, see the effective area.  
 2. For details, see the port size.  
 3. Value when pilot is off.  
 When pilot is on, the value is 980.7{100.0}m/s<sup>2</sup> [G].

### Effective Area [Cv]

Basic model	Standard (single valve)
600-4A	60
600-4A2	[3.33]
A600-4A	60
A600-4A2	[3.33]

### Manifold Connection Port Size

Manifold model	Port	Location of piping connection	Port size
LM□F	1(P), 3(R2), 5(R1)	Manifold	Rc3/4
	4(A), 2(B)	Valve	Rc1/2, Rc3/8
LM□A	1(P), 3(R2), 5(R1)	Manifold	Rc3/4
	4(A), 2(B)	Manifold	Rc1/2, Rc3/8

### Air-piloted Valve Mass

Basic model	Mass
600-4A	700 [24.69]
600-4A2	780 [27.51]
A600-4A	750 [26.46] (1570 [55.38])
A600-4A2	830 [29.28] (1650 [58.20])

Remark: Figures in parentheses ( ) are the mass with sub-base: -25.

### Manifold Mass

Manifold model	Mass calculation of each unit (n=Number of units)	Block-off plate
LM□F	(330×n)+640 [(11.64×n)+22.57]	175 [6.17]
LM□A	(330×n)+640 [(11.64×n)+22.57]	175 [6.17]

### Minimum Pilot Pressure

Model	Main pressure MPa {kgf/cm <sup>2</sup> } [psi.]					
	0.02 [0.2] [3]	0.1 [1.0] [15]	0.3 [3.1] [44]	0.5 [5.1] [73]	0.7 [7.1] [102]	0.9 [9.2] [131]
600-4A	0.12 [1.2] [17]	0.15 [1.5] [22]	0.2 [2.0] [29]	0.25 [2.5] [36]	0.33 [3.4] [48]	0.4 [4.1] [58]
600-4A2	0.1 [1.0] [15]		0.12 [1.2] [17]		0.15 [1.5] [22]	

### Time Required for Switching

Model	Operation	Pilot line length ℓ m [ft.]				
		2 [6.6]	6 [19.7]	10 [32.8]	20 [65.6]	50 [164]
600-4A	ON	0.06	0.12	0.18	0.36	1.20
	OFF	0.09	0.20	0.30	0.62	2.40
600-4A2	ON					
	OFF	0.06	0.12	0.20	0.40	1.40

Measurement conditions: Air pressure (both main and pilot)=0.5MPa [73psi.]  
 Tube inner diameter=4mm [0.16in.]

### LED indicator

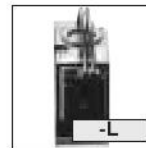

The LED indicator for confirmation of operation offers a clean monoblock look with a compact cover.

●When ordering, enter -L before the voltage specification.

### AC100V AC200V

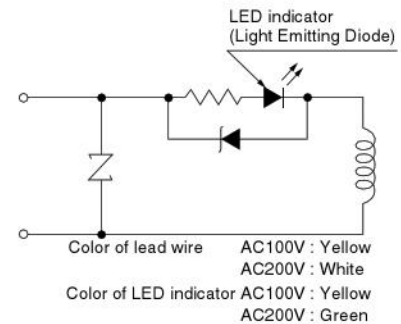

### DC24V

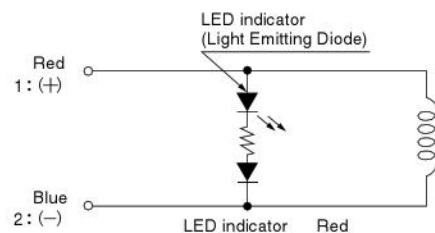

## Flow Rate

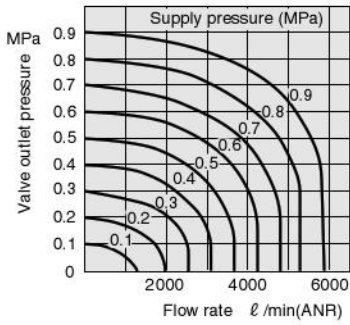

1MPa=145psi. 1 l/min.=0.0353ft<sup>3</sup>/min.

## Operating Principles and Symbols

### 5-port, 2-position

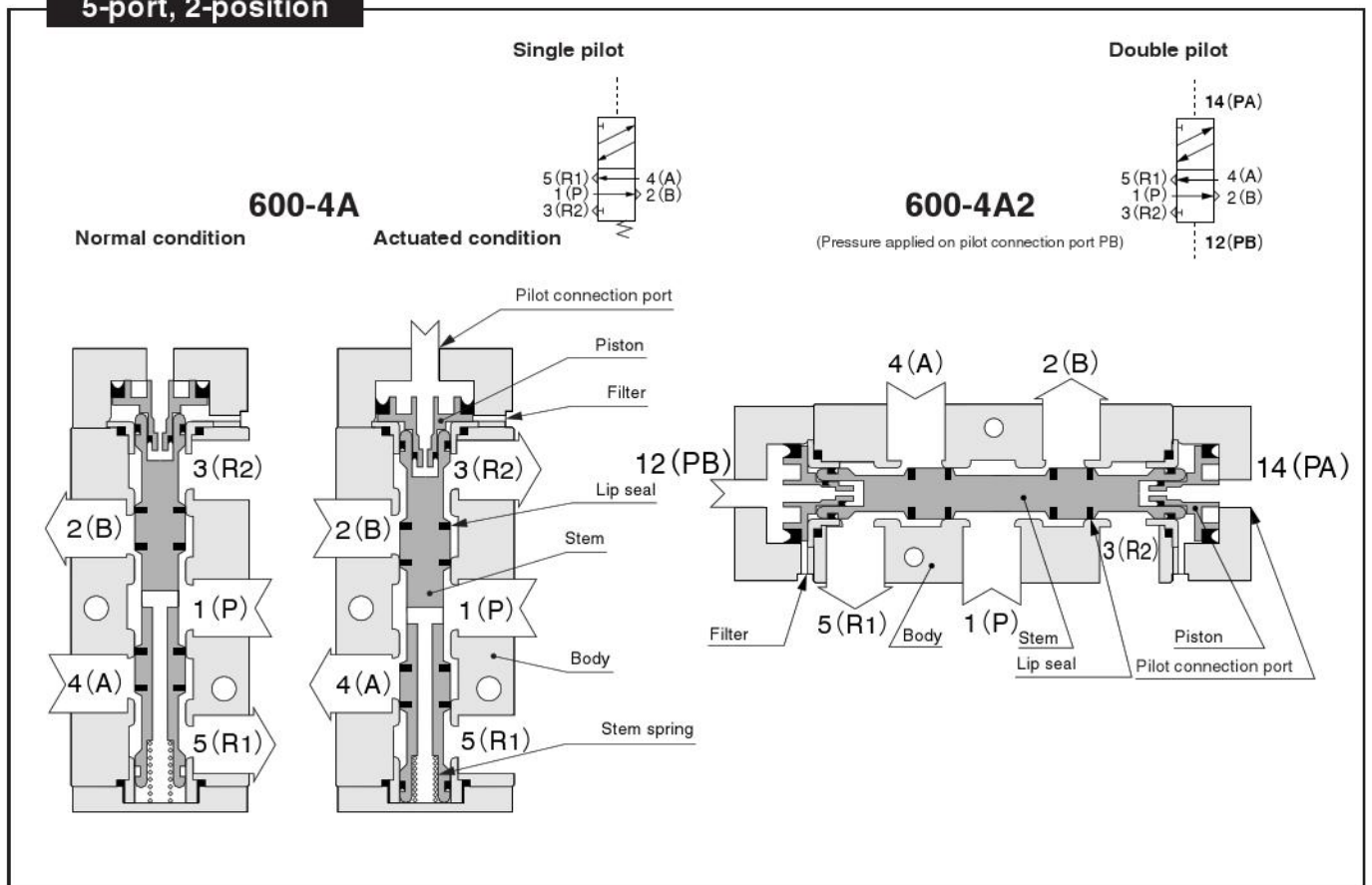

SOLENOID VALVES 600 SERIES

## Major Parts and Materials

Parts	Materials
Body	Aluminum alloy (anodized)
Stem	
Stem spring	Stainless steel
Lip seal	Synthetic rubber
Seal	
O-ring	
Base	Mild steel (zinc plated)

Dimensions of Air-piloted Valve (mm)

600-4A

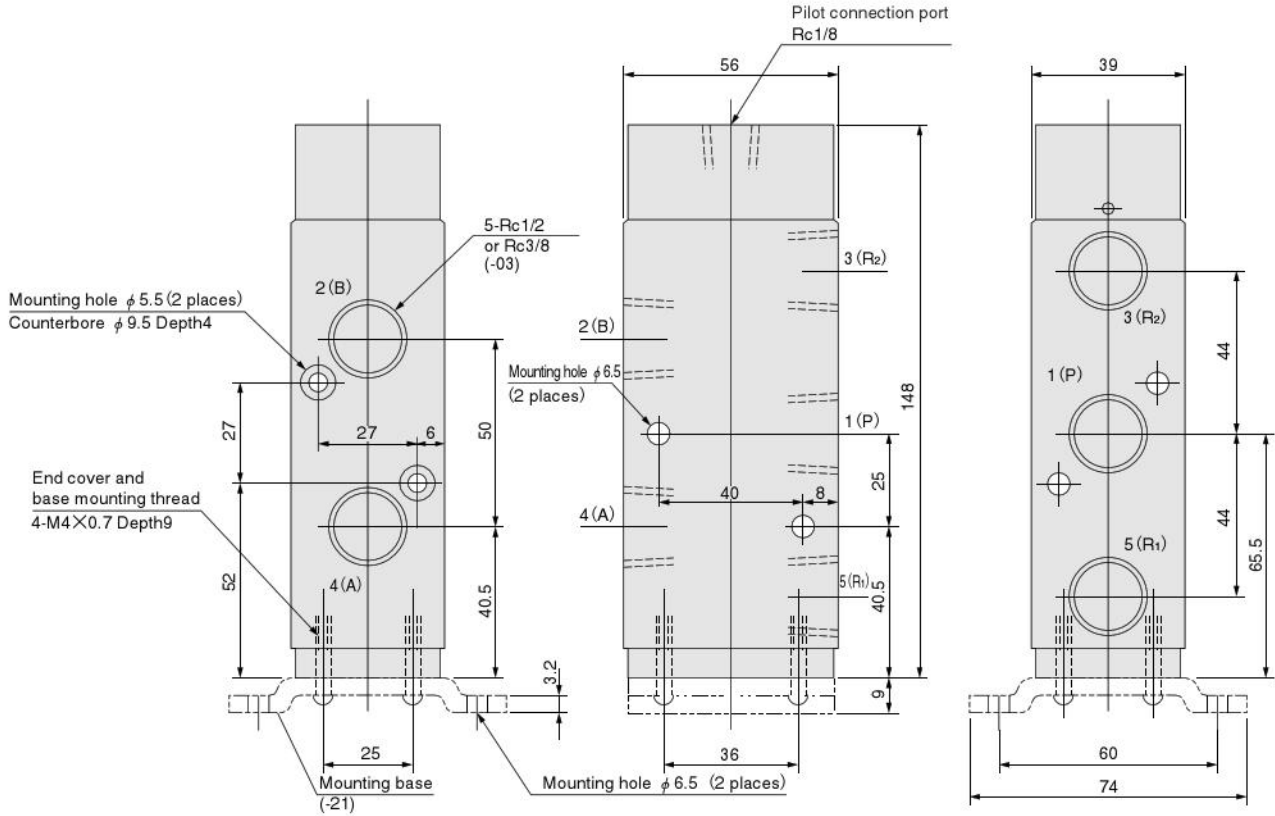

600-4A2

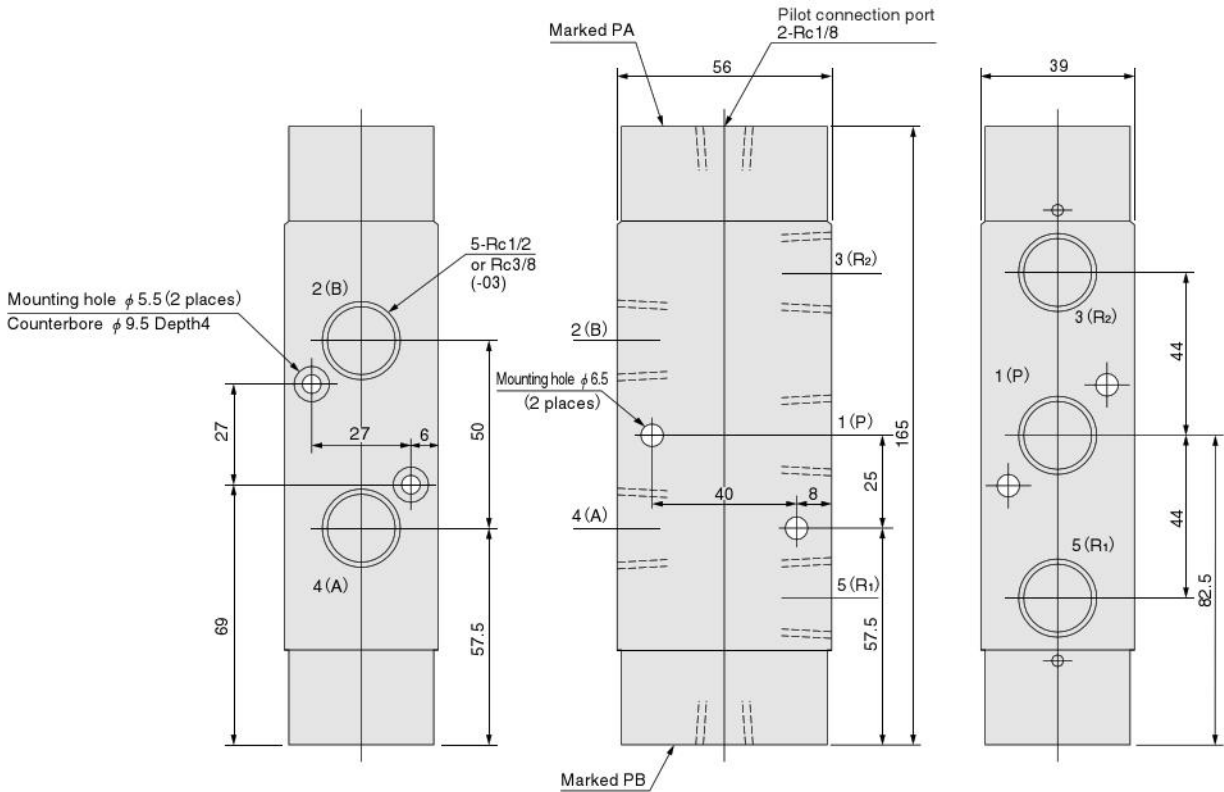

# Handling Instructions and Precautions



## Manual override

### Non-locking type

To operate the manual override, press it all the way down. For the single solenoid, the valve works the same as when in the energized state as long as the manual override is pushed down, and returns to the normal position upon release.

For the double solenoid, pressing the manual override on the 12(S1) side switches the 12(S1) to enter the energized position, and the unit remains in that state even after the manual override is released. To return it to the normal position, operate the manual override on the 14(S2) side. This is the same for the solenoid 14(S2).

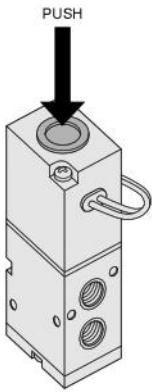

※ Illustration shows the 200 series.

**Caution:** In the pilot type valve, the manual override cannot switch the main valve without air supplied from the 1(P) port.

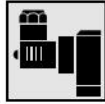

## Terminal type connector

### Wiring instructions

- Remove the terminal cover mounting screw (2), pull out and lift off the terminal cover (3) from the solenoid body (1).
- Insert the cable from the wiring port on the terminal cover (3), and connect the cable to the terminal (4) of the solenoid body (1).
- While pulling the cable, place the terminal cover (3) on the solenoid body (1), and use the terminal cover mounting screw (2) to secure the terminal cover on the solenoid body (1) in place.

