



New-generation Filter Regulator

FRZ Series

NPT thread specifications



Flexible installation

Water removal function eliminated for more flexible installation

Improved operability

Improved knob operability and simple bowl installation and removal



New-generation Filter Regulator

FRZ Series

Excellent for air lines with water and fluids already removed.

Specialized **30 series** for standalone application



1.378



Regulator
RZ30



Filter regulator
FRZ30

The **40 and 50 series** can be used in combinations



1.575



Regulator
RZ40



Filter regulator
FRZ40

1.969



Regulator
RZ50



Filter regulator
FRZ50

Down sizing

Improved flow rate characteristics allow a smaller configuration (close side-by-side spacing is possible).

Flexible installation

Water removal function is eliminated for more flexible installation.

Improved operability and maintainability

Improved knob operability and simple bowl installation and removal.

Pressure gauge, pressure switch

Supports □1.181 in. integrated pressure gauges, other pressure gauges, and pressure switches.

Supports a wide variety of environments

Ozone resistance specifications and NCU specifications (copper free)^{Note} are standard.

Note: Excluding pressure switch and pressure gauge options.



CAUTION

Read the safety precautions on page 4 before using this product.

Compact design

Improved flow rate characteristics enable a smaller configuration.

*Compared to the R600 and RZ50 Koganei Regulator.

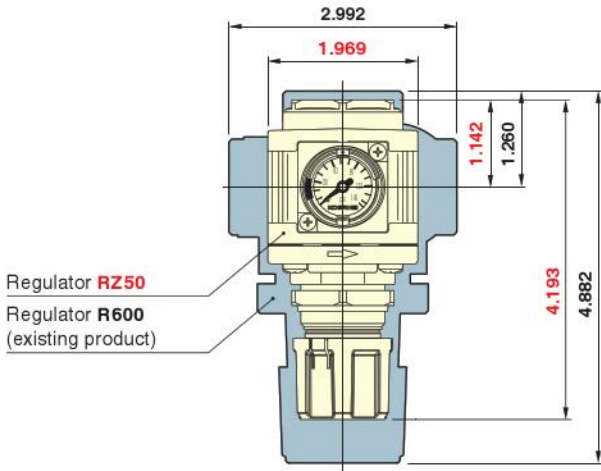

More flexible installation

Water and impurity removal functions have been eliminated for more flexible installation. Bowl can be mounted on the top or the sides.

Filter bowl section



Filter regulator FRZ40

Improved knob operability

- The knob is sized and shaped to turn smoothly with a light touch for easy operation. Also, the knob lock precision has been improved to reduce changes in pressure settings when the knob is locked.
- The status of the lock release can be checked with the yellow caution ring.



1.181 in. series integrated pressure gauge

- 1.181 in. integrated pressure gauge is compact with almost nothing sticking out. Visibility is also improved with an easy to see 270° swing angle display.

270° swing angle



- Flexible change of the pressure setting range (the green part) is possible. Freely changeable upper and lower setting limits eliminate the need to remove the front cover (the transparent plastic part) and to use special tools.

Pressure setting range



Pressure setting range after change



Protrusions (two locations)

The setting pressure range display can be changed as desired by rotating the protrusions (two locations) clockwise or counter clockwise.

Improved maintainability

- The bowl can be removed and attached in two easy steps. The filter element can be replaced easily even in small narrow spaces.
- The filter element is a non-woven-fabric. Improved porosity and enlarged circumference area extend its operating life.



Element

Bowl

*Other pressure gauges and pressure switches are available.

See the next page for details.

Pressure gauge, pressure switch

Can select various types of pressure gauges and pressure switches other than the □1.181 in. integrated pressure gauge.

Order code G1-40-F11

φ 1.575 in. pressure gauge
(145 psi specification)

G3-40-F11

φ 1.575 in. pressure gauge
(43.5 psi specification)

G1S-40-F11

φ 1.575 in. stainless steel
Bourdon tube pressure gauge
(145 psi specification)

G3S-40-F11

φ 1.575 in. stainless steel
Bourdon tube pressure gauge
(43.5 psi specification)



Digital pressure switch
GS620-3W
(145 psi specifications)

GS1-50-F11-□-□

Pressure gauge with
built-in switches
(145 psi specification)

Pressure switch module

The pressure in the air line is easy to detect with the connecting bracket and integrated compact pressure switch. The set pressure can be adjusted from the front.

Note: Cannot be installed with the 30 series body size.



Module adapter

These devices are used to connect devices for the 40 series and 50 series body sizes.

Note: Cannot be installed with the 30 series body size.



F module
(for connections)



D module
(for connections, with bracket)



T module
(for branches)



DT module
(for branches, with bracket)



S adapter
(for changing pipe size)



DS adapter
(for changing pipe size, with bracket)



Module bracket
(for module adapters)



Coupling plate
(replacement parts)

Residual pressure exhaust valve

The pressure in the air line can be exhausted through a 3-port valve. Better safety through a lock mechanism (with a lock hole) while exhausting residual pressure. Also, an easy to see red color is used for better visibility of the operating Knob.

Note: Cannot be installed with the 30 series body size.



Air being supplied Air being exhausted

Bracket

The brackets can be used with all size filter regulators and regulators.







Panel mounting

A φ 1.122 in. panel mounting hole can be used for all sizes of the filter regulators and regulators.

Before selecting and using the products, please read all safety precautions carefully to ensure proper product use. The safety precautions described below are to help you use the product safely and correctly, and to prevent injury or damage to you, other people, and assets.

Always adhere to the following safety regulations: ISO4414 (Pneumatic fluid power - General rules and safety requirements for systems and their components) and JIS B 8370 (General rules relating to pneumatic systems).

The directions are ranked according to degree of potential danger or damage: "DANGER", "WARNING", "CAUTION", and "ATTENTION".

 DANGER	Indicates situations that can be clearly predicted as dangerous. Failure to avoid the situation creates the risk of death or serious injury. It could also result in damage or destruction of assets.
 WARNING	Indicates situations that, while not immediately dangerous, could become dangerous. Failure to avoid the situation creates the risk of death or serious injury. It could also result in damage or destruction of assets.
 CAUTION	Indicates situations that, while not immediately dangerous, could become dangerous. Failure to avoid the situation creates the risk of minor or semi-serious injury. It could also result in damage or destruction of assets.
 ATTENTION	While there is little chance of injury, this content refers to points that should be observed for appropriate use of the product.

- **This product was designed and manufactured for use in general industrial machinery.**
- When selecting and handling equipment, the system designer or another person with sufficient knowledge and experience should always read the safety precautions, catalog, instruction manual and other literature before commencing operation. Improper handling is dangerous.
- After reading the instruction manual, catalog, and other documentation, always store them in a location that allows easy availability for reference to users of this product.
- Whenever transferring or lending the product to another person, always attach the catalog, instruction manual, and other information to the product where they are easily visible in order to ensure that the new user can use the product safely and properly.
- The danger, warning and caution items listed under these safety precautions do not cover all possible contingencies. Read the catalog and instruction manual carefully, and always keep safety first.

 DANGER

- Do not use the product for the purposes listed below:
 1. Medical equipment related to maintenance or management of human lives or bodies.
 2. Machines or equipment designed for the purpose of moving or transporting people.
 3. Critical safety components in mechanical devices.
 This product has not been planned or designed for purposes that require high levels of safety. Using the product in any of the ways described above creates the risk of loss of human life.
- Do not use the product in locations with or near dangerous substances such as flammable or ignitable substances. This product is not explosion-proof. Doing so creates the risk of ignition and fire.
- When mounting the product and workpiece, always make sure they are firmly supported and secured in place. Falling, dropping, or abnormal operation of the product creates the risk of personal injury.
- People using a pacemaker or other similar medical devices should keep a distance of at least 3.28 ft away from the product. There is a strong magnet inside the product and the magnetic field of this magnet may cause a pacemaker to malfunction.
- Never attempt to modify the product. Doing so can cause malfunctions and create the risk of personal injury, electric shock, fire, etc.
- Never attempt inappropriate disassembly, assembly or repair of the product relating to basic construction, or to its performance or to functions. Doing so creates the risk of injury, electric shock, fire, etc.
- Do not splash water on the product. Spraying it with water, washing it, or using it under water could result in malfunction of the product leading to injury, electric shocks, fire, etc.
- While the product is in operation, avoid touching it with your hands or otherwise approaching too close. Also, do not attempt to make any adjustments to internal or attached mechanisms, or to perform any type of adjustment (disconnecting cable connectors, adjusting pressure switches, disconnecting tubes or sealed plugs, adjusting the product's mounting position, etc.) while the product is in operation. Falling, dropping, or abnormal operation of the product creates the risk of personal injury.

 WARNING

- Because Koganei products are designed for use under a wide variety of conditions, decisions concerning conformance with a particular system should be made upon the careful evaluation by the person in charge of system design.

- Assurances concerning expected system performance and safety are the responsibility of the designer who decides system conformity. Be sure to use the latest catalogs and technical materials to study and evaluate specification details, to consider the possibility of machine breakdown, and to configure a system that ensures fail-safe safety and reliability.
- Do not use the product in excess of its specification range. Doing so creates the risk of product breakdown, loss of function, or damage. It could also drastically reduce operating life.
 - Before supplying air or electricity to the device and before starting operation, always conduct a safety check of the area of machine operation. Unintentional supply of air or electricity creates the risk of injury due to contact with moving parts.
 - Do not touch terminals, switches, or other parts, while power is turned on. Doing so creates the risk of electric shock and malfunction.
 - Do not allow the product to be thrown into fire. Doing so creates the risk of explosion resulting in the release of toxic gases.
 - Do not sit on the product, place your foot on it, or place other objects on it. Doing so creates the risk of injury due to tripping or the product tipping over, resulting in product damage and abnormal, erratic, or runaway operation.
 - Before conducting maintenance, inspection, repair, replacement, or any other similar procedure, always completely cut off the air supply and confirm that residual pressure inside the product or in piping connected to the product is atmospheric pressure. In particular, be aware that residual air will still be in the compressor or storage tank. The actuator may move abruptly if residual air pressure remains inside the piping, causing injury.
 - Use safety circuits or design a system that prevents damage to machinery or injury to personnel when the machine is shut down due to an emergency stop or electrical power failure.
 - Before performing any kind of wiring work, be sure to turn off power. Failure to do so creates the risk of electric shock.
 - Do not allow lead wires and other cords to become damaged. Allowing a cord to become cut, bent excessively, pulled, rolled up, placed under heavy objects, or squeezed between two objects creates the risk of current leaks or defective continuity that can lead to fire, electric shock, or abnormal operation.
 - Do not connect or disconnect connectors while power is turned on. Also, never apply unnecessary force to connectors. Doing so creates the risk of personal injury, device damage, and electric shock due to abnormal machine operation.
 - Always check the catalog and other reference materials for correct product wiring and piping. Improper wiring and piping creates the risk of damage to and abnormal operation of the actuator, etc.
 - After completing wiring work, check to make sure that all connections are correct before turning on power.
 - After completing piping work, check to make sure that the circuit is correct before supplying air.

Safety precautions (FRZ series)

- Do not use any type of medium that is not specifically stipulated in the specifications. Using a non-specified medium could lead to loss of function in the short term, sudden degradation of performance, and a reduced operating life.
- In initial operations after the equipment has been idle for 48 hours or more, or has been in storage, there is a possibility that contacting parts may have become stuck, resulting in equipment operation delays or in sudden movements. Before these initial operations, always run a test to check that operating performance is normal.
- Do not use the product in locations that are subject to direct sunlight (ultraviolet rays); locations with high humidity and temperature, dust, salt, or iron powder. Do not use fluids in the product or use the product in an environment that includes corrosive fluids such as organic solvents, phosphate ester type hydraulic oil, sulfur dioxide, chlorine gas, flon gas, ozone, acids, alkaline, etc. It could lead to early shutdown of some functions, a sudden degradation of performance, and a reduced operating life. For information about materials, see Major Parts and Materials.
- When the device is not used for long periods (over 30 days), it is possible that the contacting parts may have become stuck leading to delayed operation or sudden movements, resulting in injury. Check for proper operation a minimum of once every 30 days.
- Do not place the wiring that controls the pressure switch near power lines running a large current, powerful magnetic fields, or where power surges occur. It could cause erratic operation.
- Do not use the product at the beach in direct sunlight, near mercury vapor lamps, or near equipment that generates ozone. Ozone causes rubber components to deteriorate resulting in reduced performance, or degradation or stop of functions.
- Do not use in locations where there is a heat source nearby or that are subject to radiated heat.

CAUTION

- When mounting the product, leave room for adequate working space around it. Failure to do so will make it more difficult to conduct daily inspections or maintenance, which could eventually lead to system shutdown or damage to the product.
- Whenever transporting or installing a heavy product, use a lift or supports to securely support it, and use several people to help lift it and take other precautions to ensure personal safety.
- Do not scratch, dent, or deform the product by climbing on it, using it as a scaffold, or placing objects on top of it. Doing so creates the risk of damage to or breakage of the product, resulting in operational shutdown or degraded performance.
- Always post an "operations in progress" sign for installations, adjustments, or other operations, to avoid unintentional supplying of air or electrical power, etc. Unintentional supplying of air or electricity can cause electric shock or sudden operation and may result in injury.
- Do not bring any magnetic media or memory within 3.28 ft of the product. There is a strong magnet inside the product and the magnetic field of this magnet may damage the data on the magnetic media.
- If an electric leakage occurs on the control circuit, it may cause the product to operate unexpectedly. Protect the control circuit from electricity leaks so that electricity leaks do not exceed the allowance in the product specifications.
- Use the specified lubricant to lubricate sliding parts. Not doing so leads to changes in the physical properties, deterioration of the materials used, or reduced functionality.
- Do not block the product's vent holes. The pressure will fluctuate if the air volume changes during operations. If the vents are blocked the pressure balance will be disrupted, operations will no longer be as expected resulting in injury or damage to equipment.
- Use in extremely dry air under temperatures lower than -4°F may affect the quality of the lubricating oil used. This creates the risk of degraded performance, loss of function, or other problems

ATTENTION

- When considering the possibility of using this product in situations or environments not specifically noted in the catalog or instruction manual, or in applications where safety is an

important requirement such as in aircraft equipment, combustion equipment, leisure equipment, safety equipment, and other places where human life or assets may be greatly affected, take adequate safety precautions such as allowing plenty of margin for ratings and performance, or fail-safe measures. Contact the sales department at Koganei regarding use in such applications.

- Use a protective cover and other means to ensure that the operating parts of mechanical devices are isolated and do not come into direct contact with human bodies.
- Do not configure control of the actuator in a way that could cause workpieces to fall due to power failure. Configure control of the system to prevent workpieces and other items from falling due to power failure or by emergency stops of mechanical devices.
- Attach a muffler to the exhaust port. It will reduce the noise during exhaust.
- Lock the pressure regulation knob after regulating the pressure.
- When handling the product, wear protective gloves, safety glasses, safety shoes, and other protective clothing.
- When the product can no longer be used or is no longer necessary, dispose of it appropriately as industrial waste.
- Pneumatic equipment can exhibit degraded performance and function over its operating life. Always conduct daily inspections of the pneumatic equipment, and confirm that all requisite system functions are satisfied, to prevent accidents from happening.
- For inquiries about the product, consult your nearest Koganei sales office or Koganei Overseas Department. The addresses and telephone numbers are shown on the back cover of this catalog.

Other precautions

- Always observe the following items.
 1. When using this product in pneumatic systems, always use genuine Koganei parts or compatible parts (recommended parts).
When conducting maintenance and repairs, always use genuine Koganei parts or equivalent parts (recommended parts).
Always observe the prescribed methods and procedures.
 2. Never attempt inappropriate disassembly or assembly of the product relating to basic configurations, or its performance or functions.
 3. The sales of pressure gauges with PSI indications in Japan are prohibited by the Japanese law.

Koganei shall not be held responsible for any problems that occur as a result of these items not being properly observed.

Warranty and General Disclaimer

1. Warranty Period
Koganei warrants this product for a period of no more than 180 days from the date of delivery.
2. Scope of Warranty and General Disclaimer
 - (1) The Koganei product warranty covers individual products. When a product purchased from Koganei or from an authorized Koganei distributor malfunctions during the warranty period in a way that is attributable to Koganei responsibility, Koganei will repair or replace the product free of charge. Even if a product is still within the warranty period, its durability is determined by its operation cycles and other factors. Contact your nearest Koganei sales office or the Koganei overseas department for details.
 - (2) Koganei shall not be held responsible for any losses or for any damage to other machinery caused by breakdown, loss of function, or loss of performance of Koganei products.
 - (3) Koganei shall not be held responsible for any losses due to use or storage of the product in a way that is outside of the product specifications prescribed in Koganei catalogs and the instruction manual, and/or due to actions that violate the mounting, installation, adjustment, maintenance and other safety precautions.
 - (4) Koganei shall not be held responsible for any losses caused by breakdown of the product due to factors outside the responsibility of Koganei, including but not limited to fire, natural disaster, the actions of third parties, and intentional actions or errors by you.

Handling instructions and Precautions

Precautions for the FRZ series

Design and selection

● Selection

Look at the "Handling Instructions and Precautions", "Specifications", "Various Characteristics", "Dimensions", and other technical materials for each product to make the correct decision.

Mounting (installation) and piping

● Mounting (installation) direction, support, and securing

1. The products cannot be mounted (installed) if a bending moment or twisting moment is applied to the product or piping.



Applying bending moment or twisting moment may damage the product.

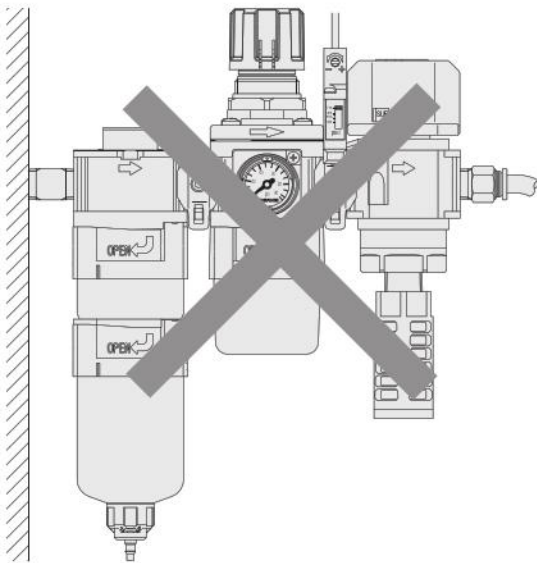

2. Do not attach piping so that just one side is fixed as shown in the following diagram. Support external piping separately.



Operating the knob and the moment caused by the OUT (secondary) side pipes may damage the product's piping connections.

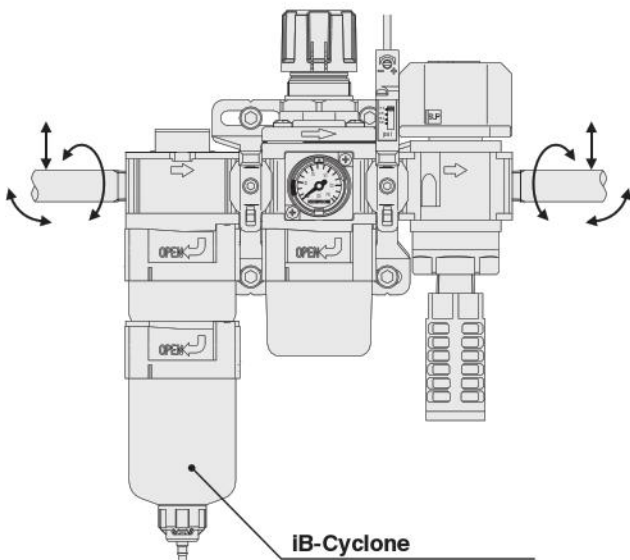

*See the back of the catalog.



The muffler must be prepared by the user.

3. Use the D□ module or a bracket to install all the products.
4. The product can be mounted (installed) in any direction. It is also possible to install it with the bowl of the filter on top.



5. When mounting (installing) the product, always make sure it is secured and sufficiently supported.



If the product is not securely fixed in place, it may fall over, be dropped, or operate abnormally and may cause an injury.

● Maintenance space requirements

Assure there is sufficient space for maintenance inspections and maintenance work. See the dimension diagrams for each of the products regarding the maintenance space.



If there is not enough allowance for maintenance space, it will be impossible to remove the filter regulator bowl assembly and replace the filter.



If there is not enough allowance for maintenance space, it will be impossible to do maintenance inspections and maintenance work so the equipment may stop or the product may be damaged.

● Direction of flow

1. Connect the filter regulators and regulators so that the medium flows in the IN port (primary) side and out the OUT port (secondary) side.
2. Connect the residual pressure exhaust valves so that the medium flows from the 1 (P) port (primary) side to the 2 (A) port (secondary) side.
3. Use the flow marks on the products to identify the direction of flow of the medium in the filter regulators, regulators, and residual pressure exhaust valves. See the "Handling Instructions and Precautions" for each product regarding the relationship of the flow marks and direction of flow of the medium being used (filter regulators, regulators on page 8 and residual pressure exhaust valves on page 12).



Connecting the products so the medium flows in reverse will cause the product to stop functioning and damage it.

Handling instructions and Precautions

Precautions for the FRZ series

●Attaching steel pipes and fittings

If steel pipes and fittings are attached to the threaded sections of the aluminum die-cast parts of the product, tighten them to the torque recommended in our standards.

NOTE Tightening with excessive torque may damage the product or injure workers or operators.

Recommended tightening torque

ft·lbf

Connecting thread	M5	1/8	1/4	3/8	1/2
Torque	0.74 to 1.11	5.2 to 6.6	8.9 to 10.3	16.2 to 17.7	20.7 to 22.1

NOTE Use a tightening torque of 2.21 to 3.69 ft·lbf if the various pressure gauges are mounted on the NPT1/4 pressure port plate.

NOTE If a muffler or something is attached to the 3 (R) port of the residual exhaust valve, tighten it to 1.33 to 1.63 ft·lbf.

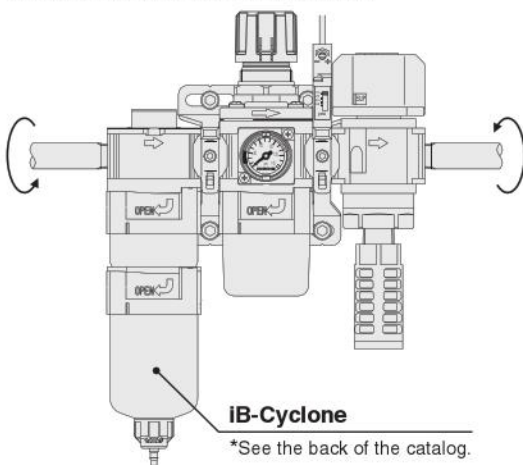

NOTE The muffler must be prepared by the user.

●Preventing contamination by foreign matter

1. Remove all foreign matter, such as metal chips, cutting oil, or dirt, from inside pipes with an air blower (flushing) and thorough washing before fitting the pipes.
2. Do not allow foreign matter, such as metal chips, or sealing tape from the piping threads, to get into the pipes when fitting the pipes.

NOTE Foreign matter entering the piping may damage the product or reduce its performance and service life.

3. Wrap the sealing tape in the direction as shown in the diagram below leaving 1.5 to 2 threads uncovered. When using liquid sealant, apply a suitable amount and leave 1.5 to 2.0 threads uncovered.

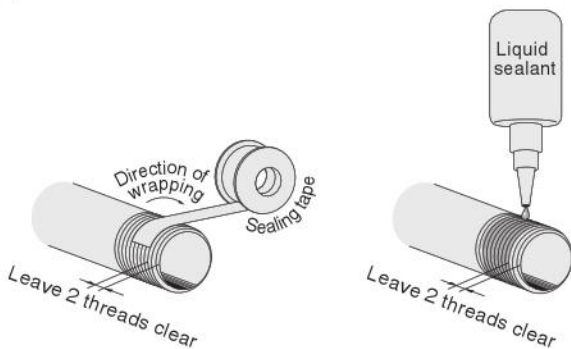

NOTE If the sealing tape or sealant gets on the lip of pipes and fittings, bits of it may get into the pipes and cause air leaks.

4. If you are using liquid sealant, do not get it on the polycarbonate parts (the bowl of the filter regulator and the front cover of the pressure gauge).

NOTE If liquid sealant gets on the polycarbonate parts, it may damage them.

Medium and operating environment

●Media

1. Use clean air (through 5 μm or smaller filter) for the supply medium. Contact the nearest Koganei sales office or overseas department if you are considering using something other than cleaned air.

2. Cannot use air that contains water and fluids.

NOTE Using air that contains water and fluids will cause the product's functions to stop after a short period and will reduce the product performance and service life.

3. If air that contains water and fluids is used, or if it is possible that they may be mixed in with the air being used, the water and fluids must be removed completely by installing a water and fluids removal device (such as the iB-Cyclone*) on the primary side. *See the back of the catalog.

4. Avoid using media that is prone to extreme pulsating or surging.

NOTE Medium prone to extreme pulsating or surges will cause the product's functions to stop after a short period and will reduce the product performance and service life.

●Operating environment

1. Do not use the product in locations that are subject to direct sunlight (ultraviolet rays); locations with high humidity and temperature, dust, salt, or iron powder.
2. Cover the unit when using it in locations where it might be subject to excessive dust, dripping water, dripping oil, etc.
3. Do not use the product in environments subject to external vibration or impact.

NOTE External vibrations or shocks may result in damage to component parts.

4. Avoid piping that is rigid, such as steel piping, if vibrations are transmitted. Use flexible tubes so that the product is not subject to the vibrations.

●Medium and operating environment

1. The temperature of the medium and the ambient environment must be within the range in the specifications.

NOTE Using the product in an environment that is outside the specified temperature or with media that is outside the specified temperature will cause the product's functions to stop after a short period and will reduce the product performance and service life.

2. Do not use media in the product or use the product in an environment that includes corrosive fluids such as organic solvents, phosphate ester type hydraulic oil, sulfur dioxide, chlorine gas, flon gas, ozone, acids, alkaline, etc.

NOTE Using the product in an environment or with media that is specified in the above item 2 will cause the product's functions to stop after a short period and will reduce the product performance and service life.

3. The bowl and the front cover of the pressure gauge of the filter regulator are polycarbonate. This product cannot be used in environments with the gases and fluids in item 2, nor thread-locking adhesive, leak detection fluid, hot water or where it may be exposed to them. This product also cannot be used in direct ultra-violet light. See page 16 for details.

Operation and maintenance inspections

●Method of use

Read the "Handling Instructions and Precautions" for each product for instructions on correct usage (Filter regulator and regulator page 8 to 12, residual pressure exhaust valve page 12 and page 13, module adapters page 14, pressure switch module page 14 and page 15, □1.181 in. integrated pressure gauge page 15).

●Maintenance (maintenance inspection)

1. Performance and functions may decrease as the pneumatic equipment ages. Always conduct daily inspections of the pneumatic equipment, and confirm that all requisite system functions are satisfied, to prevent accidents from happening.
2. Read the "Handling Instructions and Precautions" for instructions on correctly doing maintenance and replacing maintenance parts (Filter regulator and regulators page 11 and page 12).
3. The product must be disassembled and reassembled to use the seal kit.

NOTE The product is no longer under warranty if it is disassembled or reassembled.



Filter regulator Regulator

Design and selection

●Pressure setting

1. A safety device must be installed for equipment/devices installed on the OUT port (secondary) side of the filter regulator or the regulator, because the equipment/device will be damaged or malfunction due to the pressure if the set pressure value is exceeded.
2. We recommend setting the pressure on the OUT port (secondary) side to less than 85% of the supply pressure setting on the IN port (primary) side.

NOTE If the pressure is set above 85%, the effect of the fluctuations in the IN port (primary) side pressure and flow rate are more prone to affect the OUT port (secondary) side pressure, and it becomes unstable.

3. It is not possible to install a valve on the IN port (primary) side of the internal pilot type filter regulator or regulator (such as models FRZ4□, FRZ5□, RZ4□, RZ5□) to repeatedly switch the pressure on the IN port (primary) side.

NOTE Changing the pressure of the IN port (primary) side may cause fluctuation in the OUT port (secondary) side set pressure.

4. The OUT port (secondary) side pressure may fluctuate if air is not consumed for a long time or if a sealed circuit or balance circuit is used. Contact your nearest Koganei sales office or overseas department.
5. Contact your nearest Koganei sales office or overseas department if you are using a circuit that needs highly precise pressure regulation.

●OUT Port (secondary) side pressure exhaust and vent hole

1. When the knob on the filter regulator or regulator is turned to reduce the OUT port (secondary) side pressure or when the OUT port (secondary) side pressure is higher than the set pressure and is exhausted, air is exhausted to the outside through the vent hole shown in the diagram.

NOTE There may be some vibration and noise caused by the exhaust.

2. Install a separate exhaust mechanism on the OUT port (secondary) side if an external force applied to an actuator or something on the OUT port (secondary) side of the filter regulator or regulator generates a sudden pressure increase.

NOTE The relief port is smaller than the diameter of the pipe and may not be able to adapt to the sudden rise in pressure of the OUT port (secondary) side.

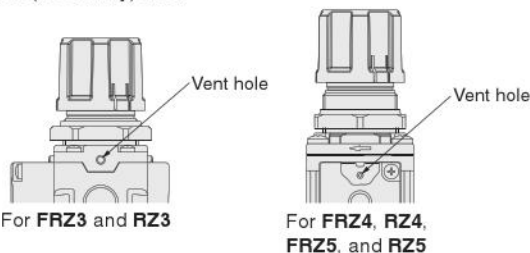

●Reverse flow from the OUT port (secondary) side to the IN port (primary) side (residual pressure exhaust)

1. Select the filter regulator or regulator (such as models FRZ32 and RZ32) with built in check mechanism specifications to release residual pressure on the IN port (primary) side to reduce pressure on the OUT port (secondary) side of the direct operation type filter regulator and regulator (such as models FRZ3□ and RZ3□).

NOTE Residual pressure processing on the OUT port (secondary) side with the standard specifications and low-pressure specifications may not be possible depending on the operating conditions.

2. The internal pilot type filter regulators and regulators (such as models FRZ4□, FRZ5□, RZ4□, RZ5□) use the relief port on the OUT port (secondary) side to reduce residual pressure when the IN port (primary) side pressure is released.
3. When using a built-in check mechanism specification filter regulator or regulator (such as models FRZ32 or RZ32) installed after the valve to adjust the thrust of the actuator, set the pressure on the OUT port (secondary) side of the built-in check mechanism specification filter regulator or regulator not to rise above the set pressure, which may be caused by the back pressure of the actuator (As a guideline, the difference in pressure for the push side and the pull side of the actuator should be 43.5 psi or less.)

<Reference> Improving the system with a filter regulator or regulator with built-in check mechanism.

The filter regulator or regulator with built-in check mechanism releases pressure from the OUT port (secondary) side pressure to the IN port (primary) side as the main valve temporarily opens, because the pressure balance is disrupted when the built-in check valve is open as the IN port (primary) side pressure is lost. Due to easy change of the thrust of the pushing and pulling sides of the actuators, you can reduce air consumption by operating with low pressure on the side which does not need thrust.

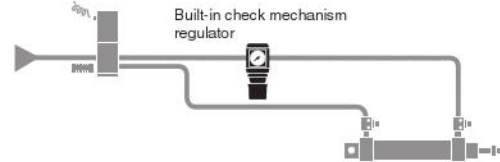

●Water and fluids removal

The filter regulator does not have a water and fluids removal function.

●Air consumption

1. The internal pilot type filter regulators and regulators (such as models FRZ4□, FRZ5□, RZ4□, RZ5□) consume air while regulating pressure on the OUT port (secondary) side.
2. Air consumption varies depending on the relationship of the IN port (primary) side pressure and the OUT port (secondary) side pressure.
3. The internal pilot type filter regulators and regulators (such as models FRZ4□, FRZ5□, RZ4□, RZ5□) reduce pressure by consuming air when the IN port (primary) side and OUT port (secondary) side are cut off and sealed.

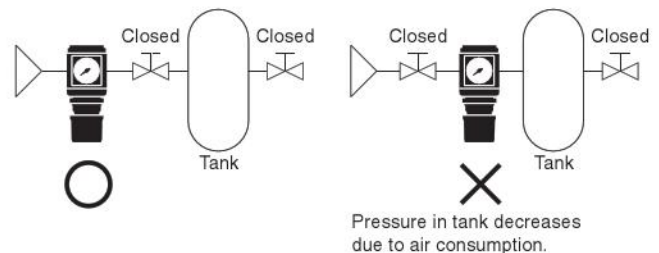

Mounting (installation) and piping

●Flow mark

The following diagram shows the relationship of the direction of flow of the media and the flow mark on the filter regulator or regulator.

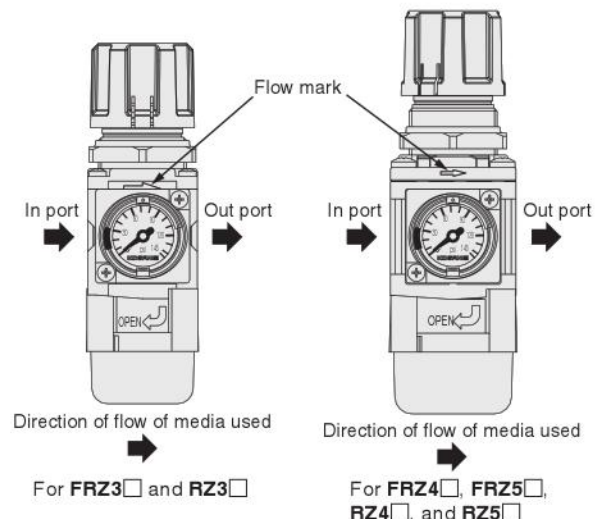

Handling instructions and Precautions



Filter regulator Regulator

●Piping work

Connect pipes and fittings to the filter regulator and regulator IN ports and OUT ports so that the weight and torque of the pipes do not affect the product. When tightening the piping, grip the main unit and tighten it to the torque recommended on page 7.



Applying unnecessary force or impact to the knob, bowl assembly, or pressure gauge may damage component parts.

●Installing brackets

To install brackets, do it in the following order.

- ① Remove the knob.
(For how to remove the knob see "Removing the knob" on page 10.)
- ② Attach the bracket.
- ③ Screw on the mounting ring.



Tighten the mounting ring to less than 2.21 ft·lbf.

- ④ Attach the knob.
(For how to attach the knob see "Attaching the knob" on page 10.)

●Panel mount

1. All the mounting holes for the filter regulator and regulators for the panel mount installation are ϕ 1.122 in.
2. See the following table for the thickness of panels.

Model	FRZ3□ RZ3□	FRZ4□ RZ4□	FRZ5□ RZ5□
Thickness	0.118 or less	0.276 or less	



Using a panel that is thicker than specified may make it impossible to secure the mounting ring or decrease the visibility of the yellow caution ring.

3. Use the following procedure to install with a panel mount.

- ① Remove the knob.
(For how to remove the knob see "Removing the knob" on page 10.)
- ② Attach the filter regulator or regulator to the panel.
- ③ Screw on the mounting ring.



Tighten the mounting ring to less than 2.21 ft·lbf.

- ④ Attach the knob.
(For how to attach the knob see "Attaching the knob" on page 10.)

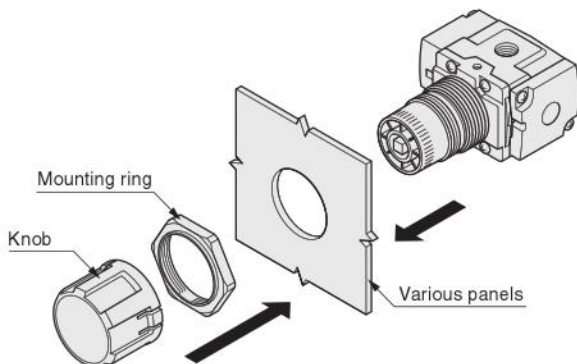

Operation and maintenance inspections

●Locking and releasing the knob

1. The Knobs on the filter regulators and regulators use a push lock mechanism.
Use the procedure shown below to lock and release the knob.

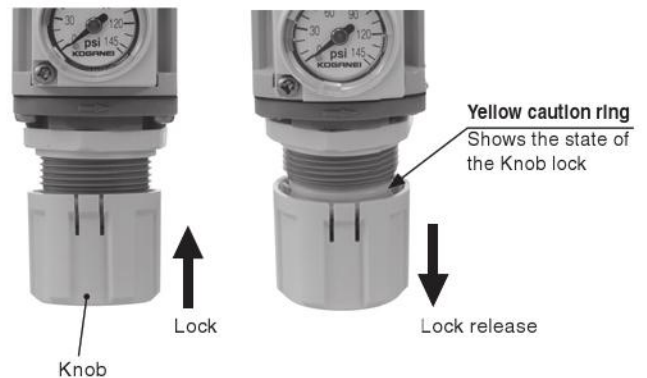

2. Always release the knob lock when regulating the pressure.



Turning the knob while it is locked may damage component parts.

3. Lock the knob after regulating the pressure.

●Pressure regulation

1. Pressure regulation is done as shown in the following diagram by turning the knob in the "+" direction to increase pressure and in the "-" direction, shown at the base of the knob, to reduce it.

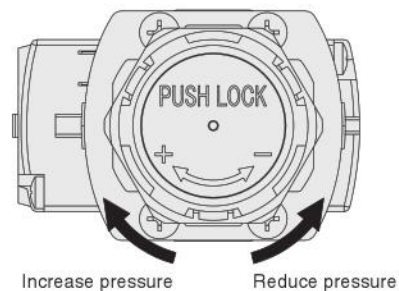

2. Start at a low pressure and match it to the desired set pressure when regulating the pressure. If you exceed the desired pressure, lower the pressure again and start from a low pressure again to set the pressure.



Starting from a high pressure to set the desired pressure causes unstable pressure on the OUT port (secondary) side.

3. Use a pressure gauge to check the pressure on the IN port (primary) side and OUT port (secondary) side while regulating the pressure.

4. It is possible to increase the set pressure to exceed the upper limit of the pressure setting range by turning the knob to the upper limit of the "+" side, but keep the regulated pressure within the pressure setting range.



Turning the knob farther than necessary may damage component parts.

●Removing the knob

Use the following procedure to remove the knob.

- ① Release the knob lock.
(For how to release the knob lock see "Locking and releasing the knob lock" on page 9.)
- ② Turn the mounting ring counterclockwise (in the direction of the arrow in the diagram below).

NOTE Turn the mounting ring until it comes off the threads.

- ③ Pull the mounting ring over in the direction of the knob.

NOTE The release sleeve of the mounting ring must be pulled up until it spreads the hooks (3 places) on the knob.

- ④ Pull off the knob and the mounting ring together.

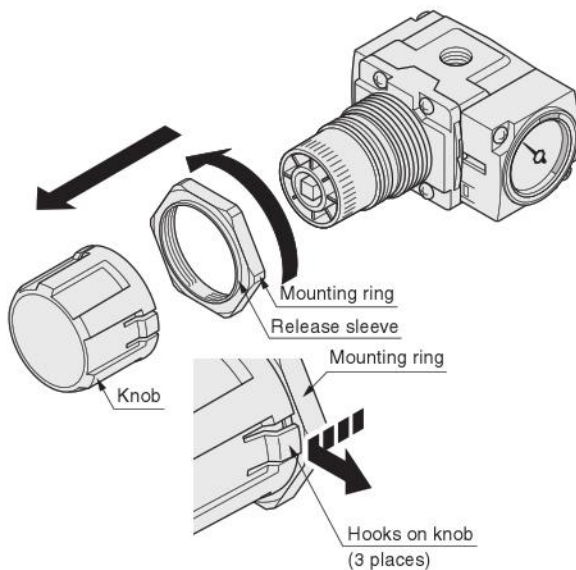

●Attaching the knob

1. Use the following procedure to attach the knob.

- ① Release the pressure of the IN port (primary) side to the atmosphere.

- ② Screw on the mounting ring.

NOTE Installing the knob before screwing on the mounting ring makes it impossible to attach the mounting ring and makes the knob difficult to remove.

- ③ Press the knob in until the yellow caution ring is not visible.

NOTE Before pressing on the knob, align the square section of the adjusting assembly and the square indented portion of the base of the knob to make the knob easier to press on (on page 1).

2. Attaching the knob while the filter regulator or regulator IN ports (primary) side pressure is being supplied, may cause a temporary rise in pressure on the OUT port (secondary) side pressure.

Before attaching the knob, always release pressure on the IN port (primary) side to the atmosphere, because a temporary increase in pressure on the OUT port (secondary) side may occur which may damage equipment or devices on the OUT port (secondary) side or cause a malfunction.

NOTE It may damage the equipment or devices or injure workers or operators.

3. If it is impossible to release the pressure on the IN port (primary) side to the atmosphere, the pressure on the OUT port (secondary) side will rise temporarily, check for any effect it may have had on equipment and devices that are installed after the filter regulator or regulators, and then attach the knob.

●Changing the □1.181 in. integrated pressure gauge and pressure port plate

Use the following procedure to rotate the □1.181 in. integrated pressure gauge 180°, and to change the □1.181 in. integrated pressure gauge or pressure port plate.

- ① Remove the two small screws.
- ② Remove any metal chips from the female thread hole with an air blower.

NOTE If there are any metal chips left, they may break the threads or get on the o-ring and cause an air leak.

- ③ Put the o-ring on the □1.181 in. integrated pressure gauge or pressure port plate.

NOTE Not using an o-ring will result in air leaks.

- ④ Align the groove on the □1.181 in. integrated pressure gauge or pressure port plate with the tongue on the main unit and attach it.

- ⑤ Tighten the two mounting screws to 0.66 to 0.81 ft·lbf

NOTE If torque exceeding the specifications is applied, the head of the screw or threads may be damaged and cause damage to component parts. Also, if torque below the specifications is used, the screw may come loose and cause an air leak.

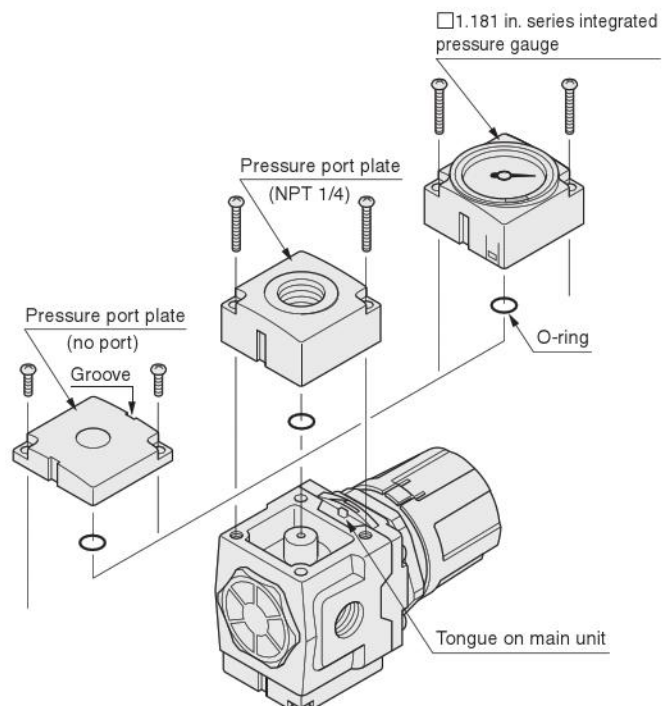

Handling instructions and Precautions



Filter regulator Regulator

●Installing provided options

1. When installing the various types of pressure gauges, always apply the wrench on the square or hexagonal part of the piping connections.



Gripping the body of the various pressure gauges to tighten them may damage component parts.

2. Use a tightening torque of 2.21 to 3.69 ft·lbf if the various pressure gauges are mounted on the NPT1/4 port plate provided.



If torque exceeding the specifications is applied, it may damage component parts. Also, if torque below the specifications is used, the screw may come loose and cause an air leak.

3. There is a stopper on the NPT1/4 female thread of the NPT1/4 pressure port plate.



Further tightening after the stopper has been reached may damage component parts.

●Replacing the pressure port plate, knob, and mounting ring

1. When replacing the pressure port plate, refer to "Replacing the □1.181 in. integrated pressure gauge and pressure port plate" on page 10.
2. When replacing the knob and mounting ring, refer to "Removing the knob" and "Attaching the knob" on page 10.

●Replacing the seal kit, element, and bowl assembly

1. To replace the seal kit, element, and bowl assembly, remove the filter regulator or regulator and do the work on a work table.
2. The o-rings and other sealing materials (except for the diaphragm) of the filter regulator and regulator are coated with grease.
3. Contact your nearest Koganei sales office or overseas department if you are considering re-coating the o-rings and other parts.
Recommended grease: Lithium Soap based No. 2 or equivalent
4. Periodically replace the element in the filter regulator.



The service life of the element varies depending on the quality of air supplied to the IN port (primary) side. If there is a lot of foreign matter in the air supply to the IN port (primary) side, install a pre-filter on the IN port (primary) side or change the element more often. As a guideline, change the element after a year of use.

5. When replacing the seal kit, element, and bowl assembly, be careful not to lose component parts.

6. Refer to the diagram at right when replacing the seal kit, element, and bowl assembly.



Always assemble the component parts correctly.

Filter regulator bowl side

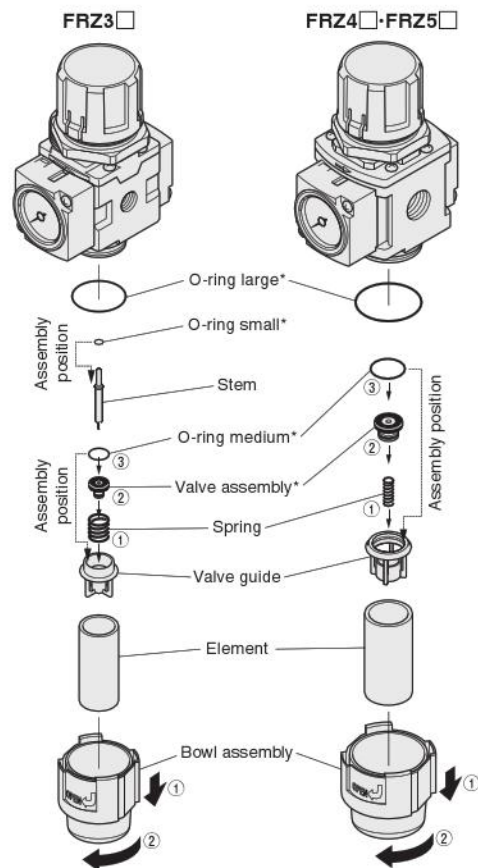

*Parts in seal kit.



The product is no longer under warranty if it is disassembled or reassembled.

Regulator and filter regulator knob side

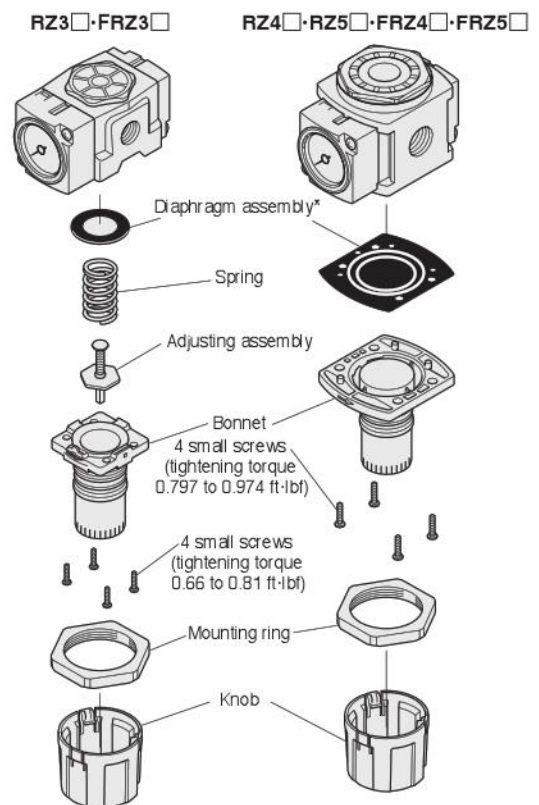

*Parts in seal kit.



The product is no longer under warranty if it is disassembled or reassembled.

Regulator plug side

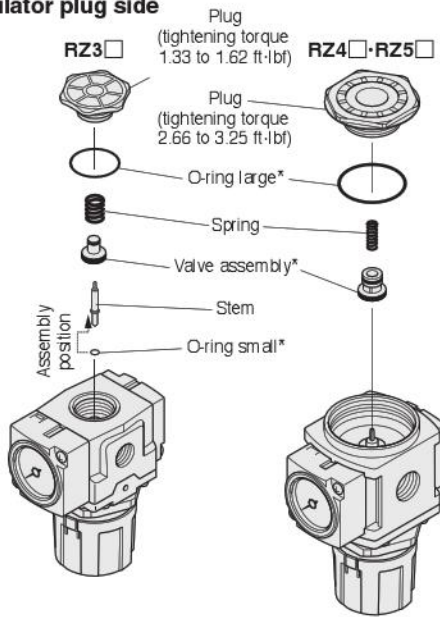

*Parts in seal kit.



The product is no longer under warranty if it is disassembled or reassembled.

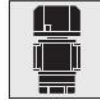

Residual pressure exhaust valve

Mounting (installation) and piping

●Flow mark

The following diagram shows the relationship of the direction of flow of the media and the flow mark on the residual pressure exhaust valve.

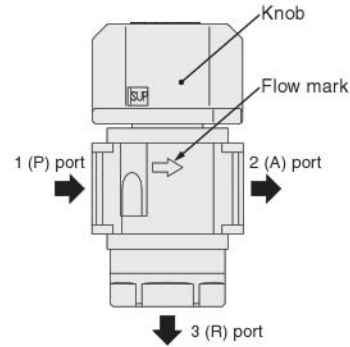

●Piping work

1. Connect pipes and fittings to the residual pressure exhaust valve 1 (P) port and 2 (A) port so that the weight and torque of the pipes do not affect the product. When tightening the piping, grip the main unit and tighten it to the torque recommended on page 7.



Applying unnecessary force or impact to the knob may damage component parts.

2. If a muffler or something is attached to the 3 (R) port of the residual exhaust valve, tighten it to 1.33 to 1.62 ft·lbf.



The muffler must be prepared by the user.



If torque exceeding the specifications is applied, it may damage component parts. Also, if torque below the specifications is used, the screw may come loose.

●Installing brackets

To install brackets, do it in the following order.

- ① Attach the bracket.
- ② Tighten the two mounting screws to 0.915 to 1.11 ft·lbf.



If torque exceeding the specifications is applied, the head of the screw or threads may be damaged and cause damage to component parts. Also, if torque below the specifications is used, the screw may come loose and cause an air leak.

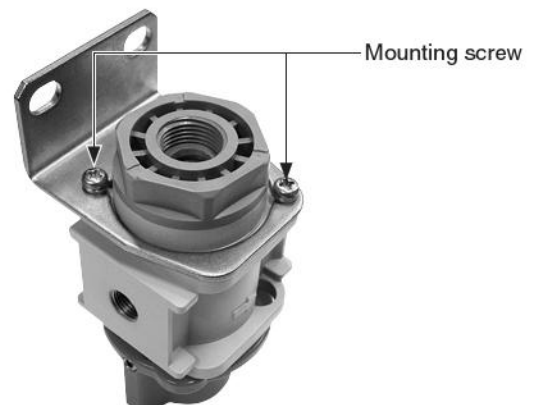

Mounting screw

Handling instructions and Precautions

Operation and maintenance inspections

● State of air supply and exhaust

1. State of air supply is that air flows through from 1 (P) port (primary) side to 2 (A) port (secondary) side and is shut off at the 3 (R) port.
2. State of air exhaust is that air flows through from 2 (A) port (secondary) side to 3 (R) port and is shut off at 1 (P) port (primary) side.

● Switching the state of air supply and exhaust

1. To switch the air flow from supply to exhaust and vice versa, turn the knob 90° to "SUP", which is shown near the bottom of the knob, to supply air, or turn the knob 90° to "EXH" to exhaust air.

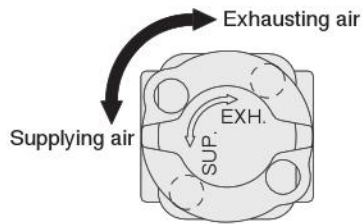

2. Check the window shown in the diagram below to see the state of the residual pressure exhaust valve. If "SUP" is showing, air is being supplied. If "EXH" is showing, air is being exhausted.



SUP : Supplying air



EXH : Exhausting air

3. Turn the knob slowly to gradually supply or exhaust air.

NOTE 1(P) port (primary) side air cannot flow to 2 (A) port (secondary) side and 3 (R) port at the same time.

● Using the lock hole

1. The lock hole on the residual pressure exhaust valve is used to secure the air flow in a state of exhaust and to prevent changes to the state of the air supply.

NOTE Air cannot be supplied while the lock hole is used.

2. The diameter of the lock hole is $\phi 0.394$ in.
3. A lock must be supplied separately.



Lock (provided by the customer)



Module adapter

Mounting (installation) and piping

●Mounting (installation)

1. Use the various modules and adapters when combining the relevant FRZ series models and the relevant iB-Cyclone* models.
*See the back of the catalog.
2. Refer to "List of models" on page 39 regarding combinations of the relevant models, modules, and adapters.

NOTE The FRZ3□, RZ3□, and IBCY30 cannot be used together.

3. When assembling the products, check the flow marks on the products and assemble them so the media flows in the same direction. See the "Handling Instructions and Precautions" for each product regarding the relationship of the flow marks and direction of flow of the medium being used (filter regulators, regulators on page 8 and residual pressure exhaust valves on page 12).

4. Use the following procedure to assemble the products using the modules and adapters.

- ① Attach the o-rings to the connecting bracket (2 places)

NOTE Not using an o-ring will result in air leaks.

- ② Temporarily fix the products to the coupling plate.
- ③ Tighten a hexagon socket head screw to 0.66 to 0.81 ft•lbf.

NOTE If torque exceeding the specifications is applied, it may damage component parts. Also, if torque below the specifications is used, the screw may come loose.

<Example assembly>

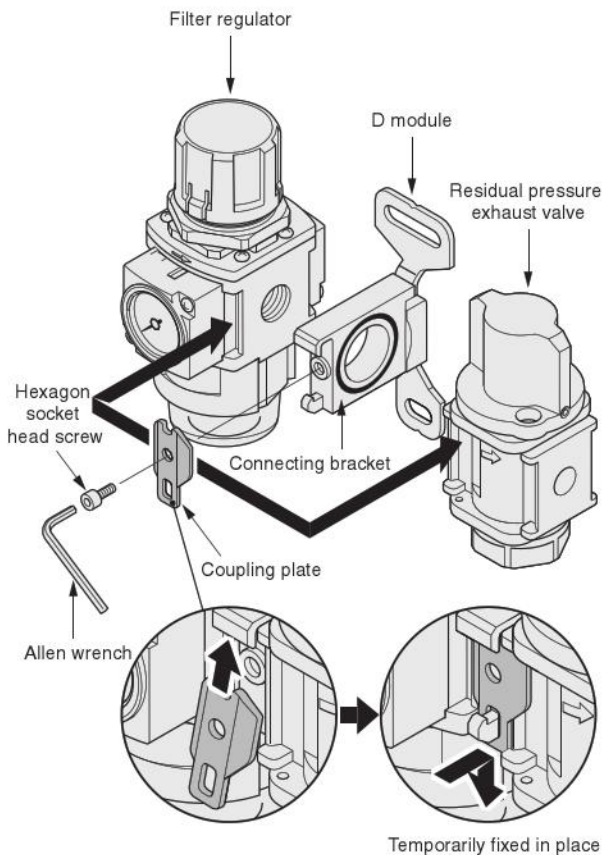

Pressure switch module

Mounting (installation) piping

●Mounting (installation)

1. The method to install the pressure switch modules is the same for the various modules and adapters. Refer to the "Handling Instructions and Precautions" for the modules and adapters.
2. Do not pull too hard on the wires or bend them too much. Also, when handling the products, carry them by the pressure switch side and do not apply too much force to the wires.
3. Be careful when handling the pressure switch modules, subjecting them to strong impact may cause damage or malfunction.

●Contact capacity

Use the specified load voltage and load current.

NOTE Using a load voltage or a load current that is outside the specifications may cause the contacts to fuse.

●Contact protection measure

The pressure switch module uses a reed sensor switch. Take the contact protection measures shown in the diagram below.

NOTE Contacts may fuse if measures to protect the contacts are not taken.

For connecting an inductive load (electromagnetic relay etc)

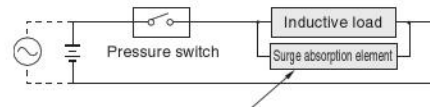

For DC ... Diode or CR, etc.

For AC ... CR etc.

Diode: Forward current should be more than the circuit current and the reverse current should be 10 times greater or more than the circuit voltage.

CR: C=0.01 to 0.1 μF

R=1 to 4 kΩ

If a capacitive surge occurs (if wire length is 32.8 ft)

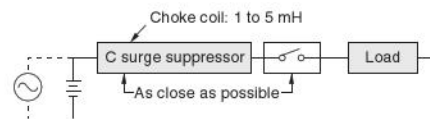

Medium and operating environment

●Operating environment

The pressure switch module uses a magnetically sensitive sensor switch.

Avoid large electric currents, such as locations where there is a strong magnetic field or near power lines.

NOTE Use in locations with strong external magnetic fields or near strong electric currents may cause the pressure switch module to malfunction.

Handling instructions and Precautions

Operation and maintenance inspections

●Detection pressure scale

1. Use a detection pressure scale as a guideline.

NOTE Use a multi meter to confirm the output of the pressure switch module.

NOTE To accurately set the detected pressure, use a separate pressure gauge.

- Detection pressure scale is for the set value when the supplied pressure falls.
- Detection pressure scale is for the set value when the OFF signal is detected.

NOTE The ON signal is detected when the pressure exceeds the set pressure on the detection pressure scale by the response differential.

●Settings for the detection pressure

1. The detection pressure can be set to a value over the range of detection pressure, but always set it within the specified values.

NOTE Setting the pressure over the range of the detection pressure will damage component parts.

2. Use the following procedure to set the detection pressure.

- Turn the adjusting screw toward the "+" until the regulating indicator is aligned with the desired detection pressure on the scale.
- Supply pressure and use a multi meter to confirm that the signal indicates the desired pressure setting is detected.

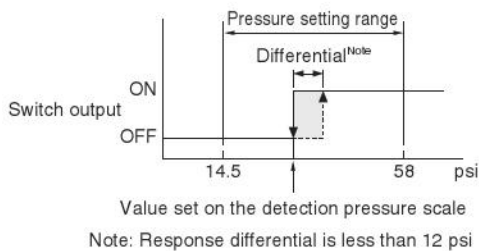
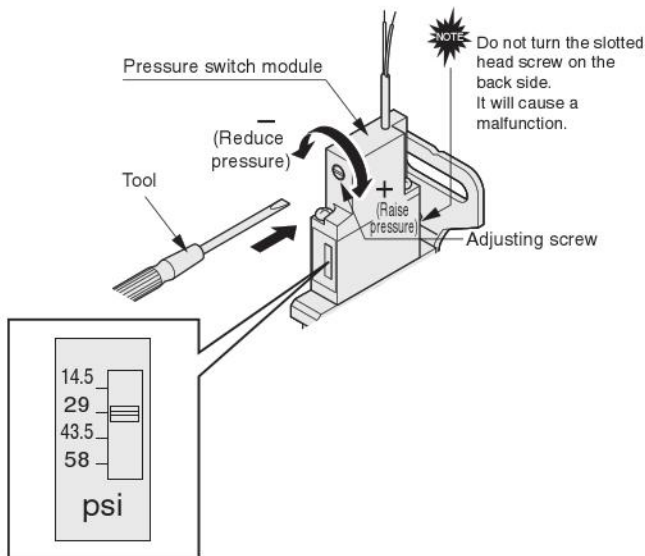

□1.181 in. series integrated pressure gauge

Mounting (installation) and piping

●Mounting (Installation)

- Read the "Handling Instructions and Precautions" for the filter regulator and regulator when installing the □1.181 in. integrated pressure gauge to the filter regulator or the regulator.
- Install the □1.181 in. integrated pressure gauge to the filter regulator or regulator in the orientation shown in the diagram below.

NOTE It is possible to change the □1.181 in. integrated pressure gauge installation to a 180° orientation, but it is not possible to change it to a 90° orientation.

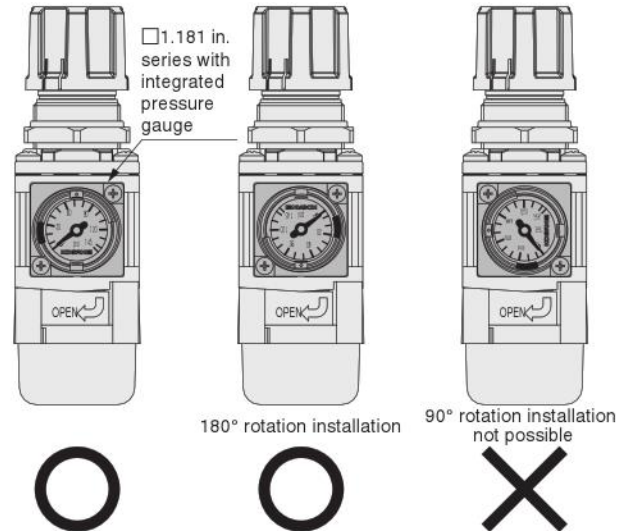

Medium and operating environment

●Surging, vibration, and shock

The □1.181 in. integrated pressure gauge is a precision device. It cannot be used if the medium surges, or external vibration or shock is applied.

NOTE Surges in the media, external vibrations or shocks may result in damage to component parts.

Operation and maintenance inspections

●Adjusting the range of the set pressure

- Use the procedure below to adjust the range of the set pressure (the green portion).
 - Adjust the lower limit of the range of the set pressure by rotating the protrusions (2 places) clockwise with your hand.
 - Adjust the upper limit of the range of the set pressure by rotating the protrusions (2 places) clockwise with your hand.

NOTE Adjusting the range of the set pressure with a tool may damage component parts.

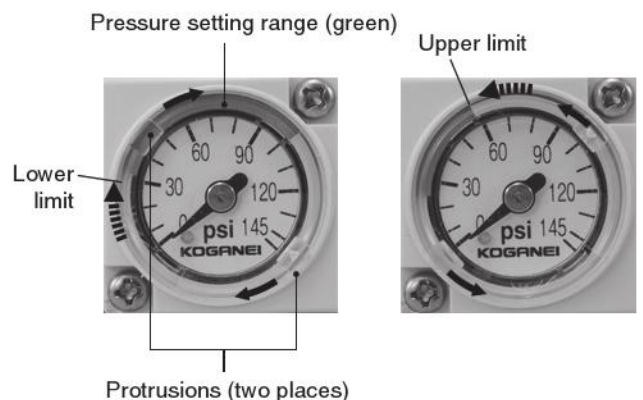

Reference data

● About the chemical resistance of polycarbonate

The chemicals in the following table degrade polycarbonate. Because of this, they may damage the bowl of the filter regulator or the front cover of the pressure gauge and cause an accident. The products cannot be used in locations where the chemicals in the following table are present in the compressed air, ambient air, or on surfaces. This does not mean that polycarbonate is chemically resistant to all chemicals not listed below.

Type	Classification	Chemical name	Application example
Inorganic compound	Acid	Chlorine, sulfuric acid, nitric acid, fluorine, phosphoric acid, chromic acid	Acid cleaning for metals, acid degreasing, and coating processing
	Alkali	Caustic soda, caustic potash, hydrated lime, ammonia water, sodium carbonate	Alkaline degreasing of metals
	Inorganic salt	Sodium sulfide, potassium nitrate, potassium dichromate, sodium nitrate	Dyes, rust inhibitor
Organic compounds	Aromatic hydrocarbons	Benzene, toluene, xylene, ethyl benzene, styrene	Paint thinner (Benzene, toluene, xylene)
	Chlorinated aliphatic hydrocarbons	Methyl chloride, ethylene chloride, methylene chloride, acetylene dichloride, chloroform, trichlene, tetrachloroethylene, carbon tetrachloride	Organic solvents for metal cleaning (trichlene, tetrachloroethylene, carbon tetrachloride)
	Chlorinated aromatic hydrocarbons	Chlorobenzene, dichlorobenzene, benzene hexachloride (BHC)	Agricultural chemicals
	Petroleum components	Solvent, naphtha, gasoline	Fuel
	Alcohol	Methyl alcohol, ethyl alcohol, cyclohexanol, benzyl alcohol	Anti-freezing agents
	Phenol	Carbolic acid, cresol, naphthol	Antiseptic solutions
	Ether	Methyl ether, methyl ethyl ether, ethyl ether	Brake fluid additive, detergent
	Ketones	Acetone, methyl ethyl ketone, cyclohexane, acetophenone	Cleaning solutions
	Carboxylic acid	Formic acid, acetic acid, butyl acid, acrylic acid, oxalic acid, phthalic acid	Dyes, aluminum processing solution (oxalic acid), paint medium (phthalic acid)
	Phthalic acid ester	Dimethyl phthalate (DMP), diethyl phthalate (DEP), dibutyl phthalate (DBP), dioctyl phthalate (DOP)	Lubricants, synthetic hydraulic fluids, corrosion resistant additives, synthetic resin plasticizer
	Oxyacid	Glycolic acid, lactic acid, malic acid, citric acid, tartaric acid	Food preservatives, acidulant
	Nitro compounds	Nitromethane, nitroethane, nitroethylene, nitrobenzene	Paint solvent, explosives
	Aminos	Methylamine, dioctylamine, ethylamine, aniline, acetanilide	Brake fluid additive
Nitrile	Acetonitrile, acrylonitrile, benzonitrile	Nitrile rubber materials	

Residual pressure exhaust valve

50VZ-F11



Symbol

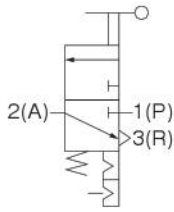

Specifications

Item	Model	50VZ-F11-01	50VZ-F11-02	50VZ-F11-03	50VZ-F11-04		
Media		Air					
Port size NPT	1 (P) and 2 (A)	1/8	1/4	3/8	1/2		
	3 (R)	3/8					
Maximum operating pressure	psi	145					
Proof pressure	psi	218					
Operating temperature range (atmosphere and media)	°F	41 to 140					
Method of operation		Manually operated Knob					
Number of positions and ports		2 positions and 3 ports					
Operating torque of knob	ft·lbf	0.74					
Knob operation angle		90°					
Flow rate characteristics	1 (P) → 2 (A)	Sonic conductance C	dm ³ /(s·bar)	4.28	8.60	12.46	13.36
		Critical pressure ratio	b	0.23	0.38	0.21	0.31
		Effective area [Cv] ^{Note}		1.19	2.39	3.46	3.71
	2 (A) → 3 (R)	Sonic conductance C	dm ³ /(s·bar)	7.87	11.00		
		Critical pressure ratio	b	0.89	0.32		
		Effective area [Cv] ^{Note}		2.19	3.06		
Materials of major parts	Body	Die cast aluminum alloy					
	Knob	Polyacetal					
Mass	lb	0.49	0.49	0.46	0.44		
Options		Bracket {Steel plate (electroless nickel plated)}					

Note: The effective areas are calculated values, and they are not measured values.

Remark 1: Specified values are according to Koganei test standards.

2: The muffler must be provided by the user.

Order codes

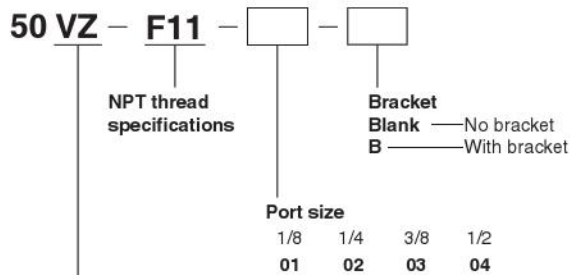

Residual pressure exhaust valve

● Order codes for bracket only

8Z-BV



Inner construction

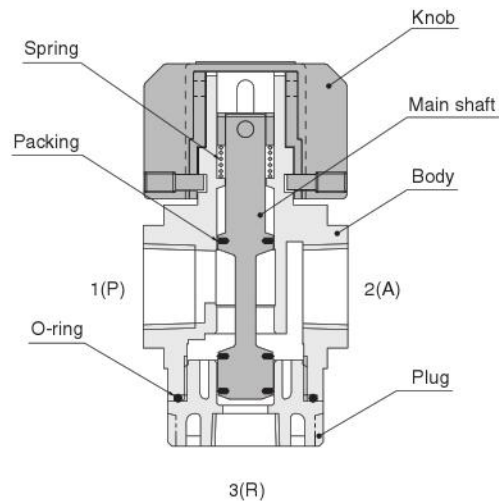

Flow rate characteristics

Air supply flow rate

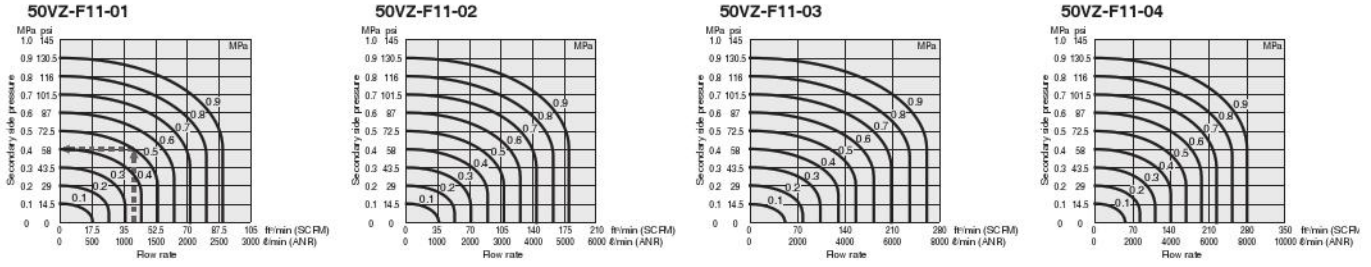

Explanation of diagrams

At supply pressure of 73 psi and flow rate of 40.6 ft³/min (SCFM) gives valve outlet pressure of 58 psi.

1 MPa = 145 psi
1 l / min = 0.0353 ft³/min

Exhaust flow rate

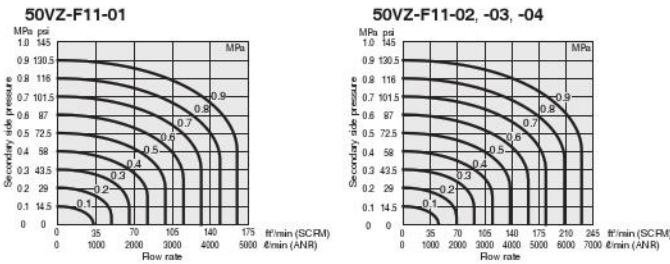

1 MPa = 145 psi
1 l / min = 0.0353 ft³/min

Residual pressure exhaust valve dimensions in.

50VZ-F11

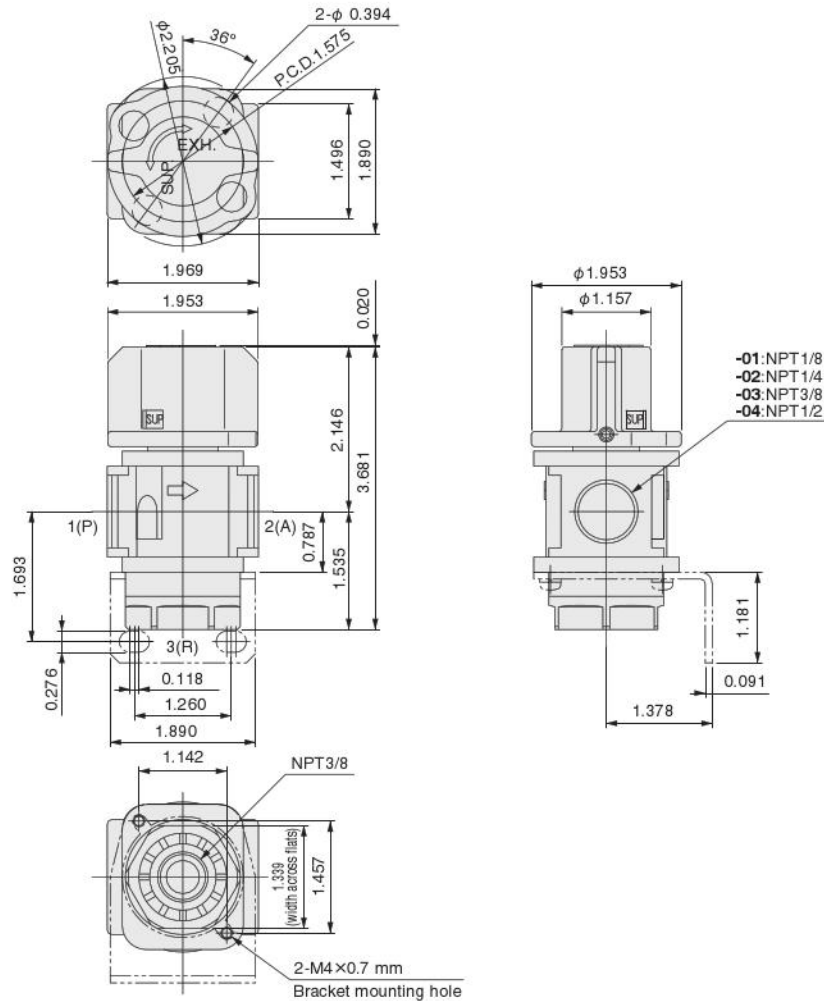

Module adapter

Order codes

8Z —

Module adapter

- F — F module (for connecting)^{Note}
- D — D module (for connecting, with bracket)^{Note}
- DP — Module bracket^{Note}
- FP — Coupling plate^{Note}

8Z — — — F11

Port size^{Note}

NPT1/8 NPT1/4 NPT3/8 NPT1/2
1 2 3 4

Module adapter



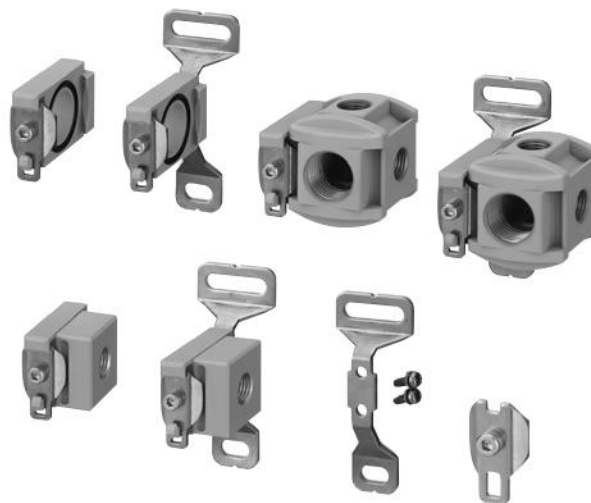





- T — T module (for branching)
- DT — DT module (for branching, with bracket)
- S — S adapter (for changing pipe size)
- DS — DS adapter (for changing pipe size, with bracket)



Note: The port size cannot be selected for the F module (F), D module (D), module bracket (DP), and coupling plate (FP).

Note: Modules and adapters cannot be assembled with the filter regulator FRZ3□-F11 and the regulator RZ3□-F11.

List of models

F module (for connecting)	D module (For connecting with bracket)	T module (For branching)	DT module (For branching, with bracket)
8Z-F	8Z-D	8Z-T□-F11	8Z-DT□-F11
			
<p>●Compatible models Filter regulators: FRZ40-F11, FRZ41-F11, FRZ50-F11, FRZ51-F11 Regulators: RZ40-F11, RZ41-F11, RZ50-F11, RZ51-F11 Residual pressure exhaust valve: 50VZ-F11 iB-Cyclone: IBCY40-F11, IBCY50-F11</p>			
S adapter (for changing pipe size)	DS adapter (for changing pipe size, with bracket)	Module bracket	Coupling plate
8Z-S□-F11	8Z-DS□-F11	8Z-DP	8Z-FP
			
<p>●Compatible models Filter regulators: FRZ40-F11, FRZ41-F11, FRZ50-F11, FRZ51-F11 Regulators: RZ40-F11, RZ41-F11, RZ50-F11, RZ51-F11 Residual pressure exhaust valve: 50VZ-F11 iB-Cyclone: IBCY40-F11, IBCY50-F11</p>			

[Materials of major parts] Connecting bracket, intermediate branch block, piping adapter: die cast aluminum alloy
 Module bracket, coupling plate: Steel plate (electroless nickel plated)

F module dimensions in.

● 8Z-F

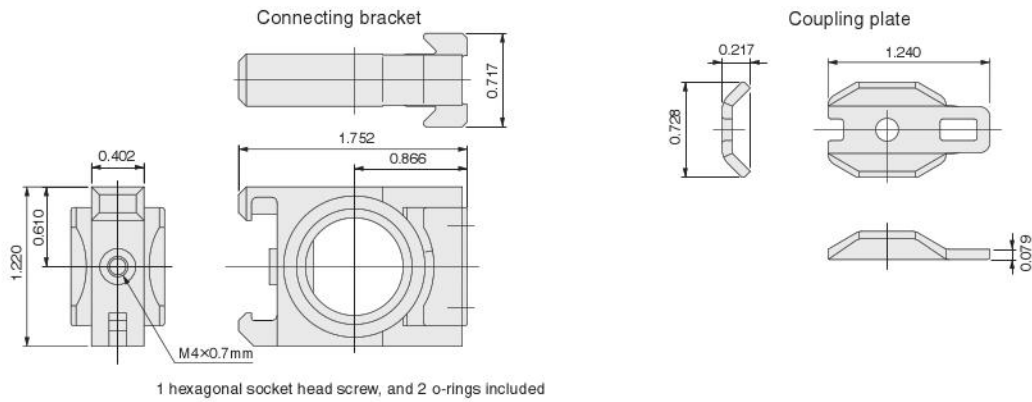

D module dimensions in.

● 8Z-D

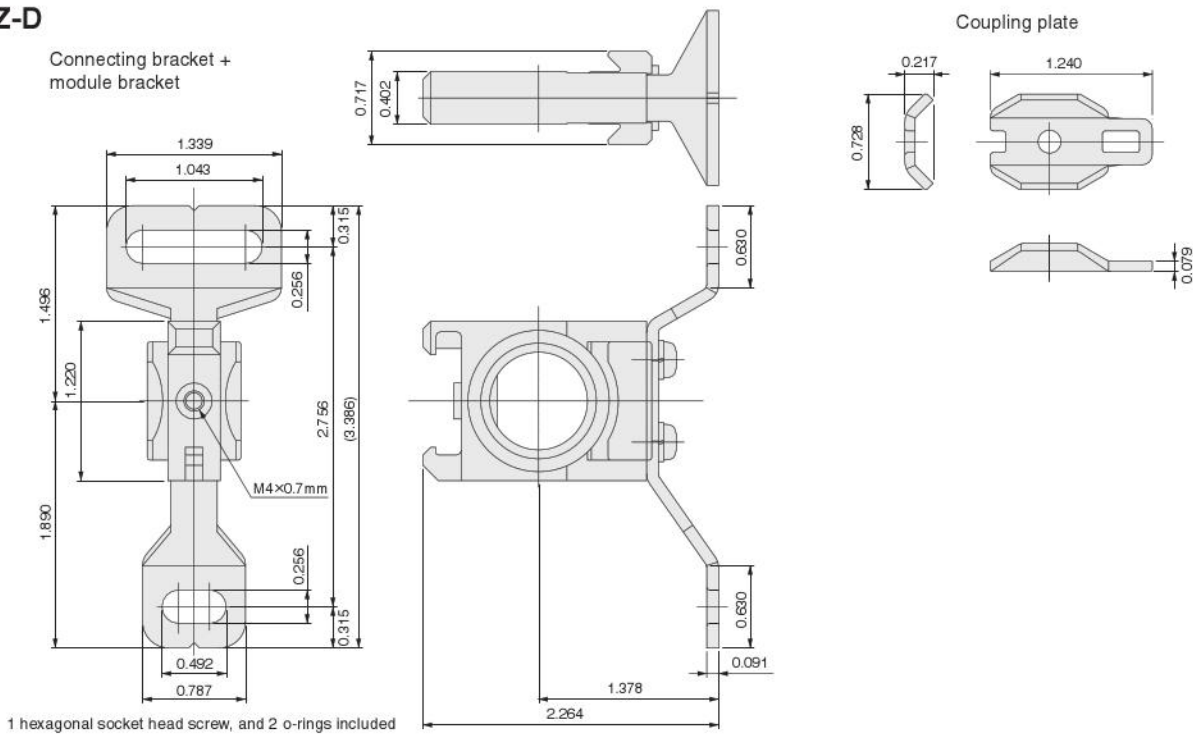

T module dimensions in.

● 8Z-T□-F11

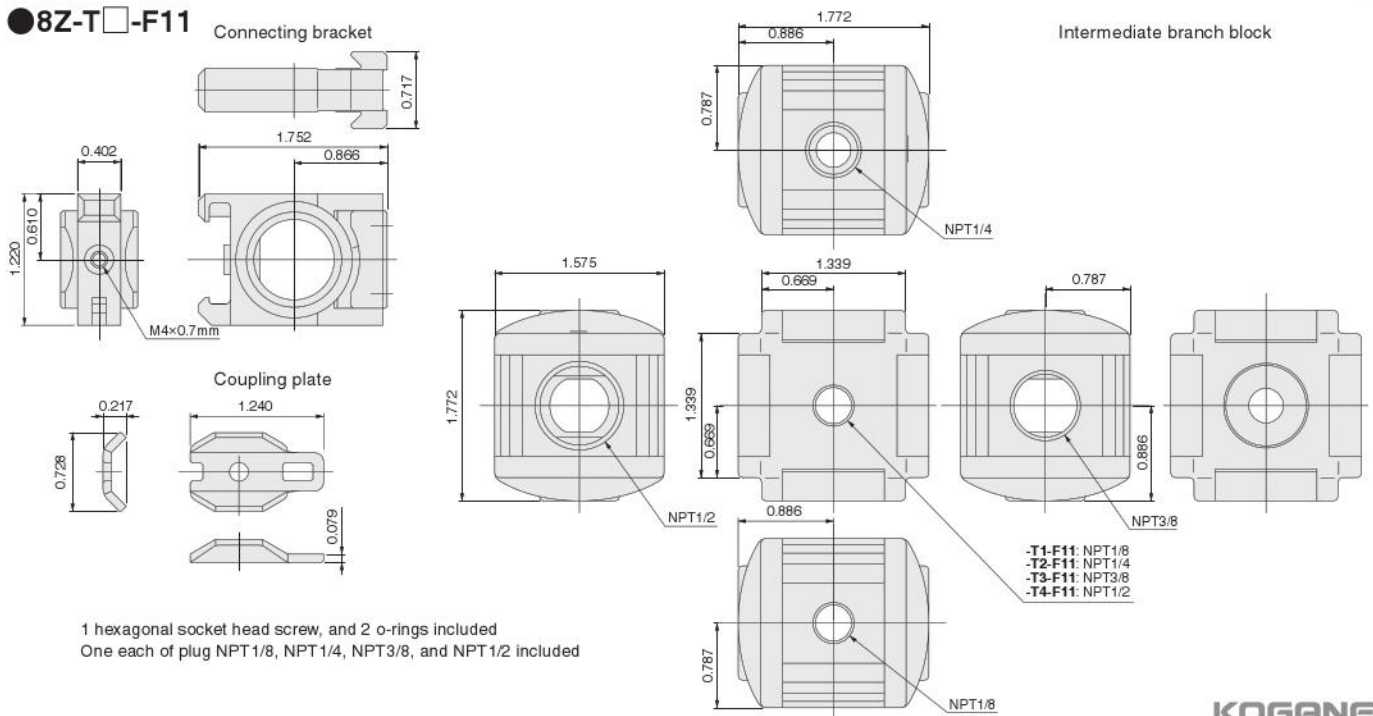

Module bracket dimensions in.

● 8Z-DP

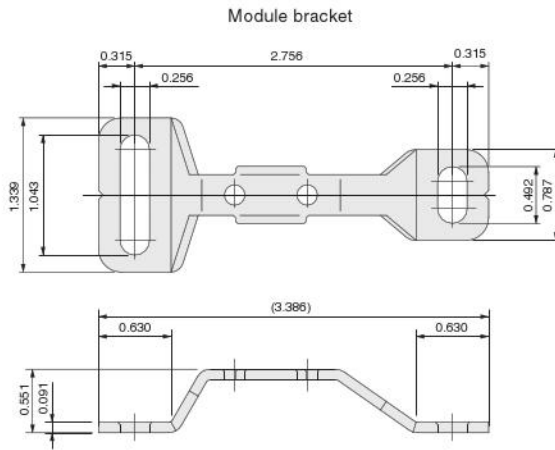

2 phillips head self-tapping screws
and 2 washers included

Coupling plate dimensions in.

● 8Z-FP

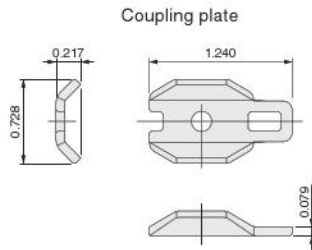

1 hexagonal socket screw included

Bracket



Bracket shape and applicable devices

Applicable model	Bracket model	Remarks	
Filter regulator	FRZ3□, FRZ4□, FRZ5□	8Z-BK	Option to support the product body.
Regulator	RZ3□, RZ4□, RZ5□	8Z-BK	Option to support the product body.
Residual pressure exhaust valve	50VZ	8Z-BV	Option to support the product body.

[Materials of major parts] Steel plate (electroless nickel plated)

Bracket dimensions in.

■ For filter regulators and regulators

● 8Z-BK

Bracket

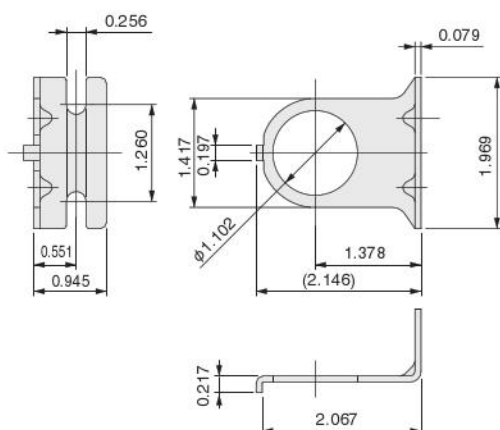

■ For residual pressure exhaust valve

● 8Z-BV

Bracket

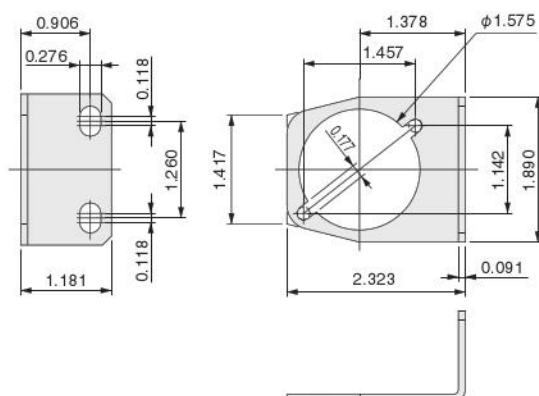

2 cross-head pan screws included

□ 1.181 in. integrated pressure gauge

G1C-30-F11·G4C-30-F11



● □ 1.181 in. integrated pressure gauge for FRZ series.

Symbol



Order codes

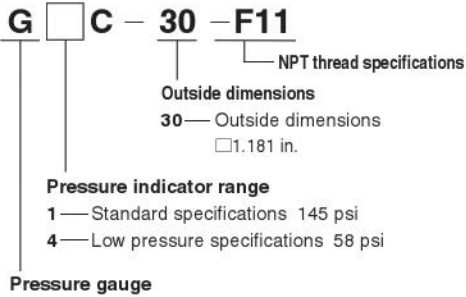

Specifications

Item	Model	G1C-30-F11	G4C-30-F11
Media		Air	
Connection method		O-ring seal, M3 × 0.5mm (secured by 2 screws)	
Maximum operating pressure	psi	145	58
Operating temperature range (atmosphere and media)	°F	41 to 140 (non-condensation)	
Pressure indicator range	psi	0 to 145	0 to 58
Display zone movable range	psi	0 to 145	0 to 58
Display zone maximum set range	psi	72.5	29
Accuracy (for atmosphere and medium at 41 to 95°F)		F.S. ±4%	F.S. ±6%
Materials of major parts	Case	Polybutylene terephthalate	
	Front cover	Polycarbonate	
	Bourdon tube	Brass	
Mass	oz	1.06	
Applicable models		FRZ3□-F11, FRZ4□-F11, FRZ5□-F11, RZ3□-F11, RZ4□-F11, RZ5□-F11	

Pressure gauge dimensions in.

G1C-30-F11

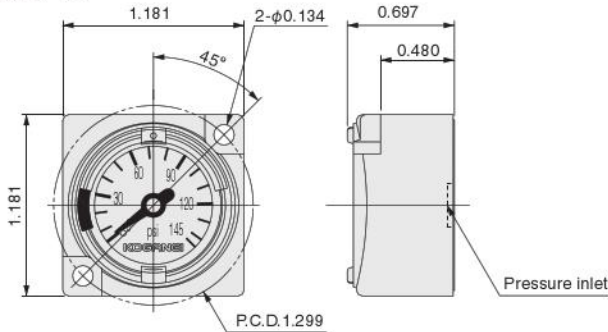

2 phillips head self-tapping screws and 1 o-ring included

G4C-30-F11

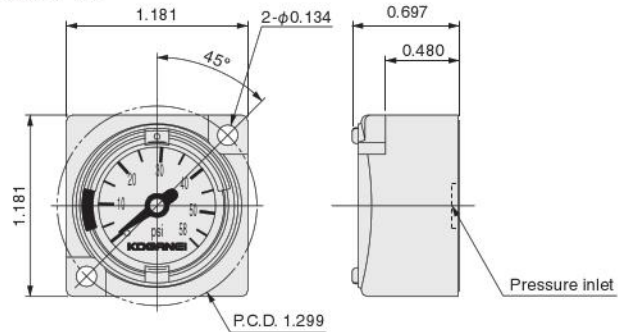

2 phillips head self-tapping screws and 1 o-ring included

Refer to page 15 regarding the handling instructions and precautions for the □ 1.181 in. integrated pressure gauge.

Pressure gauge

G1-40-F11·G3-40-F11

Symbol



Order codes

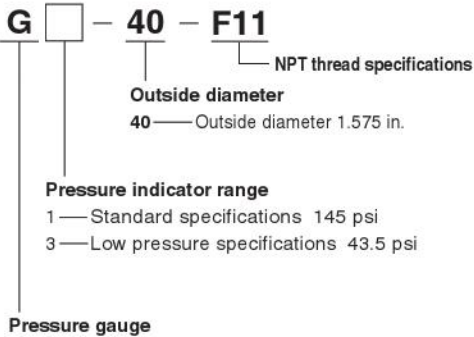

Specifications

Item	Model	G1-40-F11	G3-40-F11
Medium		Air	
Port size		NPT1/4 (M5 × 0.8)	
Pressure indicator range	psi	0 to 145	0 to 43.5
Accuracy		F.S. ± 3%	
Outside diameter	in	1.575	
Maximum operating pressure	psi	134.9	36.3
Operating temperature range (atmosphere and media)	°F	41 to 140 (non-condensation)	
Mass	oz	3.17	
Materials	Case	ABS	
	Connection port thread	Brass	
	Bourdon tube	Brass	

Pressure gauge dimensions in.

● G1-40-F11

● G3-40-F11

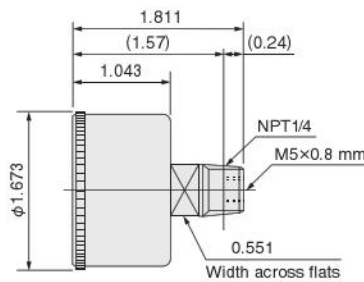
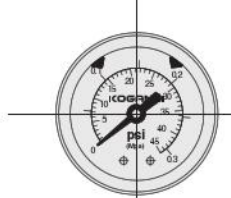
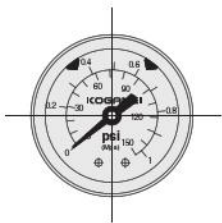

Handling instructions and precautions



NOTE The pressure gauge is a precision measuring device. Be careful of impacts and vibrations.

Mounting and piping

During mounting and piping operations, do not grab the pressure gauge body to tighten. For tightening, always use a wrench on the piping connection port's square portion. Use a tightening torque of 2.21 to 3.69 ft·lbf if the pressure gauges are mounted on the pressure port plate with NPT 1/4.

Preset marker

You can set the preset marker. Rotate the cover ring to first set the low pressure and then set the high pressure.

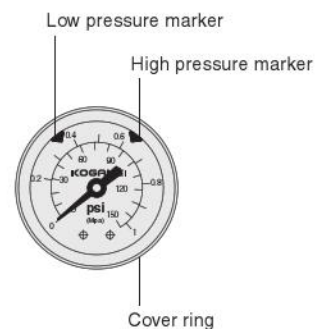

Pressure gauge

G1S-40-F11·G3S-40-F11

●Stainless steel Bourdon tube pressure gauge.

Symbol



Order codes

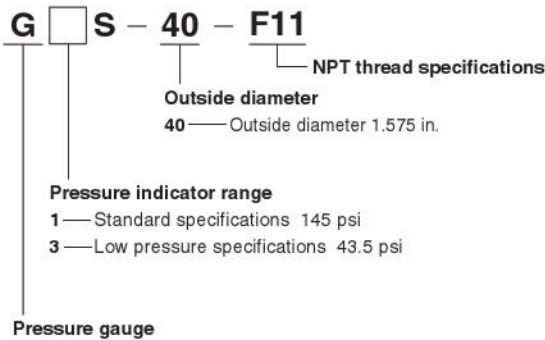

Specifications

Item	Model	G1S-40-F11	G3S-40-F11
Media		Air, N ₂ , O ₂ , CO ₂ , He, Ar	
Port size		NPT1/4	
Pressure indicator range	psi	0 to 145	0 to 43.5
Accuracy		F.S. ±2.5%	
Maximum operating pressure	psi	134.9	36.3
Operating temperature range	°F	41 to 140 (non-condensation)	
Mass	oz	3.21	

Materials

Name	Materials
Case	SPCC (painted black)
Connection port thread	SUS316
Bourdon tube	SUS316
Clear cover	Plastic (PC)

Pressure gauge dimensions in.

●G1S-40-F11

Standard specifications
145 psi

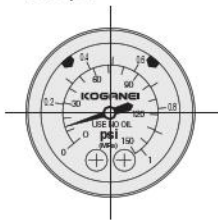

●G3S-40-F11

Low pressure specifications
43.5 psi

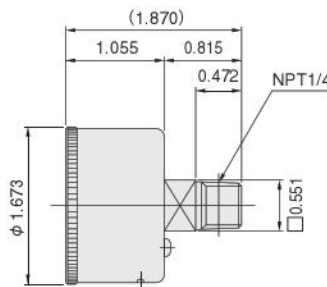
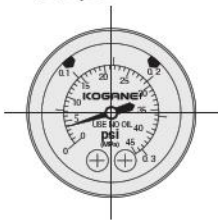

Handling instructions and precautions



NOTE The pressure gauge is a precision measuring device. Be careful of impacts and vibrations.

Mounting and piping

During mounting and piping operations, do not grab the pressure gauge body to tighten. For tightening, always use a wrench on the piping connection port's square portion. Use a tightening torque of 2.21 to 3.69 ft·lbf if the pressure gauges are mounted on the pressure port plate with NPT1/4.

Preset marker

You can set the preset marker. Rotate the cover ring to first set the low pressure and then set the high pressure.

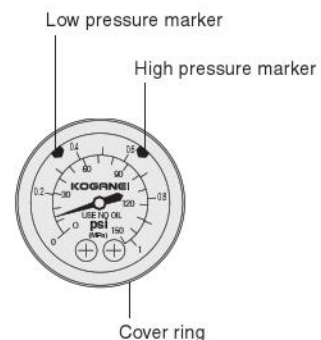

Digital pressure switch

GS620-3W



Specifications

Item	Type	Standard
	Model	High-pressure type GS620-3W
Indication of pressure		Gauge pressure
Rated pressure range		-14.5 to +145 psi
Pressure setting range		-14.5 to +145 psi
Proof pressure		218 psi
Applicable media		Non-corrosive gas
Supply voltage		12 to 24 VDC $\pm 10\%$, ripple P-P 10% or less
Power consumption		Normal operation: 720 mW or less (current consumption 30 mA or less at 24 V supply voltage) ECO mode (at STD): 480 mW or less (current consumption 20 mA or less at 24 V supply voltage), ECO mode (at FULL): 360 mW or less (current consumption 15 mA or less at 24 V supply voltage)
Comparative output		PNP transistor open collector <ul style="list-style-type: none"> • Maximum inflowing current: 100 mA • Applied voltage: 30 VDC or less (between comparative output and 0 V) • Residual voltage: 2 V or less (at inflowing current 100 mA, however, cable must be less than 78.7 in. long)
	Output operation	Selectable, either NO or NC by key operation
	Output mode	EASY mode/hysteresis mode/window comparator mode
	Response differential (hysteresis)	Minimum 1 digit (variable)
	Repeatability	$\pm 0.2\%$ F.S. (within ± 2 digits)
	Response time	2.5 ms, 5 ms, 10 ms, 25 ms, 50 ms, 100 ms, 250 ms, 500 ms, 1000 ms, 5000 ms, selectable by key operation
	Short circuit protection	Equipped
Display		4 digits + 4 digits, 3-color LCD display (display refresh rate: 250 ms, 500 ms, 1000 ms, selectable by key operation)
	Displayed pressure range	-14.5 to +145 psi
Indicators		Orange LED (comparative output 1 operation indicator, comparative output 2 operation indicator: Lights up when comparative output is ON)
Environmental resistance	Protective structure	IP40 (IEC)
	Ambient temperature	14 to 122 °F, in storage: 14 to 140 °F
	Ambient humidity	35 to 85% RH (however, no condensation or freezing), in storage: 35 to 85% RH
	Dielectric strength	1000 VAC for one minute (between electrical connection part and case)
	Insulation resistance	50 M Ω or over at 500 VDC meggers (between electrical connection part and case)
	Vibration resistance	Endurance 10 to 500 Hz, total amplitude 0.118 in, 2 hours in each of the XYZ directions (with panel mounting: Endurance 10 to 150 Hz, total amplitude 0.0295 in., 2 hours in each of the XYZ directions)
	Shock resistance	Endurance 328 ft/s ² (about 10 G), 3 times in each of the XYZ directions
Thermal characteristics		Within $\pm 1\%$ F.S. (reference at +68 °F)
Pressure port		M5x0.8 mm female thread and NPT1/8 male thread
Materials		Case: PBT (fiberglass reinforced), LCD display: Acrylic, pressure port: SUS303, mounting thread: brass (nickel plated), switches: silicon rubber
Connection method		Connectors
Wire length		Up to 328 ft long on a cable of 0.00047 in. ² or larger
Mass		Approximately 1.41 oz
Accessories		78.7 in. cable with connector: 1 pc.

Note: Unspecified measuring conditions use an ambient temperature of + 68 °F.

Handling instructions and Precautions



General precautions

Wiring

1. Always shut off the power supply before performing wiring work.
2. Confirm that the power source does not fluctuate over the rated power.
3. Be sure to ground to frame ground (F.G.) terminal of the power source when using a commercially available switching regulator.
4. When using equipment that could be sources of electric noise (such as switching regulators, inverter motors, etc.) near the pressure switch installation, be sure to ground the equipment's frame ground (F.G.) terminal.
5. Avoid wiring parallel to high voltage lines or power lines, or inside the same wiring conduits. Induction could cause erratic operation.
6. Incorrect wiring could cause malfunctions.
7. After completing wiring work, check to make sure that all connections are correct.

Connections

Do not apply stress directly to the connectors or to the wires coming out of the connectors.

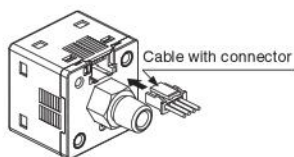

Mounting and piping

Use a tightening torque of 2.21 to 3.69 ft·lbf when mounting on the pressure port plate with NPT1/8. For details, see page 11 "Installing provided options".

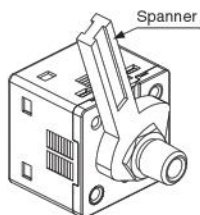

Other precautions

1. The GS6 series is for use with non-corrosive gases. Do not use with liquids or with corrosive gases.
2. Use within the rated pressure range.
3. Do not apply pressure in excess of the proof pressure. Doing so could damage the diaphragm and cause malfunctions.
4. Avoid using the product immediately after the power is turned on, while it is in a transitory state (about 0.5 sec).
5. Avoid use in very humid or dusty locations.
6. Be careful that the product does not come in direct contact with organic solvents, such as thinner, or water, oil, or grease.
7. Do not put pins or anything else in the pressure port. Doing so could damage the diaphragm and cause malfunctions.
8. Do not operate the keys with a pin or similar sharp object.

About the RUN mode

This is the normal operating mode.

Setting items	Description
Threshold value setting	You can directly change the ON/OFF threshold value by just pressing the UP key or DOWN key.
Zero adjust function	This function forces the pressure value to zero when the pressure port is open to the atmosphere.
Key lock function	This function prevents key operations.
Peak & bottom hold function	This function shows the peak and bottom values of changes in the pressure. The peak value appears in the main display, the bottom value appears in the sub display.

About the menu setting mode

1. While in the RUN mode, press and hold the mode switch key for 2 seconds to switch to the menu setting mode.
2. Press and hold the mode switch key while doing settings to switch to the RUN mode. When this is done, the items you changed are set.

Setting items	Description
Comparative output 1 output mode settings	Sets the output mode of comparative output 1.
Comparative output 2 output mode settings	Sets the output mode of comparative output 2.
NO/NC switching	Sets either normally open (NO) or normally closed (NC).
Response time setting	Sets the response time. Select a response time from 2.5 ms, 5 ms, 10 ms, 25 ms, 50 ms, 100 ms, 250 ms, 500 ms, 1000 ms, or 5000 ms.
Main display color switching	You can switch the color of the main display. Set red/green or green/red depending on whether output is ON/OFF. Also, you can set whether the normal color is red or green.
Unit switching (high-pressure type only)	You can switch the units for the pressure .

Remarks: See the instruction manual provided with the product for details about setting the modes, functions and values.

Input/output circuit and connections

Input/output circuit diagram

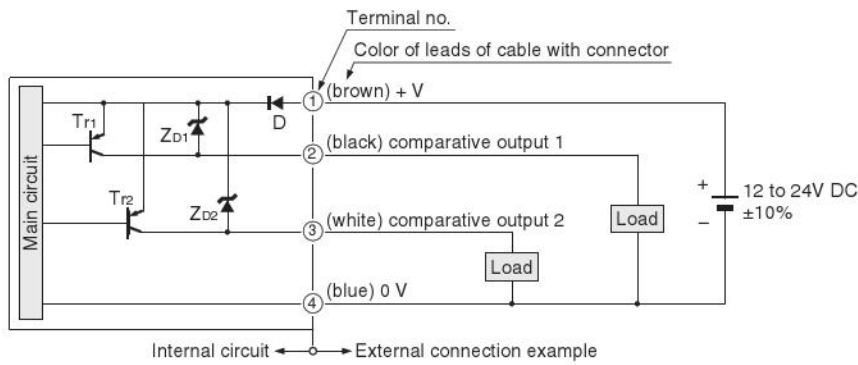

Code...D : Reverse current protection diode for power supply
 ZD1, ZD2 : Zener diodes for surge voltage absorption
 Tr1, Tr2 : PNP output transistor

Terminal layout

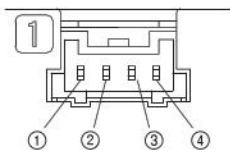

Terminal no.	Name
①	+V
②	Comparative output 1
③	Comparative output 2
④	0V

Order codes

GS6 20 - 3W

GS6 : Digital pressure switch
 20 : Operating pressure range
 20 : High-pressure type -14.5 to +145 psi
 3W : NPT thread specifications

Dimensions in.

GS620-3W

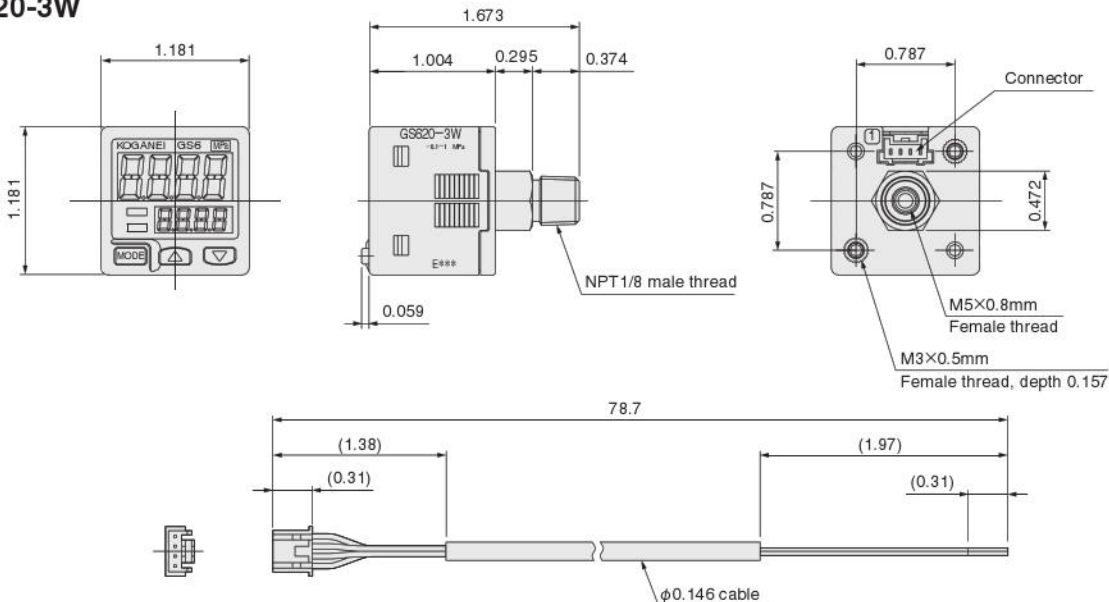

Pressure gauge with built-in switches

GS1-50-F11

- The set pressure and operating pressure are indicated on the same pressure gauge. Panel mounting offers convenient centralized control and management built into the control panel.
- An indicator is standard equipment, to check the switch operation state. Wiring connection methods offered include a standard grommet (lead wire) type, and a DIN connector type as an option.

Symbol

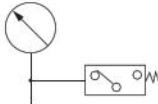

Order codes

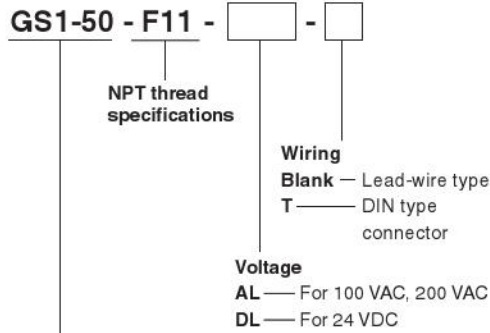

Pressure gauge with built-in switch
(outer diameter 1.969 in.)

Remarks: A model with built-in contact protection circuit (external surge absorption element) for AC is available. Contact your nearest Koganei sales office for details.

Specifications

Item	Model	GS1-50-F11-□-□	
Media		Air	
Maximum operating pressure	psi	120	
Pressure gauge specifications	Operating temperature range (atmosphere and media) °F	41 to 140	
	Pressure indicator range	psi	0 to 145
	Indicator accuracy		F.S. ±3%
Switch specifications	Pressure adjusting range	psi	14.5 to 120
	Regulating pressure indication error ^{Note 1 and Note 3}	psi	±7
	Repeatability ^{Note 3}	psi	±7 (41 to 113°F)
	Response differential	psi	10 or less
	Contact type		Micro switch a-contact (NO)
	Wiring	Standard	Lead wire Length: Approx. 19.7 in. (UL1007 AWG22)
	Options	DIN connector	
Indicator		Standard equipment: LED for DC, neon lamp for AC	
Shock resistance	G	1	
Mounting direction		Any	
Mass	oz	6.00 (with DIN connector 6.70)	
Materials	Body	Aluminum die-casting	
	Case	SPCC	
	Connection port thread	Brass	
	Bourdon tube	Brass	

- Notes 1: Shows when the pressure is rising.
 2: Use a set pressure that has a differential of at least 14.5 psi with the supply pressure.
 3: Regulating pressure indicator errors and repeatability errors could be accumulated. (maximum ±14.5 psi) Be careful during operations.

Micro switch rating

Rated voltage		A		
Operating current range		DC30V	AC125V	AC250V
Inductive load	Continuous	0.05 to 0.1	0.01 to 0.1	0.01 to 0.05
	Inrush	0.5 MAX.	0.5 MAX.	0.2 MAX.
Non-inductive load		0.01 to 0.5	0.01 to 0.3	0.01 to 0.2

Dimensions of pressure gauge with built-in switch in.

GS1-50-F11-□-□

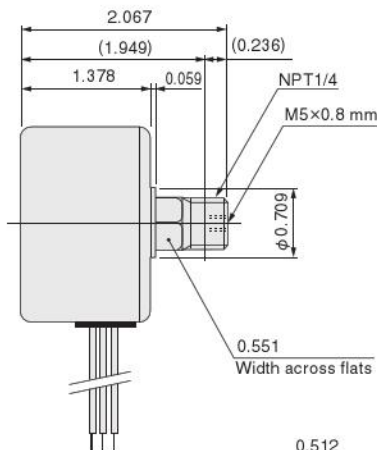
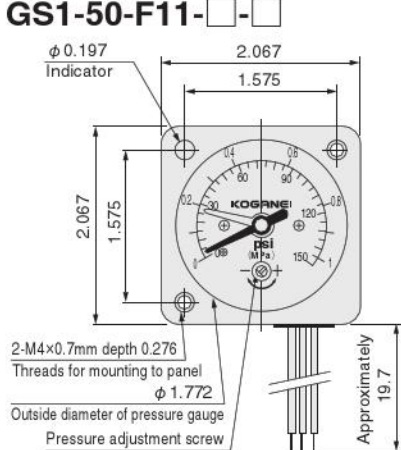

● DIN type connector

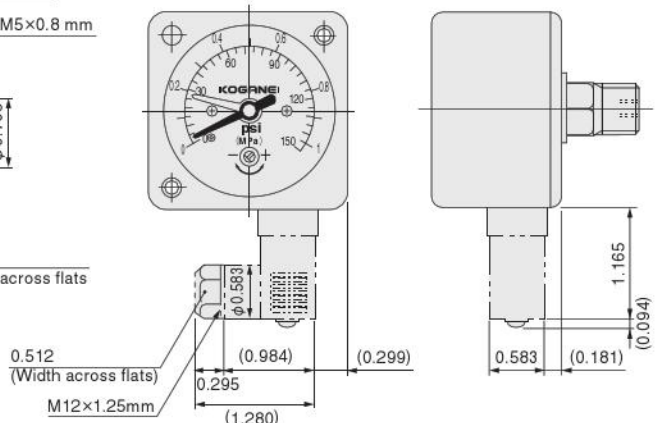

Handling instructions and Precautions



Pressure gauge with built-in switches

Mounting and piping

1. While any mounting direction is acceptable, install a throttle mechanism in cases where pressure pulsation is particularly severe, such as when mounted between a valve and an actuator. For mounting in locations subject to strong vibrations, consult us.
2. During mounting and piping operations, do not grab the pressure gauge body to tighten. For tightening, always use a wrench on the piping connection port hexagonal section. Use a tightening torque of 2.21 to 3.69 ft•lbf if the pressure gauges are mounted on the pressure port plate with NPT1/4.

Pressure regulation

Rotate the pressure adjustment screw, align the pressure regulation needle (red) to the set pressure, and set. Rotating the pressure adjustment screw to the left (counterclockwise) sets to a higher pressure, and rotating it to the right (clockwise) sets to a lower pressure. When the air pressure rises to the set pressure, the switch is activated, and when it falls to less than the setting pressure 10 psi (response differential), the switch is returned to the original state.

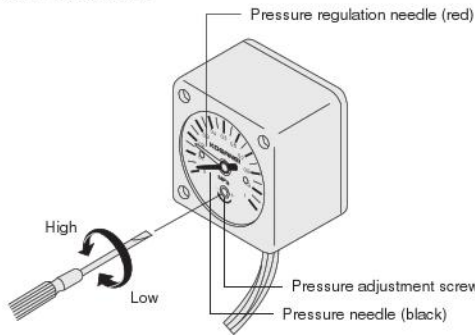

- NOTE**
1. To regulate the pressure, do not remove the cap on the lens surface, but insert a small screwdriver into a slit in the cap instead, and directly rotate the pressure adjustment screw.
 2. The pressure needle has an indication error of ± 7 psi. For fine-tuning adjustment, apply compressed air at the set pressure to check the switch triggering action.

Switch setting method and operations

Setting example: Want the switch to activate when the pressure is at 43.5 psi or less.

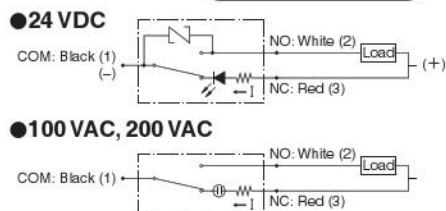
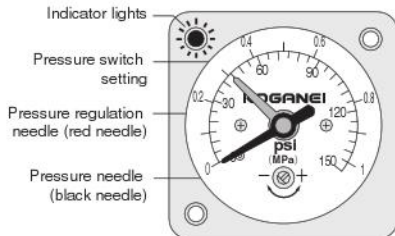

Set the pressure regulation needle (red needle) to 43.5 psi. When the pressure is in the range of 0 to 43.5 psi., the built-in switch remains at NC, as shown in the circuit diagram above, and the indicator lamp lights up.

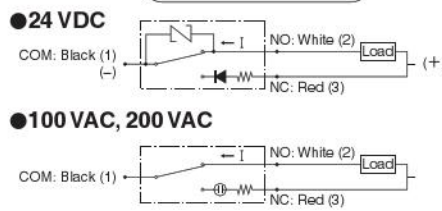
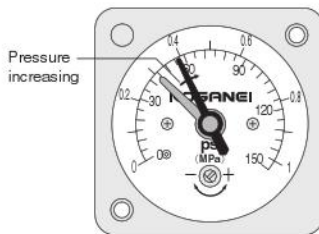

When the pressure supply increases, close to the pressure regulation needle (red needle), the built-in switch flips to NO, as shown in the circuit diagram above, the load current flows, and the indicator lamp goes out. The position at this time is A. At this time switching position A has a maximum 14.5 psi differential in relation to the pressure needle (black needle) because of a pressure needle tolerance of ± 7 psi and repeatability accuracy of ± 7 psi have accumulated.

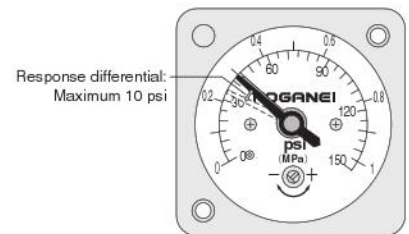

When the pressure falls, and the pressure needle (black needle) is higher than the pressure regulation needle (red needle), the internal switch changes to NC with a maximum response differential of 10 psi. When this happens, check the switching position and adjust the pressure regulation needle (red needle). Note that NC cannot be used as a load contact. Use the switching of NO to OFF by controlling a relay or other B-contact device.

General precautions

1. Use this product to check the supply pressure. For use in precision control circuits, consult us.
2. Switch performance may be degraded in installation locations where the temperature is higher than 113°F or where the humidity is constantly 50% or less. For use in these kinds of places, consult us.
3. If there is silicon gas in the ambient atmosphere, it may cause a contact failure because the contact operation uses micro switches. If there is silicon oil or silicon products in the vicinity of the product, eliminate the source of the silicon gas or use a contact protection circuit (for AC).

Wiring instructions

Pay attention to the NC and NO contacts and the colors of lead wires (in wires with connectors, the terminal numbers) for wiring. In the diagram below, the numbers in parentheses () represent the terminal numbers, while the \uparrow shows the direction of rising pressure. The indicator lamp switches off when the value is at the set pressure or higher, and lights up as a warning when the value falls below the set pressure.

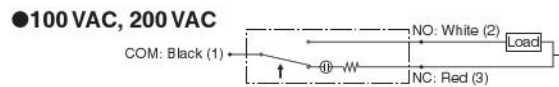
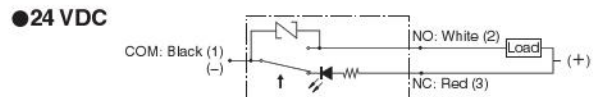

Wiring instructions with DIN connector

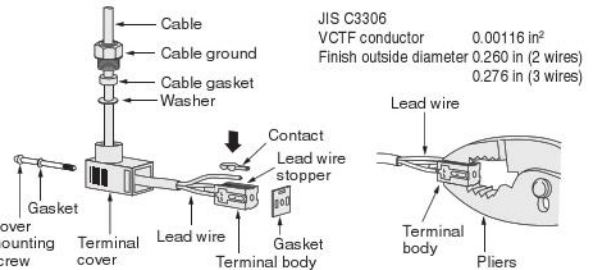

When peeling off the sheath (for cable sheath only), pay attention to the lead wire bending direction. Setting the outer lead wires inside the terminal cover to be about 0.31 in longer than the inner wires can make it easier to mount the terminal body onto the terminal cover. Without peeling off their insulations, insert the lead wires into the terminal body until they bump up against the lead wire stopper, lower the contact from above to the lead wire, and use pliers to push them into firm contact, so that the contacts are touching the core wire.

NOTE For the connector type, the connector wiring position at time of delivery is in the connecting thread side (back side).

Limited Warranty

KOGANEI CORP. warrants its products to be free from defects in material and workmanship subject to the following provisions.

Warranty Period The warranty period is 180 days from the date of delivery.

Koganei Responsibility If a defect in material or workmanship is found during the warranty period, KOGANEI CORP. will replace any part proved defective under normal use free of charge and will provide the service necessary to replace such a part.

Limitations

- This warranty is in lieu of all other warranties, expressed or implied, and is limited to the original cost of the product and shall not include any transportation fee, the cost of installation or any liability for direct, indirect or consequential damage or delay resulting from the defects.

- KOGANEI CORP. shall in no way be liable or responsible for injuries or damage to persons or property arising out of the use or operation of the manufacturer's product.

- This warranty shall be void if the engineered safety devices are removed, made inoperative or not periodically checked for proper functioning.

- Any operation beyond the rated capacity, any improper use or application, or any improper installation of the product, or any substitution upon it with parts not furnished or approved by KOGANEI CORP., shall void this warranty.

- This warranty covers only such items supplied by KOGANEI CORP. The products of other manufacturers are covered only by such warranties made by those original manufacturers, even though such items may have been included as the components.

The specifications are subject to change without notice.

Related catalogs

URL <http://www.koganei.co.jp>

E-mail: overseas@koganei.co.jp



KOGANEI CORPORATION

OVERSEAS DEPARTMENT

3-11-28, Midori-cho, Koganei City, Tokyo 184-8533, Japan
Tel: 81-42-383-7271 Fax: 81-42-383-7276

KOGANEI INTERNATIONAL AMERICA, INC.

39300 Civic Center Dr., Suite 280, Fremont, CA 94538, U.S.A.
Tel: 1-510-744-1626 Fax: 1-510-744-1676

SHANGHAI KOGANEI INTERNATIONAL TRADING CORPORATION

Room 2606-2607, Tongda Venture Building No.1, Lane 600, Tianshan Road,
Shanghai, 200051, China
Tel: 86-21-6145-7313 Fax: 86-21-6145-7323

TAIWAN KOGANEI TRADING CO., LTD.

Rm. 2, 13F, No88, Sec. 2, Zhongxiao E. Rd., Zhongzheng Dist., Taipei City 100,
Taiwan (ROC)
Tel: 886-2-2393-2717 Fax: 886-2-2393-2719

KOGANEI KOREA CO., LTD.

6F-601, Tower Bldg., 1005, Yeongdeong-dong, Giheung-gu, Yongin-si, Gyeonggi-do,
446-908, Korea
Tel: 82-31-246-0414 Fax: 82-31-246-0415

KOGANEI (THAILAND) CO., LTD.

3300/90, Tower B, Elephant Tower, 16th Fl., Phaholyothin Road, Chomphon,
Chatuchak, Bangkok 10900, Thailand
Tel: 66-2-937-4250 Fax: 66-2-937-4254

KOGANEI ASIA PTE. LTD.

69 Ubi Road 1, #05-18 Oxley Bizhub, Singapore 408731
Tel: 65-6293-4512 Fax: 65-6293-4513



Introducing the iB-Cyclone, a high-speed cyclone type drain separator that incorporates the best of centrifugal separation know-how.

**iB-Cyclone
NPT thread
specifications
Catalog No. BK-E007**



FRZ Series and iB-Cyclone can be used in combination. (Except for FRZ3□, and RZ3□)

Contact the sales department at Koganei sales office or Koganei overseas department for more information.