



KOGANEI

VALVES GENERAL CATALOG

SOLENOID VALVES 200 SERIES INDEX

SOLENOID VALVES 200 SERIES

Features	159
Basic Models and Configuration	159
Specifications	161
Solenoid Valve Order Codes	163
Manifold Order Codes	164
Operating Principles and Symbols	165
Dimensions of Solenoid Valve	166
Dimensions of Manifold	167
Dimensions of Options	170
Sub-base Regulator	171
Handling Instructions and Precautions	172

 **Caution** Before use, be sure to read the "Safety Precautions" on p. 31.

The standard for square and direct acting types

Solenoid Valves 200 Series

Offers reliable control of $\phi 32$ [1.260in.]~
 $\phi 80$ [3.150in.] bore size air cylinders.
 Standard direct acting solenoid valve
 offers a refined inner construction
 and versatility with excellent reliability and
 durability, responding with ease of use
 and flexibility to its "reliable operation"
 feature.





- The sealing method uses a pressure-balanced poppet for balancing supply pressure at the valve seat portion. Low power consumption translates to optimum performance for high cycle applications, and the valve is compact but large flow.
- An overspring mechanism prevents excessive force from being applied on the seal. It demonstrates excellent durability.
- The single solenoid 2-, 3-, 5-port valves offer assured operations even under low pressure. They demonstrate multiple performance capabilities as a low pressure specification actuator operation, selector valve, or divider valve.
- A flywheel diode is standard equipment for the AC solenoid (optional for the DC24V). Eliminates solenoid burning and humming.
- Responds to diversified needs. Wide selection of options.

2-, 3-port Valves Valve Functions and Connection Port Configurations

		De-energized	Energized
2-port	Normally closed (NC)		
	Normally open (NO)		
3-port	Normally closed (NC)		
	Normally open (NO)		
Selector valve			
Divider valve			

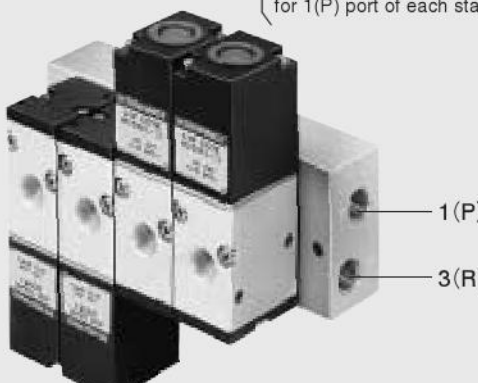
200 Series Single Unit Basic Models and Configuration

2-, 3-port	5-port				
	2-position		3-position		
	Single solenoid	Double solenoid	Closed center	Exhaust center	Pressure center
200E1	200-4E1	200-4E2	203-4E2	203-4E2-13	203-4E2-14

Manifold for 2-, 3-port valves	Manifold for combination mounting of 2-, 3-, 5-port valves
<p>BM□T—T type (1(P), 3(R)) manifold BM□C—C type (1(P), 3(R)) manifold</p> <p>Made to order. Built-in check mechanism for 1(P) port of each station.</p>  <p>1 (P) 3 (R)</p>	<p>BM□F—F type (1(P), 3(R2), 5(R1)) manifold</p>  <p>5 (R1) 1 (P) 3 (R2)</p>
Manifold for combination mounting of 2-, 3-, 5-port valves	
<p>BM□U—U type (1(P)) manifold</p>  <p>1 (P)</p>	<p>BM□L—L type (1(P)) manifold</p>  <p>1 (P)</p>
Manifold for 5-port valves only	
<p>BM□A—A type (all port) manifold</p>  <p>5 (R1) 1 (P) 3 (R2)</p>	

SOLENOID VALVES

200 SERIES

Basic Models and Functions

Item	Basic model	200E1 (M200E1 ^{Note})	200-4E1	200-4E2	203-4E2
	Direct piping, T, C, F, U, L type manifolds				
	A type manifold	—	A200-4E1	A200-4E2	A203-4E2
Number of positions			2 positions		3 positions
Number of ports	2, 3 ports		5 ports		
Valve function	Normally closed (NC) or Normally open (NO)		Single solenoid	Double solenoid	Closed center (standard), exhaust center or pressure center (option)

Remark: For optional specifications and order codes, see p.163~164.

Note: **M200E1** is a dedicated valve for the manifold. For details, see "About M200E1" on p.163.

Specifications

Item	Basic model	200E1 (M200E1)	200-4E1	200-4E2	203-4E2
	Direct piping, T, C, F, U, L type manifolds				
	A type manifold	—	A200-4E1	A200-4E2	A203-4E2
Media	Air				
Operation type	Direct acting type				
Effective area [Cv]	mm ²	8.5 [0.47]	7.5 [0.42]		6.5 [0.36]
Port size	Rc1/4				
Lubrication	Not required				
Operating pressure range	MPa [kgf/cm ²] [psi.]	0~0.9 {0~9.2} [0~131]		0.15~0.7 {1.5~7.1} [22~102]	0~0.7 {0~7.1} [0~102]
Proof pressure	MPa [kgf/cm ²] [psi.]	1.35 [13.8] [196]		1.05 [10.7] [152]	
Response time ^{Note} ms	DC24V	20/20 or below		20 or below	20/20 or below
	ON/OFF AC100V, AC200V	20/20 or below		20 or below	20/20 or below
Maximum operating frequency	Hz	5			
Minimum time to energize for self holding	ms	—		50	—
Operating temperature range (atmosphere and media)	°C [°F]	0~50 [32~122]			
Shock resistance m/s ² [G]	Lateral direction	980.7 [100.0]			
	Axial direction	588.4 [60.0]	392.3 [40.0]	294.2 [30.0]	588.4 [60.0]
Mounting direction	Any				

Note: Values when air pressure is 0.5MPa [5.1 kgf/cm²] [73psi.]. Values for □200-4E2 are switching time from the opposite-side position, and for □203-4E2 are switching time from the neutral valve position.

Solenoid Specifications

Item	Rated voltage	DC24V	AC100V		AC200V	
	Type	DC type	Flywheel diode type			
Operating voltage range	V	21.6~26.4 (24 ± 10%)	90~110 (100 ± 10%)		180~220 (200 ± 10%)	
Current ^{Note 1} (when rated voltage is applied)	Frequency	—	50	60	50	60
	Energizing ^{Note 2} mA(r.m.s)	420 (10.1W) [432 (10.4W)]	160 [170]	150 [160]	70 [72]	65 [68]
Maximum allowable leakage current	mA	30	15		7	
Insulation resistance	MΩ	10				
Wiring type and lead wire length	Standard	Grommet type: 300mm [11.8in.]				
	Optional	With DIN connector				
Color of lead wire		Red [Red (+), Blue (-)] ^{Note 1} Red (+), Black (-) ^{Note 3}	Yellow, Black		White, Black	
Color of LED indicator (optional)		Red	Yellow		Green	
Surge suppression	Standard	—				
	Optional	Flywheel diode	Flywheel diode ^{Note 4}			

Notes: 1. Figures and descriptions in brackets [] are for solenoids with LED indicators.

2. Since the AC types have built-in flywheel diodes, the starting current value and energizing current value are virtually the same.

3. For solenoids with surge suppression, and solenoids with surge suppression and LED indicators.

4. Since the AC types have built-in flywheel diodes, they are sometimes not turned on by the solid-state relay (SSR) with zero-cross function.

For this reason, use it only after confirming the solid-state relay's ratings and precautions.

Manifold Port Size

Manifold model	Port	Location of piping port	Port size
BM□T BM□C	1(P)	Manifold	Rc 1/4
	2(A)	Valve	
	3(R)	Manifold	
BM□F	1(P)	Manifold	Rc 1/4
	4(A), 2(B)	Valve	
	3(R2), 5(R1)	Manifold	
BM□U	1(P)	Manifold	Rc 1/4
	4(A), 2(B)	Valve	
	3(R2), 5(R1)	Valve	
BM□L	1(P)	Manifold	Rc 1/4
	4(A), 2(B)	Valve	
	3(R2), 5(R1)	Valve	
BM□A	1(P)	Manifold	Rc 1/4
	4(A), 2(B)		
	3(R2), 5(R1)		

Solenoid Valve Mass

g [oz.]

Basic model	Mass
200E1	300 [10.58]
M200E1	300 [10.58] ^{Note}
200-4E1	330 [11.64]
200-4E2	520 [18.34]
203-4E2	500 [17.64]
A200-4E1	330 [11.64]
A200-4E2	520 [18.34]
A203-4E2	525 [18.52]

Note: Sub-plate not included. For sub-plate mass, see p.167.

Manifold Mass

g [oz.]

Manifold model	Mass calculation of each unit (n=number of units)	Block-off plate
BM□T	(138×n)+125 [(4.87×n)+4.41]	30 [1.06]
BM□C	(138×n)+125 [(4.87×n)+4.41]	30 [1.06]
BM□F	(163×n)+175 [(5.75×n)+6.17]	42 [1.48]
BM□U	(50×n)+200 [(1.76×n)+7.05]	15 [0.53]
BM□L	(50×n)+200 [(1.76×n)+7.05]	15 [0.53]
BM□A	(145×n)+150 [(5.11×n)+5.29]	42 [1.48]

Cylinder Operating Speed

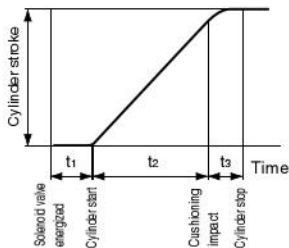

To obtain the time required for the cylinder to complete 1 stroke, add the cylinder's delay time t_1 (time between energizing of the solenoid valve and actual starting of the cylinder), to the cylinder's max. operating speed time t_2 . When a cushion is used, add the cushioning time t_3 to the above calculations. The standard cushioning time t_3 is approximately 0.2 seconds.

Maximum operating speed

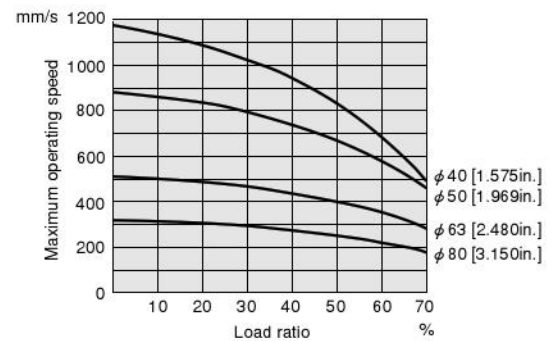

200-4E1, 200-4E2

Measurement conditions

- Air pressure: 0.5MPa [5.1kgf/cm²] [73psi.]
- Piping inner diameter and length: φ6×600mm (Bore size φ32, φ40)
φ8×1000mm (Bore size φ50~φ80)
- Fitting: Quick fitting TS8-02(TS12-02, TS12-04)
- Load ratio = $\frac{\text{Load}}{\text{Cylinder theoretical thrust}}$ (%)
- Cylinder stroke: 300mm [11.8in.]

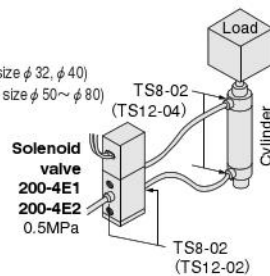

Delay time

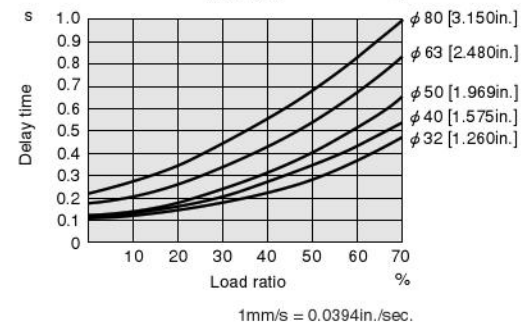

Flow Rate

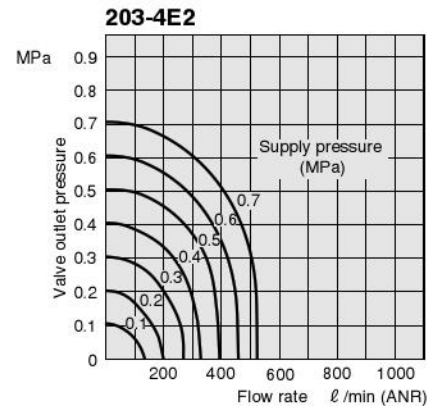
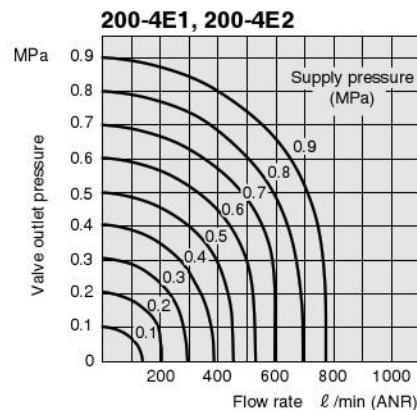
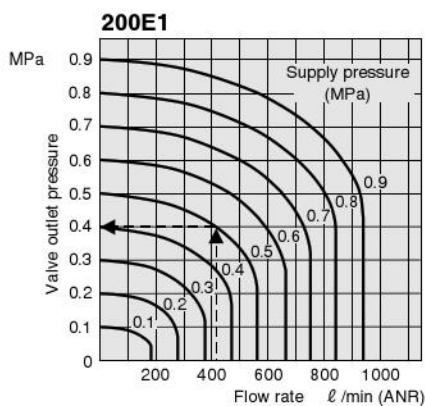

How to read the graph

When the supply pressure is 0.5MPa [73psi.] and flow rate is 415 l/min [14.6ft³/min.] (ANR), the valve outlet pressure becomes 0.4 MPa [58psi.].

1MPa = 145psi., 1 l/min = 0.0353ft³/min.

200 Series Solenoid Valve Order Codes

2-, 3-port valve Number of ports	2-, 3-port valve Valve function	3-position valve Valve function	Mounting base	Wiring type	Speed controller	LED Indicator	Flywheel diode
3-port Blank	Normally closed (NC) Blank	Closed center Blank	Without mounting base Blank	Grommet type Blank	Without speed controller Blank	Without LED indicator Blank	With flywheel diode Blank
2-port -2	Normally open (NO) ^{Note} -11	Exhaust center -13	With mounting base -21	DIN connector -39	With speed controller -70	With LED indicator -L	With flywheel diode -SR
	Note: When using as a normally open (NO) single unit, see the 2-, 3-port valves valve functions and connection port configurations on p.159.	Pressure center -14					

	Basic model								Voltage	
Direct piping	2-, 3-port single solenoid	200E1	-2 ^{Note 3}	-11 ^{Note 2}	-21	-39	-70	-L	-SR	DC24V AC100V AC200V
	5-port single solenoid	200-4E1								
	5-port double solenoid	200-4E2								
	5-port 3-position	203-4E2			-13 -14					
For manifold only ^{Note 1}	2-, 3-port single solenoid	M200E1	-2	-11						DC24V AC100V AC200V
	5-port single solenoid	A200-4E1								
	5-port double solenoid	A200-4E2								
	5-port 3-position	A203-4E2			-13 -14					

Notes : 1. Cannot be used as a single unit.
 2. For 2-port only. Always enter **200E1-2-11**. For the 3-port, supplying air through the 3(R) port and exhausting through the 1(P) port makes it possible to use as a normally open (NO) type valve.
 3. A plug is included. Always install it in position before use.

- **M200E1** includes a sub-plate for mounting on the F type manifold, gaskets, and mounting screws.
- When ordering the non-ion specification, enter **-NCU** after the basic model code.
- Not available with DIN connector
- For DC24V only. For AC100V and AC200V, equipped as standard.

Manifold Models and Applicable Valves Basic Models

Valve specification Manifold model	2-, 3-port		5-port		
	Single solenoid	Double solenoid	Single solenoid	Double solenoid	3-position
BM□T	200E1				
BM□C ^{Note}	M200E1-11				
BM□F	M200E1 M200E1-11	200-4E1	200-4E2	203-4E2	
BM□U	200E1	200-4E1	200-4E2	203-4E2	
BM□L	M200E1-11				
BM□A		A200-4E1	A200-4E2	A203-4E2	

Note: **BM□C** is made to order.







● About M200E1

M200E1 is a dedicated valve for the manifold. Differences with **200E1** are as shown in the table below.

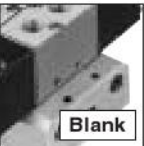
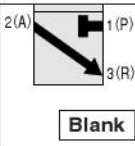
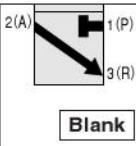
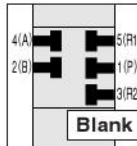
Model	Point of difference	Remarks
M200E1	With sub-plate ^{Note}	For F type manifold only
M200E1-11	With sub-plate ^{Note} Port location	For T, C, F, U, L type manifolds

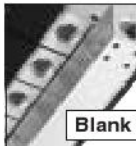
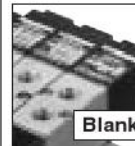
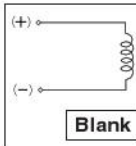
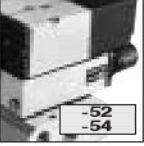
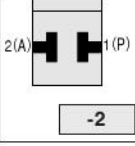
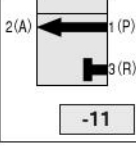
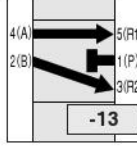
Note: The sub-plate is only used for mounting on F type manifolds. For details, see p.167.

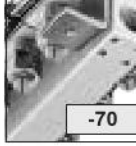
200 Series Manifold Order Codes

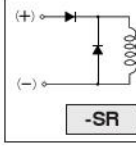
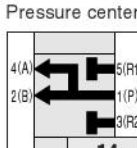



Sub-base regulator	2-, 3-port valve Number of ports	2-, 3-port valve Valve function	3-position valve Valve function	Wiring type	Speed controller	LED Indicator	Flywheel diode
Without sub-base regulator  Blank	3-port  Blank	Normally closed (NC)  Blank	Closed center  Blank	Grommet type  Blank	Without speed controller  Blank	Without LED indicator  Blank	Without flywheel diode  Blank
With sub-base regulator  -52 -54	2-port  -2	Normally open (NO)  -11	Exhaust center  -13	DIN connector  -39	With speed controller  -70	LED indicator  -L	With flywheel diode  -SR
			Pressure center  -14				

Manifold model Number of units	Station	Basic model					Voltage	
BM	T C	stn. □	-200E1	-2	-39	-L	DC24V AC100V AC200V	
		stn. □	-M200E1 <small>Note</small>	-2	-11	-39	-L	DC24V AC100V AC200V
	F	stn. □	-M200E1 <small>Note</small>	-2	-11	-39	-L	DC24V AC100V AC200V
		stn. □	-200-4E1			-39	-L	DC24V AC100V AC200V
		stn. □	-200-4E2			-39	-L	DC24V AC100V AC200V
	U L	stn. □	-200E1	-2	-11	-39	-L	DC24V AC100V AC200V
		stn. □	-M200E1 <small>Note</small>	-2	-11	-39	-L	DC24V AC100V AC200V
		stn. □	-200-4E1			-39	-L	DC24V AC100V AC200V
		stn. □	-200-4E2			-39	-L	DC24V AC100V AC200V
	A	stn. □	-203-4E2			-39	-L	DC24V AC100V AC200V
		stn. □	-A200-4E1	-52		-39	-L	DC24V AC100V AC200V
		stn. □	-A200-4E2	-54		-39	-L	DC24V AC100V AC200V

- BM □ C is made to order.
- Valve mounting location from the left-hand side when facing the 4(A), 2(B) ports.
- Specify the valve type for each station.
- Enter -BP when closing a station with a block-off plate without mounting a valve.
- When ordering the non-ion specification, enter -NCU after the basic model code.
- For details, see p.171.
- For DC24V only. For AC100V and AC200V, equipped as standard.
- Not available with DIN connector

Note: -M200E1 should be used in the normally open (optional code: -11) type only.

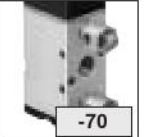
Options

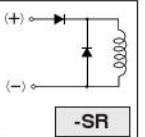
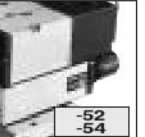
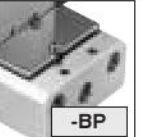
Mounting base  -21 ● For direct piping ● Not available with double solenoid	DIN connector  -39 ● Cannot be used with -L	Speed controller  -70	Built-in LED indicator  -L	Built-in flywheel diode  -SR ● Only for DC24V	Sub-base regulator  -52 -54 ● For BM □ A manifold only ● -52: 1(P) port pressure regulating ● -54: 2(B) port pressure regulating	Block-off plate  -BP
---	--	---	--	--	---	--

Operating Principles and Symbols

3-port

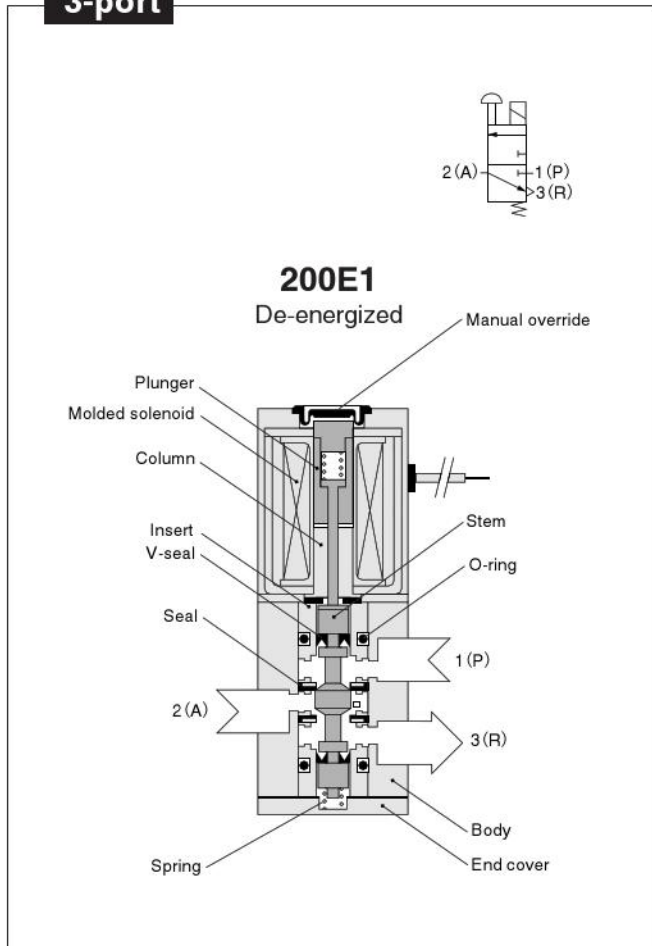

5-port, 2-position

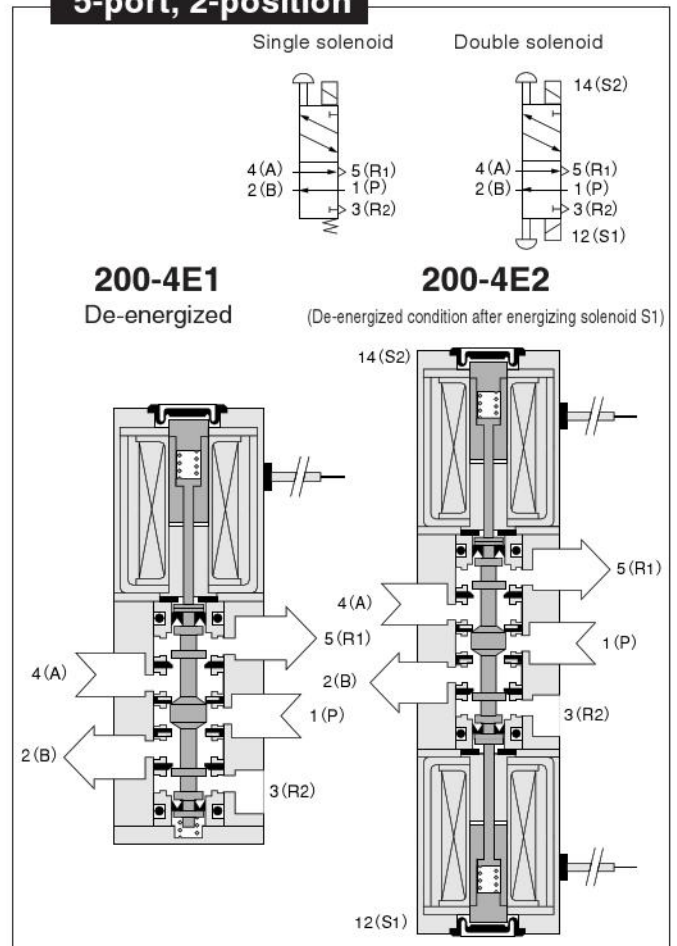

Major Parts and Materials

	Parts	Materials
Valve	Body	Aluminum alloy
	Stem	(anodized)
	Seal	Synthetic rubber
	Insert	Aluminum alloy and brass
	Spring	Stainless steel
	Mounting base	Mild steel (zinc plated)
Manifold	Plunger	Magnetic stainless steel
	Column	Magnetic steel (zinc plated)
	Body	Aluminum alloy (anodized)
	Block-off plate	Mild steel (zinc plated)
	Seal	Synthetic rubber
	Mounting bracket	Mild steel (zinc plated)

Remark: Materials that generate copper ions are not used for the non-ion specification.

5-port, 3-position

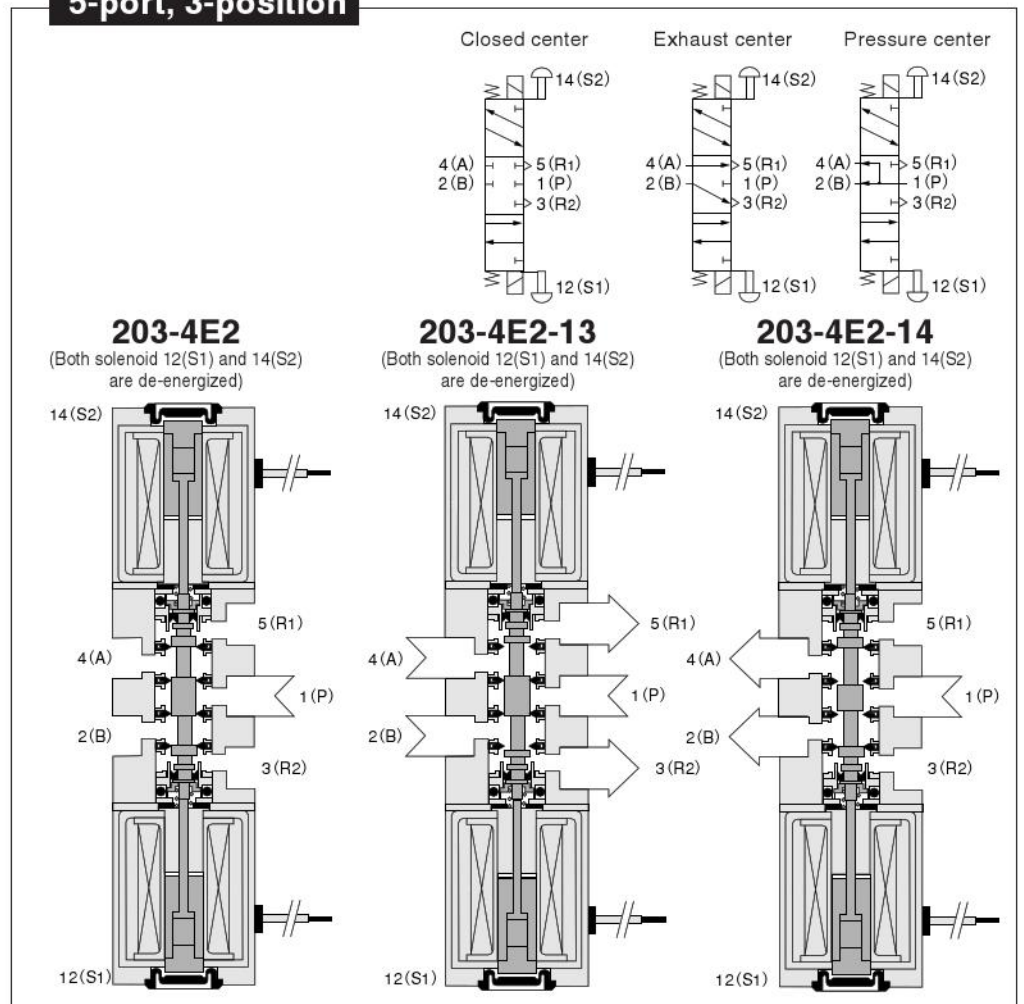

Dimensions of Solenoid Valve (mm)

2-, 3-port

200E1

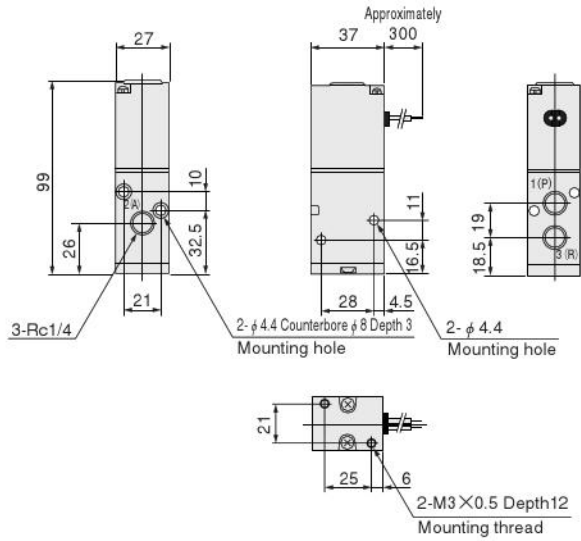

5-port, 2-position

200-4E1

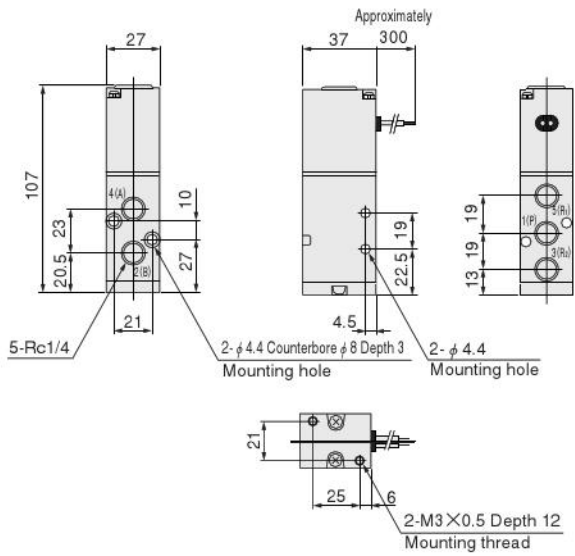

200-4E2

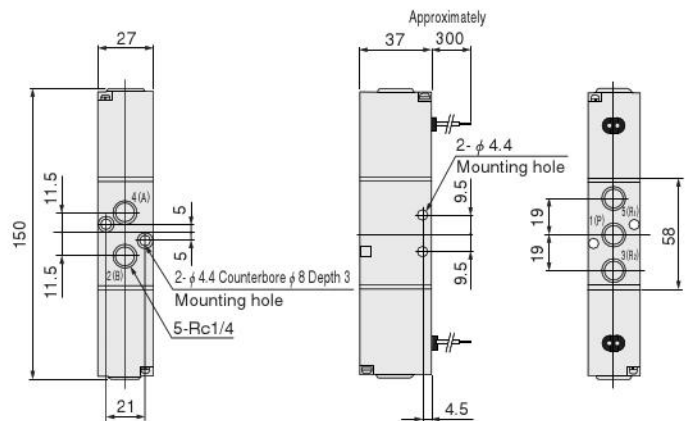

5-port, 3-position

203-4E2

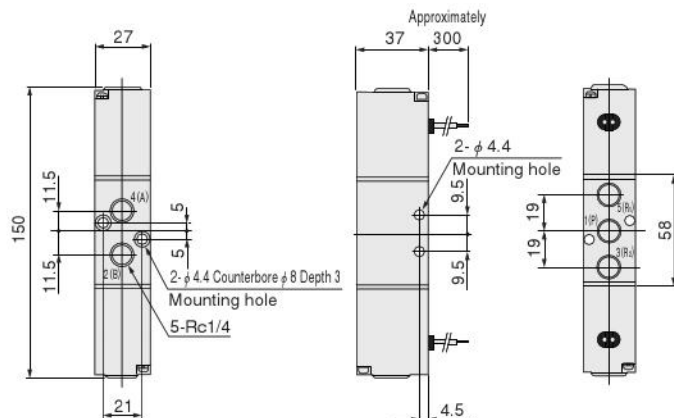

For options, see p.170.

Dimensions of Manifold (mm)

For 2-, 3-port

BM□T
BM□C

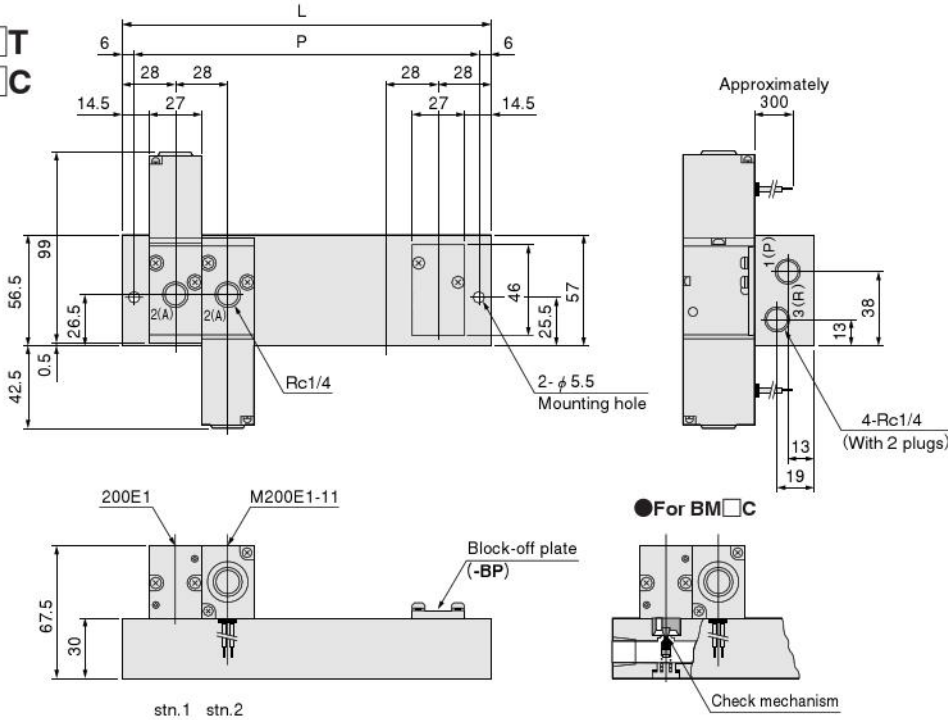

Unit dimensions

Model		L	P
BM2T	BM2C	84	72
3T	3C	112	100
4T	4C	140	128
5T	5C	168	156
6T	6C	196	184
7T	7C	224	212
8T	8C	252	240
9T	9C	280	268
10T	10C	308	296

For combination mounting of 2-, 3-, 5-port

BM□F

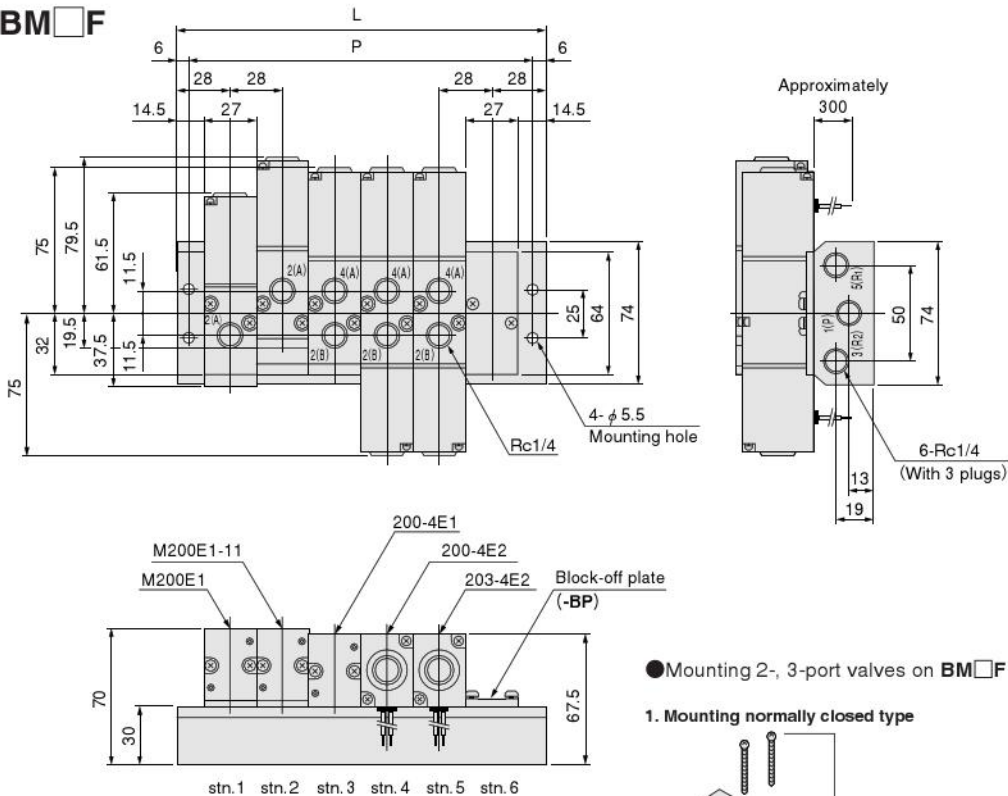

Unit dimensions

Model		L	P
BM2F		84	72
3F		112	100
4F		140	128
5F		168	156
6F		196	184
7F		224	212
8F		252	240
9F		280	268
10F		308	296

For options, see p.170.

Dimensions of Manifold (mm)

For combination mounting of 2-, 3-, 5-port

BM□U

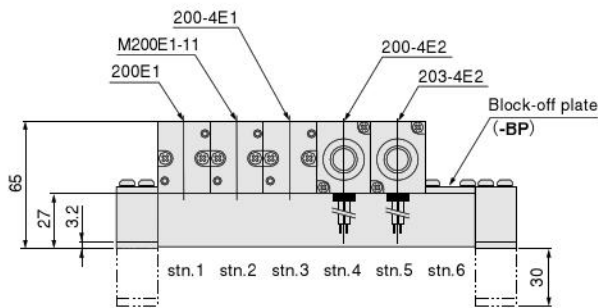
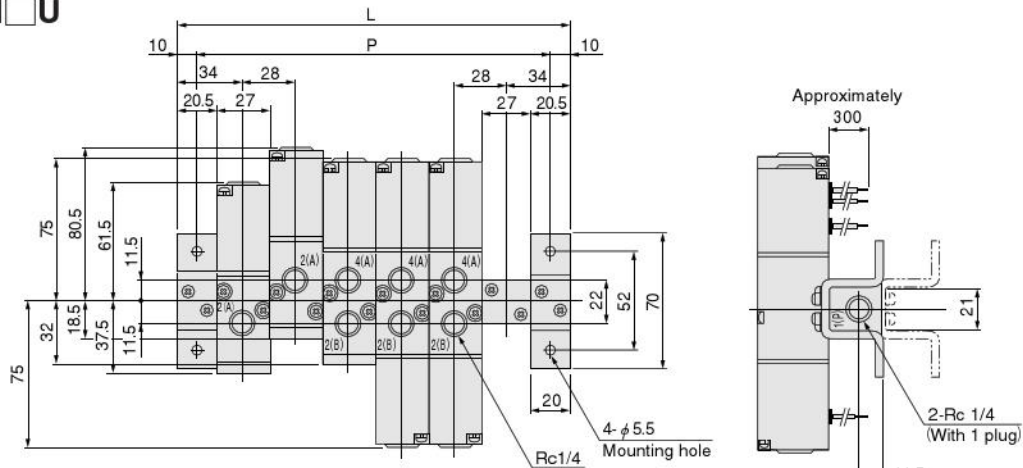

Unit dimensions

Model	L	P
BM2U	96	76
3U	124	104
4U	152	132
5U	180	160
6U	208	188
7U	236	216
8U	264	244
9U	292	272
10U	320	300

BM□L

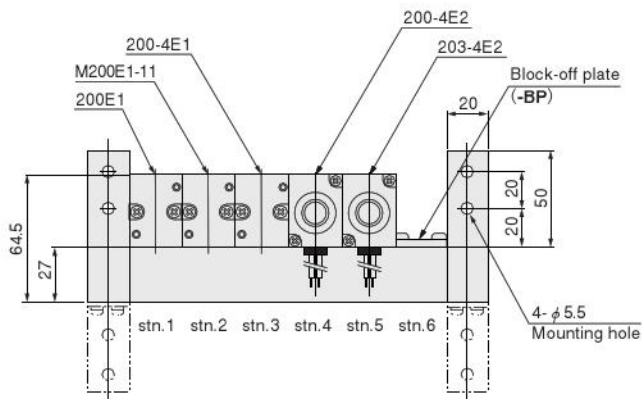
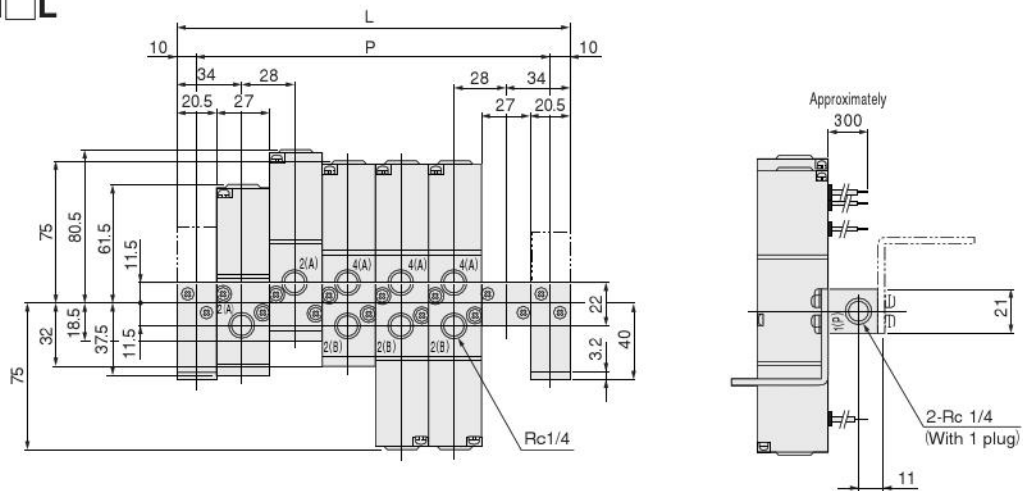

Unit dimensions

Model	L	P
BM2L	96	76
3L	124	104
4L	152	132
5L	180	160
6L	208	188
7L	236	216
8L	264	244
9L	292	272
10L	320	300

For options, see p.170.

Dimensions of Manifold (mm)

For 5-port

BM□A

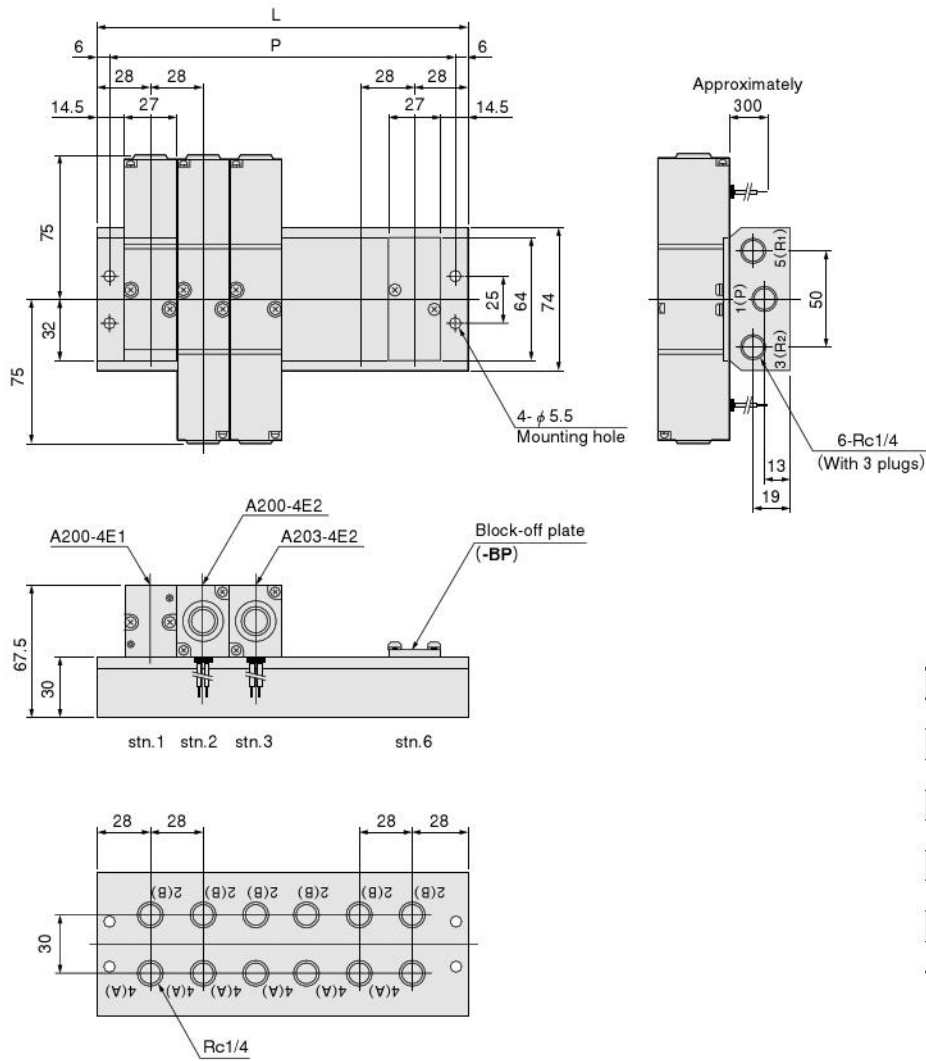

Unit dimensions

Model	L	P
BM2A	84	72
3A	112	100
4A	140	128
5A	168	156
6A	196	184
7A	224	212
8A	252	240
9A	280	268
10A	308	296

For options, see p.170.

Dimensions of Options (mm)

For single unit

- Mounting base: -21

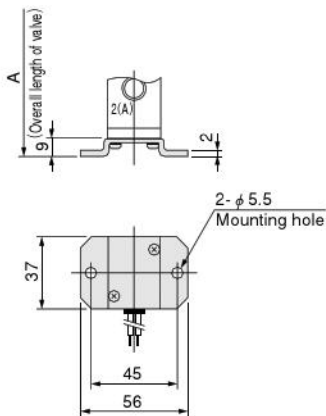

Model	Code	A
200E1		108
200-4E1		116

For single unit and manifold

- Solenoid with DIN connector: -39

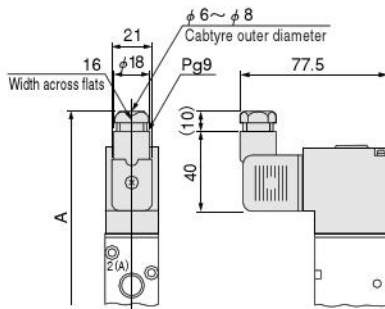

- Solenoid with LED indicator: -L

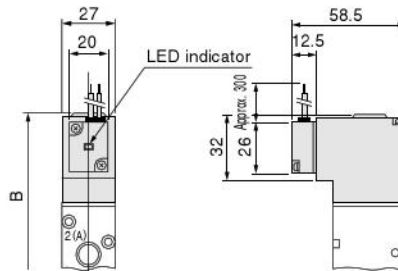

- Speed controller: -70

Note: Not available in 2-, 3-port

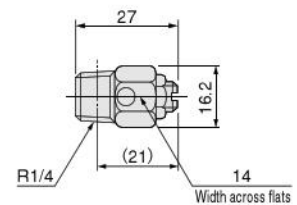

Model	Code	A	B	Remark
200E1		117	99	Overall length of valve
200-4E1		125	107	
200-4E2		186	150	
203-4E2				

For manifold

- Sub-base regulator: -52

- 54

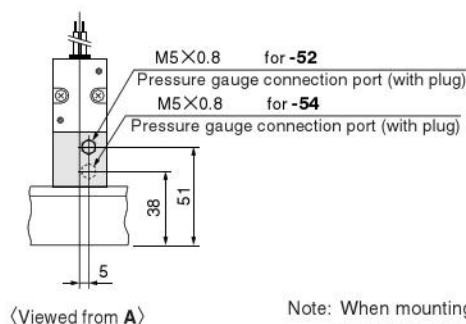
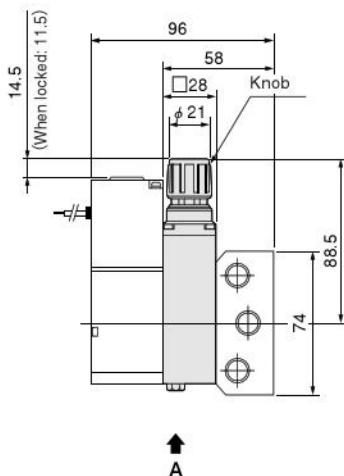

Note: When mounting the sub-base regulator, the solenoid valve lead wire direction is reversed (solenoid rotated). For details, see p.171.

Handling Instructions and Precautions



Solenoid

Internal circuit

●DC24V

Standard solenoid



Solenoid with LED indicator

Order code: -L

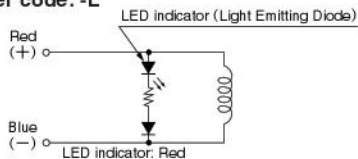

Solenoid (Surge suppression)

Order code: -SR

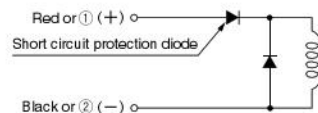

① and ② are for with DIN connector (order code: -39).

Solenoid with LED indicator (Surge suppression)

Order code: -L-SR

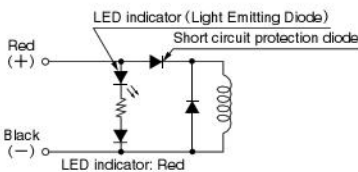

●AC100V, AC200V (Surge suppression)

Standard solenoid

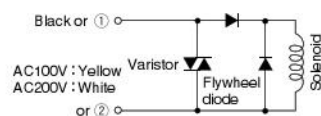

① and ② are for with DIN connector (order code: -39).

Solenoid with LED indicator

Order code: -L

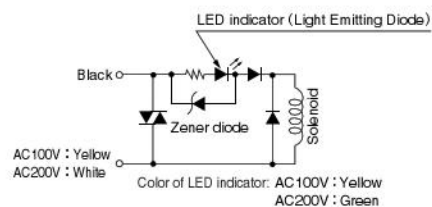

- Cautions:**
1. Do not apply megger between the lead wires.
 2. The DC solenoid will not short circuit even if the wrong polarity is applied, but the valve will not operate.
 3. Leakage current inside the circuit could result in failure of the solenoid valve to return, or in other erratic operation. Always use it within the range of the allowable leakage current. If circuit conditions, etc. cause the leakage current to exceed the maximum allowable leakage current, consult us.
 4. For a double solenoid valve, avoid

energizing both solenoids simultaneously. The valve could fall into the neutral position.

5. Since the AC solenoid uses diodes for the solenoid, always use lead wires of the same color when connecting a number of solenoid units in parallel. The DC24V standard solenoid, however, has no polarity, so either lead wire connection is acceptable.

Changing lead wire direction

The lead wire direction can be changed in the case of the add-on mounting of a sub-base regulator, etc.

Remove the two solenoid mounting screws, and rotate the solenoid 180 degrees to change the lead wire direction.

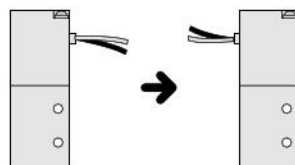

Manual override

Non-locking type

To operate the manual override, press it all the way down. The single solenoid valve works the same as when in the energized state as long as the manual override is pushed down, and returns to the rest position upon release.

For the double solenoid valve, pressing the manual override on the 12(S1) side switches the 12(S1) to the energized state, and the unit remains in that state even after the manual override is released. To return it to the rest position, operate the manual override on the 14(S2) side. This is the same for the solenoid 14(S2).

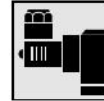
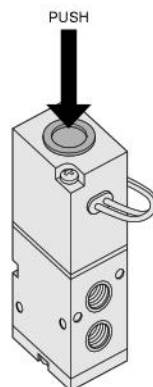

DIN connector

Wiring instructions

Remove the cover mounting screws, and lift the terminal cover off from the solenoid. Use a screwdriver (blade width 4~4.5mm [0.16~0.18in.]), etc. to push strongly against the terminal body through the hole of the terminal cover's mounting screw, and remove the terminal body.

Slip a cable gland, washer, and cable gasket over a cable (outer diameter 6~8mm [0.24~0.31in.]), insert the cable into the terminal cover's wiring port, and connect the lead wire to the terminal body (screwdriver blade width of about 3mm [0.12in.]).

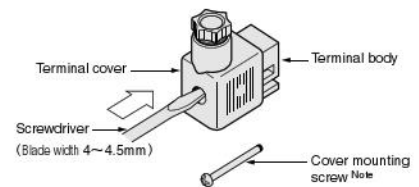

Note: The appropriate tightening torque for the cover mounting screw is 29.4N·cm (3kgf·cm) [2.6in·lbf].

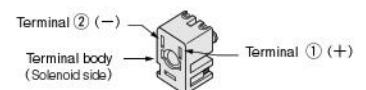
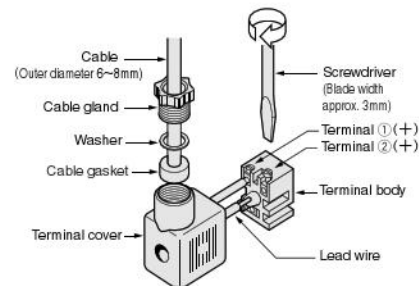

※For the DC24V solenoid with surge suppression, connect (+) to Terminal ①, and (-) to Terminal ②.



Sub-base regulator

Application example

● 1(P) port pressure regulating type

Order code: -52

The 4(A) and 2(B) ports are regulated to the same pressure.

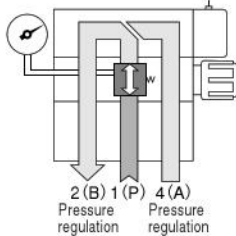

● 2(B) port pressure regulating type

Order code: -54

Regulates 2(B) port pressure

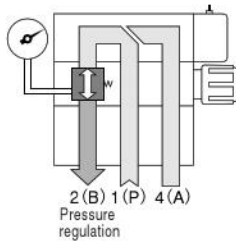

● 2(B) port pressure regulating type

Order code: -54

While using the 2(B) port pressure regulating type to regulate 4(A) port pressure

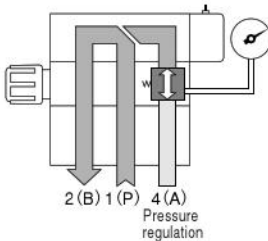

When the 2(B) port pressure regulating type (order code: -54) is used to regulate 4(A) port pressure, mount the sub-base regulator so that the knob is on the 3(R2) port side of the manifold.

Pressure regulation

1. Connect a pressure gauge to check the pressure setting. A compact pressure gauge (Model G1-20) is recommended.
2. To regulate the pressure, pull the knob out firmly, and turn it to the right (clockwise rotation) to increase the pressure, and to the left (counterclockwise rotation) to reduce the pressure. After pressure regulation, push the knob back into the body and lock in place.

Mounting

The sub-base regulator is mounted between the manifold and the valve. While the sub-base regulator's knob is on the 5(R1) port side of the manifold for the standard type, the knob for the 2(B) port pressure regulating type is mounted so that the handle comes to the 3(R2) port side of the manifold, and can also regulate the pressure of the 4(A) port. For mounting directions and functions, see the Application example.

Cautions: 1. Pay attention to the sub-base regulator facing and the front/back sides when newly mounting a sub-base regulator, or when changing the pressure regulating port. In the 1(P) port pressure regulating type: -52, the knob is on the 5(R1) side, and the pressure gauge connection port is on the valve side. In the 2(B) port pressure regulating type: -54, the knob is on the 5(R1) side for 2(B) port pressure regulation, and on the 3(R2) side for 4(A) port pressure regulation. In both cases, the pressure gauge connection port is on the manifold side.

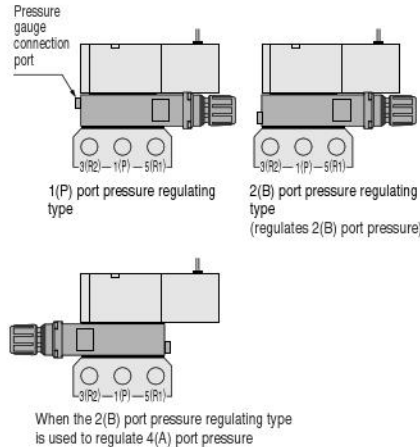

2. When the solenoid is a grommet type, change the solenoid orientation after confirming the "Changing lead wire direction" on the previous page, to prevent interference between the lead wires and the sub-base regulator.